



POLES

TABLE OF CONTENTS

02 00 00 01
1 of 1

WOOD POLE DATA.....	02 00 01 01
POLE NUMBERING - 35kV, 69kV.....	02 00 01 02
MAXIMUM EQUIPMENT WEIGHTS.....	02 00 02 00
STANDARD EQUIPMENT POLE SIZES & CLASSES.....	02 00 02 01
COMPOSITE POLE DATA.....	02 00 04 01
UNGUYED COMPOSITE POLE.....	02 00 04 02
POLE INSTALLATION - SETTING DEPTHS.....	02 20 03 01
BACKFILL AND REINFORCEMENT.....	02 20 05 **
STORM HARDENING STRUCTURE.....	02 30 10 01
COMPOSITE SWITCH POLES - STOCK CODES.....	02 30 10 02
POLE STEPS.....	02 40 32 **
VISIBILITY MARKERS.....	02 40 43 00
POLE EXTENSION FOR CROSSARM.....	02 40 46 **
OBSTRUCTION LIGHT.....	02 40 48 00
POLE TOP PROTECTION.....	02 40 49 00



POLES

Wood Pole Data

02 00 01 01

1 of 3

This standard covers stock codes, weights, and loading criteria for wood poles, in particular Southern Yellow Pine (SYP) and Douglas Fir (DF). Those are the standard pole species for the Ameren Distribution System.

The weight and circumference in these tables are approximate and should be used as a guide for shipping and handling purposes. Poles are a natural resource and may vary in weight and size within their respective class.

Wood poles, wood cross-arms, and empty non-returnable wood reels removed from the Ameren System shall, whenever possible, be disposed of on the job or taken back to the Operating Center for disposal. However, Ameren or contractor crews may provide these to a land owner upon such landowner's request. In doing so, all Construction crews shall abide by Ameren's Corporate Procedure "Investment Recovery and Accommodation Sale Policy". As required in the procedure, the recipient(s) receiving wood poles or cross-arms are required to sign Form 5809NS. Construction crews may not provide landowner materials until Form 5809NS is approved by Ameren Supervision.

Wood pole sizes have been standardized. The sizes in the table are the only available sizes for their respective heights.

Table 1 - SYP Stock Codes						
Height	Class					
	1	3	5	H1	H2	H4
30'	41 02 301	41 02 303	41 02 305	-	-	-
35'	41 02 351	41 02 353	41 02 355	-	-	-
40'	41 02 401	41 02 403	-	-	-	-
45'	41 02 451	41 02 453	-	-	41 02 245	45 02 445
50'	41 02 501	-	-	-	41 02 250	-
55'	41 02 551	-	-	41 02 155	41 02 953	41 02 855
60'	41 02 601	-	-	41 02 160	41 02 954	41 02 460
65'	41 02 651	-	-	41 02 165	41 02 988	41 02 465
70'	41 02 701	-	-	-	41 02 270	41 02 470
75'	41 02 751	-	-	-	41 02 275	41 02 475
80'	41 02 801	-	-	41 02 180	41 02 280	41 02 480
85'	41 02 851	-	-	41 02 185	41 02 285	-
90'	41 02 901	-	-	-	-	-

Table 2 - DF Stock Codes							
Height	Class						
	1	H1	H2	H3	H4	H5	H6
50'	41 42 001	-	41 42 194	41 42 195	41 42 196	-	-
55'	41 42 002	41 42 197	41 42 198	41 42 199	41 42 200	-	-
60'	41 42 003	41 42 193	41 42 201	41 42 202	41 42 203	41 42 204	-
65'	41 42 004	41 42 077	41 42 205	41 42 206	41 42 207	41 42 208	-
70'	41 42 005	41 42 085	41 42 209	41 42 210	41 42 184	41 42 211	41 42 187
75'	41 42 049	41 42 078	41 42 101	41 42 212	41 42 213	41 42 214	41 42 215
80'	41 42 062	41 42 079	41 42 094	41 42 216	41 42 185	41 42 217	41 42 188
85'	41 42 063	41 42 075	41 42 090	41 42 218	41 42 219	41 42 220	41 42 221
90'	41 42 058	41 42 076	41 42 095	41 42 222	41 42 223	41 42 224	41 42 183
95'	41 42 035	41 42 084	41 42 097	41 42 225	41 42 186	41 42 226	41 42 189
100'	41 42 032	41 42 081	41 42 098	41 42 227	41 42 228	41 42 229	41 42 190
105'	41 42 067	41 42 096	41 42 091	41 42 230	41 42 231	41 42 232	41 42 233
110'	41 42 080	41 42 089	41 42 099	41 42 234	41 42 235	41 42 236	41 42 191
115'	41 42 086	41 42 088	41 42 100	41 42 237	41 42 238	41 42 239	41 42 240
120'	41 42 074	41 42 092	41 42 093	41 42 241	41 42 242	41 42 243	41 42 192
125'	-	-	41 42 244	-	-	-	-

DISTRIBUTION CONSTRUCTION STANDARDS

REV	DATE	ENG	DESCRIPTION
8	10/01/20	KR	Title change; STK #s added; Modified disposal note; Comb. W/ 02 00 03 01
7	02/15/12	MJ	



POLES
Wood Pole Data

02 00 01 01

2 of 3

Table 3 - Loading, Diameters and Weight

Wood Pole		Southern Yellow Pine & Douglas Fir					
Class		5	3	1	H1	H2	
Min. Top Circ. Ct(in)		19	23	27	29	31	
Horiz. Load (lbs) \diamond 2		1,900	3,000	4,500	5,400	6,400	
Pole Height (Ft)	Class	SYP			DF		
		Min. Circ. (in)		Average Weight (lbs)	Min. Circ. (in)		Average Weight (lbs)
		Ground Line-Cg	6' from butt- Cg		Ground Line-Cg	6' from butt- Cg	
30	1	36.9	36.5	1,020	36.9	36.5	1,062
	3	32.4	32.0	770	32.4	32.0	851
	5	27.9	27.5	580	27.9	27.5	563
35	1	39.2	39.0	1,310	39.2	39.0	1,292
	3	34.2	34.0	985	34.2	34.0	1,040
	5	29.2	29.0	740	29.2	29.0	698
40	1	41.0	41.0	1,630	41.0	41.0	1,598
	3	36.0	36.0	1,225	36.0	36.0	1,242
45	1	42.8	43.0	1,965	42.8	43.0	1,940
	3	37.3	37.5	1,475	37.3	37.5	1,526
50	H2	-	-	-	-	-	-
	H1	-	-	-	-	-	-
	1	44.6	45.0	2,330	44.6	45.0	2,237
55	H2	-	-	-	-	52.0	3,294
	H1	-	-	-	-	49.5	2,808
	1	45.9	46.5	2,715	45.9	46.5	2,552
60	H2	-	-	-	52.5	54.0	3,852
	H1	-	-	-	49.6	51.0	3,380
	1	47.2	48.0	3,130	47.2	48.0	2,885
65	H2	-	-	-	51.0	55.5	4,320
	H1	-	-	-	47.8	52.5	3,821
	1	48.5	49.5	3,555	48.5	49.5	3,240
70	H2	-	-	-	55.2	57.0	4,815
	H1	-	-	-	52.2	54.0	4,289
	1	49.9	51.0	4,005	49.9	51.0	3,492
75	H2	-	-	-	57.6	59.0	5,297
	H1	-	-	-	53.6	55.5	4,694
	1	51.2	52.5	4,475	51.2	52.5	4,005

**DISTRIBUTION
CONSTRUCTION STANDARDS**

REV	DATE	ENG	DESCRIPTION
8	10/01/20	KR	Title change; STK #s added; Modified disposal note; Comb. W/ 02 00 03 01
7	02/15/12	MJ	



POLES
Wood Pole Data

02 00 01 01

3 of 3

Table 3 - Continued

Wood Pole		Southern Yellow Pine & Douglas Fir					
Class		5	3	1	H1	H2	
Min. Top Circ. Ct(in)		19	23	27	29	31	
Horiz. Load (lbs) \diamond 2		1,900	3,000	4,500	5,400	6,400	
Pole Height (Ft)	Class	SYP			DF		
		Min. Circ. (in)		Average Weight (lbs)	Min. Circ. (in)		Average Weight (lbs)
		Ground Line-Cg	6' from butt- Cg		Ground Line-Cg	6' from butt- Cg	
80	H2	-	-	-	57.8	60.0	5,841
	H1	-	-	-	53.6	57.0	5,184
	1	52.5	54.0	4,965	52.5	54.0	4,419
85	H2	-	-	-	61.5	61.5	6,413
	H1	-	-	-	56.8	58.5	5,702
	1	53.4	55.0	5,480	53.4	55.0	5,013
90	H2	-	-	-	59.2	63.0	7,011
	H1	-	-	-	56.3	59.5	6,242
	1	54.3	56.0	6,005	54.3	56.0	5,310
95	H2	-	-	-	60.5	64.5	7,628
	H1	-	-	-	57.1	61.0	6,818
	1	55.1	57.0	6,550	55.1	57.0	5,427
100	H2	-	-	-	62.7	65.5	8,240
	H1	-	-	-	59.4	62.0	7,362
	1	56.5	58.5	7,115	56.5	58.5	6,282

DESIGN NOTE(s):

1. Alternatives such as laminated wood, steel, and composite poles are available for special applications.
- \diamond 2. Minimum ultimate single point load (lbs) 2 feet from top of pole per ANSI C05.1.

REV	DATE	ENG	DESCRIPTION
8	10/01/20	KR	Title change; STK #s added; Modified disposal note; Comb. W/ 02 00 03 01
7	02/15/12	MJ	



POLES
Pole Numbering

INSTRUCTIONS - INSTALLATION

ILLINOIS ONLY

- Sub Transmission - All sub transmission lines shall be numbered at each 1st structure coming out of the substation with the circuit number at the top of the pole, on both sides. The 5th structure shall be numbered with #5, then each 5th structure will be numbered in sequence starting at the normal source end of the line. Poles shall be numbered on both sides at major road crossings.

In the event a new pole or poles are added between any of the aerial patrol (AP) numbers (Example between 301 and 302) add pole number designation 301A, 301B, 301C, etc.

- Aerial Patrol Numbering - All sub transmission lines numbered for aerial patrolling shall be numbered in consecutive sequence on both sides of each structure that has a number divisible evenly by 5.

When sub transmission poles are either repaired or replaced a new AP number should be installed if the sequence is as mentioned in the above paragraph. If an AP number already exists on the pole, front and back side, no action would be required.

When a structure that should be numbered is located at a major angle in the line and cannot be numbered, either of the adjacent structures shall be numbered with its own structure number. Example, if the major angle is on pole 95, the structure in front would be 94 and the structure behind would be 96; keeping in consecutive order with the other numbered poles.

Numbering shall be continuous from one major switching station to another.

Tap lines shall be numbered with number 1 on the first structure from the junction with the main line.

Aerial patrol numbers shall be located on structures as indicated by drawings in this standard. Typically numbers shall be installed below the first set of insulators (between 1st and 2nd set), if the pole is unshielded. If the pole is shielded, then the numbers can be installed at top of the pole below the shield wire.

- Wood poles - The vertical holder shall be installed using two lag screws, 2" long with 1/4" diameter (Stock #23 60 033). An alternative to the vertical holder for a wood pole is to securely nail the plates directly to the pole (four holes in each plate).
- Composite Poles / Fiberglass Poles - Use #10 hex head 3/4" long self-tapping screws (Stock #21 76 679) in predrilled holes. If pole is not predrilled, use drill bit (Stock #86 04 289) to drill pilot hole. This length will work on all composite poles.
- Tag Holder and Inserts
Material used in numbering sub transmission lines shall be Black on Yellow, Aluminum 5"W x 7"H w/6" Number Embossed with a Vertical Aluminum Number Plate 29"H x 5 1/4"W. Tags will be produced from following stock numbers.

Stock Number	Description
16 04 627	Numeral "0"
16 04 628	Numeral "1"
16 04 629	Numeral "2"
16 04 630	Numeral "3"
16 04 631	Numeral "4"
16 04 632	Numeral "5"
16 04 633	Numeral "6" or "9"
16 04 634	Numeral "7"
16 04 635	Numeral "8"
16 02 691	Letter "A"
16 02 689	Letter "B"
16 02 690	Letter "C"
16 06 272	Tag Holder - Vertical

REV	DATE	ENG	DESCRIPTION
1	04/01/22	KR	Old 29 00 19 01; revised & updated entire standard
0	07/23/15	JLH	First Issue

ILLINOIS ONLY

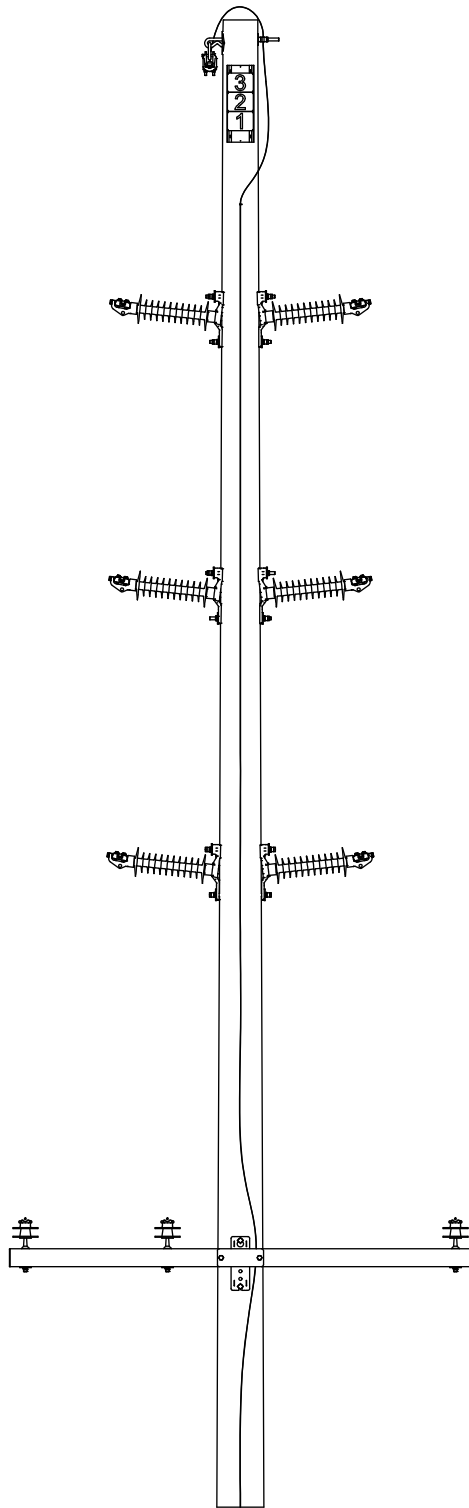

SHIELDED

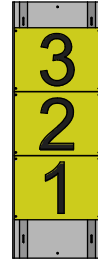

DETAIL A

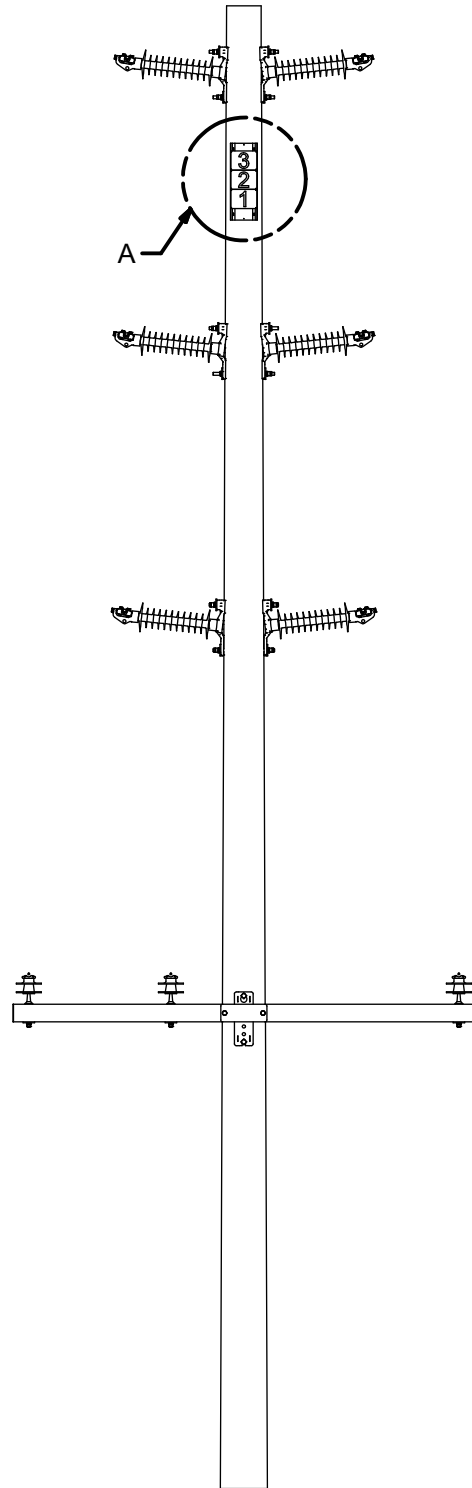

UNSHIELDED

REV	DATE	ENG	DESCRIPTION
1	04/01/22	KR	Old 29 00 19 01; revised & updated entire standard
0	07/23/15	JLH	First Issue

This Standard covers maximum equipment weights for wood poles that are excluded from DCS 02 00 02 01. The values listed in table below are for restrained poles only. **For unrestrained poles divide the listed values by 4.** It will not always be possible to utilize the maximum weights due to other restricting factors. Restricting factors, which can limit the load are the length and rating of gin poles, reef of blocks, load capacity of blocks, existing obstructions and clearances due to circuit configurations. All factors should be considered when determining the equipment weights, which can be installed on a wood pole.

Restrained Pole

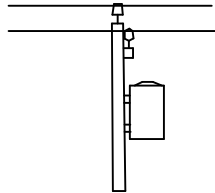

THROUGH PRIMARY - LOAD
ON FACE OR BACK OF POLE

Unrestrained Pole

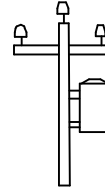

THROUGH PRIMARY - LOAD
ON FACE OR BACK OF POLE.
NO GUY

From Top (ft)	Maximum Equipment Weight (lbs.) on Restrained Pole		
	Class 5	Class 3	Class 1
30 & 35 Feet			
5	1,371	3,124	-
7	1,573	3,586	-
9	1,825	4,159	-
11	2,141	4,881	-
40 & 45 Feet			
5	-	2,670	4,794
7	-	2,959	5,312
9	-	3,296	5,919
11	-	3,696	6,636
13	-	4,172	7,491
50 & 55 Feet			
5	-	-	4,251
7	-	-	4,613
9	-	-	5,022
11	-	-	5,489
13	-	-	6,025
15	-	-	6,542

REV	DATE	ENG	DESCRIPTION
6	10/01/20	KR	Converted to new format
5	01/01/20	KR	



POLES

Standard Equipment Pole Sizes & Classes

02 00 02 01

1 of 2

Application	Exist Pole		New Pole					
	Ht.	WP Cl.	Ht.	WP Cl.	CP Dia. ◊ 2			
1. Service poles and extensions on private property	30'	6	35'	3	12"			
2. Single Phase Circuit:								
a. Joint Use Construction	35'	6	35'	3	12"			
b. Non-Joint Use Construction	35'	6	35'	3	12"			
3. Three Phase Circuit:								
a. Joint Use Construction	45'	6	45'	3	12"			
b. Non-Joint Use Construction	40'	6	40'	3	12"			
4. 16 kV Full Arm Terminal Pole ◊ 2	-	5	-	3	14"			
4. 16 kV Side Arm Terminal Pole ◊ 2	-	4	-	3	14"			
13.8 kV Terminal Pole ◊ 2	-	4	-	3	14"			
34.5 kV Terminal Pole	-	3	-	1	12"/14"			
13.2 kV Pole Top Switch	-	3	-	1	-			
34.5 kV Pole Top Switch	-	-	-	H2	-			
34.5 kV Group Operated Switch ◊ 2 ◊ 3	-	-	-	H2	12"/14"			
69 kV Group Operated Switch ◊ 2	-	-	-	-	12"/14"			
T - L Pole or Cross-Corner Poles (Guying may be necessary)	One Class higher than the line poles.							
Side Arm Poles								
Transformer								
Single		Two	Three					
1-Phase	3-Phase							
> 25 kVA	-	-	-	-	7	-	3	12"
25 kVA	30 kVA	1-25 & 1-10 kVA	3-15 kVA	-	5	-	3	12"
50 kVA	45kVA	1-50 & 1-25 kVA	-	-	5	-	3	14"
75 kVA	75 kVA	-	-	-	5	-	3	14"
100 kVA	112 kVA	1-100 & 1-50 kVA	3-25 kVA	-	5	-	1	14"
167 kVA	150 kVA	1-167 & 1-50 kVA	3-50 kVA	-	3	-	1	14"
250 kVA	225 kVA		3-100 kVA	-	2	-	1	14"
	300 kVA		3-167 kVA	-	2	-	1	14"
	500 kVA		3-250 kVA	-	1	-	H1	14"
			3-333 kVA	-	H1	-	H2	12"/14"

DISTRIBUTION CONSTRUCTION STANDARDS

REV	DATE	ENG	DESCRIPTION
5	10/01/20	KR	Added Note 4; converted to new format
4	01/01/20	KR	



POLES

Standard Equipment Pole Sizes & Classes

02 00 02 01

2 of 2

Application						Exist. Pole	New Pole	
						Class	WP Class	CP Dia. ⬡ 2
Two Pole Transformer Platform						3	1	14"
Center Support Pole for Platform Poles						3	1	14"
50 to 300 kVAR Capacitor Bank, 15 kV						5	1	14"
300 to 1200 kVAR Capacitor Bank, 15 kV						4	1	14"
Circuit Reclosers								
34 kV Electronic Recloser						-	H2	12"/14"
12 kV Single Phase Electronic Recloser						5	3	14"
12 kV Three Phase Electronic Recloser						5	1	14"
Voltage Regulators								
Single Phase			Two Or Three Phase					
kVa	Nameplate Amperes		kVa					
	2500 V	7620 V		2500 V	7620 V			
50	200	-	-	-	-	5	1	14"
76.2	-	100	-	-	-	4	1	14"
100	400	-	-	-	-	2	1	12"/14"
114.3	-	150	-	-	-	2	1	12"/14"
167	668	219	50	200	-	1	H2	12"/14"
250	-	328	76.2	-	100	1	H2	12"/14"
333	-	438	3-100	400	-	H1	H2	12"/14"
			3-167	-	219	H1	H2	12"/14"
			250 ⬡ 1	-	328	-	H2	12"/14"
			333 ⬡ 1	-	438	-	H2	12"/14"
Two Pole Platform						-	-	-
			250	-	328	-	H2	12"/14"
			333	-	428	-	H2	12"/14"

DESIGN NOTE(s):

- ⬡1. Consider using composite poles on any application candidate for replacement due to wood pole deflection caused by equipment weight.
- ⬡2. Composite poles listed are the minimum required sizes. For longer and larger poles, contact Standards. Steel and laminated wood poles are also available for these applications.
- ⬡3. For 34.5V group operated switches H2 wood poles are available for Missouri only.
- ⬡4. The height and class of poles are determined by the number of conductors, the weight to be suspended, and ground clearance obstructions.

REV	DATE	ENG	DESCRIPTION
5	10/01/20	KR	Added Note 4; converted to new format
4	01/01/20	KR	



POLES

Composite Pole Data

02 00 04 01

1 of 2

This standard covers composite pole stock codes and weights used in Ameren Distribution and Sub-transmission system.

Table 1		Single Layer Composite Poles						
Height (Ft.)	12" Diameter		14" Diameter		15" Diameter		17" Diameter	
	Stock Code	Weight (lbs.)	Stock Code	Weight (lbs.)	Stock Code	Weight (lbs.)	Stock Code	Weight (lbs.)
35'	41 35 012	542	41 35 014	917	41 35 015	1015	41 35 017	1253
40'	41 40 012	619	41 40 014	1048	41 40 015	1160	41 40 017	1432
45'	41 45 012	697	41 45 014	1179	41 45 015	1305	41 45 017	1611
50'	41 50 012	774	41 50 014	1310	41 50 015	1450	41 50 017	1790
55'	41 55 012	851	41 55 014	1441	41 55 015	1595	41 55 017	1969
60'	-	-	41 60 014	1572	41 60 015	1740	41 60 017	2148
65'	-	-	41 65 014	1703	41 65 015	1885	41 65 017	2327
70'	-	-	41 70 014	1834	41 70 015	2030	41 70 017	2506
75'	-	-	41 75 014	1965	41 75 015	2175	41 75 017	2685
80'	-	-	-	-	41 80 015	2320	41 80 017	2864
85'	-	-	-	-	41 85 015	2465	41 85 017	3043
90'	-	-	-	-	-	-	41 90 017	3222
95'	-	-	-	-	-	-	41 95 017	3401

Table 2		Dual Layer Composite Poles				
Height (Ft.)	12"/14" Diameter		14"/15" Diameter		15"/17" Diameter	
	35' to 55' = 10ft. Separation 60' to 75' = 15ft. Separation		35' to 55' = 10ft. Separation 60' to 85' = 15ft. Separation		35' to 55' = 10ft. Separation 60' to 95' = 15ft. Separation	
	Stock Code	Weight (lbs.)	Stock Code	Weight (lbs.)	Stock Code	Weight (lbs.)
35'	41 35 826	1197	41 35 829	1642	41 35 832	1910
40'	41 40 826	1405	41 40 829	1918	41 40 832	2234
45'	41 45 826	1614	41 45 829	2194	41 45 832	2558
50'	41 50 826	1822	41 50 829	2470	41 50 832	2882
55'	41 55 826	2030	41 55 829	2746	41 55 832	3206
60'	41 60 826	2108	41 60 829	2877	41 60 832	3351
65'	41 65 826	2316	41 65 829	3153	41 65 832	3675
70'	41 70 826	2525	41 70 829	3429	41 70 832	3999
75'	41 75 826	2733	41 75 829	3705	41 75 832	4323
80'	-	-	41 80 829	3981	41 80 832	4647
85'	-	-	41 85 829	4257	41 85 832	4971
90'	-	-	-	-	41 90 832	5295
95'	-	-	-	-	41 95 832	5619

REV	DATE	ENG	DESCRIPTION
3	10/01/20	KR	Updated all available Composite Pole sizes & stk #s & Notes
2	07/04/15	MJ	



POLES
Composite Pole Data

Table 3		Multi Layer Composite Poles				
Height (Ft.)	12"/14"/15" Diameter		14"/15"/17" Diameter		12"/14"/15"/17" Diameter	
	50' to 55' = 10ft. Separation 60' to 100' = 15ft. Separation		50' to 55' = 10ft. Separation 60' to 110' = 15ft. Separation		50' to 70' = 10ft. Separation 60' to 110' = 15ft. Separation	
	Stock Code	Weight (lbs.)	Stock Code	Weight (lbs.)	Stock Code	Weight (lbs.)
50'	41 50 841	2692	41 50 846	3544	41 50 858	3408
55'	41 55 841	3045	41 55 846	3999	41 55 858	3940
60'	41 60 841	2978	41 60 846	3951	41 60 858	3515
65'	41 65 841	3331	41 65 846	4406	41 65 858	4047
70'	41 70 841	3685	41 70 846	4861	41 70 858	4580
75'	41 75 841	4038	41 75 846	5316	41 75 858	5112
80'	41 80 841	4391	41 80 846	5771	41 80 858	5644
85'	41 85 841	4745	41 85 846	6226	41 85 858	6177
90'	41 90 841	5098	41 90 846	6681	41 90 858	6709
95'	41 95 841	5452	41 95 846	7136	41 95 858	7242
100'	41 10 841	5805	41 10 846	7591	41 10 858	7774
105'	-	-	41 05 846	8046	41 05 858	8306
110'	-	-	41 01 846	8501	41 01 858	8839

DESIGN NOTE(s):

1. The composite poles in these charts are pre-drilled in the factory during fabrication. The poles are drilled to common standard configurations with an internal ground wire. Non-standard applications shall be communicated with the manufacturer for hole drilling locations.

2. 10' separation throughout pole will be an additional stock number. Contact Standards for those numbers. This would need to be applied in limited circumstances to help reduce deflection for larger structures.

REV	DATE	ENG	DESCRIPTION
3	10/01/20	KR	Updated all available Composite Pole sizes & stk #s & Notes
2	07/04/15	MJ	



POLES

Unguyed Composite Pole

02 00 04 02

1 of 3

This standard covers unguyed composite pole installations with standard configurations. The correct stock number for composite poles is determined by the number of wires, wire weight and tension, line angle, and NESC Grade B safety loading requirements. The tables apply to common applications in good soil without detailed calculations. Other unguyed or partially guyed pole applications will require communication with Standards.

Table 1		150' Ruling Span under NESC Heavy Loading				
1-1/0 AAAC Conductor (Tension = 1,200 lbs./ cond.) & 1-1/0 AAAC Neutral (Tension = 1,200 lbs./ cond.)						
Description	Line Angle					
	Tangent	Fixed		Floating		Deadend Corner
	≤1°	>1° & ≤10°	>10° & ≤20°	>20° & ≤40°	>40° & ≤60°	>60° & ≤90°
Span Length ≥125' & <175'						
Pole Diameter (in)	12	12	12	12	14	14
Pole Height (ft)	40	40	40	40	40	45
Stock #	41 40 012	41 40 012	41 40 012	41 40 012	41 40 014	41 45 014
Configuration	03 12 01 **	03 12 01 **	03 12 01 **	03 12 01 **	03 12 01 **	03 12 01 **
Auger Size (in)	24	24	24	24	24	24
Pole Depth (ft)	6	7.5	7.5	7.5	7.5	9.5
Approx. Rake (in)	0	6	12	18	12	22
Backfill Stds	02 20 05 11	02 20 05 11	02 20 05 11	02 20 05 12	02 20 05 12	02 20 05 15

Table 2		200' Ruling Span under NESC Heavy Loading				
1-1/0 AAAC Conductor (Tension = 1,400 lbs./ cond.) & 1-1/0 AAAC Neutral (Tension = 1,400 lbs./ cond.)						
Description	Line Angle					
	Tangent	Fixed		Floating		Deadend Corner
	≤1°	>1° & ≤10°	>10° & ≤20°	>20° & ≤40°	>40° & ≤60°	>60° & ≤90°
Span Length ≥175' & <225'						
Pole Diameter (in)	12	12	12	12	14	15
Pole Height (ft)	40	40	40	40	40	45
Stock #	41 40 012	41 40 012	42 40 012	43 40 012	41 40 014	41 45 015
Configuration	03 12 01 **	03 12 01 **	03 12 01 **	03 12 01 **	03 12 01 **	03 12 01 **
Auger Size (in)	24	24	24	24	24	30
Pole Depth (ft)	6	7.5	7.5	7.5	7.5	9.5
Approx. Rake (in)	0	8	12	20	14	15
Backfill Stds	02 20 05 11	02 20 05 11	02 20 05 11	02 20 05 12	02 20 05 12	02 20 05 15

Table 3		150' Ruling Span under NESC Heavy Loading				
3-556 AAC Conductor (Tension = 3,000 lbs./ cond.) & 1-1/0 AAAC Neutral (Tension = 1,200 lbs./ cond.) & Comm.						
Description	Line Angle					
	Tangent	Fixed		Floating		Deadend Corner
	≤1°	>1° & ≤10°	>10° & ≤20°	>20° & ≤40°	>40° & ≤60°	>60° & ≤90°
Span Length ≥125' & <175'						
Pole Diameter (in)	11	12	14	14/15	14/15	15/17
Pole Height (ft)	45	45	45	55	55	55
Stock #	41 45 012	41 45 012	41 45 014	41 55 829	41 55 829	41 55 832
Configuration	03 12 06 **	03 12 06 **	03 12 06 **	03 12 07 **	03 12 07 **	03 12 09 **
Auger Size (in)	24	24	30	30	30	30
Pole Depth (ft)	6	8	8	10.5	10.5	12
Approx. Rake (in)	0	14	26	16	24	20
Backfill Stds	02 20 05 11	02 20 05 12	02 20 05 12	02 20 05 12	02 20 05 15	02 20 05 15

DISTRIBUTION CONSTRUCTION STANDARDS

REV	DATE	ENG	DESCRIPTION
2	10/01/20	KR	Combined 02 00 04 02, 03, 04, & 05; added Notes 1 & 2
1	10/17/12	MJ	



POLES

Unguyed Composite Pole

02 00 04 02

2 of 3

Table 4	200' Ruling Span under NESC Heavy Loading					
3-556 AAC Conductor (Tension = 3,700 lbs./ cond.) & 1-1/0 AAAC Neutral (Tension = 1,400 lbs./ cond.) & Comm.						
Description	Line Angle					
	Tangent	Fixed		Floating		Deadend Corner
	≤1°	>1° & ≤10°	>10° & ≤20°	>20° & ≤40°	>40° & ≤60°	>60° & ≤90°
Span Length ≥175' & <225'						
Pole Diameter (in)	12	14	15	14/15	15/17	15/17
Pole Height (ft)	45	45	45	55	55	55
Stock #	41 45 012	41 45 014	41 45 015	41 55 829	41 55 832	41 55 832
Configuration	03 12 06 **	03 12 06 **	03 12 06 **	03 12 07 **	03 12 07 **	03 12 09 **
Auger Size (in)	24	24	30	30	30	30
Pole Depth (ft)	6	8	8	10.5	10.5	12
Approx. Rake (in)	0	24	22	24	20	28
Backfill Stds	02 20 05 11	02 20 05 12	02 20 05 12	02 20 05 12	02 20 05 12	02 20 05 15

Table 5	150' Ruling Span under NESC Heavy Loading					
3-954 ACSR Conductor (Tension = 3,000 lbs./ cond.) & 1-1/0 AAAC Static (Tension = 1,200 lbs./ cond.)						
Description	Line Angle					
	Tangent	Fixed		Floating		Deadend Corner
	≤1°	>1° & ≤10°	>10° & ≤20°	>20° & ≤40°	>40° & ≤60°	>60° & ≤90°
Span Length ≥125' & <175'						
Pole Diameter (in.)	14	12/14	12/14	14/15	15/17	14/15/17
Pole Height (ft)	60	60	60	60	60	65
Stock #	41 60 014	41 60 826	41 60 826	41 60 829	41 60 832	41 65 846
Configuration	03 69 51 01	03 69 52 02	03 69 52 03	03 69 10 01	03 69 10 01	03 69 15 01
Auger Size (in)	24	24	30	30	30	30
Pole Depth (ft)	8	9.5	9.5	11	11	13
Approx. Rake (in)	0	12	22	22	22	18
Backfill Stds	02 20 05 11	02 20 05 11	02 20 05 12	02 20 05 12	02 20 05 12	02 20 05 15

Table 6	200' Ruling Span under NESC Heavy Loading					
3-954 ACSR Conductor (Tension = 4,000 lbs./ cond.) & 1-1/0 AAAC Neutral (Tension = 1,400 lbs./ cond.)						
Description	Line Angle					
	Tangent	Fixed		Floating		Deadend Corner
	≤1°	>1° & ≤10°	>10° & ≤20°	>20° & ≤40°	>40° & ≤60°	>60° & ≤90°
Span Length ≥175' & <225'						
Pole Diameter (in.)	14	12/14	14/15	15/17	15/17	14/15/17
Pole Height (ft)	60	60	60	60	60	65
Stock #	41 60 014	41 60 826	41 60 829	41 60 832	41 60 832	41 65 846
Configuration	03 69 51 01	03 69 52 02	03 69 52 03	03 69 10 01	03 69 10 01	03 69 15 01
Auger Size (in)	24	24	30	30	30	30
Pole Depth (ft)	8	9.5	9.5	11	11	13
Approx. Rake (in)	0	16	16	20	28	22
Backfill Stds	02 20 05 11	02 20 05 11	02 20 05 12	02 20 05 12	02 20 05 12	02 20 05 15

REV	DATE	ENG	DESCRIPTION
2	10/01/20	KR	Combined 02 00 04 02, 03, 04, & 05; added Notes 1 & 2
1	10/17/12	MJ	



POLES

Unguyed Composite Pole

02 00 04 02

3 of 3

Table 7	150' Ruling Span under NESC Heavy Loading					
3-954 ACSR Conductor (Tension = 3,000 lbs./ cond.) & 1-1/0 AAAC Static (Tension = 1,200 lbs./ cond.) 3-556 AAC Conductor (Tension = 3,100 lbs./ cond.) & 1-1/0 AAAC Neutral (Tension = 1,200 lbs./ cond.)						
Description	Line Angle					
	Tangent $\diamond 2$	Fixed		Floating		Deadend Corner
	$\leq 1^\circ$	$>1^\circ$ & $\leq 10^\circ$	$>10^\circ$ & $\leq 20^\circ$	$>20^\circ$ & $\leq 40^\circ$	$>40^\circ$ & $\leq 60^\circ$	$>60^\circ$ & $\leq 90^\circ$
Span Length $\geq 125'$ & $< 175'$						
Pole Diameter (in.)	14	14/15	15/17	14/15/17	$\diamond 1$	12/14/15/17
Pole Height (ft)	70	70	70	80	$\diamond 1$	75
Stock #	41 70 014	41 70 829	41 70 832	41 80 846	$\diamond 1$	41 75 858
Configuration Stds	03 69 51 01 03 12 05 **	03 69 52 02 03 12 05 **	03 69 52 03 03 12 06 **	03 69 10 01 03 12 06 **	$\diamond 1$	03 69 15 01 03 12 09 **
Auger Size (in)	24	30	30	30	$\diamond 1$	30
Pole Depth (ft)	9	9	10.5	10.5	$\diamond 1$	14
Approx. Rake (in)	0	20	24	30	$\diamond 1$	30
Backfill Stds	02 20 05 11	02 20 05 12	02 20 05 12	02 20 05 12	$\diamond 1$	02 20 05 15

Table 8	200' Ruling Span under NESC Heavy Loading					
3-954 ACSR Conductor (Tension = 4,000 lbs./ cond.) & 1-1/0 AAAC Static (Tension = 1,400 lbs./ cond.) 3-556 AAC Conductor (Tension = 3,700 lbs./ cond.) & 1-1/0 AAAC Neutral (Tension = 1,400 lbs./ cond.)						
Description	Line Angle					
	Tangent $\diamond 2$	Fixed		Floating		Deadend Corner
	$\leq 1^\circ$	$>1^\circ$ & $\leq 10^\circ$	$>10^\circ$ & $\leq 20^\circ$	$>20^\circ$ & $\leq 40^\circ$	$>40^\circ$ & $\leq 60^\circ$	$>60^\circ$ & $\leq 90^\circ$
Span Length $\geq 175'$ & $< 225'$						
Pole Diameter (in.)	14	12/14	12/14/15	12/14/15/17	$\diamond 1$	$\diamond 1$
Pole Height (ft)	70	70	70	80	$\diamond 1$	$\diamond 1$
Stock #	41 70 014	41 70 829	41 70 841	41 80 858	$\diamond 1$	$\diamond 1$
Configuration Stds	03 69 51 01 03 12 06 **	03 69 52 02 03 12 06 **	03 69 52 03 03 12 06 **	03 69 10 01 03 12 07 **	$\diamond 1$	$\diamond 1$
Auger Size (in)	24	30	30	30	$\diamond 1$	$\diamond 1$
Pole Depth (ft)	9	10.5	10.5	12	$\diamond 1$	$\diamond 1$
Approx. Rake (in)	0	26	24	30	$\diamond 1$	$\diamond 1$
Backfill Stds	02 20 05 11	02 20 05 12	02 20 05 12	02 20 05 12	$\diamond 1$	$\diamond 1$

DESIGN NOTE(s):

- $\diamond 1$. The loadings exceed composite pole limits. Call Standards to discuss other options.
- $\diamond 2$. If OPGW is used at least a 15" pole will need to be used in tangent application.

REV	DATE	ENG	DESCRIPTION
2	10/01/20	KR	Combined 02 00 04 02, 03, 04, & 05; added Notes 1 & 2
1	10/17/12	MJ	



POLES

Installation Setting Depths

02 20 03 01

1 of 1

INSTRUCTION(s):

The standard setting depth is 10% of the pole length plus 2 feet for class 1 and smaller poles and 10% of the pole length plus 3.5 feet for class H1 and larger. The setting depth of the pole in average and poor soil should be increased by 12 inches. Soil type shall be verified by Operating Centers.

The burial depth for composite poles changes from application to application. Composite poles are unlike a guyed wood pole due to certain forces being unaccounted for with guying. Here is a standard burial depth for composite poles and forces associated with the pole.

- 10% + 2' is used for tangent applications and Storm Structures for storm hardening
- 10% + 3.5' is used for line angles up to 20°, Switch applications, and Super Storm Structures
- 10% + 5' is used for line angles from 20° to 60°
- 10% + 6.5' is used for line angles from 60° to 90°

Additional setting depth is required in poor soil conditions. If poor or swampy soil conditions are visible then an additional 2' of burial depth will be required for embedment. Ameren does not have standards for soil conditions so this will be directly based on the Engineers judgement or best practice.

For swamp areas or poor soil conditions, utilize bearing plates at the bottom of the pole (Stock # 23 67 140).

For backfilling procedures refer to DCS 02 20 05 **.

Length of Pole (ft)	Wood Pole - Class 1 & Smaller Poles					Wood Pole - Class H1 & Larger Poles				
	Setting Depth in Feet					Setting Depth In Feet				
	In Good Soil	In Solid Rock Where Depth of Soil is to Top of Rock:				In Good Soil	In Solid Rock Where Depth of Soil is to Top of Rock:			
6 ft		4 ft	2 ft	0 ft	6 ft		4 ft	2 ft	0 ft	
30	5.0	5.0	5.0	4.5	3.5	-	-	-	-	-
35	5.5	5.5	5.5	5.0	4.0	-	-	-	-	-
40	6.0	6.0	6.0	5.0	4.0	-	-	-	-	-
45	6.5	6.5	6.5	5.5	4.5	8.0	8.0	8.0	6.5	5.5
50	7.0	7.0	7.0	5.5	4.5	8.5	8.5	8.5	7.0	5.5
55	7.5	7.5	7.5	6.0	5.0	9.0	9.0	9.0	7.5	6.0
60	8.0	8.0	8.0	6.0	5.0	9.5	9.5	9.5	7.5	6.0
65	8.5	8.5	8.5	6.5	5.5	10.0	10.0	9.5	8.0	6.5
70	9.0	9.0	8.5	6.5	6.0	10.5	10.5	10.0	8.5	7.0
75	9.5	9.5	8.5	7.0	6.0	11.0	11.0	10.0	8.5	7.0
80	10.0	10.0	9.0	7.0	6.5	11.5	11.5	10.5	9.0	7.5
85	10.5	10.5	9.0	7.5	7.0	12.0	11.5	10.5	9.0	7.5
90	11.0	11.0	9.0	7.5	7.0	12.5	12.0	10.5	9.0	7.5
95	11.5	11.0	9.0	8.0	7.0	13.0	12.5	11.0	9.5	8.0
100	12.0	11.5	9.5	8.5	7.5	13.5	12.5	11.0	9.5	8.0
105	12.5	12.0	10.0	9.5	7.5	14.0	12.5	11.0	9.5	8.0
110	13.0	12.2	10.5	10.0	8.0	14.5	12.5	11.5	10.0	8.0
115	13.5	12.0	11.0	10.0	8.5	15.0	13.0	12.0	10.5	9.0
120	14.0	12.0	11.0	10.0	9.0	15.5	13.0	12.0	0.5	9.5
$D = (L/10) + 2$ Where D = Setting Depth (ft.) in good soil and L = Pole Length (ft.)						$D = (L/10) + 3.5$ Where D = Setting Depth (ft.) in good soil and L = Pole Length (ft.)				
$E = D + 12"$, where E = Excavated Length										

DISTRIBUTION CONSTRUCTION STANDARDS

REV	DATE	ENG	DESCRIPTION
2	10/01/20	KR	Title Change; Comb. 02 20 03 01 & 02; Revised Notes; Added Constr. Notes
1	02/15/12	MJ	

INSTRUCTION(s):

1. Rock backfill consisting of compacted 1" minus rock or larger must be used for composite poles and is preferred for all 3-phase distribution and sub-transmission poles.
2. Clean Rock Shall Never Be Used As Backfill!
3. The backfilling procedures for rock and native soil backfill with a pole ground are as follows:
 - a. When using rock backfill the pole shall be lowered into the hole after 12" of earth backfill, which shall cover the ground coil, has been thoroughly tamped at the bottom. The rock backfill shall be placed in the hole in a maximum of 12-inch layers and tamped thoroughly before adding the next layer. Tamping shall be performed with hydraulic mechanisms. The top 6" of material around the pole shall be dirt to prevent rock spoils on private property. All wood poles shall be set plumb, unless otherwise directed, and shall be checked during backfilling to make sure that they remain plumb. The hole shall be excavated to a diameter at least 8" larger than the base diameter of the pole.
 - b. Where rock backfill is not feasible for wood poles, native soil may be used for backfill. The wood pole shall be lowered into the hole after loose dirt at the bottom has been thoroughly tamped. The earth backfill shall be placed in the hole in a maximum of 12-inch layers and tamped thoroughly before adding the next layer. Tamping shall be performed with hydraulic, hand-tamping, or air-tamping mechanisms. Soil shall be mounded at the ground line to cover natural future settling. All wood poles shall be set plumb, unless otherwise directed, and shall be checked during backfilling to make sure that they remain plumb. Extra soil shall either be removed from the site or spread evenly over area adjacent to the pole, if not landscaped.

**Excavated Earth Backfill
Wood Poles**

**Rock Backfill
Wood Poles**

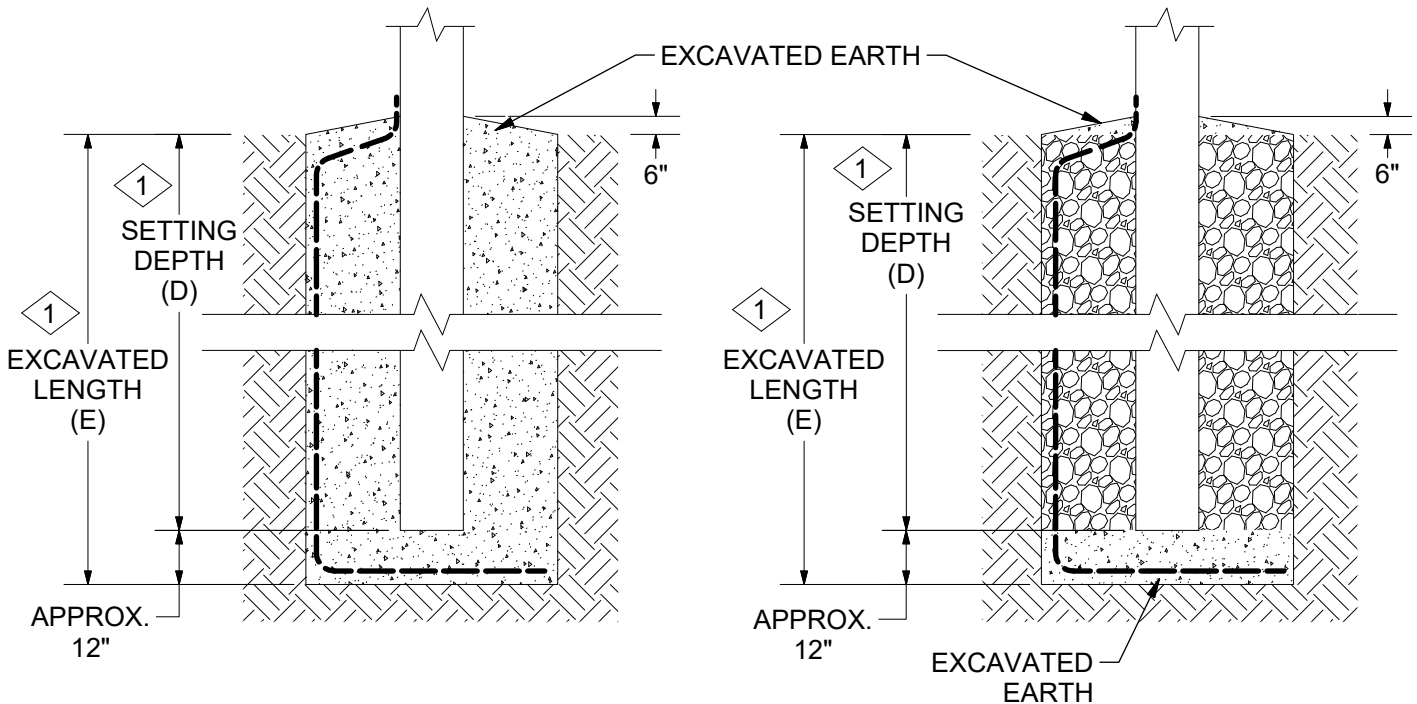

REV	DATE	ENG	DESCRIPTION
4	10/01/20	KR	Revised drawings and Notes
3	01/01/20	KR	

Rock Backfill Composite Poles

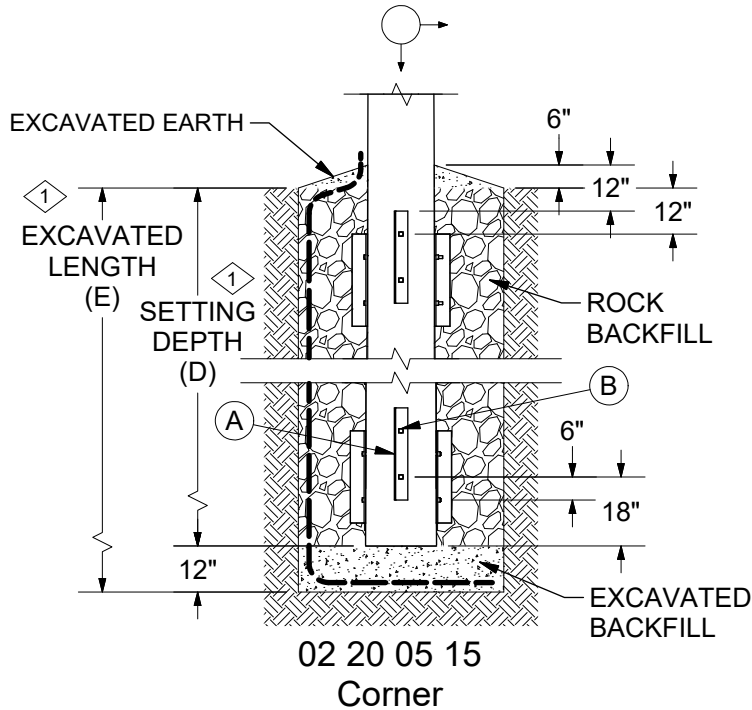
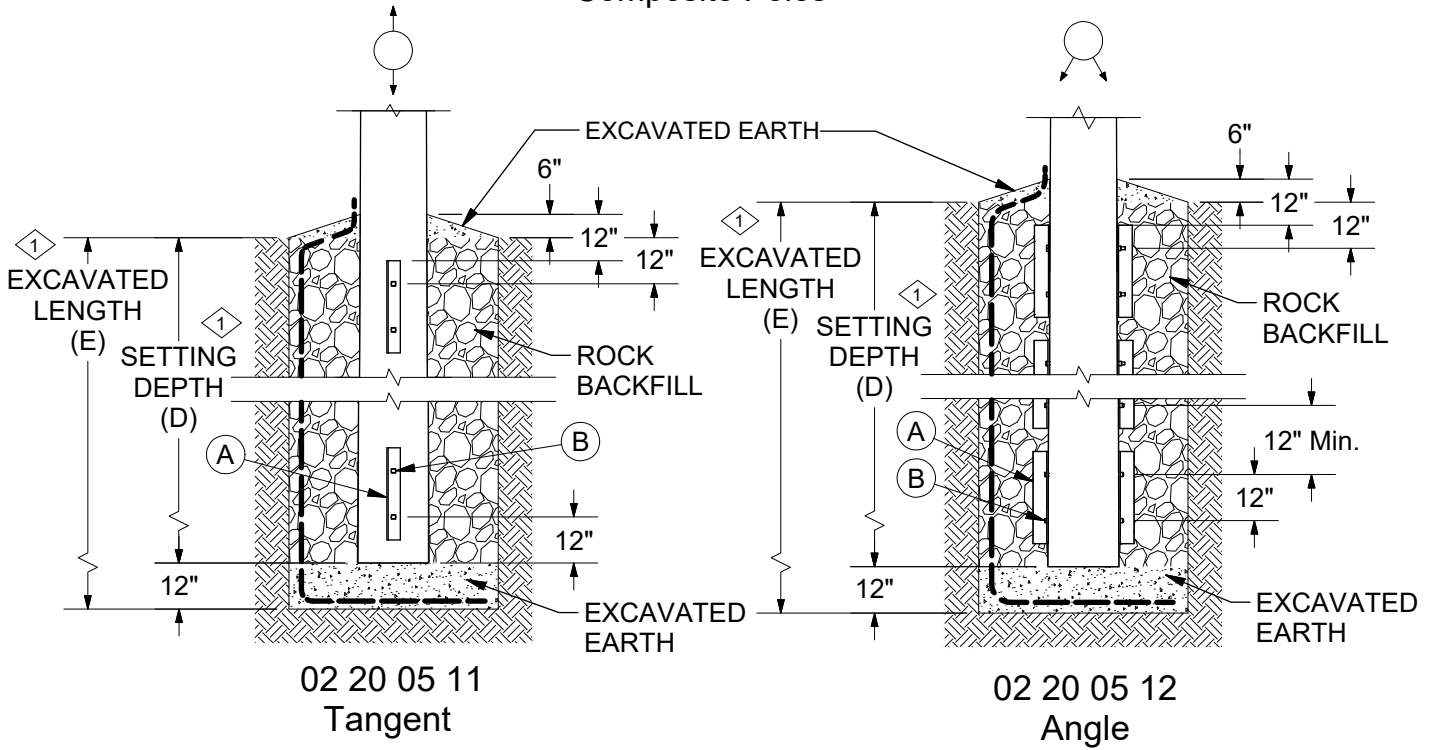

	ITEM	STK / DCS #	DESCRIPTION	02 20 05 **	11	12	15
2,3	A	23 06 126	Bracket, Angle, Fiberglass, 3 1/2" x 4" x 3/8" x 2'	4	8	8	8
2,3	B	23 52 118	Bolt, Mach., 3/4" x 20"	4	8	8	8

REV	DATE	ENG	DESCRIPTION
4	10/01/20	KR	Revised drawings and Notes
3	01/01/20	KR	

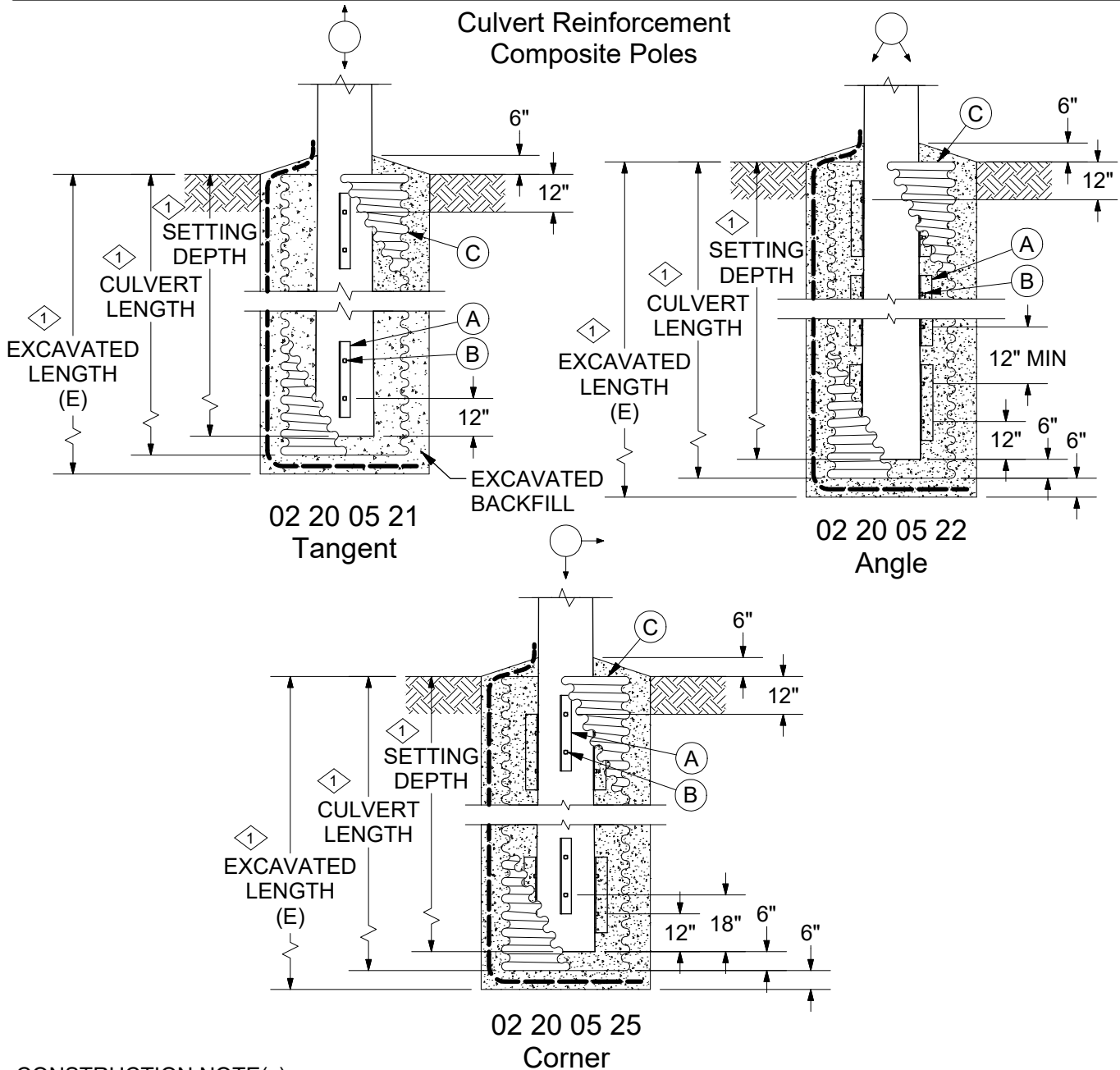

CONSTRUCTION NOTE(s):

1. See DCS **02 20 03 01** for most common wood and composite pole setting depths, and 02 00 04 02 for application specific setting depths. Poles without a pole ground do not require the extra excavated 12" of soil.
2. All storm structures require four brackets and super storm structures and switch poles require 8 brackets.
3. Angle brackets and additional bolts to be used on composite poles only.
4. Poles set in culverts shall be backfilled with 1" - 1.5" minus rock compacted in 12" or less lifts.

	ITEM	STK / DCS #	DESCRIPTION	02 20 05 **	21	22	25
2,3	A	23 06 126	Bracket, Angle, Fiberglass, 3 1/2" x 4" x 3/8" x 2'	4	8	8	
2,3	B	23 52 118	Bolt, Mach., 3/4" x 20"	4	8	8	
@	C	32 04 187	Pipe, Galv Stl, 18" Dia., 10'	1	1	1	
		32 04 188	Pipe, Galv Stl, 24" Dia., 10'	1	1	1	

**DISTRIBUTION
CONSTRUCTION STANDARDS**

REV	DATE	ENG	DESCRIPTION
4	10/01/20	KR	Revised drawings and Notes
3	01/01/20	KR	



POLES

Storm Hardening Structure

02 30 10 01

1 of 1

Composite poles are an ideal option for storm hardening due to the amount of deflection they have rotationally, which can absorb the impact of cascading events. These poles can be used in un-guyed tangent applications. The tables list the stock numbers used in different configurations to minimize or halt a cascade event for tangent applications only. The recommendation for Sub-transmission is to install a storm pole every 1/4 mile or every fifth pole. Installation of Super Storm Poles is every mile or one in every 20 poles or at a double dead-end structure. A heavily guyed wood structure can be substituted as a storm pole as it will not accelerate or start a cascade. Storm hardening shall be used for distribution where cascading problems have occurred in the past.

Table 1 - Distribution Circuit						
Height (ft.)	Stock Number					
	Single Phase		Three Phase			
			Single Circuit		Double Circuit	
	Storm Pole	Super Storm Pole	Storm Pole	Super Storm Pole	Storm Pole	Super Storm Pole
40'	41 40 012	41 40 014	-	-	-	-
45'	41 45 012	41 45 014	41 45 012	41 45 014	-	-
50'	-	-	41 50 012	41 50 014	41 50 014	41 50 826
55'	-	-	-	-	41 55 014	41 55 826

Table 2 - Sub-transmission Line						
Height (ft.)	Stock Number					
	Single Circuit 34kV / 69kV		34kV or 69kV with Underbuild 2 4			
			Single Circuit		Double Circuit	
	Storm Pole	Super Storm Pole	Storm Pole	Super Storm Pole	Storm Pole	Super Storm Pole
50'	41 50 014	41 50 826	-	-	-	-
55'	41 55 014	41 55 826	41 55 014	41 55 826	-	-
60'	41 60 014	41 60 826	41 60 014	41 60 826	-	-
65'	41 65 014	41 65 826	41 65 014	41 65 826	41 65 014	41 65 826
70'	41 70 014	41 70 826	41 70 014	41 70 826	41 70 014	41 70 826
75'	41 75 014	41 75 826	41 75 014	41 75 826	41 75 015	41 75 829
80'	41 80 015	41 80 829	41 80 015	41 80 829	41 80 015	41 80 829
85'	41 85 015	41 85 829	41 85 015	41 85 829	41 85 017	41 85 832
90'	41 90 017	41 90 832	41 90 017	41 90 832	41 90 017	41 90 832

DESIGN NOTE(s):

1. Storm hardening recommendations for H-Frame structures shall be one complete structure every mile. This will be a Super Storm Pole of the 14"/15" size up to 80' tall. From there it shall be a 15"/17" pole. Refer to composite pole stock number standard for stock codes.
2. OPGW static will increase the size of the pole above 70' tall. Due to the higher tensions this will constitute the larger structure for both Storm Poles and Super Storm Poles.
3. All Storm Poles are buried 10% of the pole height plus 2 feet (10%+2') deep. All Super Storm Poles are buried 10% of the pole height plus 3.5' (10%+3.5') deep.
4. Double circuit stock numbers are valid for applications with and without Underbuild.

**DISTRIBUTION
CONSTRUCTION STANDARDS**

REV	DATE	ENG	DESCRIPTION
2	10/01/20	KR	Revised tables to latest allowable sizes; Added Notes 1 thru 3
1	09/23/14	MJ	



POLES
Composite Switch Poles
Stock Codes

Height (Ft.)	Composite Pole Gang Operated Switch Pole Stock Numbers		
	Single Circuit 34kV / 69kV	34kV or 69kV with 12kV Underbuild	
		Single Circuit	Double Circuit
55'	4155826	-	-
60'	4160826	4160826	-
65'	4165826	4165826	4165826
70'	4170826	4170826	4170826
75'	4175829	4175829	4175829
80'	4180829	4180829	4180829
85'	4185829	4185829	4185832
90'	4190832	4190832	4190832
95'	4195832	4195832	4195832

DESIGN NOTE(s):

- All Composite Switch Poles are buried 10% of the pole height plus 3.5' (10%+3.5') deep. They will also include 8 angle brackets below grade per Standard 02 20 05 15.

REV	DATE	ENG	DESCRIPTION
1	10/01/20	KR	New Standard - Composite Switch Pole sizes
	xx/xx/xx	xxx	

The use of pole steps in Ameren Service Areas shall be on an as needed basis. The guidelines below must be adhered to in order to provide consistency and standardization across operating divisions.

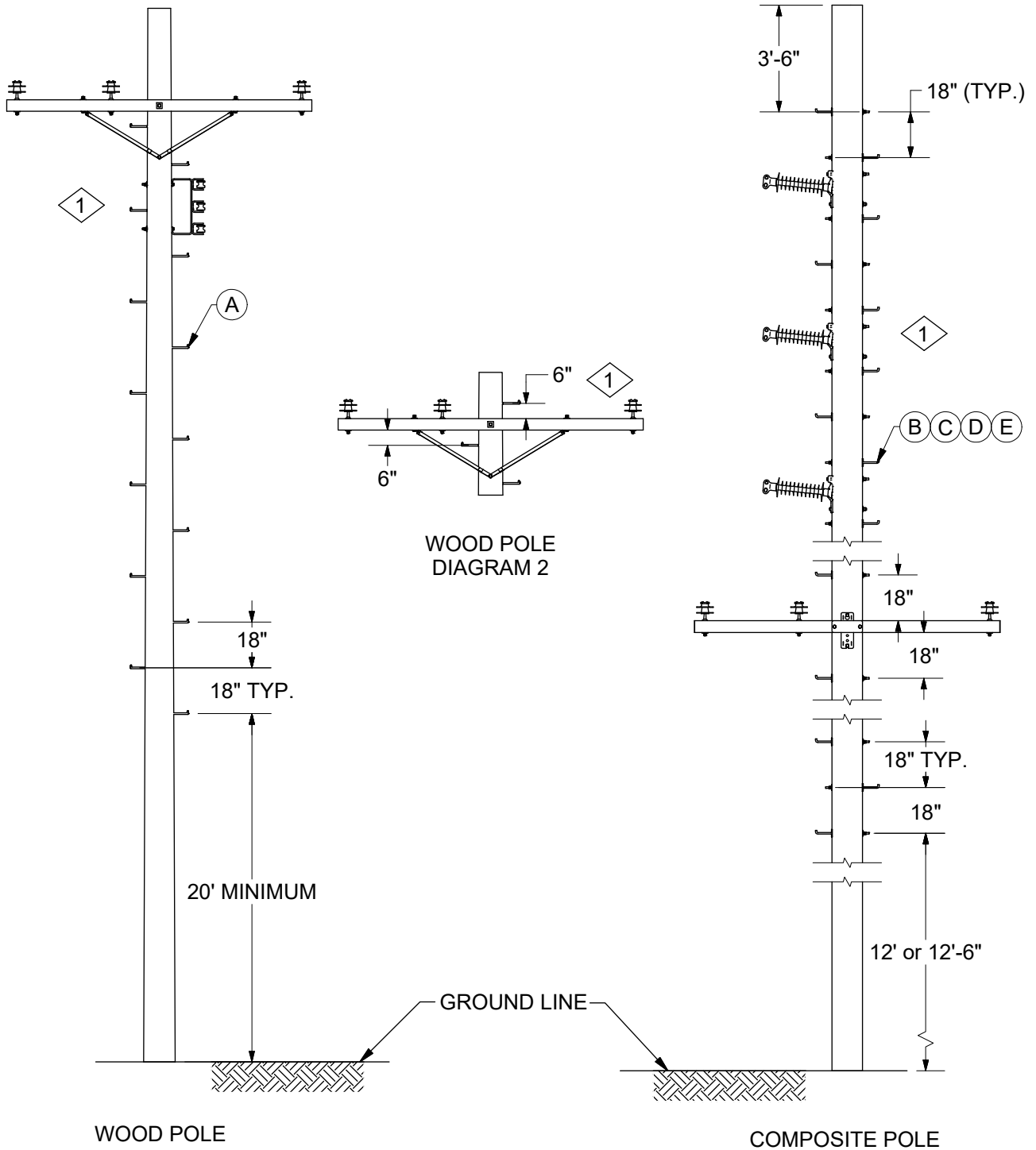

CAUTION: Pole steps must NOT be in contact with ground wires or other grounded objects.

REV	DATE	ENG	DESCRIPTION
2	10/01/20	KR	Revised Notes; Moved Wood & Composite Pole step stk #s to Sheet 2
1	12/09/15	MJ	



POLES

Pole Steps

02 40 32 **

2 of 2

CONSTRUCTION NOTE(s):

1. Locate Step on opposite side of closest phase.

Wood Pole	
Pole Size	Std. No.
0-40 Ft.	02 00 30 01
45-50 Ft.	02 00 32 02
55-60 Ft.	02 00 32 03
65-70 Ft.	02 00 32 04
75-80 Ft.	02 00 32 05
85-90 Ft.	02 00 32 06

Composite Pole	
Pole Dia.	Std. No.
11"	02 00 32 10
12"	02 00 32 09
14"	02 00 32 11

ITEM	STK / DCS #	DESCRIPTION	02	01	02	03	04	05	06	09	10	11
@	A 23 67 036	Step, Wood Pole, Hook Head, 5/8" X 10"	8	14	20	26	32	38	-	-	-	-
@	B 23 67 492	Step, Composite Pole, Permanent, 12" Diameter	-	-	-	-	-	-	-	#	-	-
@	C 23 67 506	Step, Composite Pole, Permanent, 11" Diameter	-	-	-	-	-	-	-	-	#	-
@	D 23 67 507	Step, Composite Pole, Permanent, 14" Diameter	-	-	-	-	-	-	-	-	-	#
@	E 23 17 466	Step, Composite Pole, Working Step, 11", 12", 14" Diameter	-	-	-	-	-	-	-	#	#	#

DESIGN NOTE(s):

2. Pole Steps

2.1 Poles shall not be stepped for any reason if any of the following apply:

- a. Poles are adjacent to paved areas and are bucket truck accessible.
- b. Poles are located on or adjacent to school property, playgrounds, athletic fields or similar locations where large numbers of people may assemble.
- c. Poles are located adjacent to or within 10 (ten) feet of structures or appurtenances such as porches, garages, sheds, fences, stairways or windows.

2.2 Poles that do not meet any of the above criteria may be stepped if any of the following apply:

- a. Switch poles where the switch cannot be operated using an extend stick.
- b. Terminal poles.
- c. Recloser or sectionalizer poles.
- d. Poles that the Construction Superintendent deems appropriate to step due to unusual conditions.

2.3 Leave pole steps on the pole unless safety concerns require removal.

3. Composite poles are fabricated without step holes unless Operating Center or Design Center communicates with supplier prior to ordering or delivery.

REV	DATE	ENG	DESCRIPTION
2	10/01/20	KR	Revised Notes; Moved Wood & Composite Pole step stk #s to Sheet 2
1	12/09/15	MJ	

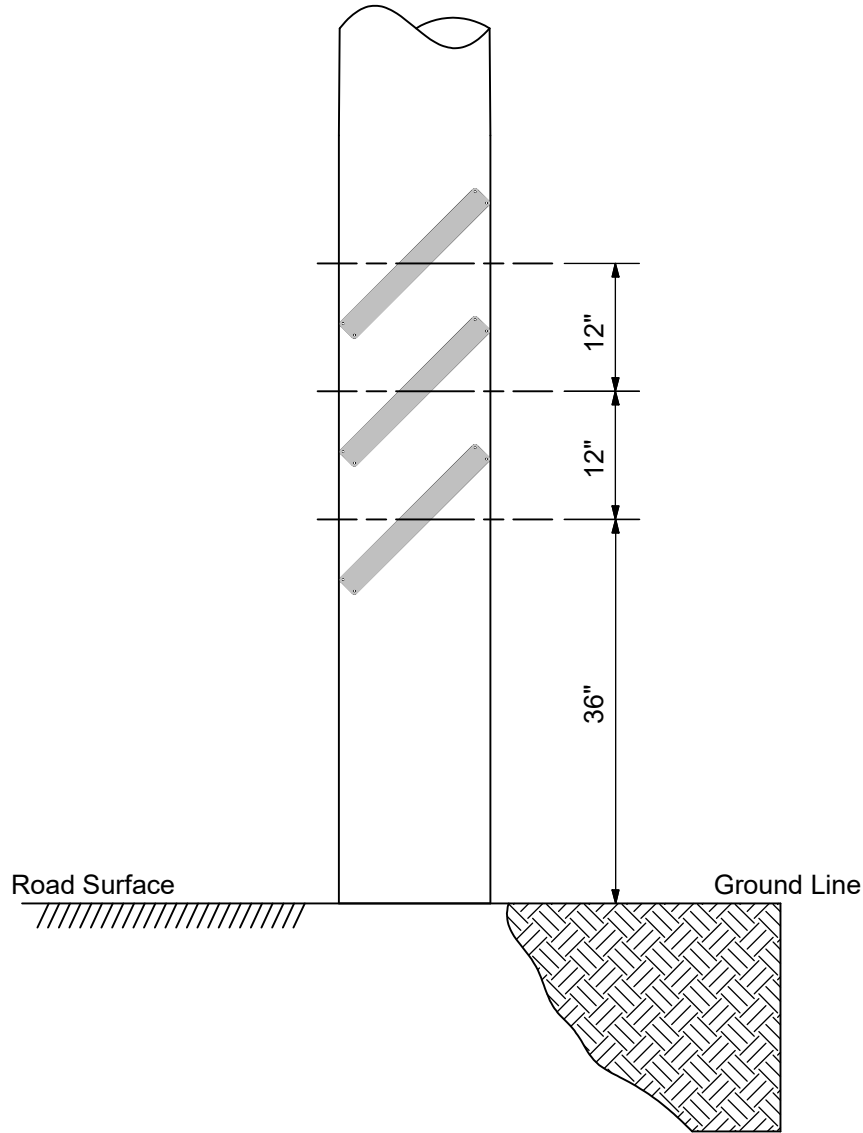

CONSTRUCTION NOTE(s):

1. Install the markers at 45° to the ground line and facing oncoming traffic. Lower ends of the diagonal markers must be toward road.
2. Markers must be positioned as specified to comply with manual of uniform traffic control devices (MUTCD) requirements.

ITEM	STK / DCS#	DESCRIPTION	02 40 43 **	00
A	16 06 258	Marker - Pole, Visibility		3
B	23 64 005	Nail - Roofing, 1 1/2" x 11 GA x 7/16 HD		12

REV	DATE	ENG	DESCRIPTION
2	10/01/20	KR	Converted to new format
1	10/19/11	MJ	

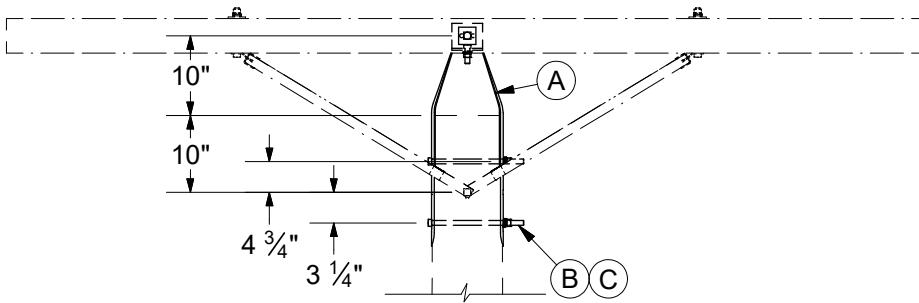

02 40 46 01
Single Arm

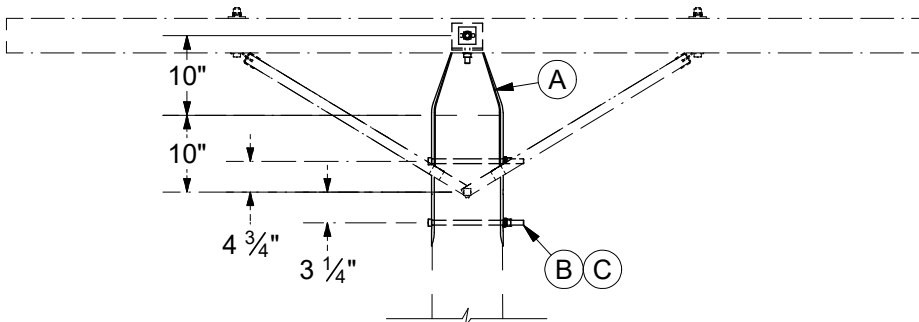
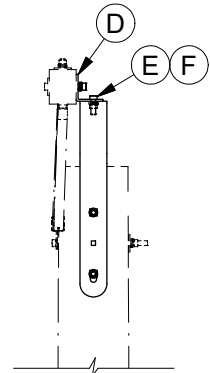

02 40 46 02
Double Arm

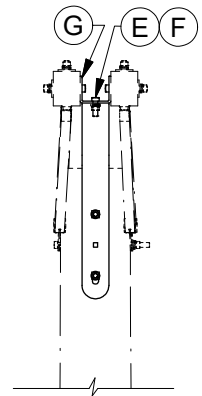

ITEM	STK / DCS #	DESCRIPTION	02 40 46 **	01	02
A	23 06 050	Bracket, Ridge Iron - 6-1/2" - 8" Dia.		1	1
B	23 52 065	Bolt, Mach., 5/8" x 12"		2	2
C	23 66 134	Lock Washer - 5/8" Double Coil		2	2
D	23 06 052	Bracket - Crossarm Support, Angle		1	-
E	23 52 049	Bolt, Mach., 5/8" x 2"		1	1
F	23 66 006	Washer - Lock 5/8"		1	1
G	23 06 051	Bracket - Crossarm Support, Double		-	1

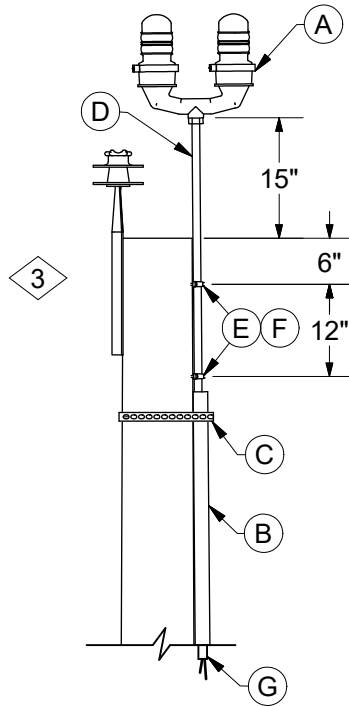

ITEM	STK / DCS #	DESCRIPTION	02 40 48 **	00
A	40 05 223	Fixture, Obstruction Light		1
B	12 01 230	Conduit - 1-1/2" Schedule 40 (8-ft.)		2
C	27 60 035	Strap, Iron Hanger		2
D	40 03 033	Conduit 1" Heavy Wall (36" Long)		1
E	40 53 021	Clamp - Pipe 1"		2
F	23 60 002	Lag Screw - 1/4" x 4"		2
G	18 61 055	Cable - 600V, 2-14 AWG ft.		20

DESIGN NOTE(s):

1. Structures within 20,000 ft. of a landing area may require an obstruction light. The Real Estate Department can help determine whether or not obstruction lights and/or marker balls are required in each specific location.
2. For 4kV and 12kV circuits vertical configuration shall be used in first position. On 12kV 3Ø circuits the pole phase shall be located 32" from the center of the pole.
3. Static wire pin, when required, may be attached in normal position.
4. For 34kV/69kV single circuit static wire construction use DCS **03 69 01 ****.
5. For 34kV/69kV double circuit static wire construction use DCS **03 69 02 ****.
6. Pole extension shall not be used on poles where obstruction lights must be installed.

REV	DATE	ENG	DESCRIPTION
2	10/01/20	KR	Converted to new format
1	09/23/15	MJ	

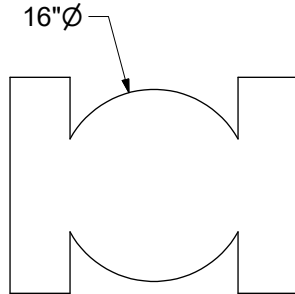

Flat View of Pole Cap

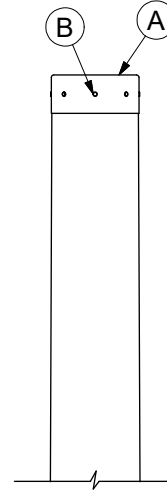

CONSTRUCTION NOTE(s):

1. Pole caps are required to be placed on poles cut off to accommodate other heights or sizes.
2. Steps for Installation:
 - a. Peel protective backing
 - b. Center and adhere to top of pole
 - c. Wrap tabs around pole and fold excess top over edges
 - d. Secure with Nails

ITEM	STK / DCS #	DESCRIPTION	02 40 49 **	00
A	54 17 470	16" Pole Top Cover		1
B	23 64 005	Nail - Roofing, 1-1/2" x 11 GA x 7/16" HD		8

NOTES