

# **UNDERGROUND CABLE SPLICE**

**41**

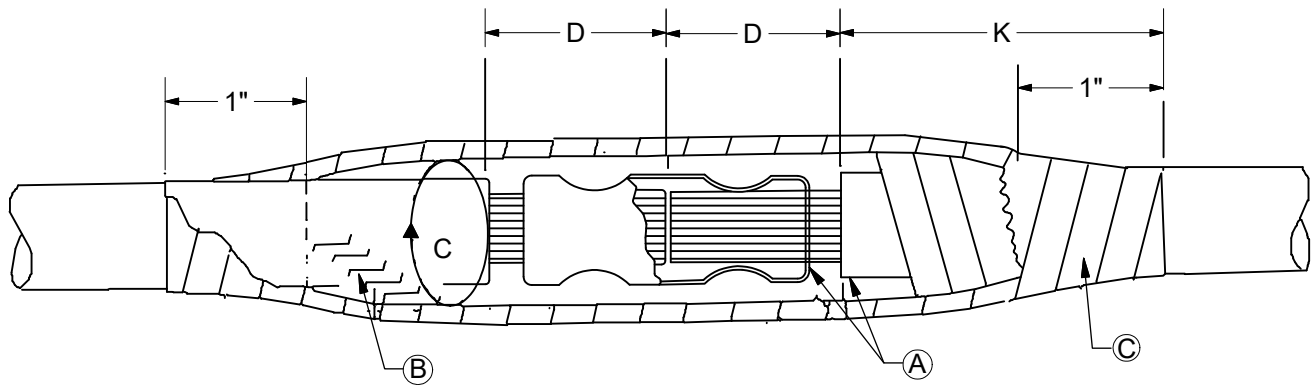


# UNDERGROUND CABLE SPLICE

## Table Of Contents

41 00 00 01
1 of 1

SINGLE CONDUCTOR RUBBER OR XLP JACKETED OR NON JACKETED, 600 V.....	41 14 31 **
SINGLE CONDUCTOR GEL WRAP SLEEVE, RUBBER OR XLP, 600 V.....	41 14 36 **
SINGLE CONDUCTOR 1/0, 3/0, 4/0, 350, & 500 kcmil INLINE SET SCREW CONNECTOR INSULATED WITH GEL WRAP SLEEVE, 600 V.....	41 14 37 **
STREETLIGHT STRAIGHT OR Y GEL WRAP SLEEVE - #6 CU/AL - #6 CU/AL OR #6 CU/AL - #10 CU, 600 V.....	41 15 31 00
SINGLE CONDUCTOR LONG REPAIR SPLICE #6 - 350 AL/CU, 600 V.....	41 15 32 01
1/0 - 750 CU NON-SHIELDED COLD-SHRINKABLE RUBBER SPLICE, 5 kV.....	41 24 30 **
TRIFURCATING: 3/C PILC TO 3 - 1/C EXTRUDED SOLID DIELECTRIC HEAT-SHRINKABLE, 5 kV.....	41 33 22 **
PREMOLDED #2 AL AND 1/0 AL CNX/CNR, 15 kV.....	41 34 34 **
PREMOLDED 4/0 AL CNX/CNR, 15 kV.....	41 34 35 **
PREMOLDED LONG REPAIR - 4/0 AL, CNX/CNR, 15 kV.....	41 34 36 **
PREMOLDED #2 AL TO 4/0 AL CNX/CNR, 15 kV.....	41 34 40 **
PREMOLDED SEPERARABLE #2 AL THROUGH 750 KCMIL CU OR AL, 15 kV, 35 kV.....	41 35 31 **
HOT TEST CAP 1/0 THRU 800 KCMIL 3 COND LEAD CABLE (BELTED OR SHIELDED), 5 kV, 15 kV.....	41 36 11 **
TRIFURCATING: 3/C PILC TO 3 - 1/C SOLID DIELECTRIC HEAT SHRINKABLE, 35 kV.....	41 43 22 **
1C PILC TO EXTRUDED SOLID DIELECTRIC HEAT SHRINKABLE, 35kV.....	41 44 21 **
PREMOLDED 1/0 AL, CNR, P, 35 kV.....	41 44 30 03
HOT TEST CAP 350 KCMIL OR 500 KCMIL 3 COND LEAD CABLE (BELTED OR SHIELDED), 35 kV.....	41 46 11 **
HEAT SHRINKABLE 69kV 500-750 AL KCMIL, 69 kV.....	41 54 30 **
COLD SHRINKABLE 350-750 KCMIL, 15 kV, 35 kV.....	41 64 30 00



**INSTRUCTIONS:**

1. Jackets over the insulation are considered a part of the insulation and are not to be removed.
2. Remove insulation back the required length (D) and install crimp sleeve and, if necessary, reducers.
3. Apply rubber tape half lapped to circ. (C) taping gradual slopes at each end. Stretch tape to only 3/4" of its original width. CAUTION: When splicing aluminum cable, wipe off all excess inhibitor.
4. Apply two half-lapped layers of plastic tape extending one inch beyond the original taping and length (K) from from the insulation cut off.

**CONSTRUCTION NOTE(s):**

1. A #2 AWG copper splicing sleeve (Stock #17 60 273) may be substituted for this sleeve.

Copper Cables					
DCS#	Size	Dimensions (In)			Ins. (mils)
		D	K	C	
01	#2	1.5	3	2.7	180
02	1/0	2	3	3.6	180
03	4/0	2	3	3.6	180
04	500	2.5	4	4.2	180

Aluminum Cables					
DCS#	Size	Dimensions (In)			Ins. (mils)
		D	K	C	
05	1/0	1.25	3	2.7	180
06	3/0	1.75	3	3.2	180
07	350	2	4	4.2	180
-	-	-	-	-	-



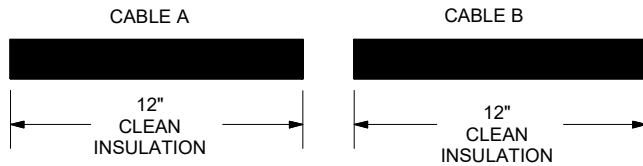
# UNDERGROUND CABLE SPLICE

Single Conductor Rubber or XLP  
Jacketed or Non-Jacketed

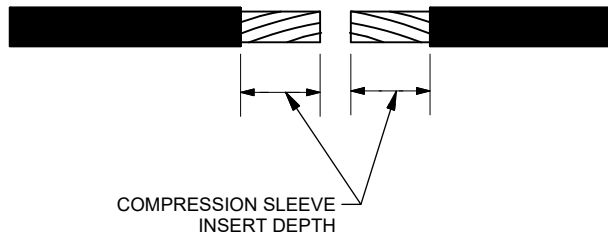
<b>41 14 31 **</b>
<b>600 V</b>
<b>2 of 2</b>

	ITEM	STK / DCS #	DESCRIPTION	41 14 31 **	COPPER				ALUM.		
					01	02	03	04	05	06	07
1	A	17 63 127	Sleeve-Compression, #2, Cu.		1	-	-	-	-	-	-
		17 54 219	Reducer-#4/0 to #1/0		-	2	-	-	-	-	-
		17 63 030	Sleeve-Compression, 4/0 Cu.		-	1	1	-	-	-	-
		17 63 032	Sleeve-Compression, 500 kcmil, Cu.		-	-	-	1	-	-	-
		17 63 133	Sleeve-Compression, 1/0, Al		-	-	-	-	1	-	-
		17 63 125	Sleeve-Compression, 3/0, Al		-	-	-	-	-	1	-
		17 63 124	Sleeve-Compression, 350 kcmil, Al		-	-	-	-	-	-	1
	B	25 53 080	Tape-Rubber, 3/4"		1	1	1	1	1	1	1
	C	25 53 055	Tape-Plastic		1	1	1	1	1	1	1
		413	Op Code Splice Up to 1000 V		1	1	1	1	1	1	1

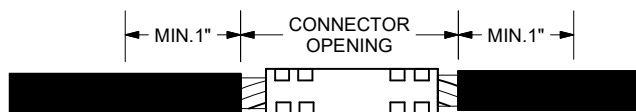
REV	DATE	ENG	DESCRIPTION
3	01/01/23	EJB	Converted to New Format
2	12/08/09	EJB	



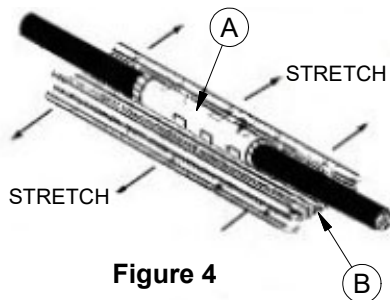
**Figure 1**



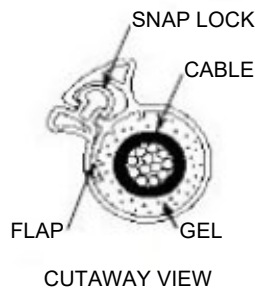
**Figure 2**



**Figure 3**



**Figure 4**



**Figure 5**



**Figure 6**

## INSTRUCTIONS:

1. Thoroughly clean the cable insulation. Clean 12" of Insulation on Cable "A" and 12" of insulation on Cable "B". See Figure 1.
2. Check the insert depth of the compression sleeve being used. Remove the length of cable insulation on each cable that corresponds to the insert depth of the compression sleeve. See Figure 2.
3. Install the compression sleeve. Make as many crimps as possible without overlap. Use the dies shown in the table. Remove the excess flash and inhibitor. See Figure 3.
4. Prestretch gel wrap sleeve as shown in Figure 4. Warming the sleeve will make it easier to install in cold weather.
5. Center the connector in the sleeve, then wrap the sleeve around the cable and connector. Start at one end, compress the snap locks over the entire length of the sleeve. Ensure that flaps seat under snap locks as shown in Figure 5.
6. Install cable ties at outer most notches of the snap locks. Splice is complete and ready for use. See Figure 6.

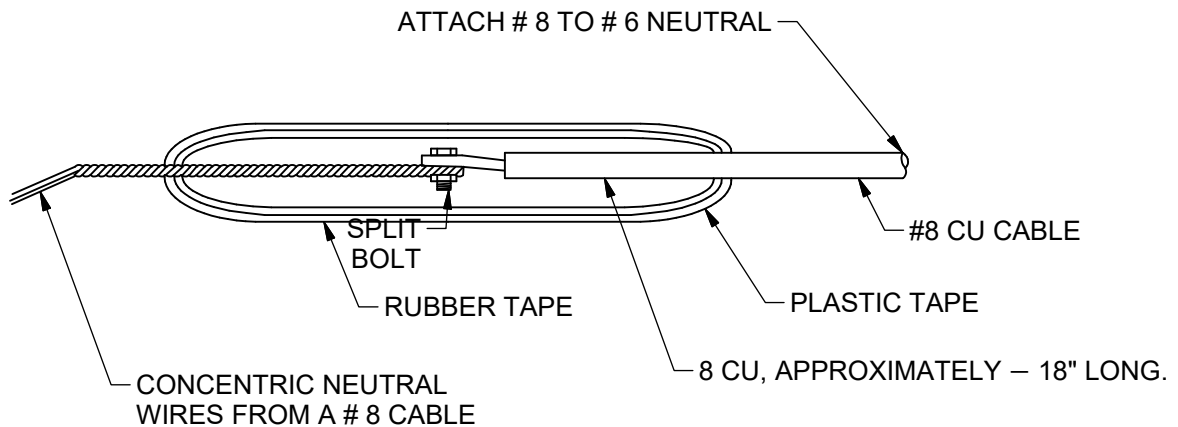
REV	DATE	ENG	DESCRIPTION
7	01/01/23	EJB	Converted to New Format
6	08/08/08	HLH	

**INSTRUCTIONS - #8 CNP TO #8 CNP:**

1. Follow the instructions on sheet 1.
2. Unwind the concentric neutral wire from each cable. Remove enough cable to provide a sufficient length of concentric neutral wire for connecting across a splice.
3. Clean the cables.
4. Check the insert depth of the compression sleeve being used. Remove the installation from each cable that corresponds to the insert depth of the compression sleeve.
5. Install the compression sleeve using the "J" groove on the Nicopress 53-XPJ tool. Apply three crimps per end.
6. Install gel wrap sleeve as shown on sheet 1.
7. Connect concentric neutral wires together across the splice with a split bolt.

**INSTRUCTIONS - #8 CNP TO #6 AL/CU:**

1. Follow instructions on sheet 1.
2. Install the #8 to #6 compression sleeve (Stock #17 60 363).
3. Attach the concentric neutral wires to the #6 Al/Cu neutral cables as follows:
  - a. Unwind concentric neutral from the end of the #8 cable and twist the ends of the concentric together. Obtain a 18" piece of #8 cable with concentrics removed. Strip approximately 2" of insulation from one end of the short piece of #8 cable.
  - b. Using Stock #17 54 003, join the concentrics to the short piece of #8 cable. After covering this connection with two layers of 1/2" lapped rubber tape, apply three layers of 1/2" lapped plastic tape.
  - c. Attach the other end of the short piece of #8 cable to the #6 neutral cable. This connection shall be made according to the instructions shown above. The #6 neutral will be identified by yellow insulation, yellow stripes, or ribs. See Figure 7.



**FIGURE 7**

REV	DATE	ENG	DESCRIPTION
7	01/01/23	EJB	Converted to New Format
6	08/08/08	HLH	



# UNDERGROUND CABLE SPLICE

Single Conductor Gel Wrap Sleeve, Rubber or XLP

<b>41 14 36 **</b>
<b>600 V</b>
<b>3 of 3</b>

ITEM	STK # /DCS	DESCRIPTION 36 **	41	14	01	02	03	04	05	06	07	08	09	10	11	12	13	14
A	17 63 133	Sleeve-Compression, 1/0 Al.	1	-	-	-	-	-	-	-	-	-	-	-	-	-	-	-
	17 63 138	Sleeve-Compression, 1/0 to 3/0 Al.	-	1	-	-	-	-	-	-	-	-	-	-	-	-	-	-
	17 63 125	Sleeve-Compression, 3/0 Al.	-	-	1	-	-	-	-	-	-	-	-	-	-	-	-	-
	17 63 124	Sleeve-Compression, 350 Al.	-	-	-	1	-	-	-	-	-	-	-	-	-	-	-	-
	17 63 144	Sleeve-Compression, 4/0 Al.	-	-	-	-	1	-	-	-	-	-	-	-	-	-	-	-
	17 63 143	Sleeve-Compression, 1/0 to 4/0 Al.	-	-	-	-	-	1	-	-	-	-	-	-	-	-	-	-
	17 63 145	Sleeve-Compression, 3/0 to 4/0 Al	-	-	-	-	-	-	-	1	-	-	-	-	-	-	-	-
	17 63 141	Sleeve-Compression, 3/0 to 350 Al.	-	-	-	-	-	-	-	-	1	-	-	-	-	-	-	-
	17 60 362	Sleeve-Compression, 6 Al./Cu.	-	-	-	-	-	-	-	-	-	-	1	-	-	-	-	-
	17 63 142	Sleeve-Compression, 750 kcmil Al	-	-	-	-	-	-	-	-	-	-	-	1	-	-	-	-
	17 63 032	Sleeve-Compression, 500 kcmil Cu	-	-	-	-	-	-	-	-	-	-	-	-	1	-	-	-
	17 60 360	Sleeve-Compression, 750 kcmil Cu	-	-	-	-	-	-	-	-	-	-	-	-	-	1	-	-
	17 60 102	Sleeve-Compression, #8 Cu	-	-	-	-	-	-	-	-	-	-	-	-	-	-	1	-
	17 60 363	Sleeve-Compression, #8 Cu to #6 Al/Cu	-	-	-	-	-	-	-	-	-	-	-	-	-	-	-	2
	17 54 003	Connector-Split Bolt	-	-	-	-	-	-	-	-	-	-	-	-	-	-	1	1
B	17 62 215	Wrap - Gel, 10" Long	1	1	1	1	1	1	1	1	1	1	-	-	-	-	-	
	17 62 217	Wrap - Gel, 8" Long	-	-	-	-	-	-	-	-	-	-	1	-	-	-	1	1
	17 62 282	Wrap - Gel, 12" Long	-	-	-	-	-	-	-	-	-	-	-	1	1	1	-	-
	405	OP Code Splice 1/0 to 350 AL	1	1	1	1	1	1	1	1	1	1	1	-	-	-	-	
	406	OP Code Splice 1000 Str.	-	-	-	-	-	-	-	-	-	-	-	1	1	1	1	1

REV	DATE	ENG	DESCRIPTION
7	01/01/23	EJB	Converted to New Format
6	08/08/08	HLH	

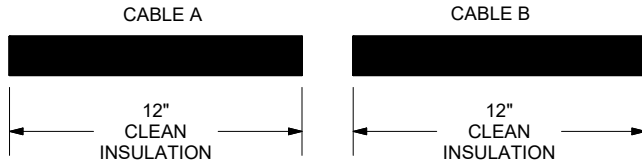


Figure 1

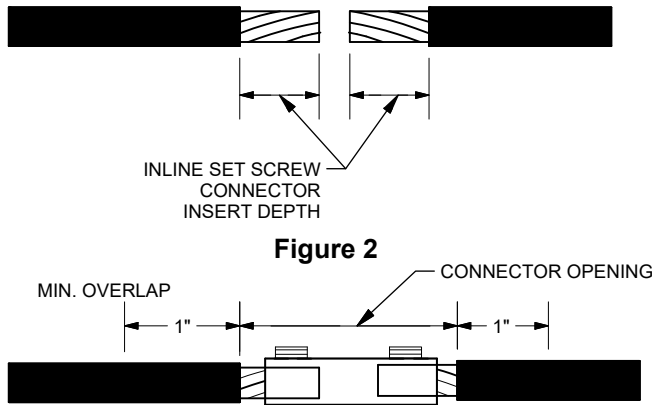


Figure 3

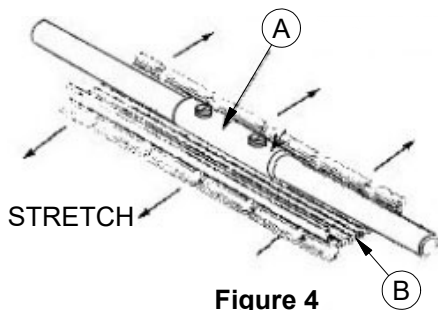


Figure 4

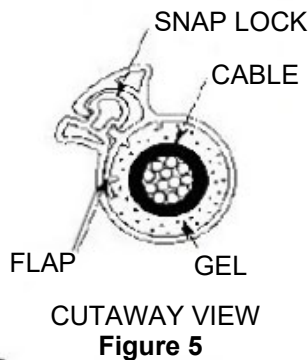


Figure 5

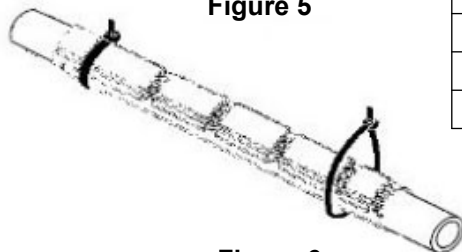


Figure 6

## INSTRUCTIONS:

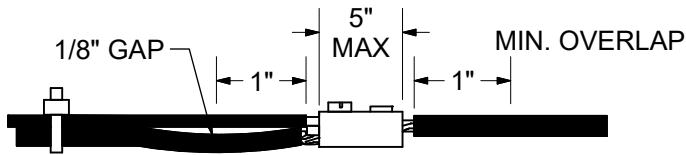
1. Thoroughly clean the cable insulation. Clean 12" of insulation on Cable "A" and 12" of insulation on Cable "B". See Figure 1.
2. Check the insert depth of the inline set screw connector. Remove the length of cable insulation on each cable that corresponds to the insert depth of the connector. See Figure 2. Remove surface oxides from the exposed conductors with a wire brush. Coat the cleaned conductors with oxide inhibitor (Stock #31 59 058).
3. Insert cables into the connector. Tighten the set screws using a 5/16" allen wrench. To obtain sufficient torque it may be necessary to hold the connector with a large crescent wrench. See Figure 3.
4. Prestretch the Gel Wrap sleeve will make it easier to install in cold weather. See Figure 4.
5. Center the connector in the sleeve then wrap the sleeve around the cable and connector. Start at one end. Compress the snap locks over the entire length of the sleeve. Ensure that flaps seat under snap locks as shown in Figure 5.
6. Install cable ties at outermost notches of snap locks. Splice is complete and ready for use. See Figure 6.

## CONSTRUCTION NOTE(S):

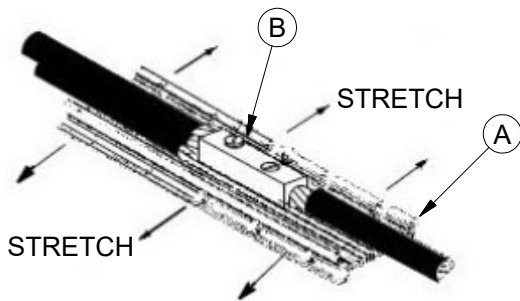
1. Warming the sleeve will make it easier to install in cold weather.

ITEM	STK / DCS #	DESCRIPTION	41 14 37 **	01	02
A	17 64 204	Connector - Inline Set Screw 1/0 - 350 kcmil		1	-
	17 54 972	Connector - Inline Set Screw 3/0 - 500 kcmil		-	1
B	17 62 215	Wrap - Gel, 10" Long		1	-
	17 62 282	Wrap - Gel, 12" Long		-	1
	405	Op Code Splice 1/0 to 350 AL		1	1

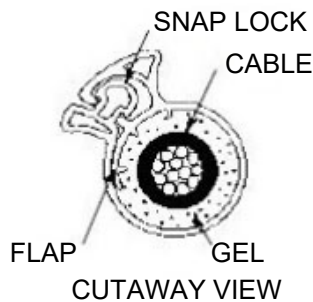




**Figure 1**



**Figure 2**



**Figure 3**



**FIGURE 4**

**INSTRUCTIONS:**

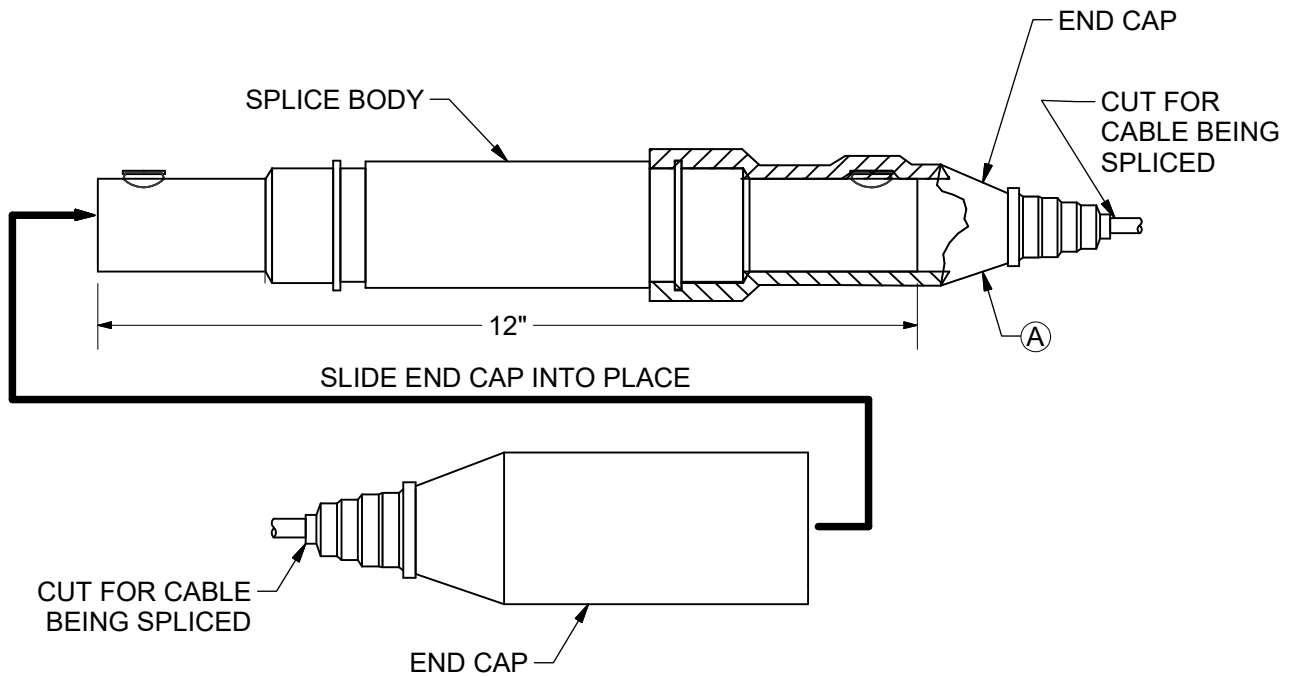
1. Remove 1" of insulation from each of the cables. Clean the conductors.
2. Install the connector and wipe off any excess inhibitor.
3. Clean the cables as required, and apply a small piece of gel pad around one of the cables of the "Y". Omit this step if making a straight splice.
4. Position a wire tie around the two cables as shown in Figure 1. Omit this step if making a straight splice.
5. Pre stretch the gel wrap sleeve and position it around the cables with the connector centered. See Figure 2.
6. Starting at one end of the gel wrap sleeve compress the snap locks over the entire length of the sleeve. Ensure that flaps seat under snap locks as shown in Figure 3.
7. Install the two wire ties in the notches of the snap locks. Splice is complete and ready for use. See Figure 4.

**CONSTRUCTION NOTE(s):**

1. Warming the gel wrap sleeve will make it easier to install in cold weather

ITEM	STK / DCS #	DESCRIPTION	41 15 31 **	00
A	17 62 217	Wrap - Gel, 8" Long		1
B	17 51 233	Connector - Wire St. Lt		1
@ C	17 62 216	Gel Wrap Pad - 2" x 8"		1
	405	Op Code Splice 1/0 to 350 AL		1

REV	DATE	ENG	DESCRIPTION
004	01/01/23	EJB	Converted to New Format
003	08/08/08	HLH	



**INSTRUCTIONS:**

1. Check insert depth of connector and remove required cable insulation. DO NOT KNICK THE CONDUCTOR.
2. Cut appropriate steps on the end caps to match the conductor size.
3. Install silicone grease on the cables and slide the end caps onto the cables.
4. Remove surface oxides from the exposed conductors with a wire brush.
5. Coat the exposed conductors with oxide inhibitor (Stock #31 59 058).
6. Insert cables into the connector ports until they hit the stops.
7. Tighten the set screw using a 5/16" allen wrench.
8. Complete the splice by sliding the splice end caps onto the splice body.

ITEM	STK / DCS #	DESCRIPTION	41 15 32 **	01
A	17 62 193	Splice - Repair, #6 - 350 kcmil AL. or CU.		1
	405	Op Code Splice 1/0 to 350 AL		1

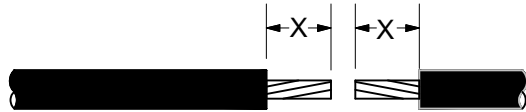


Figure 1

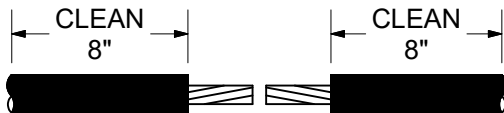


Figure 2

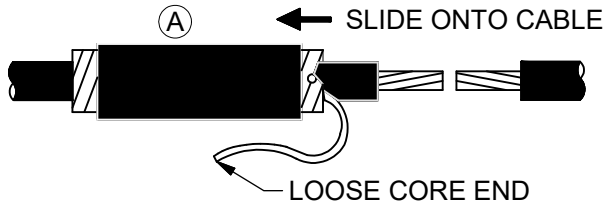


Figure 3

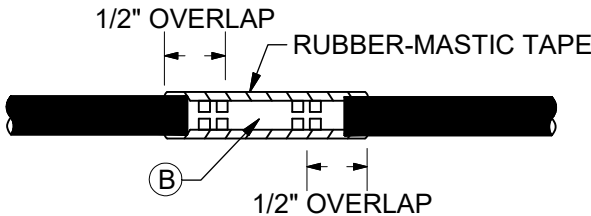


Figure 4

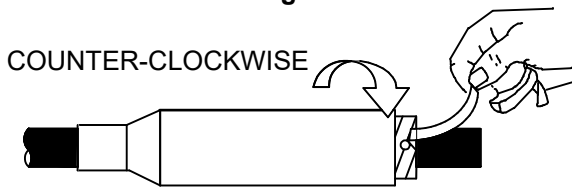


Figure 5

## INSTRUCTIONS:

1. Remove the insulation/jacket as shown in Figure 1. "X" dimension is the insert depth of the connector being used. The connectors, used on 350 kcmil and 750 kcmil cables, shall not exceed a length of 6-1/4". The connector, used on 1/0 cable, shall not exceed a length of 4-1/2".
2. Clean the cable insulation/jacket with the cleaning pads provided. See Figure 2.
3. Slide cold shrink splice onto one of the cables. See Figure 3.
4. Install compression sleeve.
5. Overwrap the installed connector with the rubber mastic tape provided. Apply the tape with the mastic side in towards the connector. Use the tape to build up the thickness to the level of the cable insulation then overlap the tape 1/2" onto the insulation. **DO NOT** apply an excess amount of the rubber mastic tape. See Figure 4. The rubber mastic tape should be stretched during installation, so that its width is reduced to approximately 1-1/2" or less.
6. Center the splice over the connector area. Remove the core by unwinding counter-clockwise, starting with the loose core end. An occasional tug of the core strand while unwinding will aid in core removal. Splice is complete after the core is removed. See Figure 5.

ITEM	STK / DCS #	DESCRIPTION	41 24 30 **	01	02	03
A	17 55 301	Splice, Straight, 5 kV, #2-300 kcmil		1	-	-
	17 55 300	Splice, Straight, 5 kV, 350 kcmil-750 kcmil		-	1	1
B	17 60 357	Sleeve, Compression, 1/0		3	-	-
	17 60 359	Sleeve, Compression, 350 kcmil		-	3	-
	17 60 360	Sleeve, Compression, 750 kcmil		-	-	3
	402	Op Code Cable Set-Up		3	3	3

### DESIGN NOTE(s):

1. Quantities shown are for making three joints

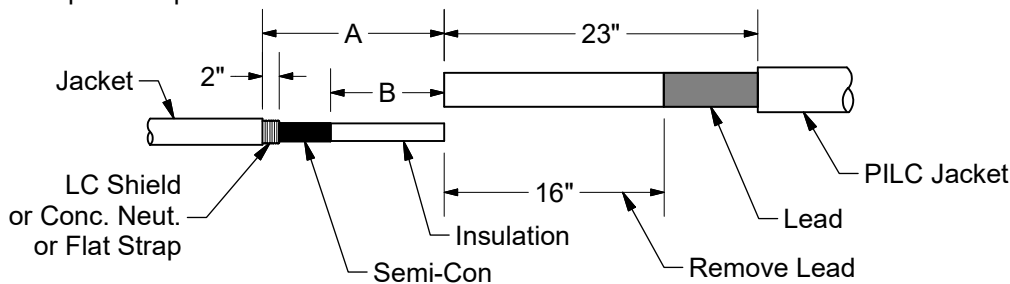
## INSTRUCTIONS

### 1. HEAT SHRINK BASICS

- Adjust the flame so that it is an overall 12" bushy flame.
- Apply outer 3" to 4" tip of the flame to heat-shrinkable material with a rapid brushing motion.
- Unless otherwise instructed start shrinking tubes at the center working the flame around all sides of the tubes to apply uniform heat.
- Concentrate on heating the back of the tubes as well as the front of the tubes.
- If it is necessary to interrupt the shrinking process and the tubes cool, you must reheat prior to shrinking the next tube.
- Inspect all installed tubes. Reheat any flat spots or wrinkles, paying particular attention to the back of the splice.

### 2. PREPARE CABLES

Secure end of flat strip, concentric neutral, or LC shield with a length of copper foil tape or minimal width of plastic tape.

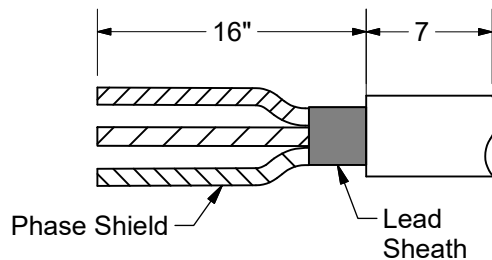


IF THE LEAD IS UNJACKETED, MARK THE PILC CABLE AS SHOWN

CABLE SIZE	A (IN)	B (IN)
1/0 <sup>3</sup> – 4/0 <sup>3</sup> PILC TO 3-#2, 3-1/0 OR 3-4/0	10	5
350 <sup>3</sup> PILC TO 3-350, OR 3-4/0	12	5-1/2
800 <sup>3</sup> PILC TO 3-750	12	5-1/2

### 3. PREPARE AND REMOVE LEAD SHEATH

- Remove lead oxide from the lead sheath and clean with an approved solvent. Remove the lead sheath as shown.



#### B. Phase Holding:

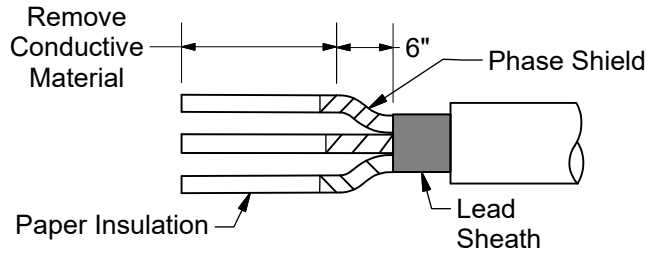
If an existing 3/C PILC cable is being cut and spliced to three new single conductor cables, "Phase Holding" may be required. After opening the lead sheath to expose the shielded phase conductors, place several wraps of colored tape around each phase before cutting the conductors. Use "white" to signify the "Held Phase A", blue to signify the "Held Phase B" and "red" to signify the "Held Phase C". The phase colors do not identify the actual phases but they represent the "Held Phase" of the system.

Due to the covering of the phases during the preparation of the splice, it will be necessary to move the markers several times throughout the splicing process. Each time the "Phase Holding" tape is to be moved to a new location, "Phase Holding" will be noted in the installation instructions.

If "Phase Holding" is not a requirement for this splice, then the "Phase Holding" comments should be ignored.

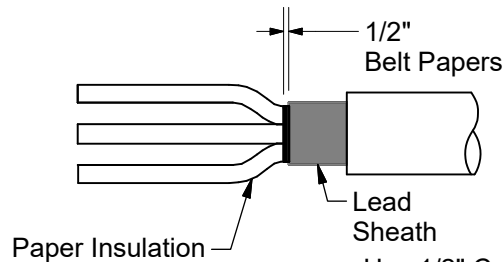
## 4. REMOVE SHIELD

- Cut back any bedding and/or shield tapes over all three phases to three phases to the lead sheath cutback.
- Cut back phase shields and remove any conductive material from paper insulation as shown.



Tape phase shields at edge to prevent unwrapping. DO NOT use string. Use one wrap of colored "phase holding" tape or plastic tape.

If Belted PILC Cable  
Remove Belt Papers as Shown

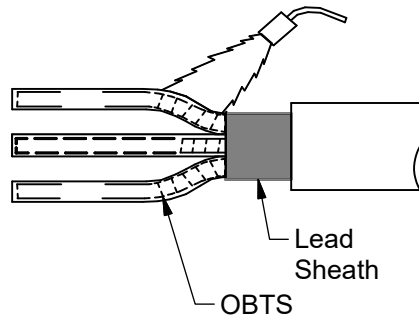


Use 1/2" Constant Tension Clamp to Obtain Clean Tear at Lead Sheath Cutback.

## 5. POSITION AND SHRINK OIL BARRIER TUBES (OBT)

- Place an oil barrier tube over each phase, butted to the lead sheath cutback.
- Shrink the OBT's in the crotch area first. After the crotch is done, shrink one tube at a time.
- Inspect the installed OBT's. The OBT's should have a smooth, wrinkle-free surface after shrinking. Reheat to smooth any wrinkled areas.

- OBT may shrink 1/4" - 1/2" away from lead sheath cutback. This is okay.
- To achieve a smooth wrinkle-free installation, use a reduced flame to install the thin-walled OBT's.

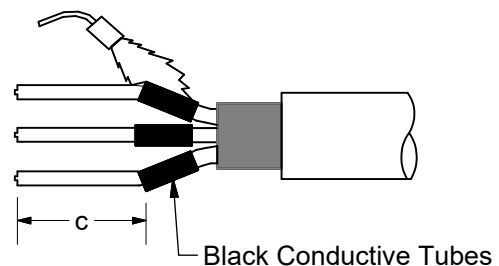


Phase Holding: Wrap a layer of "Phase Holding" tape to the connection end of the OBT before positioning and shrinking the Black Conductive Tubes.

## 6. POSITION AND SHRINK BLACK CONDUCTIVE TUBES

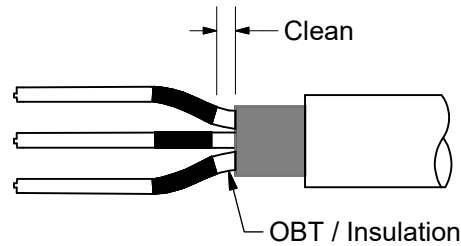
- Place a black conductive tube over each phase and position as shown.
- Shrink the tubes in place starting at the end nearest to the center of the splice.

CABLE SIZES	C (IN)
1/0 <sup>3</sup> and 4/0 <sup>3</sup> PILC	6
350 <sup>3</sup> and 800 <sup>3</sup> PILC	6-1/2

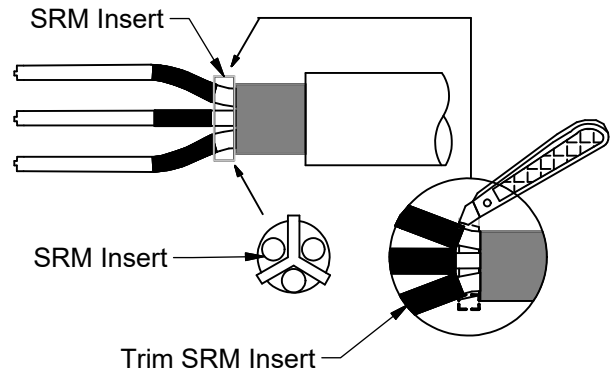


## 7. CLEAN OBTS AND INSTALL SRM INSERT

- A. Using an approved solvent, clean the OBT/insulation, as shown.

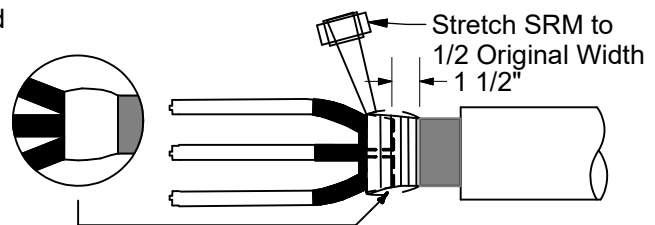


- B. Assemble SRM insert per box instructions.  
C. Spread the phases and position the SRM insert as shown. The SRM insert is packaged inside the conductive breakout.  
D. Trim SRM insert to extend 1/8" beyond each phase.  
E. Reclean the lead sheath using an approved solvent.



## 8. INSTALL OIL SEAL

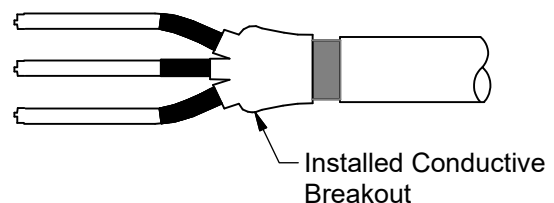
- A. Mark the lead sheath 1-1/2" from the end.  
B. Remove the backing from one side of a long strip of SRM. Roll the SRM and remaining backing strip into a convenient size.  
C. While removing the remaining backing strip, tightly wrap the SRM from the mark on the lead sheath to the outer edge of the SRM insert.  
D. Four to six strips of SRM should be used to build the SRM to the shape down.



- a. The SRM will stick better if the lead sheath is preheated.  
b. **DO NOT** over apply SRM, the finished diameter must not exceed that of the breakout boot.

## 9. POSITION AND SHRINK CONDUCTIVE BREAKOUT

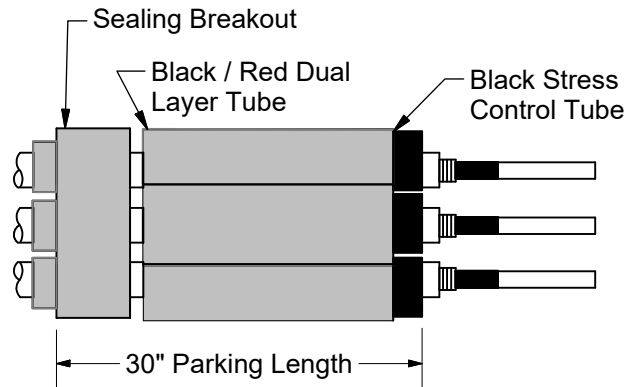
- A. Position the conductive breakout over the SRM so that the inside butts up hard against the SRM.  
B. Shrink the conductive breakout in place starting at the fingers and working toward the other end.  
C. After the breakout has shrunk, continue to apply heat until the breakout has a smooth, uniform surface.



Phase Holding: After breakout is cool, apply "Phase Holding" tape to the fingers of the cable breakout (last and final location for "Phase Holding" tape).

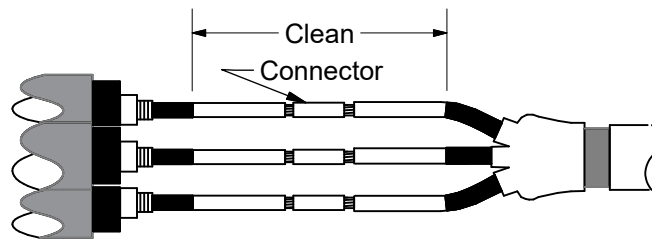
## 10. POSITION SPLICE COMPONENTS ON SOLID DIELECTRIC CABLES

- A. Clean 30" of cable jacket.
- B. Place sealing breakout over the cables with the fingers pointing away from the splice center.
- B. Place one set of nested tubes over each clean cable.



## 11. REMOVE INSULATION AND INSTALL CONNECTORS

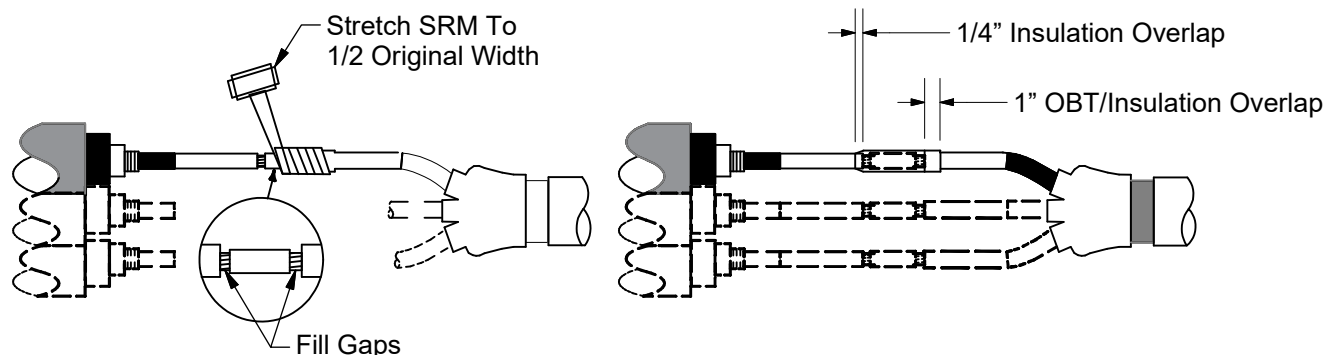
- A. Determine the insert depth of the connector.
- B. The insulation cutback should equal the connector insert depth plus 1/4".
- C. Install the connectors. Protect the OBT's, if using soldered connector by wrapping them with cotton or glass fiber tape.
- D. Make sure connections are smooth.
- E. Using an approved solvent, clean the insulation as shown. Pay particular attention to the OBT/insulation surface.



## 12. APPLY SRM OVER CONNECTOR

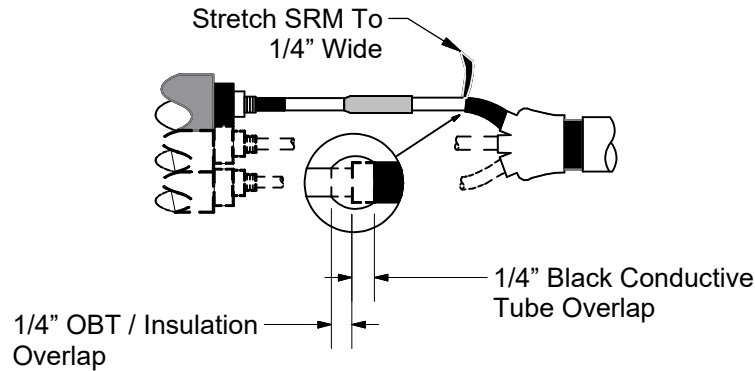
(Complete steps 12 and 13 working on one phase at a time.)

- A. Remove backing from one side of a long strip of SRM, roll the SRM and remaining backing strip into a convenient size.
- B. While removing the remaining backing strip, tightly wrap the SRM around the connector and exposed conductor. Be sure to fill the gaps and low spots around the connector.
- C. Continue to wrap the SRM onto the insulation as shown.
- D. If the connector diameter is larger than the insulation diameter, apply two half-lapped layers of SRM over the entire connection.

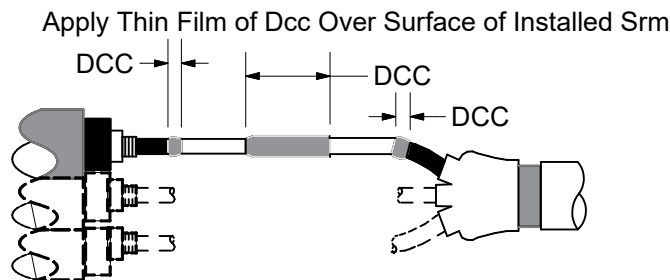


13. APPLY SRM AT BLACK CONDUCTIVE TUBE AND SEMI-CON STEPS, APPLY DISCHARGE CONTROL COMPOUND, AND THEN POSITION BLACK STRESS CONTROL TUBE.

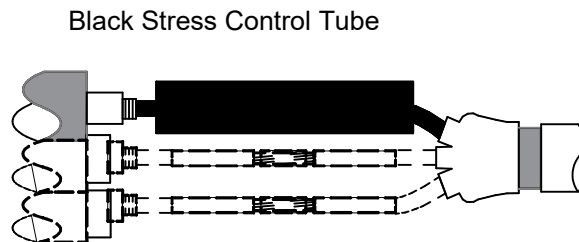
- A. Remove the backing from the short angle-cut piece of SRM. Place the tip of SRM at the black conductive tube step and tightly wrap to fill the step. Overlap black conductive tube and OBT/insulation and taper as shown.
- B. Repeat the above procedure for the semi-con step.



- C. Snip open the end of the DCC tube and apply a thin film of compound on the SRM over the connector and semi-con steps.



- D. Center the black stress control tube over the completed connector area. Be sure to equally overlap the semi-con and the black conductive tube.

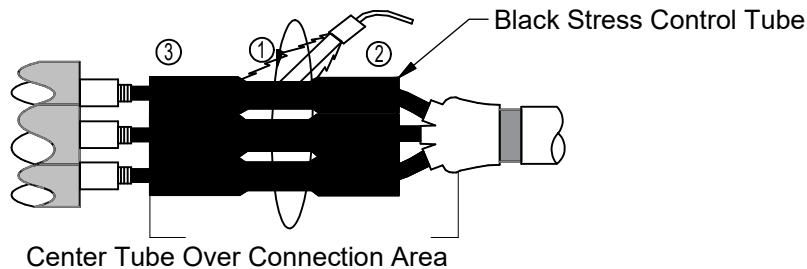




COMPLETE STEPS 12 AND 13 FOR THE REMAINING TWO PHASES BEFORE PROCEEDING TO STEP 14.

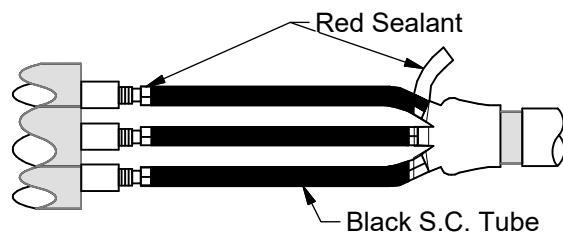
#### 14. SHRINK BLACK STRESS CONTROL TUBES

- A. Make sure that each tube is centered over the connection area, equally overlapping the semi-con and black conductive tube.
- B. Shrink all three tubes in place at the same time.
- C. Begin shrinking at center of tubes (1), working torch with a smooth brushing motion around the tubes.
- D. After center portions shrink, work torch toward one end (2), then to opposite end (3). Post heat all tubes.
- E. Apply sufficient heat to ensure softening of the SRM, indicated by a smooth surface profile.



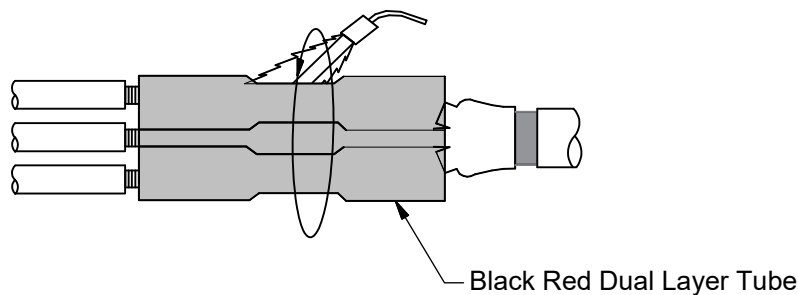
#### 15. APPLY RED SEALANT

- A. Remove backing from red sealant.
- B. Using light tension, wrap sealant over the cable and butt against the black stress control tube as shown.
- C. Build the sealant to the level of the black stress control tube.



#### 16. POSITION AND SHRINK BLACK/RED DUAL LAYER TUBES

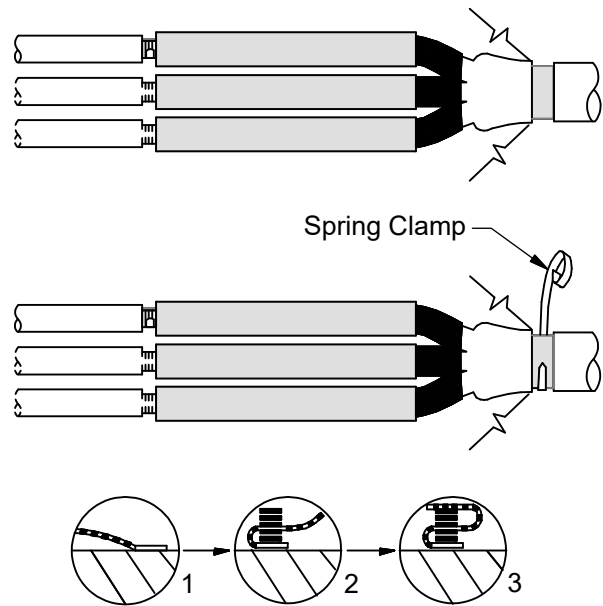
- A. Center the tubes over the black stress control tubes.
- B. Shrink in place using the method described in 14 except stop shrinking 5" from each end. Then shrink each end.
- C. After initial shrinking, heat the entire tubes for approximately 1 minute. The raised ridges should disappear. Absence of ridges can be observed by visual inspection and feeling the surface with gloved hand.



## 17. INSTALL GROUND LEADS TO PILC CABLE

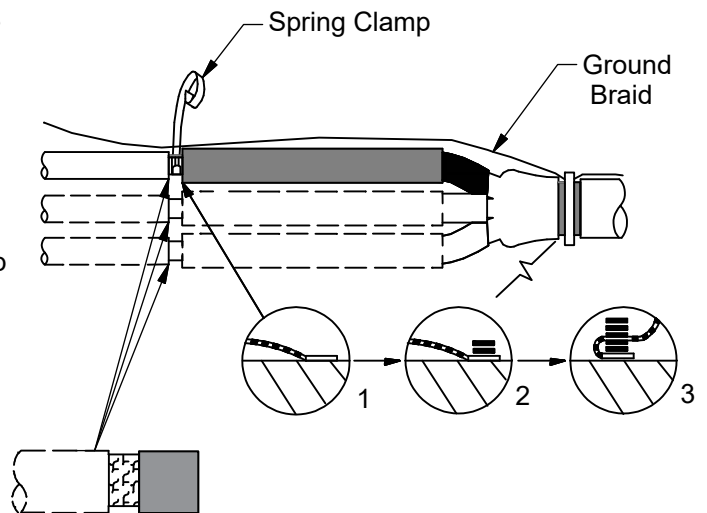
There are three long braids provided with this kit. One end of the braid has a short length of heat shrink tube installed next to a 2" wide solder block. This is the end of the braid which will be positioned over the jacket for external grounding.

- A. Wrap three layers of 2" wide copper mesh around the cleaned lead sheath on the 3/C PILC side of the joint. Tie off with half hitch or equivalent knot.
- B. Lay three braids across the joint evenly spaced around the joint circumference so that the braids overlap the mesh and the solder block is positioned over the jacket and aligned with the cable jacket cutback. Temporarily tape the braids into position.
- C. (1) Wrap two turns of the large spring clamp over the three braids and mesh. (2) Fold the long end of the braid back over the spring clamp and wrap two additional turns. (3) Fold long end one more time the spring clamp and complete wrapping the spring clamp over the braid. (The long end of the braid should be going across the splice at this time.)



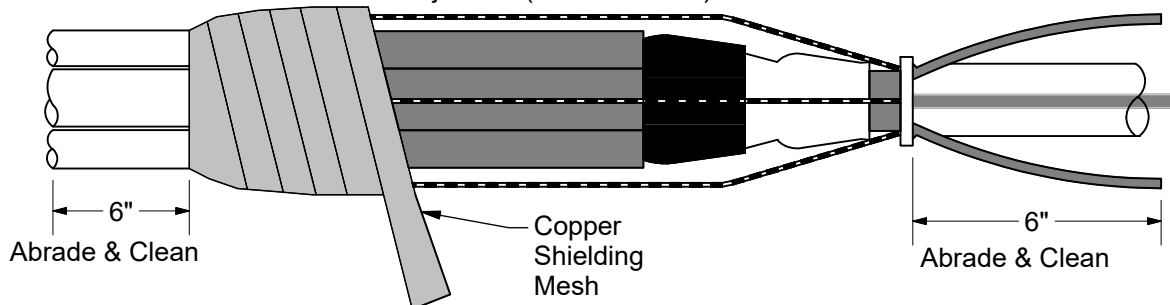
## 18. INSTALL GROUND LEADS TO METALLIC SHIELDS

- A. Wrap three layers of 2" wide copper mesh around the metallic shields of the solid dielectric cable and tie off with a half hitch or equivalent knot. (Wrap around flat strap, concentric wires or LC Shield.)
- B. (1) Lay braid directly over the mesh. (2) Wrap two turns of the small spring clamp over the braid and mesh. (3) Fold back the braid over the spring clamp and complete wrapping the spring clamp over the braid. (Excess braid should be going across the splice at this time.) Excess braid may be cut off or left over the splice.
- C. Repeat this step for remaining phases until all three phases are completed.



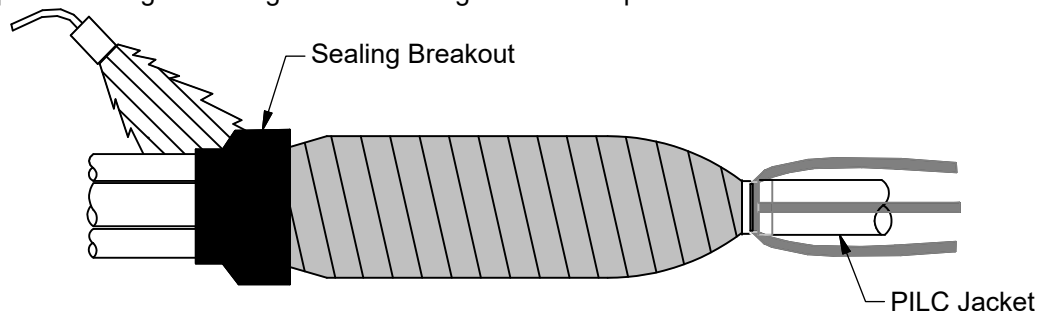
## 19. APPLY SHIELDING MESH

- Starting over the ground connections on the extruded solid dielectric cable side of the splice, wrap one half-lapped layer of 2" wide shielding mesh across the splice and tie off to the PILC cable lead sheath.
- Abrade and solvent clean the cable jackets (or lead sheath) as shown.



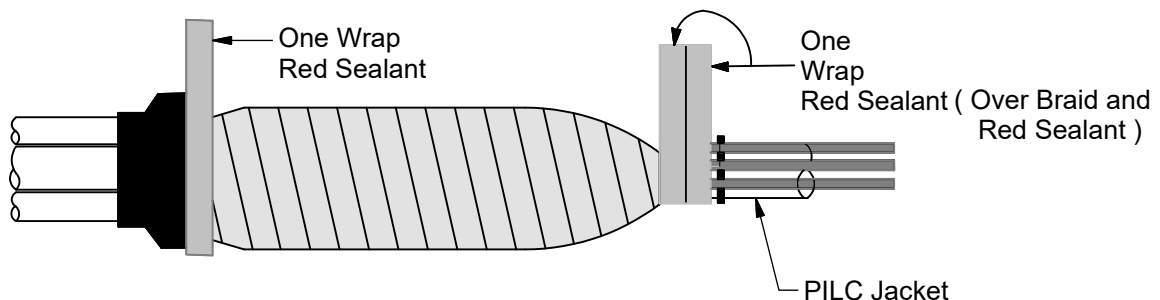
## 20. POSITION AND SHRINK NON-CONDUCTIVE SEALING BREAKOUT

- Slide the breakout into position. Make sure that the full length of the fingers of the breakout are over the cable jackets and the body is extending over the splice.
- Shrink in place starting at the fingers and working toward the splice center.



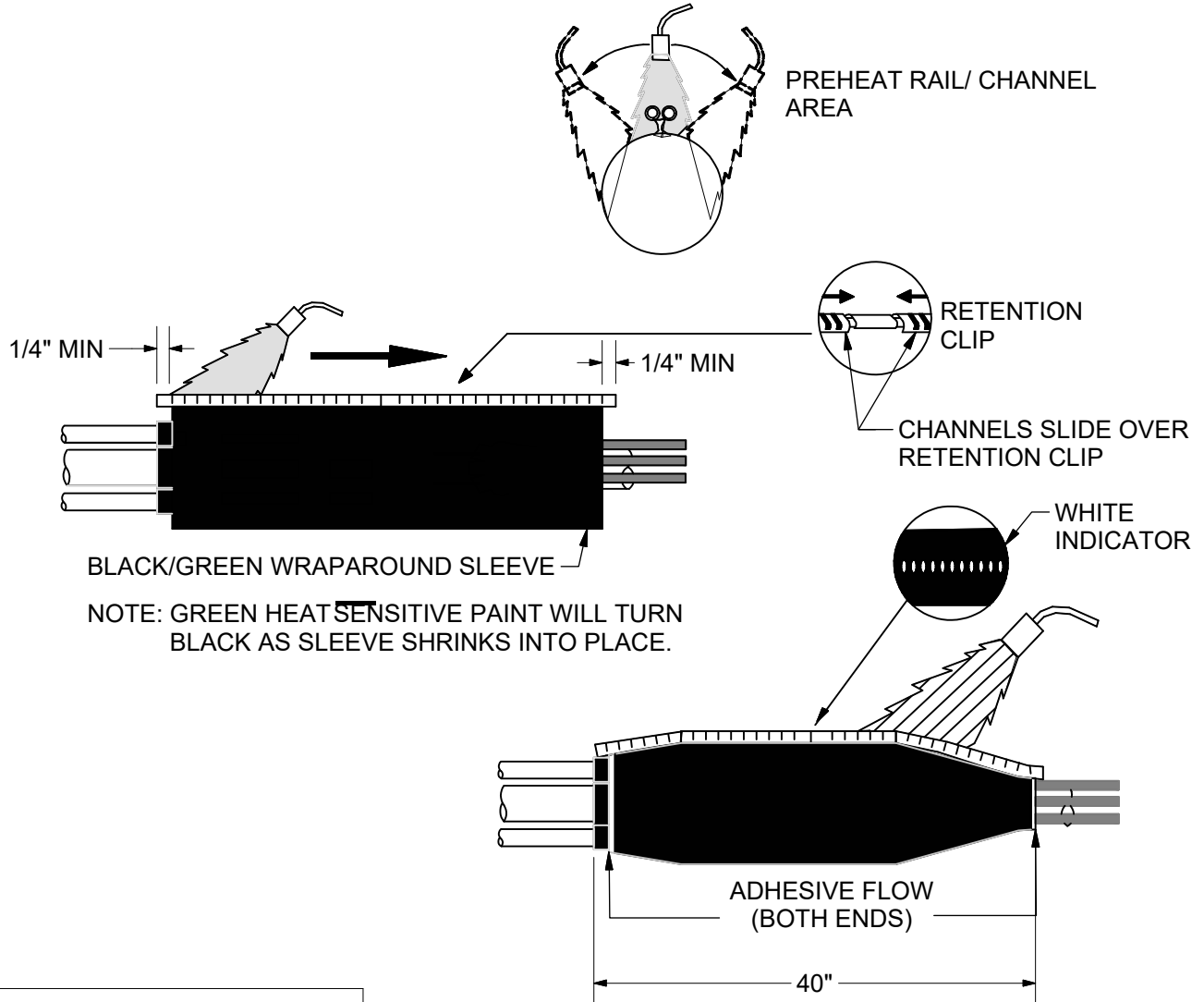
## 21. APPLY RED SEALANT

- Allow the breakout to cool sufficiently to touch before proceeding.
- Apply two single wraps of red sealant under the ground braids on the PILC cable side. Wraps should be side by side and butted up to the cable jacket cutback.
- Lay the braids down and press the solder blocked portion and the end of the heat shrink tubing into the red sealant.
- Apply two additional single wraps of red sealant over the braids and the first layer of red sealant.
- Apply one wrap of red sealant over the body of the breakout as shown.



## 22. POSITION AND SHRINK WRAPAROUND SLEEVE

- A. Remove or tape over all sharp points to prevent puncture of wraparound sleeve.
- B. Remove the backing from the wraparound sleeve and center sleeve over splice.
- C. Slide the metal retention clip onto the butted rails. Connect the channels by overlapping the retention clip as shown below.
- D. Channel(s) must overlap sleeve edges by 1/4" minimum.
- E. Preheat evenly along both sides of the rail/channel area until this area begins to shrink. (Critical Step)
- F. Begin shrinking at the center of the sleeve and work all the way around the sleeve and toward each end.
- G. Apply heat until the sleeve is completely shrunk and the green paint is completely converted to black.
- H. Post heat the entire length, concentrating on the metal channel area. The post heat should be for 30 seconds after the sleeve is completely shrunk. A white line should be visible in the channel gaps indicating sufficient heating.
- I. Look for adhesive flow at both ends of the sleeve.
- J. Allow the sleeve to cool before moving or placing in service.



**The splice is now complete**



# UNDERGROUND CABLE SPLICE

Trifurcating: 3/C PILC to 3-1/C Solid Dielectric  
Heat-Shrinkable

<b>41 33 22 **</b>
<b>15 kV</b>
<b>10 of 10</b>

## Heat Shrink Splice Standards For Common Cable Splices

DCS	PILC CABLE	TO	SOLID DIELECTRIC CABLE
41 33 22 01	1/0 <sup>3</sup>		3 - 1/0 CNRP
41 33 22 02	1/0 <sup>3</sup>		3 - #2 ALCNRP
41 33 22 03	1/0 <sup>3</sup>		3 - 4/0 ALCNRP
41 33 22 04	4/0 <sup>3</sup>		3 - 4/0 ALCNRP
41 33 22 05	350 <sup>3</sup>		3 - 4/0 ALCNRP
41 33 22 06	350 <sup>3</sup>		3 - 350 CNRP
41 33 22 06	350 <sup>3</sup>		3 - 350 FSRP, RW
41 33 22 07	800 <sup>3</sup>		3 - 750 LCRP
41 33 22 07	800 <sup>3</sup>		3 - 750 FSRP, RW
41 33 22 07*	800 <sup>3</sup>		3 - 1000 TSRP

\* 800 kcmil to 1000 kcmil compression sleeve is not included in the standard.

ITEM	STK / DCS #	DESCRIPTION	41 33 22 **	01	02	03	04	05	06	07
A	17 05 308	Splice-Cond., Trif., H.S., 1/0-4/0 AWG		1	1	1	1	-	-	-
	17 05 307	Splice-Cond., Trif., H.S., 350 kcmil		-	-	-	-	1	1	-
	17 05 306	Splice-Cond., Trif., H.S., 750-800 kcmil		-	-	-	-	-	-	1
B	17 60 357	Sleeve-Cmpsn., 1/0 Cu		3	-	-	-	-	-	-
	17 60 344	Sleeve-Cmpsn., 1/0 - #2 Al.		-	3	-	-	-	-	-
	17 63 143	Sleeve-Cmpsn., 1/0 - 4/0 Al.		-	-	3	-	-	-	-
	17 60 317	Sleeve-Cmpsn., 4/0 Al.		-	-	-	3	-	-	-
	17 63 201	Sleeve-Cmpsn., 350 - 4/0 Al.		-	-	-	-	3	-	-
	17 60 359	Sleeve-Cmpsn., 350 kcmil Cu.		-	-	-	-	-	3	-
	17 60 504	Sleeve-Cmpsn., 800 kcmil to 750 kcmil Cu.		-	-	-	-	-	-	3
C	25 53 055	Tape-Plastic ( RL )		1	1	1	1	1	1	1
	729	Op Code Splice 15 kV Heat Shrink		1	1	1	1	1	1	1

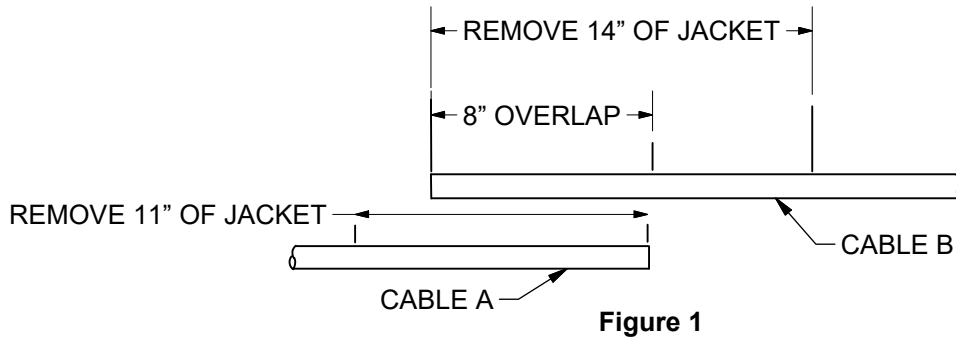
### DISTRIBUTION CONSTRUCTION STANDARDS

REV	DATE	ENG	DESCRIPTION
4	01/01/23	EJB	Converted to New Format
3	08/09/10	EJB	

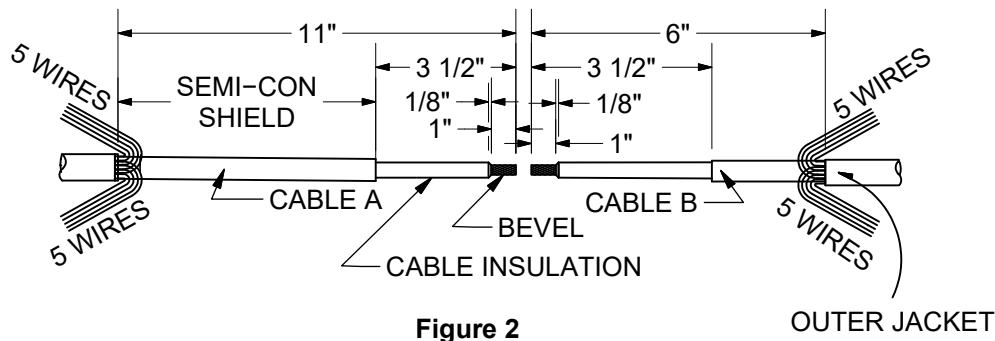
## INSTRUCTIONS - 3M STANDARD SPLICE:

Read the cautionary statement on Sheet 9 before starting.

1. There must be an 8" overlap of the cables, Figure 1. Wipe clean 24" each side.



2. Place the shinkable sleeve on either cable.
3. Remove 14" of jacket Cable B, 11" of jacket Cable A.
4. For single phase cables train the concentric wires in two bundles each side, five wires per bundle. See Figure 2. For three phase cables train concentric wires in one six wire bundle.



5. Cut 8" off Cable B. Cut cables with a hack saw so that the cable ends butt together at the splice center.
6. Strip cables for splicing per Figure 2, clean cables - DO NOT USE SILICONE SPRAY ON CABLES OR SPLICE BODY.
7. Prior to installing the connector, clean the exposed conductor with a stainless steel wire brush. Some splice kits may contain a small disposable stainless steel wire brush, if so, it should be used. If there is no wire brush in the kit, use one of the stocked stainless steel wire brushes.
8. Lubricate insulation and semi-con shield of Cable A with silicone grease. Install splice body onto Cable A, leaving conductor exposed for the connector. Lubricate bore with silicone grease to aid installation.
9. Install the connector, Make as many crimps per end as possible without overlap. File flashing down. Remove excess inhibitor.
10. Lubricate insulation and semi-con shield of Cable B with silicone grease. Slide splice body onto Cable B and into final position over the connector. Use the bumps formed on the splice ends as guides for centering. See Figure 3.

11. Connect concentrics with two sleeves on Side A. For single phase cables, place five wires per side into each sleeve. For three phase cables, place all six wires into one sleeve. Crimp the sleeves. Snug sleeves and wires tightly against splice and cable. See Figure 3.

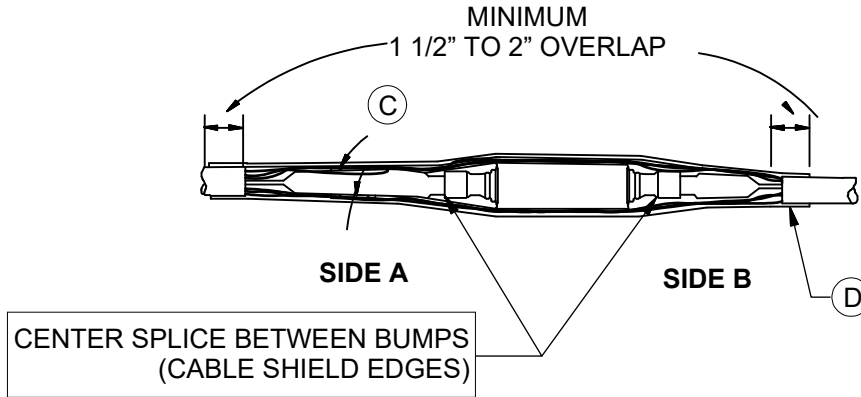


Figure 3

12. Slide shrinkable sleeve over the splice and shrink it down. To install cold-shrinkable sleeves, follow the manufactures' instructions.

CONSTRUCTION NOTE(s):

1. When a cold-shrinkable sleeve or no sleeve is used, connect one or two concentric wires on each end to the ground eyes.
2. When splicing a nonjacketed cable to a long length of jacketed cable seal the jacketed side per DCS # **59 40 90 14**.

## INSTRUCTIONS - ELASTIMOLD STANDARD SPLICE:

Read the cautionary statement on Sheet 9 before starting.

1. There must be an 8" overlap of the cables, Figure 1. Wipe clean 24" each side.

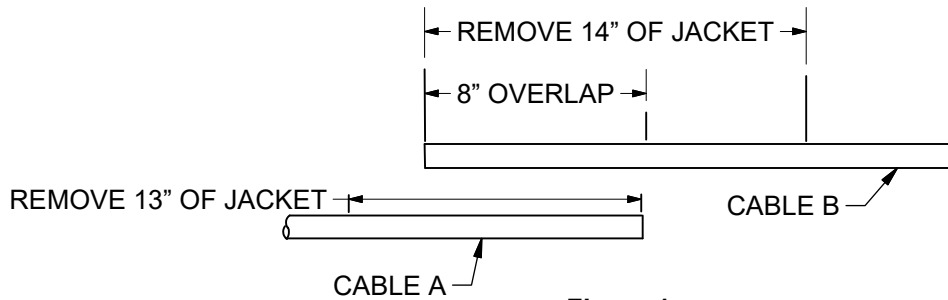


Figure 1

2. Place the shrinkable sleeve on either side.
3. Remove 14" of jacket Cable B, 13" of jacket Cable A.
4. For single phase cables, train the concentric wires in two bundles each side, five wires per bundle. See Figure 2. For three phase cables, train the concentric wires in one six wire bundle.
5. Cut 8" off Cable B. Cut cables with a hacksaw so that the cable end butt together at the splice center.
6. Strip cables for splicing per Figure 2, clean cables - DO NOT USE SILICONE SPRAY ON CABLES OR SPLICE BODY.

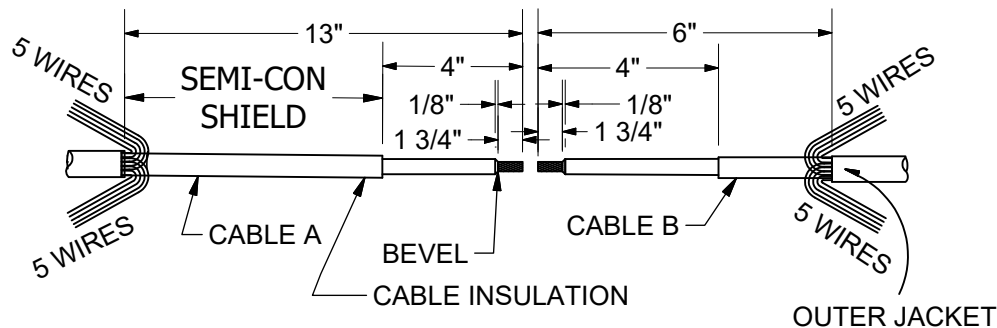
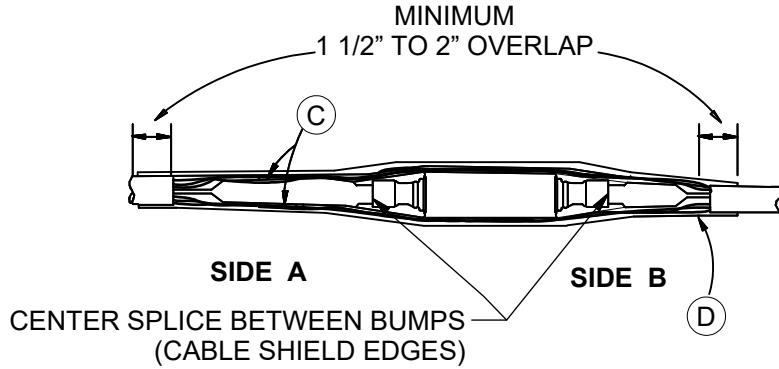


Figure 2

7. Prior to installing the connector, clean the exposed conductor with a stainless steel wire brush. Some splice kits may contain a small disposable stainless steel wire brush, if so, it should be used. If there is no wire brush in the kit, use one of the stocked stainless steel wire brushes.
8. Lubricate insulation and semi-con shield of Cable A with silicone grease. Install splice body onto Cable A, leaving conductor exposed for the connector. Lubricate bore with silicone grease to aid installation.
9. Install the connector. Make as many crimps per end as possible without overlap. File flashing down. Remove excess inhibitor.
10. Lubricate insulation and semi-co shield of Cable B with silicone grease. Slide body onto Cable B and into final position over the connector. Use the bumps formed on the splice ends as guides for centering. See Figure 3.
11. Connect concentrics with two sleeves on Side A. For single phase cables place five wires per side into each sleeve. For three phase cables place all six wires into one sleeve. Crimp the sleeve. Snug sleeves and wires tightly against splice and cable. See Figure 3.



12. Slide shrinkable sleeve over the splice and shrink it down. To install cold-shrinkable sleeves, follow the manufacturers' instructions.



**Figure 3**

**CONSTRUCTION NOTE(s):**

1. When a cold-shrinkable sleeve or no sleeve is used, connect one or two concentric wires on each end to the grounding eyes.
2. When splicing a nonjacketed cable to a long length of jacketed cable seal the jacketed side per DCS # 59 40 90 14.

## INSTRUCTIONS - COOPER STANDARD SPLICE:

Read the cautionary statement on Sheet 9 before starting.

1. There must be an 8" overlap of the cables, Figure 1. Wipe clean 24" each side.

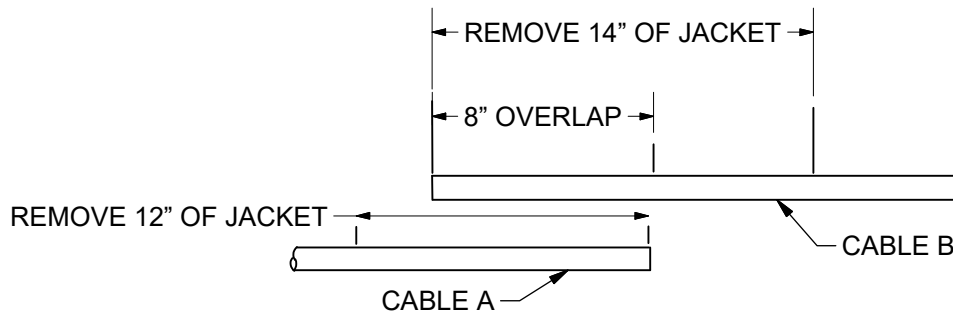


Figure 1

2. Place the shrinkable sleeve on either cable.
3. Remove 14" of jacket Cable B, 12" of jacket Cable A.
4. For single phase cables train the concentric wires in two bundles each side, five wires per bundle. See Figure 2. For three phase cables train concentric wires in one six wire bundle.
5. Cut 8" off Cable B. Cut cables with a hack saw so that the cable ends butt together at the splice center.
6. Strip cables for splicing per Figure 2, clean cables - DO NOT USE SILICONE SPRAY ON CABLES OR SPLICE BODY. Prior to installing the conector, clean the exposed conductor with a stainless steel wire brush. Some splice kits may contain a small disposable stainless steel wire brush, if so, it should be used. If there is no wire brush in the kit, use one of the stocked stainless steel brushes.

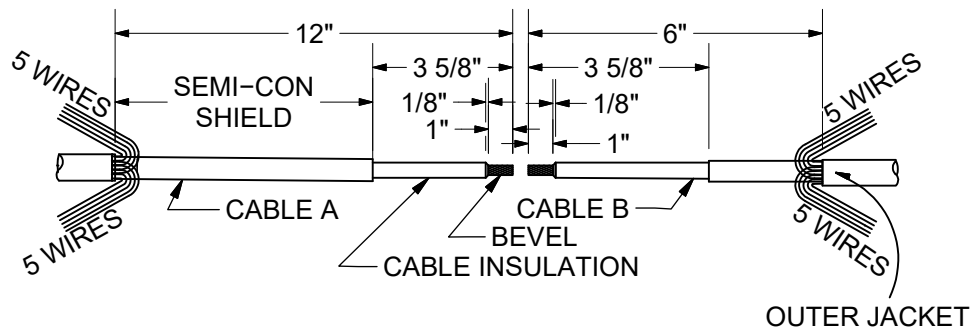
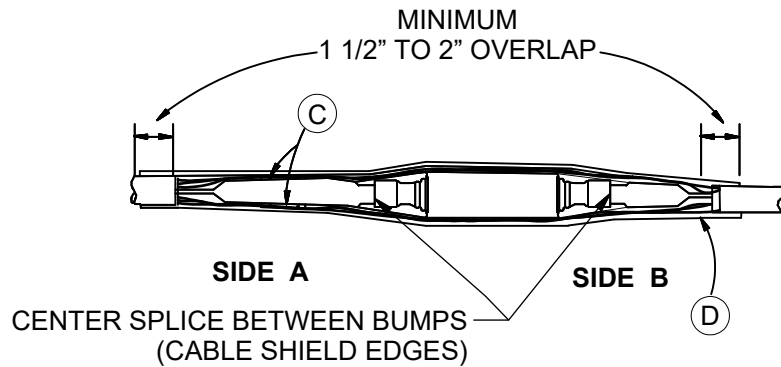


Figure 2

7. Lubricate insulation and semi-con shield of Cable A with silicone grease. Apply one wrap of tape to the end of the conductor on Cable A. Install splice body onto Cable A, leaving conductor exposed for the connector. Lubricate bore with silicone grease to aid installation.
8. Remove tape from the conductor on Cable A. Clean bare conductors with a wire brush prior to installing the connector.
9. Install the connector. Make as many crimps per end as possible without overlap. Leave the center 1/4" of the connector uncrimped. File flashing down. Remove excess inhibitor.
10. Lubricate insulation and semi-con shield of Cable B with silicone grease. Slide splice body onto Cable B and into final position over the connector. Use the bumps formed on the splice ends as guides for centering. See Figure 3.

11. Connect concentrics with two sleeves on Side A. Place five wires per side into each sleeve. Crimp the sleeves. Snug sleeves and wires tightly against splice and cable. See Figure 3.



**Figure 3**

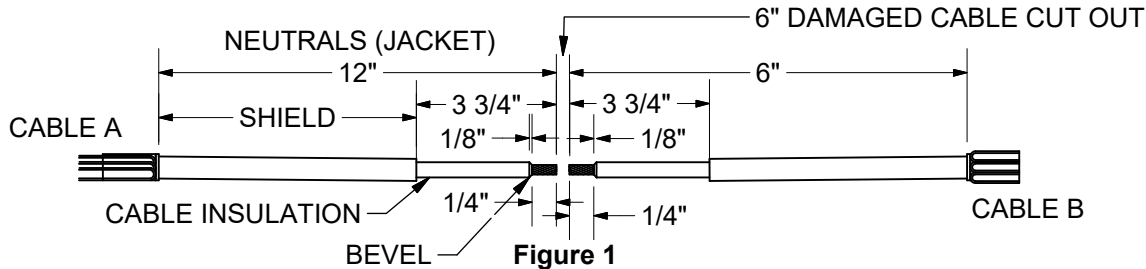
12. Slide shrinkable sleeve over the splice and shrink it down. To install cold-shrinkable sleeves, follow the manufacturers' instructions.

**CONSTRUCTION NOTE(s):**

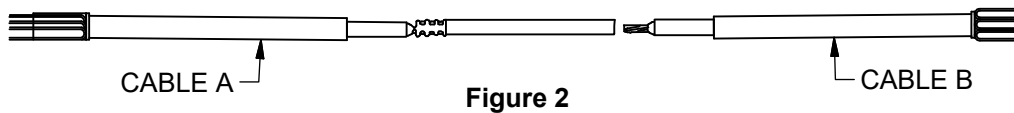
1. When a cold-shrinkable sleeve or no sleeve is used, connect one or two concentric wires on each end to the grounding eyes.
2. When splicing a nonjacketed cable to a long length of jacketed cable, seal the jacketed side per DCS # 59 40 90 14.

## INSTRUCTIONS -3M LONG REPAIR SPLICE:

1. Cut out damaged cable section, do not exceed 6". Retain neutral wires from damaged section. Use a hack saw to get clean cuts.
2. Prepare cables as shown in Figure 1. If cable is jacketed, remove jacket to expose neutral wires. For single phase cables train the concentric wires in two bundles each. For three phase cables train the concentric wires in one six wire bundle. Place the shrinkable sleeve on one of the cables.



3. Fold neutrals back and clean dirt off of the semi-con shield and the insulation. Use a dry cloth. Prior to installing the connector, clean the exposed conductor with a stainless steel wire brush. Some splice kits may contain a small disposable stainless steel wire brush, if so, it should be used. If there is no wire brush in the kit use one of the stocked stainless steel brushes.
4. Install the connector on Cable A only and crimp. Wipe off excess inhibitor and file flashing down.



5. Lubricate connector, insulation, semi-con, and splice bore with silicone grease. Install splice body onto connector and Cable A until uncrimped connector end is exposed approximately 2". **DO NOT USE SPRAY SILICONE.**
6. Install Cable B into connector and crimp. Clean off excess inhibitor and file flashing down.
7. Lubricate insulation and semi-con of Cable B and the exposed connector and bore area of the splice body with silicone grease. Slide splice body only onto Cable B. Use bumps formed on splice ends as guides for centering.
8. Tape down concentric strands at ends of splice.
9. Attach one concentric from cable through its splice grounding eye and back to the concentric neutral wires. (Cold-shrinkable sleeve and Non-jacketed cables only.)
10. Twist the strands together and jumper across the splice using cable neutral wires and retained neutral wires. For single phase cables connect each bundle using two sleeves. See Figure 3. For three phase cables connect the bundle using one sleeve. Make sure that the neutral wires are against the splice body.

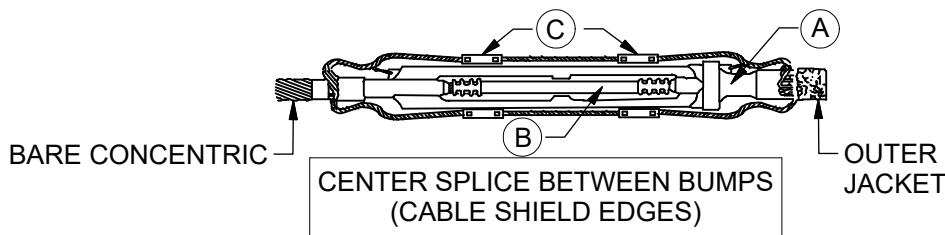


Figure 3

## CONSTRUCTION NOTE(s):

1. Slide shrinkable sleeve over splice and shrink down.
2. When splicing a non jacketed cable to a long length of jacketed cable, seal the jacketed side per DCS # 59 40 90 14.



# UNDERGROUND CABLE SPLICE

Premolded  
#2 Al and 1/0 Al CNX/CNR

<b>41 34 34 **</b>
<b>15kV</b>
<b>8 of 9</b>

DCS #	DESCRIPTION
41 34 34 05	1/0 Al Stranded
41 34 34 07	#2 Al Solid
41 34 34 08	Transition #2 Solid to 1/0 Stranded AL
41 34 34 09	Transition #2 Stranded to 1/0 Stranded AL
41 34 34 10	Transition #2 Stranded to #2 Solid Al, or #4 Stranded Cu
41 34 34 11	#2 Al Stranded
41 34 34 14	Long Repair #2 Al, Solid or #4 Stranded Cu
41 34 34 15	Long Repair #1/0 Stranded
41 34 34 16	Long Repair #2 Al, Stranded

ITEM	STK / DCS #	DESCRIPTION	41	34	34	**	05	07	08	09	10	11	14	15	16
A	17 55 283	Splice – #2 Al Str. 15kV	1	1	1	1	1	1	1	1	1	1	-	-	-
	17 55 288	Splice – Long Repair, #2 Al. Str. 15kV	-	-	-	-	-	-	-	-	-	-	1	-	1
	17 62 250	Splice – Long Repair, 1/0 Al Str. 15kV	-	-	-	-	-	-	-	-	-	-	-	1	-
B	17 60 506	Sleeve – #2 Solid Al	-	1	-	-	-	-	-	-	-	-	-	-	-
	17 60 505	Sleeve – 1/0 Str. Al	1	-	-	-	-	-	-	-	-	-	-	-	-
	17 60 501	Sleeve – Transition #2 Str. to #2 Solid Al, or #4Cu Str	-	-	-	-	-	-	-	1	-	-	-	-	-
	17 60 502	Sleeve – Transition #2 Str. to 1/0 Str. Al	-	-	-	-	1	-	-	-	-	-	-	-	-
	17 60 408	Sleeve – Transition #2 Solid to 1/0 Str. Al	-	-	1	-	-	-	-	-	-	-	-	-	-
	17 60 409	Sleeve – Long Repair, #2 Al, Solid, or #4 Str. Cu, 15kV	-	-	-	-	-	-	-	-	-	-	1	-	-
C	17 60 103	Sleeve – #4 Str. Cu.	2	2	2	2	2	2	2	2	2	4	4	4	
D	17 55 371	Sleeve Cold-Shrinkable	1	1	1	1	1	1	1	1	1	1	1	1	1
	404	Op Code Splice #2 AL. Str. 15 kV	1	1	1	1	1	1	1	1	1	1	1	1	1

REV	DATE	ENG	DESCRIPTION
10	01/01/23	EJB	Converted to new format
9	02/10/14	EJB	



# UNDERGROUND CABLE SPLICE

Premolded  
#2 Al and 1/0 Al CNX/CNR

41 34 34 **
15kV
9 of 9

## CAUTIONARY STATEMENT

The standard splice (Stock. #17 55 283) is for #2 stranded aluminum cables (Stock. #18 07 238 and Stock. #18 07 237). If any cables other than the standard #2 stranded aluminum cables are to be spliced together, the compression sleeve in the standard splice must be discarded and replaced by one of the compression sleeves shown in the materials list.

DO NOT CHANGE THE CABLE PREPARATION DIMENSIONS SHOWN FOR EACH APPROVED SUPPLIER'S SPLICE WHEN SUBSTITUTING A COMPRESSION SLEEVE FOR THE STANDARD #2 COMPRESSION SLEEVE. THIS IS ESPECIALLY IMPORTANT WHEN SUBSTITUTING A 2" LONG COMPRESSION SLEEVE FOR THE 3" LONG COMPRESSION SLEEVE IN THE ELASTIMOLD SPLICE. IF THE DIMENSIONAL REQUIREMENTS SHOWN ARE NOT MAINTAINED - THE SPLICE WILL FAIL.

REV	DATE	ENG	DESCRIPTION
10	01/01/23	EJB	Converted to new format
9	02/10/14	EJB	

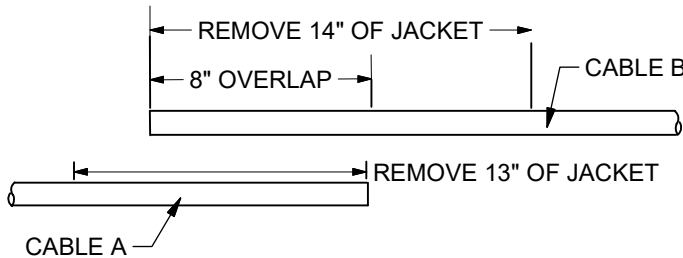


Figure 1

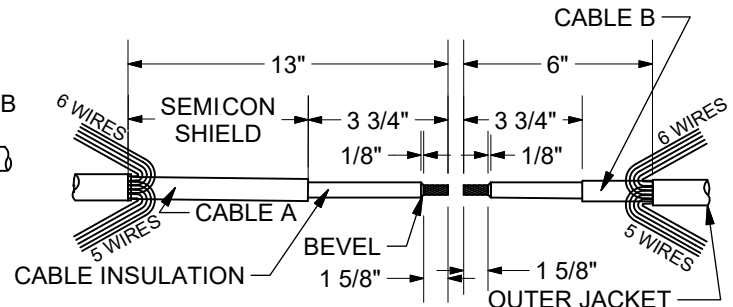


Figure 2

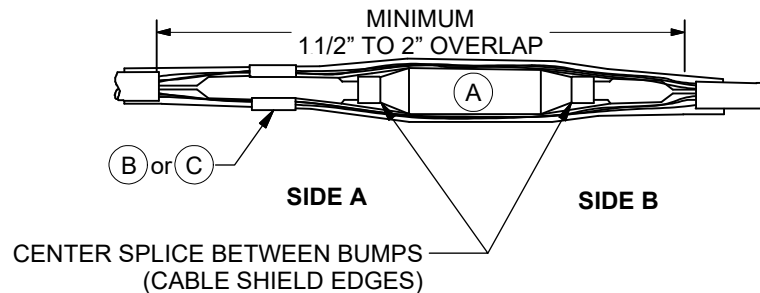


Figure 3

INSTRUCTIONS - 3M CABLE SPLICE:

1. There must be an 8" overlap of the cables. See Figure 1. Wipe clean 24" on each side.
2. Remove 14" of jacket from Cable B, 13" of jacket from Cable A.
3. Place the shrinkable sleeve(s) on either side.
4. Train the concentric wires in two bundles each side, five and six wires per bundle. See Figure 2.
5. Cut 8" off Cable B. Cut cables with a hawksaw so that the cable ends butt together at the splice center.
6. Strip cables for splicing per Figure 2, clean cables - **DO NOT USE SILICONE SPRAY ON CABLE OR JOINT.**
7. Clean the bare conductors with a stainless steel wire brush prior to installing the connector. Some splice kits may contain a small disposable stainless steel wire brush, if so, it should be used. If there is no wire brush in the kit, use one of the stocked stainless steel wire brushes.
8. Lubricate insulation and semi-con shield of Cable A with silicone grease. Install splice body onto Cable A, leaving conductor exposed for the connector. Lubricate bore with silicone grease to aid installation.
9. Install the connector. File the flashing down.
10. Lubricate insulation and semi-con shield of Cable B with silicone grease. Slide splice body onto Cable B and into final position over the connector. Use the bumps formed on the splice ends as guides for centering. See Figure 3.
11. Connect concentric with two sleeves on Side A. Place five and six wire bundles into connectors. Crimp the sleeves. Snug sleeves and wires tightly against splice and cable. See Figure 3. The 4/0 single phase cable with twenty #12 concentrics requires three wire bundles and three #2 sleeves.
12. For the cold shrink sleeve, place a layer of mastic around the end of each cable jacket. Slide the first cold shrink sleeve over the splice with the end of the sleeve overlapping the opposite cable jacket cut off (or mastic strip) by 2". Shrink the sleeve down. Wrap one layer of mastic tape at the inner end of the shrunken sleeve. Slide the second sleeve over the splice and overlap the first sleeve by 2". Shrink the second sleeve down.

CONSTRUCTION NOTE(s):

1. For cold shrink sleeves or no re-jacketing sleeves, connect one or two concentric wires on each end to the grounding eyes.
2. When splicing a non-jacketed cable to a long length of jacketed cable seal the jacketed side per DCS 59 40 90 14.
3. When splicing in manholes an external ground connection is required - see sheet 3 for instructions.

REV	DATE	ENG	DESCRIPTION
11	01/01/23	EJB	Converted to new format
10	06/02/14	EJB	

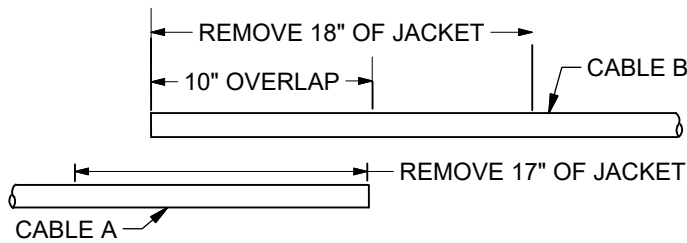


Figure 1

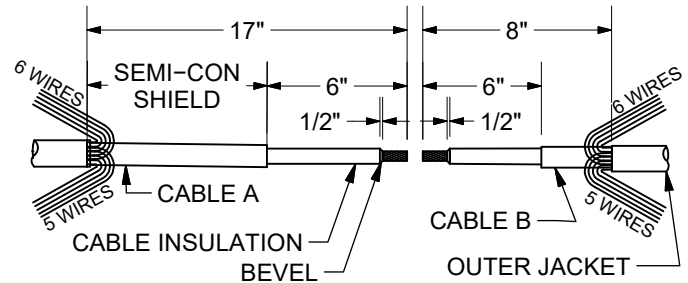


Figure 2

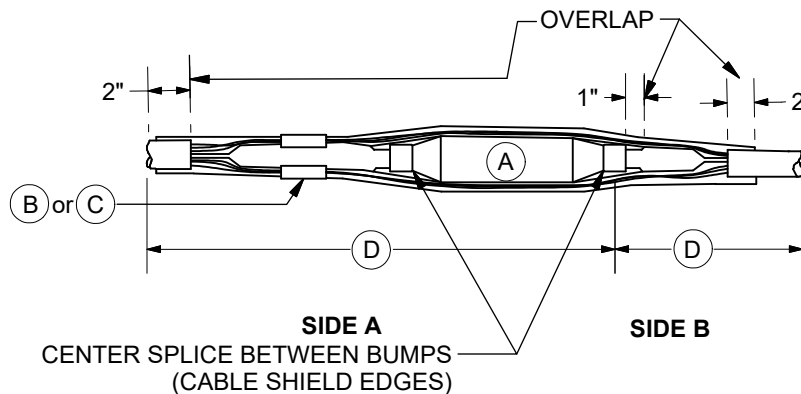


Figure 3

## INSTRUCTIONS - ELASTIMOLD CABLE SPLICE:

1. There must be an 10" overlap of the cables. Figure 1. Wipe clean 24" on each side.
2. Remove 18" of jacket from Cable B, 17" of jacket from Cable A.
3. Place the shrinkable sleeves on either side of the cable.
4. Train the concentric wires in two bundles each side, five and six wires per bundle. See Figure 2.
5. Cut 10" off Cable B. Cut cables with a hawksaw so that the cable ends butt together at the splice center.
6. Strip cables for splicing per Figure 2, clean cables - **DO NOT USE SILICONE SPRAY ON CABLE OR JOINT.**
7. Clean the bare conductors with a stainless steel wire brush prior to installing the connector. Some splice kits may contain a small disposable stainless steel wire brush, if so, it should be used. If there is no wire brush in the kit, use one of the stocked stainless steel wire brushes.
8. Lubricate insulation and semi-con shield of Cable A with silicone grease. Install splice body onto Cable A, leaving conductor exposed for the connector. Lubricate bore with silicone grease to aid installation.
9. Install the connector. File the flashing down.
10. Lubricate insulation and semi-con shield of Cable B with silicone grease. Slide splice body onto Cable B and into final position over the connector. Use the bumps formed on the splice ends as guides for centering. See Figure 3.
11. Connect concentric with two sleeves on Side A. Place five and six wire bundles into connectors. Crimp the sleeves. Snug sleeves and wires tightly against splice and cable. See Figure 3. The 4/0 single phase cable with twenty #12 concentrics requires three wire bundles and three #2 sleeves.
12. For the cold shrink sleeve, place a layer of mastic around the end of each cable jacket. Slide the first cold shrink sleeve over the splice with the end of the sleeve overlapping the opposite cable jacket cut off (or mastic strip) by 2". Shrink the sleeve down.  
Wrap one layer of mastic tape at the inner end of the shrunken sleeve. Slide the second sleeve over the splice and overlap the first sleeve by 2". Shrink the second sleeve down.

## CONSTRUCTION NOTE(S):

1. For cold shrink sleeves or no re-jacketing sleeves, connect one or two concentric wires on each end to the grounding eyes.
2. When splicing a non-jacketed cable to a long length of jacketed cable seal the jacketed side per DCS 59 40 90 14.
3. When splicing in manholes an external ground connection is required - see sheet 3 for instructions.





# UNDERGROUND CABLE SPLICE

Premolded  
4/0 Al CNX/CNR

<b>41 34 35 **</b>
<b>15kV</b>
<b>3 of 3</b>

**INSTRUCTIONS - GROUND CONNECTION FOR SPLICES INSTALLED IN MANHOLES (DCS 41 34 35 08 & 41 34 35 09):**

1. Prior to installing the cold shrink sleeves, wrap six layers of shielding.
2. Attach a ground braid and a constant force spring over the shielding braid on Cable A. Install the ground braid and spring per DCS **59 40 93 44**. Wrap two layers of plastic tape over the spring connector (no sealer is needed as shown in the standard). Position the tails of the ground braid away from the splice body.
3. Apply two mastic strips from the cold shrink jacket kit at the end of the cable jacket cutoffs on each cable. Wrap one layer of mastic at each cutoff. Apply the mastic over the ground braid on Cable A.
4. Slide the first cold shrink sleeve over the splice with the end of the sleeve overlapping the opposite cable jacket cutoff (or mastic strip) by 2". Shrink the sleeve down.
5. Wrap one layer of mastic at the inner end of the shrunken sleeve.
6. Slide the second sleeve over the splice and overlap the first cold shrink sleeve by 1/2" minimum. Shrink the second sleeve down.
7. Attach the ground braid tails to a piece of #2 Cu bond wire using a two bolt clamp (Stock #17 54 140). Seal the two bolt connector, the bond wire, and the ground braid connections using sealer compound (Stock #31 53 055) and two layers of plastic tape (Stock #25 53 055) wrapped over the outside. Connect the #2 Cu bond wire to the 4/0 Cu bond wire in the manhole (system ground) using a two bolt clamp.

DCS #	Description
41 34 35 03	4/0, 3 Phase
41 34 35 05	4/0, 1 Phase
41 34 35 06	3/0 to 4/0 AL, 3 Phase
41 34 35 07	3/0 to 4/0, 1 Phase
41 34 35 08	4/0 AL, 3 Phase with External Ground (Manholes)
41 34 35 09	4/0 AL, 1 Phase with External Ground (Manholes)

ITEM	STK / DCS #	DESCRIPTION	41 34 35 **	03	05	06	07	08	09
A	17 55 285	Splice, Straight, 4/0 Al., 15 kV		1	1	1	1	1	1
B	17 63 127	Sleeve, Compression, # 2 Copper		-	3	-	3	-	3
C	17 60 103	Sleeve, Compression, # 4 Copper		2	-	2	-	2	-
D	17 55 443	Sleeve, Cold Shrinkable		1	1	1	1	1	1
E	17 60 720	Sleeve, Transition, 3/0 to 4/0 Al.		-	-	1	1	-	-
F	17 54 306	Connector - Cable Ground w/ Constant Force Spring		-	-	-	-	1	1
G	18 66 101	Braid - Copper, 1" x 15'		-	-	-	-	1	1
H	17 54 140	Connector - Wire, #8-4/0 Cu, 2 Bolt		-	-	-	-	2	2
	415	Op Code Splice 4/0 AL or CU Str. 15 kV		1	1	1	1	1	1

**CAUTIONARY STATEMENT FOR 3/0 TO 4/0 SPLICING**

The standard splice (Stk. #17 55 285) is for 4/0 stranded aluminum cables (Stk. #18 07 240 and Stk. #18 07 239). If any cables other than the standard 4/0 stranded aluminum cables are to be spliced together, the compression sleeve in the standard splice must be discarded and replaced by the transition sleeve shown in the materials list.

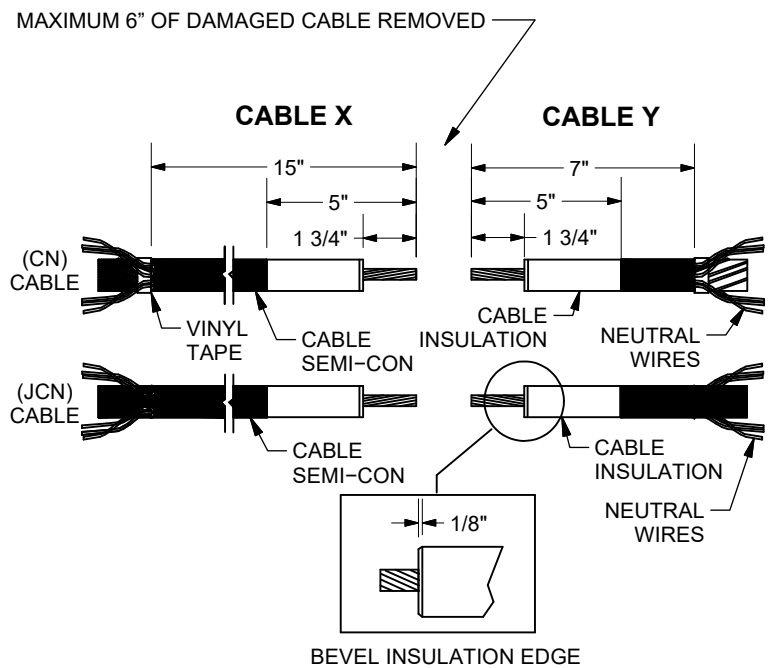
DO NOT CHANGE THE CABLE PERPARATION DIMENSIONS SHOWN FOR EACH APPROVED SUPPLIER'S SPLICE WHEN SUBSTITUTING A COMPRESSION SLEEVE FOR THE STANDARD 4/0 COMPRESSION SLEEVE. THIS IS ESPECIALLY IMPORTANT WHEN SUBSTITUTING A 2" LONG COMPRESSION SLEEVE FOR THE 3" LONG COMPRESSION SLEEVE IN THE ELASTIMOLD SPLICE. IF THE DIMENSIONAL REQUIREMENTS SHOWN ARE NOT MAINTAINED - THE SPLICE WILL FAIL.

**DISTRIBUTION  
CONSTRUCTION STANDARDS**

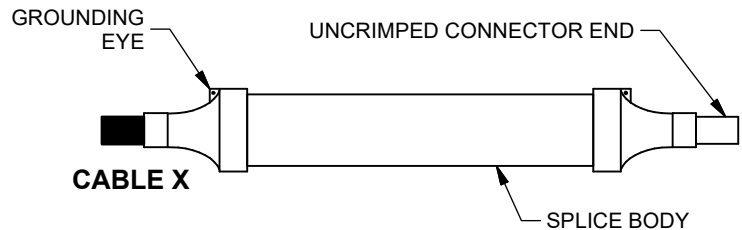
REV	DATE	ENG	DESCRIPTION
11	01/01/23	EJB	Converted to new format
10	06/02/14	EJB	

**INSTRUCTIONS:**

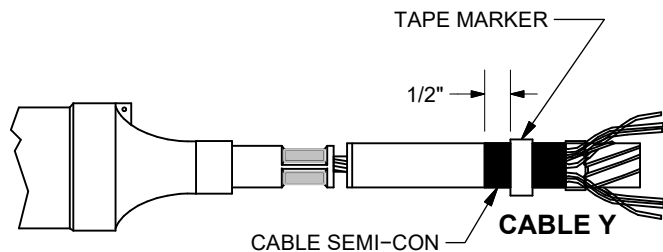
1. Cut out the damaged section of cable, but do not exceed 6". Retain the neutral wires from the damaged section. Use a hacksaw to get a clean square cut.
2. Prepare the cables as shown in Figure 1. If the cable is non-jacketed, bind the neutrals with wire or vinyl tape at the jacket cut back dimensions shown in Figure 1. Check the dimensions using templates provided.
3. Prior to installing the connector, clean the exposed conductor with a stainless steel wire brush. Some splice kits may contain a small disposable stainless steel wire brush, if so, it should be used. If there is no wire brush in the kit, use one of the stocked stainless steel wire brushes.
4. Install the connector onto the "X" cable only. Wipe off excess inhibitor and file sharp flashing.
5. Lubricate the connector, cable "X", and both ends of splice body with the silicone grease provided or Stock #31 51 050.
6. Slide the splice body onto connector and cable "X" until the uncrimped connector end is exposed. See Figure 2.
7. If jacketed cable is being repaired, store the cold-shrinkable sleeves on the cables at this time.
8. Connect the exposed connector end to cable "Y". Wipe off excess inhibitor and file sharp flashing.
9. Place a tape marker on cable "Y" semi-con, 1/2" from the end of the cable semi-con. See Figure 3.
10. Lubricate the expose connector and cable "Y" with silicone grease.
11. Center splice body over the connector so that the leading edge aligns with the marker tape. Remove the marker tape.



**Figure 1**



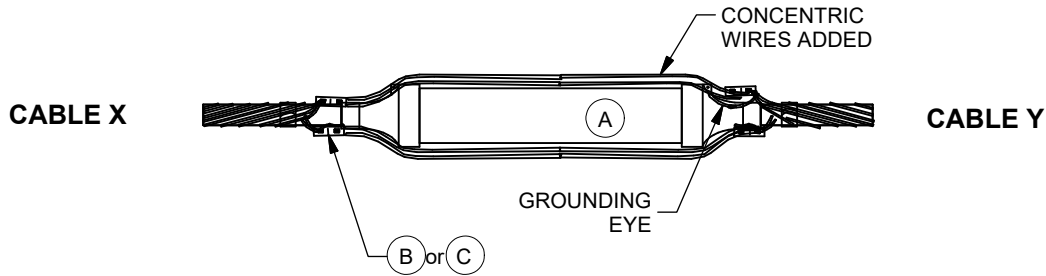
**Figure 2**



**Figure 3**

REV	DATE	ENG	DESCRIPTION
6	01/01/23	EJB	Converted to new format
5	09/16/10	EJB	

12. Connect the concentric neutral wires back over the cable and splice body as follows: for the 4/0 cable with 11 #14 AWG concentric wires (3 ph) make two bundles of wires (one with five wires and one with six wires) and place them into the #4 copper sleeves. Crimp the sleeves. For the 4/0 cable with twenty #12 AWG concentric wires, (1 ph), make three bundles of wires (two with seven wires and one with six wires), and place them into the #2 copper sleeves. Crimp the sleeves. It may be necessary to add concentric wires in order to jumper across the splice. See Figure 4. Make sure that the neutral wires are against the splice body. Connect one concentric wire on each side to its respective grounding eye and return it back to the wire bundle.



**Figure 4**

13. If cold shrinkable covers are used, place a layer of mastic around the end of each cable jacket. Slide the first cold shrink sleeve over the splice with the end of the sleeve overlapping the opposite cable jacket cut off (or mastic strip) by 2". Shrink the sleeve down. Wrap one layer of mastic at the inner end of shrunken sleeve. Slide the second sleeve and overlap the first sleeve by at least 2". Shrink the second sleeve down.
14. When splicing a non-jacketed cable to a jacketed cable or whenever jacketed cables are joined and shrinkable covers are not used, the jackets must be sealed per DCS **59 40 90 14**.

**CONSTRUCTION NOTE(s):**

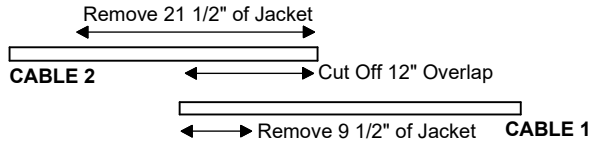
1. Bare concentric cable shown. It could be jacketed or a combination of jacketed and non-jacketed cables.

DCS#	Description
41 34 36 03	4/0, 1 Phase
41 34 36 04	4/0, 3 Phase

	ITEM	STK / DCS #	DESCRIPTION	<b>41 34 36 **</b>	03	04
@	A	17 55 298	Splice - Long Repair Unit, 4/0 Al. 15 kV		1	1
	B	17 63 127	Sleeve - #2 Copper		6	-
	C	17 60 103	Sleeve - #4 Copper		-	4
	D	17 55 443	Sleeve - Cold Shrinkable		1	1
		415	Op Code Splice 4/0 AL or CU Str. 15 kV		1	1

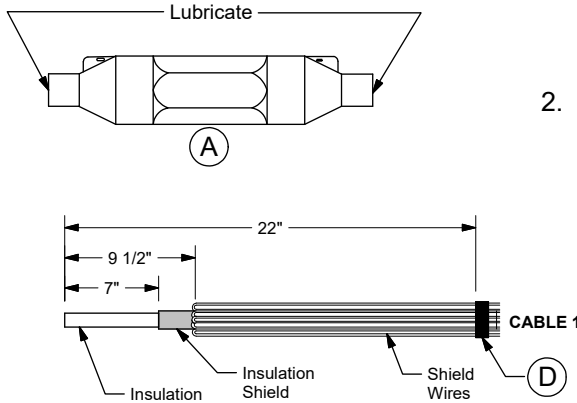
## INSTRUCTIONS:

### 1. Overlap Cables and Remove Cable Jackets



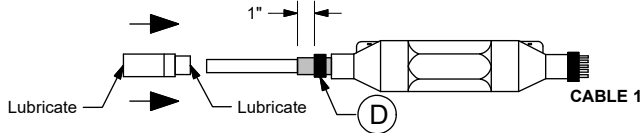
- A. Have Cable 2 overlap Cable 1 by 12". Wipe each cable clean for 36".
- B. Remove 21-1/2" of Cable 2 jacket and 9-1/2" of Cable 1 jacket. Cut 12" of cable off Cable 2.

### 2. Install the Housing



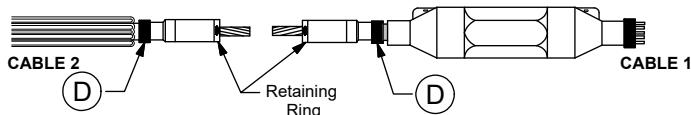
- A. Fold back the wire shields and tape the ends of the wires on Cable 1 to the jacket. Allow enough extra wire to reconnect over the splice.
- B. On each cable, clean the surface of the insulation shield, shield wires, and jacket for a distance of 22". Lubricate the inside of the splice on both ends. Slide onto Cable 1 to a distance of 9-1/2". Carefully remove the insulation shield 7" from both cables. Do Not Cut or Nick the Insulation.

### 3. Prepare the Cable / Install the Adapter



- A. Wrap two turns of tape 1" from the edge of the insulation shield as a marker on both cables.
- B. Clean the cable insulation. Lubricate in the direction of the arrows to provide a build-up or ramp of lubricant at the edge of the insulation shield.
- C. Lubricate the inside of both ends of the cable adapter and install until it meets near end of the tape as shown. Repeat for the second cable adapter.

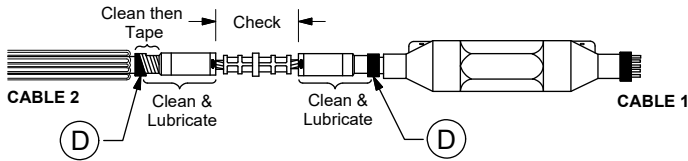
### 4. Install the Retaining Rings



- A. Bare the conductor of each cable flush with the edge of the cable adapters. Do Not Cut or Nick the Conductor.
- B. Slide the retaining ring onto the conductor of Cable 1 up to the cable adapter. Tighten the screws until the retaining ring is firmly secured to the conductor.
- C. Install the second retaining ring on Cable 2 as described above

## 5. Install the Splice

- A. For cable re-jacketing, slide the cold shrink sleeves over Cable 2 and park them for use in Step 6.
- B. Thoroughly clean the end of the cable adapter and Cable 2. Wrap several turns of electrical tape from the adapter to the cable as shown to hold the adapter in place during final assembly.
- C. Wire brush the exposed conductors of both cables and immediately insert into the splicing sleeve. Confirm that the "Check" dimension does not exceed 5-1/8"; otherwise, redo the assembly.
- D. Crimp the splicing sleeve.
- E. Wipe off all excess inhibitor. Confirm that the distance between the cable adapters does not exceed 5-3/8"; otherwise, redo the assembly.
- F. Clean and lubricate the outside surface of the cable adapters before sliding the housing into final position.



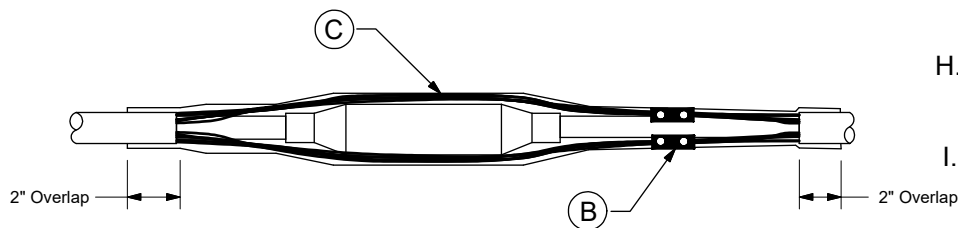
## 6. Complete the Splice Assembly

- A. Slide the housing into final position, centering it over the cable adapters.
- B. Remove all tape. The cable and cable adapter insulation must not be exposed after positioning the splice.
- C. Reshape the shield wires.



## 7. Connect the Concentric Neutral Wires

- A. Use two shear bolt connectors for single phase cables and one shear bolt connector for three phase cables.
- B. Apply inhibitor inside of the connector (s).
- C. Back out the bolts for clearance but do not completely remove them.
- D. For single phase cables divide up the neutral strands between the two connectors.
- E. Insert the neutral strands through each side of the connector to the other end but not sticking out.
- F. Cut off excess length of neutral wires.
- G. Tuck the connector(s) against the splice body.
- H. Hand tighten the bolts to firmly grip the neutral strands in place.
- I. Hold the connector body with a pliers and use a cordless impact wrench or socket wrench to tighten the bolts until they shear off.
- J. Smooth off any sharp edges, clean the connector and apply a wrap of plastic tape over the connector(s).





# UNDERGROUND CABLE SPLICE

Premolded CNX/CNR  
#2 AL CNX/CNR to 4/0 AL

<b>41 34 40 **</b>
<b>15 kV</b>
<b>4 of 4</b>

8. Cover Splice and Jacket Ends with Cold Shrink Sleeve
  - A. Place a layer of mastic around the end of each cable jacket.
  - B. Slide the first cold shrink sleeve over the splice with the end of the sleeve overlapping the opposite cable jacket cut off (or mastic strip) by 2". Shrink the sleeve down.
  - C. Wrap one layer of mastic at the inner end of the shrunken sleeve.
  - D. Slide the second sleeve over the splice and overlap the first sleeve by 2". Shrink the second sleeve down.
  - E. The cold shrink sleeve will not shrink completely down on the #2 cable. Seal the end of the sleeve with three layers of plastic tape from 1 inch on the sleeve to 1 inch on the cable jacket.

**CONSTRUCTION NOTE(s):**

1. When splicing a non-jacketed cable to a long length of jacketed cable, seal up the jacketed side per DCS **59 40 90 14**.
2. To splice a three phase cable, three Dist. Standards **41 34 40 02** will need to be called out.

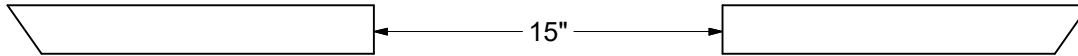
41 34 40 01	Single Phase Installation
41 34 40 02	Three Phase Installation

	ITEM	STK / DCS #	DESCRIPTION	41 34 40 **	01	02
@	A	17 55 854	Splice, Straight, #2 to 4/0 AL, 15 kV		1	1
	B	17 64 250	Connector - Shear Bolt		2	1
	C	17 55 443	Sleeve, Cold Shrinkable		1	1
	D	25 53 055	Tape - Plastic (RL)		1	1
		415	Op Code Splice 4/0 AL or CU Str. 15 kV		1	1

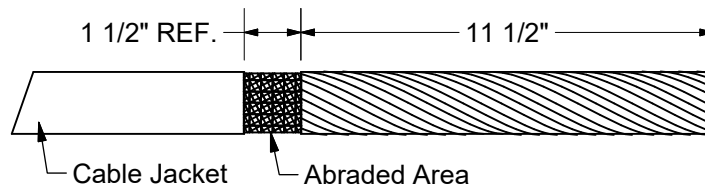
REV	DATE	ENG	DESCRIPTION
1	01/01/23	EB	New Standard

**INSTRUCTIONS - CONCENTRIC NEUTRAL WIRES OR FLAT STRAP SHIELDED CABLES:**

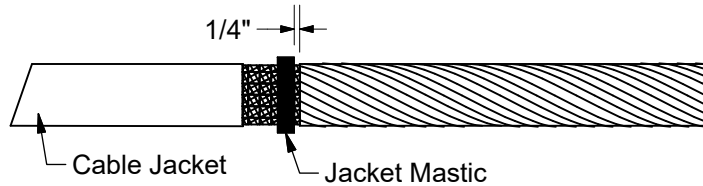
1. Positioning the cables:
  - A. Straighten and train the cable ends.
  - B. Cut the cables with 15" between them to allow space for the bus.
  - C. Clean the cable jacket up to 36" from the end of the cable.



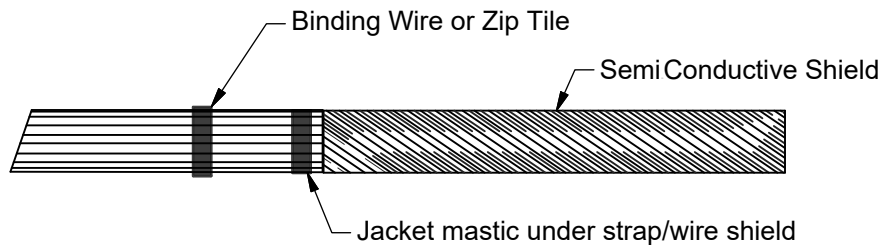
2. Exposing the Metallic Shield:
  - A. Remove the cable jacket 11-1/2" as shown below.
  - B. Abrade the area as shown.



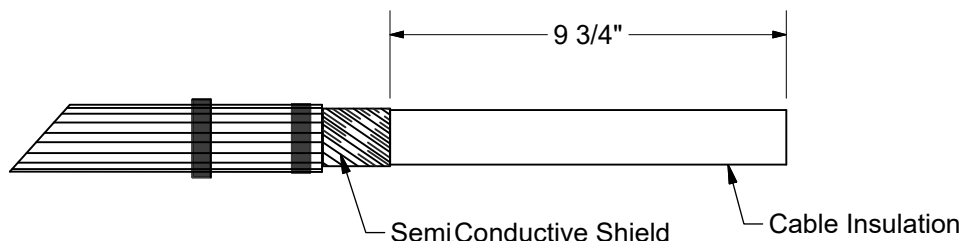
3. Apply the Jacket Mastic:
  - A. Apply one piece of jacket mastic at the position shown below by stretching and wrapping with light tension fully around the outer jacket.



4. Exposing the Cable Semi-Conductive Shield:
  - A. Fold back the wire / flat strap shields and press firmly into the jacket mastic.
  - B. Secure the wires / flat straps 3" back from the jacket mastic with a binding wire or zip tie as shown below.



5. Remove the semi-conductive shield 9-3/4" as shown below. Do not nick or cut the cable insulation.

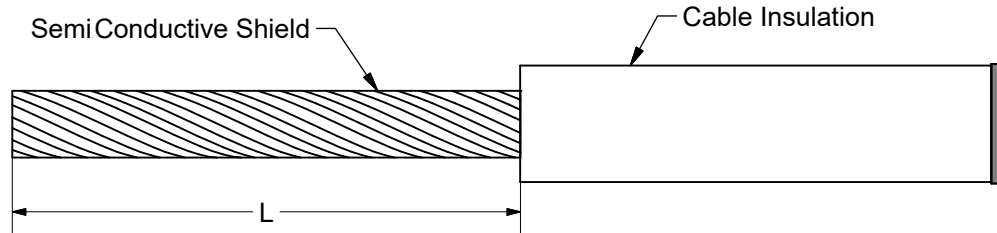




6. Remove the cable insulation for the length (L) in inches per each dis-con kit as shown below:

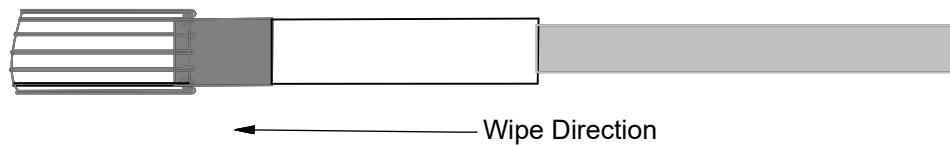
Kit Stock #	Length (L)
17 05 522	2"
17 05 525	2-3/4"
17 05 523	2-3/4"
17 05 524	3-3/8" *

\*Use as (L) for 1000 kcmil Cable



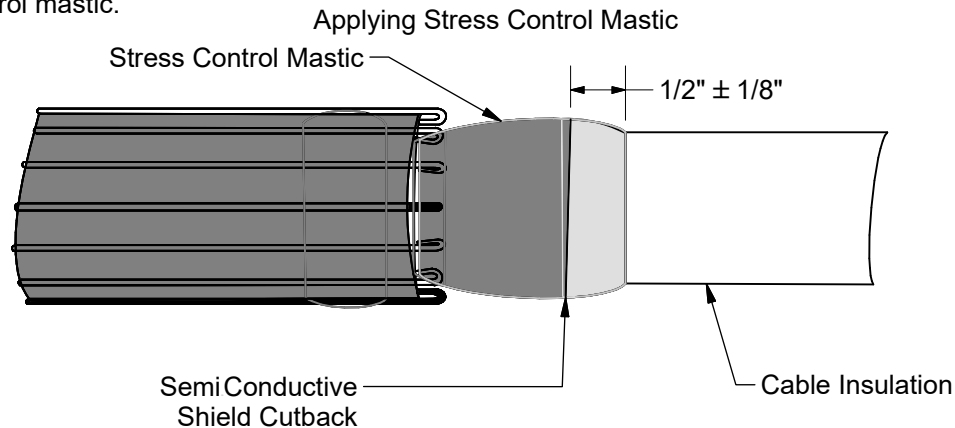
7. Repeat Steps 1 to 6 for the other cable(s).

8. Clean the insulation with the cleaning wipes by wiping from the lug to the shielding.



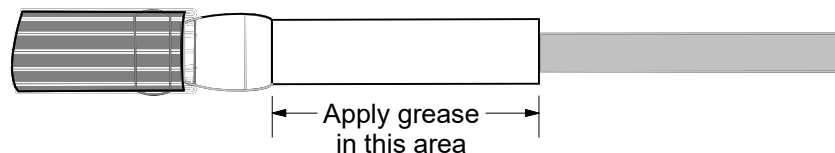
9. Applying the Stress Control Mastic.

A. Apply the stress control mastic centered over edge of semi-con shield cut back and overlapping the cable insulation by 1/2" as shown below. Apply the mastic with light tension so that it slightly stretches and completely wraps the cable. If installing 15kV #2 cable, use the smaller piece of stress control mastic.



10. Applying Grease

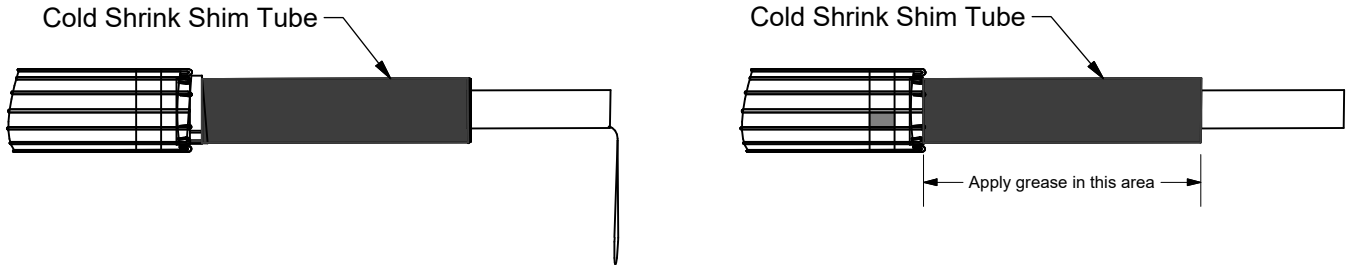
A. Apply grease over the cable insulation as shown below. Use only the grease supplied in the kit. Avoid applying any grease on the stress control mastic; this may prevent adhesion to the sealing mastic in Step 19.



11. Installing the Shim Tube:

For Stock #17 05 522 (15kV #2 AWG DIS-CON KIT) ONLY.

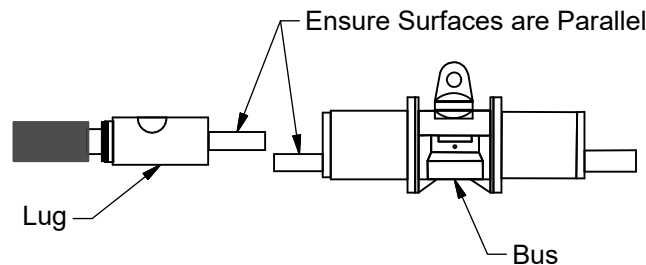
- Align the cold shrink shim tube over the cable end so that the tube will land over the applied stress control mastic, butted up to the concentric wire / flat strap fold back.
- Unwind the spiral holdout to shrink the sleeve in place.
- Once deployed, insulation may extend slightly past end of shim tube.
- Clean shim tube surface. Apply grease over shim tube.



12. Installing the Lug:

- Clean the conductor. For aluminum conductor, wire brush and immediately insert the lug onto the conductor. Slide the lug until the conductor is fully seated within the lug barrel.
- Rotate the lug so that the spade is parallel to the contact face of the bus as shown.
- Snug all of the bolts starting with the bolt closest to the cable insulation and moving towards the lug pad.
- Shear off all of the bolts in the same order.
- See the table below for the correct Allen Hex socket for each lug and dis-con kit.

Cable	Table 1 - Dis-Con Kit Socket Selection		
	Lug	Dis-Con Kit	Allen Hex Socket
1/0-500	17 55 843	17 05 523 & 17 05 525	86 44 455 (6mm)
#2	17 55 842	17 05 522	86 44 454 (5mm)
750 kcmil	17 55 844	17 05 524	85 35 776 (8mm)
1000 kcmil	17 55 846	-	85 35 776 (8mm)



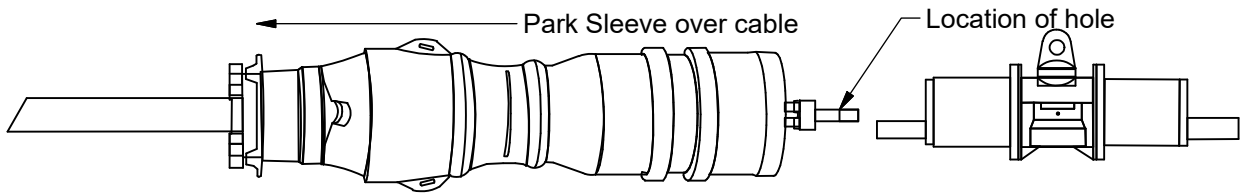
13. Checking the Lug:

- Confirm that the distance after installing the lug does not exceed the 7-1/8" dimension shown below.



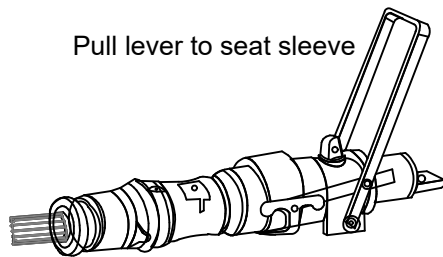
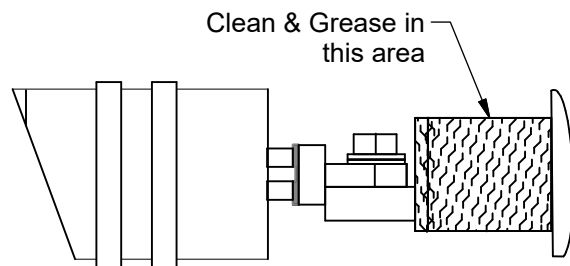
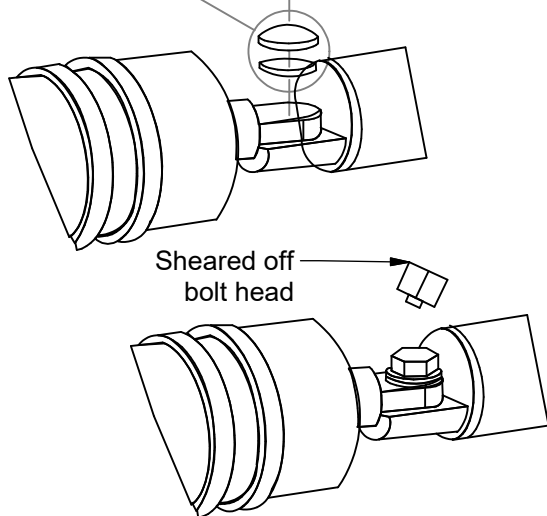
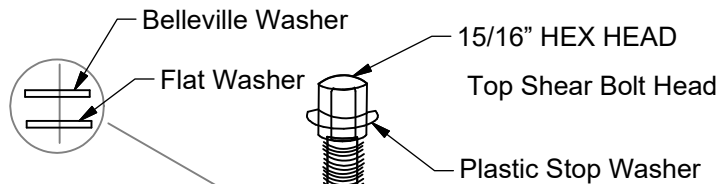
14. Parking the Sleeve:

- A. Slide the sleeve body over the cable so that the hole in the lug is visible as shown below.



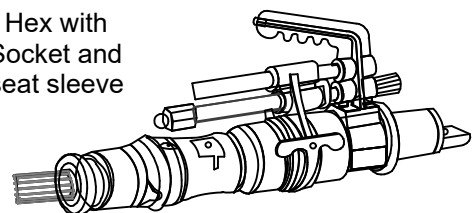
15. Installing the Sleeve:

- A. Position the Belleville washer and the flat washer as shown.  
 B. Insert the bolt through the lug and hand tighten the bolt to ensure that all of the cables fit on the bus.  
 C. Tighten the top 15/16" shear bolt head until it shears off.  
 D. Clean the splice interface as shown.  
 E. Apply grease over the bus interface as shown. Use only the grease supplied in the kit.  
 F. Slide the sleeve body over the lug and push it onto the bus. This can be accomplished by hand or by use of an installation tool as shown below.



Installation/Removal tool (optional)

Engage Hex with 15/16" Socket and turn to seat sleeve



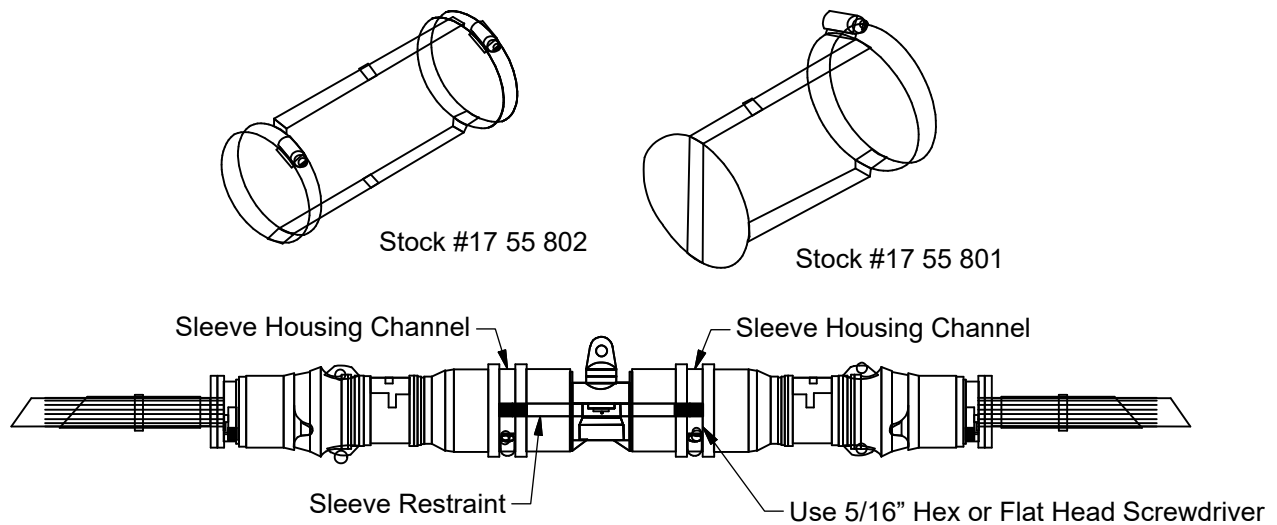
Installation/Removal tool (optional)

16. Repeat Steps 1 to 15 for the other cables.

REV	DATE	ENG	DESCRIPTION
16	01/01/23	EJB	Converted to new format
15	07/01/19	EJB	

17. Sleeve Restraints:

- A. Apply sleeve restraints in the sleeve housing channels.
- B. The hose clamp can be tightened with a 15/16" hex or flat headed screwdriver. Fully tighten the hose clamp on the sleeve restraint until the screw "clicks". It is designed to click when fully tightened and cannot be over-tightened.
- C. Apply the sleeve restraints as follows:
  - a. I Splice: one Stock #17 55 802 double end.
  - b. Y Splice: one Stock #17 55 802 double end and one Stock #17 55 801 single end.
  - c. H Splice: two Stock #17 55 802 double ends.
  - d. U Splice: two Stock #17 55 801 single ends.
  - e. E Splice: three Stock #17 55 802 double ends
- D. If sleeves are not fully seated onto splice, the sleeve restraints cannot be installed.



18. Removing the Core From the Sleeve:

- A. Grasp the removal ring. Push the ring against the core flange and twist so that the cutting teeth break the tape on both sides. Check that the tape is broken.
- B. Completely remove the core from the rubber housing by hand. DO NOT twist the core while removing it.



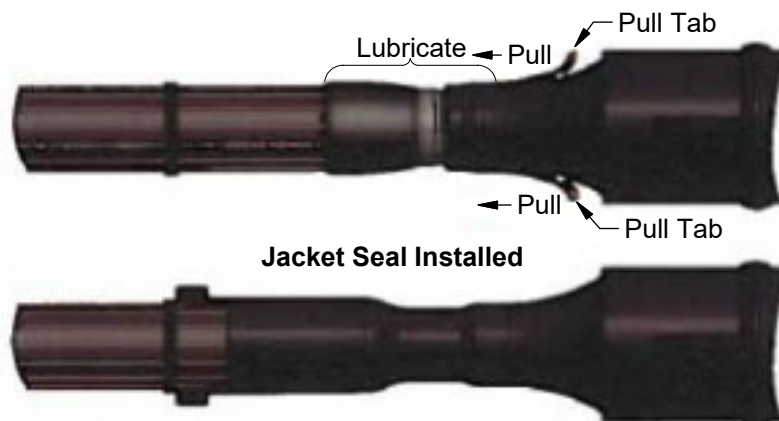
19. Applying the Sealing Mastic:

- A. Apply sealing mastic to overlap the stress control mastic and completely overlap the jacket mastic as shown below.
- B. Compress the sealing mastic to create a smooth transition to the stress control mastic. This will assist during jacket seal application.



20. Applying the Jacket Seal:

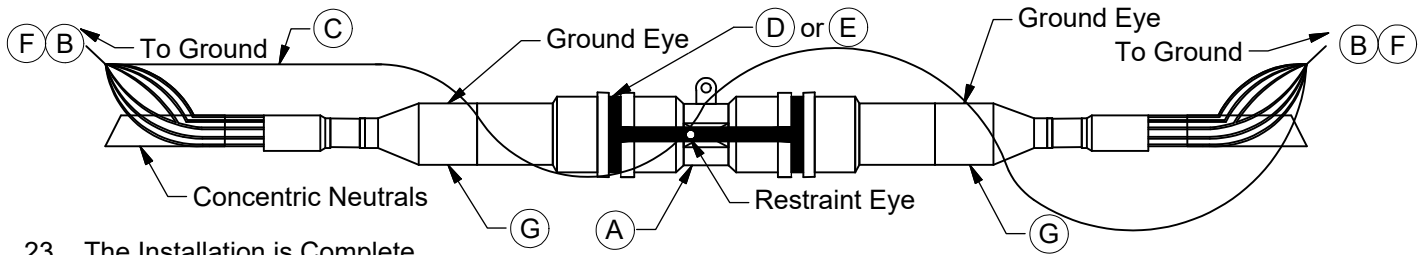
- A. Apply grease over the area as shown. Only use the silicone grease supplied with the kit.
- B. Hold onto both of the tabs and pull out to completely cover the sealing mastic as shown below.
- C. Ensure that the sealing mastic is not dislodged when unfolding the seal.



21. Repeat Steps 17 to 20 for other cable(s).

22. Connecting the Splice to Ground:

- A. For each cable, insert one end of a #14 wire through the restraint eyelet and twist to make a small loop.
- B. Wrap the other end through the sleeve eyelet and connect to the shield wires with two bolt clamps.
- C. Connect the neutral wires to ground wiring 600V #2 AWG copper covered wire.

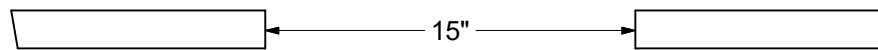


23. The Installation is Complete.

INSTRUCTIONS - LC SHIELDED CABLES:

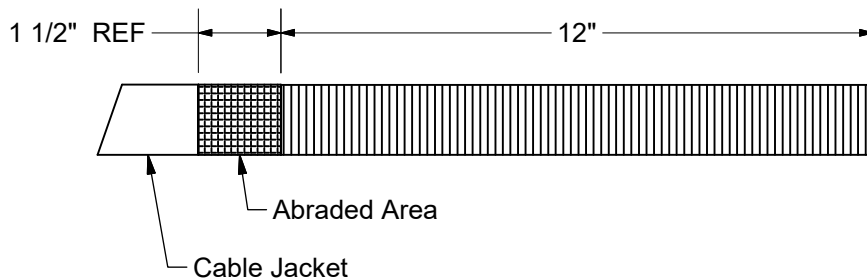
1. Positioning the Cables:

- A. Straighten and train the cable ends.
- B. Cut the cables with 15" between them to allow space for the bus.
- C. Clean the cable jacket up to 36" from the end of the cable.



2. Exposing the Metallic Sheath:

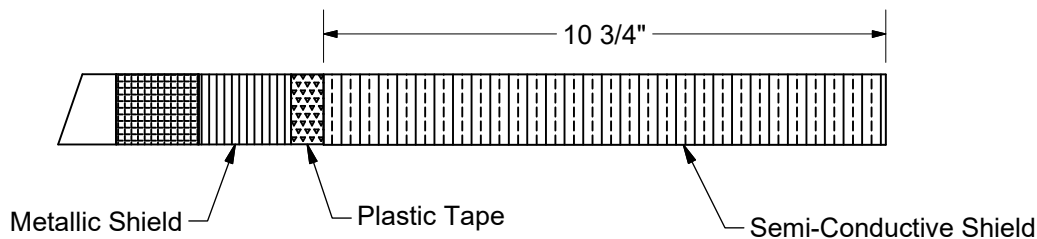
- A. Remove the cable jacket to the dimensions shown below.
- B. Abrade the area as shown.



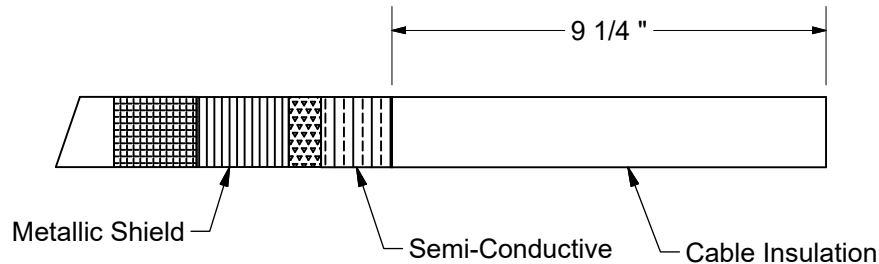
3. The jacket mastic will be applied in Step 13.

4. Exposing the Semi-Conductive Shield:

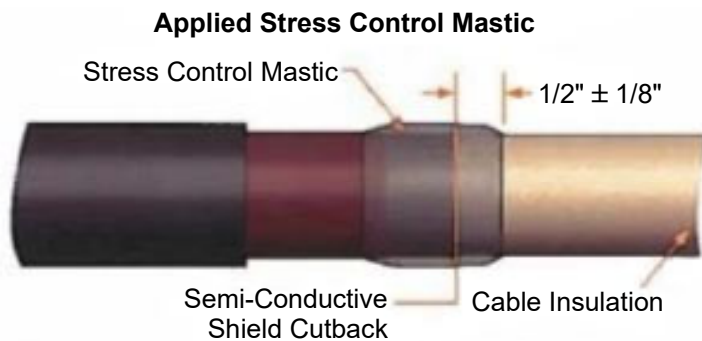
- A. Wrap two layers of plastic tape at the dimension shown below to secure the metallic shield.
- B. Remove the metallic shield up to the plastic tape as shown below.



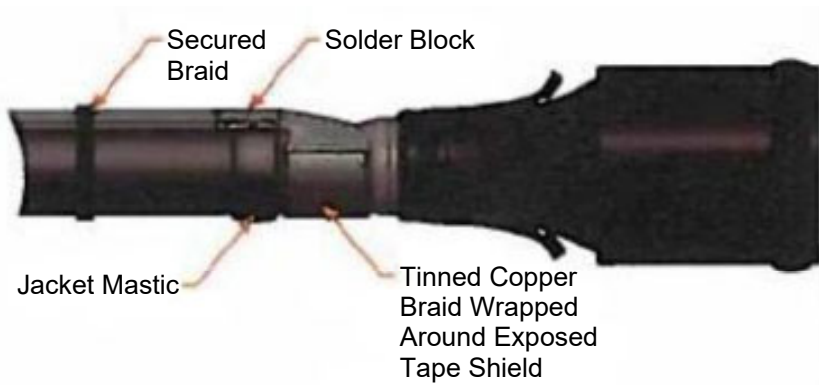
5. Exposing the Cable Insulation
  - A. Remove the semi-conductive shield to the dimension shown below. Do not nick or cut the cable insulation.



6. Exposing the Conductor
  - A. Remove the cable insulation based on the cable kit stock number shown in Step 6 for the wire shielded cable.
  - B. Do not cut or nick the cable strands.
7. Repeat Steps 1 through 6 for the other cable(s).
8. Applying the Stress Control Mastic:
  - A. Remove the plastic tape from Step 4.
  - B. Apply the stress control mastic on tip of the exposed semi-con shield cutback and overlapping the cable insulation by 1/2" as shown below. Allow the mastic with light tension so that it slightly stretches and completely wraps the cable.



9. Applying Grease:
  - A. Apply grease over the exposed cable insulation as shown. Use only the grease supplied in the kit. Avoid applying any grease on the stress control mastic as it may prevent adhesion to the sealing mastic applied later on.
10. Install and check the Lug Dimension and Park and Install the Sleeves in the Same Manner as the Wire Shielded Cable. Repeat Steps 8 through 10 for the Other Cable(s).
11. Add Sleeve Restraints to all Cables. See instructions for Wire Shielded Cables.
12. Remove the Core on Each Cable. See the Instructions for Wire Shielded Cables.
13. Preparing the Metallic Shield:
  - A. Install the jacket seal mastic on the cable jacket aligned with the jacket cutback.
  - B. Wrap tinned copper braid around the exposed LC shield.
  - C. Align the edge of the solder block with the jacket cutback.
  - D. Secure the copper braid 3" back from the end of the jacket mastic with zip tie or binding wire.



- E. Install the constant force spring over the wrapped copper braid.
- F. Wrap two layers of plastic tape over the constant force spring.
- G. Press the solder block into the jacket mastic.



14. Applying the Sealing Mastic:

- A. Align the sealing mastic to completely overlap the jacket mastic as shown below.
- B. Compress the sealing mastic to create a smooth transition to the stress control mastic; this will assist during the jacket application.



**Sealing Mastic Installed**

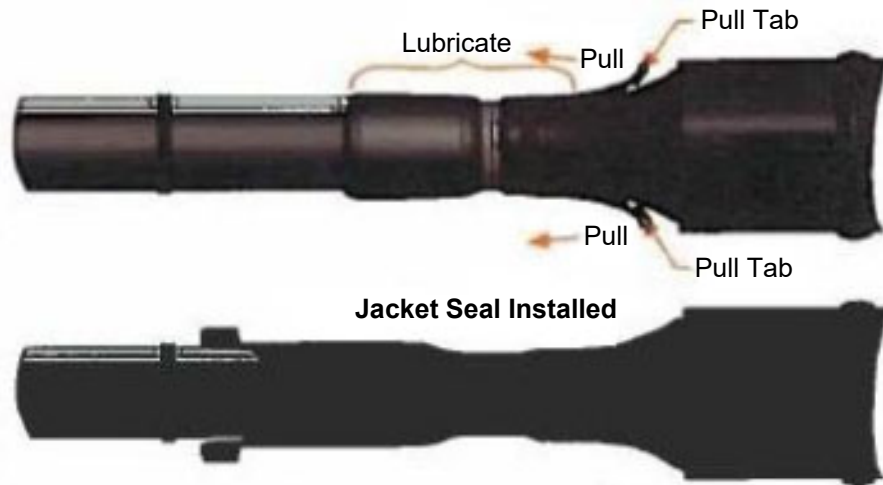


REV	DATE	ENG	DESCRIPTION
16	01/01/23	EJB	Converted to new format
15	07/01/19	EJB	



15. Applying the Jacket Seal:

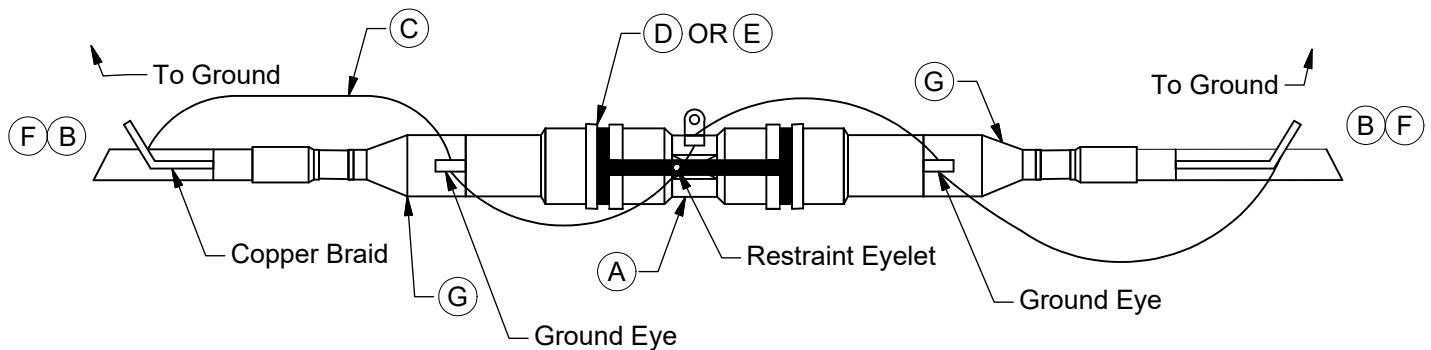
- Apply grease over the area shown below. Only use grease supplied with the kit.
- Hold onto both tabs and pull out to completely cover the sealing mastics as shown below.
- Ensure that the sealing mastic is not dislodged when unfolding the seal.



16. Repeat Steps 13 to 15 for the other cables.

17. Connecting the Splice to Ground:

- For each cable insert one end of a #14 wire through the restraint eyelet and twist to make a small loop.
- Wrap the other end through the sleeve eyelet and connect to the copper braids with two bolt clamps.
- Connect the copper braids to ground using 600V #2 copper covered wire.



18. The Installation is Complete.



# UNDERGROUND CABLE SPLICE

Premolded Separable  
#2 Through 1000 kcmil Cu or Al

<b>41 35 31 **</b>
<b>15-35kV</b>
<b>11 of 12</b>

**Table 2 - Dis-Con Kit Selection**

<b>Cable Size</b>	<b>Dis-con Kit Stock #</b>
750 NSR, 5kV	17 05 524
#2 AL, CNR, P, 15 kV	17 05 522
4/0 AL, CNR, P, 15 kV	17 05 525
350 FSR, P, RW, 15 kV	17 05 525
350 CNR, P, 15 kV	17 05 523
500 AL, CNR, P, 15 kV	17 05 523
750 FSR, P, RW, 15 kV	17 05 524
750 AL, CNR, P, 15 kV	17 05 524
750 CNR, P, 15 kV	17 05 524
1000 TSR, P, 15 Kv	17 05 528 (Sleeve) & 17 55 846 (Lug) & 21 53 112 (Barrier Bolt)
1/0 AL, CNR, P, 35 kV	17 05 523
350 CNR, P, 35 kV	17 05 523
750 FSR, P, 35 kV	17 05 524

<b>DCS#</b>	<b>Description</b>
41 35 31 01	I Splice (2-way)
42 35 31 02	Y Splice (3-way)
43 35 31 03	H Splice (4-way)
44 35 31 04	U Splice (2-way)
45 35 31 05	E Splice (6-way)
46 35 31 06	L Splice (2-way)

REV	DATE	ENG	DESCRIPTION
16	01/01/23	EJB	Converted to new format
15	07/01/19	EJB	



# UNDERGROUND CABLE SPLICE

Premolded Separable  
#2 Through 1000 kcmil Cu or Al

<b>41 35 31 **</b>
<b>15-35kV</b>
<b>12 of 12</b>

-	ITEM	STK / DCS #	DESCRIPTION	41 35 31 **	01	02	03	04	05	06
	A	17 05 530	Bus Bar, I Splice, 15/35 kV (2-way)		1	-	-	-	-	-
		17 05 372	Bus Bar, Y Splice, 15/35 kV (3-way)		-	1	-	-	-	-
		17 05 529	Bus Bar, H Splice, 15/35 kV (4-way)		-	-	1	-	-	-
		17 05 541	Bus Bar, U Splice, 15/35 kV (2-way)		-	-	-	1	-	-
		17 55 851	Bus Bar, E, Splice, 15/35 kV (6-way)		-	-	-	-	1	-
		17 55 852	Bus Bar, L, Splice, 15/35 kV (2-way)		-	-	-	-	-	1
	B	18 54 027	Wire - #2 Copper, 600 V Cov.		12	12	20	12	25	12
	C	18 52 018	Wire - #14 Copper, Binding, Bare		5	8	10	5	12	5
	D	17 55 801	Restraint - Splice, Single Housing End		-	1	-	2	-	-
	E	17 55 802	Restraint - Splice, Double Housing End		1	1	2	-	-	-
	F	17 54 140	Connector - Wire, #8 - 4/0 CU, 2 Bolt		2	2	2	2	2	2
	@ G	17 05 522	Dis-con Kit, #2 AWG 15 kV Only		#	#	#	#	#	#
		17 05 525	Dis-con Kit, 1/0 - 350 kcmil RW 15 kV		#	#	#	#	#	#
		17 05 523	Dis-con Kit, 350 - 500 kcmil 15 kV & 1/0 - 350 kcmil 35 kV		#	#	#	#	#	#
		17 05 524	Dis-con Kit, 750 kcmil 5/ 15/ 35 kV		#	#	#	#	#	#
	@ H	17 54 306	Connector Cable Grounding, 15-35 kV		#	#	#	#	#	#
	@ I	17 05 315	Cap - Insulating End		#	#	#	#	#	#
6@	J	17 05 526	Sleeve Only, #2 - 350 kcmil RW 15 kV, with Shim Tube		#	#	#	#	#	#
6@	K	17 05 527	Sleeve Only, 350 kcmil RW 15 kV and 1/0 - 350 kcmil 35 kV		#	#	#	#	#	#
6@	L	17 05 528	Sleeve Only, 750 kcmil 5 / 15 / 35 kV, 1000 kcmil 15 kV		#	#	#	#	#	#
7@	M	17 55 842	Lug Only, #2 AWG 15 kV, AL / CU		#	#	#	#	#	#
7@	N	17 55 843	Lug Only, 1/0 - 500 kcmil, AL / CU		#	#	#	#	#	#
7@	O	17 55 844	Lug Only, 350 - 750 kcmil, AL / CU		#	#	#	#	#	#
7@	P	17 55 846	Lug Only, 1000 kcmil, AL / CU		#	#	#	#	#	#
@	Q	21 53 112	Bolt - Barrier, Shear, with Washer and Belleville Washer		#	#	#	#	#	#

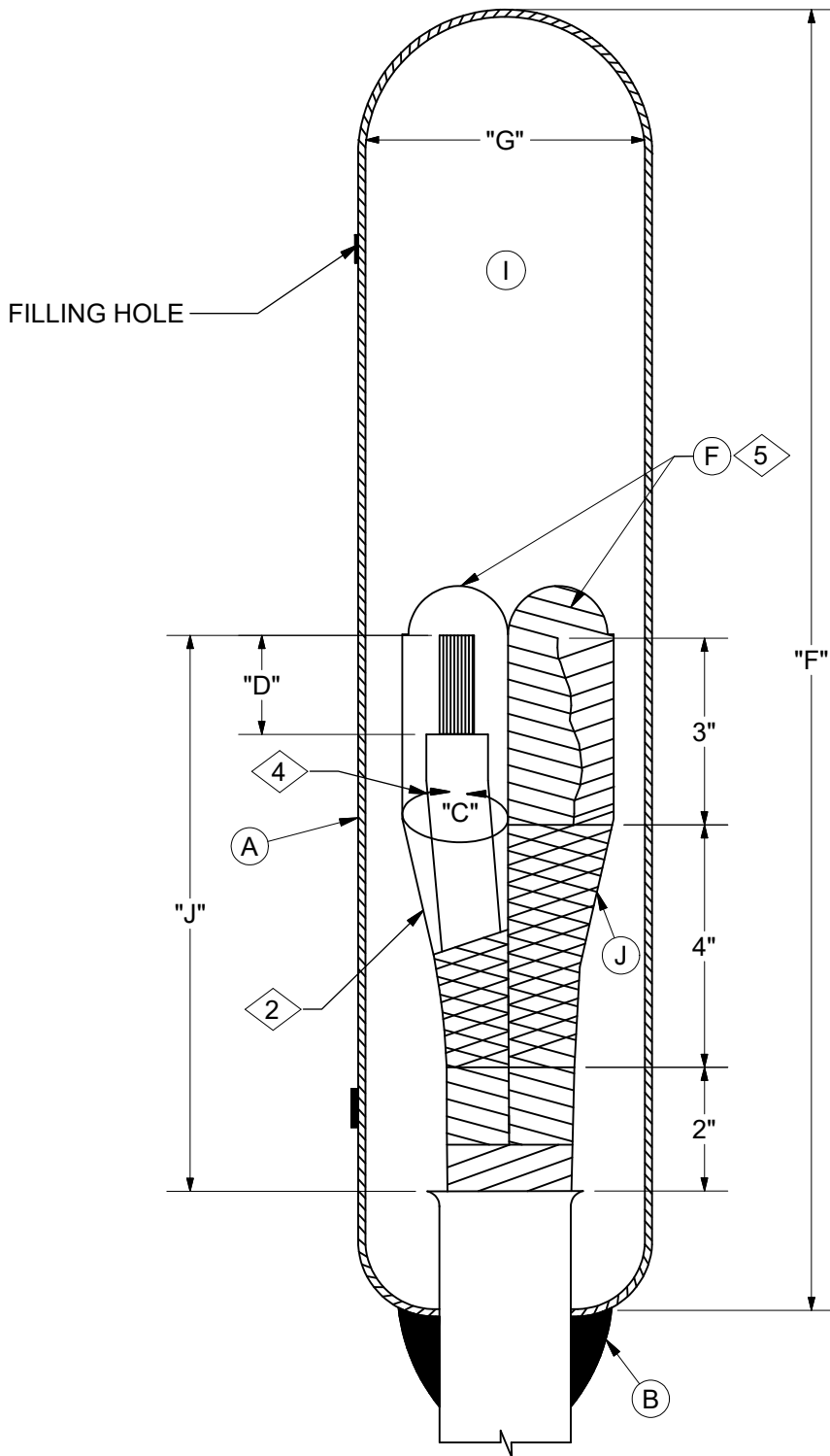
**DESIGN NOTE(s):**

1. For each "I" or "U" or "L" Splice (Item A) choose a combination of two Dis-con kits (Item G) or a Dis-con kit and an End Cap (Item I). Restraints are included with the "L" bus.
2. For Each "Y" Splice (Item A) choose a combination of three Dis-con kits (Item G) or Dis-con kit(s) and End Cap(s) (Item I).
3. For Each "H" Splice (Item A) choose a combination of four Dis-con kits (Item G) or Dis-con kit(s) and End Cap(s) (Item I).
4. For Each "E" Splice (Item A) choose a combination of six Dis-con kits (Item G) or Dis-con kit(s) and End Cap(s) (Item I). Restraints are included with the "E" bus.
5. For a three-phase cable splice installation the selected bus, Dis-con kits, and grounding materials should be multiplied by three.
6. When reconnecting cables to the splices, use the Sleeve Only Items (J, K, and L).
7. When replacing a shear bolt lug, use the Lug Only Items (M, N, O, and P).

**OPERATIONS NOTE(s):**

8. A Test Point Indicator (Stock #17 05 483) may be applied to the bus to show that the splice is energized. However, a non-indication of the Test Point Indicator should not be used to prove that the splice is de-energized.

REV	DATE	ENG	DESCRIPTION
16	01/01/23	EJB	Converted to new format
15	07/01/19	EJB	



REV	DATE	ENG	DESCRIPTION
2	01/01/23	EJB	Converted to new format
1	10/07/10	EJB	



# UNDERGROUND CABLE SPLICE

Test Cap

1/0 Thru 800 kcmil 3 Cond. Lead Cable (Belted or Shielded)

41 36 11 \*\*

5kV - 15kV

2 of 2

CONSTRUCTION NOTE(s):

1. Shielded joint shown. For belted joint, omit shielding braid.
2. Shielding braid to be butt wrapped and soldered in a line along top and to cable shielding avoid openings between wrapping.
3. Unless otherwise noted, Petrolatum is referred to as "Compound", "Oil Insoluble Compound", or "Insulating Compound" in the standard drawings.
4. Terminate shielding braid at this point.
5. Apply 3 layers of 1/2 Lapped VP tape.

Dimensions Table								
DCS#	SIZE OF CABLE	CIRCUMFERENCE OVER INSULATION "C"		LENGTH OF BARE COPPER "D" (IN)	LEAD SLEEVE		LENGTH LEAD REMOVED "J"	
		5000V (IN)	15000V (IN)		LENGTH "F" (IN)	I.D. "G" (IN)	5kV (IN)	15 kV (IN)
41 36 11 01	1/0	3	3-7/8	1-3/8	20	3-1/2	9	11
42 36 11 02	4/0	3-5/8	4-5/8	1-5/8	21	4	9	11
43 36 11 03	300 kcmil	4-1/4	5	1-5/8	22	4-1/2	9	11
44 36 11 04	350 kcmil	4-3/8	5-1/4	1-5/8	22	4-1/2	9	11
45 36 11 05	500 kcmil	5-1/4	-	2	22	4-1/2	9	-
46 36 11 06	800 kcmil	5-7/8	-	2-5/8	24	5	10	-
47 36 11 07	800 kcmil	-	6-7/8	2-5/8	24	5-1/2	-	13

ITEM	STK / DCS #	DESCRIPTION	41 36 11 **	01	02	03	04	05	06	07
A	12 53 062	Sleeve – Lead, 3 1/2" x 20"		1	-	-	-	-	-	-
	12 53 063	Sleeve – Lead, 4" x 21"		-	1	-	-	-	-	-
	12 53 064	Sleeve – Lead, 4 1/2" x 22"		-	-	1	1	1	-	-
	12 53 065	Sleeve – Lead, 5" x 24"		-	-	-	-	-	1	-
	12 53 052	Sleeve – Lead, 5 1/2" x 28"		-	-	-	-	-	-	1
B	22 02 282	Solder – Wiping (Lb.)		12	12	12	12	12	12	12
C	22 02 273	Solder – 50 – 50 (Lb.)		2	2	2	2	2	2	2
D	22 02 276	Solder – String, 1/4" (Lb.)		1	1	1	1	1	1	1
E	22 02 255	Solder – Paste (Cn.)		1	1	1	1	1	1	1
F	25 53 022	Tape – V.P., 1" x 8 Yd. (Rl.)		1	1	1	1	1	1	1
G	31 53 007	Stearine (Ea.)		1	1	1	1	1	1	1
H	22 05 213	Cloth – Sanding, 1 1/2" W (Ft.)		2	2	2	2	2	2	2
I	31 51 062	Petrolatum – 3 Lb. Pkg. (Pk.)		1	1	1	1	1	1	1
J	18 66 101	Braid – Copper Mesh, 1" x 15' (Rl.)		3	3	3	3	3	3	3
	435	Op Code Test Cap 15 kV		1	1	1	1	1	1	1

**DISTRIBUTION  
CONSTRUCTION STANDARDS**

REV	DATE	ENG	DESCRIPTION
2	01/01/23	EJB	Converted to new format
1	10/07/10	EJB	

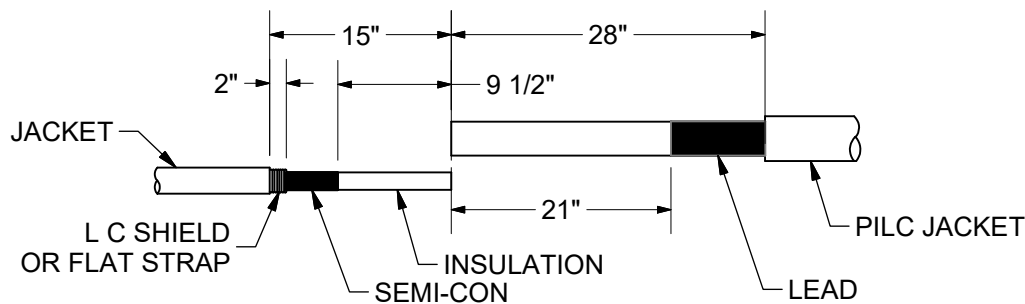
## INSTRUCTIONS:

### 1. Heat Shrink Basics

- Adjust the flame so that it is an overall 12" bushy flame.
- Apply outer 3" to 4" tip of the flame to heat shrinkable material with a rapid brushing motion.
- Unless otherwise instructed start shrinking tubes at center working the flame around all sides of the tubes to apply uniform heat.
- Concentrate on heating the back of the tubes as well as the front of the tubes.
- If it is necessary to interrupt the shrinking process and the tubes cool, you must reheat prior to shrinking the next tube.
- Inspect all installed tubes. Reheat any flat spots or wrinkles, paying particular attention to the back of the splice.

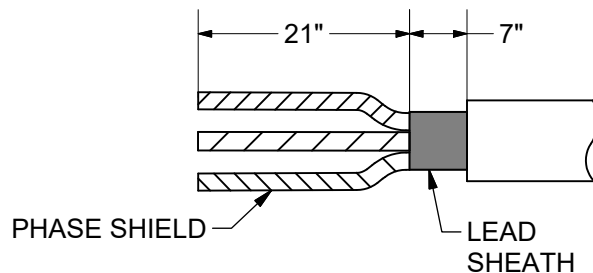
### 2. Prepare Cables

- Secure the end of the strap or LC Shield with a length of copper foil tape or a minimal width of plastic tape.



### 3. Prepare and Remove Lead Sheath

- Remove lead oxide from the lead sheath and clean with an approved solvent. Remove the lead sheath as shown.



### B. For Phase Holding

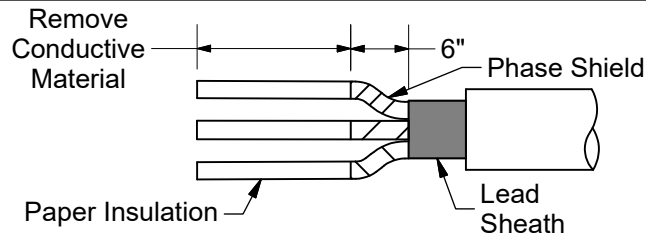
If an existing 3/C PILC cable is being cut and spliced to three new single conductor cables, "Phase Holding" may be required. After opening the lead sheath to expose the shielded phase conductors, place several wraps of colored tape around each phase before cutting the conductors. Use "white" to signify the "Held Phase A", blue to signify the "Held Phase B", and "red" to signify the "Held Phase C". The phase colors do not identify the actual phases but they represent the "Held Phase" of the system.

Due to the covering of the phases during the preparation of the splice, it will be necessary to move the markers several times throughout the splicing process. Each time the "Phase Holding" tape is to be moved to a new location, "Phase Holding" will be noted in the installation instructions.

If "Phase Holding" is not a requirement for this splice, then the "Phase Holding" comments should be ignored.

### 4. Remove Shield

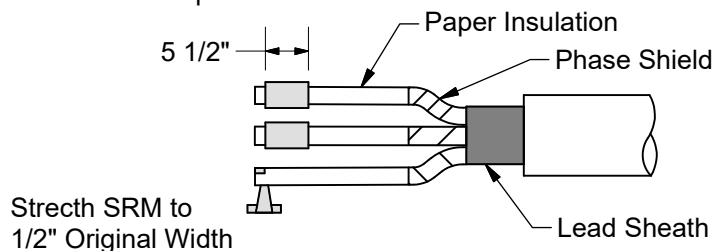
- Cut back and bedding and/or shield tapes over all three phases to the lead sheath cutback.
- Cut back phase shields and remove any conductive material from paper insulation as shown.



C. Tape phase shields at edge to prevent unwrapping. DO NOT use string. use one wrap of colored "Phase Holding" tape or plastic tape.

5. Apply Stress Relief Material (SRM)

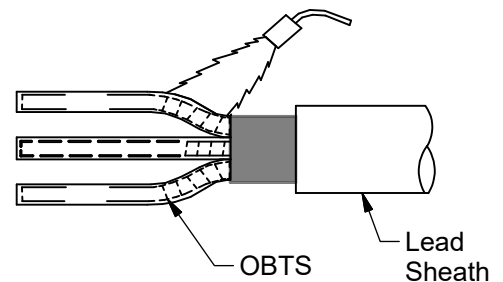
- A. Mark the insulation 5-1/2" from the end of the PILC cable.
- B. Remove the backing strip from one side of a long strip of SRM.
- C. Roll up the SRM and remaining backing strip into a convenient size.
- D. Removing the remaining backing strip, tightly wrap one half lapped layer of SRM around each phase from the cable end to the mark. Wrap the SRM in the same direction as the insulating papers on the cable.



6. Position and Shrink Oil Barrier Tubes (OBT)

- A. Place an oil barrier tube over each phase, butted to the lead sheath cutback.
- B. Shrink the OBT's in the crotch area first. After the crotch is done, shrink one tube at a time.
- C. Inspect the installed OBT's. The OBT's should have a smooth, wrinkle free surface after shrinking. Reheat to smooth any wrinkled areas.

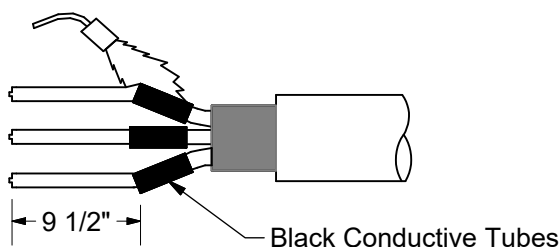
- 1. OBT may shrink 1/4" - 1/2" away from lead sheath cutback. This is okay.
- 2. To achieve a smooth wrinkle free installation, use a reduced flame to install the thin walled OBT's.



D. Phase Holding: Wrap a layer of "Phase Holding" tape to the connection end of the OBT before positioning and shrinking the black conductive tubes.

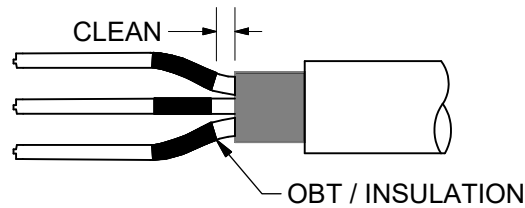
7. Position and Shrink Black Conductive Tubes

- A. Place a black conductive tube over each phase and position as shown.
- B. Shrink the tubes in place starting at the end nearest to the center of the splice.

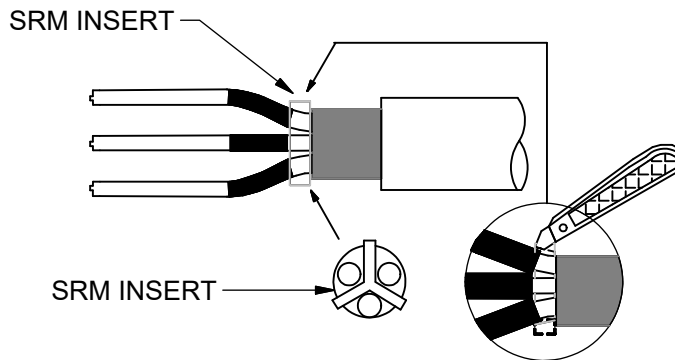


REV	DATE	ENG	DESCRIPTION
2	01/01/23	EJB	Converted to new format
1	05/25/07	EJB	

8. Clean OBT's and Install SRM Insert
- A. Using an approved solvent, clean the OBT/insulation, as shown.

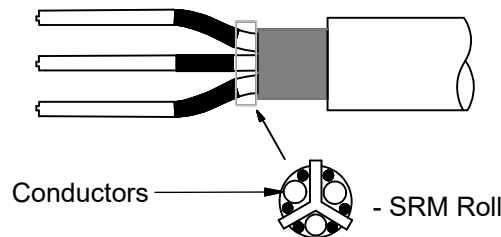


- B. Assemble SRM insert per box instructions.  
 C. Spread the phases and position the SRM insert as shown.  
 D. Trim the SRM insert to extend 1/8" beyond each phase.  
 E. Reclean the lead sheath using an approved solvent.



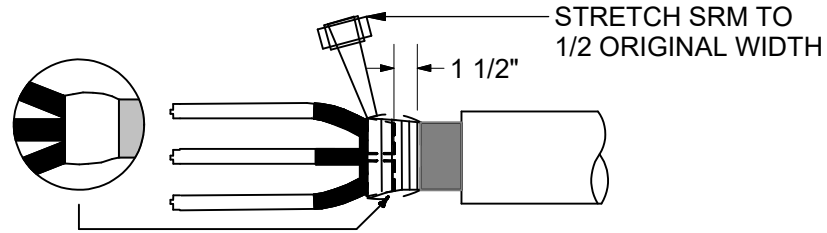
- F. The SRM insert is packaged inside the conductive breakout.

9. Fill Gaps Between SRM Insert and Conductors
- A. Cut a 6" piece of SRM into six 1" strips.  
 B. Remove the backings and roll up each 1" piece.  
 C. Place two of the SRM rolls on each side of the SRM insert to fill the gaps between the insert and the conductors as shown.



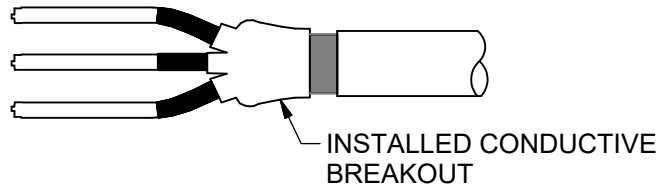
10. Install Oil Seal
- A. Mark the lead sheath 1-1/2" from the end.  
 B. Remove the backing from one side of a long strip of SRM. Roll the SRM and remaining backing strip into a convenient size.  
 C. While removing the remaining backing strip, tightly wrap the SRM from the mark on the lead sheath to the outer edge of the SRM insert.  
 D. Four to six strips of SRM should be used to build the SRM to the shape shown.
- a. The SRM will stick better if the lead sheath is preheated.  
 b. DO NOT over apply SRM, the finished diameter must not exceed that of the breakout boot.





11. Position and Shrink Conductive Breakout

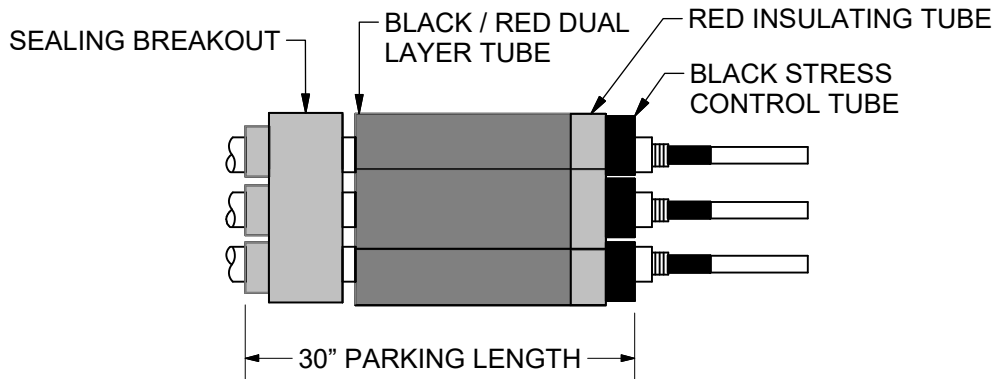
- Position the conductive breakout over the SRM so that the inside butts up hard against the SRM.
- Shrink the conductive breakout in place starting at the fingers and working toward the other end.
- After the breakout has shrunk continue to apply heat until the breakout has a smooth, uniform surface.



- "Phase Holding": After breakout is cool, apply "Phase Holding" tape to the fingers of the cable breakout (last and final location for "Phase Holding" tape).

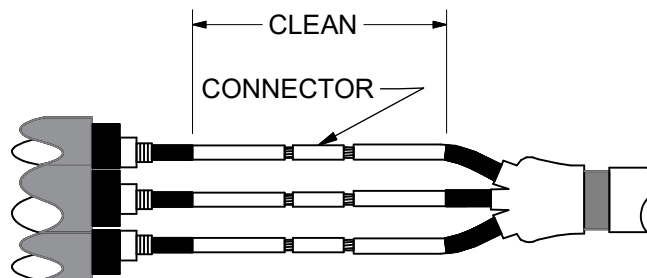
12. Position Splice Components on Solid Dielectric Cables

- Clean 30" of cable jacket.
- Place sealing breakout over the cables with the fingers pointing away from the splice center.
- Place one set of nested tubes over each clean cable.

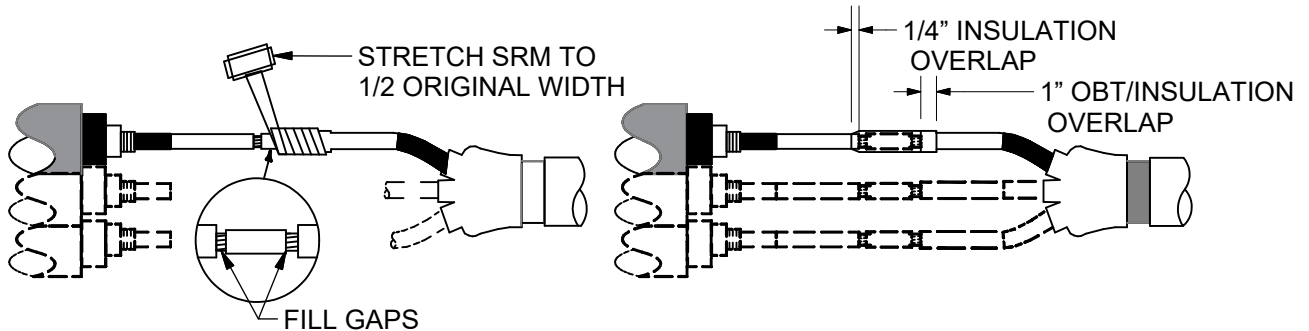


13. Remove Insulation and Install Connectors

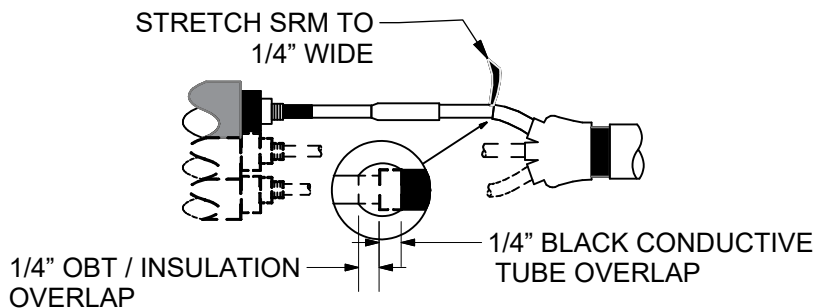
- Determine the insert depth of the connector.
- The insulation cutback should equal the connector insert depth plus 1/4".
- Chamfer or cut the sharp edge off of the EPR insulation for 1/4".
- Install the connectors. Protect the OBTs, if using soldered connector by wrapping them with cotton or glass fiber tape.
- Make sure connections are smooth.
- Using an approved solvent, clean the insulation as shown. Pay particular attention to the OBT/insulation surface.



14. Apply SRM Over Connector (Complete Steps 14 and 15 working on one phase at a time.)
- Remove backing from one side of a long strip of SRM, roll the SRM and remaining backing strip into a convenient size.
  - While removing the remaining backing strip, tightly wrap the SRM around the connector and exposed conductor. Be sure to fill the gaps and low spots around the connector.
  - Continue to wrap the SRM onto the insulation as shown.

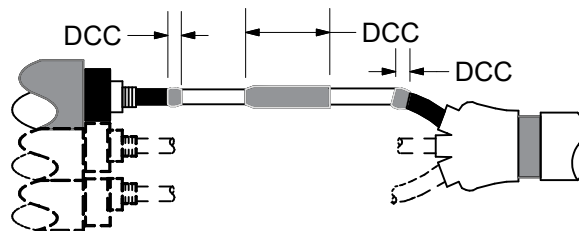


- If the connector diameter is larger than the insulation diameter, apply two half lapped layers of SRM over the entire connection.
15. Apply SRM at Black Conductive Tube and Semi-con Steps, Apply Discharge Control Compound, and Then Position Black Stress Control Tube
- Remove the backing from the short angle-cut piece of SRM. Place the tip of SRM at the black conductive tube step and tightly wrap to fill the step. Overlap black conductive tube and OBT/insulation and taper as shown.
  - Repeat the above procedure for the semi-con step.

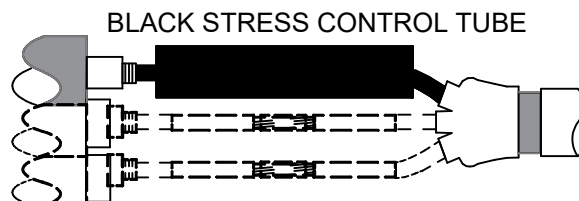


- Snip open the end of DCC tube and apply thin film of compound on the SRM over the connector and semi-con steps.

APPLY THIN FILM OF DCC OVER SURFACE OF INSTALLED SRM



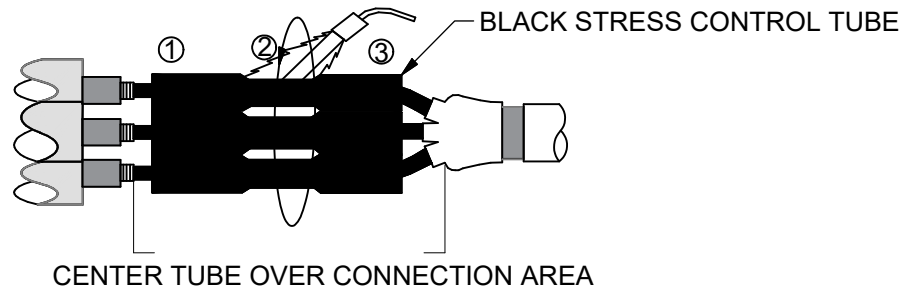
- Center the black stress control tube over the completed connector area. Be sure to equally overlap the semi-con and the black conductive tube.



COMPLETE STEPS 14 AND 15 FOR THE REMAINING TWO PHASES BEFORE PROCEEDING TO STEP 16.

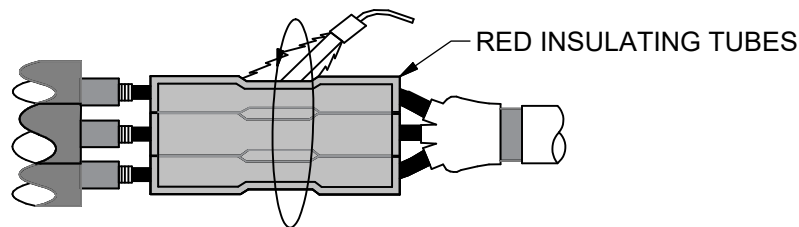
## 16. Shrink Black Stress Control Tubes

- Make sure that each tube is centered over the connection area, equally overlapping the semi-con and black conductive tube.
- Shrink all three tubes in place at the same time.
- Begin shrinking at center of tubes (1), working torch with a smooth brushing motion around the tubes.
- After center portions shrink, work torch toward one end (2), then to opposite end (3). Post heat all tubes.
- Apply sufficient heat to ensure softening of the SRM, indicated by a smooth surface profile.



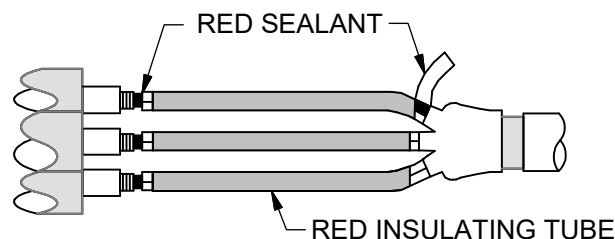
## 17. Position and Shrink Red Insulating Tubes

- Center red insulating tubes over the black stress control tubes.
- Shrink in place using the same method as Step 16.
- Do not allow the red insulating tubes to cool before applying red sealant and installing the black/red dual layer tubes.



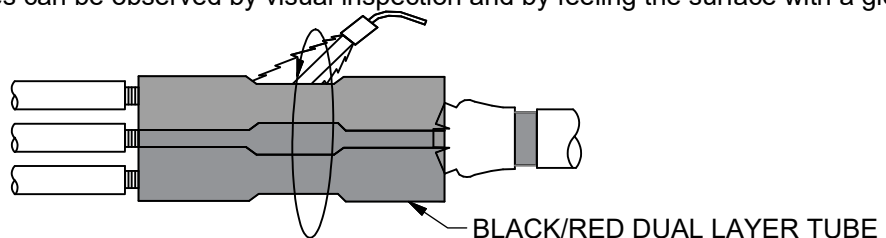
## 18. Apply Red Sealant

- Remove backing from red sealant.
- Using light tension, wrap sealant over the cable and butt against the red insulating tube as shown.
- Build the sealant to the level of the red insulating tube.



## 19. Position and Shrink Black/Red Dual Layer Tubes

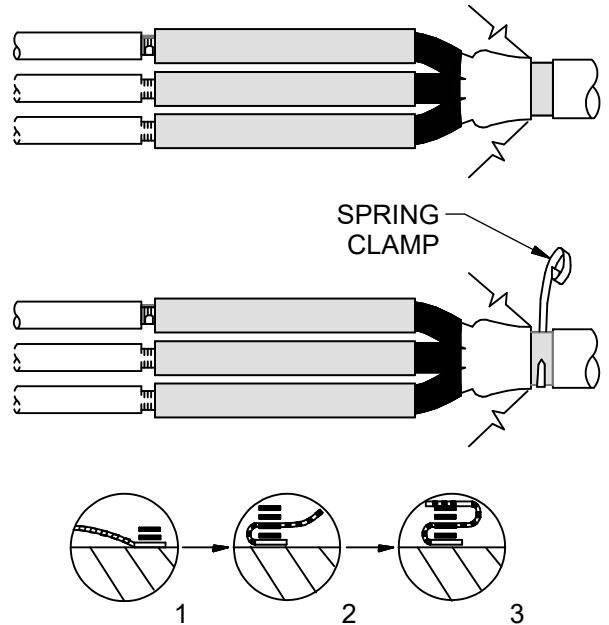
- Center the tubes over the red insulating tubes.
- Shrink in place using the method described in Step 16 except stop shrinking 4" from each end. Then shrink each end.
- After initial shrinking, heat the entire tubes for approximately one minute. The raised ridges should disappear. Absence of ridges can be observed by visual inspection and by feeling the surface with a gloved hand.



## 20. Install Ground Leads to PILC Cable

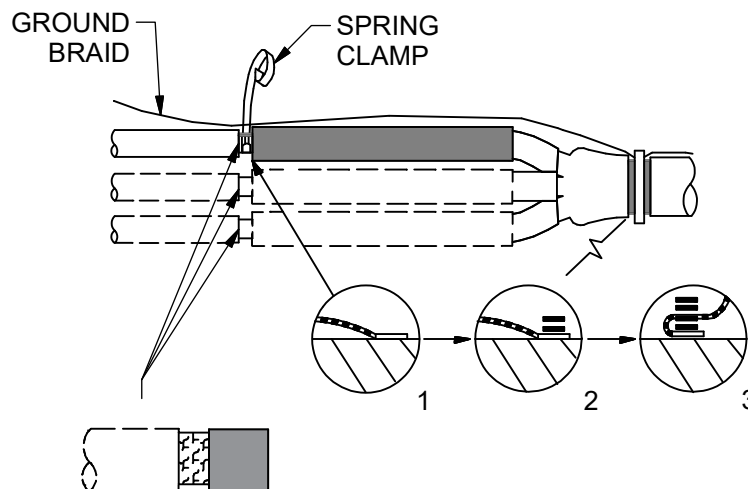
There are three long braids provided with this kit. One end of the braid has a short length of heat shrink tube installed next to a 2" wide solder block. This is the end of the braid which will be positioned over the jacket for external grounding.

- A. Wrap three layers of 2" wide copper mesh around the cleaned lead sheath on the 3/C PILC side of the joint. Tie off with a half hitch or equivalent knot.
- B. Lay three braids across the joint evenly spaced around the joint circumference so that the braids overlap the mesh and the solder block is positioned over the jacket and aligned with the cable jacket cutback. Temporarily tape the braids into position.
- C. (1) Wrap two turns of the LARGE spring clamp OVER the three braids and mesh. (2) Fold the long end of the braid back over the spring clamp and wrap two additional turns. (3) Fold long end one more time over the spring clamp over the braid. (The long end of the braid should be going across the splice at this time.)



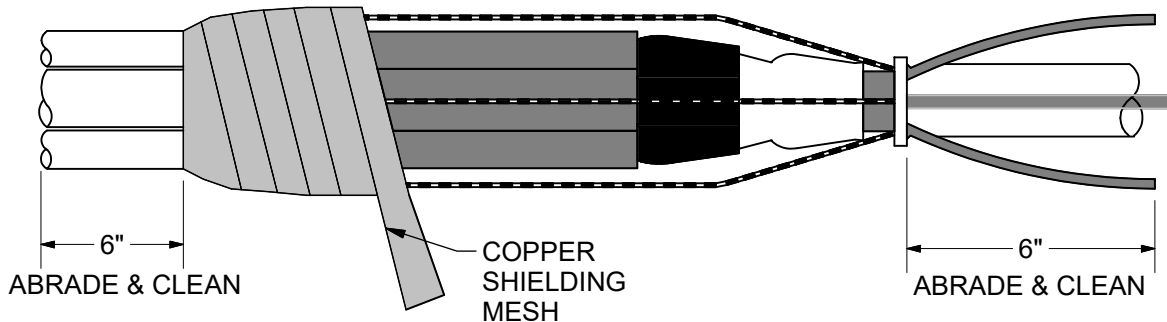
## 21. Install Ground Leads to Metallic Shields

- A. Wrap three layers of 2" wide copper mesh around the metallic shields of the solid dielectric cable and tie off with a half hitch or equivalent knot. (Wrap around flat strap, concentric wires or LC Shield.)
- B. (1) Lay braid directly over the mesh. (2) Wrap two turns of the SMALL spring clamp OVER the braid and mesh. (3) Fold back the braid over the spring clamp and complete wrapping the spring clamp over the braid. (Excess braid should be going across the splice at this time.) Excess braid may be cut off or left over the splice.
- C. Repeat this step for remaining phases until all three phases are completed.



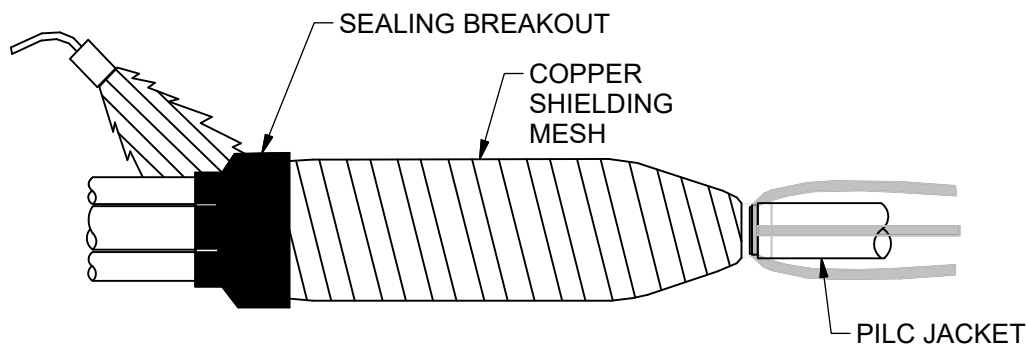
## 22. Apply Shielding Mesh

- Starting over the ground connections on the extruded solid dielectric cable side of the splice, wrap one half lapped layer of 2" wide shielding mesh across the splice and tie off to the PILC cable lead sheath.
- Abrade and solvent clean the cable jackets (or lead sheath) as shown.



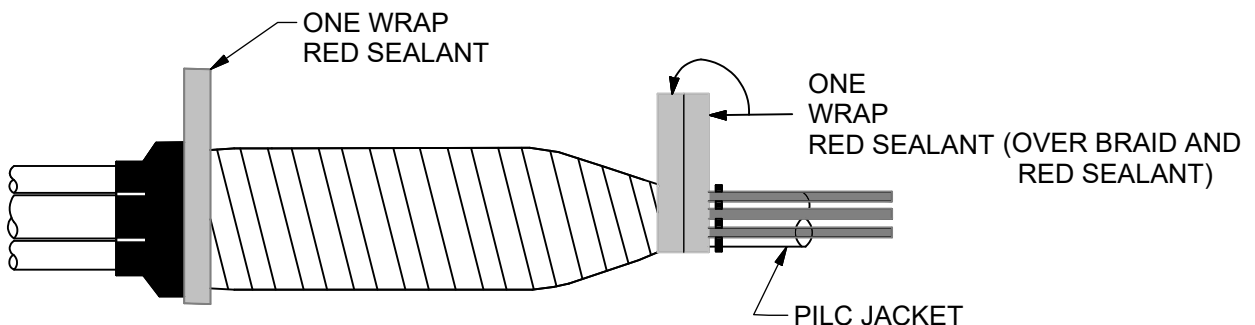
## 23. Position and Shrink Non-conductive Sealing Breakout

- Slide the breakout into position. Make sure that the full length of the fingers of the breakout are over the cable jackets and the body is extending over the splice.
- Shrink in place starting at the fingers and working toward the splice center.



## 24. Apply Red Sealant

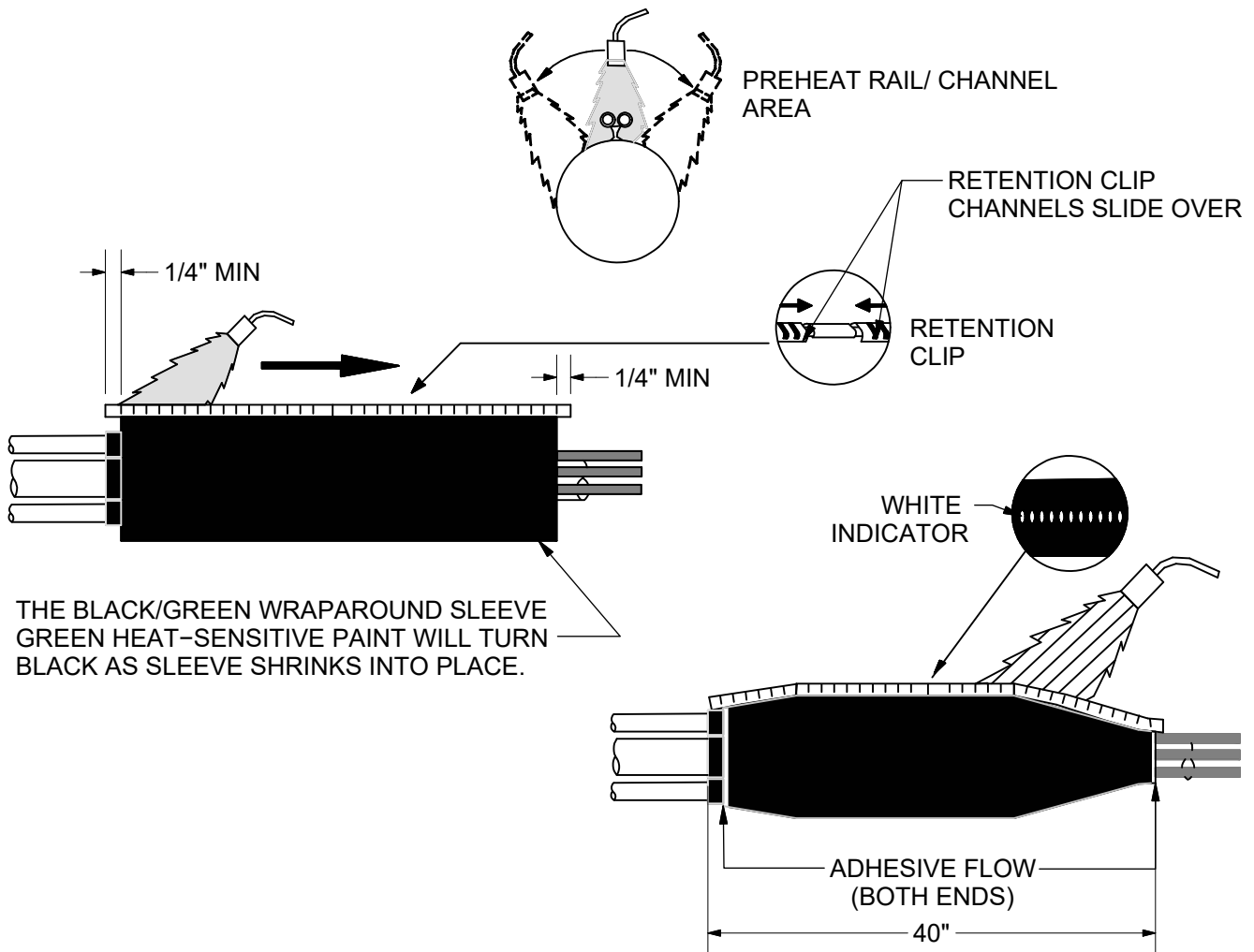
- Allow the breakout to cool sufficiently to touch before proceeding.
- Apply two single wraps of red sealant under the ground braids on the PILC cable side. Wraps should be side by side and butted up to the cable jacket cutback.
- Lay the braids down and press the solder blocked portion and the end of the heat shrink tubing into the red sealant.
- Apply two additional single wraps of red sealant over the braids and the first layers of red sealant.
- Apply one wrap of red sealant over the body of the breakout as shown.



25. Position and Shrink Wraparound Sleeve

- A. Remove or tape over all sharp points to prevent puncture of wraparound sleeve.
- B. Remove the backing from the wraparound sleeve and center sleeve over splice.
- C. Slide the metal retention clip onto the butted rails. Connect the channels by overlapping the retention clip as shown below.
- D. Channel(s) must overlap sleeve edges by 1/4" minimum.
- E. Preheat evenly along both sides of the rail/channel area until this area begins to shrink. (Critical Step)
- F. Begin shrinking at the center of the sleeve and work all the way around the sleeve and toward each end.
- G. Apply heat until the sleeve is completely shrunk and the green paint is completely converted to black.
- H. Post heat the entire length, concentrating on the metal channel area. The post heat should be for 30 seconds after the sleeve is completely shrunk. A white line should be visible in the channel gaps indicating sufficient heating.
- I. Look for adhesive flow at both ends of the sleeve.
- J. Allow the sleeve to cool before moving or placing in service.

The splice is now complete.



REV	DATE	ENG	DESCRIPTION
2	01/01/23	EJB	Converted to new format
1	05/25/07	EJB	



**UNDERGROUND CABLE SPLICE**  
 Trifurcating 3/C PILC to 3 1/C Extruded Solid Dielectric  
 Heat - Shrinkable

<b>41 43 22 **</b>
<b>35kV</b>
<b>10 of 10</b>

DCS #	PILC CABLE	SOLID DIELECTRIC CABLE
41 43 22 01	350 <sup>3</sup>	3-350 CNRP
41 43 22 02	800 <sup>3</sup>	3-750 FSRP

ITEM	STK / DCS #	DESCRIPTION	41 43 22 **	01	02
A	17 05 317	Splice-Cond., Trif., H.S., 350 kcmil & 750-800 kcmil		1	1
B	17 60 359	Sleeve-Cmpsn., 350kcmil Cu.		3	-
	17 60 504	Sleeve-Cmpsn., 800 kcmil to 750 kcmil Cu.		-	3
C	25 53 055	Tape-Plastic (RL)		1	1
	745	Op Code Splice 35 kV Heat Shrink		1	1

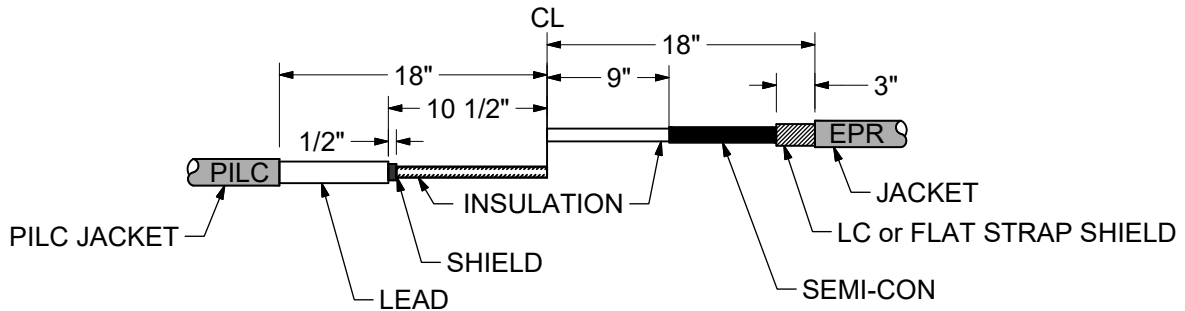
REV	DATE	ENG	DESCRIPTION
2	01/01/23	EJB	Converted to new format
1	05/25/07	EJB	

**INSTRUCTIONS:**

**1. HEAT SHRINK BASICS**

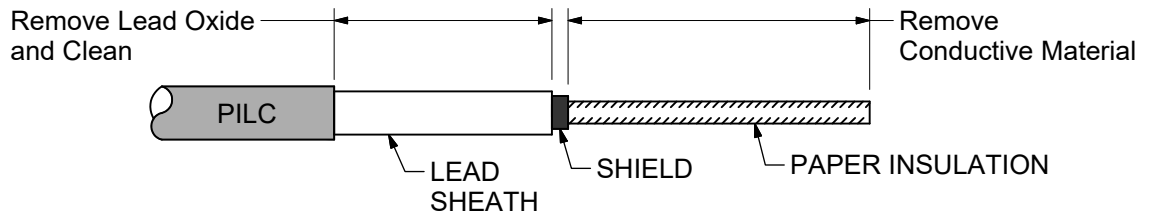
- A. Adjust the flame so that it is an overall 12 inch bushy flame.
- B. Apply outer 3 to 4 inch tip of the flame to heat-shrinkable material with a rapid brushing motion.
- C. Unless otherwise instructed, start shrinking tubes at the center working the flame around all sides of the tubes to apply uniform heat.
- D. Concentrate on heating the back of the tubes as well as the front of the tubes.
- E. If it is necessary to interrupt the shrinking process and the tubes cool, you must reheat prior to shrinking the next tube.
- F. Inspect all installed tubes. Reheat any flat spots or wrinkles, paying particular attention to the back of the splice.

**2. PREPARE CABLES**

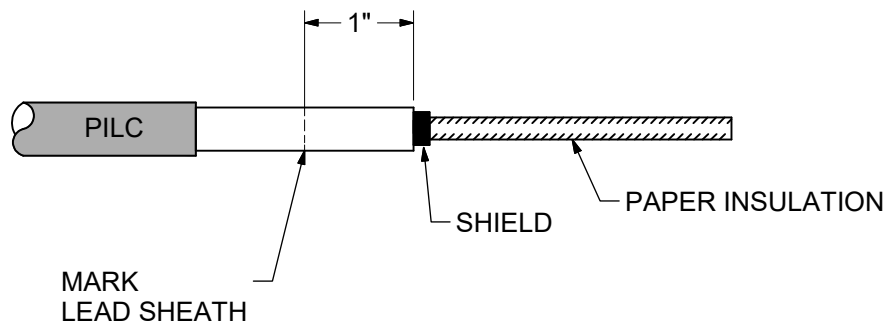


**3. PREPARE LEAD SHEATH AND PAPER INSULATION**

- A. Remove lead oxide from the lead sheath and clean with oil-free solvent.
- B. Remove conductive material from the paper insulation.  
Remove lead oxide from the lead sheath and clean with an approved solvent. Remove the lead sheath as shown.



**4. MARK LEAD SHEATH**

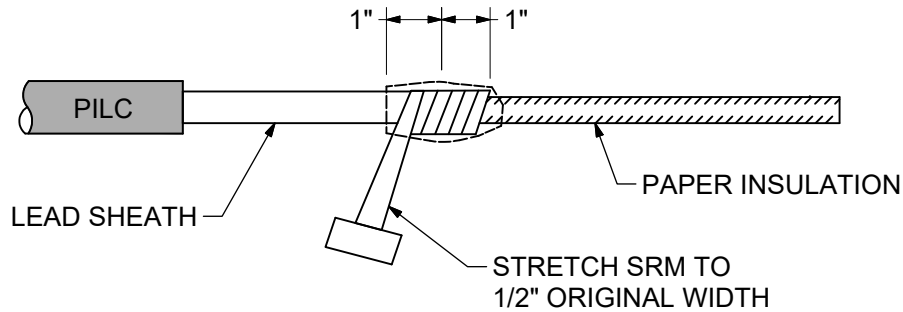


REV	DATE	ENG	DESCRIPTION
2	01/01/23	EJB	Converted to new format
1	04/19/2020	EJB	



## 5. APPLY STRESS RELIEF MATERIAL (SRM) AT LEAD SHEATH CUTBACK

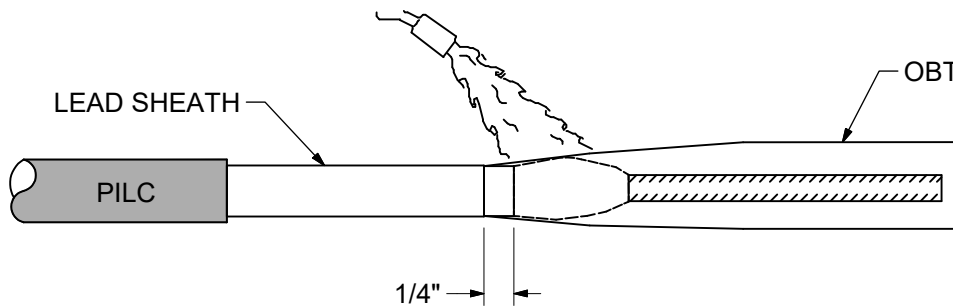
- A. Remove backing from one side of a long strip of SRM. Roll the SRM and remaining backing strip into a convenient size.
- B. Remove the remaining backing strip and tightly wrap SRM around the shield. Continue wrapping to the mark on the lead sheath, then back across the shield onto the paper insulation as shown.
- C. Apply a maximum thickness of 1/8" of SRM over the lead sheath to prevent excessive diameter buildup. Save the remaining SRM.



## 6. POSITION AND SHRINK OIL BARRIER TUBES (OBT)

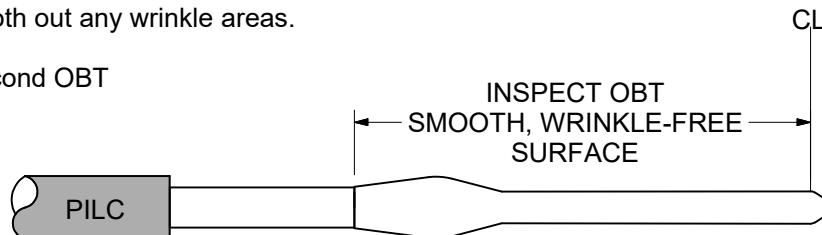
- A. Place the OBT over the PILC cable as shown.
- B. Shrink in place starting at the SRM. Work around the tube with a smooth brushing motion.

To achieve a smooth wrinkle free installation, use a reduced flame to install the thin walled OBT.



## 7. INSPECT THE OBT

- A. The OBT should have a smooth, wrinkle free surface after shrinking.
- B. Reheat to smooth out any wrinkle areas.
- C. Discard the second OBT

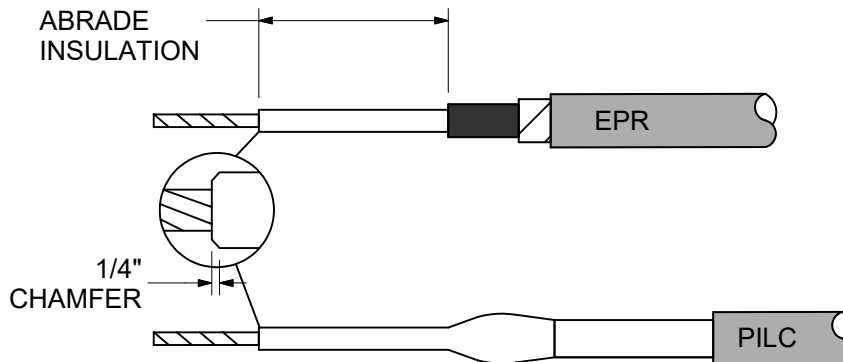


**8. REMOVE INSULATION FROM PILC AND EPR CABLES**

- A. Mark the insulation 1/2 the length of the connector plus 1/2" from the end of each cable.
- B. Cut off the insulation to the mark on each cable.

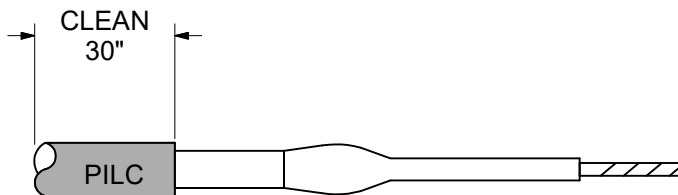
**9. ABRADE THE EPR INSULATION**

- A. Chamfer the insulations for 1/4".
- B. Clean the EPR insulation



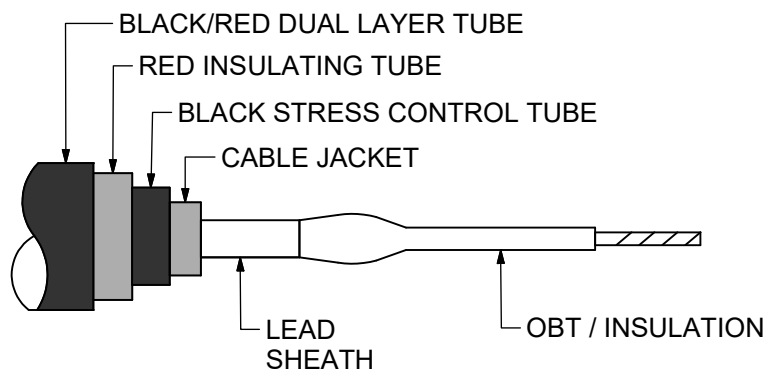
**10. CLEAN THE PILC CABLE**

- A. Clean the PILC cable for the length of the nested tubes.



**11. PLACE THE NESTED TUBES OVER THE PILC CABLE**

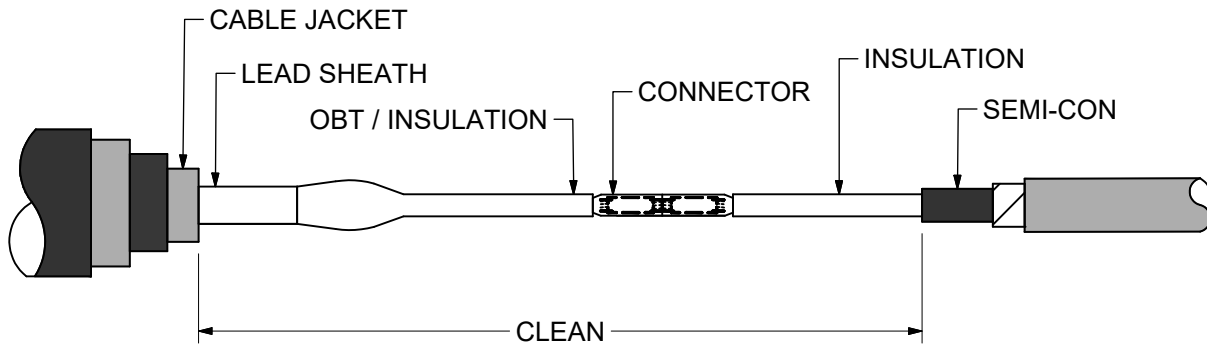
- A. Place nested tubes over PILC cables as shown
- B. Protect tubes from end of conductor as they are placed over cable end.



REV	DATE	ENG	DESCRIPTION
2	01/01/23	EJB	Converted to new format
1	04/19/2020	EJB	

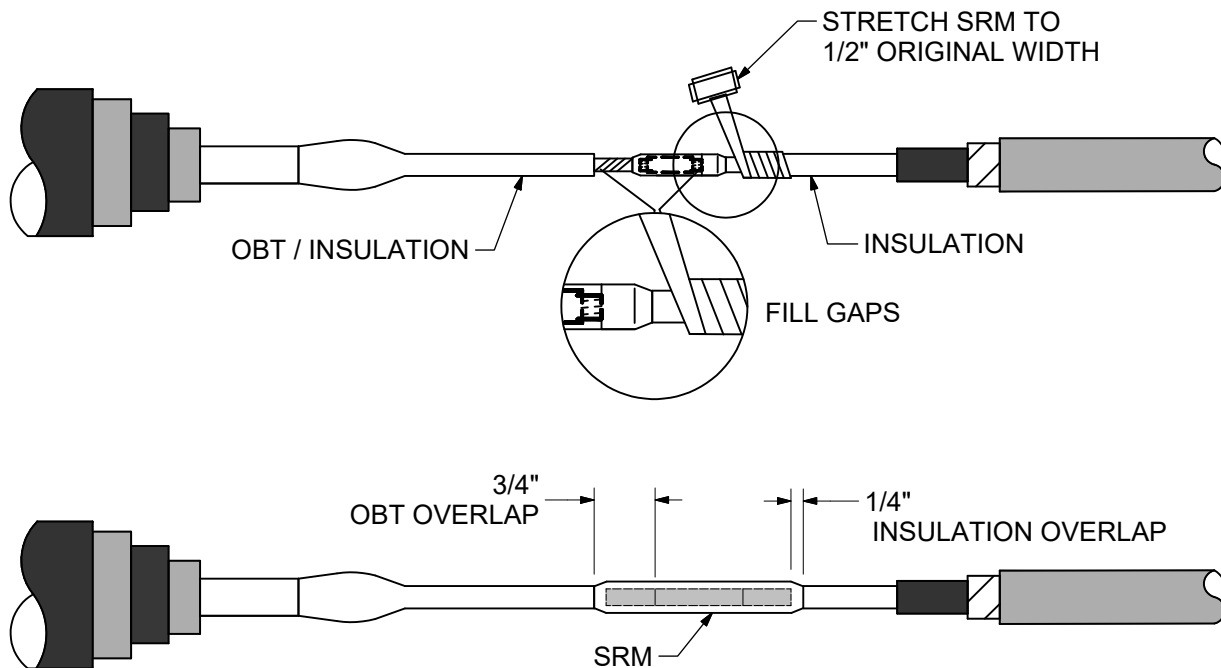
## 12. INSTALL THE CONNECTOR

- A. Slide the cables into the connector and crimp the connector.
- B. Make sure that the crimps are smooth. Deburr the connector if necessary.
- C. Clean the insulation and OBT's.



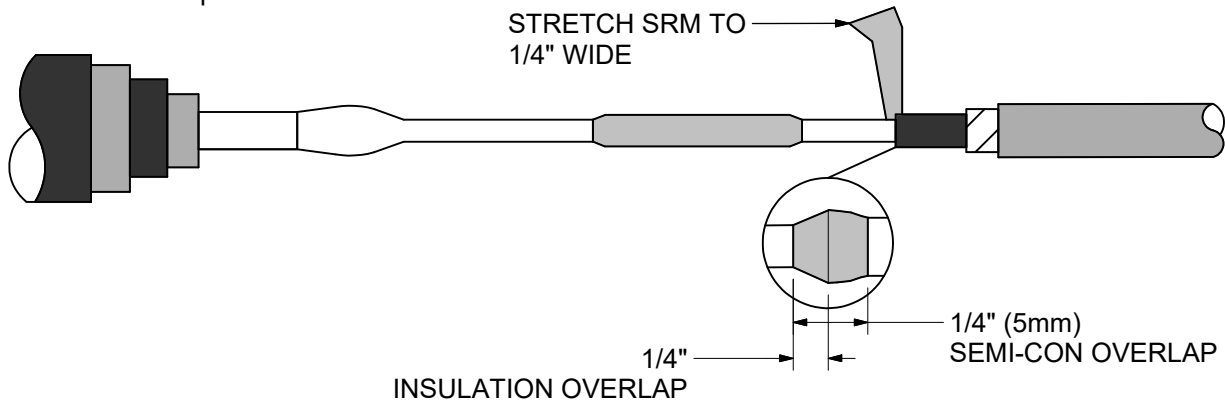
## 13. APPLY SRM OVER CONNECTOR

- A. Remove backing from one side of a long strip of SRM, roll the SRM and remaining backing strip into a convenient size.
- B. While removing the remaining backing strip, tightly wrap the SRM around the connector and exposed conductor. Be sure to fill the gaps and low spots around the connector.
- C. Continue to wrap the SRM onto the insulation as shown.

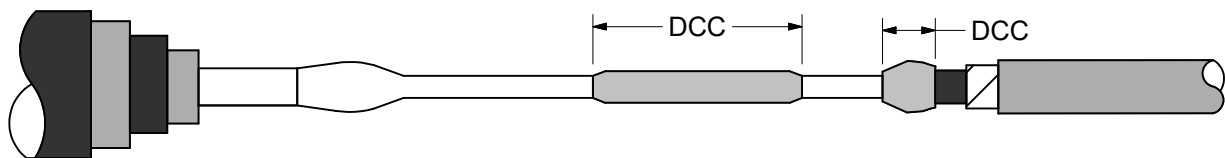


## 14. APPLY SRM AND DISCHARGE CONTROL COMPOUND (DCC) AT SEMICON CUTBACK

- A. Remove the backing from the short anglecut piece of SRM.
- B. Place the tip of the SRM at the semicon cutback and tightly wrap to fill the semicon step.
- C. Overlap the semicon and the insulation as shown. Taper the SRM down to meet the insulation.
- D. Snip open the end of the DCC ampule and apply a thin film of compound on the SRM over the connector and the semi-con step.

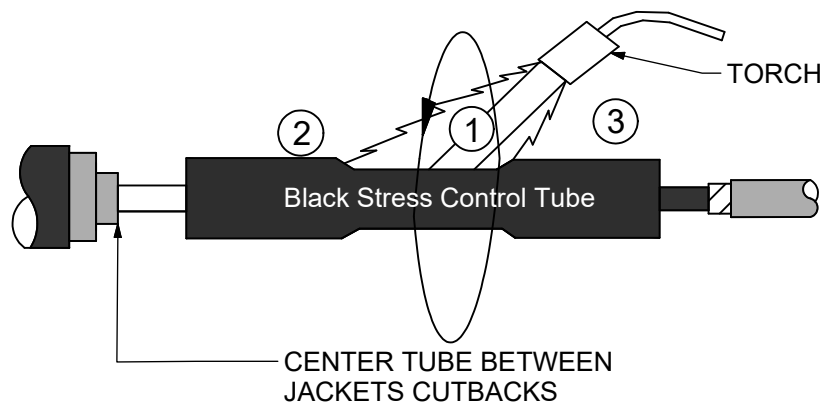


APPLY THIN FILM OF DCC OVER SURFACE OF INSTALLED SRM



## 15. POSITION AND SHRINK THE BLACK STRESS CONTROL TUBE

- A. Center the tube over the splice.
- B. Begin shrinking at the center (1) of the tube, working the torch around all sides of the tube.
- C. After the center portion shrinks, work towards one end (2) and then to the opposite end (3).
- D. Do not point the flame at the cable semi-con.
- E. The rings of the SRM wraps may be visible as the tubing is shrunk.
- F. Post heat the connector area until the tube surface is smooth.



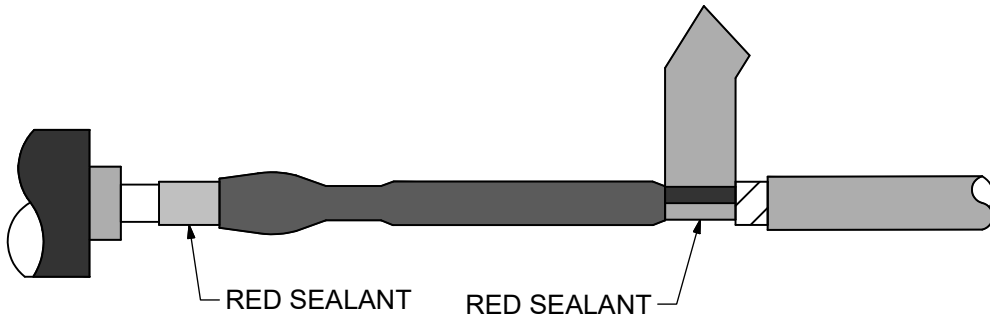
## 16. POSITION AND SHRINK THE RED INSULATING TUBE

- A. Center red insulating tube over black stress control tube.
- B. Shrink in place using the same method as 15.
- C. Do not allow the red insulating tube to cool before applying red sealant and installing the black/red dual layer tube.



## 17. APPLY RED SEALANT

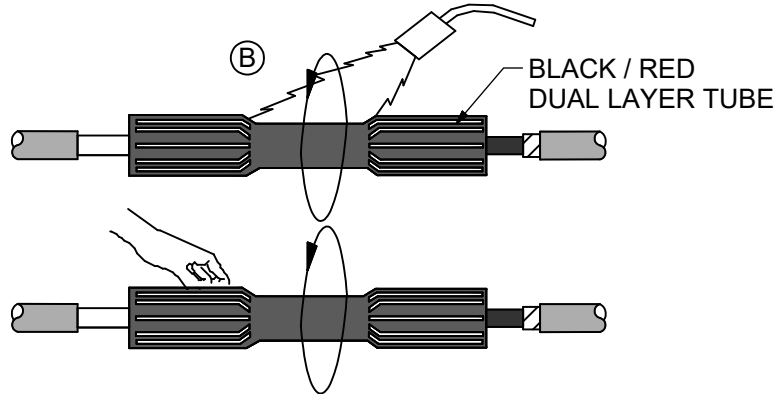
- A. Remove backing from sealant.
- B. Using light tension, wrap sealant over the cable and butt against the red insulating tube as shown.
- C. Build the sealant to the level of the red insulating tube.



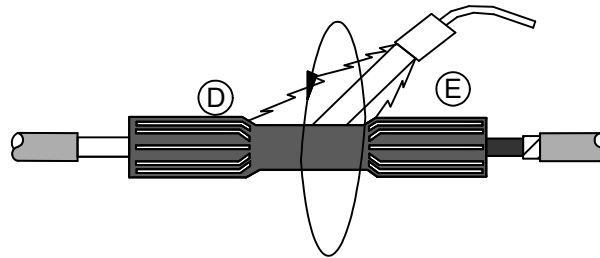
## 18. POSITION AND SHRINK THE BLACK/RED DUAL LAYER TUBE

- A. Center Tube Over Joint
- B. Begin shrinking in center of tube, working torch around all sides of the tube. Pay particular attention to the back and underside of the tube.
- C. Before continuing, gently twist the unshrunk end of the tube to feel for resistance to movement in center indicating the center is shrunk.

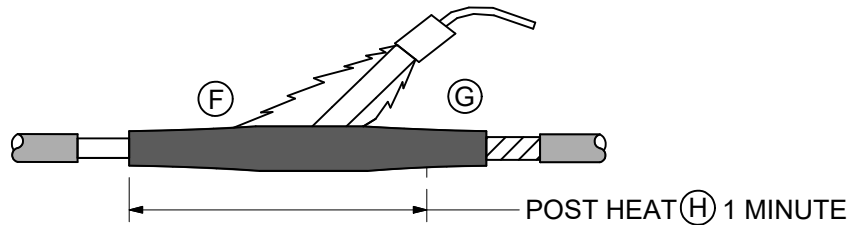
- D. Shrink from the center toward one end and stop about 5" from the end of the tube.
- E. Return to the center and shrink toward the other end, again stopping about 5" from the tube end.



Ⓒ TWIST GENTLY TO CHECK FOR RESISTANCE TO MOVEMENT IN CENTER

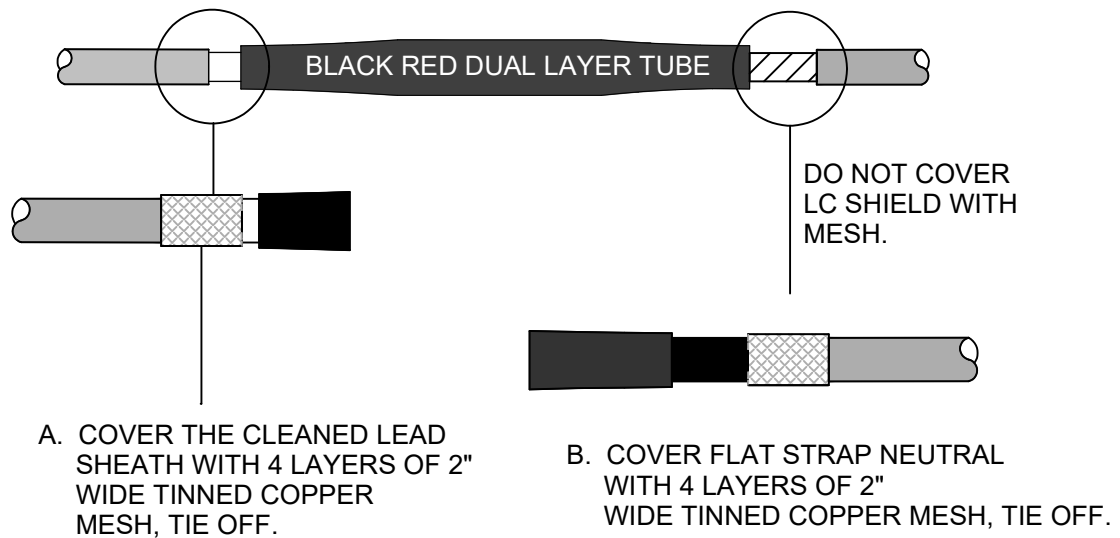


- F. Go back to first end and shrink the remaining 5" of tube.
- G. Go back to second end and shrink the remaining 5" of tube.
- H. After completing these steps, heat the entire tube for approximately 1 minute.
- I. When completely shrunk down, the raised ridges should disappear.



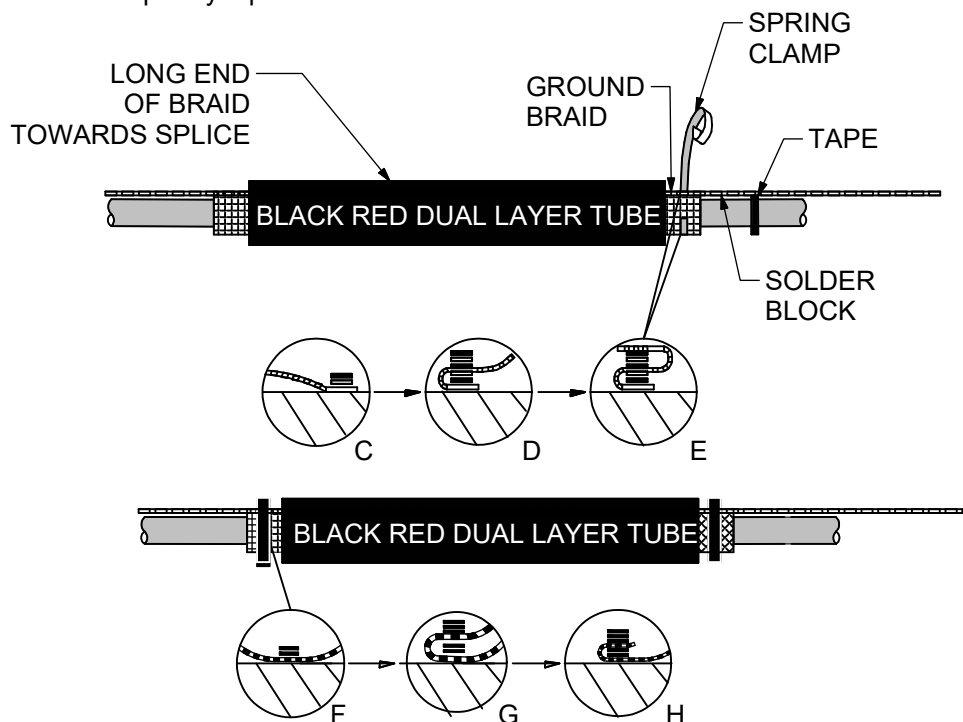
Ⓘ INSPECT TUBE. ABSENCE OF RAISED RIDGES CAN BE OBSERVED BY VISUAL INSPECTION AND BY FEELING THE SURFACE WITH A GLOVED HAND.

## 19. INSTALL MESH ON THE CABLES



## 20. INSTALL THE GROUND BRAID AND THE GROUND SPRINGS

- A. Lay the braid across the splice with the inner edge of the solder block aligned with the cable jacket cutback.
- B. The shortest length of braid from the solder block should extend away from the splice. Tape the braid to the cable jacket to temporarily keep in place.
- C. Starting at the solderblocked end, wrap two turns of the spring clamp over the braid and mesh or metallic shield.
- D. Fold the long side of the braid back over the spring clamp and wrap the remainder of the clamp over the braid.
- E. Fold the braid back over the clamp and route across the splice.
- F. Wrap two turns of the second spring clamp over the braid and the mesh covered lead sheath.
- G. Fold the braid back over the clamp and wrap the remainder of the clamp over the braid
- H. If no external ground connection, cut off the short length of braid at the solder block.
- I. Remove the temporary tape.

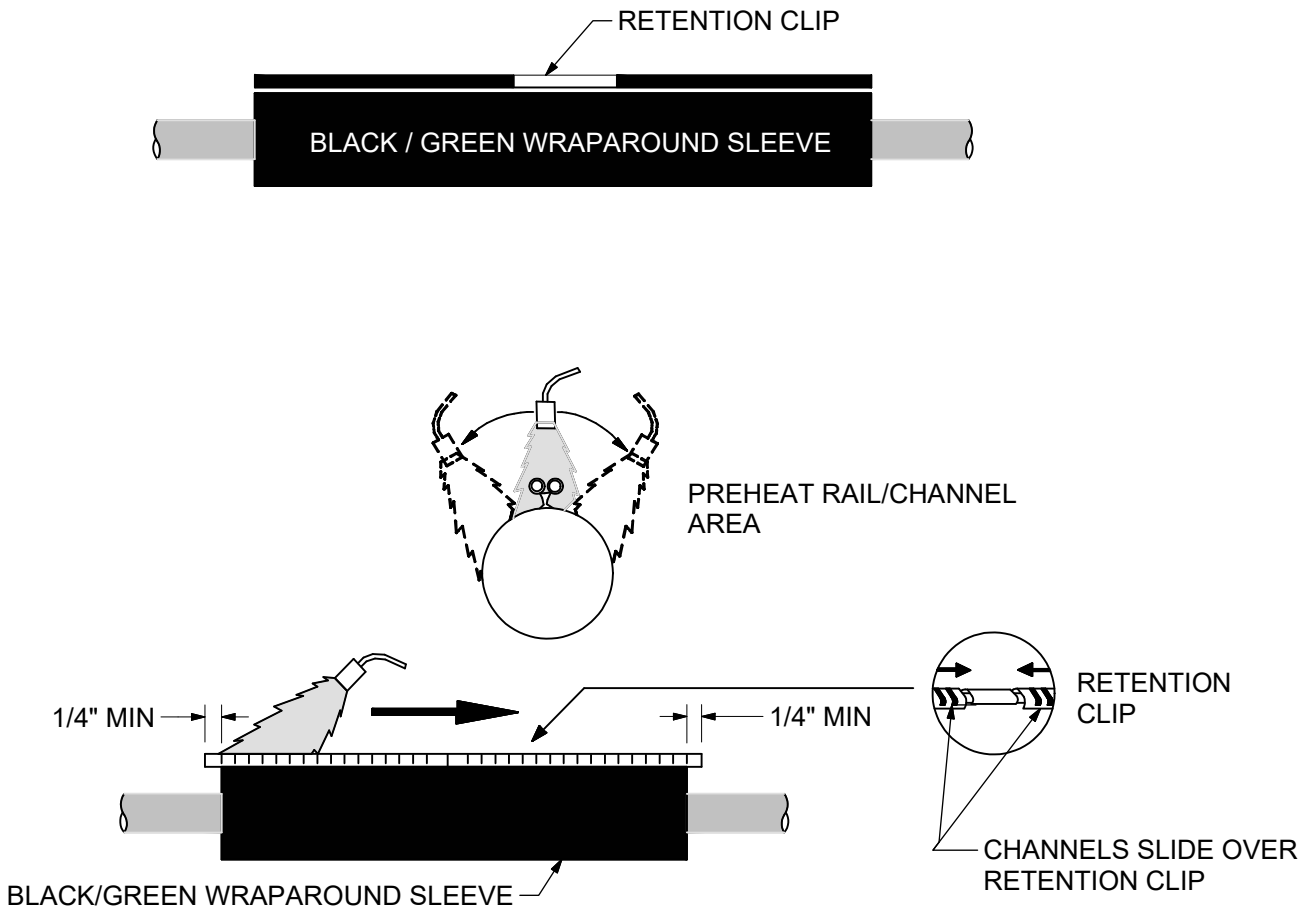






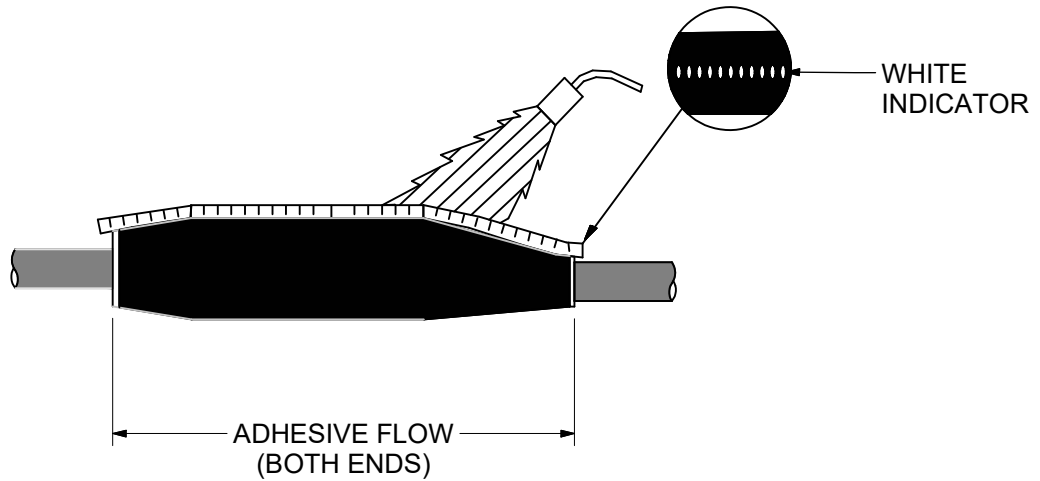
## 23. POSITION AND SHRINK WRAPAROUND SLEEVE

- A. Remove or tape over all sharp points to prevent puncture of wraparound sleeve.
- B. Remove the backing from the wraparound sleeve and center sleeve over splice.
- C. Slide the metal retention clip onto the butted rails. Connect the channels by overlapping the retention clip as shown below.
- D. Channel(s) must overlap sleeve edges by 1/4" minimum.
- E. Preheat evenly along both sides of the rail/channel area until this area begins to shrink. (Critical Step).
- F. Begin shrinking at the center of the sleeve and work all the way around the sleeve and toward each end.
- G. Apply heat until the sleeve is completely shrunk and the green paint is completely converted to black.
- H. Post heat the entire length, concentrating on the metal channel area. The post heat should be for 30 seconds after the sleeve is completely shrunk. A white line should be visible in the channel gaps indicating sufficient heating.
- I. Look for adhesive flow at both ends of the sleeve.
- J. Allow the sleeve to cool before moving or placing in service.



NOTE: GREEN HEAT-SENSITIVE PAINT WILL TURN BLACK AS SLEEVE SHRINKS INTO PLACE.

REV	DATE	ENG	DESCRIPTION
2	01/01/23	EJB	Converted to new format
1	04/19/2020	EJB	



**THE SPLICE IS NOW COMPLETE**

DCS #	PILC CABLE	TO	SOLID DIELECTRIC CABLE
41 44 21 01	350 <sup>1</sup>		1-350 CNRP
41 33 22 02	750 <sup>1</sup>		1-750 FSRP

ITEM	STK / DCS #	DESCRIPTION	41 44 21 **	01	02
A	17 05 481	Splice-Cond., 1C ., H.S., 350 kcmil & 750-800 kcmil		1	1
B	17 60 359	Sleeve-Cmpsn., 350 kcmil Cu.		1	-
	17 60 360	Sleeve-Cmpsn., 750 kcmil Cu.		-	1
C	25 53 055	Tape-Plastic ( RL )		1	1
	425	Op Code Splice Non Lead Str. 35 kV		1	1

**INSTRUCTIONS:**

Keep the cable clean at all times, but do not use solvent on the semi-conductive jacket.

1. There must be a 10 inch overlap of the cables. Wipe the cable clean 2 feet on each side.

2. Saw cut and prepare both cables according to the dimensions shown. Bevel the edge of the cable insulation at 45° angle. Do not exceed 1/8". Cable "A" dimensions are different from cable "B" dimensions.

3. If both cables are jacketed, slide the cold shrink sleeve(s) over one of the cables.

4. Apply one-half lapped layer of brightly colored vinyl tape for the distance shown over the semi-conductive jacket of cable A. Begin tape 1/4" on the insulation of the cable. Apply 2 layers of brightly colored vinyl tape on the end of the conductor of cable A.

5. Apply silicone grease over the cable insulation and vinyl tape.

6. Slide the splice end caps onto each cable until butted against the concentric neutral wires.

7. Slide the splice body onto cable A. Do not slide past the end of the vinyl tape.

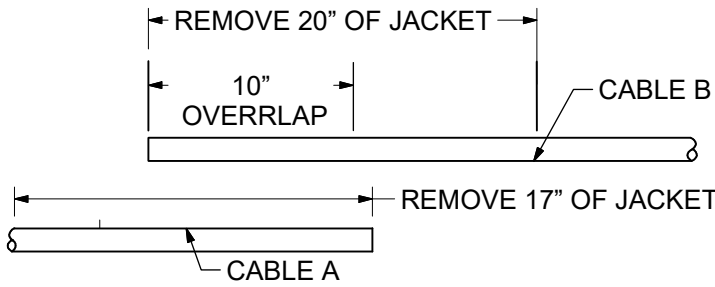
8. Remove the previously applied vinyl tape from the end of conductor of cable A.

9. Prior to installing the connector, clean the exposed conductor with a stainless steel wire brush. Some splice kits may contain a small disposable stainless steel wire brush, if so, it should be used. If there is no wire brush in the kit use one of the stocked stainless steel wire brushes. Crimp the connector onto the cable.

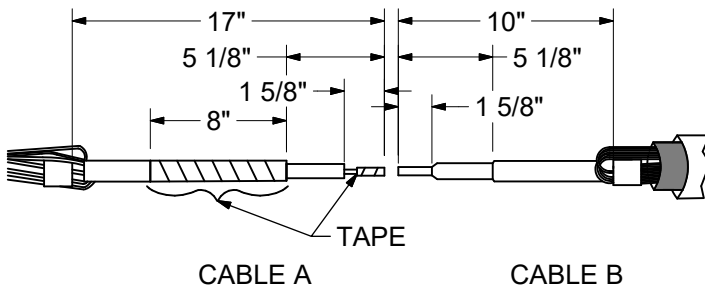
10. Slide the splice body into final position over connector. A small area of insulation should be left exposed at the ends of splice body as shown.

11. Remove the remaining vinyl tape from cable A.

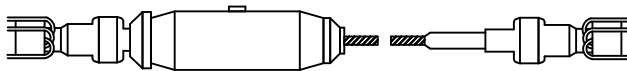
12. Slide end caps onto the splice body. Two locking grooves exist on the splice body. Insure that end caps are fully seated. There should be no visible gap between the cap and splice body.



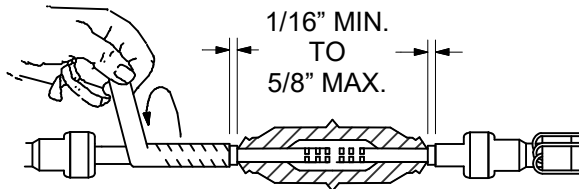
**STEP 1**



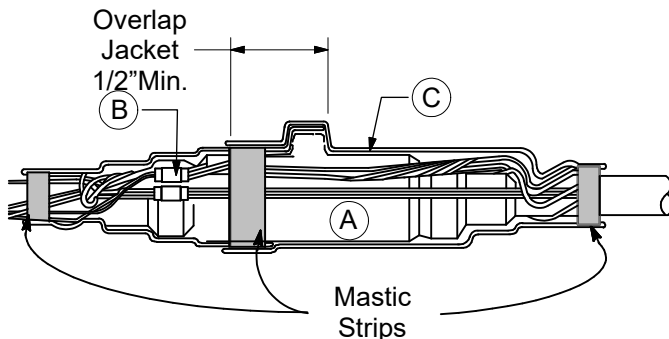
**STEP 2 - 4**



**STEP 5 - 6**



**STEP 7 - 11**



**STEP 12 - 15**

REV	DATE	ENG	DESCRIPTION
2	01/01/23	EJB	Converted to new format
1	10/21/10	EJB	



# UNDERGROUND CABLE SPLICE

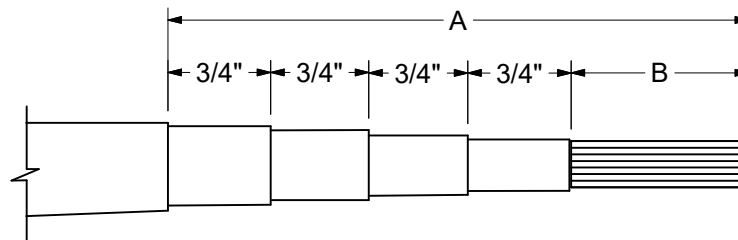
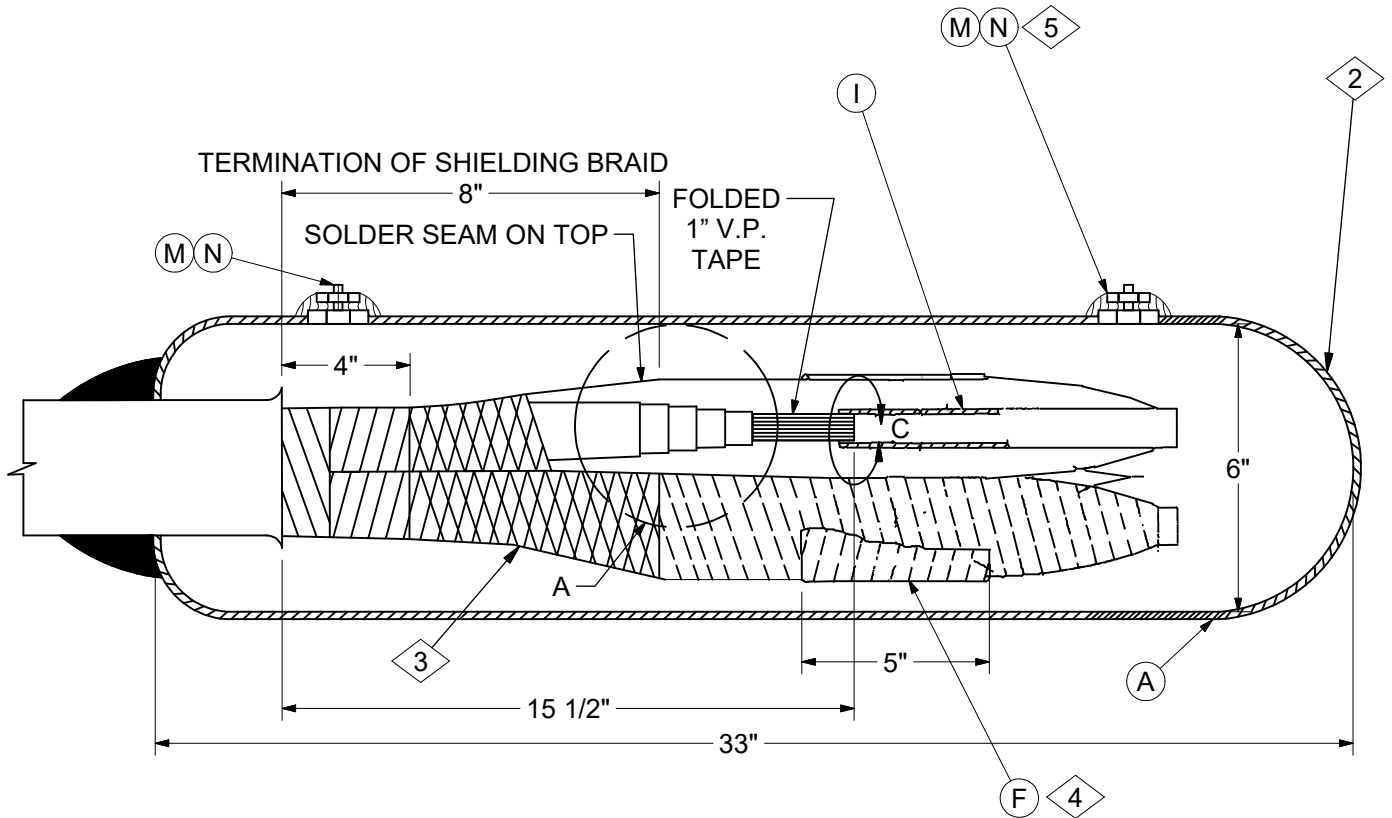
PREMOLDED - 3M  
1/0, CNR, P

41 44 30 03
35 kV
2 of 2

13. Connect the concentrics with three #4 sleeves on cable "A" side. Place 5 and 6 wire bundles into separate sleeves. Snug the sleeves and wires tightly against the splice and the cable. In manholes, bring the remaining concentric neutral strands outside of the splice cover. Attach a #2 copper bond wire to the neutral wires using a two bolt clamp (17 54 140). Attach the other end of the bond wire to the system ground.
  
14. For jacketed cable(s), wrap a layer of mastic at the end of each cable jacket. Slide the first cold shrink sleeve over the splice with the end of the sleeve overlapping the opposite cable jacket cut off (or mastic strip) by two inches. Shrink the sleeve down.
  
15. Wrap one layer of mastic at the inner end of the shrunken sleeve. Slide the second sleeve over the splice and overlap the first sleeve by 1/2 inch minimum. Shrink the second sleeve down.

	ITEM	STK / DCS #	DESCRIPTION	41 44 30 **	03
	A	17 05 230	Splice-Straight, 1/0 Al. 35 kV		1
	B	17 60 103	Sleeve-Compression, #4 Copper		3
@	C	17 55 443	Sleeve-Cold Shrink, Sealing, 2 Pieces		1

REV	DATE	ENG	DESCRIPTION
2	01/01/23	EJB	Converted to new format
1	10/21/10	EJB	



**DETAIL A**

**CONSTRUCTION NOTE(s):**

1. Shielded joint shown. For belted joint, omit shielding braid.
2. Place joint in position so that the end cap of the joint is higher.
3. Shielding braid to be butt wrapped and soldered in a line along top and to the cable shielding. Avoid openings between the wrapping.
4. 3 Layers 1" v.p. tape over all three conductors
5. 1/8" x 1/2" Bushing soldered in sleeve

REV	DATE	ENG	DESCRIPTION
2	01/01/23	EJB	Converted to new format
1	03/30/11	EJB	



# UNDERGROUND CABLE SPLICE

Hot Test Cap  
350 kcmil or 500 kcmil 3 Cond. Lead Cable (Belted or Shielded)

<b>41 46 11 **</b>
<b>35kV</b>
<b>2 of 2</b>

DCS #	Cable Size	L Joint to Stepping A	Circumference Over Insulation C	Length of Bare Copper B
41 46 11 01	350 kcmil	4-3/4"	7-1/2"	1-3/4"
41 46 11 02	500 kcmil	5"	8"	2"

ITEM	STK / DCS #	DESCRIPTION	41 46 11 **	01	02
A	12 53 025	Sleeve – Lead, 6" x 34"		1	1
B	22 02 282	Solder – Wiping (Lb.)		12	12
C	22 02 273	Solder – 50 – 50 (Lb.)		3	3
D	22 02 276	Solder – String, 1/4" (Lb.)		1	1
E	22 02 255	Solder – Paste (Cn.)		1	1
F	25 53 063	Tape – V.P., 1" x 4 Yd. (RI.)		1	1
G	18 66 101	Braid – Copper Mesh, 1" x 15' (RI.)		3	3
H	31 51 003	Compound – Insul. Oil (GE219)		4	4
I	25 52 055	Tube – Fiber, 3/4" I.D. x 9"		3	-
	12 51 197	Conduit – PVC, Sch. 40, 1" x 10', Cut to Three 9" Length Tubes		-	1
J	31 53 007	Stearine (Ea.)		1	1
K	25 53 103	Tape – 4" Plastic x 160' (RI.)		1	1
L	22 05 213	Cloth – Sanding, 1 1/2" W (Ft.)		2	2
M	19 11 094	Bushing – 1/8" x 1/2"		2	2
N	19 11 015	Plug – Pipe, 1/8"		2	2
	731	Op Code Test Cap 35 kV		1	1

## DISTRIBUTION CONSTRUCTION STANDARDS

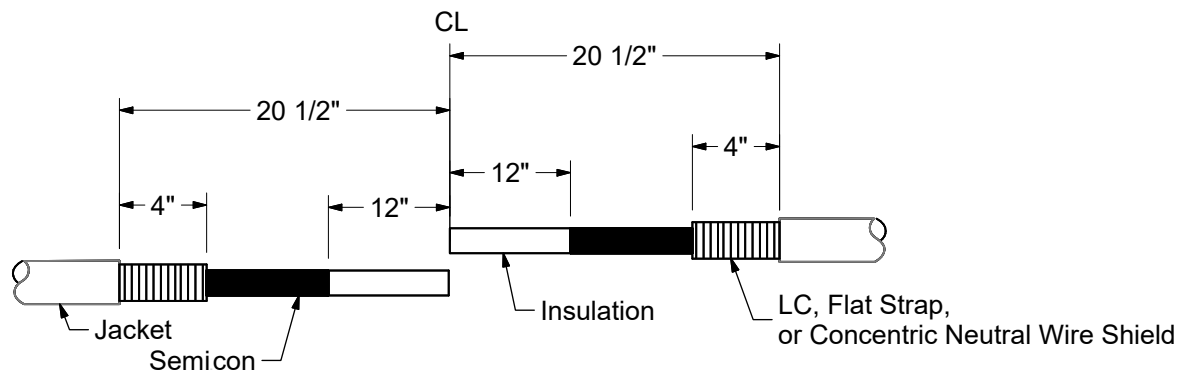
REV	DATE	ENG	DESCRIPTION
2	01/01/23	EJB	Converted to new format
1	03/30/11	EJB	

## INSTRUCTIONS:

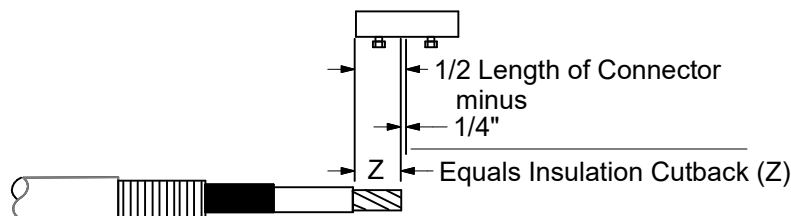
### 1. HEAT SHRINK BASICS

- Adjust the flame so that it is an overall 12–inch bushy flame.
- Apply outer 3– to 4–inch tip of the flame to heat–shrinkable material with a rapid brushing motion.
- Unless otherwise instructed, start shrinking tubes at the center, working the flame around all sides of the tubes to apply uniform heat.
- Concentrate on heating the back of the tubes as well as the front of the tubes.
- If it is necessary to interrupt the shrinking process and the tubes cool, you must reheat prior to shrinking the next tube.
- Inspect all installed tubes. Reheat any flat spots or wrinkles, paying particular attention to the back of the splice.
- A 2 inch diameter torch head (Stk. #85 36 326) is recommended to properly shrink the splice.

### 2. PREPARE CABLE

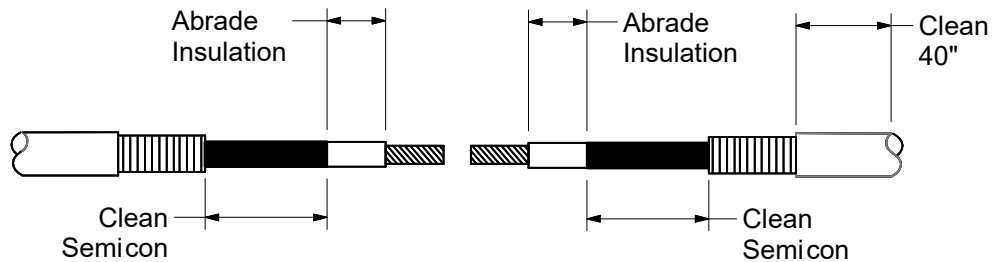


- Make sure that the cables to be joined are straight and level.
- Overlap the two cables 8" and cut at the centerline.
- Remove the cable jacket and metallic shield as shown above.
- Secure end of metallic shield with copper foil tape provided.
- Remove semicon as shown above.
  - Carefully score the semicon with a straight, fixed blade. Do not nick or cut the insulation!
  - Apply heat to the semicon while removing strips with a pliers. Keep the semicon hot for a clean separation between the semicon and the insulation.
  - Use a round file to smooth out the semicon cut off.



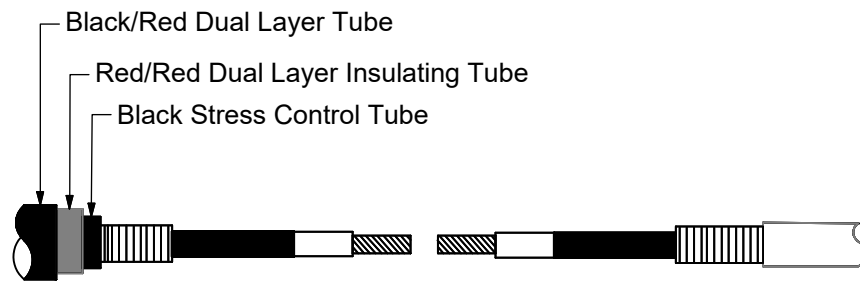
- Remove insulation as shown above. The insulation cut backs should equal 1/2 the connector length minus 1/4"

### 3. ABRABE THE INSULATION AND CLEAN THE CABLES



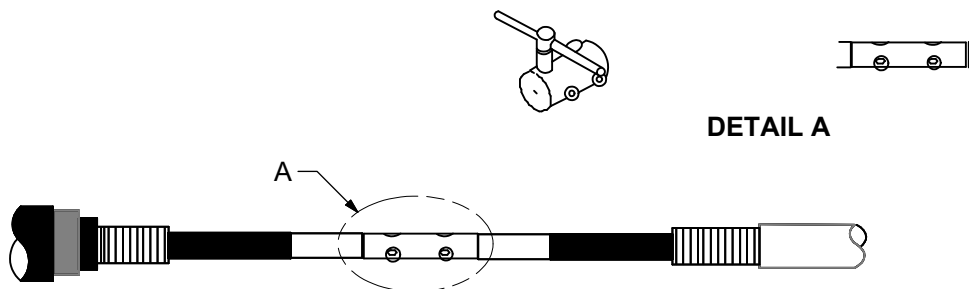
- Abrade and clean insulation (120 Grit nonconductive sanding tape works well) to remove imbedded semicon and smooth out the surface.
- Clean cable jacket as shown.
- It is very important that the cable insulation is clean, smooth, and free of nicks and cuts. Damaged or dirty insulation will cause the splice to fail!

### 4. PLACE NESTED TUBES OVER THE CABLE



- Protect the tubes from the end of the conductor by placing a plastic tube storage bag over one of the cable ends.
- Slide the tubes over the plastic bag.

### 5. INSTALL CONNECTOR & APPLY FILLER

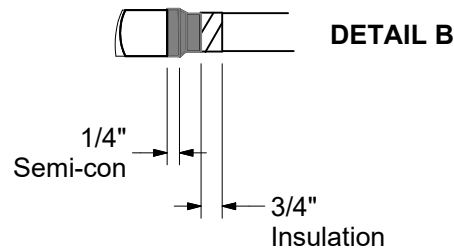
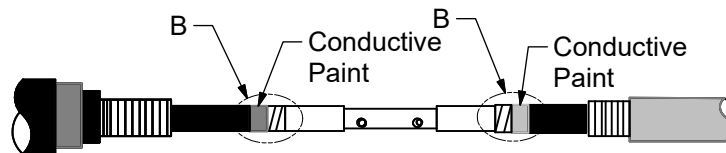
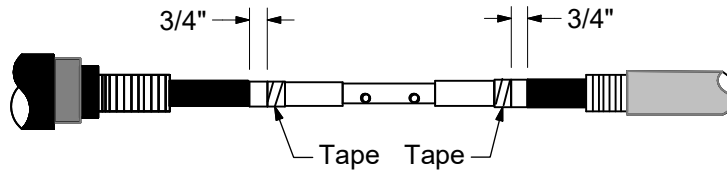


- Fit conductors into connector so that connector ends line up with the insulation.
- Make sure that no gaps are left between the connector and insulation.
- “Hand tighten” each bolt. Then, using a wrench, tighten each bolt an additional 1/2 turn.
- Continue to tighten each bolt until the head shears off.
- Apply filler over the sheared bolts to obtain a smooth finish.

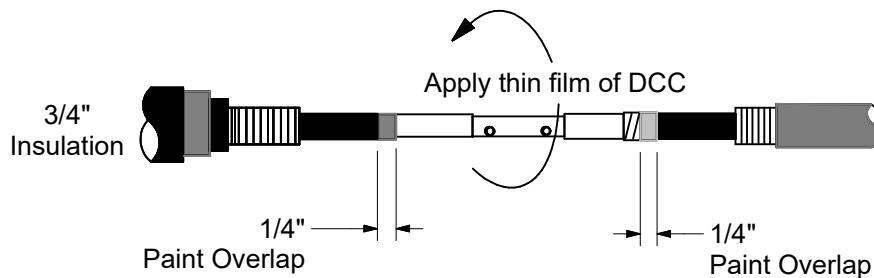


## 6. APPLY TAPE AND CONDUCTIVE PAINT

- Apply tape (adhesive side up) on the insulation 3/4" from the semicon cutback. Repeat on the other cable.
- Shake the conductive paint bottle for 30 seconds. Apply the paint onto the 3/4" of insulation and overlap the semicon shield by 1/4". Repeat on the other cable.

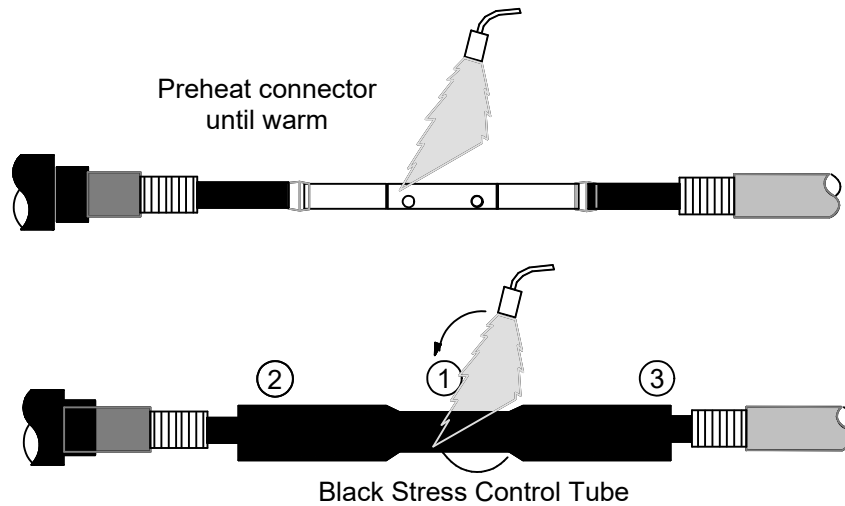


## 7. APPLY THE DISCHARGE CONTROL COMPOUND (DCC)



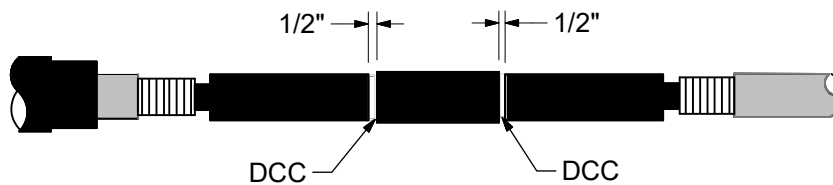
- Apply a thin layer of DCC to the surface of the insulation and the connector. Overlap the conductive paint by 1/4".

## 8. PREHEAT CONNECTOR; POSITION AND SHRINK BLACK STRESS CONTROL TUBE



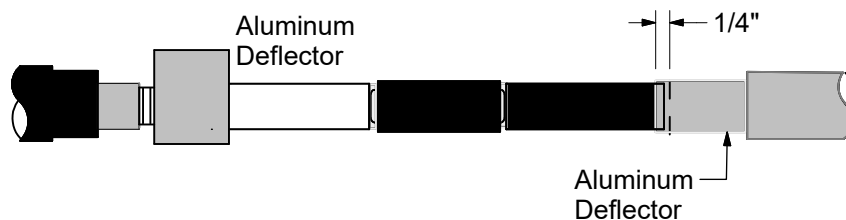
- Preheat the connector for approximately 1 minute or until warm.
- Center the black stress control tube over the splice.
- Begin shrinking at the center of the tube (1). Work the torch with a smooth brushing motion around the tube.
- After the center portion shrinks, work the torch toward one end (2) and then to the other end (3). Apply sufficient heat to ensure complete shrinkage as indicated by a smooth profile. Do not point the flame directly at the semi-con layer

## 9. APPLY DCC TO MATTE SURFACE



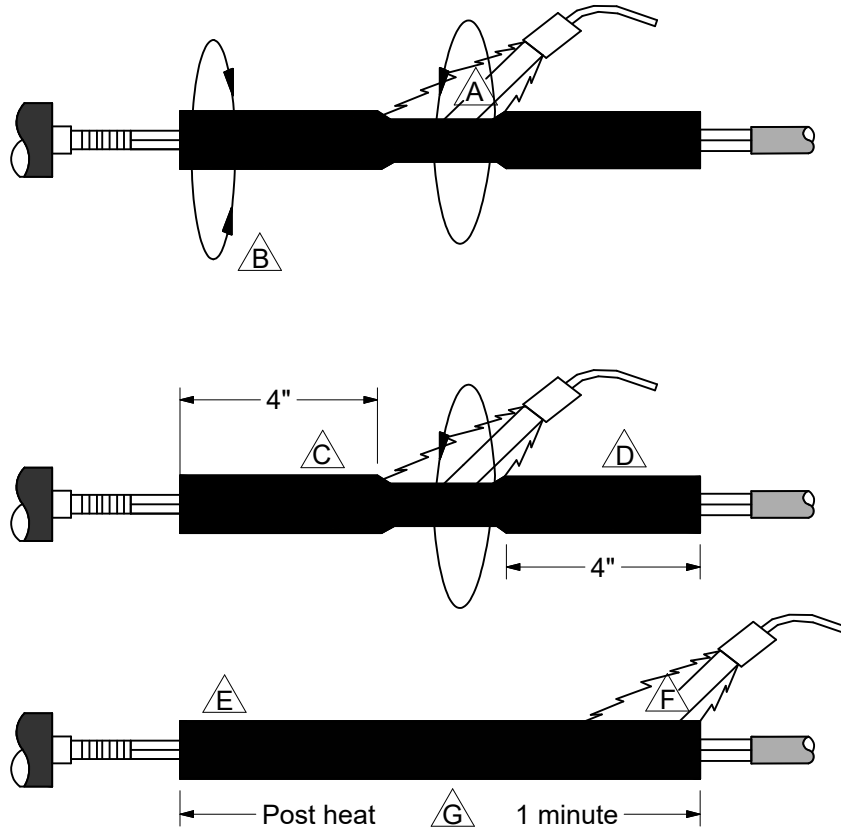
- Apply a thin film of DCC approximately 1/2" width around the edges of the matte surface in the center of the stress control tube.

## 10. INSTALL ALUMINUM DEFLECTORS



- Remove the backing and wrap the aluminum deflectors 1/4" onto the black stress control tube and over the shielding as shown.

11. POSITION THE RED/RED DUAL LAYER INSULATING TUBE AND SHRINK IN PLACE



**A.** Center the tube over the joint. Begin shrinking in the center of the tube. Work the torch around all sides particularly the back and underside of the tube.

**B.** Before continuing, gently twist the unshrunk end of the tube. Feel for resistance to movement in the center which would indicate that the center is shrunk.

**C.** Shrink from the center toward one end and stop about 4" from the end of the tube.

**D.** Return to the center and shrink toward the other end of the tube stopping 4" from the end.

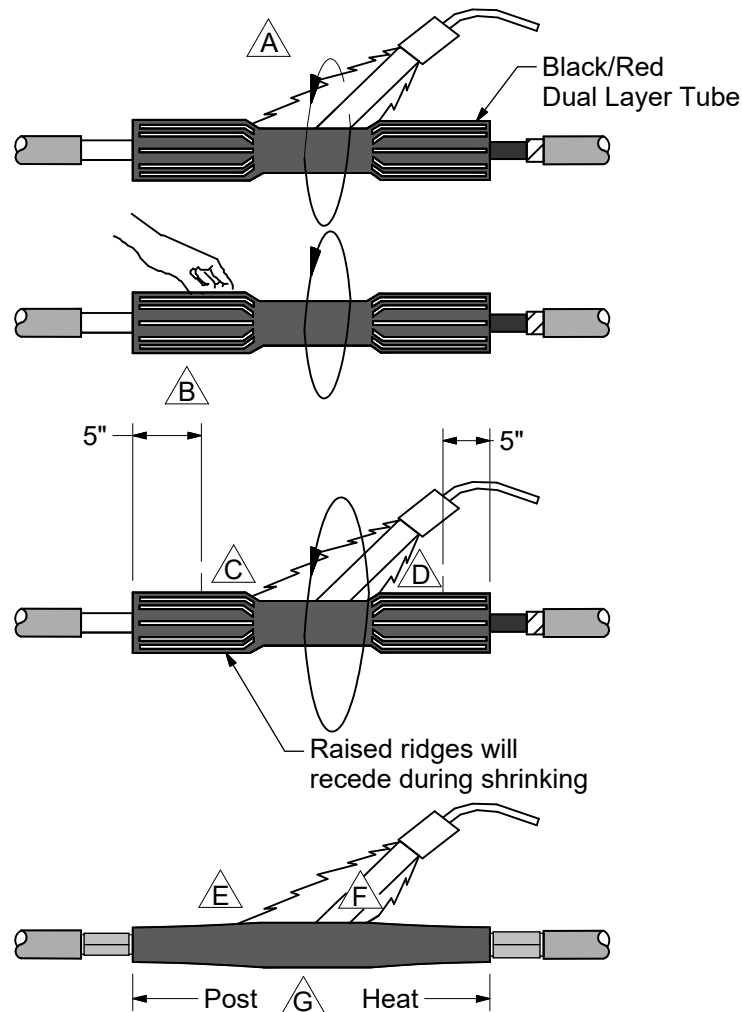
**E.** Go back to the first end and shrink the remaining 4" of tube.

**F.** Go back to the second end and shrink the remaining 4" of tube.

**G.** After completion of these steps, heat the entire tube for 1 minute.

**H.** Inspect the tube. Look for absence of raised ridges. A gloved hand may also be used to feel the surface of the tube for raised ridges. Absence of these ridges indicates a complete shrink down.

## 12. POSITION THE BLACK/RED DUAL LAYER TUBE AND SHRINK IN PLACE



Note: The dual layer insulating/shielding tube takes longer to shrink than previous tubes.

**A.** Center tube over joint. Begin shrinking in the center of the tube, working the torch around all sides of the tube. Pay particular attention to the back and underside of the tube.

**B.** Before continuing, gently twist the unshrunk end of the tube to feel for resistance to movement in the center indicating that the center is shrunk.

**C.** Shrink from the center toward one end and stop about 3" from the end of the tube.

**D.** Return to the center and shrink toward the other end, once again stopping about 3" from the tube end.

**E.** Go back to the first end and shrink the remaining 3" of the tube.

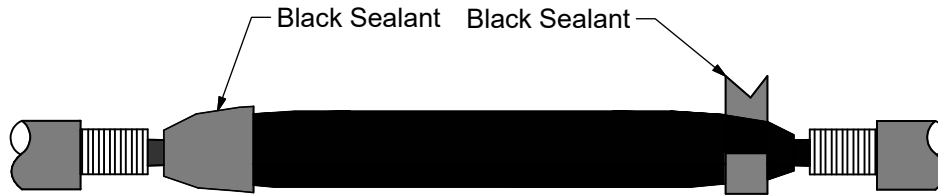
**F.** Go back to the second end and shrink the remaining 3" of the tube.

**G.** After completing these steps, heat the entire tube for about 1 minute.

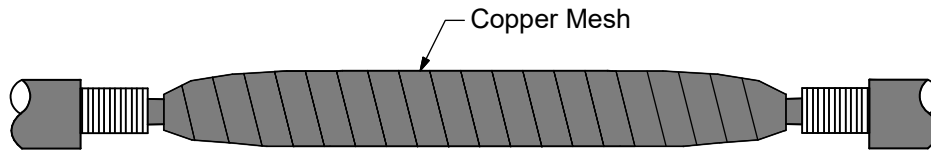
H. Inspect the tube. Look for the absence of raised ridges. A gloved hand may also be used to feel the surface of the tube for raised ridges. Absence of these ridges indicates a complete shrink down.

I. Remove the aluminum deflectors from the cables.

## 13. INSTALL SEALANT AND MESH



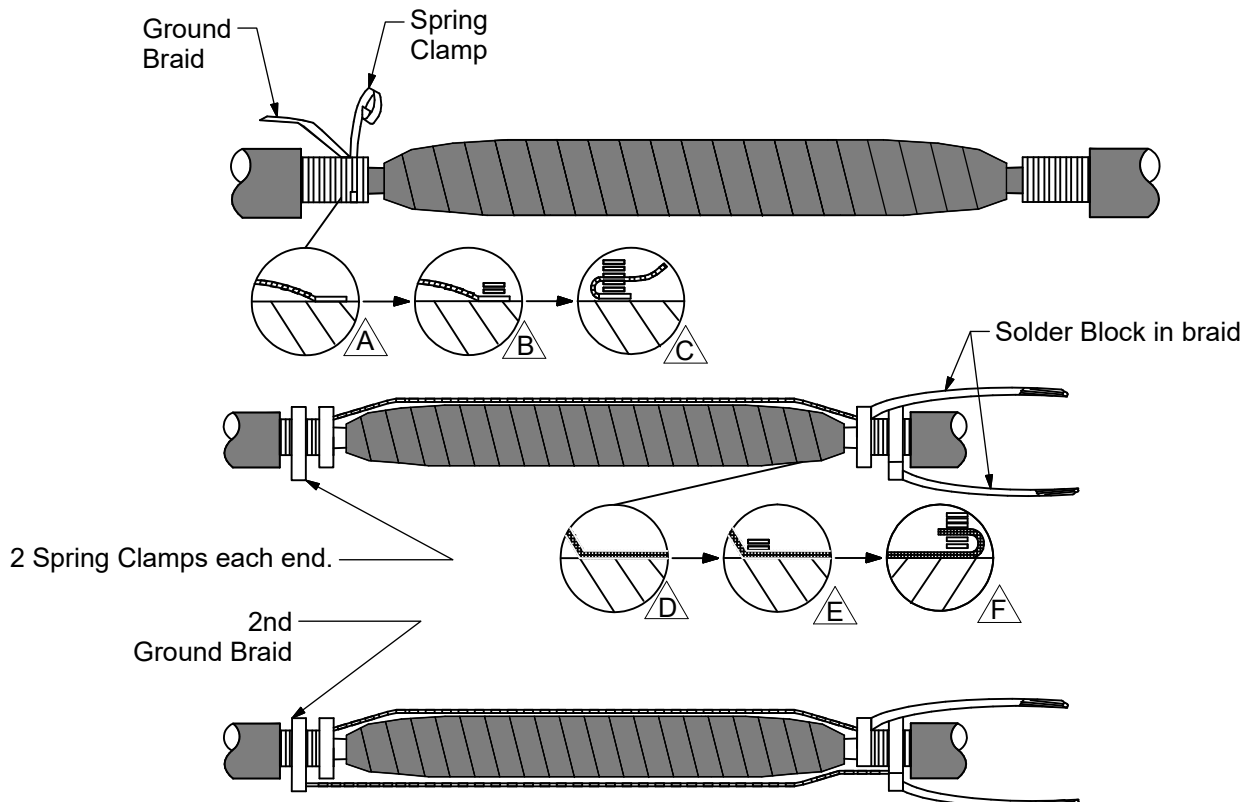
- A. Remove the backing strips from the black sealant.
- B. Apply the sealant to smooth out the steps at the sleeve ends as shown above.
- C. Apply the sealant onto the semicon being careful not to overlap onto the metallic shields.



- D. Wrap a half lapped layer of copper mesh across the splice butted up to the metallic shield on both sides and tie off.

## 14. INSTALL AND CONNECT GROUNDING

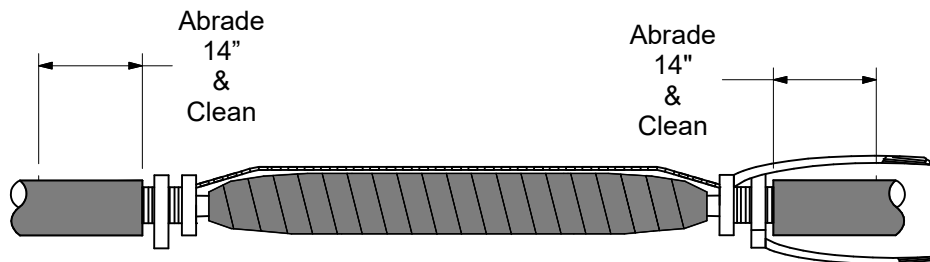
(External Grounding with 2#2 AWG Solder Blocked Braids, Without Shield Break)



- A** Position the solder blocked portion of the braid at the end of the jacket on either side of the splice with the short covered portion positioned away from the splice. Repeat with the second braid. Use tape to hold the braids in place.

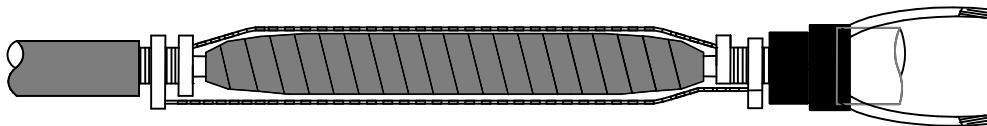
- △ B. Use the heavy duty constant tension clamps to attach the 2 braids to the metallic shield. Make two wraps of spring clamp over the braid.
- △ C. Fold the braids back over the spring clamps. Continue to wrap the remaining clamp over the braid. Tighten the clamp by twisting it in the direction it is wrapped and secure with copper foil tape.
- △ D. Lay the braids across the splice tube and onto the metal shield on the other side of the splice.
- △ E. For each braid, make two wraps of each clamp over the braid.
- △ F. Fold the braids back toward the splice and finish wrapping the clamp. Tighten and secure each braid. Cut off excess braid. The second ground braid should be placed opposite the first ground braid and the second set of spring clamps installed outside of the first set of spring clamps and over the metallic shield.

## 15. CLEAN AND ABRABE CABLE JACKETS



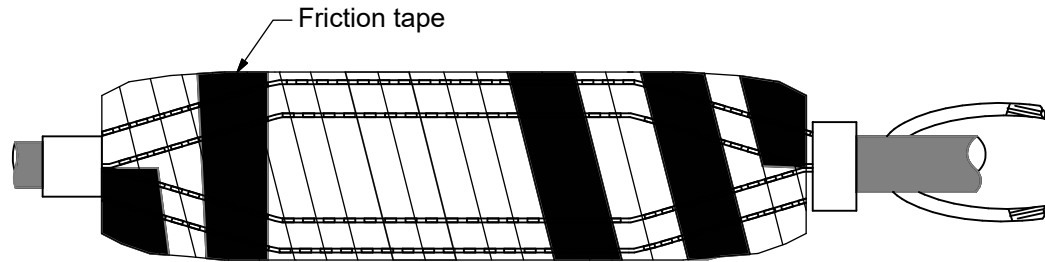
- A. Abrade the cable jackets and clean with an approved solvent.

## 16. APPLY THE BLACK SEALANT



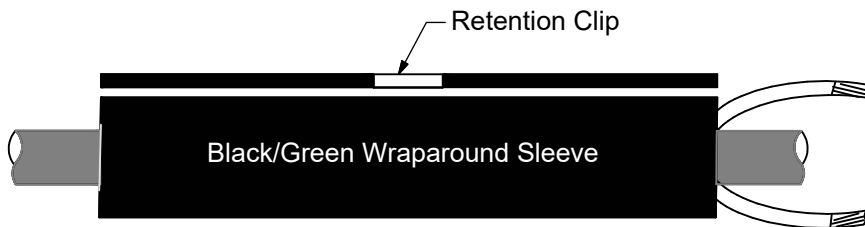
- A. Apply one wrap of black sealant starting at the jacket cutbacks around both cable jackets.
- B. On the external braid end apply a second one wrap layer of sealant next to the first one on the cable jacket. Push the solder blocks and covered braid ends into the sealant.
- C. Wrap one more layer of black sealant over the top of the first two layers to encapsulate the solder blocks and the covered external braid ends.

## 17. APPLY FRICTION TAPE



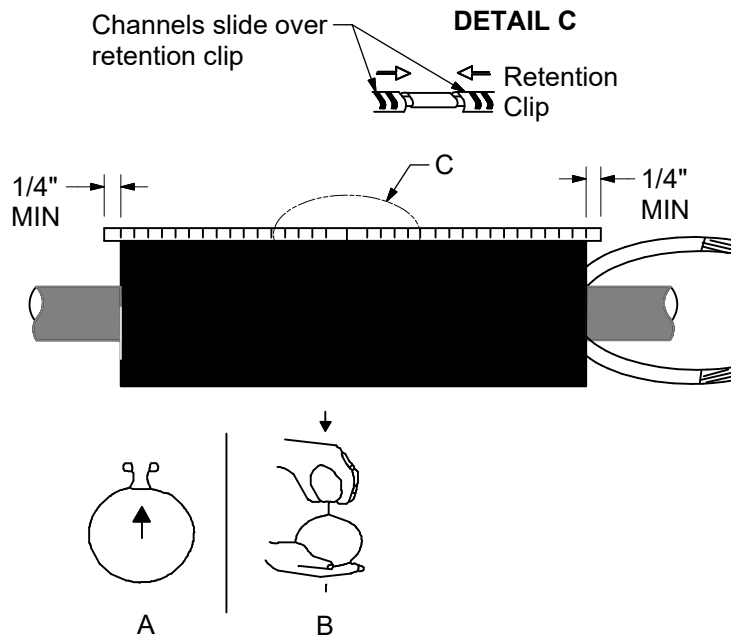
- A. Apply a wrap of friction tape to hold the ground braids in position.
- B. Tape down external braid ends.
- C. Tape over all sharp points.

## 18. POSITION OUTER WRAP AROUND SLEEVE



- A. Remove the backing from the wrap around sealing sleeve and center the sleeve over the splice.
- B. Slide the metal retention clip onto the butted rails and position in the center of the sleeve.

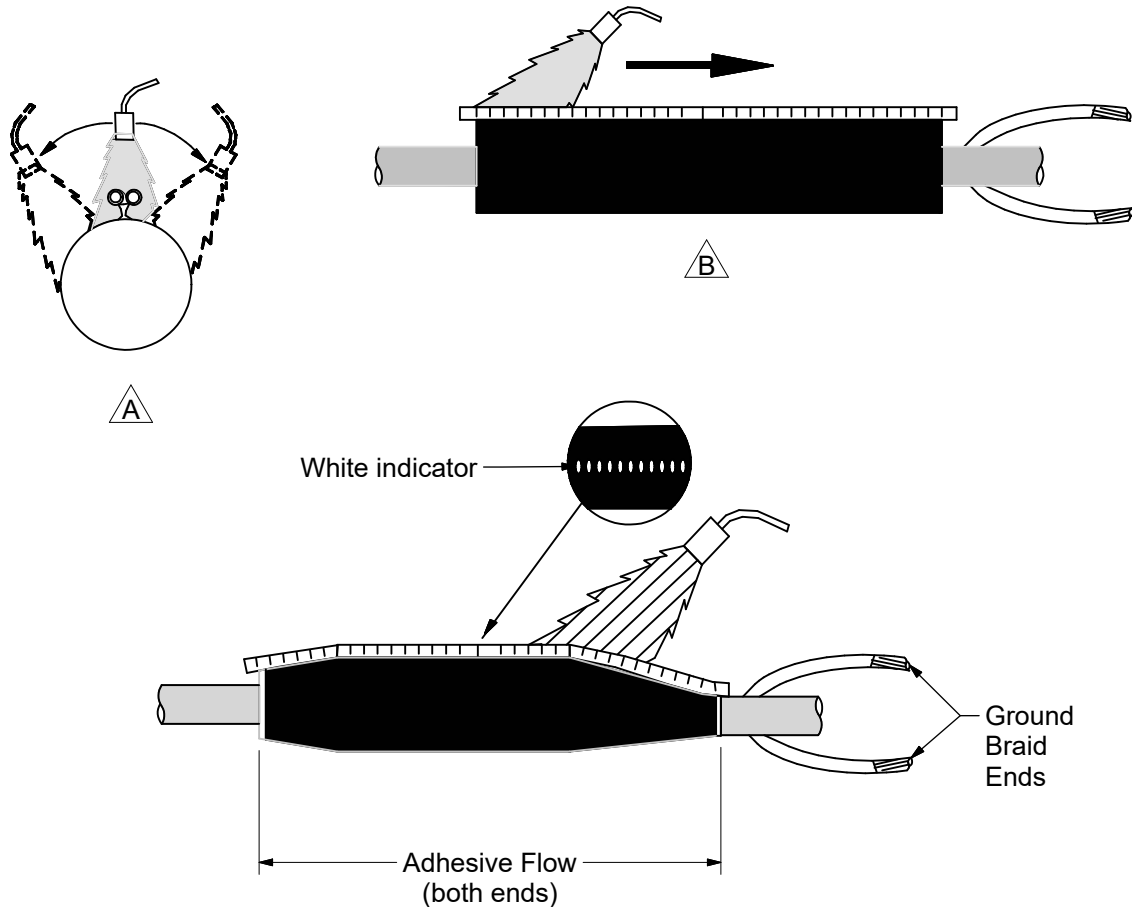
## 19. INSTALL THE CHANNELS



- A. Slide the channels onto the rail.
- B. Connect the channels by having them overlap the retention clip as shown. (Channels must overlap the edge of the wrap around sleeve by 1/4" minimum.)

- C. If the channels fit tight make sure that the sleeve flap is not pinched between the rails (A).
- D. Push the sleeve up from the bottom and down from the top while sliding the channels onto the sleeve (B). This keeps the channels from binding

## 20. SHRINK THE WRAP AROUND SLEEVE



- A. Preheat evenly along both sides of the rail/channel area until this area begins to shrink.
- B. In order to achieve a uniform heating, move the flame back and forth from one side of the channel to the other (A) while also moving the flame along the entire length of the channel (B) until the sleeve starts to shrink.
- C. Begin shrinking at the center of the sleeve and work toward each end.
- D. Apply heat until the sleeve is fully shrunk and the heat sensitive green paint is completely converted to black.
- E. Continue heating the rail/channel area for another 5 seconds per foot. A white line should be visible in the channel gaps indicating sufficient heating.
- F. This completes the splice.
- G. Connect external ground braid ends into ground rods or ground bond wire using ground clamps or two bolt clamps and covering the connections with plastic tape.
- H. Allow the splice to cool before moving it or placing it in service.





# UNDERGROUND CABLE SPLICE

Heat Shrinkable  
500 kcmil – 1000 kcmil

<b>41 54 30 **</b>
<b>69 KV</b>
<b>11 of 11</b>

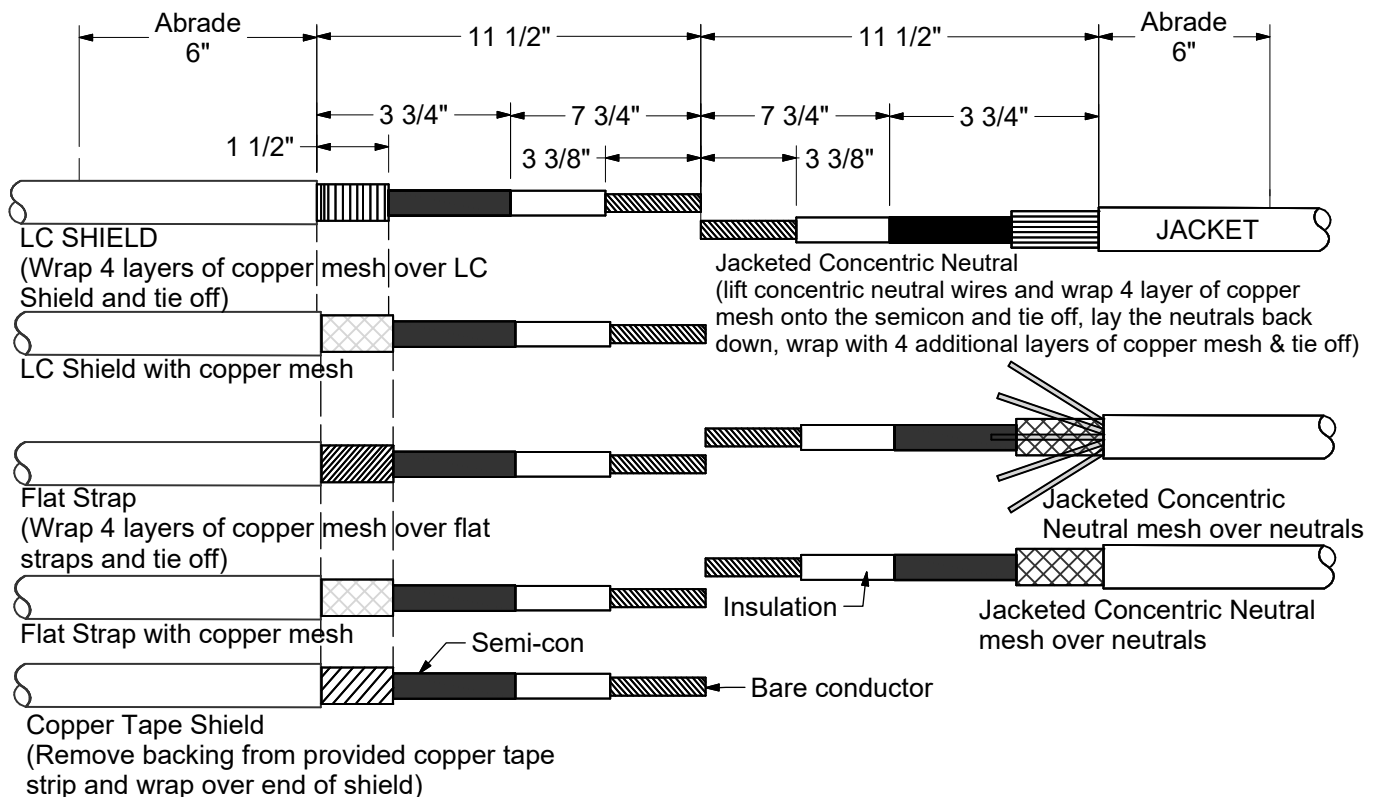
DCS #	DESCRIPTION
41 54 30 01	750 kcmil, AL, 69kV Cable
41 54 30 02	500 kcmil, AL, 69kV Cable
41 54 30 03	1000 kcmil, CU, 69kV Cable

	ITEM	STK / DCS #	DESCRIPTION	01	02	03
	A	17 05 313	Splice - 500-750 kcmil, 69kV	1	1	-
		17 05 538	Splice - 1000 kcmil, 69kV	-	-	1
	B	17 54 378	Connector, Shearing Screw, 750 kcmil AL/CU	1	-	-
		17 54 379	Connector, Shearing Screw, 500 kcmil AL/CU	-	1	-
		17 54 971	Connector, Shearing Screw, 1000 kcmil AL/CU	-	-	1
	C	25 53 055	Tape - Plastic (RL)	1	1	1
	D	25 53 027	Tape - Friction, 1 1/2" Wide (RL)	2	2	2
@	E	17 54 140	Connector - Two Bolt	2	2	2
@	F	17 52 032	Clamp - Ground Rod, Cast Bronze	2	2	2
@	G	18 54 027	Wire - 2 Cu.	#	#	#

REV	DATE	ENG	DESCRIPTION
2	01/01/23	EJB	Converted to new format
1	10/01/10	EJB	

**INSTRUCTIONS:**

1. Prepare the Cables and Apply the Copper Mesh as Shown in Figure 1.
  - A. The copper mesh installation requirements, for each jacketed cable type, are shown in Figure 1. If bare concentric neutral cable must be spliced, go to Step "1" for cable preparation instructions.
  - B. Wrap the copper mesh around the cable so that it is located in the 1-1/2" metallic shield area as shown. The copper mesh should be pulled tight around the cable and tied off. After tying off the copper mesh, cut it so that only a very short tail remains.
  - C. Use Stock #22 05 213 or the aluminum oxide strip included in the splice kit to abrade/scuff tcable jacket, see Figure 1.



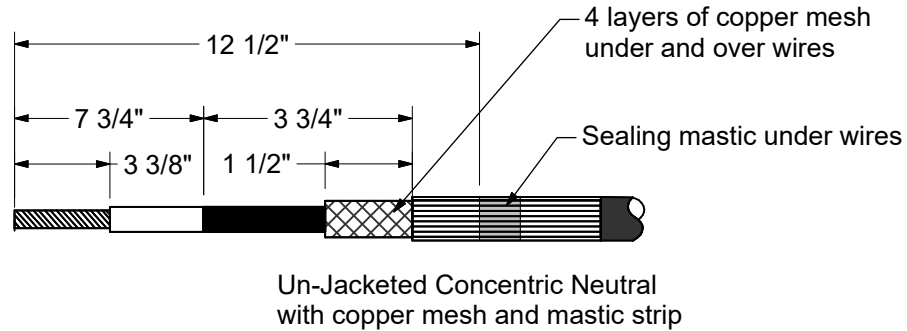
**Figure 1**

Initial when Step 1 is complete. \_\_\_\_\_

REV	DATE	ENG	DESCRIPTION
1	01/01/23	EJB	Converted to new format
	xx/xx/xx	EJB	

1A Prepare Bare Concentric Neutral Cables

A. Bare concentric neutral cable will be prepared using the dimensions shown in Figure 2.



**Figure 2**

- A. After preparing the BCN cable as shown in Figure 2, carefully lift the bare concentric neutral wires and clean the underlying semicon.
- B. Wrap a strip of the gray sealing mastic under the concentric neutral wires. Place the mastic strip 12 1/2" from the end of the cable.
- D. While the concentric neutral wires are still lifted, wrap four layers of copper mesh around the cable and tie off the end. The copper mesh wrap must start 10" from the end of the cable and end 11 1/2" from the end of the cable.
- E. Lay the concentric neutral wires back down over the semicon, making sure the ends of the concentric neutral wires align with the edge of the copper mesh. Press the concentric neutral wires into the sealing mastic.
- F. Apply four additional wraps of copper mesh over the concentric neutral wires and tie off. Verify that the installed copper mesh provides a 1 1/2" connection area at the ends of the concentric neutral wires.

Initial when Step 1A is complete. \_\_\_\_\_

REV	DATE	ENG	DESCRIPTION
1	01/01/23	EJB	Converted to new format
	xx/xx/xx	EJB	

## 2. Place Splice Body Over Cleaned Cable

- Clean 30" of cable jacket on the cable where the splice body will be placed or stored prior to making the shearbolt connection.
- Slide the splice body over the cable end so that the holdout core release strip points toward the cable end.
- Figure 3 shows the placement of the splice body on the cable. Also shown in Figure 3 is the optional use of the plastic bag supplied with the splice body to cover the cable to maintain cleanliness.

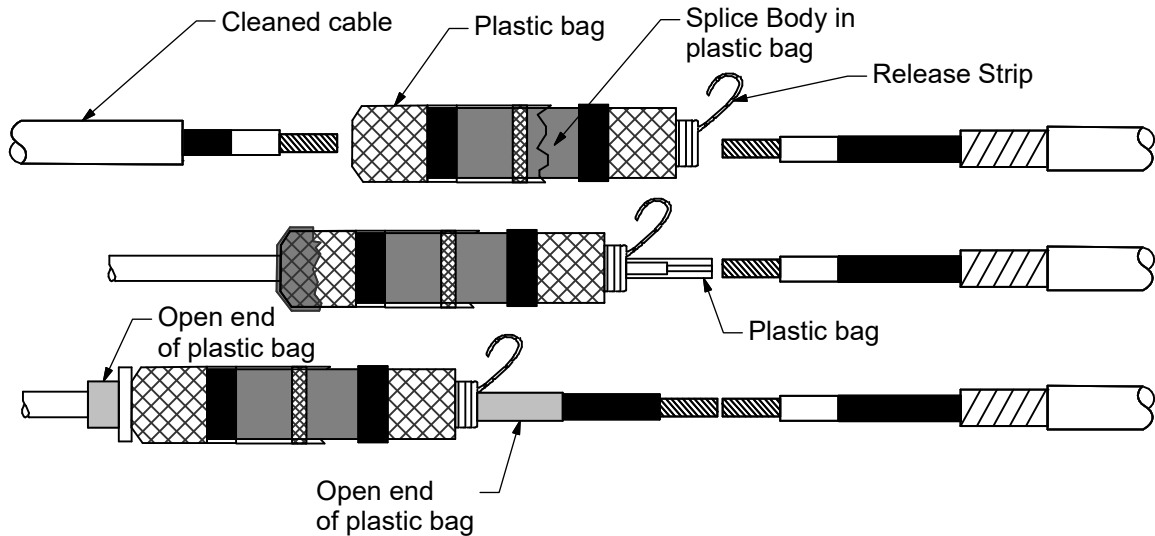


Figure 3

Initial when Step 2 is complete. \_\_\_\_\_

## 3. Install Shearbolt Connector

- Before shearing bolts, confirm that the dimension between semi-con cutbacks is between 15 1/2" and 16 1/4" for proper placement of the splice body. See Figure 4.
- Use the small wire brush included in the kit to clean the surface of the aluminum conductor before placing the conductor into the connector.
- If the conductor is larger than 400 kcmil, don't use the inserts in the connector.
- Insert the cable conductor into the connector until it butts up with the centerstop of the connector.
- Tighten the shear bolts by hand until they are snug against the conductor. Complete the installation by tightening and shearing the bolts in the sequence shown in Figure 4. Use an 8mm hex socket (85-32-776). Install the plastic caps over the shear bolt holes.

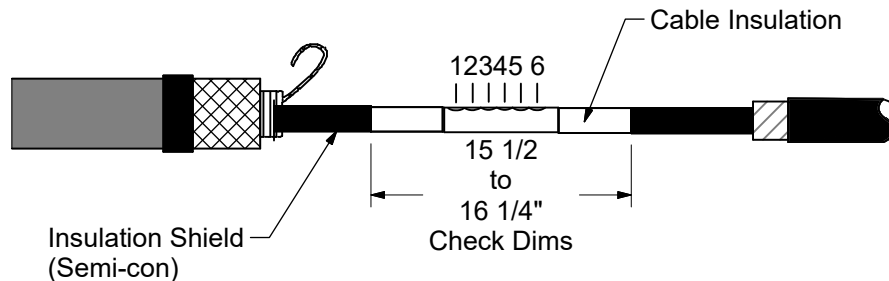
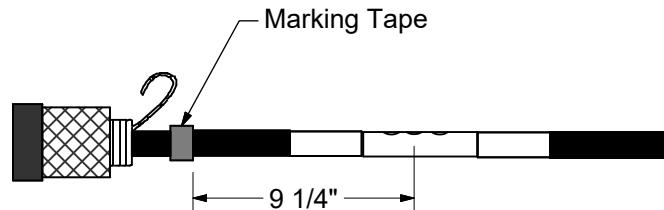


Figure 4

Initial when Step 3 is complete. \_\_\_\_\_

4. Clean Cable and Install Marking Tape
  - A. CLEAN AND DEGREASE THE CONNECTOR AREA (REMOVE ALL EXCESS INHIBITOR).
  - A. CLEAN THE CABLE INSULATION. WHEN CLEANING THE INSULATION, ALWAYS WIPE TOWARD THE SEMI-CON.
  - C. Install several turns of marking tape onto the cable semi-con 9 1/4" from the center of the connector as shown in Figure 5. This tape will be used as a guide for positioning the splice body. The marking tape is to be installed on the same cable that the splice body is on.

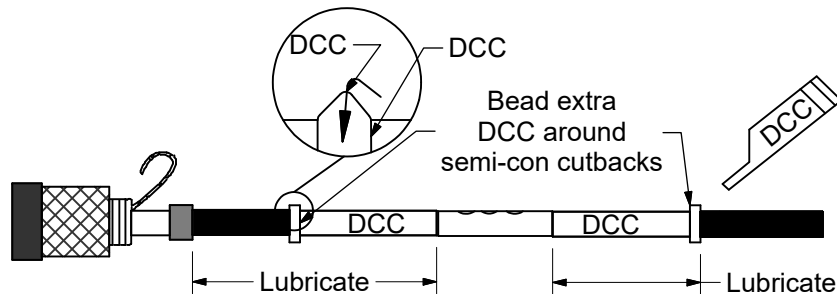


**Figure 5**

Initial when Step 4 is complete. \_\_\_\_\_

## 5. Lubrication

- A. Put on the glove provided in the kit and then use the gloved hand to lubricate the cable insulation up to the semi-con cutback and marking tape with the supplied DISCHARGE CONTROL COMPOUND (DCC). Be sure to use extra DCC to form a bead around the semi-con cutbacks on each cable. See Figure 6 for areas to lubricate.
- B. USE ALL OF THE DCC SUPPLIED IN THE KIT TO HELP FILL VOIDS. DO NOT USE STANDARD SILICONE GREASE.



**Figure 6**

Initial when Step 5 is complete. \_\_\_\_\_

## 6. Installation of Splice Body

- A. If the optional plastic bag was used in Step 2 to maintain cleanliness, it should now be removed.
- B. Position the splice body so that the silicone splice body's transparent edge is aligned with the edge of the marking tape. It is important that the splice body remain aligned with the marking tape while the spiral holdout is removed.
- C. Remove the spiral holdout (core) by pulling the release strip counterclockwise while holding the splice body in place. The spiral holdout cannot be pulled out all at once. Slowly pull the spiral holdout on top of the cable and then pass it around and underneath the cable until the spiral holdout has been completely removed. Once the splice is partially shrunk adjacent to the marking tape, there is no need to hold the splice. Use two hands at this point to remove the remaining spiral holdout. (See Figure 7.)
- D. Remove the marking tape.

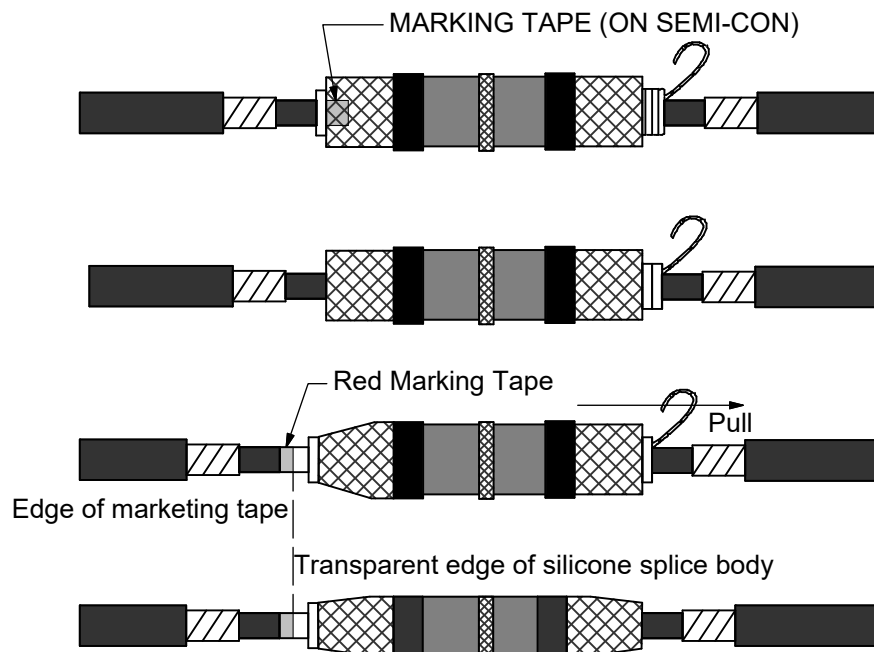
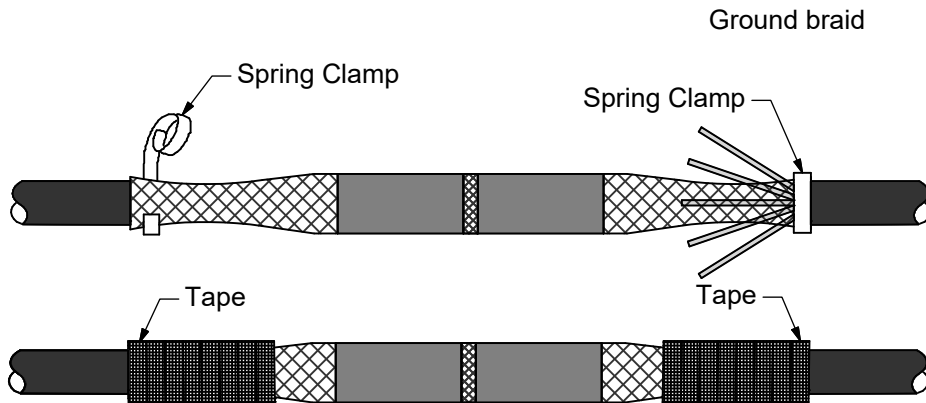


Figure 7

Initial when Step 6 is complete. \_\_\_\_\_

7. Straighten Out Mesh Sock Wires, Install Spring Clamps & Tape

- A. IF AN EXTERNAL GROUND CONNECTION IS REQUIRED, PROCEED TO STEP 8.
- B. USE THE SMALL SPRING CLAMP "F" FOR 15 KV CABLES UP TO AND INCLUDING 500 KCMIL AND 1/0 35 KV. FOR ALL OTHERS, USE THE LARGE SPRING CLAMP "G".
- C. Remove the black tape holding the ends of the mesh sock wires on the splice body. If a knife is used to cut the tape, take care not to damage the underlying re-jacketing material.
- D. Straighten the mesh sock wires out over the previously installed copper mesh tape. Install two turns of the spring clamp over the mesh sock and the mesh tape covering the cable metallic shield. After two turns are installed, fold the mesh sock back over the spring clamp and continue to install the remaining turns on the spring clamp over the mesh sock.
- E. Secure the spring clamp with three wraps of vinyl tape (Stk. # 2553055) wrapped in the same direction as the spring clamp. Continue taping over the ends of the mesh to cover all sharp points. Follow the above steps to complete the other side. See Figure 8.



**Figure 8**

Initial when Step 7 is complete. \_\_\_\_\_

REV	DATE	ENG	DESCRIPTION
1	01/01/23	EJB	Converted to new format
	xx/xx/xx	EJB	

## 8. Installation of Wraparound Ground Braid Used for External Ground Connection Optional

- A. Straighten the mesh sock wires out over the previously installed copper mesh. Fold the edges of the mesh sock back toward the center of the splice end where the ground braid will be installed. If the edges of the mesh sock are very long, they may be secured with vinyl tape.
- B. Select one of the three mastic strips from the grounding kit (Stk. # 1754306). Remove liners and wrap the mastic around the cable jacket, 1/2" from the cut edge. Discard any excess mastic from the piece.
- C. Position the twin preformed ground braid over the folded back mesh sock with one tail along the cable jacket. Verify that the ground braid is positioned over the 1 1/2" area where the cable metallic shield and copper mesh tape are located. Press one tail of the preformed ground braid into the previously applied mastic and secure the tail to the cable jacket with vinyl tape, 1 1/2" from the edge of the jacket. Additional wraps of vinyl tape can be used along the length of the tail to hold it into place.
- D. Wrap the braid around the mesh sock and metallic shield of the cable. Secure the ground braid with a spring clamp from the splice kit. Use the small spring clamp "F" for 15 kV cable up to and including 500 kcmil and 1/0 35 kV. For all others, use the large spring clamp "G". Wrap the spring in the same direction as the braid and tighten the final lap.
- E. Position the second tail of the preformed ground braid along the cable and secure the tail to the cable with vinyl tape. Press the second tail into the previously applied mastic strip.
- F. Apply a second mastic strip layer over the braid tails. The second mastic strip must be positioned so that it overlays the previously installed mastic strip. Press the two mastic strips together to form a water tight seal around the ground braid tails.
- G. Secure the spring clamp with three wraps of vinyl tape (Stk. # 25 53 055) wrapped in the same direction as the spring clamp. Continue taping over the ends of the mesh to cover all sharp points.
- H. Connect the other end of the mesh sock as detailed in Step 7. See Figure 9.

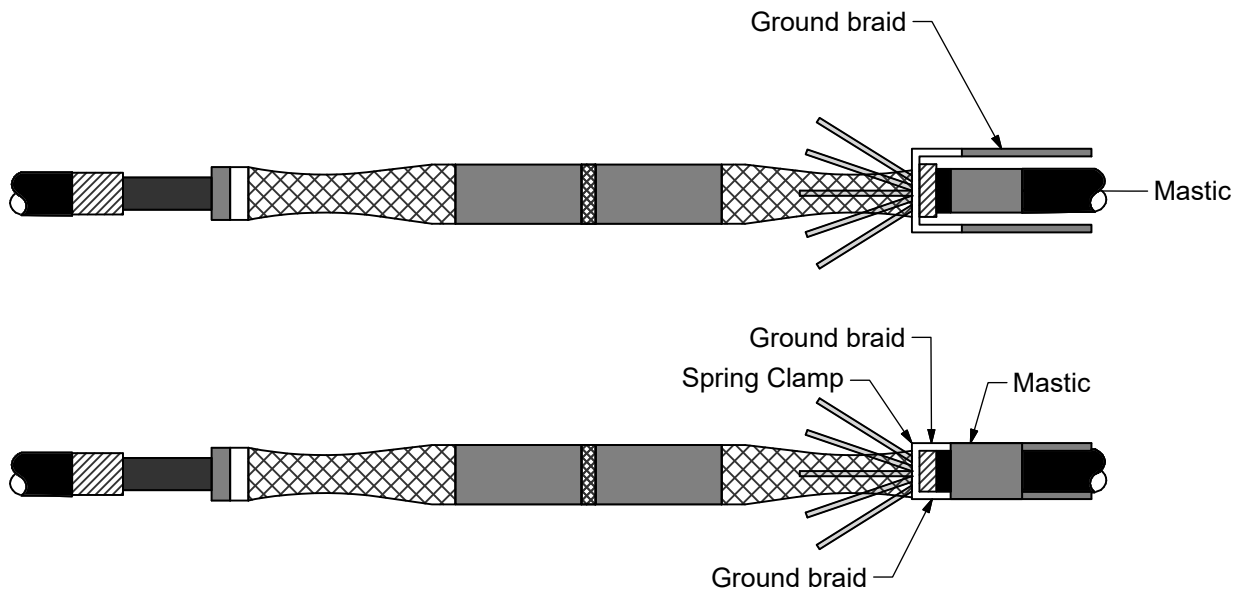


Figure 9

Initial when Step 8 is complete. \_\_\_\_\_



## 9. Expand Re-Jacketing Sleeve

- A. Install a strip of gray sealing mastic at each jacket cutback. Be sure that mastic has been applied under and over the tails of the external ground braid if one is installed. If Bare Concentric Neutral cable is being spliced, be sure to apply a strip of gray sealing mastic over the strip that was applied under the concentric neutral wires in Step 1.1.
- B. Wipe off the black re-jacketing sleeve to allow for a positive grip on the sleeve. Twist the black re-jacketing sleeve from side to side to release the lubricating grease. Slide one side of the re-jacketing sleeve over the mesh sock and spring clamp connector and onto the cable jacket. Repeat this step on the other side.
- C. Cut off the red mesh sleeve, being careful not to damage the re-jacketing sleeve or the splice body.
- D. Using approved solvent, clean the surface to the re-jacketing sleeve to remove excess grease.
- E. Wrap four layers of vinyl tape (Stk. # 25 53 055) over each end of the re-jacketing sleeve. The tape is not being applied to seal the re-jacketing sleeve. The vinyl tape is being applied to finish the ends of the re-jacketing sleeve. See Figure 10.

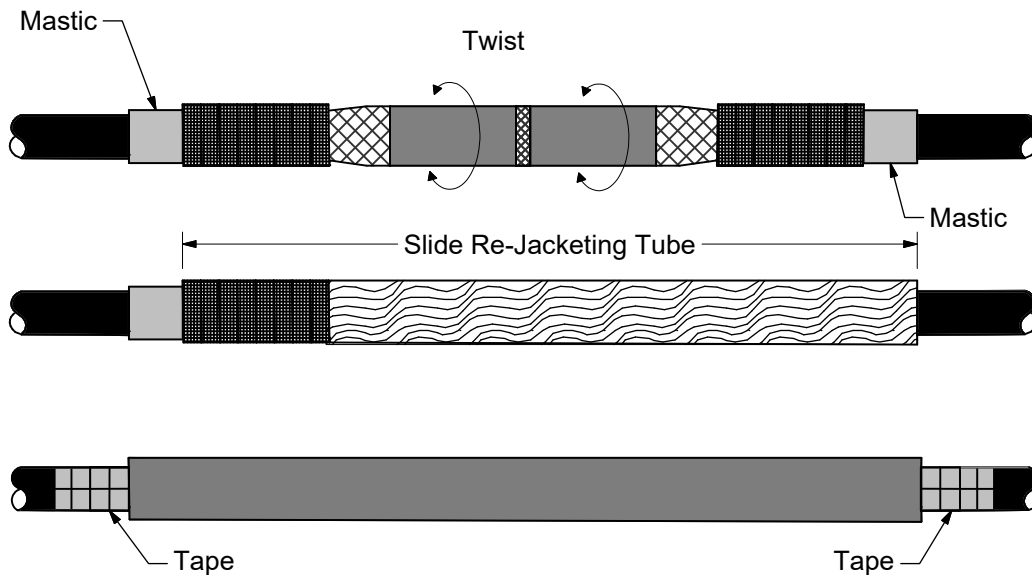
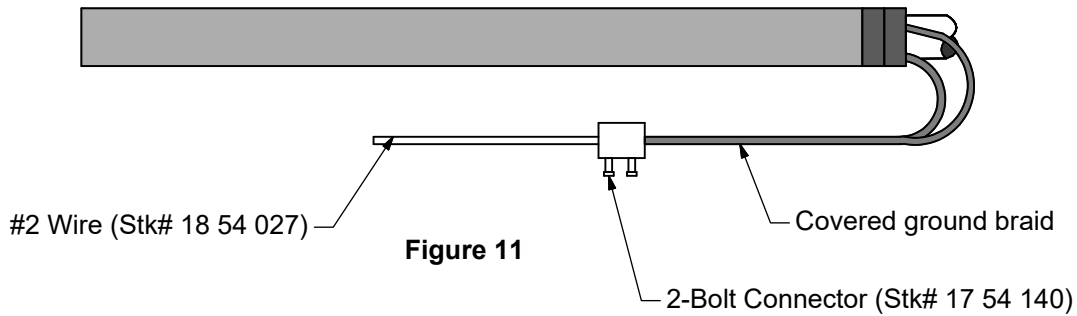


Figure 10

Initial when Step 9 is complete. \_\_\_\_\_

10. Connect Ground Braid to System Ground (Only if External Ground Braid was Installed in Step 8)

- A. Connect the external ground braid ends to the system ground with a 2-bolt connector (Stock #17 54 140) and a #2 copper wire (Stock #18 54 027).
- B. Seal the 2-bolt connection with poly sealer (Stock #31 53 055). Tape over poly sealer with vinyl tape (Stock #25 53 055). See Figure 11.



Initial when Step 10 is complete. \_\_\_\_\_

	ITEM	STK / DCS #	DESCRIPTION	00
	A	17 05 500	Splice - 350-750 kcmil Cu/AL, 15/35 kV	1
	B	25 53 055	Tape - Vinyl	1
@	C	17 54 306	Connector - Cable Ground w/Constant Force Spring	1
@	D	17 54 140	Connector - Wire, #8-4/0 Cu, 2-Bolt	1
@	E	31 53 055	Compound - Sealer	1