TABLE OF CONTENTS

December 15, 2021

[FORW - Forward](#) [Field Reference Guide](#) Manual User Guide [O&M Change Summary](#)

[ABND - Abandonment of Facilities](#)

[ACIG - Accidental Ignition](#)

[APPR - Apprentice Training](#)

[BORE - Boring](#)

[CLAS - Class Location and Consequence Areas](#)

[CNTS - Continuing Surveillance](#)

[CONF - Confined Space](#)

[CONS - Gas Construction Oversight](#)

[CORR - Corrosion Control](#)

[DAMG - Damage Prevention](#)

[EMER - Emergency Plan](#)

[EXCV - Excavation Safety](#)

[FORW - Forward](#)

[GLOS - Glossary](#)

[INCD - Incident Reporting](#)

[INVE - Investigation of Incidents](#)

[LEAK - Leak Management](#)

[LOCT - Locating](#)

[MAIN - Main Installation](#)

[METR - Metering](#)

[ODOR - Odorization](#)

[OQAL - Operator Qualification](#)

[PCBH - PCB Handling](#)

[PIGG - Pigging](#)

[PMRK - Pipeline Markers](#)

[POLY - Polyethylene Pipe](#)

[PRES - Pressure Monitoring](#)

[PTSL - Pipeline Patrols](#)

[PTST - Pressure Testing](#)

UNCONTROLLED IF PRINTED

[PUBL - Public Education](#)

[PURG - Purging](#)

[QUAL - Quality Assurance Program](#)

[REGS - Regulator Stations](#)

[REPR - Repairs](#)

[RNST - Reinstating of Facilities](#)

[SAFT - Safety Related Conditions](#)

[SECR - Security Plan](#)

[SERV - Service Line Installation](#)

[STLP - Steel Pipe](#)

[TAPS - Tapping and Stopping](#)

[TURN - Turn-On Turn-Off](#)

[UPRT - Uprating](#)

[VALT - Vault and Pit Inspection](#)

[VALV - Valves](#)

[WELD - Welding](#)

[WIGE - Working in Gaseous Environment](#)

[SUMM - Change Summaries](#)

[Gas Storage - Table of Contents](#)

FORWARD

October 1, 2022

1.0 Purpose

The Ameren Illinois' Gas Operating and Maintenance (O&M) Plan describes procedures and requirements for the operation and maintenance of Ameren Illinois' (AIC) natural gas transmission and distribution facilities. The O&M manual also describes routine and emergency reporting and notification requirements. This manual meets the requirements of 49 CFR §192.605 and Illinois Administrative Code Section 590.30.

2.0 Annual Review

Gas Standards and Procedures will ensure the O&M plan is reviewed each calendar year not to exceed 15 months for the effectiveness of existing procedures.

3.0 New and Revised Procedures

New and revised procedures shall be approved by Gas Standards and Procedures personnel and will be included in the next periodic update of the O&M manual. New and revised procedures may be a result of:

Safety concerns.

New technology.

New equipment, instruments or tools.

Material that is being evaluated or has been approved for use.

Regulatory requests.

Company review and evaluation.

Gas Training and Operator Qualification (OQ) staffs will review and determine if the procedure involves a covered task requiring operating personnel to be OQ'd and if training is needed prior to implementation.

Any revisions to the O&M plan shall be communicated to all affected AIC personnel.

4.0 O&M Plan Filing and Management

Gas Standards & Procedures is responsible for the updating and distribution of new and revised procedures. The O&M plan is available electronically to all employees and contractors involved with the operation and maintenance of AIC's gas facilities.

Pipeline Safety and Compliance shall file an electronic copy of the latest version of AIC O&M plan with the Illinois Commerce Commission (ICC) via an AIC hosted, password protected technology platform as required in the Illinois Administrative Code Section 590.30.

5.0 Gas Operations and Services Contacts

Gas Operations and Services	Name	Office Number	Cell Number
Pipeline Safety & Compliance	John Bozarth	217-625-6854	217-257-6276
	Charles Rayot	217-625-6802	217-836-5133

UNCONTROLLED IF PRINTED

Maximo, ClickMobile, ClickSchedule	Tyler Beeler	217-625-6896	217-710-0853
	Patty Marcolini	217-625-6858	N/A
Gas Training	Janel White	217-625-6859	217-622-6239
Gas Quality Assurance	Mark Popov	618-301-5343	618-806-3726
Gas Standards & Procedures	Ben Dori	618-301-5241	618-719-6856
	Jim Burke (O&M)	618-253-1694	618-964-4494
	Victoria Mauch (O&M)		912-604-4645
	Austin Jones (Tools & Material)		618-593-7155
	Cade Larson (Tools & Material)		815-641-3479
	Rachel Cruse (Failed Material)		314-343-9458
Gas Tech Engineering (GTE)	Carey Phelps	217-424-6952	217-891-5434
	Mike Wetherell (Transmission Engrg)	217-424-6677	217-358-3096
	John Kaczmarek (HP Dist, Measurement/ Control)	217-424-6492	217-329-4250
	Jeff Mays (Planning)	217-424-6947	217-620-3152
Gas Integrity Management	Tim Delaney	217-424-6886	217-358-9172
	Ryan Jozwiak (DIMP)	217-424-6505	
	Will Peabody (TIMP)	217-424-8205	217-521-7271
	Fred Halabi (Corrosion Control)	309-677-7957	309-264-5914
Gas Technical Services (GTS)	Gene Eagle	217-424-6542	217-412-6432
Gas Control & Dispatch	Autumn Kamnick	217-753-5121	217-6228982
Gas Storage	Steve Underwood	217-424-6960	309-253-8500

UNCONTROLLED IF PRINTED

Construction Services	Mark Mancewicz	618-3438186	217-494-2962
Gas Control	Controller On-Duty	800-367-2477	
Distribution Control	Dispatcher On-Duty	800-484-2604	

Document Rescission

FORW – Forward, December 15, 2021.

Revision Notes

Location of Changes	Summary of Changes
Gas Operations and Services Contacts	Updated names and phone numbers

ABND-Abandonment of Facilities

ABANDONMENT OF FACILITIES

December 1, 2020

ABND 0 Table of Contents

[ABND 1 Abandonment of Facilities: Requirements](#)

- Section 1.0 Purpose
- Section 2.0 Scope
- Section 3.0 Target Audience
- Section 4.0 Pre-Abandonment Planning
- Section 5.0 Project Specific Procedures
- Section 6.0 Records
- Operator Qualification
- Compliance Requirements
- Reference Documents
- Document Rescission

[ABND 2.1 Abandonment of Facilities: Abandonment of Gas Facilities](#)

- Section 1.0 Purpose
- Section 2.0 Scope
- Section 3.0 Target Audience
- Section 4.0 Abandonment - General
- Section 5.0 Transmission Lines and Distribution Mains
- Section 6.0 Services
- Section 7.0 Inside Meters
- Section 8.0 Verification of Main or Service Status
- Section 9.0 Commercially Navigable Waters
- Section 10.0 Vaults
- Section 11.0 Records
- Operator Qualification
- Attachments
 - Attachment 1 - Continental Abandonment Kit Instructions
 - Attachment 2 - Mueller Steel Abandonment Cap for H-17800 Curb Stop Tees
 - Attachment 3 - Polywater AFT Sealant

UNCONTROLLED IF PRINTED

Compliance Requirements

Reference Documents

Document Rescission

End Table of Contents.

Document Rescission

ABND 0 Abandonment of Facilities: Table of Contents, April 1, 2020.

Revision Notes

Location of Changes	Summary of Changes
Not applicable.	This is a new document.

ABANDONMENT OF FACILITIES

October 1, 2021

ABND 1 Requirements**1.0 Purpose**

This document describes the requirements for abandoning natural gas transmission and distribution facilities in accordance with 49 CFR §192.727.

2.0 Scope

This document addresses the following:

[3.0 - Target Audience](#)[4.0 - Pre-Abandonment Planning](#)[5.0 - Project-Specific Procedures](#)[6.0 - Records](#)**3.0 Target Audience**

- Distribution Design.
- Gas Field Personnel.
- Gas Engineering.
- Gas Supervisor.
- Gas Tech Engineering (GTE).
- Gas Tech Services (GTS) Supervisors.
- Gas Tech Services (GTS) Personnel.
- Gas Storage Engineers.
- Gas Storage Field Supervisors.
- Gas Storage Field Operators.
- Gas Construction Services Supervisors.
- Gas Control.

4.0 Pre-Abandonment Planning

4.1 Additional general topics for consideration include:

4.1.1 Determine if the proposed abandonment could have an impact on the associated gas system(s), thus requiring follow-up review.

4.1.2 If abandonment results in a potential impact on the associated gas system(s), consult with the affected work groups:

- Corrosion Control.
- Gas Tech Services.
- Gas Control.
- Gas Supervisor.
- Gas Engineer.
- Safety Supervisor.
- Gas Tech Engineering.
- Environmental Services

4.1.3 Is the abandonment part of a replacement, relocation, emergency, or maintenance project?

4.1.4 Where is the location of the abandonment within the system?

4.1.5 Does abandonment involve transmission or high-pressure distribution facilities, mains, pressure control stations, valves, odorizers, ERXs, or SCADA monitoring devices or facilities?

4.1.6 Does abandonment involve any pipeline that crosses a roadway?

UNCONTROLLED IF PRINTED

- 4.1.7 Does abandonment involve any pipeline that crosses over, under, or through a commercially navigable waterway?
 - 4.1.8 Does abandonment involve an underground natural gas storage facility?
 - 4.1.9 Is the cathodic protection affected on the remaining system?
 - 4.1.10 Are there other gas sources entering into the system?
 - 4.1.11 Is the system remotely monitored by Gas Control?
 - 4.1.12 Is there a need for system modeling to identify and quantify potential impact(s) due to abandonment?
 - 4.1.13 Is there an associated environmental impact (i.e. contaminated soil, pipe coating, building demolition)?
- 4.2 If Gas Control is requested to provide monitoring, Gas Control shall be notified before and after the project.

5.0 Project Specific Procedures

- 5.1 Gas Tech Engineering (GTE) or Gas Storage Engineering (GSE) shall prepare written project procedures for abandoning facilities on projects the meet the following criteria:
- 5.1.1 Transmission facilities, or
 - 5.1.2 High pressure distribution facilities with MAOP over 100 psig, or
 - 5.1.3 Joint abandonment of transmission lines or high pressure distribution mains with MAOP over 100 psig with connected services.

If the abandonment is a result of an emergency project or maintenance project, procedures can be developed as a joint effort between regional engineering and GTE. The Regional Gas Supervising Engineer shall ensure the abandonment job packet is submitted to GTE.

- 5.2 Engineering personnel (i.e. Distribution Design Specialist or Engineer, Region Gas Engineer) shall prepare written project specific procedures for abandoning facilities on projects that meet the following criteria:
- 5.2.1 Distribution facilities with MAOP up to and including 100 psig, and
 - 5.2.2 Joint abandonment of distribution main with 10 or more connected services.
- 5.3 Specific procedure will include, at a minimum:
- 5.3.1 Operation Checklist, refer to [PRES 2.1 9.0](#) Activities Requiring an Operational Checklist and Written Procedures.
 - 5.3.2 Written procedures along with maps should address such issues as:
 - 1. Maps should show locations of such items as:
 - 1 a. Location of control fittings and tie-end connections.
 - 1 b. Tap locations for services on corner lots to insure there are no unanticipated customer outages.
 - 1 c. Location of the current feeds to the section to be abandoned

- 1 d. Main and/or service valves to be closed during the abandonment project.
- 1 e. Location of insertion and exhaust purge points.
- 1 f. Pressure monitoring locations in adjacent connecting sections that are to remain active, if possible.
2. Sequence of shutting of gas supply and tie-over operations.
3. Need for installation of gauge taps for pressure gauges.
4. Abandonment of services associated with main abandonment.
5. Check of cathodic protection on the remaining active sections.
6. Removal of above grade and grade level appurtenances.
7. Handling of unforeseen problems that may arise during the operations.

The responsible Engineer or Engineering group should be consulted with prior to making any significant changes such as: the cut-off location, abandonment method, method to purge.

5.3.3 Purge Plan in accordance with [PURG 2](#) Purging: Methods

5.3.4 A pre-job meeting should be held to review the written procedures.

5.3.5 When required communicate with other work units:

1. Region Gas Operations.
2. Gas Tech Engineering.
3. Gas Tech Services.
4. Gas Storage Engineering.
5. Gas Storage Field Personnel.
6. Corrosion Control.
7. Ameren Illinois Call Center
8. Distribution Control - Gas Dispatch

5.4 If Gas Control is requested to provide monitoring, Gas Control shall be notified before and after the project.

6.0 Records

6.1 Retire all abandoned distribution and transmission mains in Ameren Illinois electronic gas mapping system.

6.2 Retain information on the abandoned facilities in Maximo.

End of Instructions.

Operator Qualification (OQ) Required?

YES.

UNCONTROLLED IF PRINTED

A002: Abandonment

1371: Operate Gas Pipeline - System Control Center Operations

Appendices

NONE.

Attachments

NONE.

Compliance Requirements

49 CFR §192.727 Abandonment of facilities.

Reference Documents

[PRES 2.1 Pressure Monitoring: Potential Over Pressurization or Service Interruption.](#)

[PURG 1 Purging: Requirements Section 6.0 Purging Transmission Lines High Pressure Distribution Mains.](#)

[PURG 2 Purging: Methods Section 6.0 Purging of Gas with Air During Abandonment.](#)

Document Rescission

ABND 1 Abandonment of Facilities: Requirements, April 1, 2021.

Revision Notes

Location of Changes	Summary of Changes
Target Audience	Added Gas Control
Operator Qualifications	Added 1371 - System Control Center Operations

ABANDONMENT OF FACILITIES

October 1, 2022

ABND 2.1 Abandonment of Gas Facilities

1.0 Purpose

This document provides the requirements for abandoning natural gas transmission, high pressure distribution, and distribution facilities including services, regulator stations, farm taps, inside meters, and vaults in accordance with 49 CFR §§ 192.475 and 192.727.

2.0 Scope

This document addresses the following:

[3.0 Target Audience](#)

[4.0 Abandonment - General](#)

[5.0 Transmission Lines and Distribution Mains](#)

[6.0 Services](#)

[7.0 Inside Meters](#)

[8.0 Verification of Main or Service Status](#)

[9.0 Commercially Navigable Waterways](#)

[10.0 Vaults](#)

[11.0 Records](#)

Attachments

[Attachment 1 - Continental Abandonment Kit Instructions.](#)

[Attachment 2 - Mueller Steel Abandonment Cap for H-17800 Curb Stop Tees.](#)

[Attachment 3 - Polywater AFT Sealant.](#)

3.0 Target Audience

- Distribution Design.
- Gas Engineering.
- Gas Supervisor.
- Gas Field Personnel.
- Gas Tech Engineering (GTE).
- Gas Tech Services (GTS) Supervisor.
- Gas Tech Services (GTS) Personnel.
- Gas Storage Engineering.
- Gas Storage Field Supervisors.
- Gas Storage Field Operators.
- Gas Construction Services Supervisors.

4.0 Abandonment - General

4.1 Abandonment means permanently removed from service. (§192.3).

4.2 Abandon inactive pipelines that are not maintained. (§192.727(c)).

4.3 See the following resources when pipeline facilities may have or contain materials requiring special handling.

4.3.1 [MAIN 2.5](#) Pipe Coating and Gasket Removal.

UNCONTROLLED IF PRINTED

4.3.2 [PCBH 1](#) PCB Handling: Requirements.

5.0 Transmission Lines and Distribution Mains (§192.727(b))

5.1 General.

- 5.1.1 Identify all the sources of gas feeding into the section of transmission line or distribution main to be abandoned. If there is a two-way feed or more into that section:
1. Pressure gauges will be installed to monitor the pressure of the remaining system and the section of main to be retired.
 2. Gauges shall be monitored to ensure there is not an unplanned interruption of service. See [PRES 2.1 Section 5.0](#) Pressure Monitoring While Performing Work Activities.
- 5.1.2 Install an electrical bond prior to any cutting on steel pipe. See [ACIG 2 Section 6.0](#) Welding and Other Hot Work.
- 5.1.3 Shut off the gas flow from all sources of gas supply to the main being abandoned using one of the following:
1. Line stopper fitting. See [TAPS 1](#) Tapping and Stopping.
 2. Valve.
 3. Squeeze off. See [POLY 2.2](#) Squeeze Off when squeezing off PE main.
- 5.1.4 Purge the transmission line or distribution main to be abandoned of gas. See [PURG 2 Section 6.0](#). Purging of Gas with Air During Abandonment.
- 5.1.5 Remove a section of pipe between the pressurized section(s) and the section being abandoned.
- 5.1.6 Inspect the abandoned steel pipe for evidence of internal corrosion. (§192.475) See [CORR 1 Section 10.0](#) Internal Corrosion Inspection.
1. Perform a corrosion evaluation if evidence of internal corrosion is present. See [CORR 1 Appendix B](#) - Corrosion and Steel Damage Evaluation Form.
- 5.1.7 Following installation of a welded, threaded, or fusion cap or a blind flange on the remaining live stub:
1. Introduce gas under normal operating pressure.
 2. Check the connection for leaks with leak detection fluid or a leak detection instrument.
 3. Record this leak test on the DOJM or As-Built plans and retain it in the permanent job file.
- 5.1.8 Coat the pressurized stubs of steel pipe with an approved coating. See [CORR 2.3 Section 4.0](#) Approved Coatings.
- 5.1.9 Leave fitting closed once abandonment is complete if the fitting used to shut-off the gas supply is:
1. Equipped with a stem which seats closed within the fitting.
And
 2. Does not have an internal cutter/punch assembly.

5.1.10 Seal all open ends of the abandoned pipe, including side outlets, former lateral connections, and disconnected service taps with one of the following:

1. Expanding polyurethane foam.
2. Expander plug.
3. Threaded cap.
4. Welded cap.

5.1.11 Remove valve boxes or drive valve boxes below grade and backfill with suitable material whenever possible.

5.1.12 If the valve box cannot be removed or driven below grade, remove the lid and fill the valve box with:

- Dirt,
- Other suitable material.
- Concrete,
Or
- Rock,
- Sand,

5.1.13 Leave the valve box lid off after abandonment.

5.1.14 Notify Gas Tech Engineering if the transmission line or distribution main is located under a navigable waterway. See [Section 9.0](#).

5.2 PE Mains.

5.2.1 Permanently seal all open ends of pressurized PE mains.

1. For PE mains 1¼ inch and larger use an approved PE fusion cap.
2. For PE mains 1 inch and smaller use a stab or fusion cap.

5.2.2 Cut the tracer wire as close as possible at the connection. Protect the cut end of the tracer wire at the main by one of the following:

1. Wrap it with vinyl mastic tape (Stock Code 25 53 225).
2. Encase it in a splice box (Stock Code 49 62 001).
3. Verify that the tracer wire cannot be pulled out of the splice box.

5.3 Steel Transmission Lines and Distribution Mains.

5.3.1 Permanently seal all open ends of pressurized steel lines or mains. Use one of the following that is properly sized and pressure rated:

1. Welded steel cap.
2. Blind flange.
3. A threaded cap may be installed on mains smaller than 2 inches.

5.3.2 Remove bonds between retired sections and any cathodic protection structures.

1. Notify Corrosion Control personnel for the area when the bond is removed to ensure the integrity of remaining cathodic protection structure.
2. If the bond was with a foreign structure, Corrosion Control shall notify the owner of that structure.

5.4 Regulator Stations.

- 5.4.1 Remove all above ground piping associated with a permanently abandoned regulator station.
- 5.4.2 Seal all retired piping that remains in the ground in accordance with applicable procedures contained in this section.
- 5.4.3 Treat any pressurized mains remaining in same manner as described in [this section](#).
- 5.4.4 If regulator station is in a vault or pit, see [Section 10.0](#) for abandonment of the vault or pit.

6.0 Services (§192.727(d))

6.1 General.

- 6.1.1 For discontinuance of service to customer, see [TURN 2.3 Section 7.0](#) Hard Disconnect.
- 6.1.2 Install an electrical bond prior to any cutting on steel pipe. See [ACIG 2 Section 6.7](#) Welding and Other Hot Work.
- 6.1.3 Disconnect the abandoned service from all sources of gas supply. Shut off the gas supply using one of the following:
 1. Service tee.
 2. Manual service line shut-off valve.
 3. Line stopper fitting. See [TAPS 1](#) Tapping and Stopping.
 4. Squeeze off. See [POLY 2.2](#) Squeeze Off when squeezing off PE service line.
- 6.1.4 Disconnect services within 18 inches of the main whenever possible. If the service stub exceeds 18 inches, it shall be documented. See [Section 11.0](#).
- 6.1.5 Retire PE services 2 inches and larger with inline tee or side saddle connections in the same manner as main. See [Section 5.1](#).
- 6.1.6 For PE service line with tapping tee connection:
 1. Run down the service tee punch.
 2. Install an electrofusion, butt fusion, or stab cap on the remaining pressurized section of the PE service line.
 3. Stab caps can be used on ½-inch thru 1-inch PE service lines.
 4. See:
 - [POLY 2.4](#) Butt Fusion,
 - [POLY 2.5](#) Electrofusion, Or
 - [POLY 2.6](#) Mechanical Joining for installation procedures.
- 6.1.7 For a PE service line that has an existing EFV:
 1. Cut off the EFV so that the remaining stub is less than 18 inches if the remaining stub is of sufficient length to allow for proper installation of a fusion or stab cap.
 2. If there is not sufficient length available, the cap shall be installed downstream of the EFV and as close as feasibly possible to the EFV.

3. See:
 - [POLY 2.4](#) Butt Fusion,
 - [POLY 2.5](#) Electrofusion, Or
 - [POLY 2.6](#) Mechanical Joining
- 6.1.8 Following installation of the cap:
 1. Introduce gas under normal operating pressure into the remaining stub.
 2. Check the cap connection checked for leaks with leak detection fluid or a leak detection instrument.
- 6.1.9 Coat the steel service stub with an approved coating. See in [CORR 2.3 Section 4.0](#) Approved Coatings.
- 6.1.10 If service tap is not accessible or the service line is being abandoned along with the main, the tap shall remain in the open position.
- 6.1.11 Service lines that are:
 1. Two inches or larger in nominal diameter shall be purged as main when the service line is:
 - 1 a. 500 feet or longer and operating at 100 psig or less, or
 - 1 b. 100 feet or longer and operating above 100 psig.
 - 1 c. See [PURG 2 Section 6.0](#) Purging of Gas with Air During Abandonment.
 2. Smaller than 2 inches nominal diameter and shorter than 500 feet do not have to be purged due to the size of pipe and small volume of gas present at atmospheric pressure.
- 6.1.12 Inspect abandoned steel service lines for evidence of internal corrosion. (§192.475) See [CORR 1 Section 10](#). Internal Corrosion Inspection.
- 6.1.13 Seal all open ends of abandoned service lines before introducing an ignition source (e.g. welding, cadweld, hot wrap, etc.) near the end of the service line. Seal the open ends of an abandoned service line using one of the following:
 1. Expanding polyurethane foam.
 2. Expander plug.
 3. An approved cap (e.g. PE stab or fusion cap; steel threaded or welded cap).
- 6.1.14 If the PE service is being abandoned with the main, the tracer wire does not need to be cut-off close to the main connection. Otherwise, cut the tracer wire for PE service as close as possible at the main. Protect the cut end of the tracer wire at the main by one of the following:
 1. Wrap it with vinyl mastic tape (Stock Code 25 53 217).
 2. Encase the tracer wire in a splice box (Stock Code 49 62 001).
 3. Verify that the wire cannot be pulled out of the splice box.
- 6.1.15 Certain steel tees shall be retired by utilizing the MAZCO tool. Contact Gas Standards and Procedures at 217-535-5069 for approved applications and qualification requirements.
- 6.1.16 Remove above ground piping.

UNCONTROLLED IF PRINTED

Always verify that a riser is on an abandoned service line before cutting.

1. The riser shall be removed to a minimum of 6 inches below grade. If the riser is encased in concrete or asphalt, it can be cutoff at the surface and sealed with an expander plug or an approved cap.
2. Customer side above grade piping shall be removed back to the fitting closest to the structure. Customer pipe shall be capped or plugged.

6.1.17 Remove valve boxes or drive valve boxes below grade and backfill with suitable material whenever possible.

6.1.18 If the valve box cannot be removed or driven below grade, remove the lid and fill the valve box with:

- Dirt,
- Other suitable material.
- Concrete, Or
- Rock,
- Sand,

6.1.19 Leave the valve box lid off after abandonment.

6.1.20 The retirement of the service and the leak test shall be recorded in the Service Card module within ClickMobile.

6.2 PE Service Lines with Compression or Stab Outlet Tees.

6.2.1 1/2" CTS PE service lines being retired from a Continental tee with a compression outlet, shall be retired using the Continental abandonment kit (Stock Code 19 72 160). See [Attachment 1](#) for instructions.

6.2.2 For PE service lines 1" and smaller with an outlet stab fitting, cut off the stab fitting at the butt fusion joint if a long enough stub exists to allow for the proper installation of an electrofusion cap. See [POLY 2.5](#) Electrofusion.

6.2.3 Service taps with an internal cutter/punch assembly shall be left in the down position on steel distribution mains with MAOP of 100 psig or less once the abandonment is complete.

1. In order to leak test the cap connection, run the tee up to allow gas to enter the service stub then return the tee to the down position.

6.3 Steel Service Lines.

6.3.1 Run the punch down on steel service lines having a service tee containing a punch.

1. If complete shutdown is obtained, an approved steel cap shall be installed on the remaining pressurized section of steel service line.

6.3.2 Service taps with an internal cutter/punch assembly shall be left in the down position on steel distribution mains with MAOP of 100 psig or less once the abandonment is complete.

1. In order to leak test the cap connection, run the tee or punch up to allow gas to enter the service stub.

UNCONTROLLED IF PRINTED

- 6.3.3 A service tee that does not contain a punch but does have a completion plug shall be stopped off in accordance with the proper Mueller or T.D. Williamson procedure. See [TAPS 3](#). Forms and Reference Materials for procedures.
- 6.3.4 Shutting down a steel service line not having:
1. An accessible service tee,
Or
 2. A service tee containing a punch or completion plug,
Or
 3. A complete shutdown is not obtained in [6.3.1](#) above,
Then:
 4. Shutdown may be obtained by the following methods:
 - 4 a. Install a line stopper fitting on the service line to obtain complete shut-down and then install an approved steel cap. See [TAPS 1](#) Tapping and Stopping.
 - 4 b. Shut down the section of main where the service is located to stop the flow of gas to the service and the cap the service line stub with an approved steel cap.
- 6.3.5 Transmission and steel high pressure distribution mains need to be free of obstructions so that a pig can be run through the line.
1. Any service tap that has an internal cutter/punch shall be left in the up position after abandonment is complete.
 2. If the service tap is equipped with a stem which seats closed within the fitting and not an internal cutter/punch assembly, it shall be left in the closed position once the abandonment is complete.
- 6.3.6 Cap the pressurized service line stub. Use one of the following that is properly sized and pressure rated:
1. Welded steel cap.
 2. Blind flange.
 3. A threaded cap can be installed on services smaller than 2 inches.
- 6.3.7 Service tees with a compression outlet shall have capped pipe or properly sized solid plug inserted into the outlet.
1. If the solid plug is not restrained with a cap, the outlet shall be strapped to prevent movement of the capped pipe or plug.
- 6.3.8 Steel service line with an EFV:
1. Cut off the EFV to allow the service length to remain under 18 inches provided the remaining stub is of sufficient length to allow for proper installation of an approved steel cap.
 2. If there is not sufficient length, the cap shall be installed downstream of the EFV and as close as feasibly possible to the EFV.
- 6.3.9 Mueller has a Steel Abandonment Cap for the H-17800 Curb Stop/Valve Tee. The Steel Abandonment Cap can be used to replace a leaking Curb Stop/Tee cap. See [Attachment 2](#) for installation instructions.

Table 1: Mueller Abandonment Caps for H-17800 Curb Stop Tee		
Stock Number	Description	Size
19 33 706	Cap, Mueller Tee Retirement	2 inches
19 33 707	Cap, Mueller Tee Retirement	1 inch
19 33 708	Cap, Mueller Tee Retirement	1¼ inches

6.3.10 Service line being abandoned as part of an active joint mains and services abandonment project, the squeezed off section of the service line shall have an approved steel threaded or welded cap installed.

6.4 Farm Taps.

6.4.1 Remove all above ground piping associated with a permanently abandoned farm taps.

6.4.2 Seal all retired piping that remains in the ground in accordance with [Section 6.0 Services](#).

6.4.3 Treat any remaining pressurized service line in the same manner as Service Lines in [Section 6.0 Services](#).

7.0 Inside Meters

7.1 Remove all unused piping and fittings inside the structure, if feasible.

7.2 Seal open end of service with an expander plug, an approved cap, or approved cement material. Both may be inserted from inside the building.

7.3 If the pipe size and material allow for installation of an approved threaded cap, a cap shall be installed just inside structure at point of entry.

Consideration shall be given to customer's request for an alternative method of sealing the pipe end.

7.4 Service line that enters the building wall above grade shall be cut off and an approved threaded or welded cap installed as close as possible to the outside wall. Outside piping shall be removed and sealed in the same manner as a service riser. See [Section 6.1.16](#).

7.5 Service line entering the structure below grade and cut-off outside of the structure wall, shall have an approved cap of like material installed on the stub going through the wall as close to the wall as possible. The other open end of the abandoned service line shall be sealed in the same manner as indicated in [Section 6.1.13](#).

8.0 Verification of Main or Service Status

If the status of an existing main or service line cannot be confirmed through records, the options in [Section 8.1](#), [Section 8.3](#), and [Section 8.4](#) are available for checking whether or not there is gas present in the line.

- 8.1 Initially check to see if the main or service has connectivity to the known active gas system by:
- 8.1.1 Connecting a pipe locator to the pipe in question or to an active nearby gas facility. See [LOCT 1](#) Locating: Methods.
 - 8.1.2 Checking the pipe in question for a P/S reading. Reading of less than -700 mv may indicate an abandoned main or service. Contact a Corrosion Control Technician to validate that the segment is not part of an active cathodically protected system.

Corrosion Control Technicians have the ability and instruments (e.g., short locator or current interrupter) to determine if the pipe is connected to an active system.

The following options are dependent on the possibility that the existing pipe could have an inserted live gas line.

- 8.2 The possible maximum operating pressure on the main or service shall be verified before tapping into the pipe by verifying the MAOP of the other live gas lines in the vicinity.
- 8.3 If there is no possibility of the pipe in question having a live line inserted in it, there are two options available:
- 8.3.1 The first option is to install a service tee on the line, tap the service tee to see if there is gas present.
 - 1. Follow the same procedures required when installing a service tee on a live pipeline.
 - 2. If there is gas present when the line is tapped, the outlet of the service tee shall be properly capped and abandoned.
 - 3. If there is no gas present, the outlet of the service tee shall be sealed with expanding polyurethane foam, expander plug, or an approved cap.
 - 4. The second option is to drill a small hole through the pipe wall using an intrinsically safe drill with a small bit, minimum 1/8 inch.

Be extremely careful not push too hard on the drill when drilling because the inserted pipe that may be present could be damaged by the drill bit.

- 5. The individual drilling the hole shall be dressed in Level I PPE. See [WIGE 2.2](#) Personal Protective Equipment.
- 6. Prior to drilling the hole, a properly sized and pressure rated steel clamp shall be loosely installed on the pipe and positioned to where it can be slid over the hole if there is gas on the pipeline.

7. Once a hole has been drilled through the pipeline wall and no gas is present, a thin object such as tracer wire, marker flag staff, or welding rod can be inserted through the hole to check for an inserted pipe.
 8. If pipeline is dead, the hole shall be sealed with the clamp.
 9. If gas is present, a permanent repair will be required. See:
 - 9 a. [REPR 1 Appendix B](#) - Steel Distribution Pipe Repairs.
 - Or
 - 9 b. [REPR 1 Appendix E](#) - PE Pipe Repairs.
 10. Ensure the gas is under expected operating pressure and not residual gas remaining in the pipeline.
- 8.4 If there is a possibility of insertion, the existing pipeline can be drilled using an intrinsically safe drill with a small bit, minimum 1/8 inch. For the steps to follow, see Section [8.3.1.4](#) through Section 8.3.1.10, above.

9.0 Commercially Navigable Waterways (§192.727(g))

- 9.1 Gas Operations and Services shall report abandoned pipeline facilities that cross over, under, or through a commercially navigable waterway.
- 9.2 Submit data on pipeline facilities abandoned after October 10, 2000 to the National Pipeline Mapping System (NPMS) in accordance with the NPMS "Standards for Pipeline and Liquefied Natural Gas Operator Submissions."
- 9.3 A copy of the NPMS Standards can be obtained at www.npms.PHMSA.dot.gov or by contacting the NPMS National Repository at 703-317-3073.
- 9.4 The NPMS Standards provide details for preparing data for submission as well as details on how to submit the data.
- 9.5 Digital data format is preferred, but hard copy submissions are acceptable if they comply with the NPMS Standards.
- 9.6 Reports may be submitted by mail, fax, or e-mail to the Office of Pipeline Safety, Pipeline and Hazardous Materials Safety Administration, U.S. Department of Transportation, Information Resources Manager, PHP-10, 1200 New Jersey Avenue, SE., Washington, DC 20590-0001; fax (202) 366-4566; e-mail InformationResourcesManager@PHMSA.dot.gov.

The report must contain the location, diameter, date of abandonment, method of abandonment, and a certification that the facility was abandoned in accordance with all applicable laws.

10.0 Vaults (§192.727(f))

- 10.1 Concrete and masonry vaults/pits shall have tops removed and the side walls removed, at a minimum, one foot below grade.
 - 10.1.1 If vault/pit has a concrete/solid floor, bust out a hole in the floor to provide a drain.
 - 10.1.2 Fill the vault/pit with soil, sand, or crushed stone with the top 12 inches, at a minimum, of compacted soil.

UNCONTROLLED IF PRINTED

10.1.3 If the vault/pit was located in a hard surface area, such as concrete or asphalt, cap the hole with the appropriate hard surface material.

11.0 Records

11.1 Update the main record(s) to document the retirement and leak test performed to check the capping of the pressurized main. Update the Ameren Illinois (AIC) electronic gas mapping system to reflect the abandonment.

11.2 If the remaining service stub is longer than 18 inches, indicate such in AIC's electronic mapping system.

11.2.1 Use the "Miscellaneous Text" annotation on the segment of the main to which the stub is tied. Place an annotation showing the stub's:

- Length.
- Location (e.g. 35' E. of CL N. 16th St.).
- Diameter.

11.2.2 See example annotations on Figure 1.

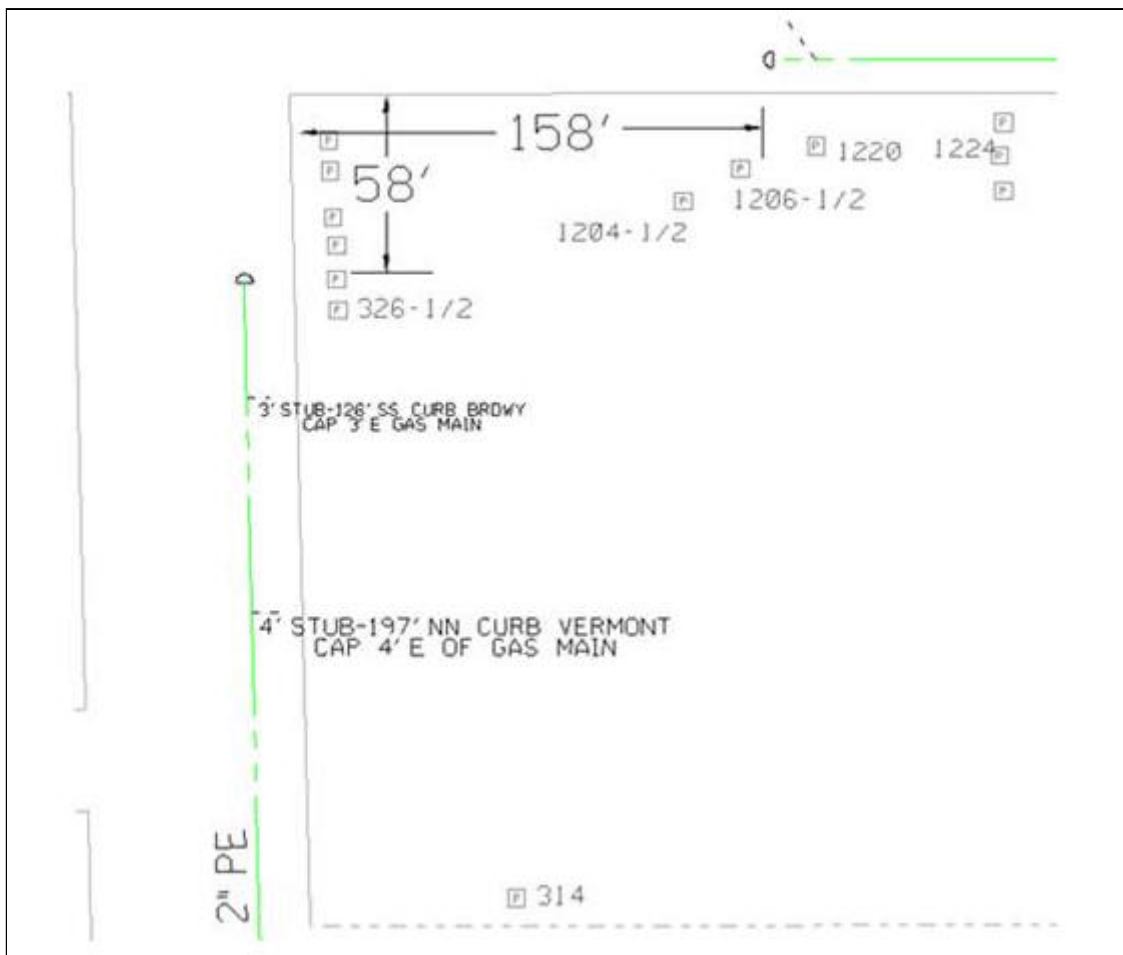

Figure 1: Examples of Miscellaneous Text Annotations for Stubs and Caps

11.2.3 In ClickMobile, indicate a full retirement on the service record, but the 'stub greater than 18 inches' box shall be checked.

11.3 Update the service record card within ClickMobile to document the retirement and leak test performed to check the capping of the pressurized stub.

- 11.4 Buried Pipe Examination Form shall be completed within ClickMobile to report condition of the remaining pressurized main(s) and/or service line(s). See [CORR 1 Appendix A - Buried Pipe Examination](#).
- 11.5 If there is evidence for internal corrosion it shall be documented on the Corrosion and Steel Damage Evaluation form within ClickMobile. See [CORR 1 Appendix B - Corrosion and Steel Damage Evaluation](#).

End of Instructions.

Operator Qualification (OQ) Required?

YES.

A002: Abandonment.

Appendices

NONE.

Attachments

[Attachment 1 - Continental Abandonment Kit Instructions](#). (PDF file)

[Attachment 2 - Mueller Steel Abandonment Cap for H-17800 Curb Stop Tees](#). (PDF file)

[Attachment 3 - Polywater AFT Sealant](#). (PDF file)

Compliance Requirements

49 CFR §192.475 Internal corrosion control: General.

49 CFR §192.727 Abandonment of facilities.

Reference Documents

[ACIG 2 Accidental Ignition: Work Area Protection, Section 6.0 Welding and Other Hot Work](#)

[CORR 1 Corrosion Control: Requirements](#)

[Section 9.0 Buried Pipe Examination](#)

[Section 10.0 Internal Corrosion.](#)

[Appendix B Corrosion and Steel Damage Evaluation](#)

[CORR 2.3 Corrosion Control: Coatings, Section 4.0 Approved Coatings](#)

[LOCT 1 Locating: Methods](#)

[MAIN 2.5 Main Installation: Pipe Coating and Gasket Removal](#)

[PCBH 1 PCB Handling: Requirements](#)

[POLY 2.2 Polyethylene Pipe: Squeeze Off](#)

[POLY 2.4. Polyethylene Pipe: Butt Fusion](#)

[POLY 2.5 Polyethylene Pipe: Electrofusion](#)

[POLY 2.6 Polyethylene Pipe: Mechanical Joining](#)

UNCONTROLLED IF PRINTED

PRES 2.1 Pressure Monitoring: Potential Over Pressurization or Service Interruption

Section 5.0 Pressure Monitoring While Performing Work Activities

Section 8.0 Activities Requiring an Operational Checklist.

PURG 1 Purging: Requirements Section 6.0 Purging Transmission Lines and High Pressure Distribution Mains

PURG 2. Purging: Methods Section 6.0 Purging: Purging of Gas with Air During Abandonment.

REPR 1 Repairs: Requirements

Section 8.0 Steel Distribution.

Section 9.0 Polyethylene (PE) Pipe Repair.

TAPS 1 Tapping and Stopping:Requirements.

TAPS 3 Tapping and Stopping: Forms and Reference Materials

TURN 2.3 Turn-on Turn-off: Discontinuance or Transfer of Gas Service, Section 7.0 Hard Disconnect.

WIGE 2.2 Working In Gaseous Environment: Personal Protective Equipment.

Document Rescission

ABND 2.1 Abandonment of Facilities: Abandonment of Gas Facilities, April 1, 2021.

Location of Changes	Summary of Changes
Subsection 11.2	Update: service stub longer than 18 inches is to be mapped in AIC's electronic mapping system. Change required to be consistent with ClickMobile instructions and Paragraph 6.1.4

ACIG-Accidental Ignition

ACCIDENTAL IGNITION

October 1, 2020

ACIG 0 -Table of Contents

[ACIG 1 Accidental Ignition: Requirements](#)

Section 1.0 Purpose
Section 2.0 Scope
Section 3.0 Target Audience
Section 4.0 Sources of Ignition
Operator Qualification
Compliance Requirements
Reference Documents
Document Rescission

[ACIG 2 Accidental Ignition: Work Area Protection](#)

Section 1.0 Purpose
Section 2.0 Scope
Section 3.0 Target Audience
Section 4.0 General
Section 5.0 Tools and Equipment
Section 6.0 Welding and Other Hot Work
Section 7.0 Working with Plastic Pipe
Section 8.0 Isolating Pipeline Segments on Planned Work to Minimize the Potential of Ignition
Operator Qualification
Compliance Requirements
Reference Documents
Document Rescission

End Table of Contents.

Document Rescission

ACIG 0 Accidental Ignition: Table of Contents, January 1, 2011.

Revision Notes

UNCONTROLLED IF PRINTED

Location of Changes	Summary of Changes
Not applicable.	This is a new document.

ACCIDENTAL IGNITION

April 1, 2023

ACIG 1 Requirements

1.0 Purpose

This document prescribes the steps required to minimize the risk of accidental ignition in any structure or area where the presence of natural gas constitutes a hazard of fire or explosion in accordance with 49 CFR §192.751.

2.0 Scope

This document addresses the following:

[3.0 Target Audience](#)[4.0 Sources of Ignition](#)**3.0 Target Audience**

- Gas Engineering
- Gas Field Personnel
- Gas Supervisors
- Gas Tech Engineering (GTE)
- Gas Tech Services (GTS) Supervisors
- Gas Tech Services (GTS) Personnel
- Gas Storage Field Supervisors
- Gas Storage Field Operators
- Gas Construction Services Supervisors
- Gas Construction Inspectors
- Gas Construction Contractor Supervisors

4.0 Sources of Ignition (§192.751(a))

Employees shall know the causes of accidental ignition and how to avoid their effects. These causes and avoidance procedures may include:

4.1 Smoking and Open Flames

4.1.1 Smoking, the use of vaping devices, and open flames are prohibited in:

1. Structures containing gas facilities where possible leakage and/or the presence of gas exists.
2. Open areas containing gas facilities when the possibility of accidental ignition of a gas-in-air mixture exists.

4.2 Mechanical Sparking and Electric Arcing

4.2.1 Where the possibility of accidental ignition of a gas-in-air mixture exists, use only **flashlights**, **work** lights, tools, **equipment** and communication devices that **are labelled or certified as intrinsically safe** and approved for use in a **Class 1 Division 1** hazardous environments.

1. Class 1 the environment contains flammable gases, vapors, and liquids
2. Division 1 an environment where ignitable gases, vapors, or liquids can exist under normal conditions, maintenance work, or because of leakage.

4.2.2 Do not use on/off switches or make electrical connections and disconnections in hazardous environments.

4.3 Static Electricity Arcing

UNCONTROLLED IF PRINTED

- 4.3.1 Install an electric bond across the area of the **steel** pipe to be cut or separated.

Maintain the bond until all reconnections are complete or a gas free environment exists.

- 4.3.2 **Ground the squeeze-off tool prior to squeezing off PE pipe. See [POLY 2.2 Sub-section 5.1](#) Before Starting Squeeze-off, for eliminating external static charge on 1-1/4 inches PE pipe and larger.**

Where possible, use a separate excavation in a gas free environment when squeezing off plastic pipe.

- 4.3.3 Use grounded, metallic pipe for purge vents during purging operations. See [PURG 2](#) Purging: Methods.

4.4 Internal Combustion Engines

- 4.4.1 Limit the use of internal combustion engines where the possibility of accidental ignition of a gas-in-air mixture exists.

Position cars, trucks, excavation equipment, compressors, generators, pumps, welding machines, etc., a safe distance upwind from the blowing gas.

4.5 Overhead Electric Lines

- 4.5.1 Follow the procedures in [CORR 2.6](#) AC Interference on Buried Pipelines and Stray Current prior to working on gas facilities under or in close proximity to overhead electric lines.

Overhead electric lines can produce arcing by:
- Inducing a voltage onto a pipeline. - Conducting a voltage and current caused by lightning or a ground fault.

4.6 Lightning

- 4.6.1 Do not preform purging and blowdown operations when there is lightning in the area.

End of Instructions.

Operator Qualification (OQ) Required?

NO.

Appendices

NONE.

Attachments

NONE.

Compliance Requirements

49 CFR §192.751 Prevention of accidental ignition.

Reference Documents

[CORR 2.6 Corrosion Control: AC Interference on Buried Pipelines and Stray Current](#)

[POLY 2.2 Polyethylene Pipe: Squeeze Off](#)

[PURG 2 Purging: Methods.](#)

Document Rescission

ACIG 1 Accidental Ignition: Requirements, October 1, 2021.

Revision Notes

Location of Changes	Summary of Changes
Paragraph 4.2.1 - Intrinsically Safe	<p>Revised – Where possibility of accidental ignition of a gas-in-air mixture exists, use only flashlights, work lights, tools, equipment, and communication devices that are labelled or certified as intrinsically safe and approved for use in a Class 1 Division 1 hazardous environment.</p> <p>1. Class 1 the environment contains flammable gases, vapors, and liquids</p> <p>2, Division 1 an environment where ignitable gases, vapors, or liquids can exist under normal conditions, maintenance work, or because of leakage.</p>
Paragraph 4.2.1	Remove Table 1 that list types of intrinsically safe devices. Listed power tools and electronics are completely intrinsically safe.
Paragraph 4.2.2	Removed Table 2 that listed devices not to use in a hazardous environment unless they are intrinsically safe.
Paragraph 4.3.1	Added the word "steel" to clarify an electric bond is used on steel pipe.
Paragraph 4.3.2	Grammatical revision – Ground the squeeze-off tool prior to squeezing off PE Pipe. See POLY 2.2 Subsection 5.1 Before Starting Squeeze-off for eliminating external static charge on 1-1/4 inches PE pipe and larger.

ACCIDENTAL IGNITION

April 1, 2023

ACIG 2 Work Area Protection**1.0 Purpose**

This document prescribes the steps that are required to minimize the risk of accidental ignition in any structure or area where the presence of gas constitutes a hazard of fire or explosion in accordance with 49 CFR §192.751 and 29 CFR §1926.651(g)(1)(i).

2.0 Scope

This document addresses the following:

[3.0 Target Audience](#)**[4.0 General](#)****[5.0 Tools and Equipment](#)****[6.0 Welding and Other Hot Work](#)****[7.0 Working with Plastic Pipe](#)****[8.0 Isolating Pipeline Segments on Planned Work to Minimize the Potential of Ignition](#)****3.0 Target Audience**

- Gas Engineering.
- Gas Field Personnel.
- Gas Supervisors.
- Gas Tech Engineering (GTE).
- Gas Tech Services (GTS Supervisors)
- Gas Tech Services (GTS) Personnel.
- Gas Storage Field Supervisors
- Gas Storage Field Operators
- Gas Construction Services Supervisors
- Gas Construction Inspectors
- Gas Construction Contractor Supervisors
- Gas Control

4.0 General (§192.751(c))

4.1 Secure the work area through the use of the following when uncontrolled blowing gas is present.

4.1.1 See **[WIGE 2.1](#)** Hazardous Environment for:

1. Identifying a hazardous outdoor environment.
2. Establishing a safe zone.
3. Working in a hazardous outdoor environment.

4.1.2 Items for securing and visually marking include, but are not limited to:

- Barricades.
- Caution tape.
- Cones.
- Fencing.
- Marking paint.
- Signs (e.g., detour, road closed).

4.1.3 Personnel for marking and securing the area include, but are not limited to:

1. Qualified Emergency Responders (See **[EMER 2.3](#)** Emergency Responder).

UNCONTROLLED IF PRINTED

2. Law enforcement.
3. Traffic flaggers.

The intent of deploying any of the above steps is to keep public motor vehicle and pedestrian traffic away from the potential hazard.

- 4.2 See [ACIG 1](#) Accidental Ignition: Requirements to minimize the dangers of accidental ignition during repair operations and procedures.

5.0 Tools and Equipment (§192.751(a))

Gas Field Personnel shall use tools and equipment that are intrinsically safe and approved for use in hazardous environments. See [ACIG 1](#).

- 5.1 The following equipment shall be placed at a safe distance upwind from blowing gas:

- Air compressors.
- Cars.
- Excavation equipment.
- Generators.
- Trucks.
- Water pumps.
- Welding machines.
- Other portable equipment.

- 5.2 Locate a Vapor Extraction Unit (VEU) in the work area where the gas concentration is safe for open ignition sources.
 - 5.2.1 The VEU shall be equipped with preventative safety devices to ensure explosive levels of natural gas are not pulled through the unit.
 - 5.2.2 The safety devices shall be calibrated, and the unit operated in accordance with the manufacturer's operating instructions.
- 5.3 Locate VEU or Compression System (ZEVAC) air/gas vent seat at least 15 feet away from the air compressor or other ignition sources.
- 5.4 Locate ventilating equipment used to move air containing natural gas to where the gas concentration is safe for open ignition sources.
- 5.5 At least 1 fire extinguisher shall be on the jobsite and upwind from the work area. See [EXCV 2.9](#) Working in Hazardous Environment.

6.0 Welding and Other Hot Work §192.751 and §1926.651(g)(1)(i)

- 6.1 Prior to welding or other hot work in or around a structure, area, or excavation containing gas facilities:
 - 6.1.1 Evaluate the environment for the presence of natural gas, oxygen, and carbon monoxide.
 - 6.1.2 Use a checked and calibrated CGI. See [LEAK 2.5 Section 6.0](#) Combustible Gas Indicator (CGI).

Additional testing may be needed if other toxic gases, such as hydrogen sulfide, are suspected to be present. Contact Safety Supervisor if other sampling is needed.

- 6.2 No welding or other hot work operations shall be conducted within a structure, area, or excavation if its environment meets one of the criteria below. See [EXCV 2.9](#) Working in Hazardous Environment.
 - 6.2.1 When the concentration of natural gas is 30% LEL (1.5% gas-in-air) or greater.
 - 6.2.2 When the oxygen level is 19.5% or less.
 - 6.2.3 When carbon monoxide and other toxic gases are present.
- 6.3 If any of the criteria in 6.2 are met for a structure, area, or excavation, ventilating equipment shall be used to:
 - 6.3.1 Reduce the concentration of natural gas to less than 30% LEL.
 - 6.3.2 Increase the oxygen level to more than 19.5%.
 - 6.3.3 Dilute carbon monoxide and other toxic gases.
- 6.4 A Qualified Field Gas Person shall check and monitor the environment in the immediate area where the work is being done until the work is complete. See [EXCV 2.9](#) Working in Hazardous Environment.

Ventilating equipment may be needed until the work is complete. For other solutions see [EXCV 2.9](#) Working in Hazardous Environment and [WIGE](#) Working In Gaseous Environment.

- 6.5 Gas in an excavation with steel pipe may be flashed (ignited) to ensure that a hazardous concentration has not accumulated prior to welding.
- 6.6 Minimize the possibility of creating a combustible gas-in-air mixture during welding operations by:
 - 6.6.1 Keeping the pipeline or main either full of gas or completely purged of gas;
 - 6.6.2 Maintaining a slight flow of gas moving toward the welding operation and flashing (igniting) the gas either through a metallic stack or at the weld prior to welding;
 - 6.6.3 Closing all open ends with tape, a cap, or plugging material immediately after a cut is made;
 - 6.6.4 Purging a main with inert gas (nitrogen) or air;
 - 6.6.5 Ensuring that two openings shall not left open at the same time unless the line has been completely purged of natural gas;Or
 - 6.6.6 Extracting the gas from the main with a vacuum purge or air mover. See [PURG 2](#) Purging: Methods - Vacuum Purge/Air Mover.

- 6.7 Install an electric bond prior to cutting steel gas piping. Maintain the bond until all recon-nections are complete or a gas free environment exists.

Install bond cables in a manner that ensures they do not become dislodged during work and they provide minimal electrical resistance between pipe sections.

7.0 Working with Plastic Pipe (§192.751(b))

- 7.1 Ground the squeeze-off tool prior to squeezing off PE pipe.
- 7.2 Refer to **POLY 2.2 Subsection 5.1** Before Starting Squeeze-off for additional steps for eliminating external static charge on 1-1/4 inched PE pipe and larger.
- 7.3 Maintain the ground until the squeeze tool is removed.

Where possible, use a separate excavation in a gas free environment when squeezing off plastic pipe.

- 7.4 Metallic pipe shall be used for purge vents and shall be grounded during purging operations. For purge pipe length, see **PURG 2**. Purging: Methods.

8.0 Isolating Pipeline Segments on Planned Work to Minimize the Potential of Ignition (§192.751(b))

- 8.1 Do not cut any portion of a pipeline that is under pressure.
- 8.2 Plan the job to shut off or minimize the escape of gas.
- 8.3 Sequence the steps to limit the time and amount of gas to which personnel are exposed.
- 8.4 Follow the procedures contained in **WIGE 2.1** Hazardous Environment when applicable.
- 8.5 When isolating pipeline segments, consider the following during the planning phase:
- 8.5.1 Is the pipeline segment within a system monitored by Gas Control? If so, involve Gas Control in the planning.
 - 8.5.2 Should Gas Tech Engineering be requested to perform a system model to ensure isolating the pipeline segment will not result in an unintentional loss of service to customers?
 - 8.5.3 Is unattended, isolating equipment protected to prevent unauthorized operation?
 - 8.5.4 Are valves blanked or locked? Attach lock-out tags, (Stock Code 16 01 410), to valves.
 - 8.5.5 Are valves, that cannot be blanked or locked, tagged to advise personnel not to operate the valve?

- 8.6 Monitor pressures at the work site to alert gas field personnel of an unintentional increase or decrease in pressure as follows.
- 8.6.1 When the pipeline segment is monitored remotely:
1. Contact Gas Control at the start of the project to discuss monitoring parameters and at what values Gas Control should alert field operations of potential problem(s).
 2. Once the project is completed and system is returned to normal, Gas Supervisor, Gas Engineer, or Gas Tech Service Supervisor should contact Gas Control to verify monitoring parameters are all functioning properly.
- 8.6.2 Pressure monitoring procedures shall be established with safe pressure limits.
- 8.6.3 Personnel assigned to operate isolation equipment shall monitor pressures, both upstream and downstream, by the use of gauges or vents.
- 8.6.4 Personnel monitoring at remote locations shall have communication with the work site and the person in charge of the operation.

End of Instructions.

Operator Qualification (OQ) Required?

YES.

0801: Welding.

1131: Stopper (Stopp) Pipe.

1141: Squeeze Off Plastic Pipe.

1151: Squeeze Off Steel Pipe.

1371 Operate Gas Pipeline – System Control Center Operations

Appendices

NONE.

Attachments

NONE.

Compliance Requirements

49 CFR §192.751 Prevention of accidental ignition.

29 CFR §1926.651(g)(1)(i) Specific excavation requirements.

Reference Documents

[EMER 2.3 Emergency Plan: Emergency Responder.](#)

[EXCV 2.9 Excavation Safety: Working in Hazardous Environment.](#)

[LEAK 2.5 Leak Management: Leak Survey Equipment](#)

[PURG 2 Purging: Methods.](#)

[WIGE 2.1 Working in Gaseous Environment: Hazardous Environment.](#)

Document Rescission

UNCONTROLLED IF PRINTED

ACIG 2 Accidental Ignition: Work Area Protection, October 1, 2022.

Revision Notes

Location of Changes	Summary of Changes
Subsection 7.1- Working with Plastic Pipe	New: Ground the squeeze-off tool prior to squeezing PE pipe.
Subsection 7.2	Revised – Refer to POLY 2.2 Subsection 5.1 Prior To Starting Squeeze-off for additional steps for eliminating external static charge on 1-1/4 inches PE pipe and larger. Removed all of the methods for eliminating static charge since they are listed in POLY 2.2.
Subsection 7.3 NOTE	Removed the note that soapy rags are not required on above-ground squeezers.

APPR-Apprentice Training

APPRENTICE TRAINING

October 1, 2022

APPR 0 Table of Contents

APPR 1 Requirements

- Section 1.0 Objective
- Section 2.0 Scope
- Section 3.0 Target Audience
- Section 4.0 Gas Apprentice Training Overview

APPR 2.1 Gas Journeyman

- Section 1.0 Purpose
 - Section 2.0 Scope
 - Section 3.0 Target Audience
 - Section 4.0 General
 - Section 5.0 Gas Journeyman Training Curriculum
 - Section 6.0 Home Study Course
 - Section 7.0 Examination & Failures
- Appendices:
- Appendix A - Recommended OJT Summary
 - Appendix B - (OJT) Breakdown by Type of Work with Associated B31Q Covered Task
 - Appendix C - Gas Apprentice Performance Appraisal
 - Appendix D - Gas Apprentice Session Evaluation
 - Appendix E - Operator Qualification

APPR 2.2 Corrosion Control

- Section 1.0 Purpose
- Section 2.0 Scope
- Section 3.0 Target Audience
- Section 4.0 Corrosion Technician
- Section 5.0 Senior Corrosion Control Technician
- Section 6.0 Additional Training

UNCONTROLLED IF PRINTED

Section 7.0 Home Study

Appendices

Appendix A - Home Study CBT's

Appendix B - Corrosion Control Technicians Qualifications

APPR 2.3 Gas Storage

Section 1.0 Purpose

Section 2.0 Scope

Section 3.0 Target Audience

Section 4.0 First Step

Section 5.0 Second Step

Section 6.0 Third Step

Section 7.0 Additional Training (Required)

Section 8.0 Additional Training (Optional)

Appendices

Appendix A - AMSE B31Q Operator Qualifications Performed at the end of First Step

Appendix B - AMSE B31Q Operator Qualifications Performed at the end of Second Step

Appendix C - AMSE B31Q Operator Qualifications Performed at the end of Third Step

APPR 2.4 Gas Technical Services

Section 1.0 Purpose

Section 2.0 Scope

Section 3.0 Target Audience

Section 4.0 First Step

Section 5.0 Second Step

Section 6.0 Third Step

Appendices

Appendix A - AMSE B31Q Operator Qualifications Performed at the end of First Step

Appendix B - AMSE B31Q Operator Qualifications Performed at the end of Second Step

Appendix C - AMSE B31Q Operator Qualifications Performed at the end of Third Step

APPR 2.5 Emergency Responder Program

Section 1.0 Purpose

Section 2.0 Scope

Section 3.0 Target Audience

Section 4.0 Curriculum

APPR 2.6 Gas Meter Program

Section 1.0 Purpose

Section 2.0 Scope

Section 3.0 Target Audience

Section 4.0 Gas Meter Reader Program Curriculum

Section 5.0 Gas Meter Specialist Program Curriculum

Appendices

Appendix A - Qualifications

Appendix B - OJT Summary

Appendix C - (OJT) Breakdown by Type of Work Associated B31Q Covered Tasks

APPR 2.7 Hiring Gas Field Personnel

Section 1.0 Purpose

Section 2.0 Scope

Section 3.0 Target Audience

Section 4.0 General

Section 5.0 Evaluation Tools

Section 6.0 Hiring Process

End Table of Contents.

Document Rescission

APPR 0 Apprentice Training: Requirements, January 1, 2016

Revision Notes

Location of Changes	Summary of Changes
Entire document	Format of document has been changed to match the format of October 2022 Issue

1.0 Purpose

This document outlines the formal training programs for new gas field personnel. The programs provide co-workers with the knowledge, skills and abilities needed for proper construction, operation, maintenance and inspection of the Ameren Illinois's gas facilities. This is accomplished using a blended training approach of CBT's, Classroom Instruction, Hands On, and Safe Start Principles.

2.0 Scope

This document address the following:

[Section 3.0 – Target Audience](#)

[Section 4.0 – Gas Apprentice Training Overview](#)

3.0 Target Audience

- Gas Training Personnel
- Gas Operator Qualification Personnel
- Gas Engineers
- Gas Superintendents
- Gas Supervisors
- Gas Field Personnel
- Gas Corrosion Technicians
- Gas Storage Apprentices
- Gas Tech Services

4.0 Gas Apprentice Training Overview

Gas apprentice training programs include the following:

4.1 B31Q- based apprenticeship training by covered task

4.2 Ability Development Program (On the Job Training - OJT)

4.2.1 The ability development program outlines the specific tasks or activities the apprentice should be assigned to between each training session. These assignments ensure that adequate exposure has been given to the apprentice to develop the necessary skills to perform the tasks or activities.

4.3 Gas Apprentice Performance Appraisal

4.3.1 Apprentice Performance Appraisals are to be completed every three months after the apprentice begins the program through the completion of the program.

4.4 Computer Based Training

4.5 Home Study Program

4.6 Examination Testing and Failures

4.7 SafeStart Advanced Safety Awareness Training

End of Instructions

Operator Qualification (OQ) Required?

NO

Appendices

NONE

Attachments

NONE

Compliance Requirements

49 CFR §192.805 Qualification of Pipeline Personnel: Qualification Program

Reference Documents

NONE

Document Rescission

APPR 1 Apprentice Training: Requirements, January 1, 2011

Revision Notes

Location of Changes	Summary of Changes
Entire document	Format of document has been changed to match the format of October 2022 Issue

APPRENTICE TRAINING

October 1, 2022

APPR 2.1 Gas Journeyman

1.0 Purpose

This document provides the requirements for training, OTJ training, and examinations for Ameren Illinois' Gas Journeyman Apprenticeship program in accordance with 49 CFR 192.805.

2.0 Scope

This document addresses the following:

[Section 3.0 – Target Audience](#)

[Section 4.0 – General](#)

[Section 5.0 – Gas Journeyman Training Curriculum](#)

[Section 6.0 – Home Study Course](#)

[Section 7.0 – Examination & Failures](#)

Appendices:

[Appendix A – Recommended OJT Summary](#)

[Appendix B – \(OJT\) Breakdown by Type of Work with Associated B31Q Covered Task](#)

[Appendix C – Gas Apprentice Performance Appraisal](#)

[Appendix D – Gas Apprentice Session Evaluation](#)

[Appendix E – Operator Qualification](#)

3.0 Target Audience

- Gas Training Personnel
- Gas Operator Qualifications Personnel
- Gas Engineers
- Gas Superintendents
- Gas Supervisors
- Gas Apprentices

4.0 General

UNCONTROLLED IF PRINTED

- 4.1 Throughout the Gas Journeyman Apprenticeship, the apprentice will be assigned to Gas Service Work and Gas Construction Work to ensure exposure to specific Covered Tasks.
 - 4.1.1 This will correspond to the training session they are currently preparing to attend.
- 4.2 Once the applicable training is successfully completed, an initial qualification evaluation will be conducted.
- 4.3 At the end of the apprentice program the apprentice will come to the Training Center to take an Apprentice Final exam and be OQ qualified as a Gas Journeyman.

5.0 Gas Journeyman Training Curriculum

- 5.1 Apprentice Orientation & Safety Basics (Held approx. 1 month prior to formal Apprenticeship Program)
 - 5.1.1 Introduction to Training Center Staff and Apprentice Program
 - 5.1.2 Professionalism / Expectations / OJT
 - 5.1.3 Drug and Alcohol Compliance
 - 5.1.4 Insight Learning Management System
 - 5.1.5 Measure and Order Level 1 PPE suits
 - 5.1.6 Distribution of CF33s and Introduction to Operating and Maintenance Plan and Field Safety Manual.
 - 5.1.7. Basic Gas Safety
 - 5.1.8 Basic Excavation Safety
 - 5.1.9 Understanding Job Briefings
 - 5.1.10 Rubber Glove Testing Procedures for Subsurface Electrical Hazards
- 5.2 Gas Basics (Session # 1000)
 - 5.2.1 Operator Qualification / Abnormal Operating Conditions / Direct Observation
 - 5.2.2 Personal Protective Equipment
 - 5.2.3 Firefighting and Proper Fire Fighting Techniques
 - 5.2.4 Characteristics and Hazards of Natural Gas
 - 5.2.5 Recognizing and Reporting Gas Emergencies
 - 5.2.6 Meter Set Inspection and Painting
 - 5.2.7 Includes Initial Qualification on Covered Task # 0991 – Coating Application and Repair – Brushed or Rolled, 0141 – Visual Inspection for Atmospheric Corrosion, 1011 – External Coating Application and Repair - Wrapped and 1201 - Temporary Isolation of Service Lines and Service Discontinuance. Refer to [OQAL 2.1](#) for Cover Task description.
- 5.3 PE Joining (Session #1100)
 - 5.3.1 Installation of PE Pipe
 - 5.3.2 Electrofusion
 - 5.3.3 Butt Fusion
 - 5.3.4 Mechanical Joints

5.3.5 Squeezing Plastic, Static and Grounding

5.3.6 Pressure Testing ≤ 100 PSIG (plastic facilities)

5.3.7 Service Transaction Documentation

5.3.8 Includes Initial Qualification on Covered Task # 0681, 0691, 0701, 0751, 0761, 0781 - Plastic Fusion and Joining. Refer to [QQAL 2.1](#) for Cover Task description

5.4 Job Site Protection (Session #1200)

5.4.1 Conducting Effective Tailboard Meetings / Job Briefing

5.4.2 Excavation Safety

5.4.3 ATSSA Flagging Certification / Certification

5.4.4 Soil Classification, Soils Checklist and Competent Person Training

5.4.5 Job Site Protection

5.4.6 Public Safety Advisor Training

5.5 Working In Gaseous Atmosphere (Session #1300)

5.5.1 Respirator Safety

5.5.2 O&M Procedures

5.5.3 Blowing Gas Protocols

5.5.4 Supplied Air Operation and Calibration

5.5.5 Level 1 and Level 2 Requirements

5.6 Critical Thinking & Problem Solving

5.6.1 Observations

5.6.2 Performing and Analysis

5.6.3 Assessment & Action

5.6.4 Risk – Safety – Impact

5.7 Maps, Symbols & Documentation

5.7.1 Business Process

5.7.2 Working With Maps / Symbology

5.7.3 Map Mark Ups

5.7.4 EPOCH Overview

5.8 Pipefitting (Session # 2300)

5.8.1 Preventing Injuries When Wrenching

5.8.2 Calculating Offsets, Finding Set, Travel and Run

5.8.3 Flanges

5.8.4 TracPipe

5.8.5 Hand Threading, Power Threading

5.8.6 Wrenches, Joints and Threads

5.8.7 System Upgrading

UNCONTROLLED IF PRINTED

5.9 Equipment Operation (Session # 2400)

5.9.1 Backhoe Operational Safety

5.9.2 Trencher Operational Safety

5.9.3 Boring Safety

5.9.4 Hand Signals

5.9.5 Equipment Operation

5.9.6 Sewer Listening Device / Preventing Sewer Cross-Bore

5.9.7 Subsurface Electrical Hazards

5.10 Direct Operated Regulators and Reliefs, Customer Meters (Session # 1500)

5.10.1 Locating, Installing and Protecting Customer Meters & Regulators

5.10.2 Customer Pressure Regulating and Limiting and Relief Devices

5.10.3 Operations and Maintenance of Regulators and Relief

5.10.4 Direct Operated Regulators and Reliefs

5.10.5 Meter Reading

5.10.6 Meter Selection and Sizing

5.10.7 Odor Intensity Training

5.10.8 Gas Meter Data Sheets

5.11 Leak Investigation (Session # 3100)

5.11.1 Gas Detection Instruments

5.11.2 Leak Surveying and Patrols

5.11.3 Gas Leaks and Migration

5.11.4 Leak Investigation

5.11.5 Leak Classification and Documentation

5.11.6 DIMP

5.12 Customer Premise (Session # 3200)

5.12.1 Combustion and Ventilation Air

5.12.2 Venting

5.12.3 Pilots

5.12.4 Control Valves / Safety checks

5.12.5 Gas-Air Adjustments

5.12.6 Lighting Appliances

5.12.7 Code Violations and Hazardous Conditions

5.12.8 Leak Investigations on Customer Equipment

5.12.9 Carbon Monoxide

5.13 Construction, Maintenance and Repair (Session #2000)

UNCONTROLLED IF PRINTED

- 5.13.1 Installation of Steel & Plastic Pipe
- 5.13.2 Repair of Imperfections and Damage
- 5.13.3 Squeezing Steel & Plastic
- 5.13.4 Leak Clamps and Sleeves
- 5.13.5 Casings, Vents, and Seals
- 5.13.6 Pressure Testing \geq 100 PSIG (steel facilities)
- 5.13.7 Facility Retirement and Abandonment
- 5.13.8 Bonding and Grounding
- 5.13.9 Farm Tap Design
- 5.13.10 Documentation
- 5.14 Cathodic Protection (Session #2100)
 - 5.14.1 Cathodic Protection System – Maintenance
 - 5.14.2 Atmospheric Corrosion
 - 5.14.3 Measuring Corrosion
 - 5.14.4 Pipe Coating Inspection, Installation, and Maintenance
 - 5.14.5 Pipe to Soil Testing
 - 5.14.6 Exothermic Welding
 - 5.14.7 Buried Pipe Exam Documentation
- 5.15 Valve Inspection and Maintenance (Session #1400)
 - 5.15.1 O&M Procedures
 - 5.15.2 Valve Types
 - 5.15.3 Flushing and Lubricating
 - 5.15.4 Valve Inspection Documentation
- 5.16 Tapping & Stopping (Session 3000)
 - 5.16.1 Tapping – Valve Tee
 - 5.16.2 Tapping and Stopping – $\frac{3}{4}$ " Low Pressure Fitting
 - 5.16.3 Tapping and Stopping - 2" Low Pressure Fitting
 - 5.16.4 Tapping and Stopping - 4" Low Pressure Fitting
 - 5.16.5 Stop Off With A One Way Feed
 - 5.16.6 Stop Off With A Two Way Feed
 - 5.16.7 Tap PE Side Wall Fitting
 - 5.16.8 Mueller Autoperf Tee
- 5.17 Damage Prevention / Location (Session #3300)
 - 5.17.1 JULIE Law, Damage Prevention
 - 5.17.2 Pipeline Patrols and Markers

5.17.3 Claims and Documentation for damaged facilities

5.17.4 Locating Theory and Principles

5.17.5 Conductive Locating

5.17.6 Inductive Locating (One Man and Two Man)

5.17.7 Inductive Clamp Locating

5.17.8 Depth Calculation Using Triangulation

5.18 Pilot Operated Regulators and Pilot Operated Reliefs (Session # 2200)

5.18.1 Operation of Pilot Operated Regulators and Reliefs

5.18.2 Testing, Preventative and Corrective Maintenance of Commercial Meter Sets

5.18.3 Tube Bending

5.18.4 Introduction to Gas Control

5.18.5 Overview of Odorizer Operation, SCADA System, Gas Storage Field Operation

6.0 Home Study Course

6.1 All apprentices will complete the Home Study Course. This course is intended to give the apprentice an overview of all Company Standards, policies and procedures.

6.2 The apprentices are assigned a specific Home Study Exercises and Reading Assignments which are to be completed between their training sessions and prior to the beginning of their next training session.

6.2.1 This work is to be done on the apprentice's own time.

6.2.2 Activity sheets covering the information in the Home Study/Home Reading Assignments will be turned in upon completion in class.

6.3 The apprentice is required to successfully complete the Home Study Course with a passing grade of 80% on all exercises, exams and activities.

6.4 The Home Study Program encompasses the content of the:

6.4.1 Gas Operating and Maintenance Plan

6.4.2 Utility Work Zone Traffic Control Field Manual

6.4.3 Manufacturers' Instructions and Handouts

6.4.4 Other Company Documents

7.0 Examinations & Failures

7.1 Examinations

7.1.1 Each Region Gas Superintendent and Gas Supervisor will receive a report of the apprentice's scores at the completion of each Training Cell.

1. All apprentices must achieve a minimum score of an 80% on all training cell module exams, training cell session exams and home study exams.

2. If an apprentice scores less than 80% on any of these exams please refer to "1st Failure".

7.2 1st Failure

7.2.1 The apprentice will meet with a Gas Training Supervisor and review all items missed on the exam.

7.2.2 The Region Gas Superintendent and Gas Supervisor will be notified of the failure(s).

7.2.3 The apprentice will be retested on the exam(s) before the beginning of the next scheduled Training Cell.

7.2.4 If the apprentice scores higher than 80% they will continue in the program. If the apprentice fails the exam for a 2nd time please refer to "2nd Failure".

7.3 2nd Failure

7.3.1 If the apprentice fails an exam for the second time the apprentice will be suspended from the program until a meeting can be held with the apprentice, Training Supervisor, Superintendent of Training & Qualification and the Region Gas Superintendent and/or Gas Supervisor. At this time a course of action will be determined.

7.4 3rd Failure

7.4.1 Any apprentice who fails any examination for the third time will be automatically removed from the program.

End of Instructions

Operator Qualification (OQ) Required?

YES – Refer to [Appendix E](#)

Appendices

[Appendix A – Recommended OJT Summary](#)

[Appendix B – \(OJT\) Breakdown by Type of Work with Associated B31Q Covered Task](#)

[Appendix C – Gas Apprentice Performance Appraisal](#)

[Appendix D – Gas Apprentice Session Evaluation](#)

[Appendix E – Operator Qualification](#)

Attachments

NONE

Compliance Requirements

49 CFR §192.805 Qualification of Pipeline Personnel: Qualification Program

49 CFR §192.809 Qualification of Pipeline Personnel: General

Reference Documents

NONE

Document Rescission

UNCONTROLLED IF PRINTED

APPR 2.01 Apprentice Training: Gas Journeyman, May 15, 2022

Revision Notes

Location of Changes	Summary of Changes
Entire document	Format of document has been changed to match the format of October 2022 Issue

Appendix A, Recommended OJT Summary

A-1. The Gas Apprentice should be exposed to each category of tasks during each 9 month progression of the program to the extent possible. Total hours / jobs worked as shown in the table below are cumulative over the duration of the apprenticeship and should be achieved prior to completion of the program.

Type Of Work (Hours Worked)	Total Hours
Cathodic Protection	72 HOURS
PE Installation	280 HOURS
Steel Installation	44 HOURS
Repairs	74 HOURS
Maintenance	80 HOURS
Pressure Control	80 HOURS
Tapping	32 HOURS
Damage Prevention	24 HOURS
Odorization	16 HOURS
Pipeline Patrol	72 HOURS
Equipment Operation	264 HOURS

UNCONTROLLED IF PRINTED

Type of Work (# Jobs)	Total Jobs Worked
Inside Leak Investigation	30 EA
Outside Leak Investigation	30 EA
Customer Meter Installations/Exchanges - Small (Meter Size 630 CFH and under)	40 EA
Customer Meter Installations/Exchanges - Large (Meter Size 800 CFH and above)	10 EA
Appliance Relights/Turn-ons	60 EA
Locating	30 EA

Appendix B, (OJT) Breakdown by Type of Work with Associated B31Q Covered Task

Type Of Work	B31Q Covered Task and Description
Cathodic Protection	0001, CP Readings 0041, Installing and Maintaining Electrical Connections 0051, Cadwelding 0081, Installing CP Isolation Devices 0201, Inspect Pipe for Damage 0211, Measure/Characterize Pipe Damage 0991, Coating Application and Repair Brushed and Rolled 0141, Visual Inspection for Atmospheric Corrosion 0151, Visual Inspection of Buried Pipe Components When Exposed 0161, Visual Inspection for Internal Corrosion 0171, Measure External Corrosion 0181, Measure Internal Corrosion 0191, Measure Atmospheric Corrosion 1011, External Coating Application and Repair-Wrapped 1421, Examination Techniques (Visual Coating Exam and Jeeping)

UNCONTROLLED IF PRINTED

<p>PE Installation</p>	<p>0561, Pressure Test < 100 psig 0571, Pressure Test ≥ 100 psig 0591, Leak Test at Operating Pressure 0641, Inspection of Pipe for Damage Prior to Installation 0681, Joining with Stab Fittings 0691, Joining Non-Bottom Out Compression Fittings 0701, Joining Bottom Out Compression Coupling 0751, Joining PE Butt Heat Fusion Manual 0761, Joining PE Butt Heat Fusion Hydraulic 0781, Joining PE Pipe Electrofusion 0901, Install PE Pipe in Ditch 0911, Install PE Pipe in Bore 0921, Install PE Pipe Plow/Pull 0931, Install PE Pipe Plow/Plant 0941, Install Tracer Wire 0981, Backfilling 1141, Squeeze Off PE Pipe</p>
<p>Steel Installation</p>	<p>0561, Pressure Test < 100 psig 0571, Pressure Test ≥ 100 psig 0591, Leak Test at Operating Pressure 0641, Visual Inspect Pipe and Components Prior to Installation 0721, Joining of Pipe, Threaded Joints 0731, Joining of Pipe, Flange Assembly 0861, Installation of Steel Pipe in a Ditch 0871, Installation of Steel Pipe in a Bore 0881, Installation of Steel Pipe Plowing/Pull-In 0891, Field Bending of Steel Pipe 0971, Installation of Casing Spacers, Vents and Seals</p>
<p>Repairs</p>	<p>1041, Install Mechanical Clamps and Sleeves-Bolted 1151, Squeeze Off Steel Pipe</p>
<p>Maintenance</p>	<p>1191, Maintenance of Service Valves Upstream of Customer Meter 0301, Manually Opening and Closing Valves 0321, Valve Corrective Maintenance</p>

UNCONTROLLED IF PRINTED

	<p>0331, Valve Visual Inspection and Partial Operation</p> <p>0961, Above Ground Supports and Anchors - Inspection, Preventive and Corrective Maintenance</p>
Pressure Control	<p>0381, Spring Loaded Pressure Regulating Devices - Inspection and Testing, Preventive and Corrective Maintenance</p> <p>0391, Pilot - Operated Pressure Regulating Device - Inspection and Testing, Preventive and Corrective Maintenance</p> <p>1161, Installation of Customer Meters and Regulators - Residential and Small Commercial</p> <p>0311, Adjust and Monitor Flow or Pressure - Manual Valve Operation</p> <p>1171, Installing and Maintaining Customer Pressure Regulating, Limiting and Relief Device - Large Commercial and Industrial</p>
Tapping	<p>1101, Tapping a Pipeline with a Built In cutter</p> <p>1081, Tapping a Pipeline (Tap Diameter 2" and less)</p> <p>1091, Tapping a Pipeline (Tap Diameter Greater than 2")</p> <p>1131, Stopper (Stopp) Pipe</p>
Damage Prevention	<p>1291, Damage Prevention Inspection During Third Party Excavation or Encroachment Activities as Determined Necessary by the Operator Locate Underground Pipelines</p> <p>1341, Provide and Assure Adequate Pipeline Support During Operator Initiated Excavation Activities</p>
Odorization	<p>1211, Odorization - Periodic Sampling</p>
Pipeline Patrol	<p>1301, Install and Maintain Pipeline Markers</p> <p>1311, Inspect Pipeline Surface Conditions - Patrol Right of Way or Easement</p> <p>1351, Vault Inspection and Maintenance</p>
Equipment Operation	<p>0981, Backfill</p>
Inside Leak Investigation	<p>1231, Inside Leak Investigation</p> <p>A003, Emergency Plan</p>
Outside Leak Investigation	<p>1241, Outside Leak Investigation</p> <p>1261, Walking Gas Leak Survey</p> <p>A003, Emergency Plan</p>

UNCONTROLLED IF PRINTED

Customer Meter Installations/Exchanges - Small	1161, Installation of Customer Meters and Regulators, Residential and Small Commercial
Customer Meter Installations/Exchanges - Large	1171, Installing Customer Meters - Large Commercial and Industrial
Appliance Re-lights / Turn-ons	1201, Temporary Isolation of Service Lines and Service Discontinuance A001, Relighting Customer Appliances
Locating	1291, Locate Underground Pipelines

Appendix C, Gas Apprentice Performance Appraisal

C-1. The gas apprentice performance appraisal form does not take the place of the evaluation form(s) required by each union. Please check the contract in your area to ensure the proper forms are being completed.

Apprentice Name _____

Date _____



Date _____

Job Knowledge: Has adequate knowledge of job, is aware of what is expected of them.

Substandard									Acceptable									Excels	
1 <input type="checkbox"/>	2 <input type="checkbox"/>	3 <input type="checkbox"/>	4 <input type="checkbox"/>	5 <input type="checkbox"/>	6 <input type="checkbox"/>	7 <input type="checkbox"/>	8 <input type="checkbox"/>	9 <input type="checkbox"/>	10 <input type="checkbox"/>	11 <input type="checkbox"/>	12 <input type="checkbox"/>	13 <input type="checkbox"/>	14 <input type="checkbox"/>	15 <input type="checkbox"/>	16 <input type="checkbox"/>	17 <input type="checkbox"/>	18 <input type="checkbox"/>	19 <input type="checkbox"/>	20 <input type="checkbox"/>

Comments: _____

Comprehensive Instructions: Learning ability. Understands and retains instruction. Able to accomplish repetitive tasks without continuous instruction.

Substandard									Acceptable									Excels	
1 <input type="checkbox"/>	2 <input type="checkbox"/>	3 <input type="checkbox"/>	4 <input type="checkbox"/>	5 <input type="checkbox"/>	6 <input type="checkbox"/>	7 <input type="checkbox"/>	8 <input type="checkbox"/>	9 <input type="checkbox"/>	10 <input type="checkbox"/>	11 <input type="checkbox"/>	12 <input type="checkbox"/>	13 <input type="checkbox"/>	14 <input type="checkbox"/>	15 <input type="checkbox"/>	16 <input type="checkbox"/>	17 <input type="checkbox"/>	18 <input type="checkbox"/>	19 <input type="checkbox"/>	20 <input type="checkbox"/>

Comments: _____

Comprehends Gas Standards and Prints: Understands and properly implements Gas Standards and engineering prints.

UNCONTROLLED IF PRINTED

Substandard

Acceptable

Excels

1 2 3 4 5 6 7 8 9 10

Comments: _____

Safety: Comprehends and has adequate knowledge of hazards involved and takes proper precautions. Is safety conscious for themselves and crew members.

Substandard

Acceptable

Excels

1 2 3 4 5 6 7 8 9 10

Comments: _____

Initiative: Self-starter. Willing to perform previously instructed tasks without being told. Asks questions when appropriate and volunteers.

Substandard

Acceptable

Excels

1 2 3 4 5 6 7 8 9 10

Comments: _____

Judgment: Considers all factors before acting. Uses common sense.

Substandard

Acceptable

Excels

1 2 3 4 5 6 7 8 9 10

Comments: _____

Cooperation: Accepts constructive criticism. Works well with fellow field personal.

Substandard

Acceptable

Excels

1 2 3 4 5 6 7 8 9 10

Comments: _____

Customer Premise Work: Has the ability to work on customer-owned facilities and properly communicates with the customer in a respectful manner.

Substandard

Acceptable

Excels

1 2 3 4 5 6 7 8 9 10

Comments: _____

Construction Work: Has the ability to work beneficially on a crew. Communicates effectively with other crew members.

Substandard

Acceptable

Excels

1 2 3 4 5 6 7 8 9 10

Comments: _____

Use of tools, Instruments: Demonstrates skill and ability in using proper tool for assigned task. Has good coordination.

Substandard	Acceptable					Excels				
1 <input type="checkbox"/>	2 <input type="checkbox"/>	3 <input type="checkbox"/>	4 <input type="checkbox"/>	5 <input type="checkbox"/>	6 <input type="checkbox"/>	7 <input type="checkbox"/>	8 <input type="checkbox"/>	9 <input type="checkbox"/>	10 <input type="checkbox"/>	

Comments: _____

Use of Excavating Equipment: Demonstrates skill and ability in using excavating equipment. Clearly understands safety concerns with power equipment.

Substandard	Acceptable					Excels				
1 <input type="checkbox"/>	2 <input type="checkbox"/>	3 <input type="checkbox"/>	4 <input type="checkbox"/>	5 <input type="checkbox"/>	6 <input type="checkbox"/>	7 <input type="checkbox"/>	8 <input type="checkbox"/>	9 <input type="checkbox"/>	10 <input type="checkbox"/>	

Comments: _____

Interest and Attitude: Interested in the work. Seems anxious to learn. Alert to new ideas. Interested in doing a good job.

Substandard	Acceptable					Excels				
1 <input type="checkbox"/>	2 <input type="checkbox"/>	3 <input type="checkbox"/>	4 <input type="checkbox"/>	5 <input type="checkbox"/>	6 <input type="checkbox"/>	7 <input type="checkbox"/>	8 <input type="checkbox"/>	9 <input type="checkbox"/>	10 <input type="checkbox"/>	

Comments: _____

Has Apprentice shown overall satisfactory progress? Yes No

Please provide detailed comments on Apprentice's performance based on personal observation:

(Comments required if overall progress is not satisfactory)

Comments: _____

Reviewed with:

By _____

Apprentice Name

Supervisor

By _____

Date

Field Personnel

By _____

Field Personnel

Page

- C-2. The conscientious completion of this form by all parties and counseling with the apprentice is very important.
- C-3. In order for mutual benefit to be obtained by its use, it should be discussed in its entirety with the apprentice each month. This performance appraisal must be submitted to the Gas Training Center staff as well as the union.

Appendix D, Gas Apprentice Session Evaluation

- D-1. The Gas apprentice session evaluation form is used to:
 - D-1.1 Notify the gas supervisor of what areas of training have been completed
 - D-1.2 Communicate what type On the Job Training (OJT) exposure is needed.
 - D-1.3 Communicate observations of apprentice's behavior and performance while in training.



GAS APPRENTICE SESSION EVALUATION

Employee Name	
Employee Number	
Location	
Division	
Supervisor	

Apprentice current with OJT sheets?

Yes No

Period Covered by this Report FROM: Click here to enter a date. TO:

Session: Gas Basics: Focus of Session: Hazards of Natural Gas, Ignition Sources, Emergency Conditions, Meter Header Inspection & Atmospheric Corrosion

Session: PE Mains & Services

Focus of Session: PE Fusion (Electrofusion & Butt Fusion), Mechanical Fittings

Gas Basics	
Home Reading Activity	<input type="checkbox"/> Complete <input type="checkbox"/> Incomplete
OQ Exam - Gas Apprentice Emergency Responder	<input type="checkbox"/> Pass <input type="checkbox"/> Fail Score _____
OQ Exam -Meter Set Inspections & Corrosion Exam	<input type="checkbox"/> Pass <input type="checkbox"/> Fail Score _____
Plastic Fusion	
Home Reading Activity	<input type="checkbox"/> Complete <input type="checkbox"/> Incomplete
OQ Exam – Plastic Fusion	<input type="checkbox"/> Pass <input type="checkbox"/> Fail Score _____

Initiative – Apprentice was on time and eager to learn. Apprentice was engaged and alert during class. Required reading and home assignments were completed.		
Substandard	Acceptable	Excels
1 <input type="checkbox"/>	2 <input type="checkbox"/> 3 <input type="checkbox"/> 4 <input type="checkbox"/> 5 <input type="checkbox"/>	6 <input type="checkbox"/> 7 <input type="checkbox"/> 8 <input type="checkbox"/> 9 <input type="checkbox"/> 10 <input type="checkbox"/>
Comments: _____		
Safety – Apprentice has an awareness of hazards involved and takes proper precautions. Selects proper PPE for task and is safety conscious for themselves and others in class.		
Substandard	Acceptable	Excels
1 <input type="checkbox"/>	2 <input type="checkbox"/> 3 <input type="checkbox"/> 4 <input type="checkbox"/> 5 <input type="checkbox"/>	6 <input type="checkbox"/> 7 <input type="checkbox"/> 8 <input type="checkbox"/> 9 <input type="checkbox"/> 10 <input type="checkbox"/>
Comments: _____		
Use of Tools, Instruments: Demonstrates skill and ability in using proper tool for assigned task.		
Substandard	Acceptable	Excels
1 <input type="checkbox"/>	2 <input type="checkbox"/> 3 <input type="checkbox"/> 4 <input type="checkbox"/> 5 <input type="checkbox"/>	6 <input type="checkbox"/> 7 <input type="checkbox"/> 8 <input type="checkbox"/> 9 <input type="checkbox"/> 10 <input type="checkbox"/>
Comments: _____		

Appendix E, Operator Qualification

E-1. Each Gas Apprentice will be qualified during the Gas Journeyman Apprentice Program as identified in the table below. 30-60 days before becoming a Journeyman, the apprentice should be re-qualified on all Gas Journeyman Covered Tasks to achieve one qualification date going forward.

B31Q Task Number	Covered Task Description	Class Session Number	Initial
0141	Corrosion Monitoring - Atmospheric, External and Corrosion Internal	1000	1000
0201	Visual Inspection of Installed Pipe and Components for Mechanical Damage	1000	1000
0991	Coating Application and Repair – Brushed or Rolled	1000	1000
1011	External Coating Application and Repair - Wrapped	1000	1000
1201	Temporarily Disconnect Customer Services	1000	1000
0681	Joining – Stab Fittings PE Pipe	1100	1100
0691	Joining of Pipe-Non Bottom Out Compression Coupling	1100	1100
0701	Joining of Pipe-Bottom Out Compression Coupling	1100	1100
0711	Joining of Pipe - Compression Coupling	1100	1100
0751	Joining of PE Pipe – Butt Heat Fusion	1100	1100
0761	Joining of PE Pipe Butt Heat Fusion Hydraulic	1100	1100
0781	Joining of PE Pipe - Electrofusion	1100	1100
1101	Tapping a Pipeline With Built In Cutter	1100	1100
0561	Pressure Test – Non-liquid Medium < 100 psig	1100	Mi
0591	Leak Test at Operating Pressure	1100	Mi
0641	Visually Inspect Pipe and Components Prior to Installation	1100	Mi
0901	Install PE Pipe in Ditch	1100	Mi

UNCONTROLLED IF PRINTED

0911	Install PE Pipe in Bore	1100	Mi
0921	Install PE Pipe Plow/Pull	1100	Mi
0931	Install PE Pipe Plow/Plant	1100	Mi
0941	Install Tracer Wire	1100	Mi
0981	Backfilling	1100	Mi
1141	Squeeze Off PE Pipe	1100	Mi
0381	Spring Loaded Pressure Regulating Device	1500	Mi
0411	Spring Loaded Pressure Limiting and Relief Device	1500	Mi
1161	Install Meters and Regulators-Residential Small Commercial	1500	Mi
0571	Pressure Test – Non-Liquid Medium \geq 100 Psig	2000	Mi
0861	Installation of Steel Pipe In a Ditch	2000	Mi
0871	Installation of Steel Pipe In Bore	2000	Mi
0881	Installation of Steel Pipe Plowing/Pull In	2000	Mi
0891	Field Bending Steel Pipe	2000	Mi
0951	Installation of Pipe Above Ground	2000	Mi
0961	Above Ground Supports and Anchors - Inspection, Preventive/Corrective Maintenance	2000	Mi
0971	Installation/Maintenance Casing Spacers Vents Seals	2000	Mi
1041	Install Mechanical Clamps Sleeves Bolted	2000	Mi
1151	Squeeze Off Steel Pipe	2000	Mi
A002	Abandonment	2000	Mi
0001	Measure Structure-to-Electrolyte Potential	2100	Mi
0041	Installation and Maintenance of Mechanical Connections	2100	Mi
0051	Installation of Exothermic Electrical Connections	2100	Mi

UNCONTROLLED IF PRINTED

0081	Install Cathodic Protection Electrical Isolation Devices	2100	Mi
0151	Visual Inspection of Buried Pipe and Components When Exposed	2100	Mi
0161	Visual Inspection for Internal Corrosion	2100	Mi
0171	Measure External Corrosion	2100	Mi
0181	Measure Internal Corrosion	2100	Mi
0191	Measure Atmospheric Corrosion	2100	Mi
1421	Direct Examination Techniques	2100	Mi
0721	Joining of Pipe - Threaded Joints	2300	Mi
0731	Joining of Pipe - Flange Assembly	2300	Mi
1321	Damage Prevention During Excavation Activities By or on Behalf of the Operator	2400	Mi
1331	Damage Prevention Inspection During Third Party Excavation or Encroachment Activities as Determined Necessary by Operator	2400	Mi
1341	Provide or Assure Adequate Pipeline Support During Operator Initiated Excavation Activities	2400	Mi
1311	Inspect Pipeline Surface Conditions – Patrol Right of Way or Easement	3100	Mi
1191	Maintenance of Service Valves Upstream of Customer Meter	3200	Mi
A001	Service Reconnect	3200	Mi
1651	Purge – Flammable or Inert Gas	1100 , 2000	Mi
0211	Measure and Characterize Mechanical Damage on Installed Pipe and Components	1100 , 2100	Mi
0301	Manually Opening and Closing Valves	1400	
0311	Adjust and Monitor Flow or Pressure - Manual Valve Operation	1400	
0321	Valve Corrective Maintenance	1400	

UNCONTROLLED IF PRINTED

0331	Valve - Visual Inspection and Partial Operation	1400	
0341	Valve - Preventive Maintenance	1400	
1351	Vault Inspection Maintenance	1400	
0391	Pilot – Operated Pressure Regulating Device – Inspection, Testing, Preventive and Corrective Maintenance	2200	
0421	Pilot – Operated Pressure Limiting Device – Inspection, Testing, Preventive and Corrective Maintenance	2200	
0821	Tubing & Fitting Installation - Instrument, Control and Sampling	2200	
1171	Install Meters Industrial	2200	
1181	Install/Maintain Regulating, Limiting and Relief Device - Large Commercial Industrial	2200	
1081	Tapping Pipeline ≤ 2"	3000	
1091	Tapping Pipeline > 2"	3000	
1131	Stopples Pipe	3000	
1211	Odorization-Periodic Sampling	3100	
1231	Outside Gas Leak Investigation	3100	
1241	Inside Gas Leak Investigation	3100	
1261	Walking Gas Leakage Survey	3100	
1271	Mobile Gas Leak Survey - FI	3100	
A003	Emergency Response	3100	
1291	Locating Underground Pipelines	3300	
1301	Install and Maintain Pipeline Markers	3300	

1.0 Purpose

This section outlines the formal training programs for Corrosion Control for new gas field personnel. This is accomplished using a blended training approach of CBT's, Classroom Instruction, Hands On and Safe Start Principles.

2.0 Scope

This document addresses the following:

[Section 3.0 – Target Audience](#)

[Section 4.0 – Corrosion Technician](#)

[Section 5.0 – Senior Corrosion Control Technician](#)

[Section 6.0 – Additional Training](#)

[Section 7.0 – Home Study Course](#)

Appendices:

[Appendix A – Home Study CBT's](#)

[Appendix B – Corrosion Control Technician Qualifications](#)

3.0 Target Audience

- Gas Training Personnel
- Gas Operator Qualifications Personnel
- Gas Corrosion Control Technicians / Specialists
- Gas Corrosion Control Supervisors

4.0 Corrosion Technician

4.1 1000 - Cathodic Protection Basics

4.1.1 Basic Electricity

4.1.2 Basic Chemistry

4.1.3 Basic Corrosion Theory

4.1.4 Reference Electrodes (Half-Cells)

4.2 1100 – Corrosion

4.2.1 Corrosion Cells

4.2.2 Polarization

4.2.3 Anode/Cathode Ratio

4.2.4 Causes of Corrosion

4.3 1200 – Corrosion Control – CP

4.3.1 Cathodic Protection

4.3.2 Factors Influencing Operation of Cathodic Protection

4.3.3 Criteria for Cathodic Protection

4.4 1300 - Field Measurements

4.4.1 Safety

4.4.2 Field Measurements (annual, isolated, crossings, casings, bonds, wells)

4.4.3 Electrical Isolation

4.4.4 Measuring Electrolyte Resistivity

4.4.5 Measuring pH

4.5 1400 - Equipment

4.5.1 Use of Pipe Locating Devices

4.5.2 Use of Current Interrupters

4.5.3 Coupon Measurements

4.6 1500 - Stray Current

4.6.1 Introduction to Stray Current Interference

4.6.2 Stray Current Corrosion Control

4.7 1600 - Monitoring

4.7.1 Monitoring Cathodic Protection Effectiveness

4.7.2 Recordkeeping

4.8 1700 - CP Systems

4.8.1 Installing CP Components

4.8.2 Galvanic (Sacrificial) Anodes

4.8.3 Impressed Current Ground beds

4.8.4 Connections

4.8.5 Installation of Rectifiers or Other Power Sources

4.9 1800 - Evaluating Corrosion

4.9.1 External Corrosion Above and Below Grade

4.9.2 Internal Corrosion

4.9.3 Pit measurement

4.10 1900 - Troubleshooting

4.10.1 Finding a Short

4.10.2 Testing Casings

4.10.3 Current Requirement Tests

4.10.4 Stray Current Tests

4.10.5 Trouble Shoot and Repair a Rectifier

4.10.6 Conduct Close Interval Surveys and Record Data, Draw Conclusions

4.10.7 Perform Insulator Tests

4.10.8 Read Bonds and Record Data

4.10.9 Measure Current and P/S at Anode Beds

4.11 1950 - Internal Corrosion (Optional)

5.0 Senior Corrosion Control Technician

5.1 2050 – Corrosion Theory

5.1.1 The Corrosion Cell

5.1.2 Electrolyte

5.1.3 Polarization

5.1.4 Passivity

5.1.5 Forms of Corrosion

5.2 2150 – Cathodic Protection Fundamentals

5.2.1 Polarization of a Structure

5.2.2 Current Requirements

5.2.3 Components of Galvanic Cathodic Protection

5.2.4 Components of Impressed Current Cathodic Protection

5.2.5 DC Power Sources for Cathodic Protection

5.2.6 Rectifier Testing

5.3 2250 - Advanced Field Measurements

5.3.1 Pipeline Current Measurements

5.3.2 Surface Coating Evaluation Techniques on Buried Pipelines

5.3.3 Electrical Isolation

5.3.4 Casings

5.4 2350 – DC Stray Current Interference

5.4.1 Static (Steady State) Stray Current

5.4.2 Dynamic Stray Currents

5.4.3 Resolving Interference Problems

5.5 2450 – AC Interference

5.5.1 AC Testing and Mitigation

5.6 2550 - Major Objectives of a Cathodic Protection System

5.6.1 Coating

5.6.2 Monitoring

UNCONTROLLED IF PRINTED

5.6.3 Detailed Field Survey

5.6.4 Records

6.0 Additional Training

6.1 2600 – Purdue Basics

6.2 2650 – Purdue Intermediate

6.3 2700 – Rectifier Repair

6.4 2750 – NACE Cathodic Protection Tester (CPI)

6.5 2800 – Purdue Advanced

6.6 2850 – NACE Cathodic Protection Technician (CPII)

7.0 Home Study Course

7.1 The Corrosion Technician will be assigned specific Computer Based Training Modules that correspond to their upcoming training session. To complete each section, the Corrosion Technician will study the course work and fill out the home study exercise provided for each section and complete the CBT's online. This work is to be done on the Corrosion Technician's own time.

7.2 The Corrosion Technician is required to successfully complete the Home Study Course with a passing grade of 80% on all exercises and exams.

End of Instructions

Operator Qualification (OQ) Required?

YES

See Appendix B – Corrosion Control Technician Qualifications

Appendices

[Appendix A - Home Study CBT's](#)

[Appendix B – Corrosion Control Technician Qualifications](#)

Attachments

NONE

Compliance Requirements

49 CFR §192.805 Qualification of Pipeline Personnel: Qualification Program

49 CFR §192.809 Qualification of Pipeline Personnel: General

Reference Documents

NONE

Document Rescission

APPR 2.02 Apprentice Training: Corrosion Control, January 1, 2011

Revision Notes

UNCONTROLLED IF PRINTED

Location of Changes	Summary of Changes
Entire document	Format of document has been changed to match the format of October 2022 Issue

Appendix A, Home Study CBT's

Home Study CBT	ASME B31Q Number
Measure Structure-to-Electrolyte Potential	0001
Conduct Close Internal Survey	0011
Measure Soil Resistivity	0021
Inspect and Monitor Galvanic Ground Beds/Anodes	0031
Installation and Maintenance of Mechanical Electrical Connections	0041
Installation of Exothermic Electrical Connections	0051
Inspect or Test Cathodic Protection Bonds	0061
Inspect or Test Cathodic Protection Electrical Isolation Devices	0071
Install Cathodic Protection Electrical Isolation Devices	0081
Troubleshoot In-Service Cathodic Protection System	0091
Inspect Rectifier and Obtain Readings	0101
Maintain Rectifier	0111
Visual Inspection for Atmospheric Corrosion When Exposed	0141
Visual Inspection of Buried Pipe and Components	0151
Visual Inspection for Internal Corrosion	0161

UNCONTROLLED IF PRINTED

Measure External Corrosion	0171
Measure Internal Corrosion	0181
Measure Atmospheric Corrosion	0191

Appendix B, Corrosion Control Technician Qualifications

B-1. Qualifications

- 0001: Measure Structure-To-Electrolyte Potential
- 0011: Conduct Close Interval Survey
- 0021: Measure Soil Resistivity
- 0031: Inspect and Monitor Galvanic Ground Beds
- 0041: Installation and Maintenance of Mechanical Connections
- 0051: Installation of Exothermic Electrical Connections
- 0061: Inspect or Test Cathodic Protections Bonds
- 0071: Inspect or Test Cathodic Protection Electrical Isolation Beds
- 0081: Install Cathodic Protection Electrical Isolation Devices
- 0091: Troubleshoot In-Service Cathodic Protection System
- 0101: Inspect Rectifier and Obtain Readings
- 0111: Maintain Rectifier
- 0121: Collect Sample for Internal Corrosion Monitoring
- 0131: Insert and Remove Coupons/Probes for Internal Corrosion Monitoring
- 0141: Visual Inspection for Atmospheric Corrosion
- 0151: Visual Inspection of Buried Pipe and Components When Exposed
- 0161: Visual Inspection for Internal Corrosion
- 0171: Measure External Corrosion
- 0181: Measure Internal Corrosion
- 0191: Measure Atmospheric Corrosion

1.0 Purpose

This section outlines the formal training programs for new gas storage field personnel. This is accomplished using a blended training approach of CBT's, Classroom Instruction, Hands-On and Safe Start Principles.

2.0 Scope

This document addresses the following:

[Section 3.0 – Target Audience](#)

[Section 4.0 – First Step](#)

[Section 5.0 – Second Step](#)

[Section 6.0 – Third Step](#)

[Section 7.0 – Additional Training \(Required\)](#)

[Section 8.0 – Additional Training \(Optional\)](#)

Appendices:

[**Appendix A - ASME B31Q Operator Qualifications Performed at the end of First Step**](#)

[**Appendix B - ASME B31Q Operator Qualifications Performed at the end of Second Step**](#)

[**Appendix C - ASME B31Q Operator Qualifications Performed at the end of Third Step**](#)

3.0 Target Audience

- Gas Training Personnel
- Gas Operator Qualification Personnel
- Gas Storage Field Supervisors
- Gas Storage Field Personnel

4.0 First Step

4.1 Apprentice Orientation (Held 1 month prior to formal Apprenticeship Program)

4.1.1 Introduction to Training Center Staff, Apprentice Program and Policies

- 4.1.2 Professionalism / Expectations/OJT
- 4.1.3 CBT - Password and ID's - How to log into the system
- 4.1.4 Measure and Order Level 1 suits
- 4.1.5 Information for fit testing / medical van (need prior to session 1300)
- 4.1.6 Distribution and Introduction to Operating & Maintenance Plan and Gas Operations Field Reference Guide
- 4.2 Gas Basics (Session #1000)
 - 4.2.1 Abnormal Operating Conditions
 - 4.2.2 Direct Observation
 - 4.2.3 Drug and Alcohol Compliance
 - 4.2.4 Personal Protective Equipment
 - 4.2.5 Firefighting and Proper Fire Fighting Techniques
 - 4.2.6 Characteristics and Hazards of Natural Gas
 - 4.2.7 Recognizing and Reporting Gas Emergencies
 - 4.2.8 Meter Set Inspection and Painting
- 4.3 Job Site Protection (Session #1200)
 - 4.3.1 Conducting Effective Tailboard Meetings
 - 4.3.2 Excavation Safety
 - 4.3.3 ATSSA Flagging Certification / Certification
 - 4.3.4 Competent Person Training
 - 4.3.5 Soil Classification and Competent Person Training
 - 4.3.6 Job Site Protection
 - 4.3.7 Hand Signals
- 4.4 Working In Gaseous Environment (Session #1300)
 - 4.4.1 Respirator Safety
 - 4.4.2 Policies and Procedures
 - 4.4.3 Blowing Gas Protocols
 - 4.4.4 Breather Box Operation and Calibration
 - 4.4.5 Level 1 and Level 2 Requirements
- 4.5 Valve Inspection and Maintenance (Session #1400)
 - 4.5.1 Policies and Procedures
 - 4.5.2 Valve Types
 - 4.5.3 Flushing and Lubricating
- 4.6 Storage Field Geology (Session #4700)
- 4.7 Reading Blueprints (Session #4750)
- 4.8 Reading Schematics and Symbols (Session #4800)

UNCONTROLLED IF PRINTED

5.0 Second Step

5.1 Steel Mains and Services (Session #2000)

- 5.1.1 Installation of Steel Pipe
- 5.1.2 Repair of Imperfections and Damage
- 5.1.3 Leak Clamps and Sleeves
- 5.1.4 Casings, Vents and Seals
- 5.1.5 Pressure Testing \geq 100 PSIG
- 5.1.6 Service Discontinuance
- 5.1.7 Farm Tap Design

5.2 Cathodic Protection (Session #2100)

- 5.2.1 Cathodic Protection System - Maintenance
- 5.2.2 Monitoring Atmospheric Corrosion
- 5.2.3 Coating Maintenance and Examination
- 5.2.4 Pipe to Soil Testing
- 5.2.5 Exothermic Welding
- 5.2.6 Hot Wraps / Epoxy Repair Sticks

5.3 Direct Operated Regulators and Reliefs, Customer Meters (Session #2200)

- 5.3.1 Locating, Installing and Protecting Customer Meters & Regulators
- 5.3.2 Customer Pressure Regulating and Limiting and Relief Devices
- 5.3.3 Operations and Maintenance of Regulators and Relief
- 5.3.4 Direct Operated Regulators and Reliefs
- 5.3.5 Valve Changing

5.4 Pipefitting (Session #2300)

- 5.4.1 Preventing Injuries When Wrenching
- 5.4.2 Calculating Offsets, Finding Set, Travel and Run
- 5.4.3 Flanges
- 5.4.4 TracPipe
- 5.4.5 Hand Threading, Power Threading
- 5.4.6 Wrenches, Joints and Threads

5.5 Equipment Operation (Session #2400)

- 5.5.1 Backhoe Operational Safety
- 5.5.2 Trencher Operational Safety
- 5.5.3 Equipment Operation
- 5.5.4 Sewer Listening Device

5.6 Electrical Measuring Instruments (TPC 204.1) (Session #4900)

UNCONTROLLED IF PRINTED

5.7 Basic Electricity and Electronics (TPC – 201) (Session #4950)

5.8 Valve Maintenance and Piping System Protection (TPC 347) (Session #5000)

6.0 Third Step

6.1 Evaluating Corrosion (Session #1800)

6.1.1 External Corrosion Above and Below Grade

6.1.2 Internal Corrosion

6.1.3 Pit Measurement

6.1.4 Pipe Damage

6.2 Troubleshooting (Session #1900)

6.2.1 Troubleshooting

6.2.2 Finding a Short

6.2.3 Testing Casings - Reverse Current

6.2.4 Current Requirement Tests

6.2.5 Stray Current Tests

6.2.6 Trouble Shoot and Repair a Rectifier

6.2.7 Conduct Soil Resistivity Tests

6.2.8 Conduct Close Order Surveys and Record Data, Draw Conclusions

6.2.9 Perform Insulator Tests

6.2.10 Read Bonds and Record Data

6.2.11 Measure Current and P/S at Anode Beds

6.3 Leak Investigation (Session #3100)

6.3.1 Flame Ionization Unit

6.3.2 Combustible Gas Indicator

6.3.3 Surveying and Patrols

6.3.4 Odorization

6.3.5 Outside Leak Investigations

6.3.6 Inside Leak Investigations

6.3.7 Carbon Monoxide Testing

6.3.8 Leak Documentation

6.4 Damage Prevention / Locating (Session #3300)

6.4.1 JULIE Law, Damage Prevention

6.4.2 Locating Theory and Principles

6.4.3 Conductive Locating

6.4.4 Inductive Locating (One Man and Two Man)

6.4.5 Inductive Clamp Locating

UNCONTROLLED IF PRINTED

6.4.6 Depth Calculation Using Triangulation

6.5 Complex Pressure Control (Pilot Operated Regulators and Reliefs) (Session #4100)

6.6 Hydrostatic Pressure Testing (Session #4200)

6.7 Odorizer Inspection and Maintenance (Session #4350)

6.8 Basic Pneumatic Skills (TPC 309) (Session #5050)

6.9 Developing Pneumatic Skills (TPC 310) (Session #5100)

6.10 Lockout / Tagout (Session #5150)

6.11 Pressure Test – Liquid Medium (Session #6000)

6.12 Compressors (Session #6500)

6.12.1 Compressor Start up and Shutdown - Manual

6.12.2 Compressor Preventive Maintenance

6.12.3 Reciprocating Compressor Inspection, Testing and Corrective Maintenance

6.13 Pumps (Session #6600)

6.13.1 Pump Start-up and Shutdown

6.13.2 Pump Preventive Maintenance

6.13.3 Centrifugal Pump Inspection/Testing and Corrective Maintenance

6.13.4 Reciprocating Pump Inspection/Testing/Corrective Maintenance

6.14 Overfill Protection Systems (Session #6750)

6.15 Explosive Atmosphere Detection and Alarm System Performance Test / Corrective Maintenance (Session #6800)

6.16 Breakout Tanks (Session #6850)

7.0 Additional Training (Required)

7.1 Fire Fighting Training (Session #4850)

8.0 Additional Training (Optional)

8.1 PE Mains and Services (Session #1100)

8.2 Purdue Basics (Corrosion) (Session #2600)

8.3 Tapping and Stopping (Session #3000)

8.4 Leak Investigation (Session #3100)

8.5 Customer Premise (Session #3200)

8.6 OAS Training (Session #4000)

8.7 Byers Mapping Training (Session #4050)

8.8 Rectifier Inspection and Maintenance (Session #4150)

8.9 Coating Application (Sprayed) (Session #4250)

8.10 Fit-up Weld Repair Sleeve (Session #4300)

8.11 Mobile Leak Survey (Session #4400)

- 8.12 Gas Control Operations (Session #4450)
- 8.13 Gas Storage Operations (Session #4500)
- 8.14 Large Diameter Tapping (Session #4600)
- 8.15 Advanced Appliance Operations (Session #4650)
- 8.16 Reciprocating Compressors (Session #5200)
- 8.17 Fundamental of Programmable Logic Controllers (Session #5250)
- 8.18 Excel XP Level 1 (Val-Tech) (Session #5300)
- 8.19 Dehydration (Session #5310)

End of Instructions

Operator Qualification (OQ) Required?

YES

Refer to Appendices

Appendices

[Appendix A - ASME B31Q Operator Qualifications Performed at the end of First Step](#)

[Appendix B - ASME B31Q Operator Qualifications Performed at the end of Second Step](#)

[Appendix C - ASME B31Q Operator Qualifications Performed at the end of Third Step](#)

Attachments

NONE

Compliance Requirements

49 CFR §192.805 Qualification of Pipeline Personnel: Qualification Program

Reference Documents

NONE

Document Rescission

APPR 2.02 Apprentice Training: Gas Storage, February 1, 2010

Revision Notes Location	Summary of Changes
Entire document	Format of document has been changed to match the format of October 2022 Issue

Subsection 4.4	Working In Gaseous Environment replaces Working With Blowing Gas
Appendix C – 3rd Step	<p>Added Covered Tasks:</p> <p>1381- Operate Gas Pipeline – Local Facility Remote=Control Operations</p> <p>1631 - Launching and or receiving internal Device (pigs) lines out of service</p> <p>1641 - Launching and or receiving internal Device (pigs) lines in of service</p> <p>1671 - Inspect & Maintain a Pipeline Heater</p> <p>1681 - Inspect & Maintain Liquid Knockout System</p> <p>1691 - Inspect & Maintain Glycol Dehydration System</p> <p>1701 - Inspect & Maintain Mole Sieve Dehydration System</p>

Appendix A- ASME B31Q Operator Qualifications Performed at the end of First Step

ASME B31Q Number	Covered Task Description
0211	Measure and Characterize Mechanical Damage on Installed Pipe and Components
0561	Pressure Test - Non-liquid Medium < 100 psig
0591	Leak Test at Operating Pressure
0641	Visually Inspect Pipe and Components Prior to Installation
0981	Backfilling
0991	Coating Application and Repair - Brushed or Rolled
0301	Manually Opening and Closing Valves
0311	Adjust and Monitor Flow or Pressure - Manual Valve Operation
0321	Valve Corrective Maintenance

0331	Valve - Visual Inspection and Partial Operation
0341	Valve Maintenance

Appendix B, ASME B31Q Operator Qualifications Performed at the end of Second Step

ASME B31Q Number	Covered Task Description
0001	Measure Structure-to-Electrolyte Potential
0041	Installation and Maintenance of Mechanical Connections
0051	Installation of Exothermic Electrical Connections
0081	Install Cathodic Protection Electrical Isolation Devices
0201	Visual Inspection of Installed Pipe and Components for Mechanical Damage
0141	Corrosion Monitoring - Atmospheric, External and Corrosion Internal
0151	Visual Inspection of Buried Pipe and Components when Exposed
0161	Visual Inspection for Internal Corrosion
0171	Measure External Corrosion
0181	Measure Internal Corrosion
0191	Measure Atmospheric Corrosion
0381	Spring Loaded Pressure Regulating Device - Inspect, Testing, Preventive & Corrective Maintenance
0411	Spring-Loaded Pressure Limiting and Relief Device- Inspect, Testing, Preventive & Corrective Maintenance
0571	Pressure Test - Non-liquid Medium \geq 100 psig
0721	Joining of Pipe - Threaded Joints

UNCONTROLLED IF PRINTED

0731	Joining of Pipe - Flange Assembly
0861	Installation of Steel Pipe in a Ditch
0951	Installation of Pipe Above Ground
0971	Installation/Maintenance Casing spacers vents seals
1011	External Coating Application and Repair - Wrapped
1191	Maintenance Valves Upstream of Customer Meter
1341	Provide or Assure Adequate Pipeline Support During Operator Initiated Excavation Activities
0961	Above Ground Supports and Anchors - Inspection, Preventive/Corrective Maintenance
1301	Install and Maintain Pipeline Markers
1321	Damage Prevention During Excavation Activities by or on Behalf of the Operator
1331	Damage Prevention Inspection During Third Party Excavation or Encroachment Activities as Determined Necessary by Operator

Appendix C, ASME B31Q Operator Qualifications Performed at the end of Third Step

ASME B31Q Number	Covered Task Description
1261	Walking Gas Leakage Survey
1291	Locating Underground Pipelines
1311	Inspect Pipeline Surface Conditions - Patrol Right of Way or Easement
0391	Pilot-Operated Pressure Regulating Device -Inspect, Testing, Preventive & Corrective Maintenance

UNCONTROLLED IF PRINTED

0421	Pilot Operated Pressure Limiting/Relief Device-Inspect, Testing, Preventive & Corrective Maintenance
0431	Pneumatic Loaded Pressure Limiting/Relief Device-Inspect, Testing, Preventive & Corrective Maintenance
0581	Pressure Test - Liquid Medium
1221	Odorization - Odorizer Inspection, Testing, Preventive/Corrective Maintenance
0091	Troubleshoot In-service cathodic Protection System
0121	Collect Sample for Internal Corrosion Monitoring
0131	Insert and Remove Coupons/Probes for Internal Corrosion
0221	Inspect, Test and Maintain Sensing Devices
0251	Inspection/Testing, Corrective/Preventive Maintenance - Overfill Protection Systems
0261	Inspection, Testing, Corrective/Preventive Maintenance - Tank Gauges for Leak Detection
0361	Electric Actuator/Operator Inspection and Testing Preventive/Corrective Maintenance
0371	Hydraulic Actuator/Operator Inspect/Testing, Preventive/Corrective Maintenance
0401	Controller Type Pressure Regulating Device - Inspect, Testing, Preventive & Corrective Maintenance
0441	Compressor Start up and Shutdown - Manual
0451	Pump Start-up and Shutdown
0461	Compressor Preventive Maintenance
0471	Reciprocating Compressor Inspection, Testing and Corrective Maintenance
0501	Pump Preventive Maintenance

UNCONTROLLED IF PRINTED

0511	Centrifugal Pump Inspection/Testing and Corrective Maintenance
0521	Reciprocating Pump Inspection/Testing/Corrective Maintenance
0551	Explosive Atmosphere Detection and Alarm System Performance Test/Corrective Maintenance
0821	Tubing and Fitting Installation - Instrument, Control and Sampling
1361	Station Emergency Shutdown System - Inspection, Testing and Corrective Maintenance
1381	Operate Gas Pipeline – Local Facility Remote=Control Operations
1631	Launching and or receiving internal Device (pigs) lines out of service
1641	Launching and or receiving internal Device (pigs) lines in of service
1671	Inspect & Maintain a Pipeline Heater
1681	Inspect & Maintain Liquid Knockout System
1691	Inspect & Maintain Glycol Dehydration System
1701	Inspect & Maintain Mole Sieve Dehydration System

1.0 Purpose

This section outlines the formal training programs for new gas field personnel in Gas Technical Services. This is accomplished using a blended training approach of CBT's, Classroom Instruction, Hands-On and Safe Start Principles.

2.0 Scope

This document addresses the following:

[Section 3.0 – Target Audience](#)

[Section 4.0 – First Step](#)

[Section 5.0 – Second Step](#)

[Section 6.0 – Third Step](#)

Appendices:

[Appendix A - ASME B31Q Operator Qualifications Performed at the end of First Step](#)

[Appendix B - ASME B31Q Operator Qualifications Performed at the end of Second Step](#)

[Appendix C - ASME B31Q Operator Qualifications Performed at the end of Third Step](#)

3.0 Target Audience

- Gas Training Personnel
- Gas Operator Qualifications Personnel
- Gas Tech Services (GTS) Supervisor
- Gas Tech Services (GTS) Personnel

4.0 First Step

4.1 Operation and Maintenance of Distribution Regulator Station Equipment (Session #1000)

4.1.1 Functions of a Regulator

4.1.2 Essential Elements

4.1.3 Regulators: Spring Loaded, Pilot Loaded, Controller and Actuator Type

4.1.4 Overpressure Protection: Relief Valves, Monitor Systems, Security Valves

4.1.5 Regulator Station Inspections and By-Pass Operations, ERX, Program

4.2 Operation and Maintenance of Transmission Regulator Station and Measuring Equipment (Session #1100)

4.2.1 Flow Meters-Orifice Metering

4.2.2 Pipeline Heaters

4.2.3 Filtering Equipment

4.2.4 Electronic Controllers

4.2.5 Pneumatic Controllers

4.2.6 Standby and Back Up Systems

4.2.7 Pressure Monitoring Distribution and Transmission

4.3 Gas System (Session #1200)

4.3.1 Components of the Total Gas System, Producer, Intrastate Pipeline, Distribution Company

4.3.2 Components of Ameren Illinois Gas System, Pipeline Interface, Transmission System, Distribution System, Gas Storage Facilities, Review Gas System Study

4.4 Operation and Filing of Odorizing Equipment (Session #1300)

4.4.1 Injection Pumps

4.4.2 Differential Meter Type

4.4.3 Bypass

4.4.4 Odorant Testing and Sampling

4.4.5 Odorant Requirements

4.4.6 Odorization Requirements

4.5 Metering, Instrumentation Operation, Maintenance and Calibration (Session #1400)

4.5.1 Gauges, Spring, Electronic, Recording, Manometer

4.5.2 Electronic Correctors

4.5.3 Differential and Accuracy Testing, Roots Program, Record Keeping, Oil Changing

4.5.4 Types of Meters, Diaphragm, Rotary, Turbine, Orifice, Ultrasonic

4.5.5 Meter Testing Programs, Sample Testing, Periodic Testing, Mileage Testing

4.5.6 New Meter Testing

5.0 Second Step

5.1 Operation and Maintenance of a Distribution Regulator Station and Equipment (Session #2000)

5.1.1 Regulators: Spring Loaded Regulators, Types, Uses, Pilot Loaded Regulators, Types, Uses, Controller and Actuator type

5.1.2 Over Pressure Protection: Relief Valves, Spring, Pilot, Security Valves

5.1.3 Monitor Regulator System, Uses, Types-Open and Working, Piping Configurations

5.2 Operation and Maintenance of Transmission – Regulator Stations and Measuring Equipment (Session #2100)

5.2.1 Flow Meters-Orifice Metering: Uses, Types

5.2.2 Filtering Equipment

UNCONTROLLED IF PRINTED

5.2.3 Electronic Controllers: Uses-Types-Inspections

5.2.4 Pneumatic Controllers: Uses-Types-Inspections

5.2.5 Standby and Back up systems

5.2.6 Pipeline Heaters: Maintenance

5.2.7 Systematic Checks

5.3 Operation and Filing of Odorizing Equipment (Session #2200)

5.3.1 Injection Pump, Bypass, Differential Meter: Reading, Filling, Field Inspections, Record Keeping

5.3.2 Odorant Testing and Sampling: When, Where, Why

5.3.3 Use of Odorometer and Odorator

5.4 Construction (Session #2300)

5.4.1 Read and Understand Blueprints for Station Construction: Symbols Used, Measurement, Fittings, Construction Standards

5.4.2 Station Installations and Set-Up for Operation

5.4.3 Station Prefabrication

5.4.4 Testing of Station and Equipment: Pressure Limits, Recording Devices, Hydrostatic Testing, Nitrogen Testing

5.4.5 Proper Placement of Control Lines: Distribution and Transmission Stations Industrial Meter Sets

5.5 Metering, Instrumentation Operation, Maintenance and Calibration (Session #2400)

5.5.1 Electronic Correctors: Inspections, Calibrate, Record Keeping, Review Electronic Corrector Inspection Gas Metering Procedure

5.5.2 AMR Devices

5.5.3 Pulse Accumulators

5.5.4 USMS Accounts

5.5.5 Meter Testing: Diaphragm, Rotary, Turbine, Ultrasonic, Orifice

5.5.6 Review Gas Metering Procedures Associated with Field Testing

6.0 Third Step

6.1 Operation and Maintenance of Distribution Regulator Station and Equipment (Session #3000)

6.1.1 Systematic Checks

6.1.2 Catalytic Heaters

6.1.3 Erx: Calibrate, Maintenance

6.1.4 Upgrading and Uprating of System Pressures-Review Procedures

6.2 Operation and Maintenance of Transmission – Regulator Stations and Measuring Equipment (Session #3100)

6.2.1 Generators and Backup Equipment, Maintenance Inspections

6.2.2 Gas Transmitters-Pressure and Differential Pressure: Program, Calibrate

UNCONTROLLED IF PRINTED

6.2.3 Telemetry Equipment

6.2.4 Remote Operating Controllers (ROC's, RTU's, HP's)

6.2.5 Rerouting Gas for Efficient Operation of Storage Facilities

6.2.6 Rerouting Gas for Construction and Emergency Operations

6.3 Operation and Filing of Odorization Equipment (Session #3200)

6.3.1 YZ Data Download

6.3.2 Odorant Transfer-Bulk and Portable Tank

6.3.3 Pump-Maintenance and Rebuild

6.3.4 Troubleshooting

6.3.5 Cleaning Up Spills and Deodorizing

6.4 Metering, Instrumentation Operation, Maintenance and Calibration (Session #3300)

6.4.1 Correctors: Program, Modems, Troubleshoot

6.4.2 AMR devices: Program, Wire, Troubleshoot

6.5 Basic Electronics Course (Session #3400)

End of Instructions

Operator Qualification (OQ) Required?

YES

Refer to the Appendices

Appendices

[Appendix A - ASME B31Q Operator Qualifications Performed at the end of First Step](#)

[Appendix B - ASME B31Q Operator Qualifications Performed at the end of Second Step](#)

[Appendix C - ASME B31Q Operator Qualifications Performed at the end of Third Step](#)

Attachments

NONE

Compliance Requirements

49 CFR §192.805 Qualification of Pipeline Personnel: Qualification Program

Reference Documents

NONE

Document Rescission

APPR 2.04 Apprentice Training: Gas Technical Services, January 1, 2011

UNCONTROLLED IF PRINTED

Revision Notes

Location of Changes	Summary of Changes
Entire document	Format of document has been changed to match the format of October 2022 Issue
Paragraph 4.2.2	Pipeline Heaters replaces Pipeline Boilers
Appendix C – 3rd Step	<p>Added Covered Tasks:</p> <p>0371 - Hydraulic Actuator/Operator Inspection and Testing, Preventive and Corrective Maintenance</p> <p>1381 - Operate Gas Pipeline – Local Facility Remote=Control Operations</p> <p>1631 - Launching and/or Receiving Internal Devices (Pigs) with a temporary launcher and/or receiver for Lines Out of Service</p> <p>1641 - Launching and/or Receiving Internal Devices (Pigs) for Lines in Service</p> <p>1671 - Inspect and Maintain a Pipeline Heater</p>

Appendix A, ASME B31Q Operator Qualifications Performed at the end of First Step

ASME B31Q Number	Covered Task Description	IP	CIPS	CIL-CO
0011	Conduct Close Interval Survey		X	
0021	Measure Soil Resistivity		X	

UNCONTROLLED IF PRINTED

0211	Measure and Characterize Mechanical Damage on Installed Pipe and Components	X		X
0301	Manually Opening and Closing Valves	X	X	X
0311	Adjust and Monitor Flow or Pressure-Manual Valve Operation	X	X	X
0321	Valve Corrective Maintenance	X	X	X
0331	Valve - Visual Inspection and Partial Operation	X	X	X
0341	Valve - Preventive Maintenance	X	X	X
0381	Spring Loaded Pressure Regulating Device - Inspect, Testing, Preventive & Corrective Maintenance	X	X	X
0411	Spring-Loaded Pressure Limiting and Relief Device - Inspect, Testing, Preventive & Corrective Maintenance	X	X	X
0561	Pressure Test - Non-liquid Medium - MAOP Less Than 100 PSIG	X	X	X
0591	Leak Test at Operating Pressure	X	X	X
0641	Visually Inspect Pipe and Components Prior to Installation	X	X	X
0691	Joining of Pipe - Non-Bottom Out Compression Couplings	X	X	X
0701	Joining of Pipe - Bottom Out Compression Couplings	X	X	X
0751	Joining of Plastic Pipe - Butt Heat Fusion: Manual	X		

UNCONTROLLED IF PRINTED

0761	Joining of Plastic Pipe - Butt Heat Fusion: Hydraulic Machine	X		
0781	Joining of Plastic Pipe - Electrofusion	X		
0901	Installation of Plastic Pipe in a Ditch	X		
0911	Installation of Plastic Pipe in a Bore	X		
0921	Installation of Plastic Pipe Plowing/Pull In	X		
0941	Install Tracer Wire	X	X	X
0981	Backfilling	X	X	X
0991	Coating Application and Repair - Brushed or Rolled	X	X	X
1141	Squeeze Off Plastic Pipe	X		
1201	Temporary Isolation of Service Lines and Service Discontinuance	X	X	X
1211	Odorization - Periodic Sampling	X	X	X
1221	Odorization - Odorizer Inspection, Testing, Preventive and Corrective Maintenance	X	X	X

Appendix B, ASME B31Q Operator Qualifications Performed at the end of Second Step

UNCONTROLLED IF PRINTED

ASME B31Q Num- ber	Covered Task Description	IP	CIPS	CIL- CO
0001	Measure Structure to Electrical Potential	X	X	
0041	Install and Maintain Mechanical Electrical Connections	X	X	
0051	Install Exothermic Electrical Connections	X	X	X
0081	Install Cathodic Protection Electrical Isolation Devices			
0091	Troubleshoot In-Service Cathodic Protection System		X	
0111	Maintain Rectifier		X	
0141	Visual Inspection for Atmospheric Corrosion	X	X	X
0151	Visual Inspection of Buried Pipe and Components When Exposed	X	X	X
0161	Visual Inspection for Internal Corrosion	X	X	X
0171	Measure External Corrosion	X	X	X
0181	Measure Internal Corrosion	X	X	X
0191	Measure Atmospheric Corrosion	X	X	X
0201	Visual Inspection of Installed Pipe and Components for Mechanical Damage	X	X	X

UNCONTROLLED IF PRINTED

0221	Inspect, Test and Maintain Sensing Devices	X	X	X
0261	Inspection, Testing, Corrective and Preventive Maintenance - Tank Gauges for Leak Detection	X	X	X
0391	Pilot-Operated Pressure Regulating Device -Inspect, Testing, Preventive & Corrective Maintenance	X	X	X
0421	Pilot Operated Pressure Limiting and Relief Device - Inspect, Testing, Preventive & Corrective Maintenance	X	X	X
0571	Pressure Test - Non-liquid Medium - MAOP Greater Than or Equal to 100 PSIG	X	X	X
0721	Joining of Pipe - Threaded Joints	X	X	X
0731	Joining of Pipe - Flange Assembly	X	X	X
0821	Tubing and Fitting Installation - Instrument, Control and Sampling	X	X	X
0861	Installation of Steel Pipe in a Ditch	X	WEST-X	
0871	Installation of Steel Pipe in a Bore	X	WEST-X	
0881	Installation of Steel Pipe Plowing / Pull In	X	WEST-X	
0951	Installation of Pipe Above Ground	X	X	X
0961	Above Ground Supports and Anchors - Inspection, Preventive and Corrective Maintenance	X	X	X

UNCONTROLLED IF PRINTED

0971	Installation and Maintenance of Casing Spacers, Vents and Seals	X	X	
1011	External Coating Application and Repair - Wrapped	X	X	X
1041	Install Mechanical Clamps and Sleeves - Bolted	X	X	X
1151	Squeeze Off Steel Pipe	X	WEST-X	
1161	Installation of Customer Meters and Regulators - Residential and Small Commercial	X	X	
1171	Installing Customer Meters - Large Commercial and Industrial	X	X	X
1181	Install and Maintain Customer Pressure Regulating, Limiting & Relief Device-Large Commercial & Industrial	X	X	X
1191	Maintenance of Service Valves Upstream of Customer Meter	X	X	
1251	Hazardous Liquid Leak Investigation	X	X	X
1291	Locate Underground Pipelines	X	X	X
1301	Install and Maintain Pipeline Markers	X	X	X
1321	Damage Prevention During Excavation Activities by or on Behalf of the Operator	X	X	X
1331	Damage Prevention Inspection During Third Party Excavation or Encroachment Activities as Determined Necessary by Operator	X	X	X

UNCONTROLLED IF PRINTED

1341	Provide or Assure Adequate Pipeline Support During Operator Initiated Excavation Activities	X	X	X
1361	Station Emergency Shutdown system - Inspection, Testing and Corrective Maintenance	X	X	X
1421	Direct Examination Techniques	X	X	X

Appendix C, ASME B31Q Operator Qualifications Performed at the end of Third Step

ASME B31Q Number	Covered Task Description	IP	CIPS	CIL-CO
0031	Inspect and Monitor Galvanic Ground Beds		X	
0061	Inspect or Test Cathodic Protections Bonds		X	
0071	Inspect or Test Cathodic Protection Electrical Isolation Beds		X	
0101	Inspect Rectifier and Obtain Readings	SOUTH	X	
0121	Collect Sample for Internal Corrosion Monitoring	X	X	X
0131	Insert and Remove Coupons/Probes for Internal Corrosion Monitoring		X	
0351	Pneumatic Actuator/Operator Inspection and Testing, Preventive and Corrective Maintenance	X	X	X

0361	Electric Actuator/Operator Inspection and Testing, Preventive and Corrective Maintenance	X	X	X
0371	Hydraulic Actuator/Operator Inspection and Testing, Preventive and Corrective Maintenance	X	X	X
0431	Pneumatic Loaded Pressure Limiting/Relief Device-Inspect, Testing, Preventive & Corrective Maintenance	X	X	X
0811	Visual Inspection of Welding and Welds	X	X	X
1081	Tapping a Pipeline (Tap Diameter 2 Inch and Less)	X	X	
1091	Tapping a Pipeline (Tap Diameter Greater than 2 Inch)	X	X	
1131	Stopper (Stopp) Pipe	X		
1241	Outside Gas Leak Investigation	X	X	X
1311	Inspect Pipeline Surface Conditions - Patrol Right of Way or Easement	X	X	
1351	Vault Inspection and Maintenance	X	X	X
1381	Operate Gas Pipeline – Local Facility Remote=Control Operations	X	X	X
1631	Launching and/or Receiving Internal Devices (Pigs) with a temporary launcher and/or receiver for Lines Out of Service	X	X	X
1641	Launching and/or Receiving Internal Devices (Pigs) for Lines in Service	X	X	X
1671	Inspect and Maintain a Pipeline Heater	X	X	X

UNCONTROLLED IF PRINTED

1.0 Purpose

This section outlines the formal training programs for gas personnel and non-gas personnel who are designated as an Emergency Responder.

2.0 Scope

This document addresses the following:

[Section 3.0 – Target Audience](#)

[Section 4.0 – Curriculum](#)

3.0 Target Audience

- Gas Training Personnel
- Gas Operator Qualification Personnel
- Gas Apprentices
- Designated Emergency Responders
- Gas Supervisors
- Electric Supervisors with Emergency Responder Personnel
- Meter Changer Supervisors

4.0 Curriculum

4.1 Gas Basics (Session #1000)

- 4.1.1 Abnormal Operating Conditions
- 4.1.2 Direct Observation
- 4.1.3 Drug and Alcohol Compliance
- 4.1.4 Personal Protective Equipment
- 4.1.5 Characteristics and Hazards of Natural Gas
- 4.1.6 Recognizing Gas Emergencies
- 4.1.7 Recognizing and Reporting Gas Leaks
- 4.1.8 Disconnect Customer Services

Operator Qualification (OQ) Required?

YES

1201: Disconnect Customer Services

Appendices

NONE

Attachments

NONE

Compliance Requirements

49 CFR §192.805 Qualification of Pipeline Personnel: Qualification Program

Reference Documents

NONE

Document Rescission

APPR 2.05 Apprentice Training: Emergency Responder Program, January 1, 2011

Revision Notes

Location of Changes	Summary of Changes
Entire document	Format of document has been changed to match the format of October 2022 Issue

1.0 Purpose

This section outlines the formal training programs for the Gas Meter Specialist Program and Gas Meter Reader Program for new gas field personnel.

2.0 Scope

This document addresses the following:

[Section 3.0 – Target Audience](#)

[Section 4.0 – Gas Meter Reader Program Curriculum](#)

[Section 5.0 – Gas Meter Specialist Program Curriculum](#)

Appendices

[Appendix A – Qualifications](#)

[Appendix B – OJT Summary](#)

[Appendix C – \(OJT\) Breakdown by Type of Work with Associated B31Q Covered Task](#)

3.0 Target Audience

- Gas Training Personnel
- Gas Operator Qualifications Personnel
- Gas Meter Readers
- Gas Meter Specialists

4.0 Gas Meter Reader Program Curriculum

4.1 Gas Basics (Session #1000)

- 4.1.1 Abnormal Operating Conditions
- 4.1.2 Direct Observation
- 4.1.3 Drug and Alcohol Compliance
- 4.1.4 Personal Protective Equipment
- 4.1.5 Characteristics and Hazards of Natural Gas
- 4.1.6 Recognizing Gas Emergencies
- 4.1.7 Recognizing and Reporting Natural Gas Leaks
- 4.1.8 Meter Set Inspection

5.0 Gas Meter Specialist Program Curriculum

5.1 The Gas Meter Specialist Program includes all the courses required for the Gas Meter Reader Program as well as the following:

5.1.1 Direct Operated Regulators and Reliefs, Customer Meters (Session #1500)

1. Locating, Installing and Protecting Customer Meters and Regulators
2. Customer Pressure Regulating, Limiting and Relief Devices

5.1.2 Pipefitting (Session #2300)

1. Preventing Injuries When Wrenching
2. Wrenches, Joints and Threads

5.1.3 Customer Premise (Session #3200)

1. Combustion and Ventilation Air
2. Venting
3. Pilots
4. Control Valves
5. Gas-Air Adjustments
6. Lighting Appliances
7. Code Violations and Hazardous Conditions
8. Pressure Checks, Delivery and Lock-Up
9. Low Flow and Shut-In Test
10. Turn On Gas
11. Track Pipe Recognition

End of Instructions

Operator Qualification (OQ) Required?

YES

Refer to Appendix A

Appendices

[Appendix A – Qualifications](#)

[Appendix B – OJT Summary](#)

[Appendix C – \(OJT\) Breakdown by Type of Work with Associated B31Q Covered Task](#)

Attachments

NONE

Compliance Requirements

49 CFR §192.805 Qualification of Pipeline Personnel: Qualification Program

Reference Documents

NONE

UNCONTROLLED IF PRINTED

Document Rescission

APPR 2.06 Apprentice Training: Gas Meter Specialist Program, January 1, 2016

APPR 2.07 Apprentice Training: Gas Meter Reader Program, February 1, 2010

Revision Notes

Location of Changes	Summary of Changes
Entire document	Format of document has been changed to match the format of October 2022 Issue

Appendix A, Qualifications

A-1. ASME B31Q Operator Qualifications Performed at the End of the Program

ASME B31Q Number	Covered Task Description
0991	Coating Application and Repair - Brushed or Rolled
1201	Disconnect Customer Services
0141	Corrosion Monitoring - Atmospheric, External and Corrosion Internal
1161	Install Meters and Regulators - Residential, Small Commercial

A-2. Note: Only ASME B31Q Number 0141 is required for the Gas Meter Reader Program

Appendix B, Gas Meter Specialist OJT Summary

B-1. Minimum OJT Summary

Type Of Work	Program Minimum OJT Hours
Cathodic Protection	24
Service Work	56
Pressure Control	32

UNCONTROLLED IF PRINTED

Appendix C, (OJT) Breakdown by Type of Work with Associated B31Q Covered Task for Meter Specialist

Type Of Work	B31Q Covered Task and Description
Cathodic Protection	0991, Coating Application and Repair Brushed and Rolled 0141, Visual Inspection for Atmospheric Corrosion 0191, Measure Atmospheric Corrosion 1011, External Coating Application and Repair-Wrapped
Service Work	1201, Disconnect Customer Service 1161, Install Meters and Regulators- Residential and Small Commercial
Pressure Control	0381, Spring Loaded Pressure Regulating Devices - Inspection and Testing, Preventative and Corrective Maintenance

APPRENTICE TRAINING

October 1, 2022

APPR 2.7 Hiring Gas Field Personnel

1.0 Purpose

- 1.1 To successfully perform the duties required of gas field personnel, employees must have certain basic skills and abilities.
- 1.2 This section describes the evaluation tools and the hiring process that Ameren Illinois utilizes to evaluate and screen applicants for the various contract positions that are collectively referred to as "Gas Field Personnel".
- 1.3 This section also outlines the process by which applicants with previous gas experience are evaluated for placement within Ameren Illinois' Apprenticeship Program or qualified as a Journeyman.

2.0 Scope

This document addresses the following:

[Section 3.0 – Target Audience](#)

[Section 4.0 – General](#)

[Section 5.0 – Evaluation Tools](#)

[Section 6.0 – Hiring Process](#)

3.0 Target Audience

- Gas Training Personnel
- Gas Operator Qualification Personnel
- Gas Superintendents
- Gas Supervisors

4.0 General

- 4.1 The term "Applicant(s)" in this section shall mean all external applicants plus all internal applicants that have no union affiliation or a union affiliation different than the one where the opening exists.
- 4.2 The following procedures will be applied to all applicants from outside Ameren Illinois or Ameren Missouri.
- 4.3 These procedures will also be applied to internal employee applicants if permitted by the affected labor contract.
- 4.4 An existing employee who is not a member of a bargaining unit, or who is a member of a bargaining unit different from the one where the opening exists, will be evaluated under the terms of this section.

5.0 Evaluation Tools

5.1 Construction and Skilled Trades (CAST) Testing

- 5.1.1 The CAST test is a written examination designed to predict an applicant's probability of success in a construction and skilled trade position.

UNCONTROLLED IF PRINTED

5.1.2 All applicants for gas field personnel positions are required to successfully complete the CAST test prior to being given further consideration in the hiring process.

5.1.3 Applicants completing the CAST test will be classified as either "Recommended" or "Not Recommended".

5.2 Gas Evaluations (Gas E.V.'s)

5.2.1 The Gas E.V.'s are physical evaluations designed to assess whether or not an applicant has the basic physical strength, endurance and coordination required by an entry level gas field personnel position.

5.2.2 All applicants for gas field personnel positions are required to successfully complete the Gas E.V.'s before being given further consideration in the hiring process.

5.2.3 Applicants participating in the Gas E.V.'s will be classified as either "Recommended" or "Not Recommended".

5.3 Operator Qualification Testing (O.Q. Testing)

5.3.1 This evaluation tool will be used only for those applicants with past gas related experience.

5.3.2 The purpose of the O.Q. testing is to evaluate past experience such that, if the applicant is subsequently placed in the position, the precise starting point within the Apprenticeship Program may be determined.

5.3.3 As an example, if an applicant with previous experience is able to demonstrate proficiency through the O.Q. testing process, he/she may be started as a second or third step apprentice (potentially even a Journeyman) rather than as a first step apprentice.

6.0 Hiring Process

6.1 When the normal bidding process has failed to identify a successful bidder for an open gas field personnel position, the following process will be used to consider other applicants for the position:

6.1.1 The hiring location will contact the Staffing Department of the Human Resources function.

1. The Staffing Department and the hiring location will discuss the pool of applicants currently available and determine if additional recruiting is needed.
2. Once candidates have been identified, the Staffing Department will assist the hiring location in administering the CAST test to all applicants.
3. Applicants receiving a "Recommended" score from the CAST test will be asked to complete an employment application.

6.1.2 Once the application is received, the Staffing Department will initiate criminal and reference background checks.

NOTE:	Since background checks may take several weeks to complete, final results are not always available before an offer of employment is extended
--------------	--

6.1.3 Applicants receiving a "Recommended" score from the CAST test will be interviewed by the hiring location.

- 6.1.4 All interviews will be properly documented. Based upon the interview results, none, some or all of the applicants may be selected for further evaluation utilizing the Gas E.V.'s.
- 6.1.5 Applicants selected for further evaluation will be scheduled for the Gas E.V. testing at the Pawnee Training Center.
1. Each such applicant will be sent a letter by the Staffing Department that describes each of the activities included in the Gas E.V. test.
 2. The estimated time required to complete the Gas E.V.'s is approximately eight hours.
 3. It is recommended that a gas supervisor from the hiring location observe the Gas E.V. testing, however, supervisors from the hiring location may not participate in the actual evaluation of the applicant.
 4. Applicants involved in the Gas E.V.'s will be scored as "Recommended" or "Not Recommended".
- 6.1.6 Applicants with prior gas experience who receive a "Recommended" score from the Gas E.V.'s may also be further evaluated at Pawnee to establish placement within the Apprenticeship Program, up to and including certification as a Journeyman.
- 6.1.7 After consultation with the Staffing Department, the hiring location will make the final selection from the applicants that have received a "Recommended" score from both the CAST test and the Gas E.V.'s.
- 6.1.8 If the offer is to be made to an applicant with prior gas experience, the Pawnee Training staff will advise the hiring location of the appropriate starting position based upon the results of the O.Q. testing.

End of Instructions

Operator Qualification (OQ) Required?

NO

Appendices

NONE

Attachments

NONE

Compliance Requirements

49 CFR §192.805 Qualification of Pipeline Personnel: Qualification Program

Reference Documents

NONE

Document Rescission

APPR 2.08 Apprentice Training: Hiring Gas Field Personnel, January 1, 2011

UNCONTROLLED IF PRINTED

Revision Notes

Location of Changes	Summary of Changes
Entire document	Format of document has been changed to match the format of October 2022 Issue

BORE-Boring

BORING

October 1, 2021

BORE 0 Table of Contents

BORE 1 Boring: Location Criteria and Requirements

- Section 1.0 Purpose
- Section 2.0 Scope
- Section 3.0 Target Audience
- Section 4.0 Boring Operations
- Section 5.0 Boring Site Evaluation
- Section 6.0 Bore Site Preparation
 - Operator Qualification
 - Compliance Requirements
 - Reference Documents
 - Document Rescission

BORE 2.1 Boring: Boring Operations and Pipe Installation

- Section 1.0 Purpose
- Section 2.0 Scope
- Section 3.0 Target Audience
- Section 4.0 Boring Operations
- Section 5.0 Conventional Rod Boring
- Section 6.0 Pneumatic Piercing Tool Boring
- Section 7.0 Directional Drilling
- Section 8.0 Auger Boring and Jack & Bore Method
- Section 9.0 Pipe Installation
 - Operator Qualification
 - Compliance Requirements
 - Reference Documents
 - Document Rescission

BORE 2.2 Boring: Boring Across or Near Sewer Lines

- Section 1.0 Purpose
- Section 2.0 Scope

UNCONTROLLED IF PRINTED

Section 3.0 Target Audience

Section 4.0 General Requirements

Section 5.0 Pre-Construction Steps

Section 6.0 Camera Inspection of High-Risk Sewer Laterals

Section 7.0 Construction Steps

Section 8.0 Sewer Cleaning Notification

Section 9.0 Response to Inquiries

Operator Qualification

Compliance Requirements

Reference Documents

Document Rescission

Appendices

Appendix A - Typical Sewer Installations

Appendix B - Sample Door Tag

Appendix C - Sample Cross Bore Brochure

BORE 3 - Boring: Forms and Reference Materials

References

Document Rescission

End Table of Contents.

Document Rescission

BORE 0 Boring: Table of Contents, October 1, 2020.

Revision Notes

Location of Changes	Summary of Changes
BORE 2.1	New sections added for each Boring Method and for Pipe Installation.

BORE 1 Location Criteria and Requirements

1.0 Purpose

This document provides the requirements and location criteria for boring in accordance with 49 CFR §§ 192.325 and 192.361.

2.0 Scope

This document addresses the following:

[3.0 Target Audience](#)

[4.0 Boring Operations](#)

[5.0 Boring Site Evaluation](#)

[6.0 Bore Site Preparation](#)

3.0 Target Audience

- Gas Engineering
- Gas Distribution Design Specialists
- Gas Construction Personnel
- Gas Supervisors
- Gas Construction Services Personnel

4.0 Boring Operations

4.1 Boring refers to:

4.1.1 Underground lateral displacement of soil by mechanical means from one tap hole to another tap hole

or

4.1.2 Underground lateral displacement of soil by mechanical means which enters the ground surface at one location and exits the ground surface at a different location.

4.2 Bore, when possible, across:

4.2.1 State highways

4.2.2 Railroads

4.2.3 Paved streets

4.2.4 Roads

4.2.5 Paved driveways

4.2.6 Waterways

4.2.7 Other obstructions.

4.3 Boring operations must be conducted in such a manner to:

4.3.1 Protect the safety of the general public, customers and employees.

UNCONTROLLED IF PRINTED

- 4.3.2 Avoid damage to all other underground utilities and structures.
- 4.3.3 Prevent damage to or excessive stresses or strain on the gas pipeline being installed.

Only Operator Qualified equipment operators should operate or be in direct observation of the operation of the boring equipment.

- 4.4 There are four (4) boring methods:
 - 4.4.1 Conventional bore with bore rods
 - 4.4.2 Pneumatic piercing tool
 - 4.4.3 Horizontal directional drilling
 - 4.4.4 Auger Boring
- 4.5 Follow proper depth and clearance requirements as outlined in [MAIN 1](#) and [SERV 1](#). Refer to 49 CFR §§ 192.325 Underground clearance and 192.361 Service line installation.

5.0 Boring Site Evaluation

- 5.1 The following questions shall be answered by visually inspecting the boring site for suitability by walking the area:
 - 5.1.1 Is there sufficient room at the site for entrance and exit pits, support vehicles, fusion machines and stringing out the pipe to be pulled in?
 - 5.1.2 Is there sufficient set-up room to obtain the desired depth and angle of bore, prior to the bore head reaching the feature which it is to bore under?
 - 5.1.3 Is there evidence of substructures such as?
 1. Manhole covers
 2. Valve box covers
 3. Meter boxes
 4. Telephone and cable television boxes
 5. Electrical transformers
 6. Conduit
 7. Drop lines from utility poles
 8. Pavement patches
 9. Previous locator markers
 10. Cisterns
 11. Septic tanks and leach field piping
 12. Sewer lateral cleanouts
 - 5.1.4 Are there the following, which could affect calibration or operation of boring equipment and instruments?

1. Overhead cable TV, power, telephone lines
2. Fiber-trace lines
3. Chain link fences
4. Metal structures
5. Reinforce concrete
6. Traffic signal loops
7. Cathodic protection
8. Water
9. Cell phones
10. Other sources.

5.1.5 Is there the need for traffic control and/or flagmen if close to street, road or highway?

5.2 Mark out proposed work location prior to calling JULIE (Joint Utility Locating Information for Excavators), the "One-Call" program.

5.3 Plan the drill path that:

5.3.1 Is straight as possible to minimize friction when pulling back.

AND

5.3.2 Minimizes restoration costs.

5.4 Determine the extent of the area where Ameren Illinois has the right to access the area for installation and maintenance of gas facilities

6.0 Bore Site Preparation

6.1 Notify land owners that they need to locate and mark their buried facilities when applicable. Some examples are:

6.1.1 Buried roof drain lines

6.1.2 Buried customer owned gas and/or electric line(s)

6.1.3 Sanitary/septic system including drain tiles, leach fields, and tanks

6.1.4 Potable water wells and private water line

6.1.5 Sprinkling system piping

6.1.6 Invisible fence cable

6.2 Determine the proposed drill path, including its proposed depth, and the location and depth of all substructures along the path.

The drill path should be as straight as possible to minimize the frictional resistance during pull back and to maximize the length of pipe that can be installed in a single pull.

6.3 Horizontal directional drilling paths shall follow equipment manufacturer's recommended horizontal and vertical angle of curvature.

- 6.4 Establish locations for all entrance and exit pits.
- 6.5 For horizontal directional drilling operation:
 - 6.5.1 Exit and entrance pit areas should be of sufficient size to contain the drilling mud, if used, and spoils.
 - 6.5.2 Take precautions to keep drilling fluids out of the sewers, and other drainage systems, including streams and river by doing one or all of the following:
 - 1. Dig a small retention pit.
 - 2. Build a berm to control the fluid.
 - 3. Block off the sewer inlets or catch basins with sand bags.
 - 4. Use an inflatable pit for catching and holding fluids.
 - 6.5.3 A contingency clean-up plan shall be developed.

End of Instructions.

Operator Qualification (OQ) Required?

NO.

Appendices

NONE.

Attachments

NONE.

Compliance Requirements

49 CFR §192.325 Underground clearance.

49 CFR §192.361 Service lines: Installation.

Reference Documents

[MAIN 1 Main Installation: Requirements](#)

[SERV 1 Service Line Installation: Requirements](#)

Document Rescission

BORE 1 Boring: Requirements, January 1, 2018.

BORE 2.01 Boring: Boring Location Criteria, January 1, 2018.

Revision Notes

Location of Changes	Summary of Changes
Not applicable.	This is a new document.

BORING

April 1, 2023

BORE 2.1 Boring Operations and Pipe Installation

1.0 Purpose

This document provides information for boring operations and pipe installation in the bore, in accordance with minimum requirements of 49 CFR §§ 192.325, 192.327, 192.329, and 192.376.

2.0 Scope

This document addresses the following:

[3.0 Target Audience](#)

[4.0 Boring Operations](#)

[5.0 Conventional Rod Boring](#)

[6.0 Pneumatic Piercing Tool Boring](#)

[7.0 Directional Drilling](#)

[8.0 Auger Boring and Jack & Bore Method](#)

[9.0 Pipe Installations](#)

3.0 Target Audience

- Gas Engineering
- Gas Distribution Design Specialists
- Gas Construction Personnel
- Gas Supervisors
- Gas Construction Services Personnel

4.0 Boring Operations

4.1 General

4.1.1 Directional bore personnel include:

1. Machine operators
2. Locators, working in the vicinity of the bore path from the machine to the bore head.
3. Gas personnel, working in the vicinity of the bore path from the machine to the bore head

4.1.2 Pipe installed by any boring method shall comply with the depth and clearance requirements contained in [MAIN 1](#) and [SERV 1](#). (49 CFR §§ 192.325, 192.327, 192.329, and 192.376)

4.2 Boring Safety

4.2.1 Follow the safety guidelines specified in this document.

4.2.2 To protect all workers in the area, gas field personnel must:

UNCONTROLLED IF PRINTED

1. Know what procedures the boring operator is trained to follow.
2. Apply safe work practices at the excavation site. See [EXCV 2.3](#) Work in Excavation.
3. Ensure excavations are in accordance with OSHA Standards before entering. See [EXCV 1](#) Requirements.
4. Wear the appropriate PPE.
5. Clothing should be snug fitting and in good shape.

Loose fitting clothing, long hair, and tattered clothing can get caught in the rotating rods, resulting in serious personal injury.

4.2.3 Since boring operations may encounter an energized electric cable which could energize the boring machine, the following safety precautions should be followed:

1. The area around the boring machine should be marked to warn persons of the potential electrical hazard. The following, but not limited to, items can be used to mark the area:
 - 1 a. Cones
 - 1 b. Tape
 - 1 c. Barricades
2. Other than the boring machine operator, no one should touch the machine during the boring operations.
3. Directional boring units shall be grounded in accordance with manufacturer's instructions.
4. Boring machine operators shall remain in the operator's seat, where applicable, and not allow any part of their body to contact the ground while the boring machine is in operation.
5. All personnel working in the vicinity of the boring operations, who may be exposed to subsurface electrical hazards, shall wear boots meeting the most current edition of ASTM Standards F2412 and F2413 Electrical Hazard (EH) rating. **During work in muddy or wet conditions, rubber insulated EH-rated boots (either over-boots or safety-toed boots) shall be worn.**

4.2.4 Gas field personnel shall use a guide rod hook to align rotating boring rods.

Never straddle or stand-on the boring rods while they are rotating.

No one shall be in the excavation or ditch while boring equipment is in operation.

Gas field personnel are allowed in the excavation for the purpose of aligning the pneumatic piercing tool and getting it started.

4.2.5 Keep unauthorized personnel away from the work area.

4.3 Prior to Beginning Operations

4.3.1 Ensure proper job site protection and required traffic control is in place.

4.3.2 All marked buried facilities crossing the proposed bore path or that are within the tolerance zone shall be exposed in accordance with [the Subsurface Utility Protection section of the](#) AIC Field Safety Manual.

4.3.3 Potholes shall:

1. Extend eighteen (18) inches on either side of the locator's marks
and
2. Be of such depth to ensure the buried facilities will not be damaged by boring and back reaming operations and that there is sufficient clearance as stated in [MAIN 1 Paragraph 10.2.1](#) and [SERV 1 Section 6.0](#) Underground Clearances.

4.3.4 Verify the depth of water lines and gravity sewers, under hard surfaces, such as state highways, driveways, etc., by checking water line valve boxes and sewer manholes, where it may be hazardous or infeasible to expose facilities prior to boring.

1. If the depth of an underground facility cannot be verified to be clear of the proposed bore path, then the Ameren Damage Prevention team should be contacted in order to determine a course of action which best limits risk and is in compliance with JULIE requirements.
2. The facility shall be uncovered, at a minimum, on each side of the hard surface before boring begins.

4.3.5 If sewer line, main or laterals, are not exposed or their depth are not verified, Gas Field Personnel shall refer to [BORE 2.2](#), Boring Across or Near Sewer Lines, for available options.

4.3.6 When necessary, measures to avoid interference from overhead electrical, telephone and cable lines should be made.

4.3.7 Determine who will be communicating with the boring machine operator during the actual boring operation and the means of communicating:

1. Hand signals
or
2. Radio.

4.3.8 Gas Supervisor, crew leader, or foreman shall conduct an in-depth job briefing covering all of the subjects on the Job Briefing Form with entire crew.

5.0 Conventional Rod Boring

5.1 Establish location for the entrance and exit excavation.

UNCONTROLLED IF PRINTED

Entrance and exit excavation must be long enough and deep enough for gas field personnel to position the rod boring equipment at the appropriate depth and angle of entry.

- 5.2 Equipment with the boring motor should be positioned in-line with the projected bore path.
- 5.3 Inspect the drill rods for damaged:
 - 5.3.1 Connector ends
 - 5.3.2 Cracks
 - 5.3.3 Bent rods.
- 5.4 Assemble rods with no more than two (2) rods, approximately 10 feet each, exposed outside of entrance pit at one time.
- 5.5 Machine operator should monitor the boring rate and investigate any obstruction to determine if it might be hazardous.
- 5.6 Machine operator should control the machine travel speed so as not to put the bore rods under undue stress or strain.

Boring rate should be slow and steady.

- 5.6.1 Pipe locator can be connected to bore rods to determine approximate location of drill head and possible obstructions, when required. Refer to [LOCT 1](#).

Do not attempt to attach locator to the rods until they are no longer rotating and drive motor is disengaged.

- 5.6.2 Workers shall observe potholes as the drill head, back reamer and rods cross, when potholes have been excavated to expose other underground facilities and the proposed bore path, to ensure the facility has not been damaged and to check the depth of the bore.
 - 1. If drill head and rods are not visible in potholes a determination shall be made if the drill path is in proper alignment or at the proper depth. Refer to [Section 4.3.3](#) for information on depth of pothole.
- 5.6.3 Machine operator shall shut off the boring machine motor while the:
 - 1. Drill bit is being removed
and
 - 2. Back reamer installed

6.0 Pneumatic Piercing Tool Boring

- 6.1 Establish location for the entrance and exit excavation.

UNCONTROLLED IF PRINTED

Entrance and exit excavation shall be long enough and deep enough for gas field personnel to position the pneumatic piercing tool at the appropriate depth and angle of entry.

- 6.2 Select the proper size of pneumatic piercing tool for the pipe size being installed.
- 6.3 Gas field personnel shall inspect the following to ensure they are in good condition:
 - 6.3.1 The piercing tool.
 - 6.3.2 The tool's tail hose.
 - 6.3.3 Control valve.
 - 6.3.4 Air hose and air hose connectors.
- 6.4 Air hose connections shall be secured by positive means to prevent accidental disconnection with one of the following:
 - 6.4.1 Thor self-locking connectors. See Figure 1.



Figure 1. Thor self-locking connector

- 6.4.2 Chicago fitting connectors with safety clip provide secured connections. See Figure 2.



Figure 2. Chicago fitting connector

- 6.5 After assembly, the piercing tool shall be placed in the excavation and test run made to ensure the forward and reverse control is functioning properly.
- 6.6 The tail hose should be marked to provide workers with indication of the tool's progress. Based on the mark, if the piercing tool has not entered the exit excavation this may be an indication the tool has either taken:
 - 6.6.1 A nose dive.

or

UNCONTROLLED IF PRINTED

- 6.6.2 Has gone deeper than the exit excavation
or
- 6.6.3 Has drifted to one side or the other.
- 6.7 Dig out a starter hole in the end of the entrance excavation where the nose of the piercing tool can be inserted.
- 6.8 Worker(s) shall support the piercing tool at the angle of the planned bore path.
- 6.9 The worker operating the control valve will turn on the air to the tool allowing the tool to begin hammering its way into the bank.
- 6.10 The worker(s) supporting the tool shall leave the excavation once the tool has advanced far enough along the bore path that it has become stable.
- 6.11 A worker should check on the progress of the piercing tool on a regular basis.

Based on the observations, the operation may need to be halted, the tool backed out and repositioned.

- 6.12 Worker(s) shall shut off the air to the piercing tool when it enters the exit excavation.

7.0 Directional Drilling

- 7.1 Establish a location for the entrance and exit excavation.

As a rule of thumb, the entrance angle of the bore rod should normally be between 8 degrees and 18 degrees. However, conditions may warrant a steeper angle as long as it does not exceed minimum bending radius of the rod or pipe. A minimum of one complete length of drill rod (ten (10) feet for smaller rigs and thirty (30) feet for larger rigs) should be utilized before leveling out to the appropriate depth.

- 7.2 Entrance and exit pits shall be of sufficient size to contain the drilling mud, if used, and spoils.
- 7.3 Check that the specified burial depths comply with regulations or permits.
- 7.4 Ensure that:
 - 7.4.1 Drilling equipment size is adequate for the job, including pilot hole boring and pipe pull back.
 - 7.4.2 An adequate supply of water and additives (e.g., bentonite) for preparation of drilling fluids is available if needed.

The required amount and viscosity of the drilling mud will be a function of soil conditions, drilling rate, cutting and hole size, pump capacity, etc.

Because there can be possible soil condition changes along the drill path, it may be necessary to alter the drilling fluid viscosity during the drilling operation.

- 7.5 Drilling muds or liquid additives shall be used during drilling and back reaming when soil conditions require it.
- 7.6 A filter shall be used with the drill pump to prevent clogging of the drill head jets.

In some cases, improved performance and operation can be achieved simply by removing one or more of the jets from the drilling head to allow free flow of the mud. Removing jets also can minimize clogging problems.

- 7.7 Begin boring by drilling the pilot hole; **mark the bore head progression with spray paint.**
- 7.8 Drilling shall proceed downhill whenever possible to ensure that the drill mud remains in the hole.
- 7.9 Workers shall observe potholes as the drill head, back reamer and rods cross to ensure the facility has not been damaged and to check the depth of the bore, where potholes have been excavated to expose other underground facilities and the proposed bore path.
 - 7.9.1 If drill head and rods are not visible in potholes, a determination shall be made if the drill path is in proper alignment or at the proper depth. Refer to [Section 4.3](#) Prior to Beginning Operations for information regarding depth of pothole.
- 7.10 Cease drilling operations if an unidentifiable or unanticipated resistance or sudden movement of the drill string is encountered.
 - 7.10.1 Proceed only after the disturbance source has been identified and/ or eliminated.
- 7.11 If a substructure is damaged, notify the appropriate utility or owner immediately.
- 7.12 The hole shall be back reamed, if the pilot bore-hole bit does not provide a bore hole that is approximately 1.5 times the pipe nominal diameter or greater, to accommodate and permit free sliding of the pipe into the bore-hole.
- 7.13 The diameter of the back-reamed hole should typically be greater than 1.5 times the nominal diameter of the pipe. Refer to [Table 1](#).

The terms and conditions listed in a required boring permit may limit the back-reamer size.

For large diameter pipe such as 6 inch and greater, pulling back a series of progressively larger reamers may be needed prior to beginning pullback operations.

Table 1

Recommended Back-ream Diameters for Different Pipe Sizes

Nominal Pipe Diameter (in.)	Back-ream Hole Diameter (in.)
1 or less	1.5 to 2
2	3 to 4
3	4.5 to 6
4	6 to 8
6	9 to 12
8	12 to 14
10 and greater	Minimum 6 inches greater than pipe OD

7.14 Dispose excess drilling mud in compliance with local ordinances, regulations, and environmentally sound practices.

Spoils and drilling fluids are not permitted to be disposed of into sewers (storm or sanitary) or other drainage systems including streams and rivers.

8.0 Auger Boring and Jack & Bore Method

8.1 These operations are done by a contractor. Review contractor's procedures for conformance with AIC safety standards.

9.0 Pipe Installation

9.1 General

9.1.1 Installing pipe shall be planned so that back-reaming and pull in for a leg can be completed on the same day.

9.1.2 Pipe installation shall be performed in a manner that minimizes:

1. Over stressing/straining the pipe
and
2. Damage to the pipe coating/surface.

9.1.3 See [MAIN](#), [STLP](#), and [POLY](#) sections of the O&M Plan for additional installation requirements.

9.1.4 The line shall be pressure tested to company standards after installation. Refer to [PTST 1](#).

9.1.5 Completed pipe installations shall be back flagged in accordance with [DAMG 1 Section 11.0 Back Flagging](#).

9.2 PE Pipe

9.2.1 The tracer wire may be attached to the leading end of the PE pipe or to the pulling head and pulled in with the pipe.

Electrical continuity of the tracer wire is essential for PE pipe installation and, therefore, it should be free of splices if at all possible.

When installing gas main or service lines under streets, highways, streams, creeks or any area that would be difficult to access should the tracer wire break, pulling back two tracer wires should be considered and is strongly encouraged. The wire ends should be connected.

- 9.2.2 Consideration should also be given to using stainless steel tracer wire for long and/or difficult directional bores or plow-ins. See [POLY 1](#) for stock codes.
- 9.2.3 A swivel shall be attached to the reamer, or drill rod, to prevent rotational torque being transferred to the pipe during pull-in.
- 9.2.4 A weak link or breakaway device shall be attached between the swivel and the leading end of PE pipe to prevent over stressing PE pipe. Refer to [POLY 2.3](#) for weak link requirements.
- 9.2.5 If the breakaway device is a swivel it can be connected to the leading end of the PE pipe.

AIC document [POLY 2.3](#) "Polyethylene Pipe: Installation Requirements", has tables which list the maximum tensile loads for MDPE and HDPE pipe along with corresponding mechanical weak links that have a breaking load less than the maximum tensile load for each pipe size.

- 9.2.6 The leading pipe end shall be capped or plugged to prevent water, drilling fluids and other foreign materials from entering the pipe as it is being pulled back.
- 9.2.7 The following should be used to protect the pipe being pulled:
1. Pipe rollers, skates or other protective devices or means to prevent damaging pipe from the edges of the pit or substructures during pull-in.
 2. Rollers under sticks of pipes to protect the pipe from gouges, eliminate ground drag, and reduce the pull-in force.

Use of scrap pipe for rollers is acceptable.

- 9.2.8 Gas field personnel shall check the pipe for the following that would impair the serviceability of the PE pipe:
1. Damage to the pipe surface
 2. Gouges

3. Cuts
 4. Scrapes
- 9.2.9 Gas field personnel shall inspect the PE pipe as it is being pulled-in to ensure pipe surface is not being damaged.
1. If damage is observed, gas field personnel should stop the installation process.
 2. Damage shall be evaluated as per the procedure outlined in [POLY 2.7](#) Polyethylene Pipe: Evaluating PE Pipe Damage.
 3. Damaged pipe shall be repaired or replaced before resuming installation. Refer to [REPR 1](#) Repairs: Requirement.
- 9.2.10 Additional length of pipe shall be pulled back through the entrance pit, exposed, cleaned and examined for scratches, scores, gouges, cuts, damaged coating and other forms of damage.
1. If damage has occurred additional investigation is required to determine extent of damage.
- 9.2.11 Line Tamer should be used on 4-inch and larger coiled pipe, when necessary. See Figure 3 for a photo of a Line Tamer.

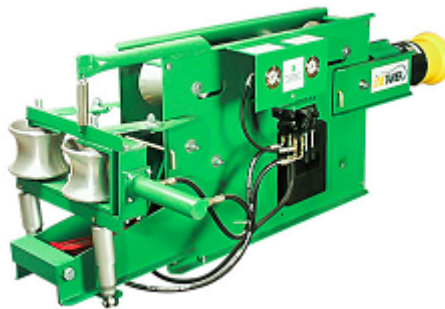

Figure 3. LineTamer

- 9.2.12 Observe the bore head, back reamer and leading end of pipe as they pass through the potholes to ensure adequate clearance between the pipe and other buried facilities. See [Section 4.3](#) for pothole depth requirements.

9.3 Steel Pipe

- 9.3.1 Steel pipe coating shall meet requirements contained in [CORR 2.3](#), Coatings, and inspected in accordance with [CORR 2.3](#) Coatings, before being pulled into bore hole.
- 9.3.2 Weld joints shall be coated in accordance with [CORR 2.3](#) Coatings.
- 9.3.3 When pulling steel pipe back through the borehole care shall be taken not to damage the coating.
- 9.3.4 Additional length of pipe shall be pulled back through the entrance pit, exposed, cleaned and examined for scratches, scores, gouges, cuts, damaged coating and other forms of damage.
1. If damage has occurred additional investigation is required to determine extent of damage.

2. Depending on the nature of damage, contact Gas Tech Engineering and/or Corrosion Control personnel to determine extent of investigation, procedures to be utilized and required repairs if needed. See [CORR 2.3](#) for coating repairs.
- 9.3.5 Observe the bore head, back reamer and leading end of pipe as they pass through the potholes to ensure adequate clearance between the pipe and other buried facilities. See [Subsection 4.3](#) for pothole depth requirements.

End of Instructions

Operator Qualification (OQ) Required?

YES

- 0301: Manually Opening and Closing Valves
- 0561: Pressure Test - Nonliquid Medium - MAOP Less than 100 psi.
- 0571: Pressure Test - Nonliquid Medium - MAOP Greater than or Equal to 100 psi
- 0721: Joining of Pipe - Threaded Joints
- 0751: Joining of Plastic Pipe - Butt Heat Fusion: Manual
- 0761: Joining of Plastic Pipe - Butt Heat Fusion: Hydraulic Machine
- 0781: Joining of Plastic Pipe - Electrofusion
- 0801: Welding
- 0811: Visual Inspection of Welding and Welds
- 0871: Installation of Steel Pipe in a Bore
- 0891: Field bending of Steel Pipe
- 0911: Installation of Plastic Pipe in a Bore
- 0941: Install Tracer Wire
- 0981: Backfilling
- 0991: Coating Application and Repair - Brushed or Rolled
- 1001: Coating Application and Repair - Sprayed
- 1011: External Coating Application and Repair - Wrapped
- 1291: Locate Underground Pipelines
- A001: Service Reconnect
- A003: Emergency Response

Appendices

NONE

Attachments

NONE

Compliance Requirements

UNCONTROLLED IF PRINTED

49 CFR §192.325 Underground clearance.

49 CFR §192.327 Cover.

49 CFR §192.329 Installation of plastic pipelines by trenchless excavation.

49 CFR §192.376 Installation of plastic service lines by trenchless excavation.

ASTM Standards F2412 and F2413 Electrical Hazard (EH) rating

Reference Documents

[BORE 2.2 Boring: Boring Across or Near Sewer Lines](#)

[CORR 2.3 Corrosion Control: Coatings](#)

[EXCV 1 Excavation Safety: Requirements](#)

[EXCV 2.3 Excavation Safety: Work in Excavation](#)

[LOCT 1 Locating: Methods](#)

[MAIN Main Installation](#)

[MAIN 1 Main Installation: Requirements](#)

[POLY Polyethylene Pipe](#)

[POLY 1 Polyethylene Pipe: Requirements](#)

[POLY 2.7 Polyethylene Pipe: Evaluating PE Pipe Damage](#)

[PTST 1 Pressure Testing: Requirements](#)

[REPR 1 Repairs: Requirements](#)

[SERV 1 Service Line Installation: Requirements](#)

[STLP Steel Pipe](#)

AIC Field Safety Manual, Section 33.4 Work Within the Tolerance Zone

Document Rescission

BORE 2.1 Boring – Boring Operations and Pipe Installation, May 15, 2022

Revision Notes

Location of Changes	Summary of Changes
Paragraph 4.2.3 – Item 5	Revised - All personnel working in the vicinity of the boring operations, who may be exposed to subsurface electrical hazards, shall wear boots meeting the most current edition of ASTM Standards F2412 and F2413 Electrical Hazard (EH) rating. During work in muddy or wet conditions, rubber insulated EH-rated boots (either over-boots or safety-toed boots) shall be worn
Paragraph 4.3.2	Revised – the tolerance zone shall be exposed in accordance with the Subsurface Utility Protection section of the AIC Field Safety Manual

UNCONTROLLED IF PRINTED

Subsection 7.7 Directional Boring	Revised – Begin boring by drilling the pilot hole, mark the bore head progression with spray paint.
Subsection 7.13	Added NOTE: The terms and conditions listed in a required boring permit may limit the back-reamer size.

BORE 2.2 Boring Across or Near Sewer Lines

1.0 Purpose

This document provides information for boring across or near sewer lines in accordance with minimum requirements of 49 CFR §192.325.

2.0 Scope

This document addresses the following:

[3.0 Target Audience](#)

[4.0 General Requirements](#)

[5.0 Pre-Construction Steps](#)

[6.0 Camera Inspection of High-Risk Sewer Laterals](#)

[7.0 Construction Steps](#)

[8.0 Sewer Cleaning Notification](#)

[9.0 Response to Inquiries](#)

Appendices

[Appendix A - Typical Sewer Installations](#)

[Appendix B - Sample Door Tag](#)

[Appendix C - Sample Cross Bore Brochure](#)

3.0 Target Audience

- Gas Engineering
- Gas Distribution Design Specialists
- Gas Construction Personnel
- Gas Supervisors
- Gas Construction Services Personnel

4.0 General Requirements

The operation of various trenchless technologies in close proximity to sewer lines must be done cautiously to avoid installing a gas line through a sewer line or sewer lateral.

- 4.1 Pre-construction and construction steps must be taken to identify the location of sewer lines or sewer laterals that are within the proposed bore path. Refer to [BORE 2.1 Section 4.3](#).

5.0 Pre-Construction Steps

5.1 The following pre-construction steps should be used to determine if sewer lines are located in the proposed construction area:

5.1.1 Contact the:

1. City
2. Building owners
3. Local plumbers
4. Other persons that can provide assistance with identifying the existence and location of sewer lines.

5.1.2 Obtain maps and drawings of the sewer system from the city or other entity.

Maps can provide location and approximate original installation depth of the sewer lines and other valuable information that can assist in determining if location of the sewer lines is within the proposed bore path.

5.1.3 Visually check the job site for:

1. Sewer cleanouts
2. Manhole covers
3. High-risk sewer laterals.
4. Indication of forced sewer.

5.2 Once it has been determined that sewer lines are located in the proposed construction area the following steps are required to identify the location and depth of the sewer lines:

5.2.1 If location of the line is known, excavate sufficient depth below the proposed bore path to verify the sewer line is deep enough that it will not be damaged by the drill head and/or back reamer. Refer to [MAIN 1 Section 10](#) and [SERV 1 Section 6.0](#) for minimum clearances.

5.2.2 Access available outside or inside clean-outs and measure the depth of the sewer line lateral.

Use of steel sewer tape or similar item and a pipe locator may assist in determining location of sewer lateral.

Sewer lateral may not have a consistent grade from the building to the sewer line affecting the assumptions of the sewer lateral depth.

5.2.3 Workers shall avoid direct contact with contents of the sewer line by using rubber/neoprene gloves, protective eye wear, and coveralls.

Unprotected contact with sewer line contents may present a health hazard.

- 5.2.4 Access any manhole covers and measure approximate depth to the top of the main sewer line.

On gravity flow sewer mains, it is reasonable to assume sewer line has a constant grade between manholes. The depth to the top of pipe below the surface can be determined based on that fact. **The same is not true of forced sewer system.**

- 5.2.5 If possible, obtain access to all buildings that do not have an outside clean-out and visually identify where the sewer exits the structure.

1. Determine approximate depth of the sewer lateral by identifying where the lateral exits the building versus the depth of the sewer main at the street.
2. Drawings that represent typical sewer line installations can be found at the end of this section to assist with identifying high risk installations. See [Appendix A Typical Sewer Installations](#).

- 5.2.6 The use of camera inspection for high risk sewer lateral is required unless sewer lateral is located and exposed prior to construction. See [Section 6.0](#) Camera Inspection of High-Risk Sewer Laterals.

- 5.2.7 If the estimated depth of the sewer lateral indicates a potential conflict, the location and depth of the sewer laterals shall be verified by exposing the lateral in accordance with [BORE 2.1 Subsection 4.3](#) or excavating a sufficient depth below the proposed bore path to ensure the lateral will not be damaged by the drill head and/or back reamer.

- 5.3 Forced sewer system mains and laterals shall be:

- 5.3.1 Physically exposed

or

- 5.3.2 Excavate pot holes in accordance with BORE 2.1 Subsection 4.3 to a sufficient depth below the proposed bore path to ensure the sewer line will not be damaged by the drill head and/or back reamer.

- 5.4 If the pre-construction steps do not positively identify the location of sewer lines and laterals, the following options are available:

- 5.4.1 Do not use boring or other trenchless equipment for installing the gas main or service.

- 5.4.2 Use the boring equipment and perform a post-construction camera inspection of high-risk sewer lines.

- 5.4.3 Use "sewer listening device" as described below in [Section 7.0](#).

- 5.4.4 Use boring equipment only in those areas where the location and depth of sewer lines have been determined to be safely outside the bore path.

UNCONTROLLED IF PRINTED

- 5.4.5 Use open trench equipment for areas where the sewer line conflicts have not been ruled out.

6.0 Camera Inspection of High-Risk Sewer Laterals

- 6.1 Camera inspection of sewer lines applies to new construction and replacement projects.
- 6.2 High risk sewer lateral is defined as a sewer lateral that is within two (2) feet of the proposed gas facility.
- 6.3 High risk sewer laterals that are not located and exposed prior to construction shall be inspected by camera pre and/or post installation of the gas facility.
- 6.4 Examples of high-risk sewer laterals are shown in [Appendix A](#) Typical Sewer Installations.

7.0 Construction Steps

- 7.1 Before boring, conduct a final inspection along the proposed drill path looking for:
 - 7.1.1 Unmarked sewer facilities
 - 7.1.2 Verification that the depth to the marked sewer lines are not in conflict with proposed bore path.
- 7.2 Every effort should be made to maintain the clearances shown in [MAIN 1 Section 10.0](#) or [SERV 1 Section 6.0](#) between the gas line and the sewer line.
- 7.3 Stop all boring operations if resistance or sudden movement of the boring equipment is encountered.
- 7.4 Particular care should be taken to ensure that a sewer line or lateral is not the cause of the resistance or sudden movement.
- 7.5 Continue with boring operation only after the source of the resistance or sudden movement has been identified and/or eliminated.
- 7.6 A "sewer listening device" shall be used during all boring operations where sewer lines are not physically exposed or the depth of the sewer line has not been verified to be clear of the bore path. See [BORE 3](#) Forms and Reference Materials for instruction manuals.

Field testing of these sewer listening devices has proven they will detect a bore penetration; however, the penetration noise may only be detected for a short duration if the drill bit passes through the sewer.

The ability to hear a penetration can be affected by surrounding traffic noise.

- 7.6.1 The person monitoring the sewer for a penetration shall be alert to any unusual noise and immediately communicate this information to the equipment operator.

It is possible that the bore penetration of a sewer will coincide with a resistance felt by the operator.

- 7.7 Hang a "Boring Equipment Used on Nearby Gas Main" door tag, Stock Code 37 22 236, at each home or business where or in the area where boring operations were conducted. See [Appendix B](#) for sample of door tag.

The door tag will provide resident with an Ameren Illinois phone number, 1-800-755-5000, to call if they experience a sewer problem. Resident is instructed to call Ameren Illinois before calling a sewer repair contractor.

The door tag will advise the occupants of the home or business of the recent boring operation and alert them that a bore can enter a sewer line on some rare occasions and cause a sewer problem.

- 7.8 A camera shall be used for inspection of a high risk sewer lateral, unless sewer lateral is located and exposed prior to construction. See [Section 6.0](#) Camera Inspection of High Risk Laterals.

8.0 Sewer Cleaning Notification

- 8.1 An informational Ameren Cross bore Brochure, Caution: Natural Gas and Electric Lines May Unintentionally Intersect Sewer Line (See [Appendix C](#) for a sample of the cross bore brochure), is sent annually to the following where Ameren Illinois conducts boring operations:

- 8.1.1 Local plumbers
- 8.1.2 City sewer departments
- 8.1.3 Operators of sewer cleaning businesses.

The brochure will notify them that a bore, for the installation of a gas or electric line, can enter a sewer line on some rare occasions, potentially causing a sewer problem.

- 8.2 When extensive boring operations are being conducted in a town, an additional letter which includes general location(s) of the boring activity, shall be sent before the project begins to:

- 8.2.1 Local plumbers
- 8.2.2 City sewer department
- 8.2.3 Operators of sewer cleaning businesses

9.0 Response to Inquiries

- 9.1 Ameren Illinois may receive an inquiry from a plumber, an operator of a sewer cleaning business, or an individual that suspects a gas line may be installed in a sewer line.
 - 9.1.1 When this occurs, the Gas Supervisor shall arrange a meeting for the purpose of identifying if a gas line is installed in a sewer line.
 - 9.1.2 The gas line may be newly installed or it could have been installed in previous years; therefore, the inquiry shall not be dismissed.

End of Instructions.

Operator Qualification (OQ) Required?

YES.

1291: Locate Underground Pipelines

A003: Emergency Response

Appendices

[Appendix A - Typical Sewer Installations](#)

[Appendix B - Sample Door Tag](#)

[Appendix C - Sample Cross Bore Brochure](#)

Attachments

NONE.

Compliance Requirements

49 CFR §192.325 Underground clearance.

Refer to referenced AIC documents.

Reference Documents

[BORE 2.1 Boring: Boring Operations and Pipe Installation](#)

[MAIN 1 Main Installation: Requirements](#)

[SERV 1 Service Line Installation: Requirements](#)

Document Rescission

BORE 2.2 Boring Across or Near Sewer Lines, December 1, 2020

Revision Notes

Location of Changes	Summary of Changes
Subsection 5.1	Should replaces shall

End of Section.

Appendix A - Typical Sewer Installations

A-1. Typical Sewer Installation - Level lot home with a basement

Typical Sewer Installation

Level lot

Home with basement

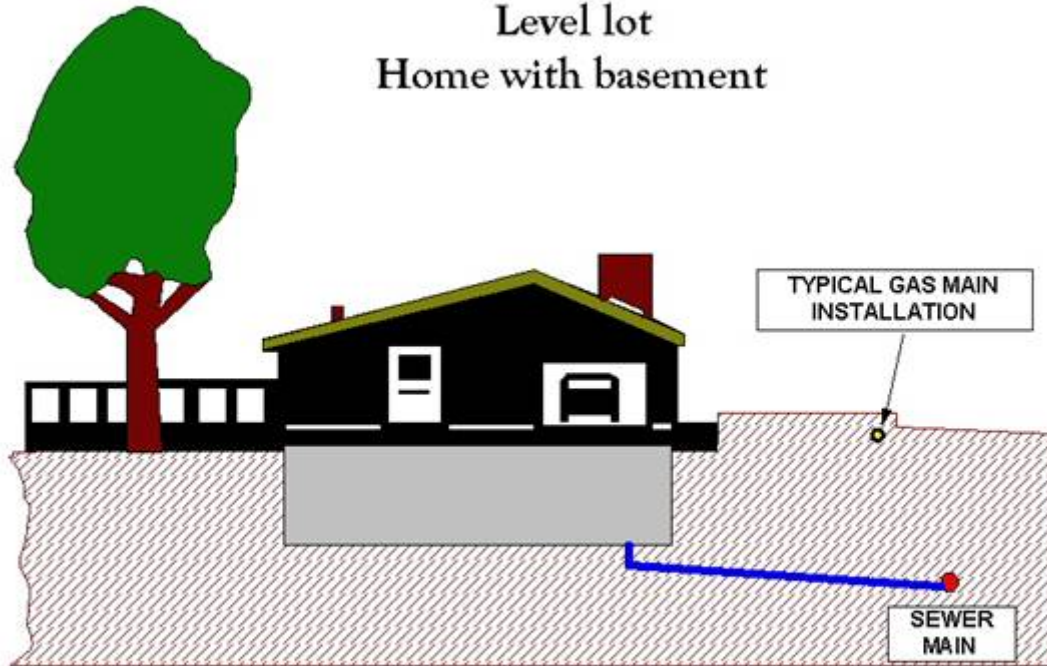

© 2011 BORE 2.2 Boring Across or Near Sewer Lines
Rev. 05/12

Level Lot - Home with Basement

1. A visual inspection of the basement would show that the sewer exits through the floor at a depth significantly greater than a typical gas main would be installed.
2. A sewer line installation as pictured below would not have to be physically located before boring.
3. This is not considered a High Risk Sewer Lateral.

A-2. Elevated Lot - Outside Cleanout

UNCONTROLLED IF PRINTED

Typical Sewer Installation Elevated Lot Outside cleanout

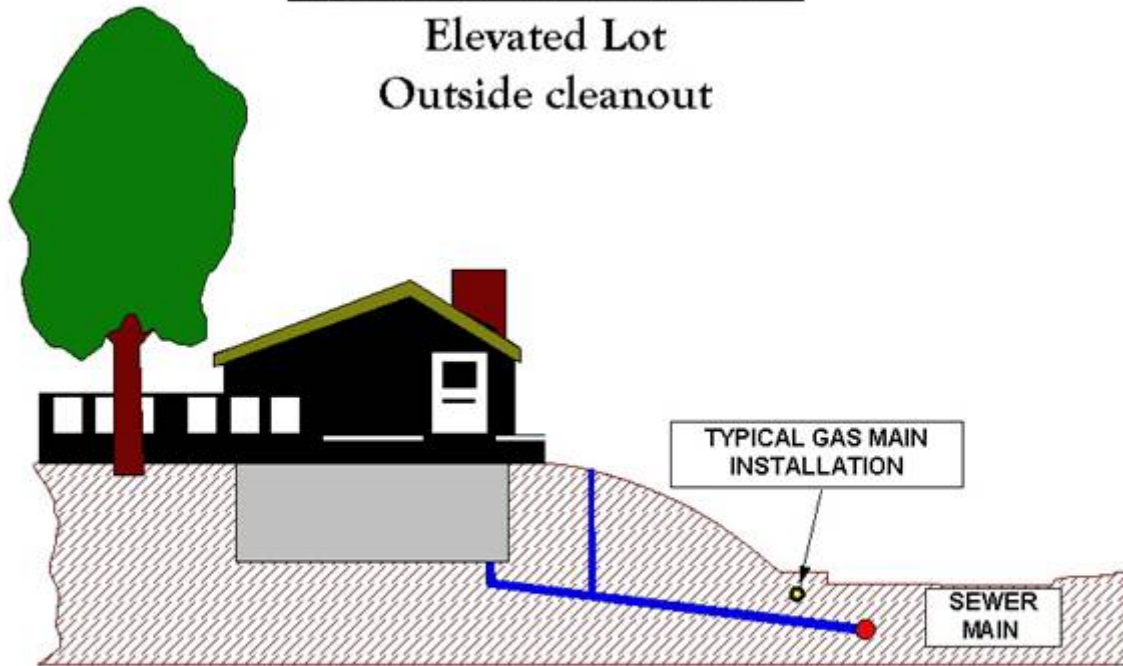

2200017 05/14/2013 02:40
Rev. 5502

Elevated Lot - Outside Cleanout

1. A visual inspection of the basement or a depth measurement at the clean out would show that the sewer near the home is at a depth significantly greater than a typical gas main would be installed.
2. However, since the home is built on an elevated lot, there is the potential for conflict with boring operations.
3. This is considered a "High Risk Sewer Lateral" if the sewer lateral can't be located and exposed.

A-3. Original Sewer Abandoned - New Sewer Connected into Old Sewer at Curb

UNCONTROLLED IF PRINTED

Typical Sewer Installation
Original sewer abandoned
New sewer connected into old sewer at curb

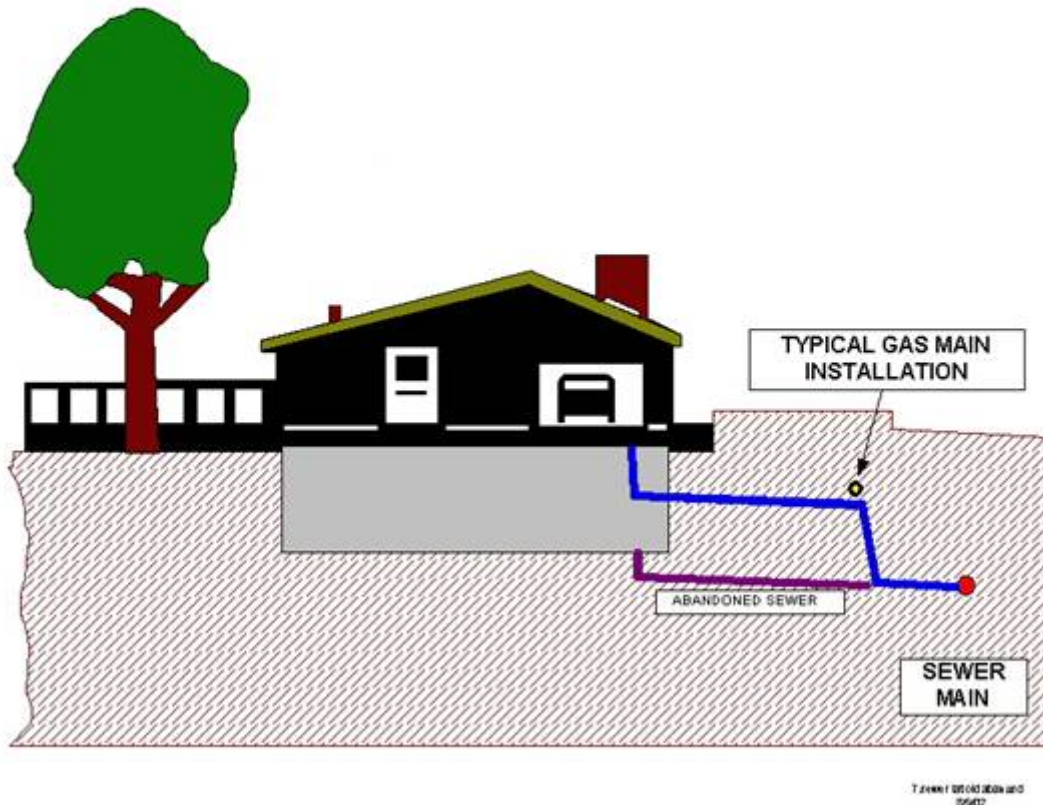

Original Sewer Abandoned - New Sewer Connected into Old Sewer at Curb

1. A visual inspection of the basement would show that the sewer exits the sidewall at a depth of a typical gas main installation.
2. This is considered a "High Risk Sewer Lateral" if the sewer lateral can't be located and exposed.

A-4. Very Elevated Lot

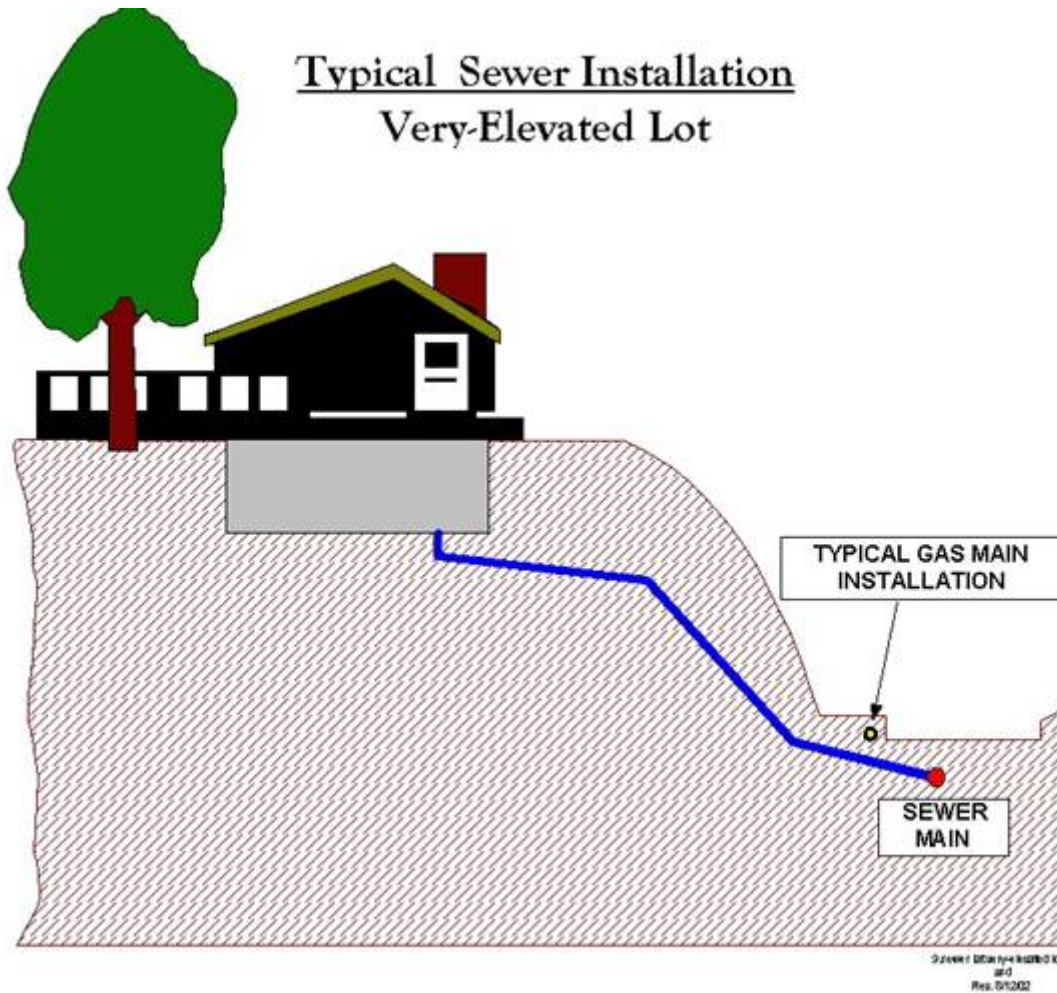

Very Elevated Lot

1. A visual inspection of the basement would show that the sewer near the home is at a depth significantly greater than a typical gas main installation.
2. However, since the home is built on an elevated lot, there is the potential for conflict with boring operations.
3. This is considered a "High Risk Sewer Lateral" if the sewer lateral can't be located and exposed.

A-5. Home with Basement - Sewer Lift Pump Required

Typical Sewer Installation
Home with basement
Main sewer depth would not allow floor installation
Lift pump required

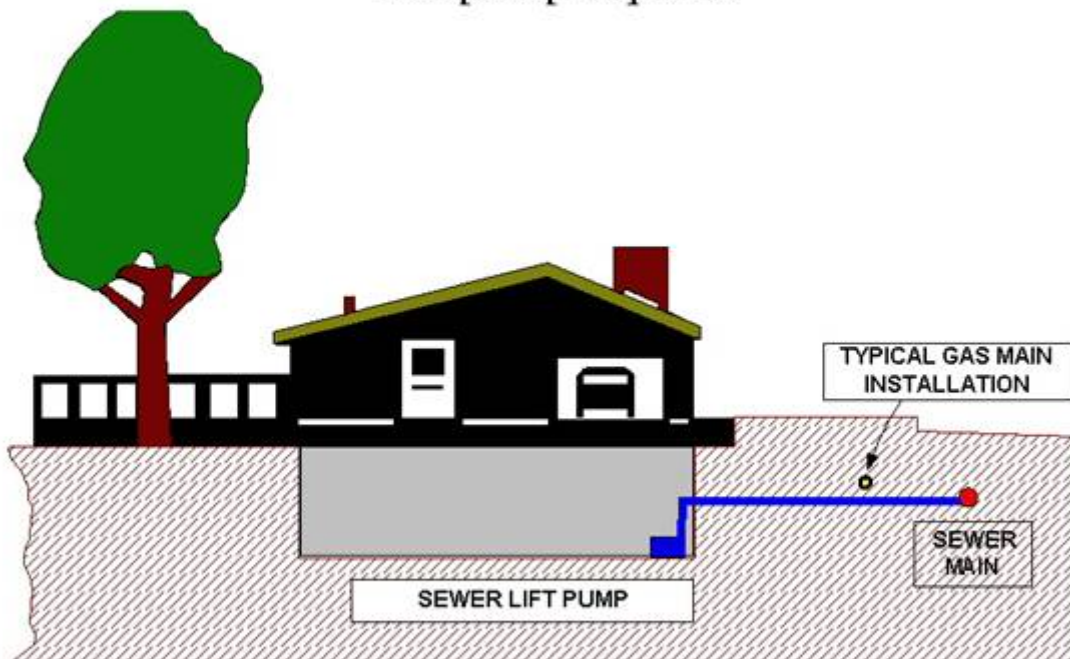

Home with Basement - Sewer Lift Pump Required

1. A visual inspection of the basement would show that the sewer utilizes a lift pump and exits the sidewall at a depth of a typical gas main installation.
2. This is considered a "High Risk Sewer Lateral" if the sewer lateral can't be located and exposed.

A-6. Elevated Lot - Rear Walkout - Sewer Exits Through Sidewall

Typical Sewer Installation Elevated Lot Rear Walkout

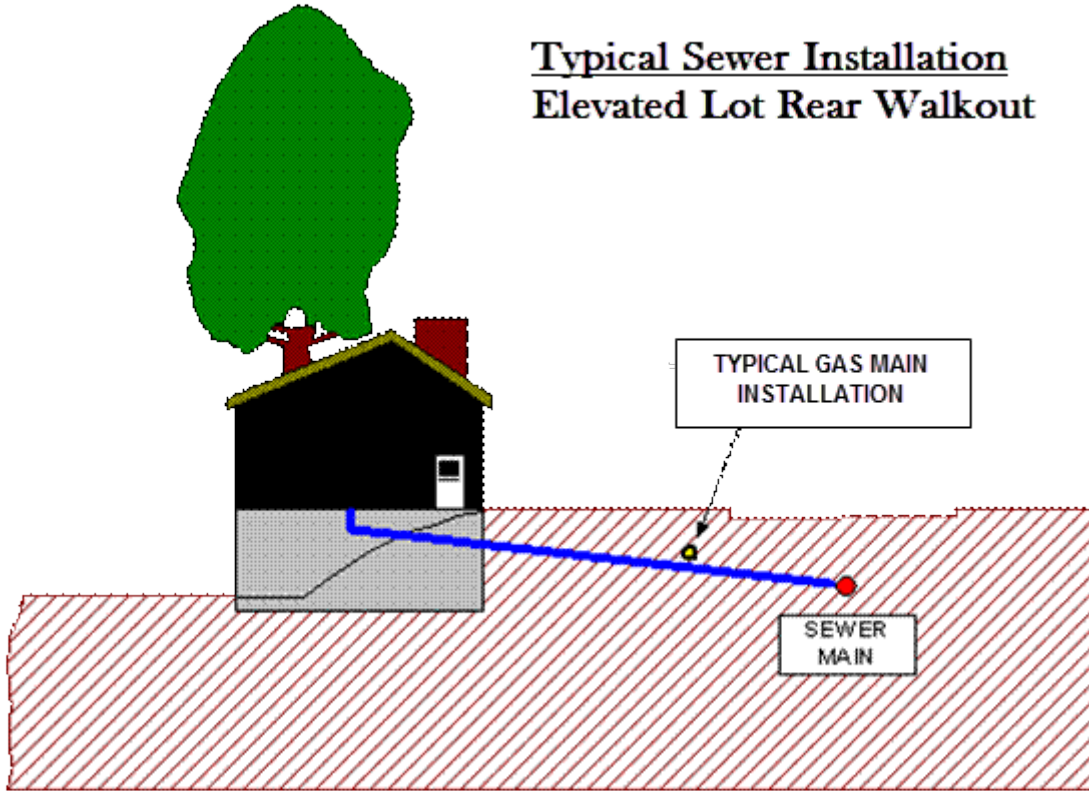

Elevated Lot - Rear Walkout - Sewer Exits Through Sidewall

1. A visual inspection of the basement would show that the sewer exits the sidewall at a depth of a typical gas main installation.
2. This is considered a "High Risk Sewer Lateral" if the sewer lateral can't be located and exposed.

A-7. Elevated Lot - Rear Walkout - Sewer Exits Through Floor

Typical Sewer Installation Elevated Lot Rear Walkout

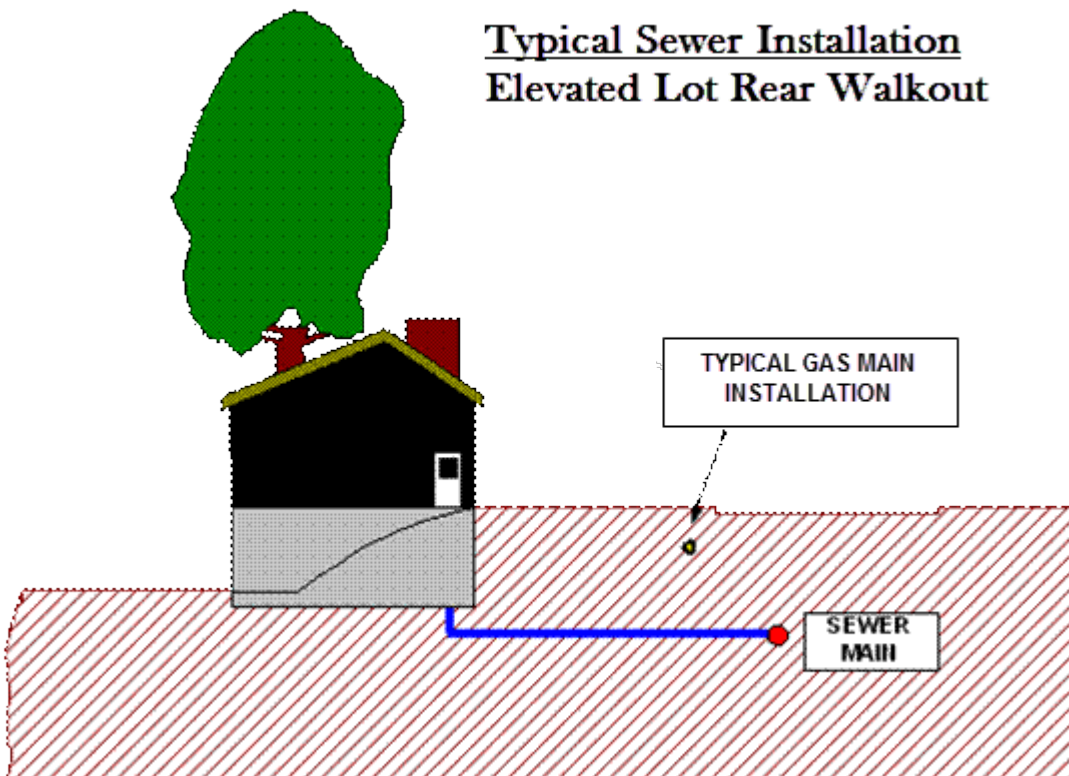

UNCONTROLLED IF PRINTED

Elevated Lot - Rear Walkout - Sewer Exits Through Floor

1. A visual inspection of the basement would show that the sewer exits through the floor at a depth significantly greater than a typical gas main would be installed.
2. A sewer line installation as pictured below would not have to be physically located before boring.
3. This is not considered a High Risk Sewer Lateral.

A-8. Level Lot - Home on Slab - Outside Cleanout

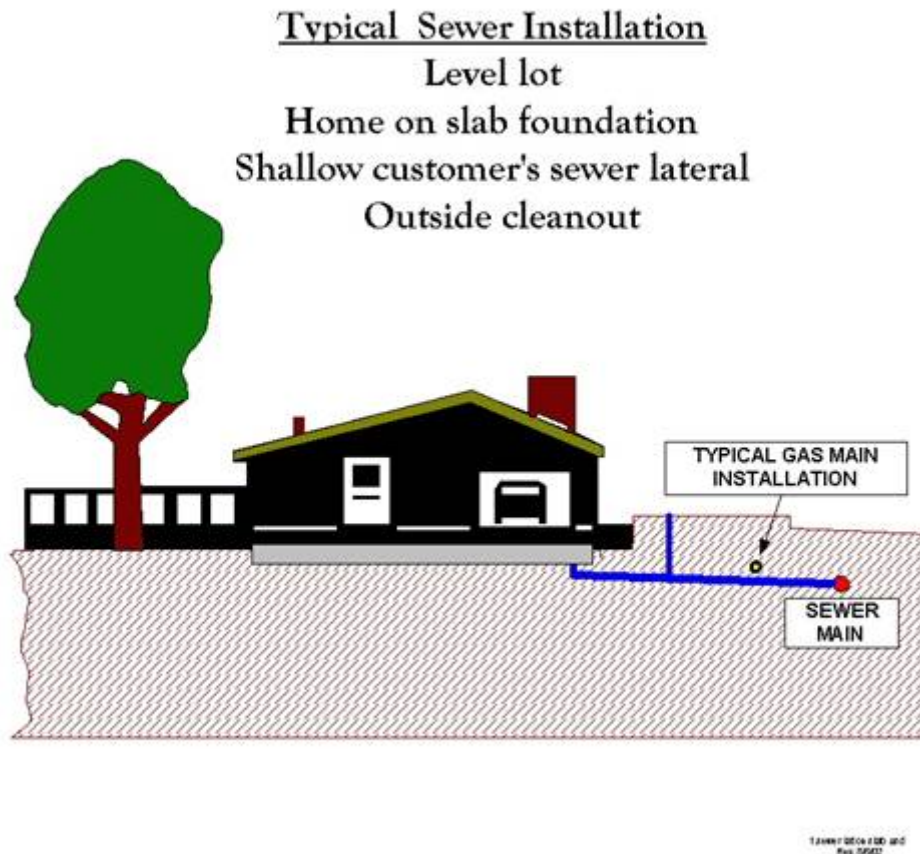

Level Lot - Home on Slab - Outside Cleanout

1. A visual inspection would show that the home is built on a slab foundation.
2. The sewer depth would be approximately the same as a typical gas main installation.
3. This is considered a "High Risk Sewer Lateral" if the sewer lateral can't be located and exposed.

A-9. Home on Slab - Shallow Sewer Lateral - No Outside Cleanout

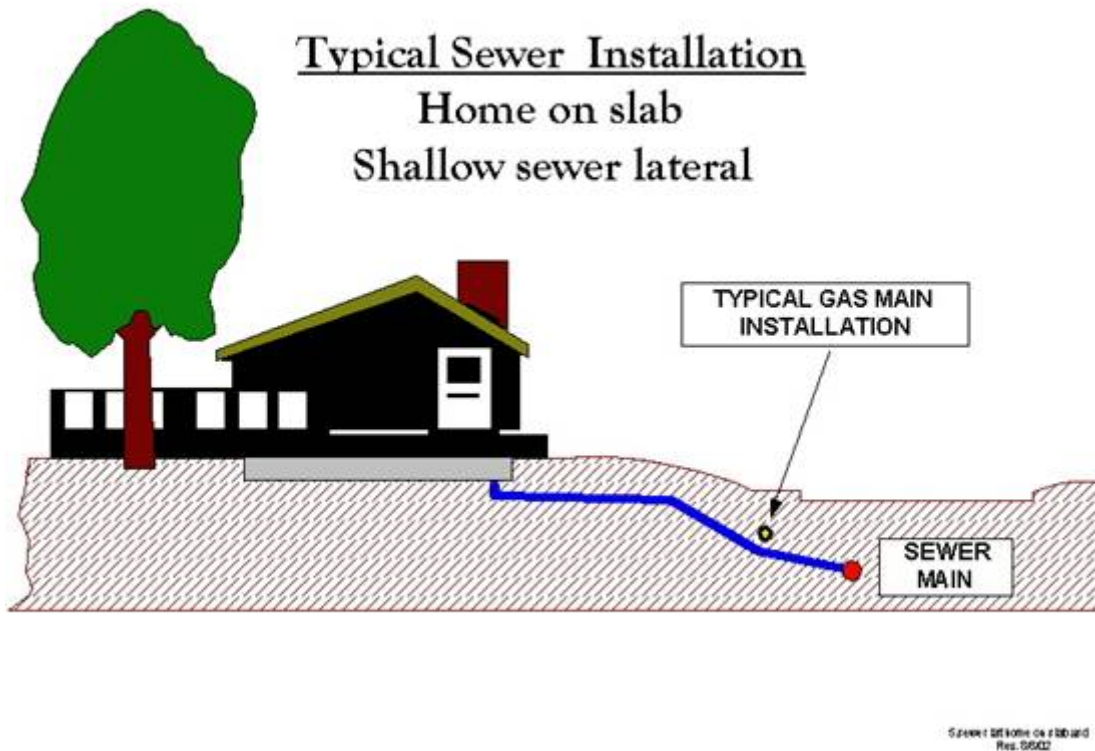

Home on Slab - Shallow Sewer Lateral - No Outside Cleanout

1. A visual inspection would show that the home is built on a slab foundation.
2. The sewer depth would be approximately the same as a typical gas main installation.
3. This is considered a "High Risk Sewer Lateral" if the sewer lateral can't be located and exposed.

A-10. Home on Slab - Very Elevated Lot

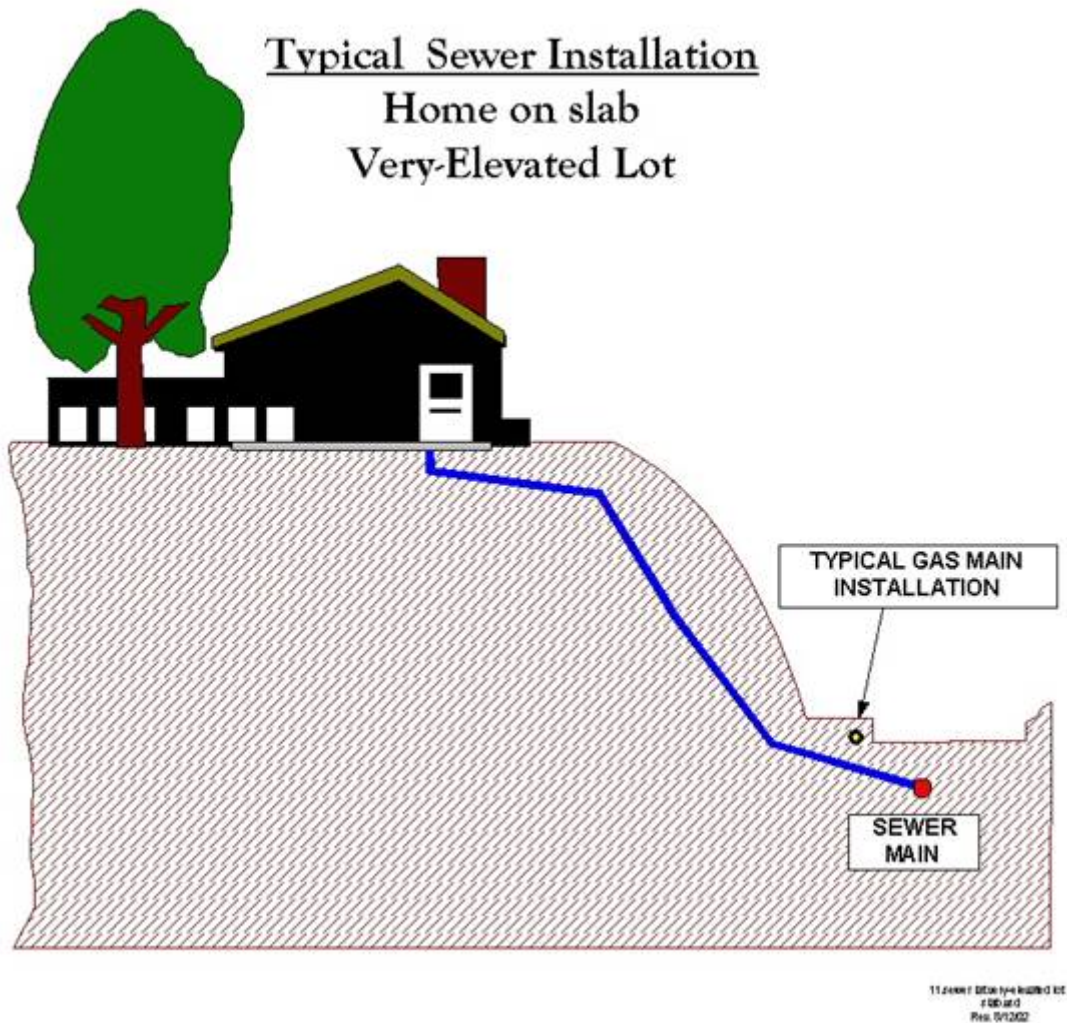

Home on Slab - Very Elevated Lot

1. A visual inspection would show that the home is built on a slab foundation.
2. Even though this is an elevated lot, the sewer depth would be approximately the same as a typical gas main installation.
3. This is considered a "High Risk Sewer Lateral" if the sewer lateral can't be located and exposed.

A-11. Home with Crawl Space - Shallow Sewer Lateral

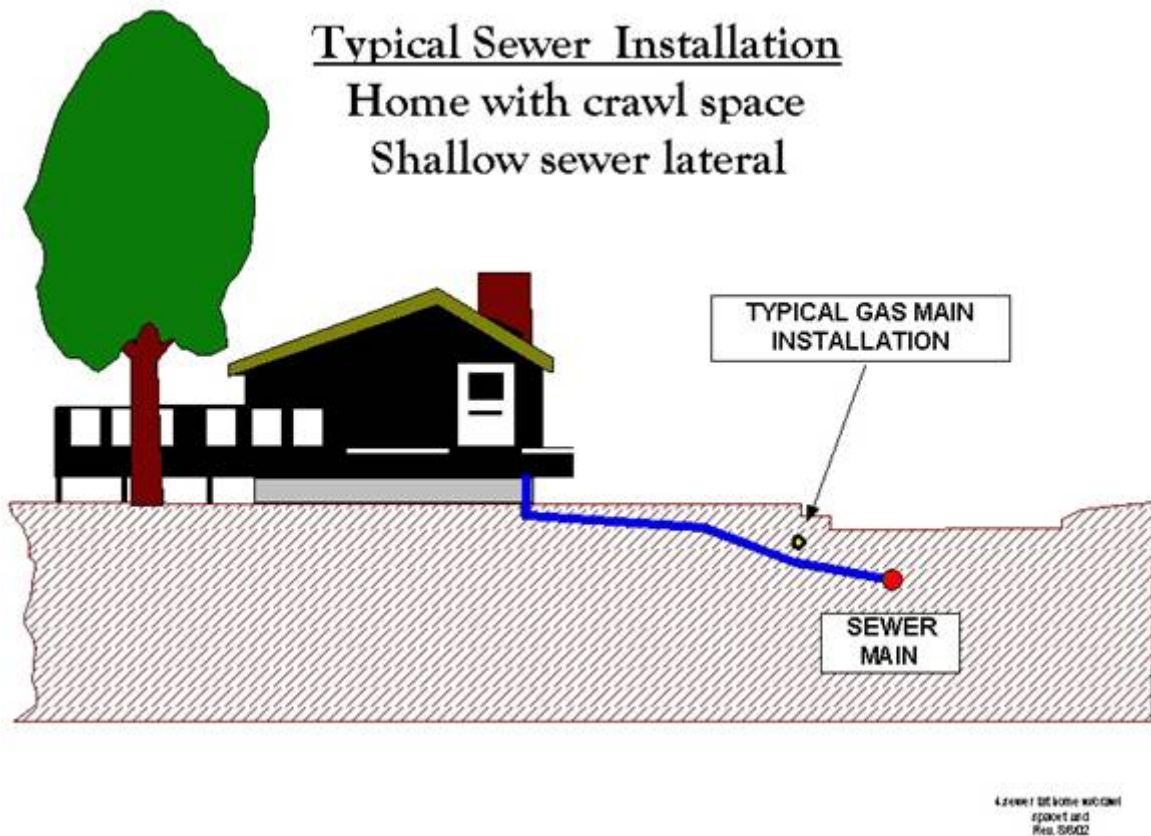

Home with Crawl Space - Shallow Sewer Lateral

1. A visual inspection would show that the home is built on a crawl space.
2. The sewer depth would be approximately the same as a typical gas main installation.
3. This is considered a "High Risk Sewer Lateral" if the sewer lateral can't be located and exposed.

A-12. Home with Crawl Space - Very Elevated Lot

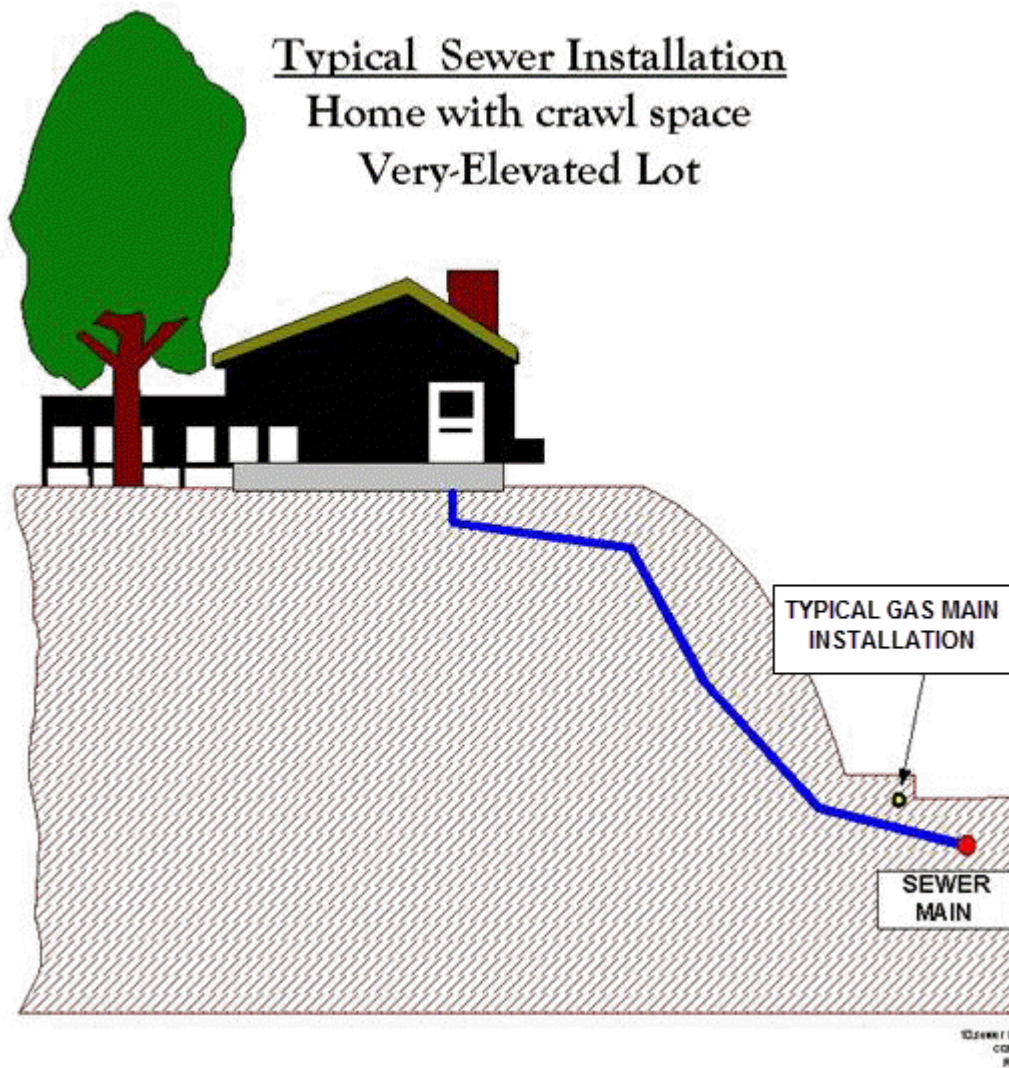

Home with Crawl Space - Very Elevated Lot

1. A visual inspection would show that the home is built on a crawl space.
2. Even though this is an elevated lot, the sewer depth would be approximately the same as a typical gas main installation.
3. This is considered a "High Risk Sewer Lateral" if the sewer lateral can't be located and exposed.

Appendix B - Sample Door Tag

Boring Equipment Used on Nearby Gas Main

[\(View/download PDF version\)](#)

Form F 5775
Stock No. 37-22-236
Rev. 5/12

3/4"

1 3/8"

1 1/2"

4 1/4"

Job: CT75186
1st proof: 6/11/12
Ink: Black
Paper: 65#
Yellow Hopper
Hots

For Information Only:

Boring Equipment Used on Nearby Gas Main

We recently installed a new gas main near your home or business using underground boring equipment.

The use of boring equipment helps minimize property damage. However, on rare occasions—despite the precautions we take—the bore may enter a sewer line.

In the unlikely event you experience a sewer blockage at any time following the completion of our construction, please notify us at the number below before contacting a sewer repair contractor.

Thank you.

1.800.755.5000

¡IMPORTANTE!

Si necesita ayuda para entender esta nota, por favor use el servicio de traducción contactando al número de la compañía Ameren localizado al lado del encajonado marcado de esta tarjeta.



Appendix C - Sample Cross Bore Brochure

[\(View/download PDF version\)](#)

UNCONTROLLED IF PRINTED

Learn to Recognize Gas Leaks

Ameren Illinois injects an odorant into natural gas to help people detect natural gas leaks. It usually smells like sulfur or rotten eggs, but in some instances, this odor may not be apparent. So also LOOK and LISTEN for natural gas leaks, and stay alert for ANY of these warning signs:

- A distinctive, sulfur-like odor
- A hissing, whistling, or roaring sound
- An unusual area of dead vegetation, blowing dirt, or bubbling water
- Exposed pipeline after an earthquake, fire, flood, or other disaster

If you suspect a gas leak, warn others, leave the area quickly, and call 911 and Ameren Illinois immediately at 800.755.5000.

Some Gas Leak Warning Signs



If you work for a public sewer agency:

- Be alert for cross bores in sewer mains and review the precautions in this brochure before attempting to clear any blockage.
- If you see a utility crew working in an area where you know there to be sewer lines, stop and discuss the cross bore issue with them.

For more safety tips, visit amerenillinois.e-smartonline.net/worker

© 2016 Culver Media, LLC, #97545



Safety Materials Distribution
104 Bridge Road
Salisbury, MA 01952

Caution: Natural Gas and Electric Lines May Unintentionally Intersect Sewer Lines
Safety Tips For Plumbers, Sewer Cleaners and Drain Cleaners

#10264



Caution: Natural Gas and Electric Lines May Unintentionally Intersect Sewer Lines



Safety Tips For Plumbers, Sewer Cleaners and Drain Cleaners

Please review this safety brochure carefully and share these procedures with employees and coworkers. Please post in common areas such as your meeting room or work trailer. For more safety tips, visit amerenillinois.e-smartonline.net/worker.

Be Alert for "Cross Bores" in Sewer Lines!

Utility Lines May Intersect Sewer Lines

Ameren Illinois uses various boring techniques to install underground gas piping and electric lines. Despite the precautions we take, on rare occasions a bore may puncture a sewer line. As a result, a utility line can be unintentionally installed directly through a sewer line in what is known as a "cross bore."

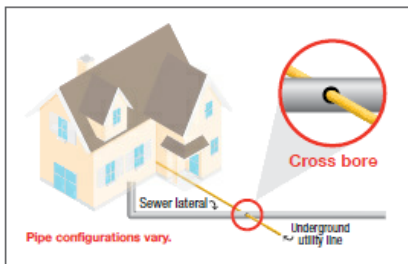

A cross bore that intersects a sewer line will impede the flow of sewage and, eventually, lead to a blockage. Clearing the blockage can damage the utility line, creating a potentially dangerous situation. For example, a nicked or severed pipe could allow natural gas to enter a building, and a damaged electric line could allow contact with high-voltage electric current.

If you encounter a blockage in a sewer line—it could be a cross bore. If you suspect a cross bore, please suspend work activity and call Ameren Illinois at 800.755.5000. We will promptly inspect the situation and make any necessary corrections to support public safety, and the safety of your workers.

If you work with natural gas fuel lines, please take these precautions:

- Always use a combustible gas indicator (CGI) or other gas detection equipment during purging operations or when otherwise working on or around gas piping systems. Do NOT rely on your sense of smell alone to detect the presence of natural gas.
- Never purge the contents of a gas line into an enclosed space. Discharge directly to an outdoor location, per the National Fuel Gas Code (NFPA 54 8.3.1.3).

Take These Cross Bore Precautions

Take these steps before, during and after you attempt to clear a blockage in any sewer line:

- **Before Cleaning.** Call 811 so facility owners can mark the location of their underground lines at the property. If these marks cross the path of the sewer line, a cross bore may be causing the blockage. Also ask the property owner about any recent nearby utility installation work that could have created a cross bore. If you suspect a cross bore is causing the blockage, take these precautions:
 - If you own or can obtain access to an inline camera, use it to assess the blockage before attempting to clear it. If the camera view is obstructed due to the clog, vacuum it out first.
 - If a camera is not available, run a hydro-jetter through the line to clear it. Do not use a cutting tool.
- **During Cleaning.** If you cannot verify the nature of the obstruction, use the least invasive equipment possible, such as a hydro-jetter. If you sense resistance that does not resemble a tree root or other common obstruction, do not force it. Stop immediately and call Ameren Illinois at 800.755.5000.
- **After Cleaning.** Natural gas pipes are typically plastic; Electric lines may be direct buried or run through a conduit. If you have used a cutting tool, look for yellow, orange or gray plastic on the blades when you withdraw it. Watch for bubbles escaping from the entry point of the clearing equipment or toilet and/or use a combustible gas indicator or other gas detection equipment, if available. If you think you have hit a gas or electric line, act fast! Take the steps below, even if damage appears minor.

If You Hit a Gas Line:

- Immediately warn others and evacuate the area; if indoors, immediately evacuate the premises. From a safe location, call 911 and Ameren Illinois at 800.755.5000.
- Extinguish all open flames. Do not use matches or lighters and do not attempt to light an appliance.
- Do not use any phones, electric switches, thermostats or appliance controls. All of these devices, including battery-operated equipment, can cause sparks and ignite natural gas.
- Do not start or turn off vehicles or motorized equipment. Abandon any motorized equipment you may be operating.
- Do not attempt to find the source of the leak or to repair a leak.
- Do not operate underground gas valves.

If you suspect a gas leak, warn others, leave the area quickly, and call 911 and Ameren Illinois immediately at 800.755.5000.

Call 811 or contact JULIE at www.illinois1call.com at least two full business days before you dig or move earth in any way.

Know what's below. Call before you dig.

If You Hit an Electric Line:

- Call Ameren Illinois immediately for any electric line contact.
- Leave the premises and abandon tools and equipment. Equipment that remains in contact with a buried power line poses a serious electric shock hazard.
- Stay away from the area, and warn others to stay away, until Ameren Illinois personnel tell you it is safe to return.
- If someone has been shocked, call 911 immediately.

Watch our safety training video at amerenillinois.e-smartonline.net/worker.



UNCONTROLLED IF PRINTED

BORING

October 1, 2020

BORE 3 Forms and Reference Materials

Click on the links below to open the documents.

Reference Materials

1. [Yellow Box WMS-1B Instructions](#)
2. [Comtek BST-50b Manual](#)
3. [Comtek PR-216 Operator Manual](#)
4. [Shure VP64 User Guide](#)
5. [Door Tag Stock Code 37 22 236](#)
6. [Ameren Crossbore Brochure v4 - Caution: Natural Gas and Electric Lines May Unintentionally Intersect Sewer Line](#)

End of Section.

Document Rescission

BORE 4 Boring: Forms and Reference Materials, April 1, 2017.

Revision Notes

Location of Changes	Summary of Changes
Not applicable.	This is a new document.

CLAS-Class Location and Consequence Areas

CLASS LOCATION AND CONSEQUENCE AREAS

October 1, 2020

CLAS 0 Table of Contents

[CLAS 1 Class Location and Consequence Areas: Requirements](#)

- Section 1.0 Purpose
- Section 2.0 Scope
- Section 3.0 Target Audience
- Section 4.0 Class Location Unit
- Section 5.0 Class Locations
- Section 6.0 Class Location Determination
- Section 7.0 Class Location Example
- Section 8.0 High Consequence Areas
- Section 9.0 Moderate Consequence Areas
- Section 10.0 Identified Sites
- Section 11.0 Potential Impact Circle
- Section 12.0 Records
- Operator Qualification
- Compliance Requirements
- Reference Documents
- Document Rescission

[CLAS 2 Class Location and Consequence Areas: Annual Class Location and HCA - MCA Study](#)

- Section 1.0 Purpose
- Section 2.0 Scope
- Section 3.0 Target Audience
- Section 4.0 General
- Section 5.0 Action Required for Review of a Class Location Change
- Section 6.0 Action Required for an HCA or MCA Change
- Section 7.0 Records
- Operator Qualification

UNCONTROLLED IF PRINTED

Compliance Requirements

Reference Documents

Document Rescission

End Table of Contents.

Document Rescission

CLAS 0 Class Location and Consequence Areas: Table of Contents, July 1, 2020.

Revision Notes

Location of Changes	Summary of Changes
Not applicable.	This is a new document.

CLASS LOCATION AND CONSEQUENCE AREAS

October 1, 2021

CLAS 1 Requirements

1.0 Purpose

This procedure defines terms, measurements, and calculations used to identify and maintain Class Locations, High Consequence Areas, and Moderate Consequence Areas in accordance with 49 CFR §§ 192.5, 192.903, 192.905, and 192.921.

2.0 Scope

This document addresses the following:

[3.0 Target Audience](#)

[4.0 Class Location Unit](#)

[5.0 Class Locations](#)

[6.0 Class Location Determination](#)

[7.0 Class Location Example](#)

[8.0 High Consequence Areas](#)

[9.0 Moderate Consequence Areas](#)

[10.0 Identified Sites](#)

[11.0 Potential Impact Circle](#)

[12.0 Records](#)

3.0 Target Audience

- Gas Compliance.
- Gas Field Personnel.
- Gas Integrity Management Personnel.
- Gas Supervisors.

4.0 Class Location Unit (§192.5(a))

- 4.1 An onshore area that extends 220 yards on either side of the center line of any continuous 1-mile length of a pipeline.
- 4.2 The class location ends 220 yards from the last feature that defines the class location.
- 4.3 Each separate dwelling unit in a multiple dwelling unit building is counted as a separate building intended for human occupancy.

5.0 Class Locations (§192.5(b) and (c))

Class 1	<ul style="list-style-type: none"> • Any Class Location Unit that has 10 or less buildings intended for human occupancy.
Class 2	<ul style="list-style-type: none"> • Any Class Location Unit that has more than 10 but less than 46 buildings intended for human occupancy.

	<ul style="list-style-type: none"> • When all buildings intended for human occupancy within Class 2 or Class 3 locations are in a single cluster, the class location ends 220 yards from the nearest building in the cluster.
Class 3	<ul style="list-style-type: none"> • Any Class Location Unit that has 46 or more buildings intended for human occupancy; or an area where the pipeline lies within 100 yards of either a building or a small, well-defined area (such as a playground, recreation area, outdoor theater, or other place of public assembly) that is occupied by 20 or more persons on at least 5 days a week for 10 weeks in any 12-month period (the days and weeks need not be consecutive). • When all buildings intended for human occupancy within a Class 2 or Class 3 location are in a single cluster, the class location ends 220 yards from the nearest building in the cluster.
Class 4	<ul style="list-style-type: none"> • Any Class Location Unit where buildings of 4 or more stories above ground are prevalent. • A Class 4 location ends 220 yards from the nearest building with 4 or more stories above ground.

6.0 Class Location Determination

- 6.1 Use the Sliding Mile method to determine the class locations of Ameren Illinois' (AIC's) gas pipelines.
 - 6.1.1 Count the number of structures within 660 feet or 220 yards of the centerline of the pipeline along a continuous mile of pipe.
- 6.2 Pipeline Integrity Management staff utilizes the following process for determining class location:
 - 6.2.1 AIC's GIS mapping system is used to determine the 660 feet (220 yards) buffer on either side of the transmission line.
 - 6.2.2 Integrity Management staff annually field verifies the number of dwellings within the 660 feet (220 yards) class location boundary and updates the information in AIC's GIS mapping system.
 - 1. Aerial Imagery may be used to facilitate the count.
 - 6.2.3 Pipeline Integrity Management staff utilizes software to simulate the sliding mile to determine class locations.

7.0 Class Location Example

- 7.1 The diagram below shows the class locations determined for the pipeline using the Sliding Mile Method.
 - 7.1.1 The house counts within the various sections of the pipeline are shown on the diagram.
 - 7.1.2 Use the most restrictive class location to determine the class location for any section.

Each separate dwelling unit in a multiple dwelling unit building is counted as a separate building intended for human occupancy.

7.1.3 See the following notes for Class 2 and Class 3 determinations.

When a cluster of buildings intended for human occupancy requires a Class 2 or Class 3 location, the class location boundary ends 660 feet or 220 yards from the nearest building in the cluster.

Do not count structures that are outside the cluster that created the Class 2 or Class 3 location.

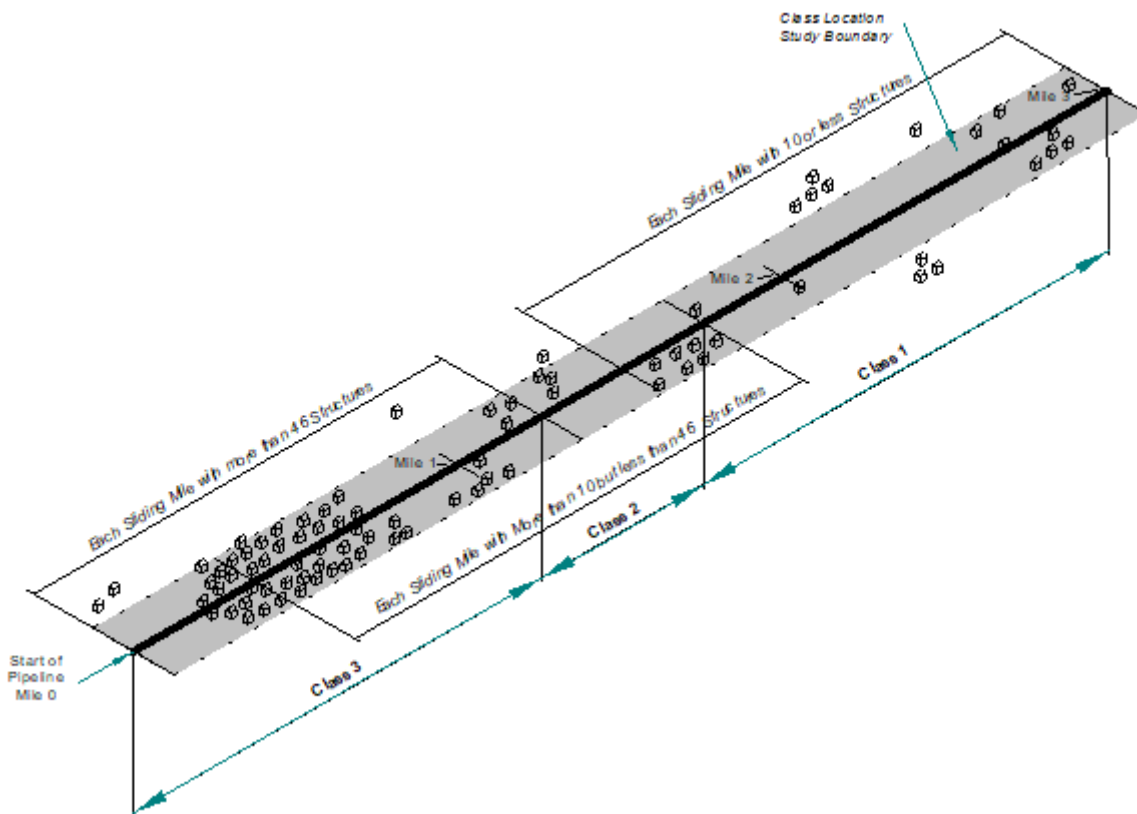

7.1.4 See [Section 12.0](#) for record keeping.

8.0 High Consequence Areas (§192.903(2))

8.1 A High Consequence Area (HCA) is a transmission line segment that AIC has determined meets one of the following requirements:

8.1.1 The Potential Impact Circle (PIC) touches or contains an Identified Site. See:

1. [Section 10.0](#).
2. [Section 11.0](#).

- 8.1.2 Has 20 or more buildings intended for human occupancy within the potential impact circle.

9.0 Moderate Consequence Areas (§192.3)

9.1 A Moderate Consequence Area (MCA) is an onshore area that is within a PIC containing either:

9.1.1 Five or more buildings intended for human occupancy; or

9.1.2 Any portion of the paved surface, including shoulders, of a:

1. Designated interstate, or
2. Other freeway, or
3. Expressway, or
4. Any other principal arterial roadway with 4 or more lanes (As defined in the Federal Highway Administration's Highway Functional Classification Concepts, Criteria and Procedures, Section 3.1).
5. And that does not meet the definition of HCA.

9.2 The length of the MCA extends axially along the length of the pipeline from the outermost edge of the first PIC containing:

9.2.1 Five or more buildings intended for human occupancy, or

9.2.2 Any portion of the paved surface, including shoulders, or:

1. Any designated interstate, or
2. Freeway, or
3. Expressway, or
4. Other principal arterial roadway with 4 or more lanes

To the outermost edge of the last contiguous PIC containing any of the items listed in 9.2 above.

10.0 Identified Sites (§192.903 (a), (b), and (c))

10.1 An outside area or open structure that is occupied by 20 or more persons on at least 50 days in any 12-month period. The days need not be consecutive.

10.1.1 Examples include:

- Beaches,
- Areas outside a rural building such as a religious facility,
- Recreational areas near a body of water,
- Stadiums,
- Outdoor theaters,
- Camping grounds,
- Recreational facilities, or
- Playgrounds,

OR

10.2 A building that is occupied by 20 or more persons on at least 5 days a week for 10 weeks in any 12-month period. The days and weeks need not be consecutive.

10.2.1 Examples include:

- Religious facilities,
- Roller-skating rinks.
- 4-H facilities,
- General stores,
- Community centers, or
- Office buildings,

OR

10.3 A facility occupied by persons who are confined, are of impaired mobility, or would be difficult to evacuate.

10.3.1 Examples include:

- Hospitals,
- Assisted-living facilities.
- Retirement facilities,
- Day-care facilities,
- Schools, or
- Prisons,

11.0 Potential Impact Circle (§192.903)

11.1 A Potential Impact Circle (PIC) has a radius within which the potential failure of a pipeline could have significant impact on people or property. The Potential Impact Radius (PIR) is the radius of a PIC and is calculated for a transmission line using the following formula:

$$PIR = 0.69\sqrt{PD^2}$$

Where: PIR is expressed in feet

P = MAOP of the line in pounds per square inch (PSI)

D = actual outside diameter of the transmission line in inches

PIR Example:

P = 720 psi

D = 12.75 inches

$PIR = 0.69\sqrt{720(12.75)^2} = 236.06$ feet

11.2 AIC adds a 10% buffer to the PIR.

AIC Buffer Example:

$PIRAIC = 1.1(PIR)$

$PIRAIC = 1.1(236.06) = 259.67$

PIRAIC = 260 feet

12.0 Records (§§ 192.905, 192.921(f))

12.1 Gas Integrity Management Personnel are responsible for:

UNCONTROLLED IF PRINTED

12.1.1 Demonstrating how each class location is determined.

12.1.2 Identifying, maintaining, and documenting the class location, HCAs, and MCAs on all transmission lines.

12.1.3 Identifying any changes in class location and changes in HCAs and MCAs.

12.1.4 Notifying the Gas Supervisor of changes that affect leak surveys and patrols.

12.1.5 Working with Compliance to update leak surveys and patrol frequency.

End of Instructions.

Operator Qualification (OQ) Required?

YES.

1311: Inspect Pipeline Surface Conditions - Patrol Right of Way or Easement.

Appendices

NONE.

Attachments

NONE.

Compliance Requirements

49 CFR §192.5 Class locations.

49 CFR §192.903 What definitions apply to this subject?

49 CFR §192.905 How does and operator identify a high consequence area?

49 CFR §192.921 How is the baseline assessment to be conducted?

Reference Documents

NONE.

Document Rescission

CLAS 1 Class Location and Consequence Areas: Requirements, December 1, 2020.

Revision Notes

Location of Changes	Summary of Changes
Subsection 6.2.3	Integrity Management utilizes software to simulate the sliding mile.
Section 11.0 Potential Impact Circle	Corrected the calculation for PIR and the AIC buffer.

CLASS LOCATION AND CONSEQUENCE AREAS

October 1, 2021

CLAS 2 Annual Class Location and HCA - MCA Study

1.0 Purpose

This procedure describes the details of the annual class location and HCA - MCA study in accordance with 49 CFR §§ 192.609, 192.611, 192.905, 192.911, and 192.921.

2.0 Scope

This document addresses the following:

[3.0 Target Audience](#)

[4.0 General](#)

[5.0 Action Required for Review of a Class Location Change](#)

[6.0 Action Required for an HCA or MCA Change](#)

[7.0 Records](#)

3.0 Target Audience

- Gas Compliance.
- Gas Engineers.
- Gas Field Personnel.
- Gas Integrity Management Personnel.
- Gas Supervisors.

4.0 General (§192.911(k))

CLAS 2 supports the management of change required by Ameren Illinois' Integrity Management Plan. Information for CLAS 2 activities is provided by the Continuing Surveillance ([CNTS](#)) and Pipeline Patrol ([PTRL](#)) sections.

- 4.1 The Pipeline Integrity staff shall conduct an annual pipeline review and record areas and locations of possible changes in class locations, HCAs, and MCAs.

Changes in class location:

1. Can affect the patrol and leak survey requirements for the pipeline.
2. May change the operating parameters for the pipeline.

Changes in HCA or MCA can affect:

1. The Integrity Management Plan.

UNCONTROLLED IF PRINTED

2. The pipeline integrity inspection requirements for that area of the pipeline.

- 4.2 The Pipeline Integrity staff shall complete a field review in the vicinity of the transmission pipeline when a new potential HCA/MCA is identified or an existing HCA/MCA changes.
- 4.3 Indications of possible changes in class location and HCA include the following:
- 4.3.1 Changes in the number of buildings intended for human occupancy.
- 4.3.2 New buildings, or changes in use for existing buildings.
- 4.3.3 Changes in land use such as new:
- Playgrounds.
 - Recreational areas.
 - Camps and campgrounds.

5.0 Action Required for Review of a Class Location Change (§§ 192.609, 192.611)

- 5.1 The Pipeline Integrity staff shall immediately perform a Class Location Study and review whenever there is an indication of a class location change for a segment of existing steel transmission pipeline operating at or above 40% of SMYS to determine:
- 5.1.1 The present class location for the segment involved.
- 5.1.2 The design, construction and testing procedures followed in the original construction, and a comparison of these procedures with those required for the present class location.
- 5.1.3 The physical condition of the segment to the extent it can be ascertained from available records.
- 5.1.4 The operating and maintenance history of the segment.
- 5.1.5 The maximum actual operating pressure and the corresponding operating hoop stress for the pipeline segment involved.
- 5.1.6 The actual area affected by the population density increase.
- 5.2 The Pipeline Integrity Management staff shall confirm or revise the MAOP of the affected pipeline after the Class Location Study and review are completed.
- 5.2.1 Complete the confirmation or revision of the MAOP within 24 months of the change in class location.
- 5.2.2 Actions required for pipelines operating at less than 40% of SMYS are:
1. Identify any additional survey and/or patrol requirements.
 2. Update the class location records, electronic mapping, and Integrity Management records.
- 5.2.3 Actions required for pipelines operating at or above forty percent (40%) of SMYS are:
1. If the segment involved has been previously tested in place for a period of not less than 8 hours, the MAOP must be confirmed or reduced so that the MAOP and its corresponding hoop stress will not exceed the following:

UNCONTROLLED IF PRINTED

- 1 a. In Class 2 locations: 0.8 times the test pressure and 72% of SMYS.
- 1 b. In Class 3 locations: 0.667 times the test pressure and 60% of SMYS.
- 1 c. In Class 4 locations: 0.555 times the test pressure and 50% of SMYS.

5.2.4 Identify any additional survey and/or patrol requirements and update the class location records, electronic mapping, and Integrity Management records.

6.0 Action Required for an HCA or MCA Change (§§ 192.905, 192.921)

6.1 The Pipeline Integrity staff shall conduct a study of the affected HCA or MCA corridor and update Ameren Illinois' Integrity Management Plan to reflect any necessary changes within 12 months of completion of an HCA/MCA field review of a potential HCA/MCA change.

7.0 Records

7.1 See [CLAS 1 Section 12.0](#) Records for record keeping.

End of Instructions.

Operator Qualification (OQ) Required?

YES.

1311: Inspect Pipeline Surface Conditions - Patrol Right of Way or Easement.

Appendices

NONE.

Attachments

NONE.

Compliance Requirements

49 CFR §192.609 Change in class location: Required study.

49 CFR §192.611 Change in class location: Confirmation or revision of MAOP.

49 CFR §192.905 How does and operator identify a high consequence area?

49 CFR §192.911 What are the elements of an integrity management program?

49 CFR §192.921 How is the baseline assessment to be conducted?

Reference Documents

[CLAS 1 Class Location and Consequence Areas: Requirements.](#)

ASME/ANSI B31.8S, Managing System Integrity of Gas Pipelines, current edition with addenda.

Document Rescission

CLAS 2.2 Class Location and Consequence Areas: Annual Class Location and HCA - MCA Study, October 1, 2020.

Revision Notes

Location of Changes	Summary of Changes
---------------------	--------------------

UNCONTROLLED IF PRINTED

Paragraph 5.1.5	Removed pressure gradient language and NOTE.
-----------------	--

CNTS-Continuing Surveillance

CONTINUING SURVEILLANCE

October 1, 2020

CNTS 0 Table of Contents

[CNTS 1 Continuing Surveillance: Requirements](#)

Section 1.0 Purpose

Section 2.0 Scope

Section 3.0 Target Audience

Section 4.0 General

Section 5.0 Surveillance Responsibilities of Gas Field Personnel

Section 6.0 Surveillance Responsibilities of Non-Gas Field Personnel

Section 7.0 Corrective Action Responsibilities of Gas Supervisors

Section 8.0 System Review Responsibilities of Gas Supervisors

Section 9.0 System Review Responsibilities of Gas Operations and Services Supervisors

Section 10.0 System Review Report Responsibilities of Gas Superintendents

Operator Qualification

Attachments

Attachment 1 - System Review Form

Compliance Requirements

Reference Documents

Document Rescission

[CNTS 2 Continuing Surveillance: Surface Subsidence Areas](#)

Section 1.0 Purpose

Section 2.0 Scope

Section 3.0 Target Audience

Section 4.0 General

Section 5.0 Inspection of Possible Surface Subsidence

Section 6.0 Active Surface Subsidence Area

Section 7.0 Active Mining Operations

Section 8.0 Landfills

Section 9.0 Embankments

Section 10.0 Records

UNCONTROLLED IF PRINTED

- Operator Qualification
- Compliance Requirements
- Reference Documents
- Document Rescission

End Table of Contents.

Document Rescission

CNTS 0 Table of Contents: Continuing Surveillance, October 1, 2011.

Revision Notes

Location of Changes	Summary of Changes
Not applicable.	This is a new document.

1.0 Purpose

This procedure outlines Ameren Illinois' (AIC's) continuing surveillance program in accordance with 49 CFR §192.613.

2.0 Scope

This document addresses the following:

[3.0 Target Audience](#)

[4.0 General](#)

[5.0 Surveillance Responsibilities of Gas Field Personnel](#)

[6.0 Surveillance Responsibilities of Non-Gas Field Personnel](#)

[7.0 Corrective Action Responsibilities of Gas Supervisors](#)

[8.0 System Review Responsibilities of Gas Supervisors](#)

[9.0 System Review Responsibilities of Gas Operations and Services Supervisors](#)

[10.0 System Review Report Responsibilities of Gas Superintendents](#)

Attachments

[Attachment 1 - System Review Form.](#)

3.0 Target Audience

- Contract Locators.
- Corrosion Control Supervisor.
- Electric Personnel.
- Gas Compliance/Training Manager.
- Gas Engineers.
- Gas Field Personnel.
- Gas Supervisors.
- Gas Tech Services Supervisor.
- Pipeline Integrity Management Personnel
- Summer Painters
- Meter Specialist

4.0 General

4.1 Continuing surveillance is:

4.1.1 The periodic visual inspection of facilities is an ongoing process conducted any-time gas and non-gas field personnel are performing routine work activities in and around AIC's facilities.

4.1.2 The review and analysis of records to identify any pipeline facilities experiencing abnormal or unusual operating or maintenance conditions.

4.2 The System Review of an Operating Center is:

4.2.1 The analysis of the data collected from the surveys, patrols, and inspections completed for an Operating Center's transmission and distribution facilities.

4.2.2 Conducted to ensure that changes to facilities do not go undetected.

4.2.3 Recorded on the System Review form at [Attachment 1](#).

4.3 The System Review Report for an Operating Center consists of the System Review forms completed by the Gas Supervisor and Gas Operations and Services for the Operating Center's transmission and distribution facilities.

Gas Operations and Services may include personnel from Corrosion Control, Gas Tech Services, Gas Tech Engineering and Pipeline Integrity Management who have responsibilities for AIC facilities within the Operating Center and Region.

4.4 The System Review Report for a Region consists of the System Review forms for each of their respective Operating Centers.

5.0 Surveillance Responsibilities of Gas Field Personnel

5.1 See [LEAK 2.2](#) Outdoor Investigations when a gas odor or gas leak is discovered.

5.2 Visually inspect for and report to their Gas Supervisor whenever any of the following are discovered.

5.2.1 Indications of unreported excavation activities at or near pipeline facilities.

5.2.2 Possible structures or encroachment located over or adjacent to the gas pipeline.

5.2.3 Evidence of tampering, vandalism, or damage.

5.2.4 Changes in topography that may have an effect on pipeline facilities may include:

1. Subsidence. See [CNTS 2](#) Surface Subsidence Areas.
2. Reduction of cover over transmission and distribution lines resulting from:
 - Wind and water erosion.
 - Drainage and irrigation grading.
 - Vehicular activity.

5.2.5 Failed or defective material.

Collect and submit failed or defective gas material or equipment. See [INVE 2.3](#).

6.0 Surveillance Responsibilities of Non-Gas Field Personnel

6.1 Non-Gas Field Personnel include:

- Contract Locators
- Electric Personnel
- Meter Specialist
- Summer Painters

6.2 Non-gas field personnel shall immediately call AIC's emergency phone number 1.800.755.5000 when a gas odor or a gas leak is discovered.

- 6.3 Meter specialist shall report to their supervisor or code into their processor for further investigation the discovery of evidence related to:
 - 6.3.1 Tampering, vandalism, or damage.
 - 6.3.2 Overbuilding, obstruction, or deterioration of a meter set.
- 6.4 Non-gas field personnel may continue their work after reporting.

7.0 Corrective Action Responsibilities of Gas Supervisors

- 7.1 Ensure that the following actions are taken by the Operating Center:
 - 7.1.1 Correct immediately any condition found and considered to be hazardous.
 - 7.1.2 Correct as soon as practicable any condition found and considered to be unsatisfactory, but which poses no immediate hazard.

8.0 System Review Responsibilities of Gas Supervisors

- 8.1 Perform a System Review of the records and items included below that cover the respective responsibilities for each Operating Center under the Gas Supervisor's jurisdiction.

Record findings on the System Review form at [Attachment 1](#).

- 8.1.1 Leak History
- 8.1.2 Corrosion Deficiencies
- 8.1.3 Class Location/HCA/MCA Changes
- 8.1.4 Odorant Intensity Survey Locations
- 8.1.5 System Maps Updates
- 8.1.6 Inaccessible Facilities Leak Surveys
- 8.1.7 Inside Meters Leak Surveys
- 8.1.8 Facilities That Need Paint
- 8.1.9 Inactive Services (services inactive for 10 or more consecutive years). See [SERV 2.5](#) Inactive Services.
- 8.1.10 Inspect the bulletin board at each gas operating center and/or gas personnel reporting site to ensure current copies AIC's Alcohol and Illegal Drugs Policy and Employee Assistance Program documents are posted.

Post the Alcohol and Illegal Drugs Policy and the Employee Assistance Program documents close together.

- 8.1.11 Submit any failed material. See [INVE 2.3](#) Investigation of Failures.
- 8.1.12 Record any pipeline facilities experiencing abnormal or unusual operating and maintenance conditions.

- 8.2 See [Section 7.0](#) if, at any time during the System Review, a hazardous condition is discovered.
- 8.3 Complete the System Review by March 31 each year.
- 8.4 Forward or e-mail a copy of each System Review form to the appropriate Gas Superintendent.

9.0 System Review Responsibilities of Gas Operations and Services Supervisors

- 9.1 Perform a System Review of the records and items under [Subsection 8.1](#) covering the respective department's responsibilities for the facilities in each Operating Center and Region.

Record findings on the System Review form at [Attachment 1](#).

- 9.2 See [Section 7.0](#) if, at any time during the System Review, a hazardous condition is discovered.
- 9.3 Complete the System Reviews by March 31 each year.
- 9.4 Forward a copy of each System Review form to the appropriate Gas Superintendent.

10.0 System Review Report Responsibilities of Gas Superintendents

- 10.1 Ensure that a System Review form has been completed for each Operating Center within the Region.
- 10.2 Match-up the System Review forms prepared by the Gas Supervisors and the Gas Operations and Services Supervisors for each Operating Center and Region.
- 10.3 Upon completion, e-mail or forward the System Review Reports (see [Subsection 4.3](#) for definition) to:

Manager, Pipeline Safety Compliance
2125 E. State Route 104
Pawnee, IL 62558.

The individual System Review Reports can be submitted and do not have to be consolidated into a Region report.

End of Instructions.

Operator Qualification (OQ) Required?

NO.

Appendices

NONE.

Attachments

UNCONTROLLED IF PRINTED

[Attachment 1 - System Review Form.](#) (PDF file)

Compliance Requirements

49 CFR §192.613 Continuing surveillance.

Reference Documents

[INVE 2.3 Investigation of Incidents: Investigation of Failures](#)

[LEAK 2.2 Leak Management: Outdoor Investigations](#)

[SERV 2.5 Service Line Installation: Inactive Service](#)

Document Rescission

CNTS 1 Continuing Surveillance: Requirements, December 1, 2020.

Revision Notes

Location of Changes	Summary of Changes
Throughout the Section	Meter Specialists replaces Meter Readers
Subsection 8.4	Added "or e-mail"
Subsection 10.3	Added "or e-mail"

CONTINUING SURVEILLANCE

April 1, 2021

CNTS 2 Surface Subsidence Areas

1.0 Purpose

This procedure outlines Ameren Illinois' (AIC's) response to subsidence in accordance with 49 CFR §192.613.

2.0 Scope

This document addresses the following:

[3.0 Target Audience](#)

[4.0 General](#)

[5.0 Inspection of Possible Surface Subsidence](#)

[6.0 Active Surface Subsidence Area](#)

[7.0 Active Mining Operations](#)

[8.0 Landfills](#)

[9.0 Embankments](#)

[10.0 Records](#)

3.0 Target Audience

- Gas Engineers.
- Gas Field Personnel.
- Gas Superintendents.
- Gas Supervisors.
- Gas Tech Services Supervisor.
- Pipeline Integrity Management Personnel.

4.0 General

- 4.1 Surface subsidence may cause the movement of buried and above ground gas pipeline facilities which may adversely affect their integrity and serviceability.
- 4.2 The Gas Supervisor shall notify Pipeline Integrity of all suspected subsidence that may affect gas pipeline facilities.

5.0 Inspection of Possible Surface Subsidence

- 5.1 Inspect any suspected or reported area of possible subsidence for damage to gas facilities.
- 5.2 The inspection shall include:
 - 5.2.1 Leak surveying the affected and surrounding area. See [LEAK 2.2](#) Outdoor Investigations.
 - 5.2.2 Visually inspecting all above ground facilities for potential damage and undue stress or strain on piping.

UNCONTROLLED IF PRINTED

- 5.2.3 Checking all structures, in and adjacent to the affected area, for the presence of natural gas.
- 5.2.4 Reviewing gas construction job files for any compression couplings and fittings installed in the affected area.
 1. Give particular attention to the possibility of compression couplings and fittings installed on service lines.
 2. If compression couplings and fittings are present, consider uncovering the fittings to ensure movement has not caused the pipe to pull out of the fittings.
- 5.2.5 Evaluating the possibility that buried gas pipeline has been displaced or subjected to strains that could affect its integrity and serviceability.

The evaluation may include uncovering and visually inspecting the pipe and associated fittings.

- 5.2.6 Evaluating the possibility that there is active subsidence in the reported area.
- 5.3 Corrective action shall include:
- 5.3.1 Investigating, identifying, and classifying any gas leak. See [LEAK 1 Section 5.0](#) Leak Detection and Classification.
 - 5.3.2 Repairing leaks. See [REPR 1](#).
 - 5.3.3 Replacing or realigning above ground piping subjected to undue stress or strain.
 - 5.3.4 Determining if the pipeline should be taken out of service, replaced, or uncovered to relieve the stress based on its integrity and serviceability.

6.0 Active Surface Subsidence Area

- 6.1 If subsidence is due to inactive mining operations:
 - 6.1.1 Determine if the subsidence is expected to continue or if it is a one-time occurrence by consulting with the Illinois Department of Mines and Minerals and local officials such as:
 - City engineers.
 - Water departments.
 - Street departments.
 - County engineers.
 - 6.1.2 Access the Illinois State Geological Survey's map showing where mines are or have been operated. (www.isgs.illinois.edu/ilmines)
- 6.2 Set up a special leak survey for the subsidence area within Maximo.

Contact a Compliance Specialist for assistance in setting up the special leak survey in Maximo.

- 6.2.1 The special leak survey shall be, at a minimum, an annual survey, once each calendar year, not to exceed 15 months.

1. The Gas Supervisor or Gas Engineering has the discretion to leak survey the area more often depending on the nature and frequency of the subsidence activity.
2. All special leak survey activity shall be completed within ClickMobile and recorded in Maximo.

6.2.2 After 2 years without any further indication of new subsidence in the affected area:

1. Conduct a final leak survey.
2. Retire the special leak survey in Maximo.
3. Return the affected area to its original leak survey and normal survey cycle.

6.3 Take corrective action that may include the steps below to minimize the adverse effects or stresses on gas facilities.

- 6.3.1 Take the gas pipeline temporarily out of service.
- 6.3.2 Install a by-pass line or a replacement pipeline either outside of subsidence area or in an open trench within the subsidence area.
- 6.3.3 Uncover buried gas facilities to relieve pressure from soil movement.
- 6.3.4 Support above ground gas facilities and provide a means for adjusting its supports as the ground moves.
- 6.3.5 Install gas approved flex connector lines at meter sets, if and when appropriate. See Table 1.

Table 1: Approved Flex Braided Connectors

Flex Braided Connectors	
Stock Code	Size
62 54 329	¾ inches x 4 feet long, MNPT
19 66 173	1-inch x 2 feet long, MNPT
62 54 330	1-inch x 3 feet long, MNPT
62 54 331	1-inch x 4 feet long, MNPT

7.0 Active Mining Operations

7.1 If subsidence is due to active mining operations:

7.1.1 Consult with the mining operator about:

1. The mining method being used, such as:
 - Long-wall
 - Room & pillar
2. The anticipated extent of subsidence activity

7.1.2 Identify gas facilities within and adjacent to:

- The active mining operation area.
- The anticipated subsidence area.

- 7.1.3 Conduct an engineering analysis concerning the potential effect of subsidence on existing gas facilities within and adjacent to the proposed subsidence area.
- 7.1.4 Take corrective action to minimize adverse effects or stresses on gas facilities that may include those actions listed under [Subsection 6.3](#).

8.0 Landfills

- 8.1 Subsidence in landfills is due to factors such as the physical and chemical properties of the landfill material and the landfill's setting, construction, operation, and post-operation maintenance.
 - 8.1.1 Avoid placement of gas pipeline facilities under or through a landfill because:
 - The majority of landfill deposits are non-soil materials - making excavation in landfills difficult.
 - Many landfills generate methane gas as waste material decomposes - making natural gas leaks extremely difficult to locate.
 - The weight and chemical composition of landfill material may affect the integrity and serviceability of the pipeline facilities.
 - 8.1.2 Consider relocating the gas pipeline facilities outside of the landfill area if subsidence occurs that could potentially affect the integrity and serviceability of the gas facilities.

9.0 Embankments

- 9.1 A gas pipeline installed within an embankment may experience movement affecting the pipeline's integrity and serviceability due to:
 - 9.1.1 Exterior settlement or erosion of the embankment.
 - 9.1.2 Interior settlement or erosion of the embankment.
 - 9.1.3 Failure of the embankment.
- 9.2 Gas Supervisor, Gas Engineering, or Gas Tech Engineering shall review existing gas construction job files to ascertain:
 - 9.2.1 If any compression couplings and fittings are installed in the affected area.
 - 9.2.2 The type and size of pipeline.
 - 9.2.3 The method of joining the pipe.
 - 9.2.4 The approximate depth of burial.
- 9.3 Gas Supervisor shall consult with the individual responsible for repairing the embankment to determine how and when repairs will be made and if an existing gas pipeline is in conflict with the repair operations.
- 9.4 Appropriate corrective action shall be taken to minimize any adverse effect on the buried gas pipeline. Corrective action could include:
 - 9.4.1 Taking the affected section of pipeline out of service.
 - 9.4.2 Relocating or replacing the pipeline.
 - 9.4.3 Monitoring periodically for leaks.
 - 9.4.4 Encapsulating or removing any compression couplings and fittings.

10.0 Records

- 10.1 The Gas Supervisor shall ensure that activities, leak surveys, patrols, repairs, temporary provisions made or taken are documented within ClickMobile.
- 10.2 Written reports describing activities performed, dates performed, employees performing activities, findings, and corrective action taken shall be retained by the Gas Supervisor, Gas Superintendent, or the Engineer/Supervisor of the group overseeing the activities.
- 10.3 DOJM plans for replacing or relocating gas pipeline facilities.

End of Instructions.

Operator Qualification (OQ) Required?

YES.

- 1231: Inside Gas Leak Investigation.
- 1241: Outside Gas Leak Investigation.
- 1261: Walking Gas Leakage Survey.
- 1271: Mobile Gas Leakage Survey - Flame Ionization.
- 1281: Mobile Gas Leakage Survey - Optical Methane.
- 1291: Locate Underground Pipelines.
- 1311: Inspect Pipeline Surface Conditions - Patrol Right of Way or Easement.
- 1351: Vault Inspection and Maintenance.

Appendices

NONE.

Attachments

NONE.

Compliance Requirements

49 CFR §192.613 Continuing surveillance.

Reference Documents

[LEAK 2.2 Leak Management: Outdoor Investigations.](#)

[LEAK 1 Leak Management: Requirements.](#)

[REPR 1 Repairs: Requirements.](#)

Document Rescission

CNTS 2.01 Continuing Surveillance: Surface Subsidence Areas, January 1, 2018.

Revision Notes

Location of Changes	Summary of Changes
Section 6 – 6.3 Table 1	Removed cancelled stock code. 3/4" x 3' Length

CONF-Confined Space

CONFINED SPACE

October 1, 2022

CONF 0 Table of Contents

CONF 1 Requirements

- 1.0 Purpose
- 2.0 Scope
- 3.0 Target Audience
- 4.0 Definitions
- 5.0 Types of Confined Spaces
- 6.0 Atmospheric Measurements a Confined Space
- 7.0 Identify Other Hazards

Document Rescission

CONF 0 Confined Space: Table of Contents, January 1, 2011

Revision Notes

Location of Changes	Summary of Changes
CONF 1	Reformatted to match October 1, 2020 format

CONFINED SPACE

October 1, 2022

CONF 1 Requirements

1.0 Purpose

This document provides the definition and procedure for Confined Spaces. Confined space entry requirements and procedures are regulated by the Occupational Safety and Health Administration (OSHA). Ameren Illinois (AIC) Safety Department is responsible for administering the OSHA regulations. AIC's Safety Supervisors should be contacted with any questions or concerns regarding confined spaces or confined space entry.

- 1.1 Confined spaces containing gas equipment such as vaults/pits and excavations are regulated by PHMSA, and those requirements are addressed in other O&M sections such as [EXCV 2.9](#) and [VALT 2.1](#).
- 1.2 Before entering a confined space, the employee must assess the environment of the confined space for hazards.
 - 1.2.1 If hazards are identified and cannot be cleared, the "confined space" shall be treated as a "permit required confined space".
- 1.3 This policy will define a "confined space", a "permit required confined space", and outline the measures an employee must follow to avoid potential injury when working in such spaces.
- 1.4 Entry into crawl spaces or attics should be minimized and only performed when other options for lighting appliances are not available.
 - 1.4.1 Workers shall not enter crawl spaces or attics to investigate gas leaks. Shut-in tests should be used to investigate gas leaks on piping in crawl spaces or attics.

2.0 Scope

[Section 3.0 – Target Audience](#)

[Section 4.0 - Definitions](#)

[Section 5.0 - Types of Confined Spaces](#)

[Section 6.0 – Atmospheric Measurements Prior to Entering a Confined Space](#)

[Section 7.0 - Identifying Other Hazards](#)

3.0 Target Audience

- Gas Engineers
- Gas Superintendents
- Gas Supervisors
- Gas Field Personnel

4.0 Definitions

UNCONTROLLED IF PRINTED

4.1 Confined Space:

- 4.1.1 A space large enough and configured so that an employee can bodily enter and perform assigned work; and
- 4.1.2 Has limited or restricted means for entry or exit; and
- 4.1.3 Is not designed for continuous employee occupancy.

4.2 Permit-Required Confined Space (PRCS):

- 4.2.1 Contains or has a potential to contain a hazardous environment that can not be made safe by means of ventilation.
 - 1. Items to check for include proper oxygen (O₂) content
 - 2. Presence of carbon monoxide (CO)
 - 3. Presence of natural gas.
- 4.2.2 Contains a material that has the potential for engulfing an entrant.
- 4.2.3 Has an internal configuration such that an entrant could be trapped or asphyxiated by inwardly converging walls or by a floor which slopes downward to a smaller cross-section.
- 4.2.4 Contains any other recognized serious safety and health hazard.

5.0 Types of Confined Spaces

5.1 The types of typical confined spaces a gas employee may be required to work in include:

- 5.1.1 Crawl Spaces
- 5.1.2 Attics
- 5.1.3 Vaults

6.0 Atmospheric Measurements Prior to Entering a Confined Space

6.1 Check Environment of Confined Space:

- 6.1.1 Check oxygen content (> 19.5 % < 23.5 %.)
- 6.1.2 The oxygen content of the confined space that is being tested should be in the range of 19.5% to 23.5%.
 - 1. If the oxygen content is not in this range, ventilation will be required until the 19.5% to 23.5% level is achieved.
 - 1 a. If, after ventilation, the proper oxygen level cannot be achieved, do not enter the confined space.
- 6.1.3 Check CO level (< 30 ppm)
- 6.1.4 The CO content of the confined space that is being tested should be less than 30 ppm.
 - 1. If the CO content is not less than 30 ppm, ventilation will be required.
 - 1 a. If, after ventilation, a CO level less than 30 ppm cannot be achieved, do not enter the confined space.
- 6.1.5 Check % gas in air (< 10% L.E.L).

6.1.6 The gas in air concentration of the confined space should be less than 10% L.E.L.

1. If the gas in air concentration is not less than 10% L.E.L., ventilation will be required.

1 a. If, after ventilation, a gas in air concentration of less than 10% L.E.L. cannot be achieved, do not enter the confined space.

6.1.7 While working in a confined space, the environment shall be constantly monitored. If at any time the environment falls outside the limits described in this policy, the confined space shall be immediately vacated.

7.0 Identifying Other Hazards

7.1 Excessive water or sewage in a confined space may present a hazard.

7.1.1 If the water/sewage cannot be removed, the confined space should not be entered.

7.2 Damaged electrical wires may cause a shock hazard.

7.2.1 If present the confined space should not be entered.

7.3 If, after the proper evaluation of the confined space, it is determined that no hazards exist, the confined space is safe for gas field personnel to enter.

End of Instructions

Operator Qualification (OQ) Required?

YES

1351: Vault Inspection and Maintenance

Appendices

NONE

Attachments

NONE

Compliance Requirements

NONE

Reference Documents

AIC Field Safety Manual, Section 35.0. Confined and Enclosed Spaces. Available on the AIC Safety SharePoint site.

Document Rescission

CONF 1 Confined Space: Requirements, October 1, 2021

Revision Notes

Location of Changes	Summary of Changes
---------------------	--------------------

UNCONTROLLED IF PRINTED

Not applicable.	Format of document has been changed to match the format of the October 1, 2022 issue.
1.0 Purpose	Added - Confined space entry requirements and procedures are regulated by the Occupational Safety and Health Administration (OSHA). Ameren Illinois (AIC) Safety Department is responsible for administering the OSHA regulations. AIC's Safety Supervisors should be contacted with any questions or concerns regarding confined spaces or confined space entry.
1.0 Purpose	Updated references – EXCV 2.9 Working in Hazardous Environment and VALT 2.1 Inspecting Vaults and Pits
5.0 Types of Confined Spaces	Added - Vaults

CORR-Corrosion Control

CORROSION CONTROL

October 1, 2022

CORR 0 Table of Contents

[CORR 1 Corrosion Control: Requirements](#)

Section 1.0 Purpose

Section 2.0 Scope

Section 3.0 Target Audience

Section 4.0 Cathodic Protection Requirements

Section 5.0 Cathodic Protection Monitoring

Section 6.0 Remedial Action for Sub-Standard or Abnormal Cathodic Readings

Section 7.0 Requirements for Cathodic Protection of New and Replacement Pipeline Facilities

Section 8.0 Cathodic Protection Structures

Section 9.0 External Corrosion Visual Inspection and Repair

Section 10.0 Internal Corrosion Inspection

Section 11.0 Test Stations

Section 12.0 Test Lead Connections

Section 13.0 Electrical Isolation

Section 14.0 Cathodically Unprotected Pipelines

Section 15.0 Atmospheric Corrosion

Section 16.0 Painting Pipeline Facilities

Section 17.0 Qualifications

Section 18.0 Records

Operator Qualification (OQ)

Appendices

Appendix A - Buried Pipe Examination Form

Appendix B - Corrosion and Steel Damage Evaluation Form

Attachments

Attachment 1 - ICC Final Order 05-0113

Compliance Requirements

Reference Documents

Document Rescission

UNCONTROLLED IF PRINTED

CORR 2.1 Corrosion Control: Cathodic Protection Design

Section 1.0 Purpose

Section 2.0 Scope

Section 3.0 Target Audience

Section 4.0 General

Section 5.0 CP Structures

Section 6.0 Electrical Isolation

Section 7.0 Insulating Points

Section 8.0 Insulating Materials

Operator Qualification (OQ)

Appendices

Appendix A - Insulation Kits for Flanges

Compliance Requirements

Reference Documents

Document Rescission

CORR 2.2 Corrosion Control: Anode Requirements and Installation

Section 1.0 Purpose

Section 2.0 Scope

Section 3.0 Target Audience

Section 4.0 General

Section 5.0 Anode Specifications

Section 6.0 Anode Requirements

Section 7.0 Anode Bank Installations

Operator Qualification (OQ)

Appendices

Appendix A - Anode Installations

Appendix B - Anode Test Station

Compliance Requirements

Reference Documents

Document Rescission

CORR 2.3 Corrosion Control: Coatings

Section 1.0 Purpose

Section 2.0 Scope

Section 3.0 Target Audience

Section 4.0 Approved Coatings

Section 5.0 Approved Hot Applied Tapes

Section 6.0 Approved Cold Applied Tapes

Section 7.0 Approved Field Applied Epoxy Coatings

Section 8.0 Approved Cold Applied Wax Tapes

Section 9.0 Moisture Cured Wrap

Section 10.0 Approved Paint Specification

Section 11.0 Coating Inspection

Section 12.0 Approved Epoxy Coating for Submerged Facilities

Operator Qualification (OQ)

Appendices

Appendix A - Approved Coating Types for Installations

Appendix B - Coating Repair

Appendix C - Approved Hot Applied Tapes

Appendix D - Approved Cold Applied Tapes

Appendix E - Approved Field Applied Epoxy Coatings

Appendix F - Applied Cold Wax Tapes

Appendix G - Moisture Cured Wrap

Appendix H - General Wrapping Instructions

Appendix I - Specific Coatings

Appendix J - Approved Paints for Pipeline Facility Coating

Appendix K - Coating Inspection

Appendix L - Protal Applications

Appendix M - Epoxy Coating for Submerged Facilities

Compliance Requirements

Reference Documents

Document Rescission

CORR 2.4 Corrosion Control: Corrosion Protection Criteria

Section 1.0 Purpose

Section 2.0 Scope

Section 3.0 Target Audience

Section 4.0 General

Section 5.0 CP Criteria

Section 6.0 IR Drop Measurement

Section 7.0 IR Drop Testing Methods

UNCONTROLLED IF PRINTED

Section 8.0 Conducting the IR Drop Survey

Section 9.0 Hydrogen Generation Under Coatings

Operator Qualification (OQ)

Appendices

Appendix A - Measuring Cathodic Protection Potentials

Compliance Requirements

Reference Documents

Document Rescission

CORR 2.5 Corrosion Control: CP System Troubleshooting

Section 1.0 Purpose

Section 2.0 Scope

Section 3.0 Target Audience

Section 4.0 General

Section 5.0 Information Needed to Maintain CP Systems

Section 6.0 General Troubleshooting Steps

Section 7.0 Equipment Needed

Section 8.0 Structure Limit Verification

Section 9.0 Performing Verification

Section 10.0 Structure Size

Section 11.0 Current Requirements

Section 12.0 Current Requirement Calculation

Section 13.0 Establishing Required Current

Section 14.0 Current Interrupters

Operator Qualification (OQ)

Compliance Requirements

Reference Documents

Document Rescission

CORR 2.6 Corrosion Control: AC Interference on Buried Pipelines and Stray Current

Section 1.0 Purpose

Section 2.0 Scope

Section 3.0 Target Audience

Section 4.0 General

Section 5.0 Types of AC Interference

Section 6.0 Investigating AC Voltages on Pipelines

UNCONTROLLED IF PRINTED

Section 7.0 Stray Current
Operator Qualification (OQ)
Compliance Requirements
Reference Documents
Document Rescission

CORR 2.7 Corrosion Control: Short Investigation and Clearing Shorted Pipelines

Section 1.0 Purpose
Section 2.0 Scope
Section 3.0 Target Audience
Section 4.0 General
Section 5.0 Localizing the Shorted Area
Section 6.0 Null Method
Section 7.0 Peak Method
Section 8.0 Parallel Mains
Section 9.0 Shorting Locating Tips
Section 10.0 Casings
Section 11.0 Isolated Services
Section 12.0 Clearing Shorted Pipelines
Operator Qualification (OQ)
Appendices
 Appendix A - Short Detection Diagrams
 Appendix B - Cased Crossing Monitoring
 Appendix C - Equipment
Compliance Requirements
Reference Documents
Document Rescission

CORR 2.8 Corrosion Control: Cathodic Protection Testing

Section 1.0 Purpose
Section 2.0 Scope
Section 3.0 Target Audience
Section 4.0 General
Section 5.0 Soil Resistivity Testing
Section 6.0 Monitor Galvanic Anode Bed Output
Section 7.0 Install and Maintain Mechanical Electrical Connections

UNCONTROLLED IF PRINTED

Section 8.0 Test Electrical Isolation Devices

Section 9.0 Test Points

Section 10.0 Bonds

Section 11.0 Cased Crossings

Section 12.0 Major Foreign Pipeline Crossing

Section 13.0 Test Point Verification

Operator Qualification (OQ)

Appendices

Appendix A - Cathodic Test Stations

Appendix B - Test Lead Wire Attachment

Appendix C - Equipment

Compliance Requirements

Reference Documents

Document Rescission

CORR 2.9 Corrosion Control: Evaluation of Corrosion

Section 1.0 Purpose

Section 2.0 Scope

Section 3.0 Target Audience

Section 4.0 General

Section 5.0 Distribution Piping (60 psig and Below)

Section 6.0 Transmission or High Pressure Distribution Piping (Over 60 psig)

Section 7.0 Allowable Pit Length Tables

Section 8.0 Pipe Pit Gauge

Section 9.0 Pipe Thickness Gauge

Operator Qualification (OQ)

Appendices

Appendix A - Flow Chart for Analytical Method

Appendix B - Maximum Allowable Pit Depth

Appendix C - Allowable Pit Length Tables

Compliance Requirements

Reference Documents

Document Rescission

CORR 2.10 Corrosion Control: Rectifier Maintenance and Troubleshooting

Section 1.0 Purpose

Section 2.0 Scope

UNCONTROLLED IF PRINTED

Section 3.0 Target Audience

Section 4.0 General

Section 5.0 Rectifier Maintenance

Section 6.0 Rectifier Troubleshooting

Operator Qualification (OQ)

Appendices

Appendix A - Rectifier Installation

Compliance Requirements

Reference Documents

Document Rescission

CORR 2.11 Corrosion Control: Records

Section 1.0 Purpose

Section 2.0 Scope

Section 3.0 Target Audience

Section 4.0 Construction Order Review Processes

Section 5.0 Additional Detail Information for Test Points

Section 6.0 Other Cathodic Protection Record Activities

Operator Qualification (OQ)

Appendices

Appendix A - Cathodic Protection Review Responsibility Table

Appendix B - Cathodic Protection Review Stamp

Appendix C - Cathodic Protection Design Checklist

Compliance Requirements

Reference Documents

Document Rescission

CORR 3 Corrosion Control: Forms and Reference Materials

Forms

References

Attachments

Document Rescission

End Table of Contents.

Document Rescission

CORR 0 Corrosion Control: Table of Contents, October 1, 2019.

UNCONTROLLED IF PRINTED

Revision Notes

Location of Changes	Summary of Changes
Not applicable.	This is a new document.

CORROSION CONTROL

April 1, 2023

CORR 1 Requirements

1.0 Purpose

This document provides the requirements for corrosion control and monitoring per 49 CFR Part 192 Subpart I, Subpart M, and [ICC Waiver #05-0113](#).

2.0 Scope

This document addresses the following:

[3.0 Target Audience](#)

[4.0 Cathodic Protection Requirements](#)

[5.0 Cathodic Protection Monitoring](#)

[6.0 Remedial Action for Sub-Standard or Abnormal Cathodic Readings](#)

[7.0 Requirements for Cathodic Protection of New and Replacement Pipeline Facilities](#)

[8.0 Cathodic Protection Structures](#)

[9.0 External Corrosion Visual Inspection and Repair](#)

[10.0 Internal Corrosion Inspection](#)

[11.0 Test Stations](#)

[12.0 Test Lead Connections](#)

[13.0 Electrical Isolation](#)

[14.0 Cathodically Unprotected Pipelines](#)

[15.0 Atmospheric Corrosion](#)

[16.0 Painting Pipeline Facilities](#)

[17.0 Qualifications](#)

[18.0 Records](#)

Appendices

[Appendix A - Buried Pipe Examination Form](#)

[Appendix B - Corrosion and Steel Damage Evaluation Form](#)

Attachments

[Attachment 1 - ICC Final Order 05-0113.](#)

3.0 Target Audience

- Gas Engineering
- Gas Tech Engineering (GTE)
- Corrosion Control Supervisor
- Corrosion Control Specialists
- Gas Construction Services Supervisors
- Gas Construction Contractor Supervisors
- Gas Construction Services Inspectors
- Gas Storage Engineering

UNCONTROLLED IF PRINTED

- Pipeline Integrity Management Personnel
- Gas Storage Field Supervisors
- Gas Field Personnel
- Gas Storage Field Operators
- Gas Supervisors

4.0 Cathodic Protection Requirements (Appendix D to Part 192)

- 4.1 The standard criteria for achieving adequate cathodic protection of underground piping shall include one or all of the following criteria:
- 4.1.1 A pipe to soil potential of -0.850 volts with CP applied, measured with reference to a saturated copper-copper sulfate half-cell on a cathodically protected facility.
 - 4.1.2 A polarized potential of -0.850 volts measured immediately after the interruption of all current sources with reference to a saturated copper-copper sulfate half-cell.
 - 4.1.3 A minimum of 100 millivolts polarization shift measured with reference to a saturated copper-copper sulfate half-cell.
- 4.2 Cathodic protection pipe to soil potentials are to be measured with a voltmeter having a minimum input impedance of 10 mega ohms and a copper-copper sulfate reference cell. See Figure 1 and Figure 2.



Figure 1 Voltmeter



Figure 2 Copper-copper Sulfate reference cell

5.0 Cathodic Protection Monitoring

- 5.1 Mains

5.1.1 Mains that are cathodically protected by anodes or a rectifier shall be monitored once each calendar year at an interval not exceeding 15 months. The test shall include a P/S reading.

5.2 Isolated Structures

5.2.1 Isolated structures that are cathodically protected shall be monitored on a sampling basis. At least 10% of the isolated structures in a community shall be monitored each year so that all services are tested in each 10 year period. The test shall include a P/S reading.

5.2.2 Isolated structures include:

1. Isolated service lines
2. Isolated distribution and transmission mains less than 100 feet
3. Isolated fittings

5.3 See Table 1 below for examples of how isolated structures are to be tested for each system or location.

Table 1 - Sample Testing Schedule of Isolated Structures

Community 1			Community 2				Community 3	
14 Structures	Year Read	Year Read	4 Structures	Year Read	Year Read	Year Read	10 Structures	Year Read
A	2010	2017	A	2010	2014	2018	A	2010
B	2010	2017	B	2011	2015	2019	B	2011
C	2011	2018	C	2012	2016	---	C	2012
D	2011	2018	D	2013	2017	---	D	2013
E	2012	2019	Community 2 has 4 isolated structures and at least 1 is read each year.				E	2014
F	2012	2019					F	2015
G	2013	---	Community 1 has 14 isolated structures and 2 structures are read each year because there are more than 10 services but less than 21 in the community.				G	2016
H	2013	---					H	2017
I	2014	---					I	2018
J	2014	---					J	2019
K	2015	---					Community 3 has 10 isolated structures and 1 structure is read each year.	
L	2015	---						
M	2016	---						
N	2016	---						

5.4 Critical Interference and Non-Critical Bonds

5.4.1 A critical interference bond whose failure would jeopardize the cathodic protection of a main shall be electrically checked 6 times per calendar year at an interval not exceeding 2-½ months. See 49 CFR §192.465(c).

5.4.2 Other bonds not critical to the cathodic protection of a main shall be electrically checked once each calendar year at an interval not exceeding 15 months. See 49 CFR §192.465(c).

5.4.3 The test shall include the current flow across the bond and a P/S reading.

5.5 Rectifiers

5.5.1 A rectifier system that is used for cathodic protection shall be inspected six (6) times per calendar year at an interval not exceeding 2-½ months. See 49 CFR §192.465(b).

5.5.2 Inspection shall include the current and voltage output of the rectifier and be recorded in Maximo.

5.5.3 Remotely monitoring of current and voltage output is an acceptable inspection method.

5.6 Casings

Cased crossings with plastic mains do not need to be monitored for electrical isolation.

5.6.1 Casings shall be electrically isolated from cathodically protected main, unless the casing is filled with dielectric filler.

5.6.2 Electrical isolation testing shall be completed once each calendar year not to exceed 15 months, unless the casing is filled with dielectric filler.

5.6.3 Casings with less than 25 mV difference between pipe-to-soil readings shall have an additional test for isolation performed and be reported to the Gas Supervisor for further analysis, unless the casing is filled with dielectric filler.

1. If the half-cell has to be moved to perform both potential tests, casings with less than 200 mV difference between the pipe-to-soil and casing-to-soil readings shall have at least one additional test performed and be reported to the Corrosion Supervisor for additional analysis.

5.6.4 If the casing is documented as shorted and is filled with dielectric filler, only a pipe-to-soil reading is required.

5.6.5 If a casing does not have a monitoring station or vent utilized for testing it is assumed to be shorted and a shorted casing leak survey shall be performed over the casing area until it can be tested for electrical isolation.

5.6.6 Frequencies for shorted casing leak surveys are as shown in Table 2.

Table 2. Shorted Casing Leak Survey Frequency

Facility	Location	Frequency
Transmission	Class 1 & 2 locations	Biannually
Transmission	Class 3 locations	Quarterly
Distribution or High Pressure Distribution	In Business Districts	Quarterly
Distribution or High Pressure Distribution	Outside Business Districts	Biannually

5.7 Stray Current Testing

A major pipeline is a pipeline or other structure protected with an impressed current system.

5.7.1 Each major pipeline crossing will be monitored annually not to exceed 15 months.

6.0 Remedial Action for Sub-Standard or Abnormal Cathodic Reading

When a deficient reading below Ameren Illinois' (AIC) requirements of -0.950 volt is reported in the Pipe Examination form within ClickMobile:

1. Maximo sends a report to the Corrosion Control Supervisor and Technician.
2. Two work orders are generated in ClickMobile for the technician to:
 - a. Follow-up on an Investigation
 - b. Take a Reread.
3. The required corrective measures will be identified, performed and entered in ClickMobile or scheduled.

AIC requirement of P/S reading of -0.950 volts is more restrictive than the -0.850 volts required by 49 CFR Part 192 Appendix D.

6.1 Corrective action for deficient or abnormal corrosion measurement conditions requiring are detailed in Table 3 below.

Table 3. Deficient or Abnormal Corrosion Measurements

Abnormal Condition	Remedial Action	Compliance Time
"On" Pipe-to-Soil measurements (P/S) less negative than -0.950 volts	Correct condition	Within 1 year
Rectifiers and critical interference bonds	Correct condition	Within 2 months
Discovered unmonitored steel mains meeting AIC P/S criteria	Add test points and record the potentials	Within 1 year
Discovered unmonitored steel mains that do not meet AIC P/S criteria	Create integrity leak survey in Maximo and perform two leak surveys	First survey - within 30 days of discovery.
		Second Survey - with 6 months not to exceed 7½ months.
	Cathodic protection	Within 30 days of the initial leak survey and completed within one (1) year.

7.0 Requirements for Cathodic Protection of New and Replacement Pipeline Facilities

- 7.1 The following new underground facilities shall be coated with an approved external coating and cathodically protected (see 49 CFR §192.455):
 - 7.1.1 Steel transmission lines
 - 7.1.2 Steel distribution lines
 - 7.1.3 Steel service lines
 - 7.1.4 Related pipeline facilities
- 7.2 Pipe coating shall be inspected prior to installation and steps taken to minimize damage to coating during and after installation. See 49 CFR §192.461 (c) & (d).
- 7.3 All new and replacement steel pipeline facilities shall have a measured cathodic protection level of -0.950 volts or more within 1 year after completion of construction. See 49 CFR §192.455 (a)(2).

Communicate with Gas Supervisor and/or Corrosion Control group any changes made to system that may affect cathodic protection of system.

- 7.4 Cathodic protection is not required for electrically isolated, metal alloy fittings in buried or submerged plastic pipelines if:
 - 7.4.1 Tests, investigation or experience shows that adequate corrosion control is provided by the alloy composition.
and
 - 7.4.2 The fitting is designed to prevent leakage caused by corrosion pitting.
 - 7.4.3 However, an electrically isolated metal alloy fitting installed in a buried or submerged plastic pipeline after January 22, 2019 that does not meet the above requirements shall be cathodically protected and maintained in accordance with AIC integrity management plan. See 49 CFR §192.455 (f) & (g).
 - 1. If there is a situation where a metal alloy *fitting is needed*, Corrosion Control personnel shall be notified *prior to installation*.
 - 2. Corrosion Control will determine:
 - 2 a. If fitting requires cathodic protection.
 - 2 b. The method of protection.
 - 2 c. The means to monitor the protection.
 - 3. Location of the metal alloy fitting should be entered on AIC electronic mapping system.

Ameren doesn't install metal alloy fittings in buried or submerged plastic services and mains. Existing fittings are legacy fittings.

8.0 Cathodic Protection Structures

A cathodic protection structure or cathodic protection system is an electrically continuous piece of pipe including all electrically continuous fittings monitored as a unit. A cathodic protection structure can be feet or miles in length.

- 8.1 Cathodic protection structures shall be established to provide a method for identifying, maintaining, and monitoring cathodic protection on sections of buried steel pipe. See [CORR 2.1](#) Corrosion Control: Cathodic Protection Design.
- 8.2 All new underground steel gas facilities shall be designated as an independent cathodic protection structure or become part of an existing cathodic protection structure.
- 8.3 Cathodic protection systems shall be designed to minimize stray current to other structures.

9.0 External Corrosion Visual Inspection and Repair

- 9.1 When any portion of a buried steel main or service is exposed, an examination of the exposed portion shall be conducted and recorded on the Buried Pipe Examination form within ClickMobile with the information retained in Maximo. See [Appendix A](#) for a sample Buried Pipe Examination form. See 49 CFR §192.459.

Pipe Examination forms are required when either steel or plastic mains or services are exposed.

- 9.1.1 Pipe exposed in washouts can be treated as an atmospheric inspection on pipeline patrol.
- 9.2 The condition of the coating shall be documented and when the surface of the pipe is exposed it shall be examined for evidence of external corrosion and a P/S reading taken. See [Section 6.0](#), Remedial Action for Sub-Standard or Abnormal Cathodic Reading.
 - 9.2.1 If there is evidence of corrosion, the surface of the pipe shall be investigated beyond the excavation to determine the extent of the corrosion requiring corrective action.
- 9.3 A steel main or service with localized corrosion pitting to a degree where leakage might result shall be replaced or repaired. See [REPR 1](#).
- 9.4 Distribution piping, with an MAOP of 60 PSIG or less, shall be repaired or replaced if it is found to have corrosion resulting in:
 - 9.4.1 A remaining wall thickness less than that required for the MAOP of the pipeline.
or
 - 9.4.2 A remaining wall thickness less than 30 percent of the nominal wall thickness.

Refer to [CORR 2.9](#) for procedures on evaluating corrosion on distribution piping with an MAOP of 60 PSIG or less. See 49 CFR §192.487.

- 9.5 Transmission or high-pressure distribution piping, with an MAOP greater than 60 PSIG, is found to have corrosion resulting in a remaining wall thickness less than that required for the MAOP of the pipeline shall be:
- 9.5.1 Repaired or replaced to restore the serviceability of the piping.
 - or
 - 9.5.2 The operating pressure reduced commensurate with the strength of the pipe based on actual remaining wall thickness.

Refer to [CORR 2.9](#) for procedures on evaluating corrosion on transmission or high-pressure distribution piping with an MAOP over 60 PSIG. See 49 CFR §192.485.

10.0 Internal Corrosion Inspection

- 10.1 All tapping coupons are to be inspected for evidence of internal corrosion and documented on the Buried Pipe Examination form within ClickMobile. See [Appendix A](#).
- 10.2 Sections of pipe abandoned or removed for any reason shall be inspected for evidence of internal corrosion.
- 10.3 If evidence of internal corrosion is found in any steel pipe contact, the Corrosion Control person for that operating area or qualified Gas Engineer.
- 10.4 Corrosion Control person or qualified Gas Engineer will complete a Corrosion and Steel Damage Evaluation form within ClickMobile. See [Appendix B](#).
- 10.5 Mains that transport corrosive gas shall be monitored for internal corrosion.
- 10.6 See Gas Storage O&M [Section GSIC](#) for Internal Corrosion Monitoring procedures in the gas storage fields.

11.0 Test Stations

- 11.1 The following shall be designated as structure cathodic protection test stations and shall be equipped to facilitate monitoring:
 - 11.1.1 All cased crossings (except those filled) to verify electrical isolation.
 - 11.1.2 All major foreign pipeline crossings will be tested for stray current. Those crossings under roads or bodies of water require special considerations for testing.
 - 11.1.3 Other test stations as required.

12.0 Test Lead Connection

- 12.1 Test lead connections to pipelines must be mechanically secure, electrically conductive, minimize stress concentrations on the pipe. See [CORR 2.8 Appendix B](#).
- 12.2 Test lead connections are to be coated with an approved coating. See [CORR 2.8 Appendix B](#).

13.0 Electrical Isolation

- 13.1 Electrical isolation between protected pipelines and other underground structures shall be installed and maintained to facilitate cathodic protection and prevent damage to the pipeline or other facilities.

- 13.2 Protected facilities shall be isolated from unprotected facilities.
- 13.3 Insulators shall not be installed in areas where a combustible environment is anticipated.
- 13.4 Acceptable insulating materials are specified in [CORR 2.1, Section 8.0](#).

14.0 Cathodically Unprotected Pipelines (49 CFR §192.465)

- 14.1 Once every 3 years at intervals not exceeding 39 months, unprotected pipelines will be reevaluated for active corrosion. See 49 CFR. §192.465.
- 14.2 The following factors should be considered when determining areas of active corrosion:
 - 14.2.1 Leak frequency
 - 14.2.2 Operating pressure
 - 14.2.3 Location of the piping
 - 14.2.4 Proximity of other structures and dwellings
 - 14.2.5 Gas venting characteristics of the area
- 14.3 Corrosion should be considered active if maintenance resulting from leak surveys does not control a condition that could become detrimental to public safety.
- 14.4 Area determined active - consider the following actions:
 - 14.4.1 Cathodically protect and/or coat the pipe.
 - 14.4.2 Replace with coated and cathodically protected steel pipe.
 - 14.4.3 Replace with plastic pipe.
 - 14.4.4 Abandonment of pipe.
- 14.5 Area determined not active - reevaluate within 3 years.

15.0 Atmospheric Corrosion (49 CFR §192.479)

Atmospheric corrosion is defined as actual loss of metal that results in pitting. Light surface oxidation of metal (rust) is not considered atmospheric corrosion. Facilities with light surface oxidation can be recorded as "Needs Paint" within ClickMobile.

- 15.1 All above ground portions of transmission lines and distribution mains and service lines shall be cleaned and coated with a material to prevent atmospheric corrosion. See 49 CFR §192.479.
- 15.2 All new above grade facilities must be coated with an approved coating within 1 year of construction.
- 15.3 Monitoring of Atmospheric Corrosion

Atmospheric corrosion monitoring frequency is set by ICC through Waiver 05-0113 to 49 CFR §§ 192.481 and 192.723. See [Attachment 1](#) for a copy of the waiver.

15.3.1 The following are inspected for atmospheric corrosion at least once each calendar year not to exceed 15 months:

1. Above grade transmission facilities including farm taps connected to transmission mains
2. Regulator stations
3. Odorizers
4. Above grade emergency valves
5. Exposed facilities of a Critical Area Patrol
6. Commercial or industrial gas meters sets that require annual pressure check verifications.
7. Commercial or industrial gas meters sets that require annual calibration of electronic pressure and/or temperate correcting devices.
8. Above grade Gas Storage Field facilities
 - 8 a. At locations where insulation is installed around gas piping, removable windows shall be cut in the insulation at locations where there is good expectation for moisture to collect.
 - 8 b. Inspection of the piping under these windows should be done in conjunction with the Storage Field leak surveys.
 - 8 c. Inspection shall be documented on a Storage Field Insulation Port Inspection Form which is maintained at the specific storage field.

15.3.2 The following are inspected for atmospheric corrosion at least one time every 4 calendar years not to exceed 51 months (see [Attachment 1](#) - Final Order 05-0113 for Waiver from 49 CFR §192.481):

1. Above grade high pressure distribution and distribution facilities associated with designated leak surveys.
2. Farm taps connected to high pressure distribution mains.
3. Residential gas meter sets.
4. Commercial or industrial gas meter sets operating at 7 inches water column, 0.25 psig, metering pressure.

15.3.3 Areas identified to have atmospheric contaminants that result in accelerated atmospheric corrosion shall be identified and inspected annually.

15.3.4 During the inspections, particular attention must be given to the pipe:

1. Soil-to-air interfaces
2. Under disbonded coatings.
3. Pipe supports

3a. Where preformed FRP spacers are present, pay attention to the presence of cracks in the epoxy or air gaps between the epoxy and the pipe.

3b. If rust stains are present, the spacer should be removed and the pipe inspected for corrosion.

4. Splash zones
5. Deck penetration
6. Spans over water

15.3.5 The results of the inspections should identify sites where there is:

1. Disbonded coating
2. Atmospheric corrosion
3. Pipeline facilities that need to be painted

15.4 Corrective Action

15.4.1 When atmospheric corrosion or disbonded coating is found, corrective action must be completed within 12 months.

15.4.2 Atmospheric corrosion or disbonded coating reported during compliance inspections shall be tracked in Maximo for corrective action.

15.5 Disbonded Coating at the Soil to Air Interface (factory applied coatings or field applied tapes)

15.5.1 Disbonded coatings reported at the soil to air interface on above ground pipeline facilities shall be recoated with approved materials.

15.5.2 To correct these pipeline facilities, the piping must first be cleaned to remove all loose coating, rust, and scale that may inhibit the adhesion of a newly applied coating.

15.5.3 Once cleaned and dry, the pipeline facilities shall be recoated with an approved coating found in [CORR 2.3](#).

15.6 Atmospheric corrosion reported on above ground pipeline facilities shall be recoated with approved materials.

See [CORR 2.7 Subsection 12.2](#) for additional measures to be taken when pipe is on pipe supports.

15.7 To correct these pipeline facilities, the piping and components must be cleaned to remove:

15.7.1 Oxidation

15.7.2 Surface rust

15.7.3 Grease

15.7.4 Oils

15.7.5 Other contaminants that might inhibit the ability of the coating to adhere to the metallic surface.

15.8 Atmospheric corrosion shall be inspected to ensure that the pit depth is:

UNCONTROLLED IF PRINTED

15.8.1 Not greater than 10% of the original wall thickness on transmission and high-pressure distribution pipeline facilities.

15.8.2 A wall thickness that's 70% of the original on distribution pipeline facilities.

15.9 This inspection will be documented on the Corrosion and Steel Damage Evaluation form within ClickMobile.

15.10 Once cleaned and inspected the pipeline facilities shall be coated with an approved coating. See [CORR 2.3](#).

16.0 Painting Pipeline Facilities (49 CFR §192.479)

16.1 New Facilities

16.1.1 All **uncoated** new above grade facilities **should** be **cleaned and** coated with an approved coating at the time of installation. If not possible, **Gas Supervisor or Operations Coordinator should schedule it to be done. See [CORR 2.3 Section 10.0](#) Approved Paint Specification and [Appendix J](#).**

16.2 Facilities Maintenance

16.2.1 Corrective action for above ground pipeline facilities that are reported as needing to be painted should be completed within the next calendar year.

16.2.2 Facilities needing paint reported during leak surveys shall be grouped by the survey ID and documented within ClickMobile for corrective action.

Maximo will maintain a list of facilities that need paint and tracking corrective actions by specific address or location.

Gas Supervisors can continue to use spreadsheets that list locations where deficiencies were discovered prior to December 1, 2014.

16.2.3 Annually, the Supervisor shall provide a summary report to the Manager, Gas Safety Compliance at the Pawnee Gas Training Center on facilities that need paint associated with leak surveys.

This is being done to support the reporting requirements of ICC Waiver #05-0113.

16.2.4 Above-ground pipeline facilities that are disassembled by AIC gas field personnel for maintenance activities such as a meter, regulator or valve change shall have the above-ground piping and components cleaned and painted.

16.2.5 Corrective action shall be taken while on site or documented within ClickMobile whenever gas field personnel are on site for other activities and identify:

1. Disbonded coating
2. Atmospheric corrosion

3. Pipeline facilities that need to be painted.

16.3 Painting of Facilities Exposed to the Atmosphere

16.3.1 When painting pipeline facilities, the piping and components must be cleaned to remove:

1. Loose paint
2. Surface rust
3. Grease
4. Oils
5. Dirt
6. Other contaminants that might inhibit the ability of the coating to adhere to the metallic surface.

16.3.2 Do not paint:

1. Meter index
2. Remote meter reading device
3. Meter badge
4. Name plate
5. Regulator data plates
6. Relief vent
7. Screens
8. Stainless steel control lines, fittings or valves

16.3.3 Once cleaned, the pipeline facilities shall be coated with approved coating in accordance with [CORR 2.3, Section 9.0](#).

1. When coating residential meter sets, up to 3 feet of customer piping may also be coated.

17.0 Qualifications

17.1 All corrosion activities including those for the design, installation, operation and maintenance of cathodic protection systems, must be carried out by, or under the direction of a person qualified in pipeline corrosion control methods.

AIC OQ program will form the basis for this qualification but other things such as external training, NACE certifications and years of experience will also be considered. See Operator Qualifications (OQ) required section at the end of this document.

18.0 Records

18.1 All cathodic protection (CP) records shall be maintained for the life of the facility.

18.2 All information shall be maintained in Maximo and the electronic mapping system.

18.3 Cathodic protection structure maps shall be created and maintained for all cathodically protected structures.

18.3.1 The maps shall include the location of:

1. Cathodically protected mains.
2. Electrical isolating devices.
3. Interference bonds with adjacent structures.
4. Anode bank.
5. Rectifiers and associated ground bed.
6. CP test points.
7. 5# and 17# anodes attached to CP structures.

NOTE:	Location of 5# anode connected to tracer wire for a PE main installation should be mapped
--------------	---

18.4 Cathodic protection monitoring records shall include each:

- 18.4.1 Test
- 18.4.2 Survey
- 18.4.3 Examination
and
- 18.4.4 Remedial action that is conducted

End of Instructions.

Operator Qualification (OQ) Required?

NO.

Appendices

[Appendix A - Sample Buried Pipe Examination Form](#)

[Appendix B - Corrosion and Steel Damage Evaluation Form](#)

Attachments

[Attachment 1 - ICC Final Order 05-0113.](#) (PDF file)

Compliance Requirements

49 CFR §192.455 External corrosion control: Buried or submerged pipelines installed after July 31, 1971.

49 CFR §192.459 External corrosion control: Examination of buried pipeline when exposed.

49 CFR §192.461 External corrosion control: Protective coating.

49 CFR §192.465 External corrosion control: Monitoring.

UNCONTROLLED IF PRINTED

49 CFR §192.479 Atmospheric corrosion control: General.

49 CFR §192.481 Atmospheric corrosion control: Monitoring.

49 CFR §192.723 Distribution systems: Leakage surveys.

Appendix D to Part 192 - Criteria for Cathodic Protection and Determination of Measurements

Reference Documents

[CORR 2.1 Corrosion Control: Cathodic Protection Design](#)

[CORR 2.3 Corrosion Control: Coatings](#)

[CORR 2.8 Corrosion Control: Cathodic Protection Testing](#)

[CORR 2.9 Corrosion Control: Evaluation of Corrosion](#)

Document Rescission

CORR 1 Corrosion Control: Requirements, October 1, 2022

Revision Notes

Location of Changes	Summary of Changes
Subsection 16.1 – Painting Pipeline Facilities	Revised – All uncoated new above grade facilities should be cleaned and coated with an approved coating at the time of installation. If not possible, Gas Supervisor or Operations Coordinator should schedule it to be done. See CORR 2.3 Section 10.0 Approved Paint Specification and Appendix J.
Appendix A-2 Buried Pipe Examination Form	Added – Pipe installed in a vault or pit to the list of examples of when Buried Pipe Examination should not be performed.

Appendix A - Buried Pipe Examination Form

A-1. Sample Buried Pipe Examination Form

A-2. Completion of Buried Pipe Examination Form

1. Buried Pipe Examination

- A. The Buried Pipe Examination shall be completed by gas field personnel or Damage Prevention's Watch and Protect personnel, construction inspectors, engineering personnel, or others any time existing buried plastic or steel gas carrying pipe is exposed by an excavation.
- B. An examination of the exposed portion must be conducted and recorded on the Buried Pipe Examination form within ClickMobile.
- C. A Buried Pipe Examination form shall be completed within ClickMobile any time existing main or service pipe, plastic or steel, is exposed and the existing pipe is planned to remain in service.
- D. A Buried Pipe Examination form is required for each pipe segment and should be completed within ClickMobile.
- E. If the examination of the pipe indicates the presence of corrosion or damage to the pipe, then a Corrosion and Steel Damage Form should be completed within ClickMobile.
- F. A Buried Pipe Examination form *should not be performed* when:
 - (1) New pipe being installed.
 - (2) The exposed pipe is found during a pipeline or critical area patrol. However, the exposed pipe should be reported to the Gas Supervisor for a follow-up inspection.
 - (3) **Reminder:**
 - a) A Pipe Examination *should not be performed* on retired pipe, retired sections of pipe or facilities.
 - b) Do not enter pipe-to-soil readings on Pipe Examination:

- For pipe classified as Unprotected Main.
 - On a rectified protected pipe when the rectifier is turned off.
 - Field Engineering Representatives
 - When an active replacement project will retire the existing section of pipe within the next twelve (12) months. If the pipe coating is not disturbed.
- c) When an anode has been installed, do not take pipe-to-soil reading until the anode has been activated if possible.
- (4) **Pipe located in a vault or pit.**
- G. The following list identifies the most common instances when a Buried Pipe Examination form should be completed:
- (1) **Replacement** of a gas service or main - partial or total replacements - the form should be completed for any exposed existing pipe that will remain in service after the DOJM/WO project has been finalized. This typically will be the main or the service at the tie-in point.
 - (2) **Relocation** of a gas service or main - the form should be completed for the exposed existing pipe that will remain in service after the DOJM/WO project has been finalized. This typically will be the main or the service at the tie-in point
 - (3) **Leak Repair** of a gas service or main - the form should be completed for the exposed existing pipe that will remain in service after the job has been finished.
 - (4) **Installation of a gas service or main** - the form should be completed for the exposed existing pipe that will remain in service after the DOJM/WO project has been finalized. For new construction, this is typically the main or service at the tie-in point.
 - (5) **Retirement of a gas main or service** - the form should be filled out for:
 - The main remaining in service after the retirement
 - The main and service stub after the service line has been abandoned
 - If there is bare metal exposed on the steel main or if a steel service off the steel main is retired, a pipe-to-soil potential shall be taken on either the main remaining in service or on the steel service stub.
 - For pipe classified as Unprotected Main.
 - On a rectified protected pipe when the rectifier is turned off.
 - If the pipe coating is not disturbed.
 - When an active replacement project will retire the existing section of pipe within the next twelve (12) months.
 - (6) **Stand-by** for third party excavation when existing gas pipe is exposed.
- H. The internal surface of the abandoned pipe must be inspected for evidence of corrosion as stated in this document. A corrosion control person for the area should be notified if there is an indication of internal corrosion. Any internal corrosion found will be documented on a Corrosion and Steel Damage Evaluation with-

in ClickMobile stating where the internal corrosion was found; on the pipe remaining in service or the abandoned pipe.

Note: If a corrosion control person or qualified gas engineer is not available at time of discovery, a representative section of the pipe with internal corrosion can be removed and retained for evaluation.

- I. Information from Buried Pipe Examination forms is maintained in Maximo.
 - J. Information will be used by Corrosion, Operations, Engineering, Corrosion Control, DIMP, and TIMP personnel for evaluation, maintenance and risk analysis.
2. *Distribution*
- A. Buried Pipe Examination will be completed within ClickMobile. The information will be maintained in Maximo. Refer to [CORR 2.2 Section 4.8](#) - Anode Requirements if the Buried Pipe Examination is being completed following the installation of an anode and the pipe-to-soil reading is still deficient.
 - B. Maximo will generate a Task and send it to Corrosion Control, Gas Tech Engineering or the Pipeline Integrity Group when corrective action is required. Maximo will track and maintain corrective action taken.
3. *Completion Instructions*
- A. The Buried Pipe Examination Form will be completed within ClickMobile.
 - B. The required information field are indicated in Red. However, it is good practice to record all information that is known.
 - C. It is important that the accurate pipe information be entered in ClickMobile:
4. *Records*
- A. Information from Buried Pipe Examination forms is maintained in Maximo.
 - B. Maximo tracks and maintains corrective action taken and reported within ClickMobile.
 - C. Tasks and queries can be generated and submitted to the appropriate work groups.

Appendix B - Corrosion and Steel Damage Evaluation Form

B-1. Sample Corrosion and Steel Damage Evaluation Form

The screenshot shows a web-based form titled "Corrosion and Steel Damage Evaluation". The form is divided into several sections: Location Information, Pipe Information, Corrosion Evaluation, Steel Damage Evaluation, Action Taken, and Work Order Follow Thru. Red callout boxes provide the following instructions:

- "This is the original exam database number and will be the same." (points to the Exam Database Number field)
- "Enter information exactly as it is filled out on hard copy." (points to the Location Information section)
- "Pitting" or "No Pitting" must be selected before evaluation is saved." (points to the Corrosion Type dropdown)
- Do not "Create New Pitting" or "Create New Damage" until all other fields are filled out and evaluation is saved." (points to the "Create New Pitting" and "Create New Damage" buttons)
- Save evaluation after page is filled out but before entering pitting and damage info and before leaving the page." (points to the "Save Evaluation" button)
- Evaluation Database System Number will be provided after exam is saved. This number is written in the bottom right corner of evaluation hard copy." (points to the Evaluation Database System Number field)
- Employee ID is automatically displayed (points to the Employee ID field)
- Refreshes info and changes on screen." (points to the Refresh button)
- This button directs you back to the home page (the search page). This button does not save changes." (points to the "Go Home Without Saving" button)
- This button directs back to original buried pipe examination page." (points to the "Go to Buried Pipe" button)
- This button clears form." (points to the Clear button)
- Fill this section out when outstanding issue is complete." (points to the Work Order Follow Thru section)

B-2. Completion of Corrosion and Steel Damage Evaluation Form

1. General

- A. This form is to be used to record evaluations performed on steel pipe for corrosion or pipe damage found in the field as well as documents and tracks corrective actions taken.
- B. Corrosion and Steel Damage Evaluation will be completed by individuals designated by the Company as being qualified to evaluate steel pipe damage and/or corrosion. This may include Corrosion Control personnel, Gas Engineers, Gas field personnel, IMP personnel or others.
- C. Gas field personnel are responsible for completing a Corrosion and Steel Damage form, when required, on distribution pipe.
- D. Corrosion Control personnel, Gas Engineer, or other qualified personnel designated by the Company will be responsible for completing a Corrosion and Steel Damage Evaluation form on transmission or high pressure distribution pipe.

2. Distribution

- A. Corrosion and Steel Damage Evaluation form will be completed within ClickMobile. The information will be transferred and maintained in Maximo.
- B. Maximo will generate a Task and send it to Corrosion Control when corrective action is required. Maximo will track and maintain corrective action taken.

3. Completion Instructions

- A. The Corrosion and Steel Damage Evaluation Form will be completed within Click-Mobile.

- B. The required information field are indicated in **Red**. However, it is good practice to record all information that is known.
- C. It is important that accurate pipe information be entered in ClickMobile.

4. *Records*

- A. Information from Corrosion and Steel Damage Evaluation forms is maintained in Maximo.
- B. Maximo tracks and maintains corrective action taken and reported within Click-Mobile.
- C. Tasks and queries can be generated and submitted to the appropriate work groups.

CORROSION CONTROL

October 1, 2022

CORR 2.1 Cathodic Protection Design

1.0 Purpose

This document provides the requirements for cathodic protection design in compliance with 49 CFR §§ 192.467, 192.469, 192.471, and 192.473.

2.0 Scope

This document addresses the following:

[3.0 Target Audience](#)

[4.0 General](#)

[5.0 CP Structures](#)

[6.0 Electrical Isolation](#)

[7.0 Insulating Points](#)

[8.0 Insulating Materials](#)

Appendices:

[Appendix A - Insulation Kits for Flanges](#)

3.0 Target Audience

- Gas Engineering
- Gas Tech Engineering (GTE)
- Corrosion Control Supervisor
- Corrosion Control Specialists
- Pipeline Integrity Management Personnel
- Gas Field Personnel
- Gas Supervisors
- Gas Construction Services Supervisors
- Gas Construction Contractor Supervisors
- Gas Construction Services Inspectors
- Gas Storage Engineering
- Gas Storage Field Supervisors
- Gas Storage Field Operators

4.0 General

- 4.1 Whenever a steel main is involved in a gas project, cathodic protection design must be accounted for in the final project design. Examples include:
- 4.1.1 Extending a new plastic main from an existing steel main.
 - 4.1.2 Installing a new station for a new plastic distribution system.
 - 4.1.3 Replacing sections of steel distribution pipe to facilitate road or other facility construction.
 - 4.1.4 Relocating existing steel main with new steel.
 - 4.1.5 Installing a new steel pipeline.
 - 4.1.6 Extending new steel main from an existing steel main.
- 4.2 Consult with the person responsible for cathodic protection in the Region where the work is being performed prior to finalizing the design.

UNCONTROLLED IF PRINTED

5.0 CP Structures

- 5.1 Cathodic protection structures provide a method for identifying, maintaining, and monitoring corrosion protection on sections of buried steel piping.
- 5.2 A cathodic protection structure is the buried pipeline section which includes:
 - 5.2.1 Electrically continuous welded or bonded sections of pipeline.
 - 5.2.2 Isolated from unprotected structures or other structures not designated as a part of the intended structure.
 - 5.2.3 Pipe protected by either magnesium anodes and/or an impressed current system.

The plastic piping systems currently installed have no steel gas carrying components (plastic main, service tubing, and casing style risers). For tracing purposes, these systems are buried with tracer wire, and the pipe does not need to be designated as part of any cathodic protection structure.

- 5.3 Consult the person responsible for cathodic protection in the Region where the work is being performed when installing the following to determine whether insulation is required:
 - 5.3.1 Emergency valves.
 - 5.3.2 Lowering steel main.
 - 5.3.3 Rerouting steel main.

6.0 Electrical Isolation

- 6.1 Obtaining Electrical Isolation
 - 6.1.1 Electrical isolation is obtained by using insulating devices and maintaining proper clearance to foreign utilities.
 - 6.1.2 An insulating device may not be installed in an area where a combustible atmosphere is anticipated unless precautions are taken to prevent arcing.
 - 6.1.3 Solid State Decouplers (SSD)(stock code 40 89 716) installation can be considered where lightning and voltage surges are anticipated. See [CORR 2.6](#) and Figure 1.



Figure 1. Solid State Decouplers (SSD)

6.1.4 SSDs should be used across insulation points inside buildings where a combustible environment is anticipated.

6.2 Maintaining Electrical Isolation

6.2.1 Electrical isolation is required:

1. Between a cathodically protected pipeline and other underground structures unless protected as a single unit.
2. Between a cathodically protected pipeline and a casing unless the casing is filled with a dielectric material.
3. Where necessary to facilitate cathodic protection.

7.0 Insulating Points

7.1 Insulation shall be provided in accordance with Table 1.

Table 1. Insulation Requirements

New Steel Mains	Insulate from	Unprotected steel
New Steel Services	Insulate from	Unprotected steel and Customer piping
Existing Protected Steel Mains	Insulate from	Unprotected steel
Existing Protected Steel Services	Insulate from	Customer piping

Avoid installing insulators inside buildings unless lightning protection is used or a combustible environment is not anticipated.

7.2 Typical insulating points include the following:

7.2.1 All customer meters.

7.2.2 Pressure control stations when required.

UNCONTROLLED IF PRINTED

7.2.3 Valves when required.

7.3 Insulating Regulator Stations

7.3.1 The following diagrams illustrate typical situations where insulation and bonding may be required.

1. Distribution Station (New Plastic Outlet System). See Figure 2.

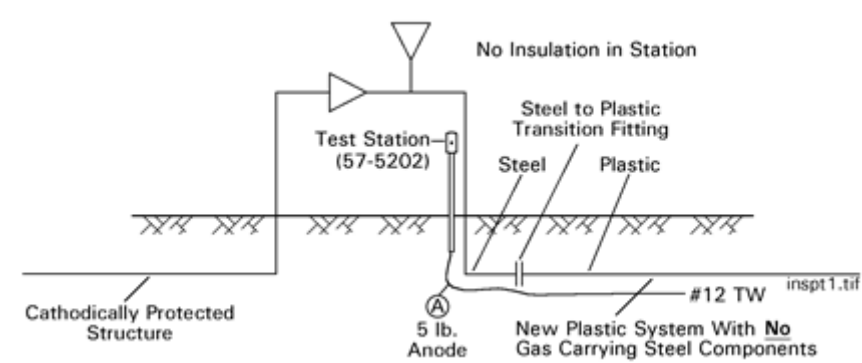

Figure 2. Distribution Station - New Plastic Outlet System

2. Large Distribution Station or Town Border Station with Steel Outlet System. See Figure 3.

- 2 a. Consult with Corrosion Control personnel to determine if a Lightning Arrestor needs to be installed.

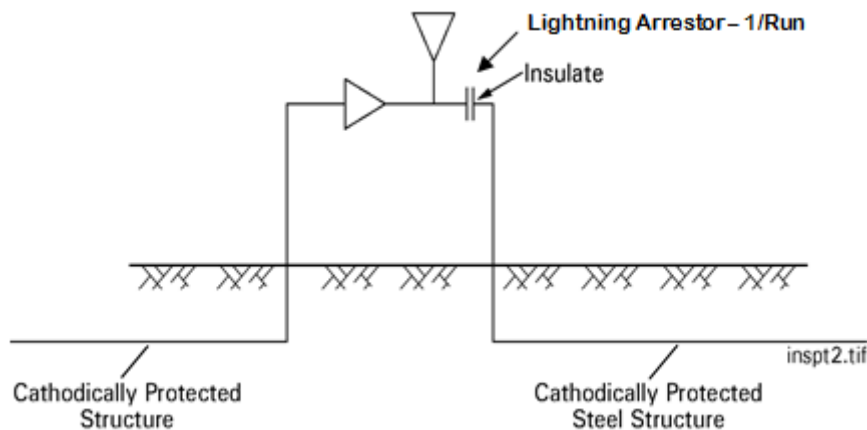

Figure 3. Large Distribution Station or Town Border Station with Steel Outlet System

3. Delivery Station. See Figure 4.

- 3 a. Consult with Corrosion Control personnel to determine if a Lightning Arrestor needs to be installed.

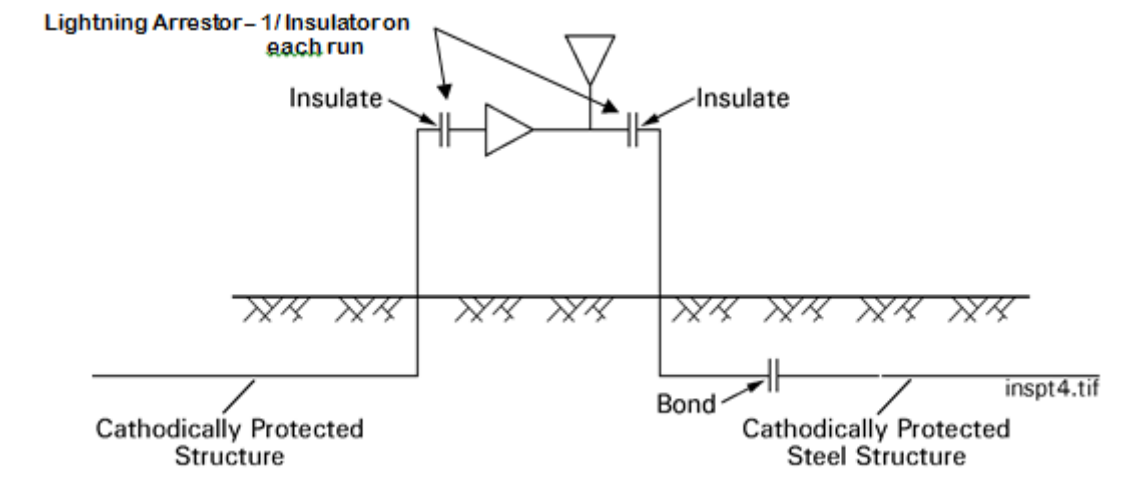

Figure 4. Delivery Station

7.4 Bonding

7.4.1 Extending New Steel from Existing Steel. See Figure 5.

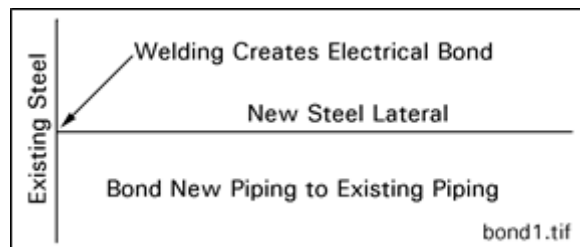

Figure 5. Extending New Steel from Existing Steel.

7.4.2 Creating a System Loop - Steel. See Figure 6.

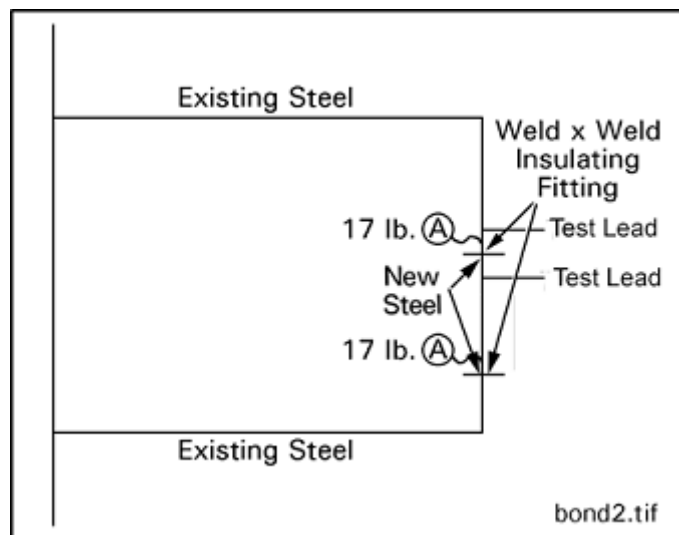

Figure 6. Steel System Loop

Do not create electrically continuous piping loops. Install insulation points in any loop created.

7.4.3 Extending New Plastic Lateral from Existing Steel. See Figure 8.

UNCONTROLLED IF PRINTED

1. Consideration shall be taken for attaching and bringing a #8 wire off of the steel pipe to identify it separately from the #12 tracer wire that is installed with the PE main.

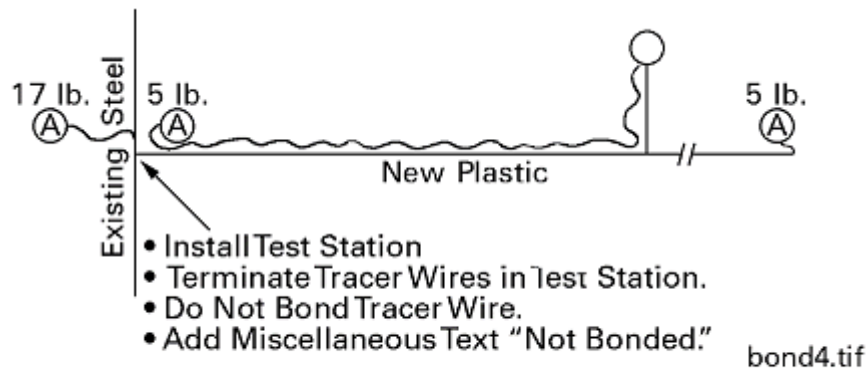

Figure 8. Extending New Plastic Lateral from Existing Steel.

7.4.4 Extending New Plastic from End of Existing Steel. See Figure 9.

1. Consideration shall be taken for attaching and bringing a #8 wire off of the steel pipe to identify it separately from the #12 tracer wire that is installed with the PE main.

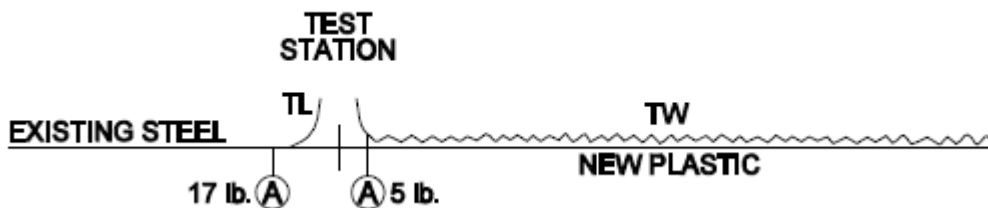

Figure 9. Extending New Plastic from End of Existing Steel.

7.4.5 New Plastic Installed Between Two Sections of Existing Steel. See Figure 10.

1. Consideration shall be taken for attaching and bringing a #8 wire off of the steel pipe to identify it separately from the #12 tracer wire that is installed with the PE main.
2. The use of plastic pipe between two sections of steel shall be reviewed by engineering and corrosion control personnel. Consideration should be given to using steel pipe.

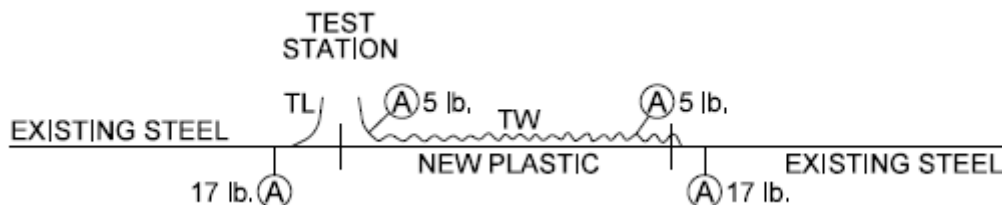

Figure 10. New Plastic Installed Between Two Sections of Existing Steel

7.4.6 Relocating Existing Steel with Plastic. See Figure 11.

1. Consideration should be taken for attaching and bringing a #8 wire off of the steel pipe to identify it separately from the #12 tracer wire that is installed with the PE main.

2. The use of plastic pipe between two sections of steel should be reviewed by engineering and corrosion control personnel. Consideration should be given to using steel pipe.

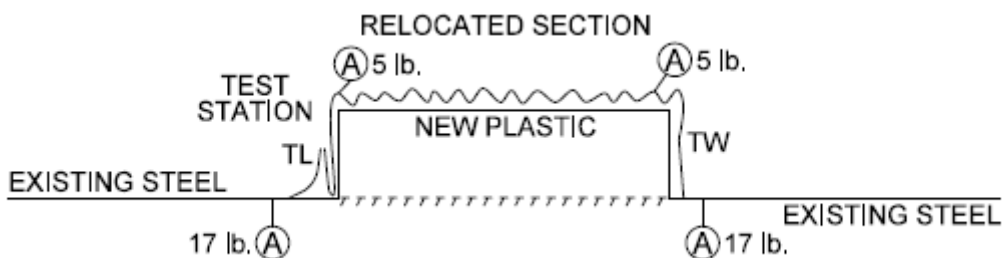

Figure 11. Relocating Existing Steel with Plastic

8.0 Insulating Materials

8.1 Stainless Steel Tubing Insulators

Stainless steel tubing insulators can be used to insulate control lines within pressure control stations and at other locations. See Table 2 and Figure 12.

Dielectric Tubing Stainless Steel Fittings	
Tubing Size	Stock No.
1/4"	19 66 164
3/8"	19 66 147
1/2"	19 66 168

Table 2. Stainless Steel Tubing Insulators

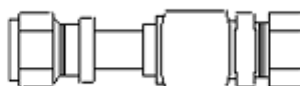

Figure 12. Stainless Tubing Insulator

8.2 Flange Insulation

8.2.1 Flange insulation is recommended for above ground flange joints. See [Appendix A](#) Insulation Kits for Flanges.

1. Flange insulation is not recommended for underground installations.

Double-bolt insulators are recommended for all new or replacement flange insulating kits. See Figure 13.

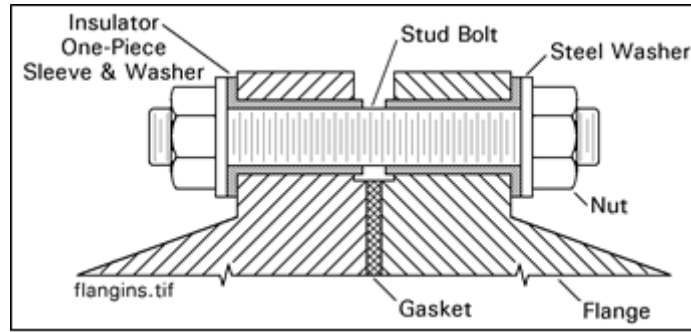

Figure 13. Double-bolt Insulators

8.3 Weld End Insulators

8.3.1 Weld End Insulators can be used in new construction or existing pipelines and are recommended for underground installations. See [STLP 3.1](#) for weld end insulators.

8.4 Insulator Unions

8.4.1 Insulating Unions can be used in pressure control stations, meter sets or other installations where electrical isolation of threaded pipe is required. See Table 3 for approved insulating unions.

Table 3. Insulating Unions

Size	Class 150	Class 3000
3/4"	19 73 066	19 73 941
1"	19 73 069	19 73 948
1 1/4"	19 62 454	19 73 951
2"	19 73 072	49 22 403

Table 4. Pressure – Temperature Ratings

Pressure – Temperature ratings for Class 150 Malleable Iron Threaded Fittings (psi)		
-20°F - 150°F	200°F	250°F
300	265	225

End of Instructions.

Operator Qualification (OQ) Required?

NO.

Appendices

UNCONTROLLED IF PRINTED

[Appendix A - Insulation Kits for Flanges](#)

Attachments

NONE.

Compliance Requirements

- 49 CFR §192.467 External corrosion control: Electrical.
- 49 CFR §192.469 External corrosion control: Test stations.
- 49 CFR §192.471 External corrosion control: Test stations.
- 49 CFR §192.473 External corrosion control: Interference currents.

Reference Documents

[CORR 2.6 Corrosion Control: AC Interference on Buried Pipelines and Stray Current](#)

[STLP 3.1 Steel Pipe: Weld Fittings](#)

Document Rescission

CORR 2.1 Corrosion Control: Cathodic Protection Design, May 15, 2022

Revision Notes

Location of Changes	Summary of Changes
Paragraph 8.4.1 – Insulator Unions	Table 3 – Revised column headings to Class 150 and Class 3000. Corrected Stock Code for 1-1/4" Class 150 Insulating Union
Paragraph 8.4.1 – Insulator Unions	Added Table 4 Pressure – Temperature Ratings Malleable insulator union's pressure rating is temperature sensitive.

Appendix A - Insulation Kits for Flanges

A-1. Insulation Kit for Class 150 Flanges

Insulation Kit for Class 150 Flanges				
Size	Flat-Faced Flange (Complete Kit)	Raised Face Flange (Complete Kit)	One-Piece Sleeve & Washer Only	Gasket Only Flat-Faced Flange
1 1/4"	24 57 665	24 57 689		29 51 932
2"	24 57 666	24 57 690	49 22 198	29 51 933
3"	24 57 667	24 57 691	49 22 406	29 51 934
4"	24 57 668	24 57 692		29 51 935
6"	24 57 669	24 57 693		29 51 936
8"	24 57 670	24 57 694		29 51 937

UNCONTROLLED IF PRINTED

10"	24 57 671	24 57 695	49 22 203	29 51 938
12"	24 57 672	24 57 696	49 22 204	29 51 939

A-2. Insulation Kit for Class 300 Flanges

Insulation Kit for Class 300 Flanges			
Size	Raised Face Flange (Complete Kit)	One-Piece Sleeve & Washer Only	Gasket Only Raised Face Flange
1 1/4"	24 57 673	49 22 205	29 64 857
2"	24 57 674	49 22 206	
3"	24 57 675	49 22 207	
4"	24 57 676	49 22 208	29 51 940
6"	24 57 677	49 22 209	29 64 860
8"	24 57 678	49 22 210	29 64 861
10"	24 57 679	49 22 467	29 64 862
12"	24 57 680	49 22 211	29 64 863

A-3. Insulation Kit for Class 600 Flanges

Insulation Kit for Class 600 Flanges			
Size	Raised Face Flange (Complete Kit)	One-Piece Sleeve & Washer Only	Gasket Only Raised Face Flange
1 1/4"	24 57 681	49 22 212	
2"	24 57 682	49 22 213	29 64 858
3"		49 22 214	29 64 859
4"	24 57 684	49 22 215	29 64 864
6"	24 57 685	49 22 216	29 64 865
8"	24 57 686		29 64 866
10"	24 57 687	49 22 218	29 64 867
12"	24 57 688		29 64 868

CORROSION CONTROL

April 1, 2021

CORR 2.2 Anode Requirements and Installation

1.0 Purpose

This document provides the requirements for anode installations and record per 49 CFR Part 192 Subpart I.

2.0 Scope

This document addresses the following:

[3.0 Target Audience](#)

[4.0 General](#)

[5.0 Anode Specifications](#)

[6.0 Anode Requirements](#)

[7.0 Anode Bank Installations](#)

Appendices:

[Appendix A - Anode Installations](#)

[Appendix B - Anode Test Stations](#)

3.0 Target Audience

- Gas Engineering
- Gas Tech Engineering (GTE)
- Corrosion Control Supervisor
- Corrosion Control Specialists
- Pipeline Integrity Management Personnel
- Gas Field Personnel
- Gas Supervisors
- Gas Construction Services Supervisors
- Gas Construction Contractor Supervisors
- Gas Construction Services Inspectors
- Gas Storage Engineering
- Gas Storage Field Supervisors
- Gas Storage Field Operators

4.0 General

- 4.1 Galvanic anodes may be installed individually, in pairs, or in banks of 5.
- 4.2 When 5 or more anodes are required on new construction or replacement of existing systems, anode banks shall be used in place of individual anodes.
- 4.3 Anode banks may be placed perpendicular or parallel to the gas main. See Appendix [A-2](#) Parallel Bank and [A-3](#) Perpendicular Bank.
- 4.4 Anode can be placed vertically or horizontally and a minimum of 6 inches below the bottom of the steel pipe. See Figures [1](#) and [2](#) for typical vertical and horizontal installations.
 - 4.4.1 Anodes may be installed in multiple groupings.
 - 4.4.2 No more than 2 anodes shall be installed in an excavation unless 10 feet of spacing can be maintained between the anodes.

UNCONTROLLED IF PRINTED

- 4.4.3 If multiple connections are made on the pipe, the connections should be at least 6 inches apart.

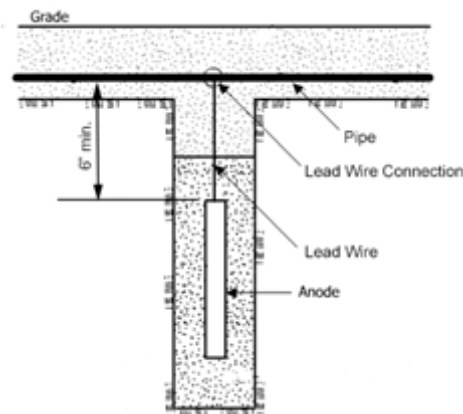

Figure 1. Typical Vertical Installation

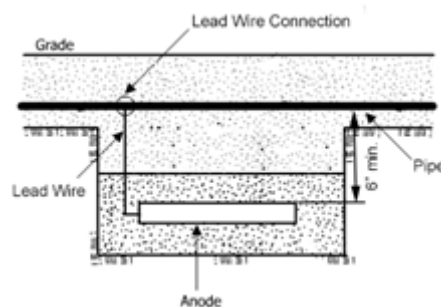

Figure 2. Typical Horizontal Installation

- 4.5 Install 17 lb. anodes in the main piping to protect coated steel systems not protected by a rectifier.
- 4.6 Anode should be placed as far away from the pipe as the excavation safely allows up to the length of the anode lead wire.
- 4.7 When the addition of an anode(s) is necessary, the Pipe to Soil (P/S) reading needs to be taken after the anode is activated.
- 4.7.1 If the P/S reading on the pipe does not increase immediately after attaching the anode(s), add water and allow time for the anode to activate.

When installing anodes, it is advisable to take water to the jobsite to wet the anode.

- 4.8 If after activation, the P/S reading is below -0.950 volts (more positive such as -0.900 volts), contact the Corrosion Control personnel for your area before backfilling the anode and entering the deficient reading in the Pipe Examination form within ClickMobile.

Anode life is expected to be 20 years or more on magnesium anode systems.

4.9 All anodes installed on mains shall be mapped in Ameren’s electronic system. Refer to 49 CFR §192.491.

5.0 Anode Specifications

5.1 See Figure 3 for a diagram of AIC approved anode and Table 1 for stock codes of AIC approved anodes.

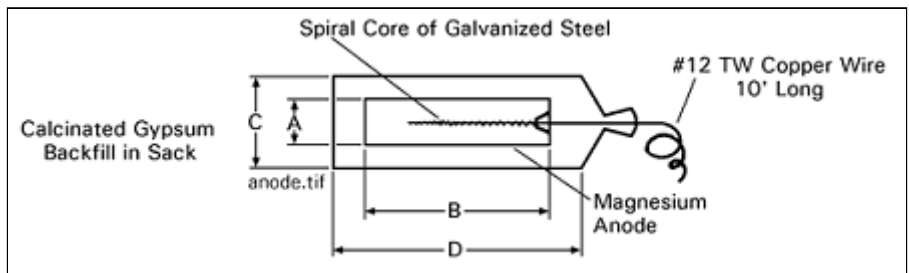

Figure 3 AIC Approved Anode

Table 1. Stock Codes for AIC Approved Anodes

Stock No.	Description
62 05 082	Anode, Magnesium, 5 lb., Packaged, with #12 TW Wire
62 05 058	Anode, Magnesium, High Potential, 17 lb., Packaged, with #12 TW Wire
62 05 067	Anode, Magnesium, 32 lb., Packaged, with #12 TW Wire
62 05 069	Anode, magnesium, 1 ½ lb., drivable, with #12 TW wire

6.0 Anode Requirements

6.1 Anodes shall be installed in accordance with the Tables 2, 3, 4, and 5 unless an actual field current test has been performed.

Do not install anodes on rectified systems unless recommended by Gas Operations and Services - Corrosion Control Group.

Table 2. New Steel Mains

Pipe Size		Length
1 ¼"	Install one 17 lb. anode per	1,500' of main
2"	Install one 17 lb. anode per	1,200' of main
3"	Install one 17 lb. anode per	1,100' of main
4"	Install one 17 lb. anode per	1,000' of main
6"	Install one 17 lb. anode per	800' of main
8"	Install one 17 lb. anode per	700' of main
10"	Install one 17 lb. anode per	500' of main

UNCONTROLLED IF PRINTED

12"	Install one 17 lb. anode per	450' of main
14"	Install one 17 lb. anode per	400' of main
16"	Install one 17 lb. anode per	350' of main
18"	Install one 17 lb. anode per	300' of main

To determine the number of anodes to be installed, divide the total number of feet of main by the length of main per anode corresponding to the pipe size from the table above. An allowance has been made for connected service lines.

Example: How many 17 lb. anodes are required for 5000 ft. of new 6 in. coated steel pipe?

$5000\text{ft.} / 800 = 6.25$ or 7 anodes required

Table 3. Service lines, repaired steel mains and services

	Pipe-to-Soil equal to or more negative than -1.00 V (ex. -1.25V)	Pipe-to-Soil less negative than -1.00 V (ex. -0.850V)
New Service Line - Steel	No Anode needed	Install anode
Repairs on Steel Mains or Services	No Anode needed	Install anode unless it is a transmission main

Table 4. Isolated risers

Plastic Service Riser	Install 1½ lb. drivable anode when isolated steel riser is a gas carrier. No anode is necessary on anodeless risers (self-protected).
-----------------------	---

Table 5. Isolated services

Existing Isolated Service Lines	Pipe-to-Soil reading less negative than -0.950 V - Install an anode
New Isolated Service Lines	Install a 5 lb. anode on isolated ¾" steel service lines. Install a 17 lb. anode on 1" and larger steel isolated service lines.

7.0 Anode Bank Installations

- 7.1 When choosing bank sites, give consideration to the geometry and current requirements of the system to be protected.
- 7.2 Review plans and confirm location with Corrosion Control person for the area.
- 7.3 Make sure cathodic protection shorts are eliminated.
- 7.4 Determine anodes required, and install anode bank(s). See [Section 6.0](#) for anode bank requirement.
- 7.5 Measure current drain on connector cable (main +) and recheck pipe-to-soil potentials with anodes connected (wait until anodes are activated).

UNCONTROLLED IF PRINTED

- 7.5.1 If system is below design potential, perform a new current requirement test with anodes connected.
- 7.6 With the current on, measure the anode current drain and use this value to calculate the number of additional anodes required.
- 7.7 For maximum anode bank efficiency, install 17 lb. anodes in groups of up to 5.
- 7.8 Where possible, place the anode bank perpendicular to system being protected. See [Appendix A-3](#) - Perpendicular Anode Bank.
 - 7.8.1 Maintain 10 feet minimum clearance from any buried foreign metallic system.

An alley with no buried facilities is an excellent location for a perpendicular anode bank.
 - 7.8.2 If the anode bank must be parallel to the protected system, maintain 10ft. separation between the main and foreign structures. See [Appendix A-2](#) - Parallel Anode Bank.
- 7.9 Bury the anodes at least 6 inches below the protected main.
- 7.10 Attach the collector wire to main, and coat connections. See [CORR 2.8 Appendix B](#) - Test Lead Wire Attachment.
- 7.11 Show all anode banks in Ameren's electronic mapping system. Refer to 49 CFR §192.491.
- 7.12 Install stations on those banks which supply sufficient data for the maintenance of the cathodic protection system. The anode test station should: (refer to 49 CFR §192.469)
 - 7.12.1 Provide a test lead to the main.
 - 7.12.2 Allow evaluation of the anodes by measuring the current output.
 - 7.12.3 Provide check for shorts (current high, potential down, etc.).
 - 7.12.4 Provide connection for short location, current requirement, continuity, and insulation tests. (Open bond and use anode cable for ground.)
- 7.13 An above ground test station is preferred. Anchor the station to a permanent structure, if possible, such as a utility pole, post, or building.

End of Instructions.

Operator Qualification (OQ) Required?

YES

0001: Measure Structure- to-Electrolyte Potential

0011: Conduct Close Interval Survey

0021: Measure Soil Resistivity

0031: Inspect and monitor Galvanic Ground Beds/Anodes

0041: Installation and Maintenance of Mechanical Electrical Connections

0051: Installation of Exothermic Electrical Connections

UNCONTROLLED IF PRINTED

0091: Troubleshoot In- Service Cathodic Protection System

Appendices

[Appendix A - Anode Installations](#)

[Appendix B - Anode Test Station](#)

Attachments

NONE.

Compliance Requirements

49 CFR §192.469 External corrosion control: Test stations.

49 CFR §192.491 Corrosion control records.

Reference Documents

[CORR 2.8 Corrosion Control: Cathodic Protection Testing](#)

Document Rescission

CORR 2.2 Corrosion Control: Anode Requirements and Installation, October 1, 2020.

Revision Notes

Location of Changes	Summary of Changes
Section 6.0 Anode Requirements - Table 3	Changed threshold for installing anode on New Steel Service Lines and Repaired Steel Mains and Service Lines to -1.00 v

Appendix A - Anode Installations

A-1. Direct Connection

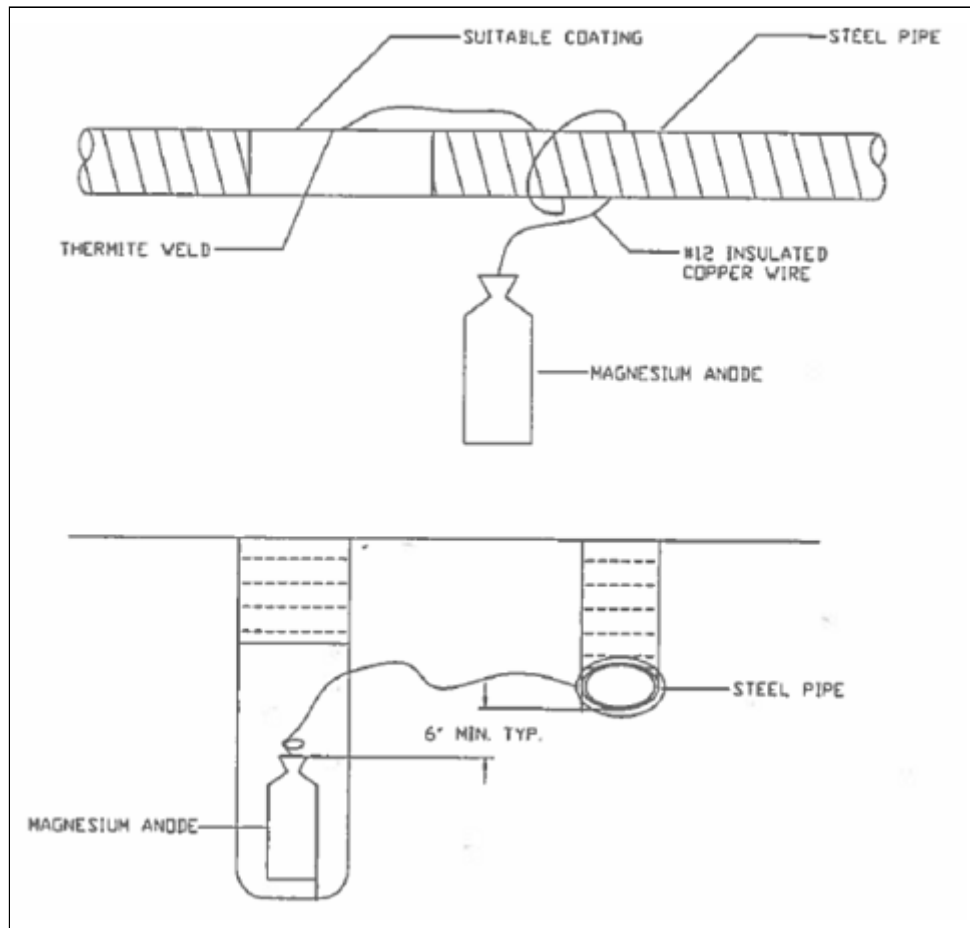

Installation:

1. This standard can be used for single anode installations for new facilities during initial construction or existing facilities when single anodes are needed and test facilities are not desired or required.
2. Install anode in convenient location, as near as practical to that shown on construction drawing and record installation. Installation dimensions are recommended.
3. Anode can be placed vertically or horizontally and a minimum of 6 inches below the bottom of the steel pipe. Anodes may be installed in multiple groupings. No more than 2 anodes shall be installed in an excavation unless 10 feet of spacing can be maintained between the anodes. If multiple connections are made on the pipe, the connections should be at least 6 inches apart.
4. Anode should be placed as far away from the pipe as the excavation safely allows up to the length of the anode lead wire.
5. Carefully lower anode to bottom of hole and center it. Do not lower anode using lead wire.
6. If the Pipe to Soil reading does not change after installation of anode(s), add water to activate.
7. Backfill with fine earth (not sandy or rocky soil) around anode to about 4" above top of bag. Complete backfill with tamped earth.
8. Leave sufficient slack in wire to avoid damage when back-filling.
9. Attach wire in accordance with [CORR 2.8 Appendix B](#) Test Lead Wire Connection.
10. Coat each connection according to the methods described in [CORR 2.8 Appendix B](#).

UNCONTROLLED IF PRINTED

Item	Stock No.	Description	Quantity	
			01	02
1	62 05 082	Anode, Magnesium, 5 #, Packaged, With #12 TW Wire	1*	
	62 05 058	Anode, Magnesium, 17 #, Packaged, With #12 TW Wire		1*
2	22 02 552	Thermite Cad Weld	1	1

* Anodes may be installed in multiple groupings. No more than 2 anodes shall be installed in an excavation unless 10 feet of spacing can be maintained between the anodes.

A-2. Parallel Anode Bank

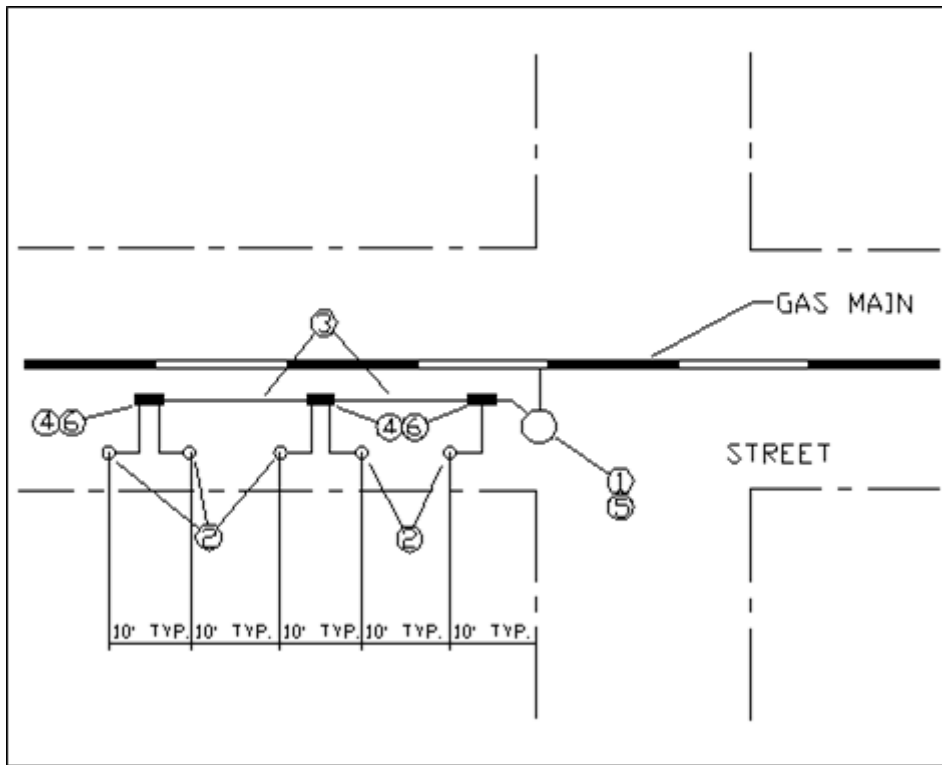

Note: Perpendicular installations are preferred.

Installation

1. Anodes can be installed in banks when adding anodes to existing mains or when a single point of current control is desired for new main installations.
2. Install anodes in convenient location, as near as practical to that shown on construction drawing, and record installation.
3. Anodes can be placed vertically or horizontally and a minimum of 6 inches below the bottom of the steel pipe.
4. Carefully lower or place anode in the hole or excavation and center it. Do not lower anode using lead wire.
5. Connect anode lead wire to collector cable with #8 split bolt (17 54 002).
6. Insulate connections with a splice box (49 62 001) or 4 inch vinyl tape (25 53 225).
7. If the Pipe to Soil reading does not change after installation of anode(s), add water to activate. See [Section 4.7.1](#) in the body of this document.
8. Backfill with fine earth (not sandy or rocky soil) around anode to about 4 inches above top of bag. Complete backfill with tamped earth.
9. Leave sufficient slack in wire to avoid damage when back-filling.

10. Attach wire in accordance with [CORR 2.8 Appendix B](#).
11. Coat connection according to the methods described in [CORR 2.8 Appendix B](#).
12. Terminate wires as shown on construction drawing or neatly in test station box.

Item	Stock No.	Description	Quantity	
			01	02
1	19 12 703	Box, CP Test 4 in ID x 18 in Lgh, Plastic w/Cast Iron Lockable Lid, 5 terminals, Marked "GAS TEST"	1	
	16 02 629	Marker With Big Fink		1
2	62 05 058	Anode Magnesium, 17#	5	5
3	18 66 624	# 8 stranded wire	X	X
4	25 53 225 49 62 001	4" vinyl tape or Splice box	X	X
5	17 54 948	Connector, #14-#4 Wire	2	2
6	17 54 002	Connector, Split Bolt, #8	5	5

X - Number of feet required for specific installation.

A-3. Perpendicular Anode Bank

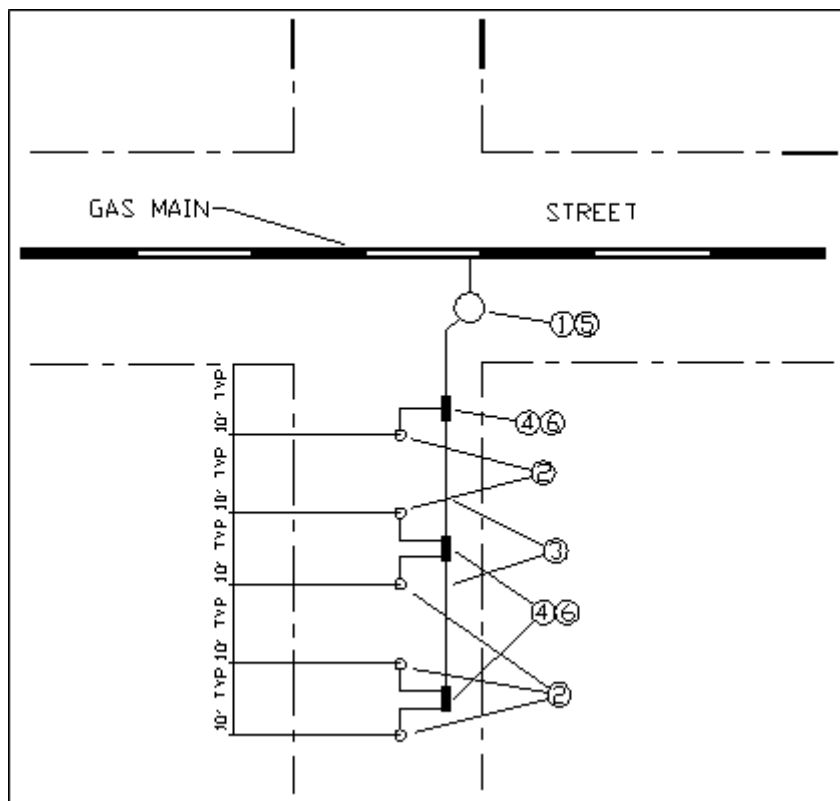

Installation

1. Anodes can be installed in banks when adding anodes to existing mains or when a single point of current control is desired for new main installations.
2. Install anode in convenient location, as near as practical to that shown on construction drawing, and record installation.
3. Anodes can be placed vertically or horizontally and a minimum of six (6) inches below the bottom of the steel pipe.
4. Carefully lower or place anode in the hole or excavation and center it. Do not lower anode using lead wire.

UNCONTROLLED IF PRINTED

5. Connect anode lead wire to collector cable with #8 split bolt (17 54 002).
6. Insulate connections with a splice box (49 62 001) or 4 inch vinyl tape (25 53 225).
7. If Pipe to Soil readings do not change after installation of anode(s), add water to activate. See [Section 4.7.1](#).
8. Backfill with fine earth (not sandy or rocky soil) around anode to about 4 inches above top of bag. Complete backfill with tamped earth.
9. Leave sufficient slack in wire to avoid damage when back-filling.
10. Attach wire in accordance with [CORR 2.8 Appendix B](#).
11. Coat connection according to the methods described in [CORR 2.8 Appendix B](#).
12. Terminate wires as shown on construction drawing or neatly in test station box.

Item	Stock No.	Description	Quantity	
			01	02
1	19 12 703	Box, CP Test 4 in ID x 18 in Lgh, Plastic w/Cast Iron Lockable Lid, 5 terminals, Marked "GAS TEST"	1	
	16 02 629	Marker With Big Fink		1
2	62 05 058	Anode Magnesium, 17#	5	5
3	18 66 624	# 8 Stranded Wire	X	X
4	25 53 225 49 62 001	4" Vinyl Tape or Splice box	X	X
5	17 54 948	Connector, #14-#4 Wire	2	2
6	17 54 002	Connector, Split Bolt, #8	5	5

X - Number of feet required for specific installation.

A-4. Drive-in Anode

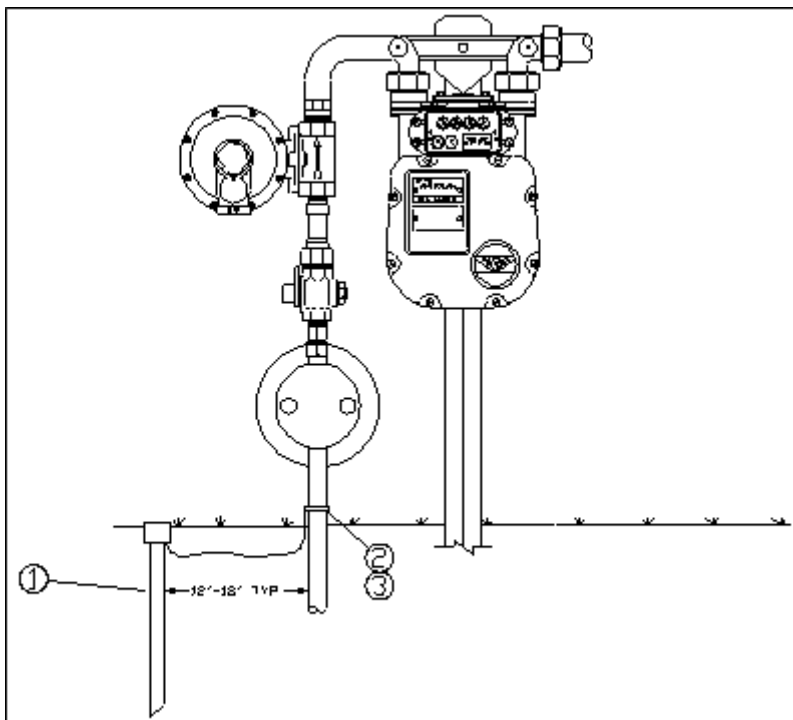

Installation

1. Use only on isolated gas carrying risers on PE services.

2. Clean ¼ inch diameter area to bare metal on riser where point on clamp will make contact.
3. Apply thin film of wax tape primer over area where clamp will make contact.
4. Install clamp on riser to ensure that the point makes direct contact with the riser on clean area.
5. A grounding clamp can be used in place of the clamp that comes with the drive-in anode. The riser will have to be cleaned down to bare metal where the grounding clamp makes contact.
 - Grounding clamp for 1/2 and 1 inch risers is Stock Code 40 59 319
 - Grounding clamp for 1-1/4 and 2 inch risers is Stock Code 40 59 318
6. Coat riser and clamp with wax tape primer from ground line to bottom of meter stop valve.
7. Apply wax tape to primed areas. Leave tape loose over clamp initially, and wrap riser tightly above clamp. Apply tape up to bottom of meter stop. Rub and press tape until it is firmly in place and all seams are smooth. Wax tape should be applied over the anode wire from the ground to the clamp.
8. The preferred method of handling the excess anode wire is to wrap the excess wire around the anode. However, if conditions do not allow for that, the excess wire can be wrapped around the riser
9. Typically place anode approximately 12 to 18 inches from the riser and drive with hammer until head is below grade.
10. If the Pipe to Soil reading does not change after installation of anode, add water to activate. See [Section 4.7.1](#).

Item	Stock No.	Description	Quantity
1	62 05 069	1 1/2# Drive in Anode	1
2	30 58 149	Wax Tape Primer	X
3	25 53 206	Wax Tape	X

X - Number of feet required for specific installation.

A-5. Isolated Steel Service Line

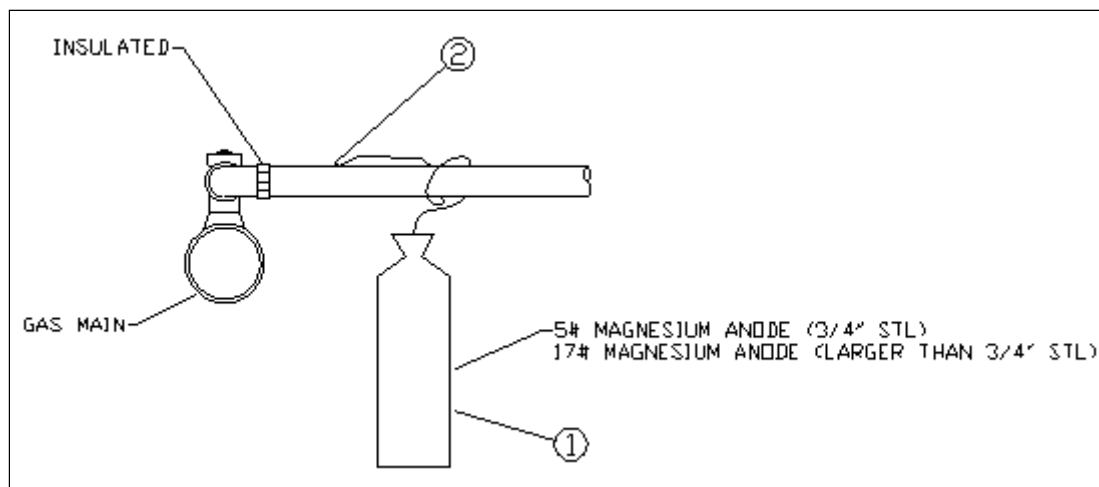

Installation

1. This installation should only be used on isolated steel service lines.
2. The anode may be installed in the main bell hole or at the building wall for most individual services.

UNCONTROLLED IF PRINTED

3. Typically keep anode a minimum of 24 inches from main toward meter.
4. Typically install top of anode a minimum of 6" below service. The anode can be placed vertically or horizontally.
5. Attach wire in accordance with [CORR 2.8 Appendix B](#).
6. Coat each connection according to the methods described in [CORR 2.8 Appendix B](#).
7. If the Pipe to Soil reading does not change after installation of anode(s), add water to activate. See [Section 4.7.1](#).

Item	Stock No.	Description	Quantity	
			01	02
1	62 05 082	5# Magnesium Anode	1	
	62 05 058	17# Magnesium Anode		1
2	22 02 552	Thermite Cad Weld	1	1

Appendix B - Anode Test Station

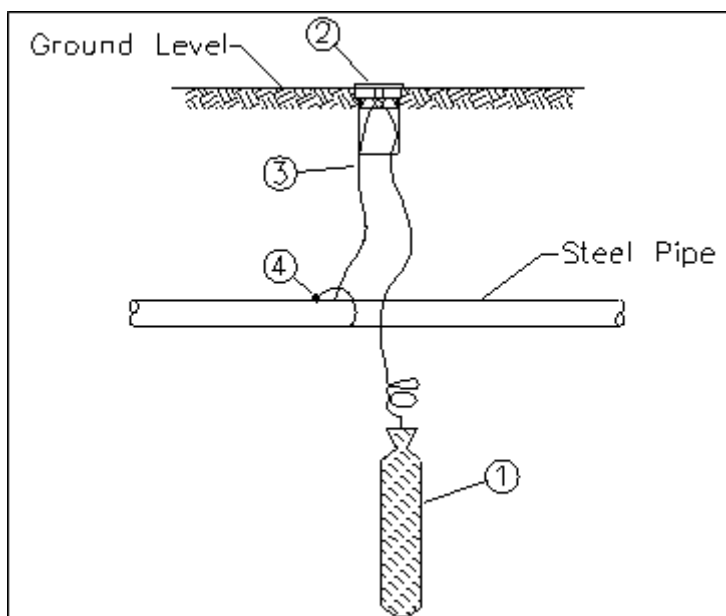

Installation

1. This standard can also be used when an access point to the pipe is desired for a purpose such as locating.
2. Install anode in convenient location, as near as practical to that shown on construction drawing, and record installation.
3. Anode can be placed vertically or horizontally and a minimum of 6 inches below the bottom of the steel pipe. Anodes may be installed in multiple groupings. No more than 2 anodes shall be installed in an excavation unless 10 feet of spacing can be maintained between the anodes. If multiple connections are made on the pipe, the connections should be at least 6 inches apart.
4. Anode should be placed as far away from the pipe as the excavation safely allows up to the length of the anode lead wire.
5. Carefully lower anode to bottom of hole and center it. Do not lower anode using lead wire.

6. If the Pipe to Soil reading does not change after installation of anode(s), add water to activate. See [Section 4.7.1](#).
7. Backfill with fine earth (not sandy or rocky soil) around anode to about 4 inches above top of bag. Complete backfill with tamped earth.
8. Leave sufficient slack in wire to avoid damage when back-filling.
9. Attach wire, in accordance with [CORR 2.8 Appendix B](#).
10. Coat each connection according to the methods described in [CORR 2.8 Appendix B](#).
11. Terminate wires as shown on construction drawing or neatly in test station box.
12. Record measurements and provide a sketch or place the information on a copy of Ameren Map Viewer map and submit to a Poster for recording in the electronic mapping system.

Item	Stock No.	Description	Quantity	
			01	02
1	62 05 082	Anode, Magnesium, 5 #, Packaged, With #12 TW Wire	1	
	62 05 058	Anode, Magnesium, 17 #, Packaged, With #12 TW Wire		1
2	19 12 703	Box, CP Test 4 in ID x 18 in Lgh, Plastic w/Cast Iron Lockable Lid, 5 terminals, Marked "GAS TEST"	1	1
3	18 66 208	Wire, Detector, #12 AWG,TW CU, Insulated - 500 feet spool	X	X
	18 66 369	Wire, Detector, #12 AWG,TW CU, Insulated - 1500 feet spool		
4	22 02 552	Thermite Cad Weld	1	1

X - Number of feet required for specific installation.

Notes:

1. Use 5# Anode on Isolated 3/4 inch steel service lines
2. Use 17# Anode on Isolated 1 inch and larger steel service lines
3. Use 17# Anode on steel mains

CORROSION CONTROL

April 1, 2023

CORR 2.3 Coatings

1.0 Purpose

This document provides for the requirements of pipeline facility coating selection, installation, repair, and inspection meeting the minimum requirements of 49 CFR §§ 192.112, 192.307, 192.328, 192.455, 192.461.

2.0 Scope

This document addresses the following:

[3.0 Target Audience](#)

[4.0 Approved Coatings](#)

[5.0 Approved Hot Applied Tapes](#)

[6.0 Approved Cold Applied Tapes](#)

[7.0 Approved Field Applied Epoxy Coatings](#)

[8.0 Approved Cold Applied Wax Tapes](#)

[9.0 Moisture Cured Wrap](#)

[10.0 Approved Paint Specification](#)

[11.0 Coating Inspection](#)

[12.0 Approved Epoxy Coating for Submerged Facilities](#)

Appendices:

[Appendix A - Approved Coating Types for Installations](#)

[Appendix B - Coating Repair](#)

[Appendix C - Approved Hot Applied Tapes](#)

[Appendix D - Approved Cold Applied Tapes](#)

[Appendix E - Approved Field Applied Epoxy Coatings](#)

[Appendix F - Applied Cold Wax Tapes](#)

[Appendix G - Moisture Cured Wraps \(MCW\)](#)

[Appendix H - General Wrapping Instructions](#)

[Appendix I - Specific Coatings](#)

[Appendix J - Approved Paints for Pipeline Facility Coating](#)

[Appendix K - Coating Inspection](#)

[Appendix L - Protal Applications](#)

[Appendix M Epoxy Coating for Submerged Facilities](#)

3.0 Target Audience

- Gas Engineering
- Gas Construction Services Supervisors

UNCONTROLLED IF PRINTED

- Gas Tech Engineering (GTE)
- Corrosion Control Supervisors
- Corrosion Control Specialists
- Pipeline Integrity Management Personnel
- Gas Field Personnel
- Gas Supervisors
- Gas Construction Contractor Supervisors
- Gas Construction Services Inspectors
- Gas Storage Engineering
- Gas Storage Field Supervisors
- Gas Storage Field Operators

4.0 Approved Coatings

- 4.1 New Pipe Installation: The tables listed in [Appendix A](#) lists the approved coatings for girth welds on various steel pipe sizes and installation processes.

These coating requirements are for distribution, high pressure distribution and transmission pipe.

4.1.1 Direct Bury Installation

1. Ameren Illinois' (AIC) standard mill coated pipe shall be coated with fusion bond epoxy (FBE), approximately 16 mils thick (minimum 12 mil/ maximum 28 mil), in accordance with the current coating specification.
2. Girth weld joints shall be coated in accordance with [Appendix A-1](#).
3. Installation Instructions:
 - 3 a. Field Applied Liquid Epoxy. See [Appendix L](#) - Protal Applications.
 - 3 b. Hot applied tape:
 - (i) Tapecoat 20 - See [Appendix I-1](#).
 - (ii) Densotherm - See [Appendix I-2](#).
 - 3 c. Cold applied tape:
 - (i) Tapecoat H35 - See [Appendix I-3](#).
 - (ii) Denso Butyl 35 - See [Appendix I-4](#)

4.1.2 Directional Drilling Installation

1. All steel pipe 2 inches and larger in diameter to be installed by directional drilling shall be dual coated with:
 - 1 a. An initial layer of FBE, approximately 16 mils thick (minimum 12 mil/ maximum 28 mil).And
 - 1 b. A second layer of an abrasive resistant overcoating (ARO), minimum 20 mils thick. (Industry standard for ARO is 30 mil)
2. Steel pipe smaller than 2 inches does not require an ARO over the FBE since the bore hole diameter is significantly larger than the pipe being installed.
3. Girth weld joints shall be coated in accordance [Appendix A-2](#).
4. Installation instructions:

- 4 a. See [Section 4.1.1 \(3\)](#) for Field Applied Liquid Epoxy, Hot Applied Tape, and Cold Applied Tape.
- 4 b. Moisture Cured Wrap (MCW)
 - (i) Trenton MC110 Outerwrap or Denso Glass Outerwrap - See [Appendix I-5](#).

4.2 Joint Coating

- 4.2.1 Girth weld joint coating shall comply with Appendix [A-1](#) or [A-2](#), whichever is applicable. Coasting on other joints on steel pipe shall normally be made with hot applied tape or liquid epoxy coating.
- 4.2.2 Where the joint is near plastic pipe, the wrapping shall be made with cold applied tape or liquid epoxy coatings.

4.3 Coating Repair

- 4.3.1 For pipe coating repair see [Appendix B-1](#).
- 4.3.2 For fitting coating repair see [Appendix B-2](#).

4.4 Service Line Tees

- 4.4.1 Service tees connecting steel services to steel mains shall be coated with a hot applied tape or wax tape.
- 4.4.2 Service tees connecting plastic services to steel mains should be coated with a wax tape.

4.5 Fittings

- 4.5.1 All below ground fittings such as valves, line stopper fittings, bolted couplings, weld end fittings, etc., shall be coated with one of the following:
 - 1. Fusion bonded epoxy (FBE)
 - 2. Field applied epoxy coating
 - 3. Wax tape
 - 4. Cold applied tape
 - 5. Hot applied tape
 - 6. Coal tar epoxy (Bitumastic)
- 4.5.2 Coating on below grade valves provided by the valve manufacturer, valve supplier, or fabricating shop can be used in-lieu of AIC approved coating if approved by the Superintendent of Corrosion Control.
- 4.5.3 Below ground leak clamps shall be coated with wax tape.
- 4.5.4 Irregular shaped fittings and those with bolts should be coated with wax tape in accordance with [Section 8.0](#). These fittings may require the application of profiling material prior to coating with the wax tape.

4.6 Soil to Air Interface Zone

- 4.6.1 Disbonded coating shall be repaired using wax tapes or cold applied tapes in the soil to air interface zone.
 - 1. Refer to [CORR 1 Section 15.5](#) for repair procedures.

2. The wax or cold applied wrap shall terminate with a good tight seal near the bottom of the meter valve
- 4.6.2 For anodeless risers do not wrap the PE to steel transition area. The pipe above the transition should be painted
- 4.6.3 Non-wax based cold applied tapes or moisture cured wrap shall be used on gas carrying risers for new construction where significant settling of adjacent soil is expected.
- 4.6.4 All approved underground coatings that extend above grade on newly installed risers shall be over coated with a UV resistant coating, such as:
 1. Cold applied tape
 2. Cold applied wax tape
 3. Moisture cured wrap
- 4.6.5 The UV resistant coating should extend from approximately 12 inches below grade to above final grade.
- 4.6.6 The UV resistant coating should be applied using a continuous application method.

Paint is not an approved UV resistant coating.

Moisture cured wrap can be applied as a protective overcoat over all of the other approved coating materials when there is a need to provide additional protection from abrasive action or mechanical damage to the pipe coating. **MCW should extend a minimum of 2 inches passed the other coating material per Trenton MCO 110 Outerwrap Application Procedures. See CORR 3.**

4.7 Above Ground Facilities

- 4.7.1 All above ground facilities shall be coated with an approved coating (i.e. cold applied tape, cold applied wax tape, or paints).
- 4.7.2 The surface must be clean, dry, and in sound condition.
- 4.7.3 All oil, dust, grease, dirt, loose rust, and other foreign material shall be removed to ensure adequate adhesion.

5.0 Approved Hot Applied Tapes

- 5.1 The stock codes listed in [Appendix C](#) for hot applied tapes are approved for below ground use only.

6.0 Approved Cold Applied Tapes

- 6.1 No wrinkles in the cold applied tape shall be left. All wrinkles must be cut out and re-taped.
- 6.2 The stock codes listed in [Appendix D](#) for cold applied tapes are approved for above and below ground use.

7.0 Approved Field Applied Epoxy Coatings

- 7.1 The stock codes for field applied epoxy coatings listed in [Appendix E](#) are approved for above and below ground use.
- 7.2 Repair cartridges are for repairing coating damages.

8.0 Approved Cold Applied Wax Tapes

- 8.1 Wax tape is a coating used for coating irregular shaped fittings which cannot be wrapped with the more durable hot or cold-applied tape.
- 8.2 Irregular fittings should have the irregular surfaces coated with profiling material to create a smooth surface prior to applying the wax tape.
- 8.3 Care should be taken during backfill operations to prevent damage to the wax coating. A mesh outer wrap can be used to protect the wax tape during backfilling.
- 8.4 The stock codes listed in [Appendix F](#) for waxed tapes are approved for above and below ground use.

9.0 Moisture Cured Wrap

- 9.1 See [Appendix G](#) for approved moisture cured wrap.

10.0 Approved Paint Specification

10.1 Approved Paints

- 10.1.1 Gas meter sets shall be coated with a brush applied gray paint. See [Appendix J](#).
- 10.1.2 First cut farm taps and small regulator stations shall be coated with brush applied paint. See [Appendix J](#).

Shop fabricated farm taps and small regulator stations can be coated with any of the approved paints listed in [Appendix J](#). Application shall be in accordance with manufacturer's specifications and instructions. Refer to [CORR 3](#).

- 10.1.3 The following facilities shall be coated with one of the approved paints or two part paints listed in [Appendix J](#) and in accordance with manufacturer's instructions:
 - 1. Pipeline delivery station.
 - 2. Transmission regulator station.
 - 3. Town border station.
 - 4. Large distribution regulator station.
 - 5. Gas storage field piping
- 10.1.4 Regulator stations that are annually inspected can be touched up with an aerosol spray paint until a total repaint is necessary. See [Appendix J](#).

Use care to protect other facilities from over spray.

10.1.5 Surface Preparation

1. Surface must be clean, dry, and in sound condition.
2. Remove all oil, dust, grease, dirt, loose rust, and other foreign material to ensure adequate adhesion.

10.1.6 Temperature limitations

1. Application temperature limits are listed on the Manufacturer's paint specification sheets.
2. The temperature limits are for the temperature of the pipe not necessarily the ambient temperature. See [CORR 3](#) Forms and Reference Materials.

11.0 Coating Inspection (49 CFR §192.461 (c))

11.1 Coated steel pipe shall be tested for holidays and overall coating integrity prior to installation.

11.2 Inspection Requirements

11.2.1 All pipe coating shall be visually inspected at the time of delivery. Prior to installation, all pipe coating shall be inspected in accordance with [Appendix K-1](#) and [Appendix K-2](#).

1. Inspection Methods. See [Appendix K-1](#).
2. Inspection Voltage. See [Appendix K-2](#).
 - 2 a. Inspect coating using an approved holiday detector with appropriate voltage range. If the voltage output of a holiday detector does not match the indicated voltage in the chart below, use the next lower setting.
 - 2 b. Inspect coating on pipe that does not require the use of holiday detector, per [Appendix K-1](#), by sliding hands along the pipe feeling rough spots then visually inspect those locations.
 - 2 c. Average total mil thickness 12 mil thru 28 mil would be FBE coating only.
 - 2 d. Average total mil thickness 32 mil thru 58 mil would be for FBE with ARO
 - 2 e. If the average total thickness is not shown on the chart, contact Superintendent Corrosion Control for the proper test voltages. See [Appendix K-2](#).

11.3 Equipment

- 11.3.1 Holiday detectors should be field tested or tested by the manufacturer to insure proper operation.
- 11.3.2 Field testing may be either testing the unit on a known holiday or testing with the proper volt meter for the unit.
- 11.3.3 Perform all required equipment checks and calibrations in accordance with manufacturer's recommendations.

UNCONTROLLED IF PRINTED

11.3.4 Equipment Check

1. Test battery for proper voltage output.
2. Inspect the roller spring for damage or deformation.
3. Connect exploring electrode and grounding cable to terminal of detector.
4. Switch detector to "on" position.
5. Touch exploring electrode to ground cable alligator clip. Instrument signal should be heard.
6. If instrument signal is heard, instrument is ready for use. If signal fails, consider instrument defective.

11.3.5 Inspection Procedure

1. Pipe to be inspected shall be grounded from bare end of pipe to the earth.

When joints of pipe are being tested, individually ground each joint.

2. If moisture exists on coating surface, dry the surface before conducting test.

Moisture on the coating surface can cause incorrect indications.

3. Make contact with the detector electrode on bare pipe end to verify that the instrument is properly grounded.
 - 3 a. Repeat this procedure each time a different section of coated pipe is tested.
 - 3 b. If the unit is not grounded, reground the equipment by cleaning the pipe wall at the ground connection and retest.
4. For applications requiring a spring-type electrode, use a single pass, moving electrode over surface at a rate of approximately 1 foot per second.
5. For applications requiring a brush-type or half-circle electrode, a pass on each side of the pipe, 180° apart is required.
6. As defects are identified, mark the locations so repairs can be made prior to installation.

11.3.6 Coating Repairs

1. Clean the area of dirt, scale, and damaged coating.
2. See [Section 4.1.1 \(3\)](#) for coating repair requirements for both line pipe and fittings.

11.3.7 Re-inspection

Solvents retained in the coating film can produce incorrect results, as well as a hazardous environment.

1. Allow the repaired coating areas sufficient time to cool, dry, and cure prior to retesting.
2. Retest the repaired areas in accordance with approved testing procedures.

11.3.8 Calibration

1. Return holiday detectors to the manufacturer for calibration on an annual basis unless a high voltage meter for the particular detector indicates it is functioning properly.

12.0 Approved Applied Epoxy Coatings for Submerged Facilities

12.1 These epoxy coating are only approved for use on facilities that are either routinely subjected to being submerged or permanently submerged in water.

12.2 SeaShield 525 Epoxy is designed to be:

12.2.1 Applied primarily to facilities that are routinely subjected to being submerged in water.

12.2.2 Applied to dry, damp or wet steel, concrete or wood to provide corrosion protection and sealing.

12.2.3 Applied with brush, gloved hand, applicator pad or roller.

12.3 SeaShield 526 Epoxy is designed to be:

12.3.1 Applied primarily to facilities that are underwater but can also be applied to above ground facilities susceptible to being submerged.

12.3.2 Applied to dry, damp or wet steel, concrete or wood structures for corrosion protection or sealing.

12.3.3 Applied with trowel, putty knife, gloved hand or applicator pad.

12.4 SeaShield 525 Epoxy and SeaShield 526 Epoxy shall be applied in accordance with Denso's instructions. See [CORR 3](#) for manufacturer's instructions.

12.5 The stock codes for these specialized epoxy coatings are listed in [Appendix M](#).

End of Instructions.

Operator Qualification (OQ) Required?

YES.

0141: Visual Inspection for Atmospheric Corrosion

0151: Visual Inspection of Buried Pipe and Components when Exposed

0201: Visual Inspection of Installed Pipe and Components for Mechanical Damage

0991: Coating Application and Repair - Brushed or Rolled

UNCONTROLLED IF PRINTED

1001: Coating Application and Repair - Sprayed

1011: External Coating Application and Repair - Wrapped

Appendices

[Appendix A - Approved Coating Types for Installations](#)

[Appendix B - Coating Repair](#)

[Appendix C - Approved Hot Applied Tapes](#)

[Appendix D - Approved Cold Applied Tapes](#)

[Appendix E - Approved Field Applied Epoxy Coatings](#)

[Appendix F - Applied Cold Wax Tapes](#)

[Appendix G - Moisture Cured Wrap](#)

[Appendix H - General Wrapping Instructions](#)

[Appendix I - Specific Coatings](#)

[Appendix J - Approved Paints for Pipeline Facility Coating](#)

[Appendix K - Coating Inspection](#)

[Appendix L - Protal Applications](#)

[Appendix M – Epoxy Coating for Submerged Facilities](#)

Attachments

NONE.

Compliance Requirements

49 CFR §192.112 Additional design requirements for steel pipe using alternative maximum allowable operating pressure.

49 CFR §192.307 Inspection of materials.

49 CFR §192.328 Additional design requirements for steel pipe using alternative maximum allowable operating pressure.

49 CFR §192.455 External corrosion control: Buried or submerged pipelines installed after July 31, 1971.

49 CFR §192.461 External corrosion control: Protective coating.

Reference Documents

[CORR 1 Corrosion Control: Requirements](#)

[CORR 3 Corrosion Control: Forms and Reference Materials](#)

Document Rescission

CORR 2.3 Corrosion Control: Coatings, October 1, 2022

Revision Notes

Location of Changes	Summary of Changes
---------------------	--------------------

Paragraph 4.1.2 – Item 4 b. (i) – Moisture Cured Wrap	Updated Trenton MC110 Outerwrap
Paragraph 4.5.2 – Precoat-ed below grade valves	New – Coating on below grade valves provided by the valve manufacturer, valve supplier, or fabricating shop can be used in-lieu of AIC approved coating if approved by Superintendent of Corrosion Control.
Paragraph 4.6.6 NOTE	Added – MCW shall extend a minimum of 2 inches passed the other coating material per Trenton MC110 Outerwrap Application Instructions. See CORR 3.
Subsection 6.1 – Cold Ap-plied Tape	Revised – No wrinkles in the cold applied tape shall be left. All wrinkles must be cut out and retaped Removed exposed to soil language.
Appendix B-1 & B-2 – Coat-ing Repair	Grammatical – "inches" replaced inch
Appendix G Moisture Cured Wrap	Updated Trenton MC110 Outerwrap
Appendix H - 3.A.through 3. C. – General Wrapping Instructions	Grammatical – "inches" replaced inch
Appendix H – 4. A.	Grammatical – Added "cold applied" to wax tape. Clari-fy cold applied tape and cold applied wax tape are two separate products.
Appendix I-1, 2. C. – Tapecoat 20	Grammatical – "inches" replaced inch
Appendix I-3 Tapecoat H35 – 1. B.	Revised – No wrinkles in the cold applied tape shall be left. All wrinkles must be cut out and retaped Removed exposed to soil language.
Appendix I-3 Tapecoat H35 – 3. A.	Grammatical – "inches" replaced inch
Appendix I-4 Denso Butyl 35 – 1. B.	Revised – No wrinkles in the cold applied tape shall be left. All wrinkles must be cut out and retaped Removed exposed to soil language.
Appendix I-5 Moisture Cured Wrap – 1. C. & 2. A.	Grammatical – "inches" replaced inch
Appendix I-5 Moisture Cured Wrap – 2. Application Procedures for Girth Weld	Grammatical – Rearranged some of the steps and split some of original steps into individual line items.
Appendix I-5 Moisture Cured Wrap – 3. Comple-tion and Curing of MCW Wrap	Grammatical – A. (1) – Capitalized "OR" C. – Moved 1 st sentence into a NOTE

Appendix I-5 Moisture Cured Wrap – 4. Application Procedures at Soil Air Interface Zone	4. B. – Reformatted, split into individual steps. H.- separated from G. L - separated from K M – removed "as stated above"
Appendix I-5 Moisture Cured Wrap – 5. Moisture Cured Wrap Coverage Table	Note below Table – "inches" replaced "inch"
Appendix I-6 Tapecoat TC Color Coat – 3. A. Table, Note	Grammatical – "inches" replaced inch
Appendix I-7 Trenton #2 Wax Tape – 3. A.	Grammatical – "inches" replaced inch
Appendix I-7 Trenton #2 Wax Tape – 3. B.	Grammatical – "lbs." replaced lb.
Appendix J - Approved Paint	Added – Tnemec Series 1095

Appendix A - Approved Coating Types for Installations

A-1. Direct Bury Installations

	Girth Weld Coating
Pipe Size (inches)	Initial Coating
12" and Larger	Field Applied Liquid Epoxy
2" to Less than 12"	Field Applied Liquid Epoxy Or Hot Applied Tape
Less than 2"	Field Applied Liquid Epoxy Or Hot Applied Tape Or Cold Applied Tape (1)
(1) Wax tape is not an acceptable coating	

A-2. Directional Drilling Installation

	Girth Weld Coating	
Pipe Size (inches)	Initial Coating	Sacrificial Overcoating
6" and Larger	Field Applied Liquid Epoxy	Moisture Cured Wrap
2" to Less than 6"	Field Applied Liquid Epoxy Or Hot Applied Tape	Moisture Cured Wrap
Less than 2"	Field Applied Liquid Epoxy Or Hot Applied Tape Or Cold Applied Tape (1)	Not Required
(1) Wax tape is not an acceptable coating		

Appendix B - Coating Repair

B-1. Pipe Coating Repair

Line Pipe coating	Repair coating	Diame-ter	Repair Requirements
Coal tar	Hot applied tape	< 6"	Full encirclement
Coal tar	Hot applied tape	>= 6"	Extend at least 6 inches beyond the edge of a defect no larger than 1/4 of the pipe circumference
Coal tar	2 part Liquid Epoxy	All	Extend at least minimum of 1 inch beyond the edge of the defect or full encirclement
Coal tar	Cold applied Butyl 35 or H35	All	Full encirclement
XTRU	Hot applied tape	< 6"	Full encirclement
XTRU	Hot applied tape	>= 6"	Extend at least 6 inches beyond the edge of a defect no larger than 1/4 of the pipe circumference
XTRU	Cold applied Butyl 35 or H35	All	Full encirclement

FBE	Hot applied tape	< 6"	Full encirclement
FBE	Hot applied tape	>= 6"	Extend at least 6 inches beyond the edge of a defect no larger than 1/4 of the pipe circumference
FBE	2 part Liquid Epoxy	All	Extend at least minimum of 1 inch beyond the edge of a defect no larger than 1/4 of the pipe circumference or full encirclement
FBE	Cold applied Butyl 35 or H35	All	Full encirclement
Wax tape is not acceptable for coating repair.			

B-2. Fitting Coating Repair

Fitting coating	Repair coating	Diameter	Repair requirements
FBE	Hot applied tape	< 6"	Full encirclement
FBE	Hot applied tape	>= 6"	Extend at least 6 inches beyond the edge of a defect no larger than 1/4 of the pipe circumference
FBE	2 part Liquid Epoxy	All	Extend at least minimum of 1 inch beyond the edge of a defect no larger than 1/4 of the pipe circumference or full encirclement
FBE	Any Cold Applied Tape	All	Full encirclement
Hot Applied Taps	Hot Applied Tape	< 6"	Full encirclement
Hot Applied Taps	Hot Applied Tape	>= 6"	Extend at least 6 inches beyond the edge of the defect or full encirclement
Liquid Epoxy	2 part Liquid Epoxy	All	Extend at least minimum of 1 inch beyond the edge of a defect no larger than 1/4 of the pipe circumference or full encirclement
Liquid Epoxy	Hot Applied Tape	< 6"	Full encirclement
Liquid Epoxy	Hot Applied Tape	>= 6"	Extend at least 6 inches beyond the edge of the defect or full encirclement
Liquid Epoxy	Any Cold Applied Tape	All	Full encirclement

Wax Tape	Wax Tape	All	Full encirclement
Cold Applied Butyl 35 or H35	Any Cold Applied Tape	All	Full encirclement

Appendix C - Approved Hot Applied Tapes

C-1. Tapecoat - Instructions [Appendix I-1](#)

Tapecoat Items	Stock No.
TC Omniprime	49 22 084
Tapecoat 20 - 2"	25 53 068
Tapecoat 20 - 3"	25 53 067
Tapecoat 20 - 4"	25 53 059
Tapecoat 20 - 6"	49 35 194

C-2. Denso - Instructions [Appendix I-2](#)

Denso Item	Stock No.
Denso Primer D	49 17 762
Densotherm - 2"	49 22 386
Densotherm - 4"	25 53 174
Densotherm - 6"	25 53 168

Appendix D - Approved Cold Applied Tapes

D-1. Tapecoat - Instructions [Appendix I-3](#)

Tapecoat Item	Stock No.
TC Omni Primer	49 22 084
Tapecoat H35 - 2"	49 22 095
Tapecoat H35 - 4"	49 22 394
Tapecoat H35 - 6"	49 22 395

D-2. Denso - Instructions [Appendix I-4](#)

Denso Item	Stock No.
Denso Butyl Primer	49 22 393
Denso Butyl 35 tape - 2"	49 22 387
Denso Butyl 35 tape - 4"	49 22 388
Denso Butyl 35 tape - 6"	49 22 389

Appendix E - Approved Field Applied Epoxy Coatings

Item	Size	Stock No.	Hand Gun
Denso Protal 7200			

Hand Applied Protal 7200	1000 ml Kit	49 22 390	
Repair Cartridge	50 ml	49 22 427	49 22 465
Repair Cartridge	400 ml	49 22 457	49 22 456
Static Mixing Tips	50 ml	49 22 463	
Static Mixing Tips	400 ml	49 22 462	
Denso Protal 7125			
Hand Applied Protal 7125	825 ml Kit	49 22 417	
Repair Cartridges	50 ml	49 22 454	49 22 455
Static Mixing Tips	50 ml	49 22 463	
Denso Protal 7200			
Spray Applied Protal 7200 - Cartridge	1000 ml	49 22 466	49 22 461
Straight Tips	1000 ml	49 22 458	
Right Angle Tips	1000 ml	49 22 459	
Quick Lock Adapter			49 22 460
Denso Protal 7300			
Hand Applied Protal 7300	1000 ml Kit	49 22 469	

Appendix F - Applied Cold Wax Tapes

F-1. Tapecoat - Instructions [Appendix I-6](#)

Tapecoat Item	Stock No.
TC Color Coat Primer	49 22 392
TC Color Coat - 2"	49 35 196
TC Color Coat - 4"	49 35 197
TC Color Coat - 6"	25 53 207

F-2. Trenton - Instructions [Appendix I-7](#)

Trenton Item	Stock No.
TemCoat Primer	30 58 149
Trenton #2A tape - 2"	25 53 205
Trenton #2A tape - 4"	25 53 206
Trenton #2A tape - 6"	25 53 204
Trenton Profiling Material	49 22 396
Trenton Fill-Pro PM-GP	49 22 430
Glas-Wrap - 4"	49 22 413
Glas-Wrap - 6"	49 22 412

Notes:

1. Tapecoat TC Color Coat wax tape will be replacing Denso Color Tape. The current supply of Denso wax tape products are approved for continued use until supply is depleted.
2. TC Color Coat Primer and TemCoat Primer are interchangeable and can be used with either the Tapecoat Color Coat or Trenton #2A wax tapes.

Appendix G - Moisture Cured Wrap - Instruction [Appendix I-5](#)

Item	Stock No.
Trenton MC110 Outerwrap 4" x 27'	49 22 435
Denso Glass Outerwrap 4" x 30'	49 22 436
Trenton MC Outerwrap 9" x 40'	49 22 438
Denso Glass Outerwrap 8" x 40'	49 22 439
Polyethylene/Stretch Wrap 5" x 200'	49 22 492

Appendix H - General Wrapping Instructions

1. General

- A. All surfaces to be wrapped must be cleaned and free of oils, dirt, moisture, or other contaminants that would interfere with the adhesion to the pipe.
- B. Allow hot welds to air cool normally until comfortable to the touch before priming in order to avoid burning the primer.
- C. CAUTION, do not use hot applied tape on or near plastic pipe. The heat from either the torch or the hot tape may damage the plastic pipe.
- D. Epoxy coatings require the surface to be cleaned to a near white finish. Small repair areas shall be roughened using sandpaper then wiped clean with isopropyl alcohol. For large areas or many small areas, sandblasting should be considered.
- E. Both hot and cold applied tapes should overlap existing coatings by at least 2 inches at each end of the area wrapped.

2. Hot Tape Application

- A. Clean off pipe and coating charred by heat of welding on both sides of joint and dry pipe surface with torch. Clean area to be coated as necessary. When cool to touch, apply a thin uniform coating of primer to all areas where tape is to be applied. Let primer dry to a tacky consistency before applying tape. Do not use torch to dry primer.

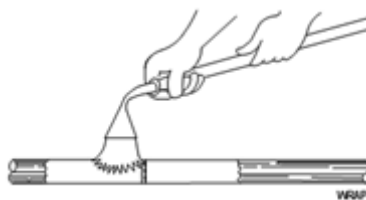

- B. Flash torch flame lightly on top surface of unrolled end of wrap to bleed coating and assure good bond on pipe at start of wrapping.



- C. Start wrapping on mill coating. Spiral wrap with a minimum of 1 inch overlap. Flash edge of overlap as wrap progresses and keep enough heat and tension on tape to force coal tar to ooze out at the overlap. Flash torch flame lightly on top surface of unrolled end of wrap to bleed coating and assure good bond on pipe at start of wrapping.

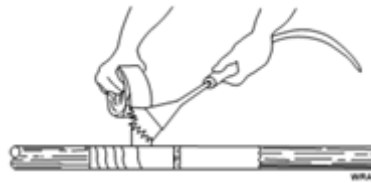

- D. Finish wrapping on mill coating. *Do not flash finished wrap on the Tapecoat 20* because the Mylar surface should remain intact to provide barrier against soil adhesion. *Flash the finished wrap on the Densotherm Tape* to obtain the glossy finish.



Note: For pipe to be pulled into a directional bore hole, wrap joints with spiral towards the leading edge of pull.

3. Service Tee Hot Applied Tape

- A. When a service tee or small fitting is installed on a 6 inches diameter or larger FBE or coal tar coated steel pipe, hot wrap or liquid epoxy shall be used to cover the exposed bare pipe created where the pipe coating was removed so the service tee or small fitting could be welded to the pipe. Small area should be no larger than approximately 1/4 of the pipe diameter. Care must be taken to ensure the hot wrap or liquid epoxy is extended at least 6 inches beyond the bare area and the edges of the hot wrap are sealed tightly to the existing coating such that the edges will not come loose and roll-back as the pipe moves. Existing pipe coating does not have to be completely removed from around the pipe.
- B. When a service tee or fittings is installed on steel pipe smaller than 6 inch diameter, the hot wrap shall be installed in accordance the instructions below.
- (1) Priming Preparation
- Remove coating from the line pipe.
 - Clean surface immediately adjacent to the tee location to bare metal and weld on tee.
 - Brush off weld slag and charred coating remaining.
 - Prime all surfaces to be taped with a thin uniform coating of primer (pre-heat surfaces to remove any moisture).
 - Extend primer a minimum of 2 inches onto the undisturbed mill coating.
 - Let primer dry to a tacky consistency before applying tape.

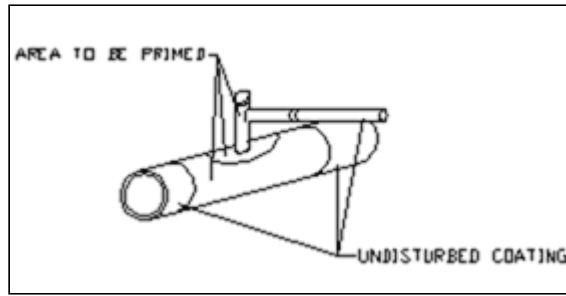

C. Application of Hot Applied Tape

(1) Typical application for all standard coatings. Rip off 5 lengths of 2 inches wrap about 6 inches long and apply wrap to primed surfaces as follows:

(a) Flash tape #1 and pull down into Figure U over base weld. Repeat from opposite side with tape #2. Tapes will crisscross and cover base weld.

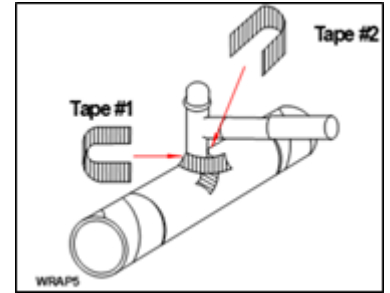

(b) Repeat Step 1 application at tee outlet with tapes #3 and #4. Press tapes firmly against the metal where they crisscross.

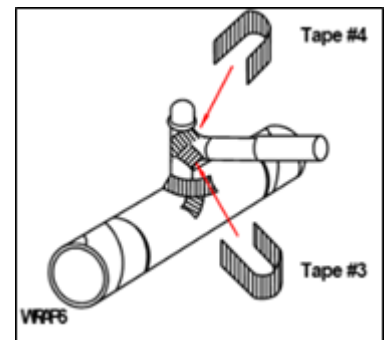

(c) Flash tape #5 and pull down over cap. Center properly so that top edge of cap is completely covered.

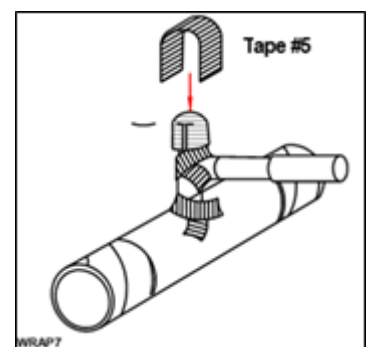

(d) Starting with straight wrap around tee cap, spiral wrap tee and extend at least 2 inches onto undisturbed mill coating. Heat tape so that tar oozes out at overlaps.

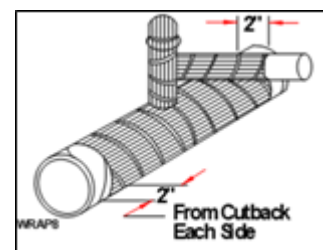

Note: For 6 inches and larger pipe, see [3. A.](#) above for wrapping instructions.

4. *Service Tee Cold Applied Tape:*

- A. Service tees and small fittings can be wrapped with cold applied tape or cold applied wax tape.
- B. The cold applied tapes shall be molded tightly around the fitting so no voids that could collect water remains.
- C. The exposed bare pipe created where the coating was removed to weld the small fitting on to the pipe will require a full encirclement spiral wrap with the cold applied tape.
- D. The cold applied tape shall extend a minimum of 6 inches on to the undisturbed protective coating of the pipe.
- E. When cold applied wax tape is used, care shall be taken when backfilling to prevent the wax tape from being displaced.
- F. Mesh outer wrap can be used to protect the wax tape during backfilling operations.

Appendix I - Specific Coatings

I-1. Tapecoat 20

1. *General*

- A. Tapecoat 20 is a hot-applied 58 mil coal tar tape for ambient temperature below grade application.
- B. Tapecoat 20 consists of a specially formulated pliable coal tar coating completely saturated into and bonded to both sides of a high tensile strength fabric. It has a polyester film adhering to the coating which facilitates unwinding of the roll and acts as an outer wrap providing additional mechanical strength against backfill and soil stress.
- C. Tapecoat 20 should be kept clean and dry prior to application.

2. *Application*

- A. Surface must be clean and dry. Moisture, dust, dirt, rust, or other foreign matter should be removed by scraping or wire brushing. Oil and grease should be removed with a suitable solvent. On previously coated surfaces, remove all loose or incompatible coatings. Use torch to warm the surface and remove moisture prior to priming.
- B. TC Omniprime is the compatible primer for use with Tapecoat 20. Slight stirring of the product may be required prior to use. Apply primer to the prepared surface with a brush, roller, or pad. TC Omniprime should be applied about 3" beyond the area to be wrapped with tape. Let primer dry before applying Tapecoat 20. Allow primer to dry naturally do not use a torch to dry primer. TC Omniprime can also be used on stainless steel.
- C. There are two recommended methods for applying Tapecoat 20 to a properly prepared and primed surface.
 - (1) Spiral Wrap: Flash flame of torch onto the side of the coating without the polyester film (outside of roll) until a smooth and glossy finish is obtained. Apply properly heated coating with tension to the surface of the pipe. Alternately heat and spiral wrap in a single thickness with a continuous overlap of at least 1" of tape.
 - (2) Cigarette Wrap: Precut strips of Tapecoat 20 to a length equal to the circumference of the pipe plus a minimum of about 3 inches for overlap. Follow general tape application instructions described above.

3. Coverage

- A. The following table provides the estimated footage of pipe coated per roll of Tapecoat 20 tape. All rolls are 75 feet in length.

Pipe Size	2" Width 12 Rolls Per Car-ton	4" Width 8 Rolls Per Car-ton	6" Width 4 Rolls Per Car-ton
¾"	39.8'		
1"	31.8'		
1 ½"	22.0'		
2"	17.6'		
3"	11.9'	25.6'	
4"	9.3'	19.9'	
6"		13.5'	
8"		10.4'	15.9'
10"		8.3'	12.8'
12"		7.0'	10.8'

Note: See Appendix [A-1](#) and [A-2](#) for girth weld coating requirements.

- B. TC Omniprime (49 22 084) coverage is approximately 300 sq. ft. per gallon..

I-2. Densotherm Tape

1. General

- A. Densotherm Tape is a hot applied 79 mils bituminous tape. It is comprised of a non-woven synthetic fabric fully impregnated and coated with a flexible, high melting point bitumen compound.

2. Application

- A. Clean all bare steel minimally removing all disbonded foreign matter such as dirt, rust, scale, etc. A suitable solvent clean may be necessary where foreign matter exists.
- B. If moisture exists, heat the surface with a propane torch so as to remove all moisture from the steel. When working on operating gas pipeline in warmer temperatures, wiping with rags may become more practical when removing moisture from the pipe surface.
- C. Apply a uniform coat of Denso Primer D to the pipe surface extending about 3 inches onto the coating on both sides of the weld area. Allow the primer to get tacky and/or dry to the touch. Heating of the pipe should be done before the application of primer. It is not necessary to apply additional heat over the primer. Continuous brushing of the surface, without adding additional primer to the brush, will help with the drying process. Given that the steel surface is warmed initially, primer should only take 3-5 minutes to get tacky or dry to the touch.
- D. Generously heat one side of the Densotherm Tape with a wide-mouthed propane torch, so as to create a glossy, wet, drippy look surface of bitumen.
- E. Wrap the Densotherm hot applied tape over the pipe with the heated side placed against the pipe surface. In cold weather application, heat over the outside portions of the tape where overlaps occur. Apply the tape with a certain degree of tension leaving no mislaps or unbonded areas during the application. A spiral-wrap application is pre-

ferred; however, on larger pipe a cigarette wrap of strips may be more practical. A bead of bitumen should be in place where overlaps in tape occur, thus assuring for good application.

- F. Make sure that the tape extends over the area being wrapped and onto the mill coating a minimum of about 3 inches on either side of the area being wrapped. At least a 1 inch overlap of tape is preferred.
- G. Once applied to the pipe, flash the exterior of the tape surface with plenty of heat so as to witness the lap seams fusing together. Apply a significant amount of heat when glossing over the product with heat. Backfill can occur immediately after the tape has cooled.
- H. On directional drilled bores, it is best to wrap towards the direction with which the pipe will be pulled. Follow the procedure outlined in steps (a)-(d) above, with the one exception of heating and seaming the lead edge until it is flush with the pipe surface. A sacrificial piece of tape may be applied over the lead edge to help prevent any roll-back of the tape.

3. Coverage

- A. The following table provides the estimated footage of pipe coated per roll of Densotherm Tape. All rolls are 50 feet in length.

Tape Width	Rolls/Case	With 1" Overlap
2"	12	45 sqft/case
4"	6	75 sqft/case
6"	4	82 sqft/case

Note: See Appendix [A-1](#) and [A-2](#) for girth weld coating requirements.

- B. Denso Primer D (49 17 762) coverage is approximately 592 sq. ft. per 1.3 gallon container.

I-3. Tapecoat H35

1. General

- A. Tapecoat H35 is a 35 mil cold-applied tape for above and below grade application with an integrated primer. Tapecoat H35 is composed of a gray specially formulated MAF® backing with a synthetic elastomeric adhesive.

- B. No wrinkles in cold tape shall be left. All wrinkles must be cut out and re-taped.

2. Application

- A. Prepare Surface - Surface must be clean and dry. Loose rust, scale, dirt or dust must be removed. A "Tack Cloth" for removal of fine dust particles is provided in each carton. Oil, grease and all other residue should be removed with a suitable solvent.

- B. Apply Primer - Brush apply TC Omniprime and allow primer to dry to a tacky consistency before applying tape.

- C. Apply Tape - There are two recommended methods for applying Tapecoat H35 to a properly prepared surface.

- (1) Spiral Wrap: Tapecoat H35 is hand applied by removing the release liner and spirally wrapping in a single thickness with a continuous 1 inch overlap of tape. Apply enough tension to obtain conformity to surface being wrapped. Apply final wrap without tension.

- (2) Cigarette Wrap: Precut strips of Tapecoat H35 to a length equal to the circumference of the pipe plus a minimum of 4". Follow general tape application instructions described above.

3. Coverage

- A. The following table provides the estimated footage of pipe coated per roll of Tapecoat H35 tape. The 2 inches and 4 inches wide rolls are 75 feet in length. The 6 inches rolls are 50 feet in length.

Footage of Pipe Wrapped per Roll of Tapecoat H35			
Pipe Size	2" Width 12 Rolls Per Carton	4" Width 8 Rolls Per Carton	6" Width 4 Rolls Per Carton
3/4"	24.8 ft		
1"	19.8 ft		
1-1/4"	15.7 ft		
1- 1/2"	13.7 ft		
2"	11.0 ft	32.9 ft	
3"	7.4 ft	22.3 ft	
4"	5.8 ft	17.3 ft	18.5 ft
6"	3.9 ft	11.8 ft	12.5 ft
8"	3.0 ft	9.1 ft	9.6 ft
10"		7.3 ft	7.7 ft
12"		6.1 ft	6.5 ft

- B. TC Omniprime (49 22 084) coverage is approximately 300 sq. ft. per gallon.

I-4. Denso Butyl 35

1. General

- A. Denso Butyl 35 is a heavy duty polyethylene backed tape with a butyl rubber adhesive.
- B. No wrinkles in cold tape shall be left. All wrinkles must be cut out and re-taped.

2. Application

- A. Prepare Surface - Prepare surfaces by removing all loose scale, rust or other foreign matter. Surface must be clean, dry and free of grease.
- B. Apply Primer - Apply a thin uniform coat of Denso Butyl Primer to clean dry surfaces to be wrapped and allow to tack dry. Prime only areas to be wrapped the same day. Reapply primer if the area becomes dirty or wet.
- C. Apply Tape - Peel back interleaving and apply adhesive side of the tape to the surface and press down. Apply the tape spirally with enough tension to make it conform. Remove interleaving as wrapping proceeds. Overlap each turn by at least 1 inch. (Note: When proper surface prep is not achievable or when applying to pitted pipe, apply a thin film of Denso Butyl Primer to all surfaces to be wrapped and allow to dry.) Irregular surfaces such as valves, flanges, etc. may require use of Denso Profiling Mastic.

3. Coverage

- A. The following table provides the estimated footage of pipe coated per roll of Densotherm Tape. All rolls are 50 feet in length.

Footage of Pipe Wrapped per Roll of Denso Butyl 35			
Pipe Size	2" Width 24 Rolls Per Case	4" Width 12 Rolls Per Case	6" Width 8 Rolls Per Case
3/4"	16.5 ft		
1"	13.2 ft		
1-1/4"	10.5 ft		
1-1/2"	9.1 ft		
2"	7.3 ft	21.9 ft	
3"	5.0 ft	14.9 ft	
4"	3.9 ft	11.6 ft	18.5 ft
6"	2.6 ft	7.9 ft	12.5 ft
8"	2.0 ft	6.0 ft	9.6 ft
10"		4.8 ft	7.7 ft
12"		4.1 ft	6.5 ft

- B. Denso Butyl Primer (49 22 393) coverage is approximately 61 sq. ft. per quart

I-5. Moisture Cured Wrap

1. General

- A. Moisture cured wrap (MCW) is a fiberglass cloth impregnated with water activated resins which, when cured, provides a protective outer layer over fusion bonded epoxy (FBE), field applied epoxy coating, hot applied tape or cold applied tape.
- B. The MCW is UV stable so it is not degraded when exposed to sunlight.
- C. The primary use of MCW is to provide an abrasive resistant overcoat on girth weld joints on pipe that is being installed by directional drilling or conventional boring operations where the steel pipe 2 inches nominal diameter and larger is being pulled back through the bore hole. See [Appendix A-2](#) for directional drilling installation
- D. Since MCW is UV stable, it can also be used as a protective overcoat over all of the other approved coating materials at the soil to air interface zone on steel pipe risers. See [Section 4.6](#) Soil to Air Interface Zone

2. Application Procedures for Girth Welds

- A. Prior to the application of MCW, the girth weld joint area on steel pipe 2 inches nominal diameter and larger must be coated with liquid epoxy coating or hot applied tape as shown in Appendix A-1 and A-2.
- B. The coated area shall be inspected to ensure there has been no damage to the coating and the coating is free of dirt, debris or other contaminants.
- C. Roughen the factory FBE or Abrasive Resistant Overcoat (ARO) outer surface adjacent to the girth weld area where the MCW will be applied. A wire brush, sandpaper or similar item can be used to roughen the FBE or ARO surface.

Care must be taken not to remove the FBE coating completely.

- D. See the MCW Coverage Table below for an estimate of the number of rolls required for each pipe size.
- E. Protective gloves, such as nitrile glove (stock code 49 04 553) or latex, should be worn during the installation of MCW.
- F. The roll of MCW should be submerged in water for approximately thirty (30) seconds.
- G. Begin the wrapping immediately after the MCW is removed from the water.
- H. Start the wrapping approximately 12 inches from the girth weld joint, toward the end of the pipe that will enter the bore hole first.
- I. Start by making one complete wrap around the pipe before starting the spiral wrap.
- J. Maintain tension on the wrap so that the MCW is tight against the pipe.
- K. Wet the tape between layers.

A misting of water with a spray bottle is a good method for evenly wetting the tape between layers **as wrapping progresses**.

- L. Following the one complete wrap, begin spiral wrapping the MCW across the girth weld area.
- M. Each spiral wrap should have an approximate 50% overlap.
- N. Stop the spiral wrap approximately 12 inches from the girth weld joint and change the direction of the spiral wrap.
- O. The spiral wrap should progress back across the first spiral wrap layer, again with an approximate 50% overlap, ending at the starting point of the first MCW layer.
- P. **Make** a complete wrap around the pipe with an approximate 100% overlap.
- Q. The end result of the two spiral passes, at an approximate 50% overlap, is a protective coating of 4 full layers of MCW.

3. *Completion and Curing of MCW Wrap*

- A. Following the MCW wrap process, there are 2 completion procedure options available:
 - (1) A polyethylene/stretch wrap can be applied over the just applied MCW wrap resulting in smooth/shiny surface of the complete MCW wrap. With a wire brush or other tool puncture the stretch wrap approximately every square inch and leave until the MCW has cured. **OR**
 - (2) Utilizing the Protal liquid epoxy or the supplied end adhesive packet, coat each end of the wrap to prevent any unraveling of the MCW overcoat until the MCW has cured.
- B. If the polyethylene/stretch wrap was used It shall be removed after the MCW has cured.

- C. Curing time is usually around 45 minutes but this is dependent on the weather temperature. The cure time may be longer when the weather is cold or shorter in extremely high temperatures.

The MCW should be allowed to fully harden before the pipe is pulled into the bore hole.

4. *Application Procedures at Soil Air Interface Zone*

- A. MCW can be installed as UV resistant coating over an approved underground coating that extends above grade. The MCW coating should extend approximately 12 inches below grade to above grade.
- B. Prior to installation:
 - a. The area to be coated with MCW should be cleaned and be free of dirt, debris or contaminants.
 - b. The existing coating should be inspected and repaired if necessary.
 - c. Roughen the factory FBE outer surface where the MCW will be applied. Care must be taken not to remove the FBE coating completely.
- C. Select the correct roll size to allow for a complete application with a single roll. See the MCW Coverage Table below.
- D. Protective gloves, such as nitrile glove (stock code 49 04 553) or latex, should be worn during the installation of MCW.
- E. The roll of MCW should be submerged in water for approximately 30 seconds.
- F. Begin the wrapping immediately after the MCW is removed from the water.
- G. Start the wrapping above grade. Make one complete wrap around the pipe before starting the spiral wrap.
- H. If an above grade valve is less than 12 inches above grade, start the wrap just below the valve making sure there is a good seal between the MCW and the pipe.
- I. Maintain tension on the wrap so that the MCW is tight against the pipe.
- J. Wet the tape between layers. A misting of water with a spray bottle is a good method for evenly wetting the tape between layers.
- K. Following the one complete wrap, begin spiral wrapping the MCW downward. Each spiral wrap should have an approximate 50% overlap.
- L. Stop the spiral wrap approximately 12 inches below grade and change the direction of the spiral wrap.
- M. The spiral wrap should progress back across the first spiral wrap layer, again with an approximate 50% overlap, ending at the starting point of the first MCW layer with a complete wrap around the pipe with an approximate 100% overlap.
- N. Follow the procedures in 3. Completion and Curing of MCW Wrap once the wrapping has been completed.

5. *Moisture Cured Wrap (MCW) Coverage Table:*

Length of MCW Area	Pipe Diameter	Material Required for 50% Overlap and 2 Passes (ends up with 4 layers)	Rolls Per Joint	Roll Size
18" - 24"	2	780 in ²	<1	4" x 27' 4" x 30;
18" - 24"	3	1,144 in ²	<1	4" x 27' 4" x 30;
18" - 24"	4	1,206 in ²	1	4" x 27' 4" x 30;
18" - 24"	6	1,810 in ²	2	4" x 27' 4" x 30;
18" - 24"	8	2,413 in ²	2	4" x 27' 4" x 30;'
18" - 24"	12	3,619 in ²	3	4" x 27' 4" x 30'
			1	8' x 40' 9" x 40'
18" - 24"	14	4,222 in ²	4	4" x 27' 4" x 30'
			1	8" x 40' 9" x 40'
18" - 24"	16	4,825 in ²	4	4" x 27' 4" x 30'
			2	8" x 40' 9" x 40'
18" - 24"	18	5,428 in ²	5	4" x 27' 4" x 30'
			2	8" x 40'

UNCONTROLLED IF PRINTED

				9" x 40'
18" - 24"	20	6,031 in ²	5	4" x 27' 4" x 30'
			2	8" x 40' 9" x 40'
18" - 24"	24	7,238 in ²	6	4" x 27' 4" x 30'
			2	8" x 40' 9" x 40'
18" - 24"	30	10,179 in ²	8	4" x 27' 4" x 30"
			3	8" x 40' 9" x 40'

Note: Estimated MCW material required is based on 24 inches length.

A. Coverage per Roll:

Roll Size	Coverage Square Inches (in ²)
4" x 27'	1,296
6" x 27'	1,944
9" x 40'	4,320

I-6. Tapecoat TC Color Coat - (Not approved for Girth Weld Coating or Pipe Coating Repair)

1. General

A. Tapecoat TC Color Tape, 60 mil, is composed of a fully impregnated fiber carrier saturated with a special formulated blend of waxes and plasticizers that make up this versatile, non-toxic, environmentally safe, easily to apply, protective coating.

2. Application

A. Prepare Surface - Prepare surfaces by removing all loose or non-bonding material, rust scale, dirt, burrs, sharp edges or other foreign matter. Remove excess moisture whenever practical.

B. Apply Primer - Apply a thin uniform coat of TC Color Coat Primer to entire surface with gloved hand, brush, rag, or mechanical mean to a minimum thickness of 2 to 4 mils.

C. Apply Tape - Spirally wrap the tape, a 50 % overlap is preferred, but with a minimum 1" overlap or 20 percent of tape width, whichever is greater, is acceptable if conditions allow. While wrapping, press air pockets out and smooth all lap seams. The cig-

arete wrap method of application may also be used. Irregular surfaces such as valves, flanges, etc. may require the use of profiling material prior to applying tape.

3. Coverage

A. The following table provides the estimated footage of pipe coated per roll of TC Color Coat, with a 50% overlap.

Footage of Pipe Wrapped per Roll of TC Color Coat			
Pipe Size	2" Width 12.5 Feet per Roll	4" Width 25 Feet per Roll	6" Width 25 Feet per Roll
3/4"	4.1 ft		
1"	3.3 ft		
1-1/4"	2.6 ft		
1-1/2"	2.3 ft		
2"	1.8 ft	8.0 ft	
3"	1.2 ft	5.5 ft	
4"	1.0 ft	4.2 ft	7.1 ft
6"		2.9 ft	4.8 ft
8"		2.2 ft	3.7 ft
10"		1.8 ft	3.0 ft
12"		1.5 ft	2.5 ft

Note: 2 inches Roll - 24 rolls/case; 4 inches Roll - 6 rolls/case; 6 inches Roll - 4 rolls/case

I-7. Trenton #2A Wax Tape - (Not approved for Girth Weld Coating or Pipe Coating Repair)

1. General

A. Trenton #2A Wax Tape is a 70 to 90 mil non-woven, non-stitch synthetic fabric, saturated with a blend of microcrystalline wax, solvents and corrosion inhibitors, forming a tape wrapper that firms up and is suitable for painting. The tape is aluminum colored.

2. Application

A. Prepare Surface - Wire brush and wipe surface clean of any loose coating, rust, scale and foreign matter.

B. Apply a thin film of Temcoat Primer by hand directly to the surface.

(1) Temcoat Primer can be applied to wet or cold surfaces.

(2) At higher temperatures, Temcoat can be applied by brush.

(3) In order to displace moisture and ensure adhesion, rub and press firmly on the primer.

(4) After application of the primer Wax-Tape may be applied immediately.

C. Apply Wrap Wax-Tape using a 1 inch overlap.

(1) On straight pipe apply slight tension to ensure contact to the surface.

(2) On irregular surfaces, allow slack so the tape can be molded into conformity.

(3) While wrapping either surface, press and form the tape so there are no air pockets or voids and so that the tape is in intimate contact with the surface.

- (4) Press and smooth out lap seams to ensure that they are sealed.
 - (5) Mesh outer wrap can be used to protect the tape during backfilling operations.
 - (6) Wax-Tape does not require dry time, so it can be backfilled immediately.
 - (7) If the tape is going to be painted, allow a few days for it to firm up.
 - (8) Mesh outer wrap can be used to protect the tape during backfilling operations.
- D. Applying Trenton Fill-Putty (profiling material) - Wire brush or and wipe the surfaces clean of dirt, loose rust or old coating and other foreign materials.
- (1) Apply a thin film of Temcoat Primer by hand directly to the surface. Refer to 2. B. above, except profiling material will be applied to the primer.
 - (2) Apply Fill-Putty directly by hand, working the material onto the metal surface ensuring that the putty is “wetting” and adhering to the surface.
 - (3) Continue applying the material in and around the voids, contours and crevices so as to build up an even surface all around the fitting or structure.
 - (4) Overlap the entire application with Trenton’s Wax-Tape.
 - (5) Mesh outer wrap can be used to protect the tape during backfilling operations.

3. Coverage

A. The following table provides the number of rolls of Trenton #2A Wax Tape and gallons of Wax-Tape primer per 100 inches of pipe. The 4 inches and 6 inches rolls are 9 feet in length.

Pipe Diameter	Tape Width	Lineal Footage per Roll		Gallons of Primer/100ft.
		1" overlap	50% overlap	
2"	4"	3.6	2.4	0.5
	6"	6	3.6	
4"	4"	1.9	1.3	1
	6"	3.2	1.9	
6"	4"	1.3	0.9	1.5
	6"	2.2	1.3	
8"	4"	1	0.7	2
	6"	1.7	1	

B. The following table provides the estimated quantity of Trenton Fill-Putty needed for different sized fittings. It is issues in 2 lbs. blocks.

Pipe Diameter	Flanged Joint	Flanged Valve & Dresser Coupling
4"	3.25 lbs.	9.75 lbs.
6"	4.25 lbs.	12.75 lbs.
8"	5.5 lbs.	16.5 lbs.
10"	7 lbs.	21 lbs.
12"	8.5 lbs.	25.5 lbs.
14"	9.5 lbs.	28.5 lbs.
16"	10.5 lbs.	31.5 lbs.

18"	12 lbs.	36 lbs.
20"	13 lbs.	39 lbs.
24"	16 lbs.	48 lbs.
30"	19 lbs.	57 lbs.

Appendix J - Approved Paints for Pipeline Facility Coating.

Paint Type	Stock Code Number	Farm Tap	Small Regulator Station	Pipeline Delivery Station	Transmission Regulator Stations	Town Border Station	L
Sherwin - Williams "Industrial Yellow" ^{2, 3}	30-59-124	X	X	X	X	X	
Sherwin - Williams "Meter Set Grey" ^{2, 3}	30-51-507	X	X	X	X	X	
Sherwin - Williams "Hunter Green" ^{2, 3}	30-51-564	X	X	X	X	X	
Sherwin – Williams "Ameren Medium Green" ^{2, 3}	30-51-652	X	X	X	X	X	
Tnemec Series 73 "Hunter Green" ^{1, 2, 3}	30-10-115	X	X	X	X	X	
Tnemec Series 73 "Meter Set Grey" ^{1, 2, 3}	30-10-114	X	X	X	X	X	
Tnemec Series 1095	Non-Stock	x	x	x	x	x	
Tnemec Primer	30-58-138	X	X	X	X	X	
Tnemec Thinner	30-55-153	X	X	X	X	X	
Rustoleum "Hunter Green", Enamel ⁴	30-09-083						
Sherwin-Williams - Acrylic Modified Enamel "Meter Gray" ⁴	30-51-579						
Red Primer, Enamel ⁴	30-58-071						

1. Two-part paint
2. These types of paint may be brush applied or spray coated.
3. Color options may vary in special applications.
4. Aerosol paint can be used to touch up small coating defects and bolts until a total repaint of the facilities is necessary. Use care to protect other facilities from over spray.

Appendix K - Coating Inspection

K-1. Inspection Methods

Inspection Method	Any Length Diameter < 2"	Length ≤ 100' Diameter ≥ 2"	Length > 100' Diameter ≥ 2"
Jeep	--	--	X
Visual	X	X	X
Touch	X	X	X

K-2. Inspection Voltage

Inspection Voltage		
Average Total Mil Thickness	Min. Test Voltage	Max. Test Voltage
12 - 14	1800	1950
14 - 16	1950	2100
16 - 18	2100	2200
18 - 20	2200	2350
20 - 22	2350	2450
22 - 24	2450	2550
24 - 26	2550	2700
26 - 28	2700	2800
28 - 30	2800	2900
30 - 32	2900	2950
32 - 34	2950	3050
34 - 36	3050	3150
36 - 38	3150	3250
38 - 40	3200	3300
40 - 42	3300	3400
42 - 44	3400	3450
44 - 46	3450	3550
46 - 48	3550	3650
48 - 50	3650	3700
50 - 52	3700	3800
52 - 54	3800	3900
54 - 56	3900	3950
56 - 58	3950	4000
58 - 60	4000	4100

Note: For average thicknesses more than 2 mils thicker or thinner than indicated in the table above contact the Superintendent of Corrosion Control for proper testing voltages.

Appendix L - Protal Applications

1. General

- A. Ameren Illinois Company (AIC) stocks three (3) Denso field applied liquid epoxy coatings; Protal 7125, 7200 and 7300.

- B. These products are used to coat girth welds, weld joint areas, damaged coating areas and below grade fittings.
- C. Application of these products is to be done in accordance with Denso's instructions. See [CORR 3](#) for manufacturer's instructions:
 - (1) Denso Protal 7125 Instructions
 - (2) Denso Protal 7200 Instructions
 - (3) Denso Protal 7300 Instructions
 - (4) Denso Protal Air Cartridge Gun 1000 Setup

2. *Protal 7125*

- A. Specially formulated for use when ambient and pipe surface temperatures are below 50°F.
- B. Should not be applied when pipe temperature is above 68 °F. Protal will not have sufficient time to adhere to pipe.
- C. Apply with any size brush, roller or pad. Cannot be sprayed applied
- D. Shelf Life
 - (1) One year from the manufactured date when stored in original containers.
 - (2) Tubs and pails have a use by date which would be the last day of the month shown.
- E. Target Application Thickness:
 - (1) Final wet film and dry film target thickness is approximately 30 mils with a minimum of 20 mils and maximum of approximately 60 mils.

3. *Protal 7200*

- A. Should only be applied when ambient and pipe surface temperature is 50°F or above.
- B. Apply with any size brush, roller or pad. Can be spray applied in the field or shop.
- C. Shelf Life
 - (1) Two years from the manufactured date when stored in original containers.
 - (2) Tubs and pails have a use by date which would be the last day of the month shown.
 - (3) Should not be allowed to freeze
- D. Target Application Thickness:
 - (1) Final wet film and dry film target thickness is approximately 30 mils with a minimum of 20 mils and maximum of approximately 70 mils.

4. *Protal 7300*

- A. Can be applied to dry, damp or wet pipe surfaces when pipe surface temperature is at or above 32°F
- B. Apply with any size brush, roller or pad.
- C. Shelf Life
 - (1) Two years from the manufactured date when stored in original containers.

(2) Tubs and pails have a use by date which would be the last day of the month shown.

(3) Should not be allowed to freeze

D. Target Application Thickness

(1) Final wet film and dry film target thickness is approximately 30 mils with a minimum of 20 mils and maximum of approximately 60 mils.

5. Protal Coverage Tables

A. Tables below were taken from Denso Protal Liquid Coatings Quantity Estimate Sheet (VER 1608.08).

B. Weld Joints

WELD JOINT COVERAGE (Applied at 25 mils to 30 mils)		
Pipe Diameter	Joints per Liter 2" to 3" Cut Back	Joints per Liter 6" to 8" Cut Back
4"	9	4.5
6"	6	3
8"	4.5	2.5
10"	3.6	2
12"	3	1.5
16"	2.25	1.25
20"	1.8	1
24"	1.5	0.75
30"	1.2	0.625
36"	1	0.5
42"	0.86	0.43
48"	0.75	0.375

C. Bore Joints

C. Bore Joints BORE JOINT COVERAGE (Applied at 45 mils to 60 mils)		
Pipe Diameter	Joints per Liter 2" to 3" Cut Back	Joints per Liter 6" to 8" Cut Back
4"	4.5	2.25
6"	3	1.5
8"	2.25	1.25
10"	1.8	1
12"	1.5	0.75
16"	1.125	0.625
20"	0.9	0.5
24"	0.75	0.375
30"	0.6	0.312
36"	0.5	0.25
42"	0.43	0.215
48"	0.375	0.188

D. Product Coverage

PRODUCT COVERAGE		
Thickness (mils)	Theoretical Coverage (SF per Liter)	Actual* Coverage (SF per Liter)
20	21	14

UNCONTROLLED IF PRINTED

25	17	11.5
30	14	9.5
35	12	8
40	10.5	7
45	9.5	6.5
50	8.5	5.5
55	7.5	5
60	7	4.5

* Actual coverage to be determined by applicator

Appendix M, Epoxy Coating for Submerged Facilities

Denso Item	Stock No.
SeaShield 525 - Epoxy	4922506
SeaShield 526 - Epoxy	4922505

CORROSION CONTROL

May 15, 2022

CORR 2.4 Corrosion Protection Criteria

1.0 Purpose

This document provides the criteria for the measurement of the effectiveness of the cathodic protection on Ameren Illinois (AIC) pipelines and facilities. This document meets the requirements of 49 CFR Part 192 Appendix D.

2.0 Scope

This document addresses the following:

[3.0 Target Audience](#)

[4.0 General](#)

[5.0 CP Criteria](#)

[6.0 IR Drop Measurement](#)

[7.0 IR Drop Testing Methods](#)

[8.0 Conducting the IR Drop Survey](#)

[9.0 Hydrogen Generation Under Coatings](#)

Appendices:

[Appendix A - Measuring Cathodic Protection Potentials](#)

3.0 Target Audience

- Corrosion Control Supervisors
- Corrosion Control Specialists

4.0 General

A "go" or "no go" decision for cathodic protection adequacy cannot be made based solely on the pipe-to-soil value measured.

4.1 Interpreting pipe-to-soil measurements from a pipeline system requires:

4.1.1 Knowing how and where the reading was obtained.

4.1.2 Selecting the appropriate criteria, obtaining the measurement using proper techniques, and properly evaluating the measurement by corrosion personnel are dictated by economics and safety.

4.1.3 Pipe-to-soil measurements with protective current applied may be appropriate for distribution systems with galvanic anode systems.

4.1.4 A poorly coated structure with an impressed current system is often a good candidate for the 100 mV polarization shift criteria.

4.2 The appropriate criterion must be selected, acceptable test methods must be used, and the measurements must be evaluated properly by trained personnel.

UNCONTROLLED IF PRINTED

4.3 The accuracy of the measurement and the economics of obtaining the data must be weighed when selecting a criterion.

5.0 CP Criteria (49 CFR Part 192 Appendix D)

5.1 -850 mV (-0.85 V) Pipe-to-Soil Potential (49 CFR Part 192 Appendix D subsection I A (1))

5.1.1 A negative cathodic protection potential of at least -850 mV is considered adequate for protection of mains and services.

5.1.2 Voltage (IR) drops other than those across the structure electrolyte boundary must be considered for valid interpretation of the voltage measurement.

5.2 -850 mV (-0.85 V) Polarized Potential

5.2.1 A negative polarized potential of at least -850 mV with the interruption of the cathodic protection current is considered adequate. Potentials are measured on regular cycles to identify a minimum "on" potential required to maintain the "instant off" potential of at least -850 mV.

Use of polarized potential criteria requires that all sources of cathodic protection current must be simultaneously interrupted.

5.3 100 mV Polarization Shift (49 CFR Part 192 Appendix D subsection I A (3))

5.3.1 A minimum of 100 mV of cathodic polarization is considered adequate. To determine polarization:

1. A potential of the native potential must be measured.

A native potential is defined as the potential measured prior to activation of the cathodic protection system.

2. After CP current is applied and the pipe is allowed time to polarize, the CP current is interrupted and an instant off potential is measured.

3. If the instant off potential is more than 100 mV less negative than the native potential then cathodic protection is adequate.

1. This method can be used on systems with coating degradation, bare pipe, or insufficient current between rectifiers.
2. This method can only be used on a system where all current sources can be disconnected and interrupted.

Example:

Instant off Potential	-780 mV
Native Potential	-650 mV

Difference -130 mV (Cathodic Protection Adequate)

5.4 100 mV Polarization Decay

5.4.1 A minimum of 100 mV polarized decay is considered adequate. To determine polarized decay:

1. An "instant off" measurement is captured within 0.1 to 0.4 seconds after the current is switched off. See "[Monitoring and Maintenance of Conductive Coating Anode Cathodic Protection Systems](#)" in the Reference Documents section and [Figure 1](#).
2. Then the CP current is interrupted for an extended period of time of 8 to 24 hours.
3. If the polarized decay potential is more than 100 mV less negative than the "instant off" potential then the cathodic protection is adequate. See note in [Section 5.3.1](#).

Example:

Instant off Potential	-780 mV
Depolarized Potential	-620 mV
Difference	-160 mV (Cathodic Protection Adequate)

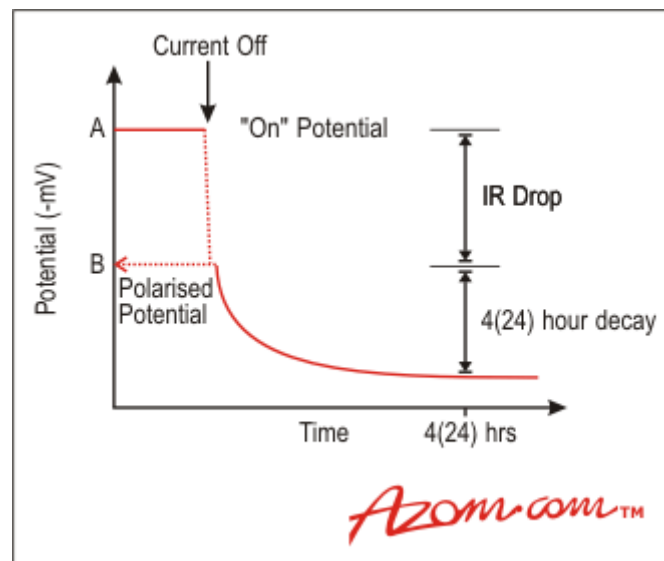

Figure1. Potential Decay Curve

5.5 Other Criteria for Protection of Steel

5.5.1 A voltage at least as negative (cathodic) as that established at the beginning of the Tafel segment of the E-log-I curve. See 49 CFR 192 Appendix D subsection I A (4) and Figure 2.

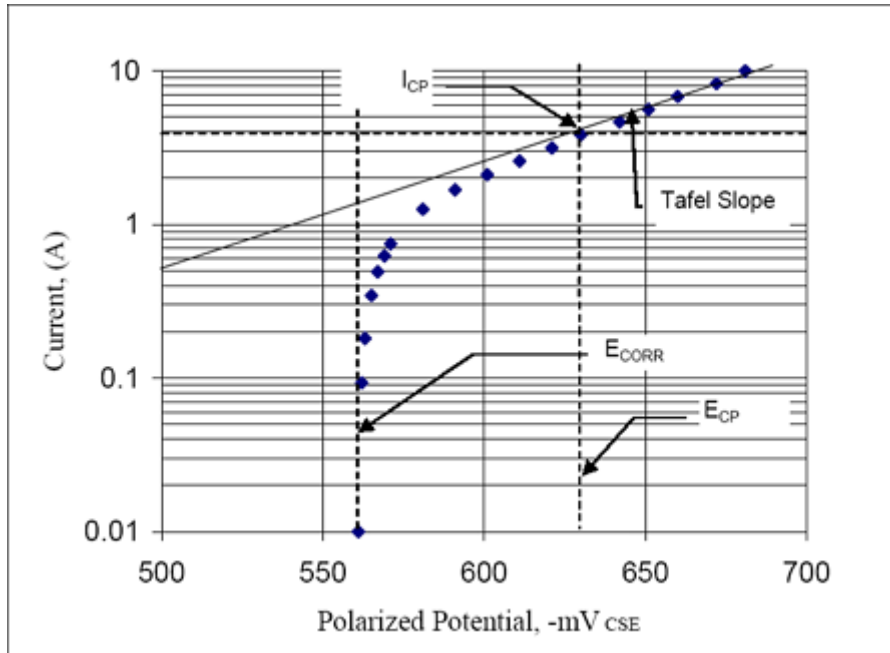

Figure 2. E-log-I Curve showing Tafel Slope

5.5.2 A net protective current from the electrolyte into the structure surface measured by an earth current technique applied at predetermined current discharge (anodic) points of the structure.

6.0 IR Drop Measurement

6.1 Each potential measured has several components which include:

- 6.1.1 Potential of the pipe
- 6.1.2 IR drop in the metallic circuit
- 6.1.3 IR drop in the soil/pipe circuit

6.2 Two of the three potential components, 6.1.2 and 6.1.3, are caused by current flow from the cathodic protection system. See [Figure 3](#) for a Cathodic Protection Current Flow Diagram.

In such cases, the IR drop consists of a resistance (pipe or earth) and a current from the cathodic protection system. If the current becomes zero, additions to the potential should each read zero and not affect the measurement. When current flow is small, the error is small.

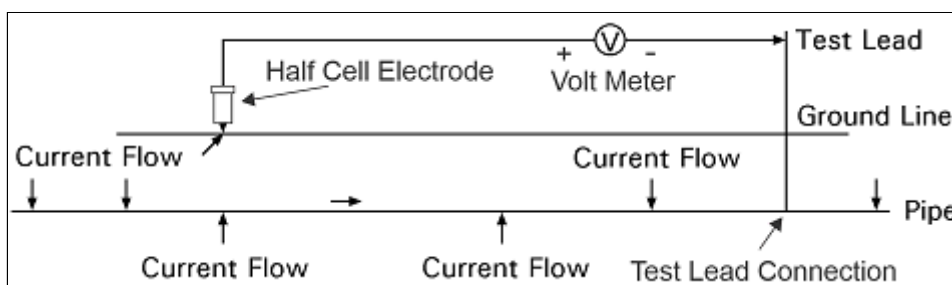

Figure 3. Cathodic Protection Current Flow Diagram

UNCONTROLLED IF PRINTED

6.3 Methods for Considering IR Drop Error

- 6.3.1 Review leakage caused by corrosion on protected mains and services annually and document.
- 6.3.2 Use a more negative "on" criterion.
- 6.3.3 Interrupt current flow and measure the pipe-to-soil potential before the structure begins to depolarize.
- 6.3.4 Measure the potential as close as possible to the pipe and soil interface. See [Appendix A](#) - Measuring Cathodic Protection Potentials.
- 6.3.5 Remote earth potentials.
- 6.3.6 Extrapolation (using mathematical formulas to calculate the potential at the pipe and soil interface).
- 6.3.7 Ignore if error is not significant.

7.0 IR Drop Testing Methods

7.1 Galvanic Anode Systems or Impressed Current Systems

- 7.1.1 When possible, measure potentials at pipe and soil interface remote to anode installations. Installations include:
 - 1. Service risers
 - 2. Pressure control station risers

7.2 Interrupted survey process for Impressed Current Systems

- 7.2.1 Use synchronized interrupters at current sources to perform current interruptions when pipe exam data or leak data indicates that -0.85 V "on" is not adequate. See Figure 4.



Figure 4. Current Interrupter

- 7.2.2 Measure the "instant off" potential. An "instant off" is considered to be a potential measured between 200 milliseconds and 3 seconds after the current flow has been interrupted. Set the interrupter open time to closed time at a ratio of 1 to 3.
- 7.2.3 Capture the potential. Use a recording multimeter and set the record feature at the 100-millisecond recording rate. Measure the "on" potential with the handheld data collection device and the "off" potential with the recording in the record mode.

7.3 Using the recording multimeter

UNCONTROLLED IF PRINTED

7.3.1 Connect the meter to half-cell and pipeline test station.

7.3.2 Push the min/max button. See Figure 5.



Figure 5. Recording Multimeter

7.3.3 Record for at least 2 interrupter cycles.

7.3.4 Push the min/max button to retrieve minimum and maximum potentials.

7.3.5 After the initial interruption, the recording meter shall measure at least 9 potentials during the first second after the interruption, missing the anodic spike.

7.3.6 Check the potentials to verify that the spike has been missed. See [Figure 6](#) for typical pipe-to-soil potential after current interruption.

7.3.7 The recording meter shall record data for at least 2 complete interrupter cycles.

The min/max button on the meter recalls the minimum, the maximum, and the average potentials.

7.3.8 The maximum potential is the "instant off" (red lead is to the pipe and the black lead to the half cell). The potential should be within -0.85 V and -1.5 V.

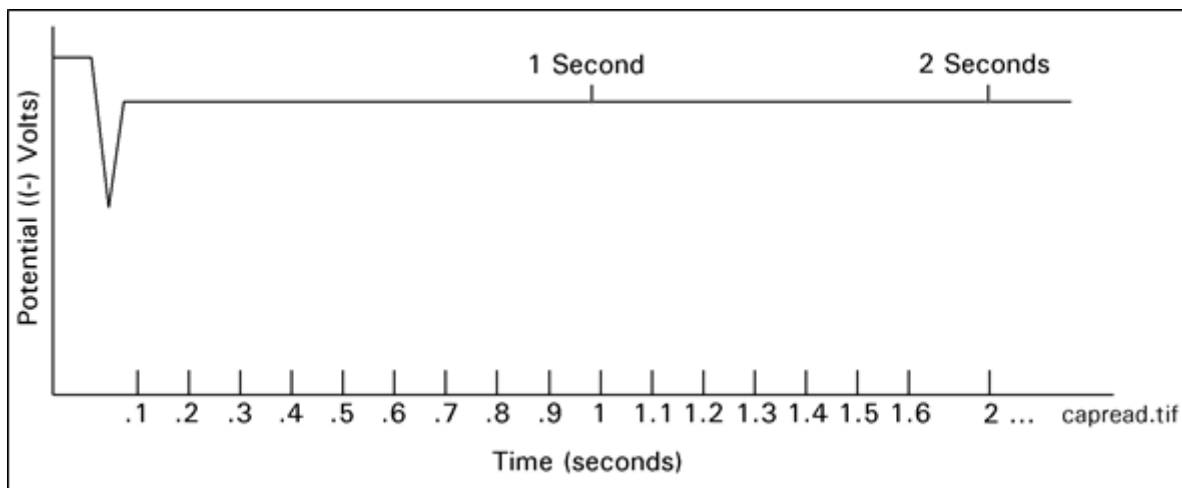

Figure 6. Typical Pipe-to-Soil Potential after Current Interruption

8.0 Conducting the IR Drop Survey

8.1 Identify the current sources to interrupt such as:

8.1.1 Rectifiers

8.1.2 Anode beds

8.1.3 Bonds

8.1.4 Foreign rectifiers.

8.2 Test or estimate the extent of each sources influence.

8.3 Synchronize the necessary number of interrupters and place them at the current source.

On rectifiers, it may be easier to remove a tap bar and interrupt between the center tap and the operating tap on the AC side of the rectifier.

Be aware of the drift of the type of interrupter used. For quartz crystal-controlled interrupters, if using a 1 or 2 second open, reset the interrupters every day. If using a 3 second open, reset them every other day.

Generally, the batteries in the interrupters last at least 2 days.

8.4 Proceed to each test station and measure an "on" potential and an "off" potential.

8.5 Remove the interrupters from the current sources.

9.0 Hydrogen Generation Under Coatings

- 9.1 On well-coated pipelines, hydrogen can be generated at polarized potentials above -1.2 V after considering IR drop and may disbond coatings in the area around holidays. Some coatings are more susceptible to damage than others.
- 9.2 When coating damage is discovered that involves blistering or severely disbanded coating centered on a small holiday, over-voltage shall be investigated.
- 9.3 All current sources shall be interrupted to determine the over-voltage potential at a given test station.
 - 9.3.1 For example, if shorted through a regulator station to a galvanic anode system, the "instant off" may be above -1.2 V and not have an over-voltage condition.

It is not uncommon to encounter an "instant off" potential more negative than -1.2 V since voltage gradients from other facilities or unknown current sources can affect the potentials measured when the target line CP systems are interrupted.

- 9.4 No current shall be applied that will increase the 'on' potential more negative than -3.00 V without performing an over-voltage investigation.

End of Instructions.

Operator Qualification (OQ) Required?

Yes.

- 0001: Measure Structure- to-Electrolyte Potential
- 0011: Conduct Close Interval Survey
- 0021: Measure Soil Resistivity
- 0031: Inspect and monitor Galvanic Ground Beds/Anodes
- 0041: Installation and Maintenance of Mechanical Electrical Connections
- 0051: Installation of Exothermic Electrical Connections
- 0061: Inspect or Test Cathodic Protection Bonds
- 0071: Inspect or Test Cathodic Electrical Isolation Devices
- 0081: Install Cathodic Protection Electrical Isolation Devices
- 0091: Troubleshoot In- Service Cathodic Protection System
- 0101: Inspect Rectifier and Obtain Readings
- 0111: Maintain Rectifier

Appendices

[Appendix A - Measuring Cathodic Protection Potentials](#)

Attachments

NONE.

UNCONTROLLED IF PRINTED

Compliance Requirements

49 CFR Part 192 Appendix D - Criteria for Cathodic Protection and Determination of Measurements

Reference Documents

[Monitoring and Maintenance of Conductive Coating Anode Cathodic Protection Systems](#) (online reference)

Document Rescission

CORR 2.4 Corrosion Control: Cathodic Protection Criteria, October 1, 2020

Revision Notes

Location of Changes	Summary of Changes
Paragraph 4.1.2	Grammatical – "properly evaluating the measurement"
Appendix A – Measuring Cathodic Protection Potentials	3. C. – Spelling correction – half-cell 3. C. (2) – Grammatical – In case of dry soil, add water to the half-cell placement site 4. B. – Added – Figure 2. Copper Sulfate Reference Cell 4. B. – Added – For M.C. Miller Half-Cell

Appendix A - Measuring Cathodic Protection Potentials

1. General

- A. Adequate cathodic protection levels are required by 192 Subpart I section of the federal pipeline safety regulations and extend the life of pipeline assets.
- B. Tests are performed on steel pipeline systems to determine whether cathodic protection levels are adequate to mitigate external corrosion.

2. Measuring Cathodic Protection Potentials

- A. Cathodic protection potentials are measured with a direct current (DC) voltmeter and referenced to a copper/copper sulfate half-cell electrode.
- B. The voltmeter should be connected as follows:
 - (1) Negative (-) lead to the reference electrode.
 - (2) Positive (+) lead to the pipe or test lead.
- C. Measuring a pipe-to-soil (P/S) potential requires two connections, one to the pipe and one to the soil.
 - a. Both connections require meter test leads which are in good condition.
 - b. The connection to the pipe requires a good contact to clean metal. The connection to the soil requires a properly filled and maintained half-cell plus some moisture in the soil to complete the contact.
 - c. The soil surface also needs to clear of foreign materials and the half-cell should be placed as closely as possible to directly over the pipe.

UNCONTROLLED IF PRINTED

- d. There are some conditions that make this half-cell connection difficult. Some examples of these conditions are: frozen soil, dry soil, concrete, asphalt and landscaping materials.
- e. Measurements taken on any of these surfaces without special precautions may have errors in them.

3. *Procedures for Measuring Cathodic Protection Potentials*

A. *AC Voltage Sensing Device*

- (1) Ensure that the AC voltage sensing device is functioning properly.
- (2) Test structure for AC voltage prior to touching it.

B. *Digital Multimeter with Half-Cell*

- (1) Connect leads from voltmeter.
 - (a) Red lead to volt/ohm terminal.
 - (b) Black lead to common terminal.
- (2) Select VDC (volts DC) choice on voltmeter
- (3) Connect the clip end of the red lead to the pipe or structure to be tested.
- (4) Connect the clip end of the black lead to the half-cell.
- (5) Remove the orange protective cap from the reference electrode.
- (6) Place the porous plug of the electrode into moist soil.
- (7) Observe and record the reading to at least 2 decimal places.

C. Proper half-cell placement is critical to gathering high quality pipe to soil measurements in the field. Taking special precautions during the placement of the half-cell will minimize errors introduced at this connection point. Special precautions for obtaining P/S readings for:

(1) *Frozen soils*

Frozen soil does not allow the half-cell to make good contact with the soil and has very high resistance compared to unfrozen soil. During the times of year when there is frost (frozen soil) in the ground, it is often still possible to find frost free soil next to home or business foundations where good contact can be made with the half-cell. However, if frozen soil is encountered at any location where a pipe to soil is required, a hole must be made through the frozen soil and water added to the hole before the measurement is taken. If the top layer of soil is melted, but the soil still frozen underneath, a hole through the frozen soil and the addition of water is still required for taking pipe-to-soil measurements.

(2) *Dry soil*

In case of dry soil, add water to the half-cell placement site. It may be necessary to break a dry crust prior to adding water.

(3) *Asphalt*

Pipe-to-soil measurements cannot be taken on unbroken asphalt. If there are cracks with vegetation, this indicates that the crack is open to the soil below and the half-cell may be placed on the crack to obtain the measurement. Sometimes the addition of water to the crack will facilitate good contact between the half-cell and the soil below.

(4) **Concrete**

Pipe-to-soil measurements should not be taken on unbroken concrete. If there are cracks with vegetation, this indicates that the crack is open to the soil below and the half-cell may be placed on the crack to obtain the measurement. Sometimes the addition of water to the crack will facilitate good contact between the half-cell and the soil below. In extreme cases, a water saturated sponge may be used to facilitate half-cell contact with the concrete but in these cases it is recommended to contact the Corrosion Control Supervisor to determine if a more negative potential is required to allow for error that is often introduced by the alkalinity of the concrete.

(5) **Landscaping materials such as rock or bark**

These materials prevent good half-cell contact and there is often an isolating barrier of polyethylene sheet. To make good half-cell contact, the polyethylene barrier must be breached and the half-cell placed on soil.

4. **Equipment**

A. **Multimeter**

- (1) The Multimeter has a range of applications which include voltage, current, and resistance measurements.
- (2) Meter requirements
 - (a) Minimum of 10 mega ohm input resistance
 - (b) Measures AC and DC voltage
 - (c) Measures DC mV
 - (d) Measures resistance
 - (e) Ability to test diodes

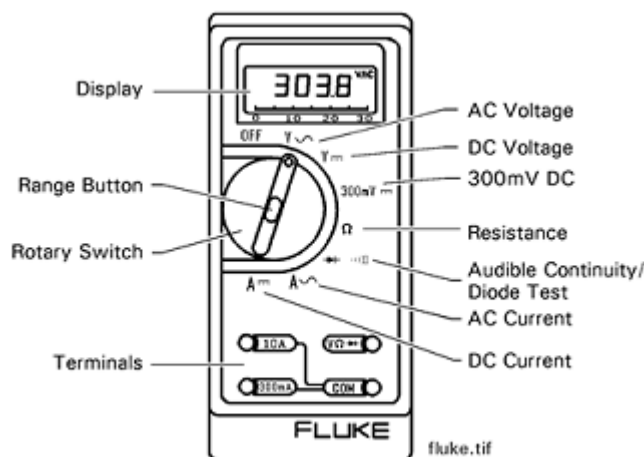

Figure 1 -Typical Multimeter

(3) **Measurements**

Follow manufacturer's instructions for performing testing. Always use insulated probes and clips and check for AC prior to connecting.

(4) **Care and Maintenance**

- (a) Regularly inspect leads

- (b) Change battery
- (c) Consult manufacturer's instructions

B. Copper Sulfate Reference Electrode

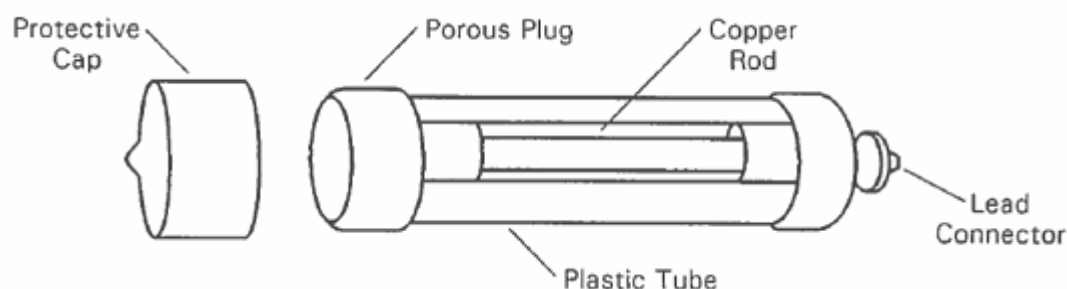

Figure 2. Copper Sulfate Reference Cell

Item	Stock Code	
Complete Half-Cell	84 28 040	M.C. Miller RE-5
Porous Plug	19 15 859	For M.C. Miller Half-Cell
Copper Sulfate Crystals	31 53 202	For M.C. Miller Half-Cell
Anti-freeze	14 12 292	For M.C. Miller Half-Cell

- (1) The copper sulfate reference electrode as received contains no liquid. Blue copper sulfate crystals are in the plastic tube.
- (2) To prepare the electrode for use, remove plastic cap and copper rod.
 - (a) Fill the electrode tube to the top with distilled water.
 - (b) Replace copper rod assembly and tighten plastic cap firmly to effectively seal the tube.
Note: Avoid crystals on threaded portion of the tube.
 - (c) Shake electrode a few times to quickly obtain a saturated solution. Note: The solution will be blue and some excess copper sulfate crystals should be at the bottom of the tube.
 - (d) After initial filling, allow at least 5 minutes for the porous plug to become saturated before using the electrode.
- (3) The porous plug may leak a few drops of copper sulfate solution until pressure within the tube is equalized with atmospheric pressure. Leave the protective cap off for 2 hours after water has been added. Do not allow leakage, which is corrosive to many metals, to seep into the test equipment. Keep the protective cap on the porous plug when not in use.
- (4) There is also a stop leak anti-freeze gel that is available that could be substituted for the copper sulfate crystals and distilled water.
Warning: Copper sulfate is a POISON. It may be fatal if swallowed. Wash hands thoroughly after handling.
- (5) Low Temperature Precautions

If the temperature is below 32°F, the solution may freeze. If frozen, the internal resistance of the electrode becomes very high, and a correct reading is impossible. If frozen, the plastic tube or porous plug may split. It is recommended that

the cell be filled with antifreeze solution for copper sulfate electrodes during cold weather.

(6) Maintenance

- (a) Maintenance of the electrode consists of adding distilled water to make up for evaporation and ensuring there are excess crystals at the bottom of the tube. Always use high purity, finely divided copper sulfate crystals.
 - (b) After prolonged use, the copper sulfate solution may become contaminated, which causes measurement errors.
-
- Half-cells used sporadically throughout the year should be cleaned and refilled annually.
 - Half-cells used daily should be cleaned and refilled quarterly or when needed.
 - The copper sulfate solution may become cloudy with use. This does not mean the solution has become seriously contaminated.

NOTE:	<i>Use only high-purity finely divided copper sulfate crystals obtained from a reputable supplier such as MC Miller.</i>
--------------	--

CORROSION CONTROL

May 15, 2022

CORR 2.5 CP System Troubleshooting

1.0 Purpose

The purpose of this document is to provide guidance in troubleshooting cathodic protection on the Ameren Illinois (AIC) pipeline system.

2.0 Scope

This document addresses the following:

[3.0 Target Audience](#)

[4.0 General](#)

[5.0 Information Needed to Maintain CP Systems](#)

[6.0 General Troubleshooting Steps](#)

[7.0 Equipment Needed](#)

[8.0 Structure Limit Verification](#)

[9.0 Performing Verification](#)

[10.0 Structure Size](#)

[11.0 Current Requirements](#)

[12.0 Current Requirement Calculation](#)

[13.0 Establishing Required Current](#)

[14.0 Current Interrupters](#)

3.0 Target Audience

- Corrosion Control Supervisors
- Corrosion Control Specialists

4.0 General

- 4.1 CP systems for distribution and transmission pipelines are unique electrical circuits with characteristics based on:
 - 4.1.1 Geometry
 - 4.1.2 Coating quality
 - 4.1.3 Soils
 - 4.1.4 Current source locations
- 4.2 This uniqueness defies simple specific troubleshooting approaches when problems are encountered.
- 4.3 This document contains general approaches that are applied to specific situations to determine the cause and corrective action for the problem.

5.0 Information Needed to Maintain CP Systems

UNCONTROLLED IF PRINTED

5.1 The following information is important in maintaining CP systems:

5.1.1 Type and condition of coating

5.1.2 Type of protection

5.1.3 Points of insulation:

1. Location of insulation and bond wires between protected systems.
2. Status of bond wires (open or closed).
3. Current interchanges where appropriate.
4. Location of any underground structure which crosses or closely parallels the protected system such as water mains, bare steel or cast iron gas mains, and metal culverts.

6.0 General Troubleshooting Steps

6.1 The following approach will work for most CP system problems:

6.1.1 Identify the structure limits.

6.1.2 Perform pipe-to-soil tests across the structure to develop a profile of the system.

6.1.3 Perform a current requirement test and compare to estimated current requirement.

6.1.4 If the current requirement test indicates more current is required than the structure should require, perform short finding investigation using appropriate locating equipment.

6.1.5 Initiate corrective action to eliminate the problem.

6.1.6 Retest the CP structure after the corrective actions are completed.

7.0 Equipment Needed

7.1 Most technicians will need the following items to perform routine cathodic protection troubleshooting and testing work:

7.1.1 Multimeter



Figure 1 Multimeter

7.1.2 AC voltage sensor



Figure 2 AC voltage sensor

- 7.1.3 Spare test leads
- 7.1.4 Insulated clips for the multimeter
- 7.1.5 30" extension rod for the half cell



Figure 3 Extension rod for the half cell - 30 inches

- 7.1.6 Field half cell
- 7.1.7 Low frequency locator
- 7.1.8 12-volt battery
- 7.1.9 Interrupter
- 7.1.10 Rheostat (some interrupters such as the T&R CS 10 combine the interrupter and rheostat)



Or



Figure 4 T&R CS-10 Power Supply with Rheostat

- 7.1.11 Wire leads to connect equipment
- 7.1.12 Pit gauge



Figure 5 Pit Gauge

- 7.1.13 Wire reel with 1500'-2000' of #22 wire (optional, recommended if available)
- 7.1.14 Wire reel with 300' of #18 wire
- 7.1.15 Maps of pipelines to be worked on
- 7.1.16 Basic hand tools that include wire cutters, small wrenches, pliers and screw drivers
- 7.1.17 Soil resistivity instrument



Figure 6 Soil resistivity instrument

- 7.1.18 Spare parts for rectifiers and bonds
- 7.1.19 Copper sulfate antifreeze
- 7.1.20 High-purity finely divided copper sulfate crystals (Stock Code 31 53 202)
- 7.1.21 Sandpaper
- 7.1.22 Wire brush
- 7.1.23 Spare battery style clips with insulating boots

8.0 Structure Limit Verification

- 8.1 A cathodic protection structure is the buried pipeline section which includes:
 - 8.1.1 Electrically continuous welded or bonded sections of pipeline.
 - 8.1.2 Isolated from unprotected structures or other structures not designated as a part of the intended structure.
 - 8.1.3 Pipe protected by either galvanic anodes and/or an impressed current system.

UNCONTROLLED IF PRINTED

Cathodic protection structures are established to provide a method for identifying, maintaining, and monitoring corrosion protection on sections of buried steel piping.

Verification of a structure is testing the continuity in piping to determine structure limits.

8.2 Perform verification to determine:

- 8.2.1 Limits of structures
- 8.2.2 Proper test point placement
- 8.2.3 Number of test points needed
- 8.2.4 If piping is monitored properly

8.3 Verify the structures when discrepancies are found or additional test points are required. Discrepancies include:

- 8.3.1 Services on a structure read substantially different.
- 8.3.2 Maps show insulators where structures indicate continuity.

9.0 Performing Verification

9.1 Use a current interrupter to apply current (or short-out system) and make spot checks along the main at test leads or services for shift in potential.

Potential shift at spot check locations should approximate potential shift at the interrupter. There will be some attenuation (lessening in magnitude) in the readings as the distance from the current source increases.

9.1.1 Document these readings and check all endpoints and insulation points.

9.1.2 Check the entire structure and follow-up on any differences with existing records.

1. A low frequency locator can also be used because the signal will fade at ends or insulators.
2. A short can be created at a meter set anywhere along the structure to draw the signal current to that point.
3. The signal can only go to the short if the pipe is continuous with the pipe where the transmitter is located.

9.1.3 Record:

1. The verification date.

2. Structure footage.
3. Make appropriate changes to maps.
4. Add test points as needed.

10.0 Structure Size

10.1 Distribution structures should be approximately 5,000 - 10,000 lineal feet.

Larger structures are acceptable if no problems are encountered.

10.2 Structures may be broken into smaller components when short location is impeded by structure size or existing piping loops.

10.3 If necessary, reduce structure size by insulating 1-¼ inch and 2 inch taps. On larger diameter mains, such as 4 inch or 6 inch, insulate as a last resort. Insulate electrically continuous loops when possible.

10.4 There is no limit on structure size on transmission or high pressure distribution mains.

11.0 Current Requirements

11.1 Current requirement testing is a diagnostic tool used to determine the amount of current necessary to bring a given structure from an unprotected level to a protected level.

11.2 A current requirement test can be used to determine if a structure is shorted. If applied current is more than calculated current, the system is either shorted or has significant coating problems. The most common cause for a high current requirement is a short.

11.3 Current requirement tests are also performed because coatings deteriorate and anodes deplete as systems age. If the current requirement is reasonable for the structure size, additional protection can be added and short investigating avoided. If the current requirement is too high for the structure, a short is indicated.

11.4 Perform current requirement tests when a structure has inadequate protection for reasons other than an obvious short.

11.4.1 For example, an obvious short may exist when the previous pipe-to-soil readings were -1.35 V and are now -0.68 V, (though this could be due to the anodes being cut off or a bond opened).

11.5 To perform a current requirement test, use a current interrupter and apply current until the pipe-to-soil measurements are raised to a protected level.

11.6 Make spot checks along the main at test leads or services for potential shift. The protection level should rise uniformly over the entire structure. There may be some attenuation away from the current source.

11.7 Record the amount of current flowing onto the structure, from the ammeter on the interrupter, or read the voltage drop on an in-line shunt.

11.8 Compare the reading to the calculated current for the structure. The Corrosion Worksheet can be used to calculate the current requirement. For the purpose of calculating the surface area, the structure footage may be scaled.

12.0 Current Requirement Calculation

12.1 Use the Corrosion Worksheet or a map to record the potentials and current level.

12.1.1 Current Estimates

1. Bare pipe requires a current of 1 mA/sqft. to 3mA/sqft. for protection.
2. New pipe, if the coating is 98% effective, 2% of pipe is bare and requires protection.
 - 2 a. Therefore, 2% of 1 mA/sqft. is 0.02mA/sqft. and should protect new pipe with good coating.
3. Existing pipe
 - 3 a. Coating on existing deteriorates as a result of moisture absorption or mechanical damage.
 - 3 b. Poorly coated service tees also affect the amount of bare metal to be protected.
 - 3 c. For example, if the coating 96% effective, 4% of pipe is bare and requires protection.
 - 3 d. Therefore, 4% of 1 mA/sqft is 0.04mA/sqft and should protect the existing pipe.

$$4. \text{ Surface Area} = \frac{\text{OD inches}}{12 \text{ inches}} \times \pi \times \text{length} \quad (\text{also, add all steel service surface area})$$

5. Surface area of the structure x 0.02mA = approximate current required for new structure.
6. A 17# anode provides approximately 15 mA to 30 mA of current per anode. See [Table 3](#).
7. Example:
 - 7 a. Example 1 - New Structure
 - (i) 2300' of 2" (scaled from map)
 - (ii) 3000' of 4" (scaled from map) of X-tru coated pipe
 - (iii) 105 sections of 3/4" steel service with an estimated average length of 60 ft.
 - (iv) .02 mA/sqft required to protect these sections of pipe.
 - (v) Current requirements as determined by field measurements is 142 mA.
 - (vi) See Table 1 for results

Table 1. Cathodic Protection current requirement for a new structure

Length	OD in Inches	OD in Feet	π	Surface Area - sq ft
Length X OD (in ft) X π = Surface Area				
2300	2.375	0.1979	3.141592654	1430
3000	4.5	0.375	3.141592654	3534
6300	1.05	0.0875	3.141592654	1732
Total surface area =				6696
Total Current (mA)= .02 X Surface Area=				134
Number of 17# anodes in 3000 Ohm-cm soil = Total Current (mA)/30 mA per 17# anode=				4.46
Current requirement from the field =				142
Number of 17# anodes in 3000 Ohm-cm soil = Total Current (mA)/30 mA per 17# anode=				4.73
Note: Use 5 Anodes				

7 b. Example 2 - Existing Structure

- (i) 2300' of 2" (scaled from map)
- (ii) 3000' of 4" (scaled from map) of X-tru coated pipe
- (iii) 105 sections of 3/4" steel service with an estimated average length of 60 ft.
- (iv) .04 mA/sqft required to protect these sections of pipe.
- (v) Current requirements as determined by field measurements is 250 mA.
- (vi) See Table 2 for results

Table 2. Cathodic Protection current requirement for an existing structure

Length	OD in Inches	OD in Feet	π	Surface Area - sq ft
Length X OD (in ft) X π = Surface Area				
2300	2.375	0.1979	3.141592654	1430
3000	4.5	0.375	3.141592654	3534
6300	1.05	0.0875	3.141592654	1732
Total surface area =				6696
Total Current (mA)= .02 X Surface Area=				134
Number of 17# anodes in 3000 Ohm-cm soil = Total Current (mA)/30 mA per 17# anode=				4.46
Current requirement from the field =				142
Number of 17# anodes in 3000 Ohm-cm soil = Total Current (mA)/30 mA per 17# anode=				4.73
Note: Use 5 Anodes				

13.0 Establishing Required Current

13.1 Current Testing Instructions

13.1.1 See Figure 7 for schematic of current test set up.

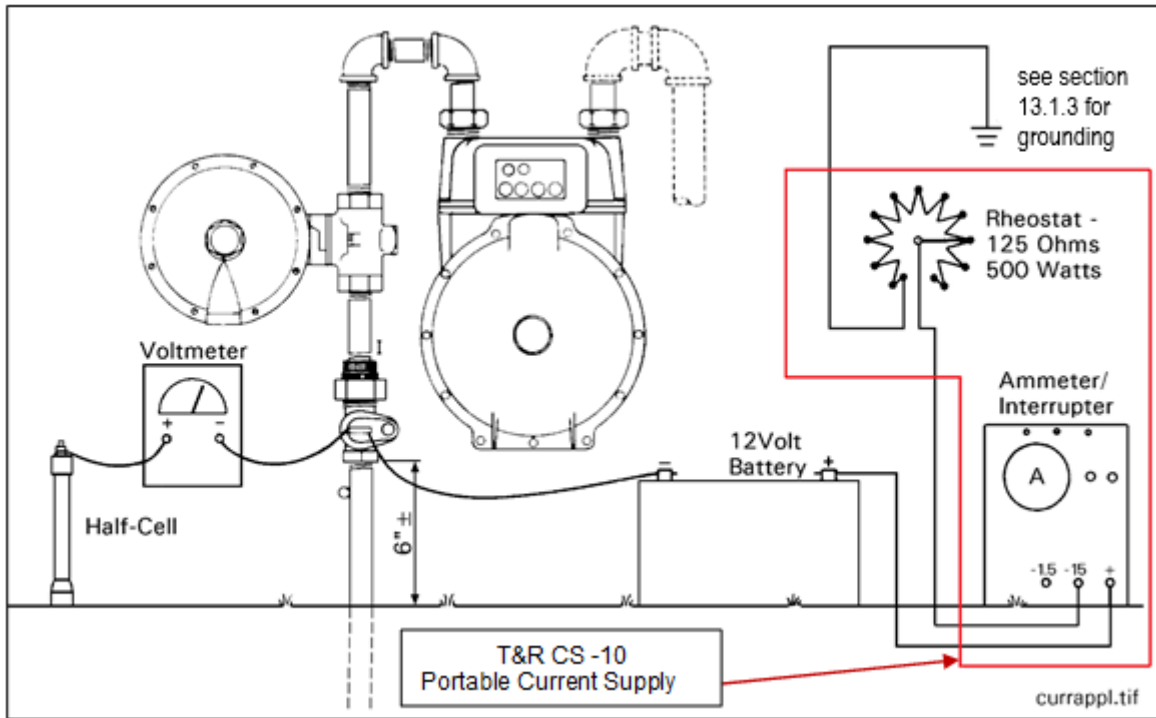

Figure 7 Schematic of Typical Current Application (See specific instructions for T&R CS 10 connections)

DO NOT apply current without using a rheostat.

13.1.2 Set interrupter cycle for X seconds on and Y seconds off. See [Figure 8](#).

Usually time on is longer than the time off.



Figure 8 Power Supply Interrupter Setting

13.1.3 The ground connection, shown in figure 7, may be a chain link fence, steel culvert, insulated down guy, galvanic anode, or driven (portable) ground.

13.1.4 #8 or heavier wire shall be used for current carrying test leads.

UNCONTROLLED IF PRINTED

Beware of "ground bed effect" when measuring potentials. (The soil potential near the current ground becomes more positive causing the pipeline to appear more negative than it actually is.)

13.1.5 After all the connections are made and voltmeter and half-cell are in place, reduce the circuit resistance with the rheostat.

13.1.6 Note potential and current rise.

1. When pipe-to-soil measurements reach -1.20 to -1.40 V, turn the interrupter on and take a pipe-to-soil measurement at least one block away in two directions noting voltage shift.

If the pipe-to-soil measurement was -1.15 V 'off' to -1.40 V 'on' at the point of application, voltage shift a block away may be approximately -1.15 V 'off' to -1.35 V 'on', provided there are no shorts and coating is good.

2. After these initial tests, leave the applied current on for a period of time to observe whether the pipe begins to polarize.

When the pipe polarizes, the pipe-to-soil measurements may increase and current requirement may drop.

3. If the pipe is shorted the pipe will not polarize.
4. If there are shorts, current required should be well above the maximum calculated current requirement.

The indicated current is a measure of how much current is to be added.

5. Divide the additional current requirement by the current output of one anode and determine the number of anodes to be added.

13.1.7 Anode outputs. See table 3.

Table 3 Anode current outputs

Soil Resistivity	17 Hi-Potential magnesium anode current output
Less than 9,000 ohm-cm	30 mA
9,000 to 15,000 ohm-cm	15 mA
over 15,000 ohm-cm	Contact Gas Technical Support

Typical Illinois soil will be less than 9,000 ohm-cm while sandy or rocky areas can be over 15,000 ohm-cm.

14.0 Current Interrupters

- 14.1 The ability to interrupt cathodic protection current is an important technique that is used in cathodic protection testing.
- 14.2 The current interrupter can be used individually or simultaneously with multiple synchronizable units to create an 'instant off' potential for the pipeline.
- 14.3 The interrupter is set to stop the flow of current momentarily and reconnect it at a pre-set interval. This allows a technician to verify that the potentials measured are on a particular structure and to minimize IR drop.
- 14.4 Current interrupters that can be synchronized are either quartz clock controlled or GPS controlled. See [Figure 9](#).

Most quartz clock interrupters drift about 1 second per 24 hours and will be out of sync after 48 hours.



Figure 9 GPS Controlled Current Interrupter

End of Instructions.

Operator Qualification (OQ) Required?

Yes.

- 0001: Measure Structure- to-Electrolyte Potential
- 0011: Conduct Close Interval Survey
- 0021: Measure Soil Resistivity
- 0031: Inspect and monitor Galvanic Ground Beds/Anodes
- 0041: Installation and Maintenance of Mechanical Electrical Connections
- 0051: Installation of Exothermic Electrical Connections

UNCONTROLLED IF PRINTED

0061: Inspect or Test Cathodic Protection Bonds

0071: Inspect or Test Cathodic Electrical Isolation Devices

0081: Install Cathodic Protection Electrical Isolation Devices

0091: Troubleshoot In- Service Cathodic Protection System

0101: Inspect Rectifier and Obtain Readings

0111: Maintain Rectifier

Appendices

NONE.

Attachments

NONE.

Compliance Requirements

NONE

Reference Documents

NONE

Document Rescission

CORR 2.5 Corrosion Control: CP System Troubleshooting, October 1, 2020

Revision Notes

Location of Changes	Summary of Changes
Subsection 14.2	Grammatical correction – "to create an instant off"

CORROSION CONTROL

October 1, 2020

CORR 2.6 AC Interference on Buried Pipelines and Stray Current

1.0 Purpose

The purpose of this document is to provide guidance in identifying and eliminating ac interference and stray current on buried pipelines.

2.0 Scope

This document addresses the following:

[3.0 Target Audience](#)

[4.0 General](#)

[5.0 Types of AC Interference](#)

[6.0 Investigating AC Voltages on Pipelines](#)

[7.0 Stray Current](#)

3.0 Target Audience

- Corrosion Control Supervisors
- Corrosion Control Specialists

4.0 General

4.1 AC Interference

- 4.1.1 When both gas and electric lines are in the same utility corridor there can be an induction of an AC voltage onto the pipeline or a short-term introduction of voltage and current caused by lightning or a ground fault.
- 4.1.2 Under certain conditions, the induced voltage can be a hazard to pipeline personnel and in the long term could lead to pipe corrosion if current densities are high.
- 4.1.3 Pipelines subject to significant induced AC voltages with high AC current densities must have a grounding system that will pass AC current to ground while maintaining the DC voltage of the cathodic protection system.
- 4.1.4 AC investigations should only be performed by or under the direction of a person trained and experienced in cathodic protection and the implications of AC voltage on pipeline facilities.

4.2 Stray Current

- 4.2.1 Stray current is any current induced on a pipeline from a foreign source. This may be caused at a pipeline crossing, near gas stations, tank farms or refineries with rectifiers or close to DC transit systems.
1. Whenever direct current is used in industrial or commercial processes, the current must flow from the generator to the process and back to the generator to complete the circuit and permit the current flow.
 2. If there is a pipeline near the return path of the current it is possible that it will serve as an additional path for the return of the current to the generator.

UNCONTROLLED IF PRINTED

3. No damage is done to the pipe where the current enters it, but at the point where the current leaves the pipe to return to the generator, that area is anodic and the pipe will corrode.
 - 3 a. Such areas are called "hot spots" or "positive areas" and current causing such corrosion is called 'stray current'.
 - 3 b. This current can be hundreds and thousands of times as great as current from local corrosion cells and corrosion can be very severe.
- 4.2.2 Stray current from foreign pipelines operating near our gas lines is the most common source of stray current.
- 4.2.3 Testing for stray DC current interference from CP systems is reasonably straight forward.
 1. An operator of the foreign pipeline should always be contacted prior to performing any tests to ensure no damage is done to their system.
 2. An automatic current interrupter may be installed in the output of the rectifier.
 3. The interrupter will cycle the unit on and off to show what affect the foreign pipeline has on our pipeline. See Figure 1 for typical current interrupted.



Figure 1 GPS Controlled Current Interrupter

4. Potential measurements should be taken at each pipeline crossing.

5.0 Types of AC Interference

5.1 Electrostatic or Capacitive Interference

- 5.1.1 This type of interference occurs in the immediate vicinity of the overhead power lines. The pipeline picks up a voltage relative to the soil, which is proportional to the voltage in the transmission line. This is usually observed during construction of the pipeline when the pipe is on skids prior to burial.

5.2 Resistive or Ohmic Interference

- 5.2.1 This occurs when lightning strikes an electric transmission structure, when the load at a 3-phase transformer bank is unbalanced, when a neutral is lost, or when there is a phase to ground fault. If a pipeline is located within this area, the AC potential of the pipeline can rise.

5.3 Electromagnetic or Inductive Interference

- 5.3.1 This occurs when there is extended and close parallel routing with three-phase high voltage AC transmission lines.
 1. The induced voltage is due to any phase imbalance in the lines.

UNCONTROLLED IF PRINTED

2. The likelihood of interference increases with rising operating currents in the overhead lines, with increasing quality of the coating on the pipeline, and with the length of line parallel to and close to the high voltage AC (HVAC) transmission lines.
 3. Voltage is induced in the pipeline by magnetic coupling with the high-voltage lines, and results in current flowing in the pipeline. This current results in a voltage difference between the pipeline and the surrounding soil.
 4. Voltages tend to be the highest where the pipeline enters and leaves the electric transmission right of way (ROW).
- 5.3.2 When a long-term induced AC voltage exists on the pipeline resulting from long sections of the two lines in parallel, it may not be safe to touch the pipeline or appurtenances.
1. This "contact" voltage, or the difference between the line and the earth, can cause AC current to flow to ground through a person touching the line.

When a metal structure, such as a pipeline, is under the influence of electrical fields and a person touches it, current can pass through their body to the earth because the person becomes the shortest path to ground.

2. The amount of that current depends upon the electrical resistance through their body and resistance to earth.

6.0 Investigating AC Voltages on Pipelines

6.1 Although each situation will be unique, general pre-planning should include the following:

6.1.1 Notifications

1. Depending on the situation, notification may be needed to the following:
 - 1 a. The local land owner.
 - 1 b. The local gas operations supervision.
 - 1 c. The local electric operations supervision (if the investigative work will involve the electric facilities).
 - 1 d. Other pipeline facility owners (if their facilities will be involved).
 - 1 e. Other gas crews working in the same area.

6.1.2 Safety Precautions

1. Use proper gloving (voltages over 50 volts AC).
2. Use AC sensing device. See [Figure 2](#) for typical device.
3. Use required PPE.

Treat every line as though it were electrically charged until proven otherwise and wear the protective gear!

UNCONTROLLED IF PRINTED



Figure 2 AC voltage sensor

6.2 Gathering Information

6.2.1 Information gathering is the most important step in investigating an AC problem. The desired information for the investigation can be summarized as follows:

1. The physical locations of pipeline and transmission line routes are needed as well as accurate distances.
2. Top view scale drawing or map of the entire geographical area of interest, showing all conductors (pipelines) under study in sufficient details, along with major installations which could provide grounding.
3. Electric transmission line and pipeline details:
 - 3 a. Diameters of all pipelines that are in the vicinity or crossing the electric transmission line ROW.
 - 3 b. Pipelines running parallel to the existing or proposed transmission lines.
 - 3 c. Pipeline coating quality.
 - 3 d. The resistivity of the earth along the pipeline.
 - 3 e. Depth of pipelines.
 - 3 f. Transmission line tower configuration, height, and horizontal separation between all parallel conductors.
 - 3 g. Distance of the pipeline from the center of the electric line path.
 - 3 h. Electric transmission voltages and current flows.

6.3 Select the proper tools

6.3.1 The selection of the proper tool depends on the situation needed. Various tools used throughout the industry (not an all-inclusive list):

1. Multi-meter - used to take DC and AC voltage readings off of target pipe.
2. Data logger - used to log variances in voltage or current flow from target pipe. (Ameren typically uses a Elecsys Watchdog set in data logger mode.)
3. Portable AC non-contact ammeter. See Figure 3.

UNCONTROLLED IF PRINTED

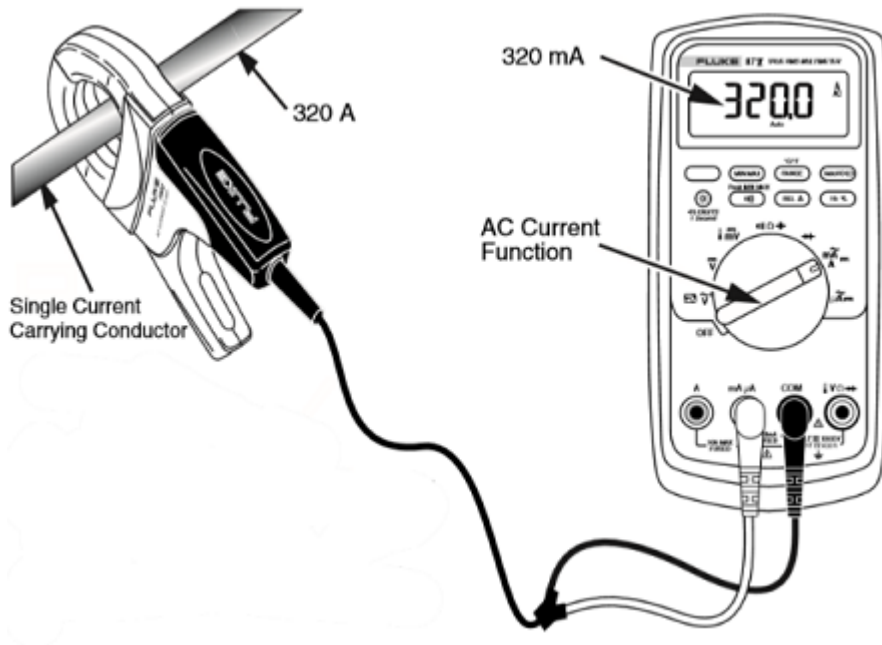

Figure 3 Typical non-contact ammeter.

4. Soil resistivity tool. See Figure 4.



Figure 4 Soil resistivity instrument

6.4 Conduct the Investigation

6.4.1 A thorough information gathering process will usually reveal the necessary clues to effectively narrow down the possible causes of the source of an AC problem.

1. For example, starting at the target pipe entrance and exit perform a few simple measurements using one or more of the above-mentioned tools.
2. This can help determine the probable cause of the problem and determine the primary type of interference involved.
3. Assumptions made when conducting an evaluation should be made based on the information gathered previously.

6.4.2 It is also important that information, such as the bonding of the transmission pipeline to distribution systems, location of insulating flanges and the proximity of neutrals and wiring grounds are documented.

6.5 Analyze the Data and Locate the Source

6.5.1 After completing the investigation, assemble the data and look for patterns.

6.5.2 Even if the source is determined during an investigation, taking some time to review the data to learn more about the problem will lead to possible solutions.

UNCONTROLLED IF PRINTED

6.6 Select a Solution

6.6.1 Consider the following:

1. Facility's operations
2. Electromagnetic environment
3. Operation of the affected equipment

6.6.2 Evaluate the

1. Safety
2. Cost
3. Installation
4. Maintenance
5. Aesthetics
6. Performance record of each possible solution

6.6.3 Review the chosen solution with involved individuals before procurement of materials and installation to ensure that any effects on facility operations and equipment performance are known and kept to a minimum.

6.6.4 The most common solutions to AC problems include:

1. Shields
2. Filters
3. Anodes
4. Enhanced grounding techniques.

6.6.5 Possible solutions to protect the pipeline include:

1. Galvanic Anodes
 - 1 a. The use of galvanic anodes is a cost effective and practical means to address AC interference on a target line.
 - 1 b. Install banks of anodes where voltages are highest to safely ground the pipeline.
2. Solid State Decouplers (SSD)
 - 2 a. The SSD is a solid-state device designed to simultaneously provide DC decoupling and AC continuity/grounding when used with cathodically protected structures, such as pipelines, tanks and grounding systems. See [Figure 5](#).
 - (i) Use a MTF to attach the SSD to the flange. See [Figure 6](#).



Figure 5 Decoupling Device (Stock Code 40 89 716)

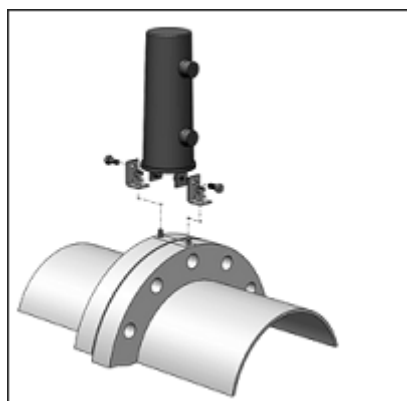

Figure 6 MTF SSD Mounting Kit.

- 2 b. The SSD is used for:
 - (i) insulated joint protection
 - (ii) AC mitigation
 - (iii) DC isolation/AC grounding of electrical equipment on pipelines and tanks.
3. Bare Copper Cables for AC mitigation.
 - 3 a. Advances in interference control have resulted in the gradient control wire method.
 - 3 b. This method consists of one or more bare copper cables buried parallel to and near the pipeline and regularly connected to it through decoupling device(s).

UNCONTROLLED IF PRINTED

- 3 c. Gradient control wires used in this way is very effective in mitigating excessive pipeline potentials due to both inductive and conductive interference.
- 3 d. For inductive interference, gradient control wires provide additional grounding for the pipeline and decrease the induced pipe potential rise. At the same time, they raise local ground potentials, thus sharply reducing touch potentials and coating stress voltages.
- 3 e. For conductive interference, gradient control wires dampen the soil potential rise close to the pipe while raising pipe potentials, thus providing reduced touch voltages and decreasing coating stress voltages. See Figure 7.

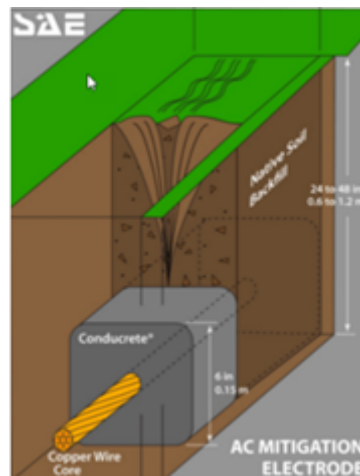

Figure 7 Copper Cables Used for AC mitigation

- 3 f. Bare copper cables can be used when overhead high voltage transmission lines share a corridor with an underground pipeline.
- 3 g. Bare copper cables, buried parallel to a pipeline and regularly connected to it through decoupling device(s), are effective in mitigating pipeline potentials due to inductive and conductive interference.

6.7 Verify Solution Performance

- 6.7.1 Follow up verification shall take place after the solution has been implemented and facility operations have returned to normal.
- 6.7.2 Watch the performance of the installed solution and repeat emissions measurements at the affected equipment. Document procedures, equipment installation, and performance results as required.

- 1. All information found in these guidelines should only be considered as guiding principles as to what could be done when power lines interact with metallic buried pipelines.
- 2. It is assumed that individuals performing such test have received proper cathodic protection training.

7.0 Stray Current

UNCONTROLLED IF PRINTED

7.1 When to test

- 7.1.1 Perform testing when a low potential is observed at a pipeline crossing, near gas stations, tank farms, or refineries with rectifiers, DC transit systems, coal mines, or when rectifier installations are discovered near AIC facilities. Low or high potentials can indicate the presence of stray current

7.2 Tests to Perform

- 7.2.1 Take potentials along the Ameren pipeline at 5 feet or 10 feet intervals (close interval survey) from the crossing in both directions and document the measurements. If the lowest potential is at the crossing and other potentials increase as the distance from the crossing increases, stray current is suspected.
- 7.2.2 Call the foreign operator and arrange to interrupt the nearby rectifiers.
- 7.2.3 When interrupting foreign rectifiers, note the AIC potential at the crossing. If the potential returns to normal during the "off" cycle, interference is verified.
- 7.2.4 A permanent bond can be installed to restore the AIC 'on' potential to the level noted during the 'off' cycle of the foreign rectifier.
 1. The bond connects the AIC system and the foreign system together allowing the current picked up by Ameren to return through the bond wires.
 2. The foreign company may want to limit the current draw from their system by installing resistance in the bond. This installation becomes a critical bond and must be monitored every 2 months not to exceed 2 ½ months.
- 7.2.5 Other corrective measures may include installing galvanic anodes or reducing output of the interfering rectifier.

7.3 Other Situations Involving Rectifiers

- 7.3.1 Survey the affected area to find the pickup and discharge points.
- 7.3.2 Call the foreign operator and arrange to interrupt the nearby rectifiers.
- 7.3.3 When interrupting foreign rectifiers, note the AIC potential at the location of the lowest potential. If the potential returns to normal during the 'off' cycle, interference is verified.
- 7.3.4 If a bond is installed, return the AIC 'on' potential to the level noted during the 'off' cycle of the foreign rectifier.
- 7.3.5 Other corrective measures may include installing galvanic anodes or reducing output of the interfering rectifier.

7.4 Transit Systems, Coal Mines, Telluric Currents

- 7.4.1 Perform 24-hour data recording at sites with suspected interference.
- 7.4.2 Solutions depend upon the situation and may include:
 1. Auto potential rectifiers
 2. Current shields
 3. Bonds
 4. Galvanic anode beds

End of Instructions.

UNCONTROLLED IF PRINTED

Operator Qualification (OQ) Required?

YES

- 0001: Measure Structure- to-Electrolyte Potential
- 0011: Conduct Close Interval Survey
- 0021: Measure Soil Resistivity
- 0031: Inspect and monitor Galvanic Ground Beds/Anodes
- 0041: Installation and Maintenance of Mechanical Electrical Connections
- 0051: Installation of Exothermic Electrical Connections
- 0061: Inspect or Test Cathodic Protection Bonds
- 0071: Inspect or Test Cathodic Electrical Isolation Devices
- 0081: Install Cathodic Protection Electrical Isolation Devices
- 0091: Troubleshoot In- Service Cathodic Protection System
- 0101: Inspect Rectifier and Obtain Readings
- 0111: Maintain Rectifier

Appendices

NONE.

Attachments

NONE.

Compliance Requirements

NONE.

Reference Documents

NONE.

Document Rescission

CORR 2.24 Corrosion Control: Stray Current, April 1, 2012.

CORR 2.25 Corrosion Control: AC Interference on Buried Pipelines, April 1, 2019.

Revision Notes

Location of Changes	Summary of Changes
Not applicable.	This is a new document.

UNCONTROLLED IF PRINTED

CORROSION CONTROL

October 1, 2022

CORR 2.7 Short Investigation and Clearing Shorted Pipelines

1.0 Purpose

The purpose of this procedure to provide guidance in investigating, locating, and eliminating electrical shorts which cause low cathodic potentials on structures.

2.0 Scope

This document addresses the following:

[3.0 Target Audience](#)[4.0 General](#)[5.0 Localizing the Shorted Area](#)[6.0 Null Method](#)[7.0 Peak Method](#)[8.0 Parallel Mains](#)[9.0 Shorting Locating Tips](#)[10.0 Casings](#)[11.0 Isolated Services](#)[12.0 Clearing Shorted Pipelines](#)

Appendices:

[Appendix A - Short Detection Diagrams](#)[Appendix B - Cased Crossing Monitoring](#)[Appendix C - Equipment](#)

3.0 Target Audience

- Corrosion Control Supervisors
- Corrosion Control Specialists

4.0 General

4.1 A common cause of low potentials on cathodically protected gas distribution systems is a "short".

4.1.1 A short is an undesirable contact or connection to an unprotected structure.

4.1.2 Contacts or shorts overburden the protection system, causing increased current output and lower potentials.

4.1.3 Change in resistance results in most protective current being diverted to the unprotected structure, causing the intended structure to be inadequately protected.

4.2 Shorts are frequently caused by one or more of the following:

4.2.1 Direct contact with services and/or mains at underground crossings with an unprotected structure.

UNCONTROLLED IF PRINTED

4.2.2 Regulator vent lines contacting:

1. Aluminum siding
2. Termite shields
3. Inside piping
4. Furnace ducts
5. Electric conduit on inside meter sets

4.2.3 Shorted flange installations on large meter sets through bolts, gaskets, control lines and bypass lines.

4.2.4 Shorted or omitted insulators at service risers.

4.2.5 Shorted flange installations below grade between structures and unprotected mains or services.

4.2.6 Foreign utility's grounding to Ameren Illinois' gas facilities.

4.3 Reasons for low potentials other than shorts include:

4.3.1 Additional pipe being added without additional protection.

4.3.2 Anode depletion or loss of anode connection(s).

4.3.3 Rectifier malfunctions.

4.3.4 Interference current discharge area.

4.3.5 Anode output down due to unusually dry conditions.

4.3.6 High resistance soil.

4.3.7 High resistance in the measuring circuit caused by the half-cell, or dry soil.

4.3.8 Deteriorated or damaged coating.

4.4 Personnel should be able to determine whether shorts are present by taking sample readings throughout a system.

4.4.1 Drastic drops do not usually occur at or near a particular test point on a shorted galvanic anode structure.

4.4.2 Checking the history of a particular structure on a galvanic anode system will also help determine whether a shorted condition exists.

1. For instance, if a structure was reading in the -1,200 mV range last year and the annual survey indicates readings from the -600 through -850 mV range this year, experience will show that on a galvanic anode system, a shorted condition exists unless bond wires to another source of current has been broken.

4.4.3 On a rectified system, pipe-to-soil measurements may drop more drastically at or near a foreign contact or stray current situation but may recover to some extent past the problem area.

5.0 Localizing the Shorted Area

5.1 Applied Current

5.1.1 Applied current can be used to locate the vicinity of the short by taking pipe-to-soil measurements throughout the system while interrupted current is applied.

1. Areas near the short should show low shift between 'on' and 'off'.
2. The difference between "on" and "off" potentials is called delta voltage.
3. For example, if the 'off' reading is -1.15 V and the 'on' reading is -1.40 V, delta V is 0.25 V. Delta V will decrease near a short. Current attenuation also causes a gradual decrease in delta V as the distance from the current source increases.

5.2 Open Bonds

5.2.1 Another method to localize the shorted area is to open any bond on the structure and take a pipe-to-soil measurement on each side of the insulator.

1. If the pipe-to-soil measurement on one side is higher and the other side is lower than the initial structure pipe-to-soil measurement, the short is probably located on the structure with the lower pipe-to-soil measurement.

5.3 Check Insulation Integrity

5.3.1 Applied interrupted current can also be used to check insulation integrity between structures.

1. If the insulation is good, there should be good voltage shift on the current applied side, and little or no shift on the opposite side.
2. With poor insulation, the voltage shift will be noted on both sides of the insulation.

5.4 Equipment

5.4.1 Several instruments can be used to locate contacts between protected and unprotected facilities. See [Appendix C](#).

Do not use a pipe and cable locator which has an "inductive" mode of operation.

Best results are obtained with outputs in the audio range below 800 cycles per second (CPS).

5.4.2 The basic short locator consists of the following:

1. Transmitter (See [Appendix C-2](#))
 - 1 a. The transmitter must have direct connection to the pipe and a good ground to function.
 - 1 b. In order for maximum signal to be applied the transmitter settings are used to match load (structure) impedance.
2. Receiver (See [Appendix C-2](#))
 - 2 a. The receiver is equipped with search coil, resonate filters, amplifier with speaker, output jack for head set, and a gain control.
3. Head phones (optional)

5.5 Tracing with the Locator

UNCONTROLLED IF PRINTED

5.5.1 The operating principle of the short locator is based on the signal, an audio electric current, seeking the least resistant path to ground.

1. The signal strength is dependent on the amount of bare metal allowing the current to return to ground.
2. Some signal may be lost through coating holidays and at anodes, but generally it is not enough to interfere with short location.
3. Normally, the signal should leave coated pipe at a short.

5.6 Instrument Connection

5.6.1 Proper instrument connection is essential to good short location, instrument performance, and instrument care.

5.6.2 Take the following precautions for both safety and instrument care:

1. Be sure of polarity when making connections to an external battery.

Improper polarity will damage the transmitter.

The output leads may cause shock if the transmitter is on and both leads are held by the operator, or if one lead is held and the operator is well grounded.

The pipe and/or ground leads can produce arcing if connected or disconnected with the transmitter on.

2. Always ensure the transmitter is off when connecting or disconnecting the leads.
3. Selection of a ground is important.
 - 3 a. Do not use water systems or anything connected to the AC ground system.
 - 3 b. Use:

Use caution when making connections in enclosed areas such as regulator pits and meter houses.

- (i) Chain link fences
- (ii) Steel culverts
- (iii) Steel basement window wells
- (iv) Galvanic anode banks,

UNCONTROLLED IF PRINTED

- (v) Utility pole down guys that are insulated from the AC ground system
- (vi) Other cathodic protection structure for grounds.

5.7 Adjusting the Instrument

- 5.7.1 After connections are made, turn the transmitter on and adjust output. Low output can be caused by:
1. Poor ground
 2. Poor connections at pipe or ground
 3. Weak battery
 4. Small isolated structure

If the gain is turned too high on the receiver, it may be impossible to note when a null occurs, particularly on small diameter pipe.

- 5.7.2 With the transmitter properly adjusted and receiver tuned to receive a signal level of from 60% to 80%, trace the line by denoting the null. See [Section 6.0](#) and [Appendix A-1.1](#).

6.0 Null Method

- 6.1 Trace the pipe by nulling out with the receiver.
- 6.1.1 The null should occur when the receiver is directly above the pipe, and no signal is heard. See [Appendix A-1.1](#).
- 6.1.2 Often a null over a bare line can be distinguished from a null over a coated line.
- 6.1.3 Generally, signal over a coated line is sharp and distinct; whereas, signal over a bare line is flat and mushy with signal strength rapidly diminishing.
- 6.2 At a tee, such as the service tee shown in [Appendix A-1.1](#), signal should drop abruptly beyond it.
- 6.2.1 From the point of signal loss, go back 4 feet or 5 feet and begin a 360° trace around the point, noting where nulls occur.
- 6.2.2 The best or sharpest nulls should be noticed over the connected service, and over the piece of main toward the short. See [Appendix A-1.1](#).
- 6.2.3 If the system is a closed loop, signal can travel in each direction with equal intensity.
- 6.3 After determining which direction the signal is traveling, walk the main until reaching a point or area of signal disturbance. If there is a water line, or another bare structure between the line traced and the receiver, signal reception will be poor.
- 6.4 As the main is being traced, cross it periodically, noting if the null location is where it should be relative to the gas main location.
- 6.4.1 When a gas and water line are on the same side of the street and relatively close, it is possible to go past a point of signal transfer at a short.
- 6.4.2 The closer the mains lie, the more difficult it is to locate the short.

- 6.5 From the point of signal disturbance, go back until a clear signal is again received. Make a 360° trace around the point, and note where nulls occur. The figure in [Appendix A-1.2](#) shows a water service shorted to the gas main. The signal may go either toward the building and/or toward the water main via the water service.

Signal will not always cross over to the water main. Many times, it will go toward the house, and sometimes in both directions.

- 6.6 After determining where the contact is, move the transmitter to the other side of the short.
- 6.6.1 If the conclusions are the same after tracing back from the opposite direction, the short has been proven.
- 6.6.2 Dig up the short and make necessary corrections.
- 6.7 Do not assume a water service is shorted because it can be traced with the short locator.
- 6.7.1 It is possible to have an excellent signal on the water service, with no underground contact.
- 6.7.2 In such cases, the actual short may be at the meter installation.
- 6.7.3 Note, in the figure in [Appendix A-1.3](#), that the signal goes through the shorted meter set, through the hot water heater, and into the water system.
- 6.7.4 Gas services are usually not detectable unless shorted.
- 6.7.5 A service at or near the end of a main can be detected if there is an anode on the riser.
- 6.7.6 Signal on the service is lost as soon as the anode is disconnected.

Notice that in this case the water service can be picked up before the gas, showing the necessity of determining whether signal goes beyond the water service.

- 6.8 There are several ways a gas service can be shorted other than through or bypassing insulation. To verify the short is at the insulation, trace the signal up to and through the meter. If the signal cannot be traced, the service may be shorted due to the following:
- 6.8.1 Underground contact to water service.
- 6.8.2 Underground contact to water main or another bare structure.
- 6.8.3 Underground contact to television antenna tower footing.
- 6.8.4 Underground contact to building electric ground.

7.0 Peak Method

- 7.1 In the peak method, the transmitter is set up in the same way as the null method.
- 7.1.1 Position the receiver with the antenna upright and parallel to the pipe or set the receiver to peak mode.

- 7.1.2 The loudest signal should be heard when the receiver is directly over the pipe.
- 7.2 Walk the main 50 feet to 100 feet. in each direction from the transmitter connection to determine the signal strength (loudest tone). See [Appendix A-2.1](#).
- 7.3 Walk the main in the direction of the strongest signal.
 - 7.3.1 The signal will drop when the receiver is taken past the short.
 - 7.3.2 When the tone drops sharply, circle the area to find new direction on the signal.
- 7.4 In figure in [Appendix A-2.2](#), the signal peaks sharply until the point of contact is passed indicating a possible contact.
 - 7.4.1 The null method may be used to pinpoint the point of contact.
 - 7.4.2 In this case the signal may go to the water main or the house.
- 7.5 In [Appendix A-2.3](#), the gas service is traced to the house, which usually indicates a failed insulator at the meter set.

Signal will not always cross over to the water main. Many times, it will go toward the house, and sometimes in both directions.

In [Appendix A-2.3](#) the water service can be picked up before the gas, showing the necessity of determining whether signal goes beyond the water.

8.0 Parallel Mains

- 8.1 In this context, parallel mains are on the same side of a street, separated by a few inches to a few feet.
- 8.2 The closer the two pipelines are, the more difficult it is to locate a short between them.
 - 8.2.1 The best way to locate such shorts is to find the general area of the short by using interrupted supplied current then set up the short locator in the area and move across the pipeline.
 - 8.2.2 Nulling should be done carefully.
 - 8.2.3 Hold the receiver level during lateral movement to ensure precise location.
- 8.3 When trying to locate shorts between parallel mains, a null may be detected at the contact point.
 - 8.3.1 There may only be a change in the tone of the receiver or a difference in the null over the line.
 - 8.3.2 The positive indication to look for is an offset in the line by carefully tracing and marking the location.
 - 8.3.3 The line may be 6 inches or more to the left or right.
 - 8.3.4 When an offset is found, hold the receiver so that the coil is between the traced lines.

8.3.5 Move across the pipeline between them until a null is found at the cross-over; this is where to dig.

8.4 As a final check, set up the transmitter using the foreign structure suspected to be in contact with the pipe for the ground.

8.4.1 The signal should go out and come back to the transmitter.

8.4.2 Dig 1 to 2 feet beyond where the signal changes direction.

9.0 Shorting Locating Tips

9.1 If the locator is near a short, it is possible to push a signal through it. Moving the transmitter farther away may make a difference.

9.2 At 90° elbows, a null may be detected along an imaginary line bisecting the elbow. The signal strength determines how far the null can be traced.

9.3 At crosses, a signal can cancel itself out and may not be detected in any direction. In such cases, it may be necessary to move beyond the cross a few feet to again detect signal, or change the location of the transmitter.

9.4 In large, complex systems, it may be necessary to make several set ups throughout the system before a short is found.

9.5 Rarely more than one short at a time can be found in a specific system. It is best to clear the first short, recheck, and search for others.

9.6 If possible, always verify a short from 2 directions.

10.0 Casings

10.1 Refer to [Figure 1](#) for the most common casing to carrier pipe shorts.

10.2 Refer to [Appendix B](#) for typical casing installation and monitoring

10.3 If a casing is full of water and does not have a metal to metal short, the pipeline's CP system passes current through the casing wall and through the water to provide cathodic protection.

When a casing has a metal to metal short, the casing shields the pipeline inside from the protective CP current leaving the pipe inside the casing unprotected.

10.4 Testing

10.4.1 The most common method of testing casings is by comparing the pipe to soil potential of the carrier pipe and the casing-to-soil potential of the casing pipe in the same soil taken with the half cell at the same spot.

1. Perform additional tests if the difference in the potentials is less than 25 mV (0.025 V).

10.4.2 If a pipe-to-soil measurement remote to the casing is used for the comparison, perform additional tests if the difference in the potentials is less than 200 mV (0.200 V).

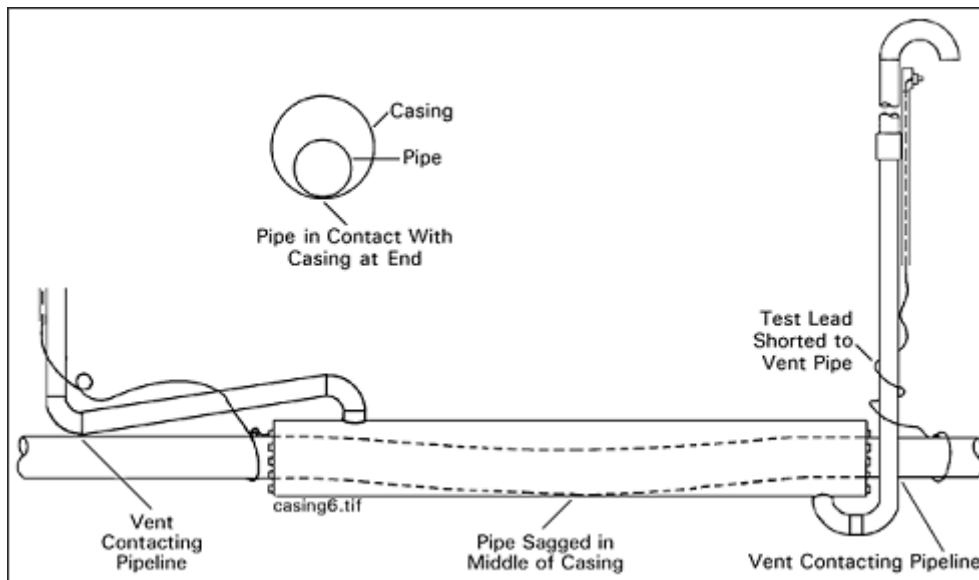

Figure 1 Common Shorts Found on Casings

10.5 Casing Short Tests

10.5.1 To verify whether a casing that fails the P/S and C/S potential comparison is actually shorted. Use the Reverse Current Method.

1. This method can be used to readily check the presence of an electrical short.
 - 1 a. The carrier pipe-to-casing potential is measured while increasing the reverse current to the casing.

Reverse current is accomplished by applying current to the carrier pipe while using the casing for ground.

- 1 b. If there is electrical isolation, the casing potential can be driven more positive while the carrier pipe becomes more negative.
- 1 c. Measuring the potential between the carrier pipe and casing will reflect an increase in the potential difference as current flow is increased.
- 1 d. If a low resistance short is present, increased current will not change the potential difference.
- 1 e. Casing condition can also be checked by observing the pipe-to soil potential of the carrier pipe to the pipe-to-soil potential of the casing as current is applied and increased.
- 1 f. If the casing is clear, the carrier pipe will become more negative and the casing will become more positive.
- 1 g. If there is a short, the potentials will either stay the same or both go the same direction.

10.5.2 Location of Short

1. Once a short has been determined, it may be possible to determine the approximate location of the contact with a T&R locator. See [Appendix C-2](#).

UNCONTROLLED IF PRINTED

- 1 a. Clip the transmitter's pipe lead to the test lead and the transmitter's ground lead to a reel of test wire and clip to the casing vent.
- 1 b. With the transmitter output set to 2.5, turn the transmitter on and trace signal around the casing with the receiver.
 - (i) If the signal goes to the opposite end and then quickly fades, the short may be at that end.
 - (ii) If no signal can be traced except at the end with the equipment hook up, that may be the location of the short.
 - (iii) These two situations can be checked by moving the equipment to the opposite end and checking to see whether the signal fades at about the same place.
 - (iv) On casings with only one test lead, it is NOT possible to perform the previous test.
 - (v) Use of the T&R locator in this manner does not guarantee the exact short location. It is intended to provide a means of determining which end should be excavated first.
 - (vi) If the signal fades in the middle, excavate each end and inspect for contact.

10.5.3 Clearing a Shorted Casing

1. Use the following alternatives to clear a shorted casing:
 - 1 a. If possible, remove the casing.
 - 1 b. Abandon casing and reroute with approved piping.
 - 1 c. Excavate the casing ends
 - (i) Clear shorts between casing vents and carrier pipe.
 - (ii) Remove the test leads shorted to casing.
 - (iii) Install vents as necessary.
 - (iv) Install new end seals only after the carrier pipe is centered.
 - (v) If end seals will not fit, install FRP insulators and seal the end of the casing with wax tape.
 - (vi) Install test leads as necessary.
 - (vii) As a last resort, fill casing with dielectric casing filler.

11.0 Isolated Services

- 11.1 If the cathodic protection level is unsatisfactory (less than -0.85 V pipe-to-soil) on isolated services, a current requirement test can be performed to determine whether an additional anode will correct the protection level.

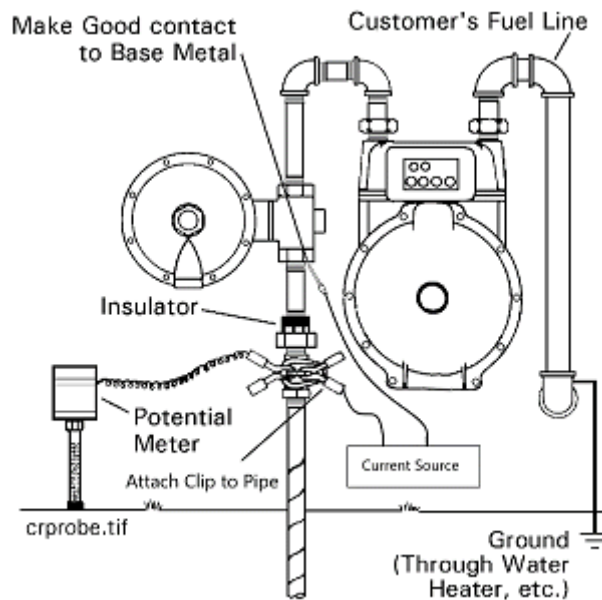

Figure 2

If Customer's Fuel Line Is grounded

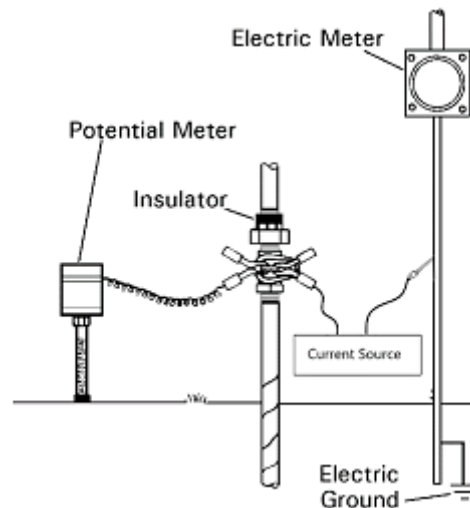

Figure 3

If Customer's Fuel Line Is Not Grounded

11.2 Instructions

- 11.2.1 Attach clip to fuel line side of insulated meter valve to check house piping with potential meter. If any reading is indicated, the house piping is probably sufficiently grounded.
- 11.2.2 Attach potential meter clip to gas service side of meter valve insulator.
- 11.2.3 Attach negative current source clip to gas service side of meter valve.
- 11.2.4 Turn on batteries to current source (see [Appendix C-5](#)) and touch house piping on opposite side of the insulator with positive side of the current source, while reading pipe-to-soil potential.

UNCONTROLLED IF PRINTED

- 11.2.5 If protection level increases to satisfactory level (typically 1.6V or greater) an anode may be installed to reestablish cathodic protection.
- 11.2.6 If protection level does not increase, repeat with current source in contact with an electric ground.
- 11.2.7 If protection level still does not increase, investigate for a bad insulator or underground short. (The addition of an anode will NOT raise protection level if shorted.)
- 11.2.8 Verify if a service is actually isolated or part of a deficient structure.
- 11.2.9 Limited tests can be run at any test lead provided a good ground is available. Current spread will approximate that of an anode. Little or no raise in protection level should occur if the structure is shorted.

A current source may be created using a 1.5 V battery in series with a 1000 ohm resistor to test risers and a 1.5 V battery with a 100 ohm resistor may be used for isolated steel services. Connect the negative lead to the pipe and the positive lead to a ground. A Tinkor & Razor CS-1 may also be used ([Appendix C-5](#)).

12.0 Clearing Shorted Pipelines

- 12.1 Electrical shorts occur when a foreign metallic structure and a steel pipeline are in contact with each other. Pre-shaped insulators, such as fiberglass-reinforced plastic (FRP) insulators or FRP insulator squares, I-Rods, or NuBolts can be used to prevent or separate and electrically isolate mains and service lines from other unprotected structures.

Do not use items such as wood, rubber tires, or split PE pipe to insulate pipelines from other metallic structures.

- 12.2 For above grade applications, I-Rod spacers, [Subsection 12.6](#), or Nu-Bolt, [Subsection 12.7](#), should be used as the preferred method of pipe support insulation. However if I-Rod spacers or Nu-Bolts will not work for the application, then FRP spacers may be used instead.

I-Rod spacers, Nu-Bolt and FRP spacers are also used to prevent or minimize atmospheric corrosion on pipe installed on pipe supports. [CORR 1 Paragraph 15.3.4](#)

12.3 Insulator Squares

- 12.3.1 Insulator squares are FRP sheets which can be used for miscellaneous short clearing applications. See Figure 4.

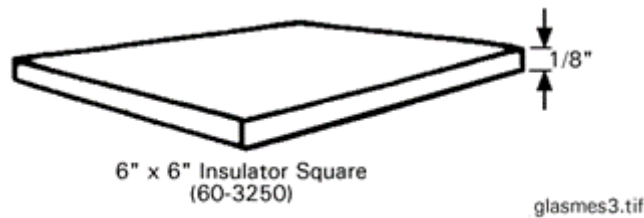

Figure 4: 6 inch x 6 inch Insulator Square (Stock Number 25 59 128)

12.4 Preformed FRP Spacers - Type 120 - Stocked

12.4.1 For preventing or correcting electrical shorts, caused by contact between steel pipes, use Type 120 FRP Spacers (refer to [Figure 5](#)). Spacers are 12" in length. See stock codes in [Table 1](#) for pipe sizes 2 inch to 12 inch. For sizes over 12 inch contact Gas Operations Support for purchasing assistance.

12.4.2 Installation:

1. Install insulator by placing on the pipe such that contact with the foreign line is eliminated. The insulator should be taped in place to prevent shifting during backfilling of the excavation. See [Figure 5](#).
2. If an FRP insulator is installed on a pipe support for above grade piping operating at over 60 psig and larger than 4 inch diameter, install the FRP insulator between pipe support(s) and the pipe as follows:
 - 2 a. The FRP should be cut to the approximate width of the saddle.
 - 2 b. Coat the FRP with Protal, see [CORR 2.3](#), ensuring 100% coverage prior to being adhered to the pipe.
 - 2 c. Adhere and press the FRP spacer against the pipe.
 - 2 d. Wipe off excess Protal and smooth out around the edges of the FRP to create a clean transition.
 - 2 e. Install pipe support under the FRP before the Protal cures.
 - 2 f. The FRP may be coated or painted with any approved method in [CORR 2.3](#).

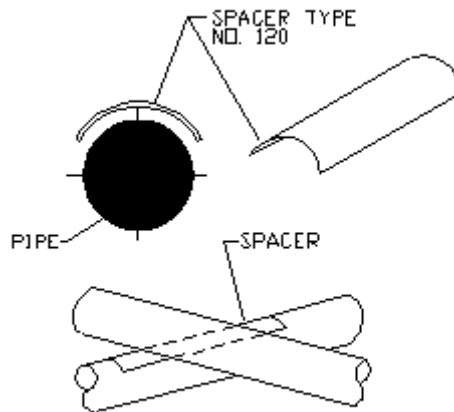

Figure 5 Spacer Installation

FRP Type 120 Pipe Size (inch)	Stock No.
2	49 62 008
3	49 62 009
4	49 62 010
6	49 62 011
8	49 62 012
10	49 62 013
12	49 62 014

Table 1 Type 120 FRP Spacers

12.5 FRP Insulators - Non-stock

12.5.1 These other types of FRP insulators for specific applications are available. Contact Gas Operations Support for purchasing assistance. Refer to Table 2.

Table 2 FRP Insulator Specific Application

	Type FRP Insulator	Application
	FPR Roll-on Shields Type 240	At hanger and support of overhead and pylon-supported pipes (Non-stock coded)

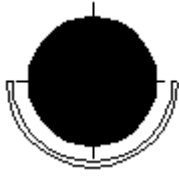
	<p>FRP Casing Insulators Type 220 & 240</p>	<p>Casing Insulator (Non-stock coded)</p>
	<p>FRP Pipe Saddles Type 180</p>	<p>Overhead hangers and supports (Non-stock coded)</p>

12.6 I-Rod Clips

12.6.1 I-Rod Clips are half cylinder spacers, designed to fit over the surface of a pipe support. They are designed to stick on new or existing cradle and clamp style pipe supports.

1. An adhesive strip on the bottom side, along with the weight of the pipe, holds the clip in place on the support. This effectively eliminates contact between the two metallic surfaces of the pipe and support.



Figure 6: I-Rod Clip

12.6.2 Installation:

1. Choose the correct clip for the application.
 - 1 a. Each clip can support 4,000 lbs.
 - 1 b. Standard clips are rated for up to 180°F, while the High Temperature (HT) clips can be used for applications up to 340°F.
 - 1 c. Ensure the notch length of the clip is sufficient for the width of the pipe supports surface.
2. Determine how many clips will be required.

Table 3: I-Rod Clips Required

Nominal Pipe Size (IN)	No. Clips Required (Cradle)	No. Clips Required (Clamp)
4	2	4
6	2	6
8	4	8
10	4	8
12	4	8
14	4	8
16	6	10
18	6	10
20	6	10
24	6	12
28	8	14
30	8	16

3. Clean the pipe support surface if using double sided tape on the bottom of the I-Rod clips .
4. Install the correct number of clips on the support in an approximate evenly spaced arrangement .

12.6.3 I-Rod Stock Codes

Stock Code	Descriptions	Use
49 62 053	3-1/2" Long with Adhesive Strip	2-1/2" – 12" Pipe Supports
49 62 054	1" x 5' Long Strip	Cut to Lengths Needed

12.7 Nu-Bolts

12.7.1 Nu-Bolts are a combination of a half cylinder spacer, with a polyshrink coated U-bolt. These fittings can be used to secure pipe on flat surface pipe supports.



Figure 7: Nu-Bolts

12.7.2 Installation:

1. Use the correct size:
 - 1 a. Diameter of I-Rod (three sizes available)
 - (i) 3/4" – No maximum loading information available. (Recommended to use either 1" or 1-1/2")
 - (ii) 1" – The maximum loading for each rod is 8,000 lbs.
 - (iii) 1-1/2" – The maximum loading for each rod is 10,000 lbs.
 - 1 b. Width of U-Bolt.
2. Use the correct I-Rod material:
 - 2 a. Standard clips as rated to 180°F.
 - 2 b. High Temperature (HT) can be used for applications up to 340°F
3. There may be a need to use additional I-Rod strips to achieve the proper weight loading .
4. Clean the metal surface if using double sided tape on the bottom of the I-Rod strip(s).
5. Place the I-Rod strip(s) on the flat metal surface instead of directly on concrete for even weight loading .
6. Set the pipe on the I-Rod strip(s) and secure with the coated U-bolt, tightening down the nuts to hold the fitting and pipe in place .

12.7.3 Nu-Bolt Stock Codes

Stock Code	Fits Pipe Size (Inches IPS)	Description
21 96 288	2	Coated 3/8" U bolt, half-round I-Rod clip, 4 Hex Nuts
21 96 291	4	Coated 1/2" U bolt, half-round I-Rod clip, 4 Hex Nuts
21 96 292	6	Coated 5/8" U bolt, half-round I-Rod clip, 4 Hex Nuts

UNCONTROLLED IF PRINTED

21 96 293	8	Coated 5/8" U bolt, half-round I-Rod clip, 4 Hex Nuts
21 96 294	10	Coated 3/4" U bolt, half-round I-Rod clip, 4 Hex Nuts
21 96 295	12	Coated 7/8" U bolt, half-round I-Rod clip, 4 Hex Nuts

End of Instructions.

Operator Qualification (OQ) Required?

YES

0001: Measure Structure- to-Electrolyte Potential

0011: Conduct Close Interval Survey

0021: Measure Soil Resistivity

0031: Inspect and monitor Galvanic Ground Beds/Anodes

0041: Installation and Maintenance of Mechanical Electrical Connections

0051: Installation of Exothermic Electrical Connections

0061: Inspect or Test Cathodic Protection Bonds

0071: Inspect or Test Cathodic Electrical Isolation Devices

0081: Install Cathodic Protection Electrical Isolation Devices

0091: Troubleshoot In- Service Cathodic Protection System

0101: Inspect Rectifier and Obtain Readings

Appendices

[Appendix A - Short Detection Diagrams](#)

[Appendix B - Cased Crossing Monitoring](#)

[Appendix C - Equipment](#)

Attachments

NONE.

Compliance Requirements

NONE.

Reference Documents

[CORR 2.3 Corrosion Control: Coatings](#)

Document Rescission

CORR 2.7 Corrosion Control: Short Investigation and Clearing Shorted Pipelines, April 1, 2021.

Revision Notes

UNCONTROLLED IF PRINTED

Location of Changes	Summary of Changes
Paragraph 12.6.3	Stock Codes for I-Rod clips
Paragraph 12.7.3	Stock Codes for Nu-Rods

Appendix A - Short Detection Diagrams

A-1. Null Method

A-1.1 Signal Direction and Nulling

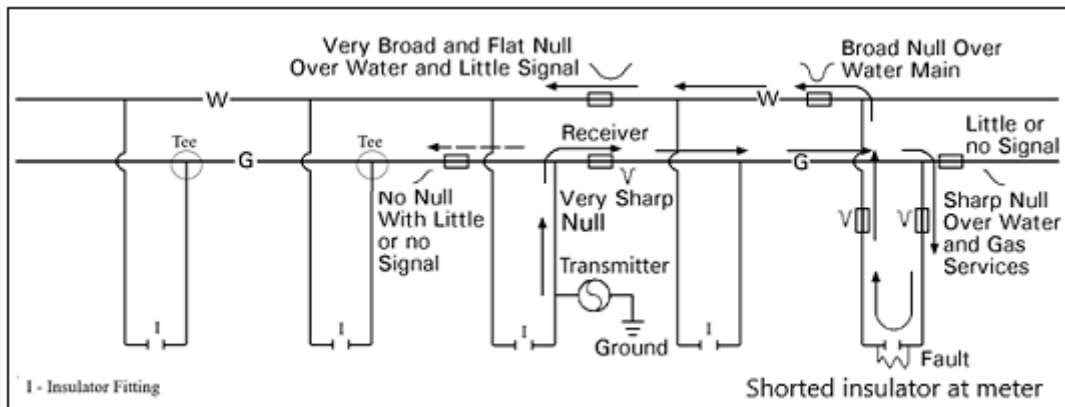

A-1.2 Water Service Shorted to a Gas Main

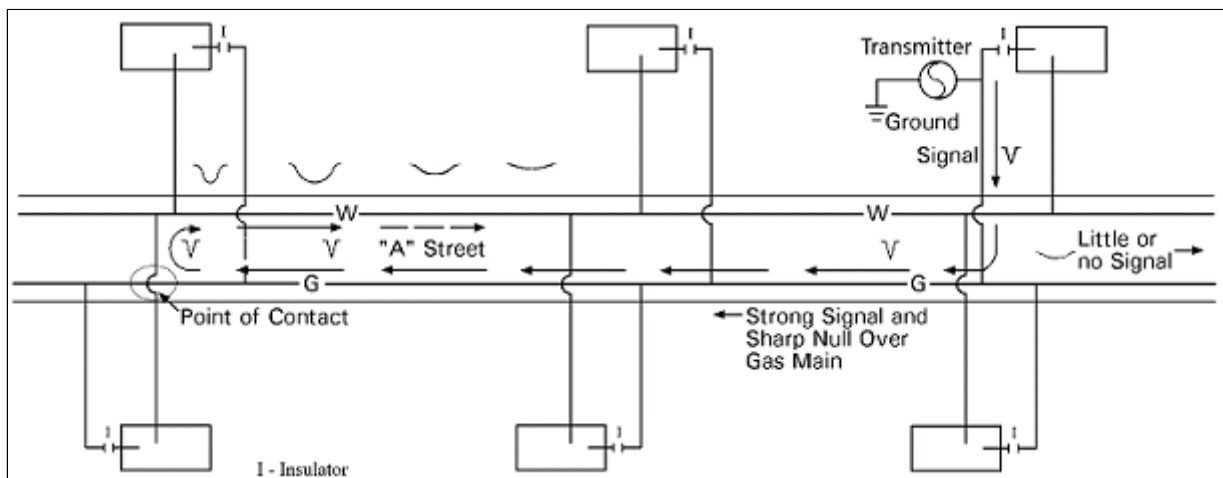

A-1.3 Shorted Meter Set

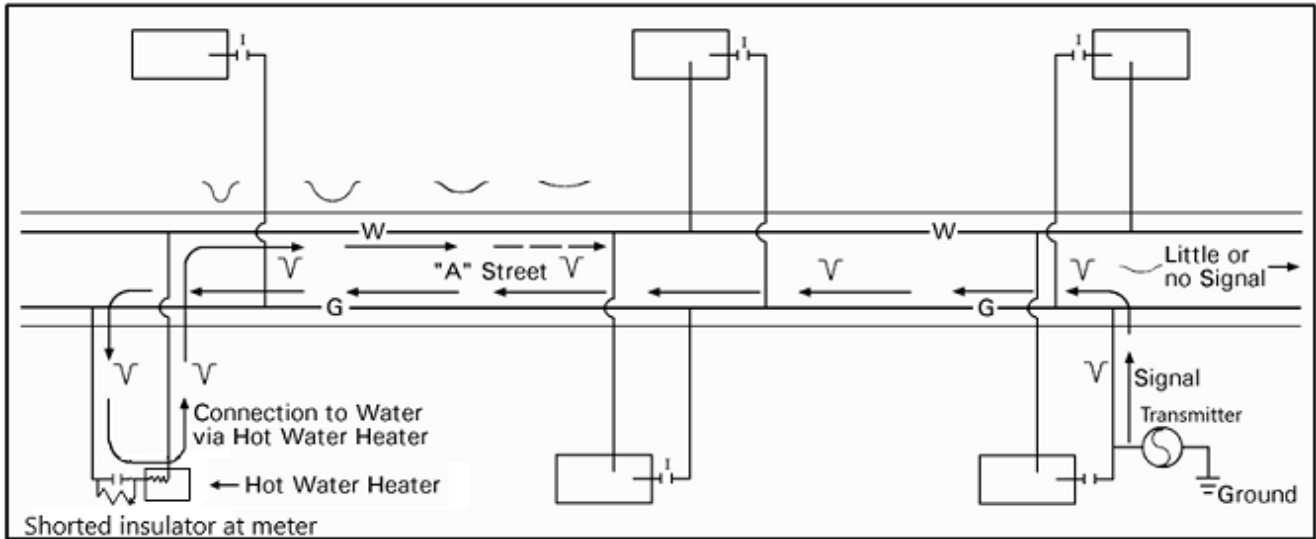

A-2. Peak Method

A-2.1 Signal Direction and Peaking

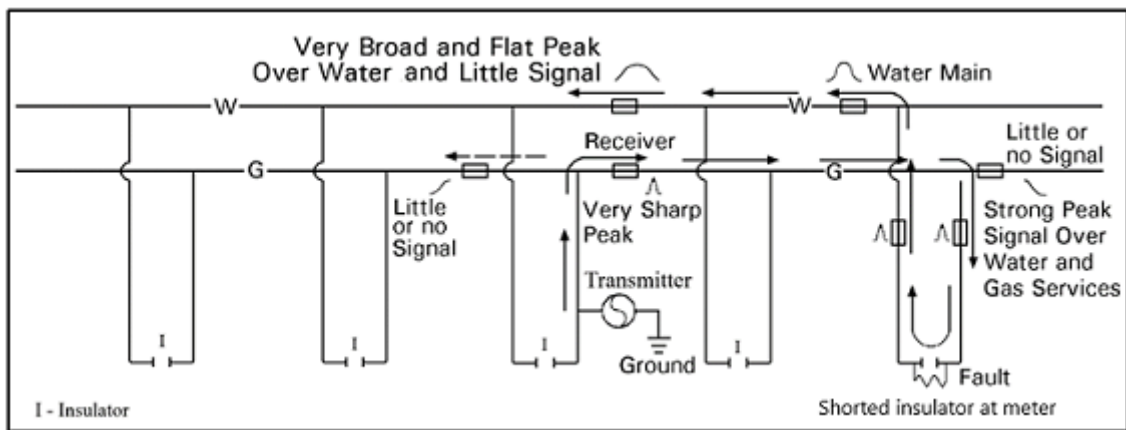

A-2.2 Water Service Shorted to a Gas Main

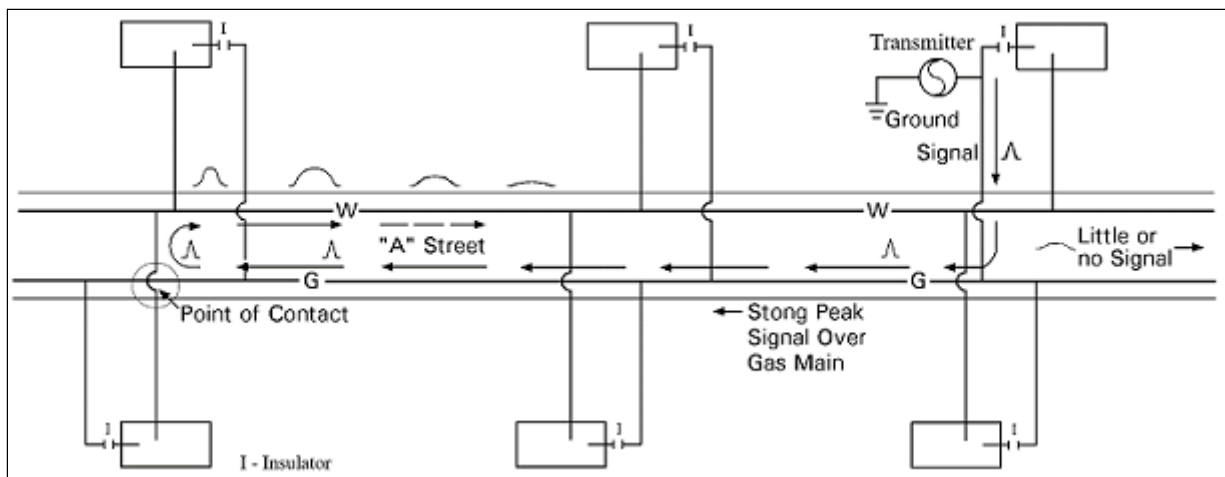

A-2.3 Shorted Meter Set

UNCONTROLLED IF PRINTED

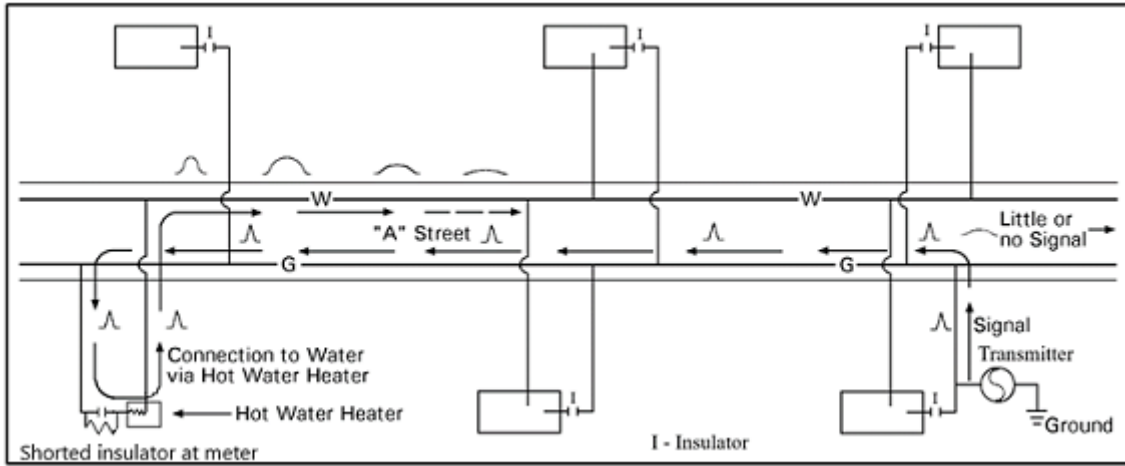

Appendix B - Cased Crossing Monitoring

Typical Casing Installation

1. General

- A. This standard details the requirements for cathodic protection monitoring of cased crossings.
- B. Casings for the purpose of this standard involve a steel carrier pipe and a steel casing pipe.
- C. For the purposes of cathodic protection monitoring, each casing needs an electrically continuous connection to the carrier pipe and to the casing.
- D. Only one set of connections are required per cased crossing.
- E. The main connection may be any electrically continuous facility such as a test lead, farm tap, service, or riser pipe.
- F. The casing connection can be either a vent pipe or test lead connected to the casing. Vent pipes shall be welded or if couplings are used, couplings will be strapped for continuity.

2. Typical Casing Installation

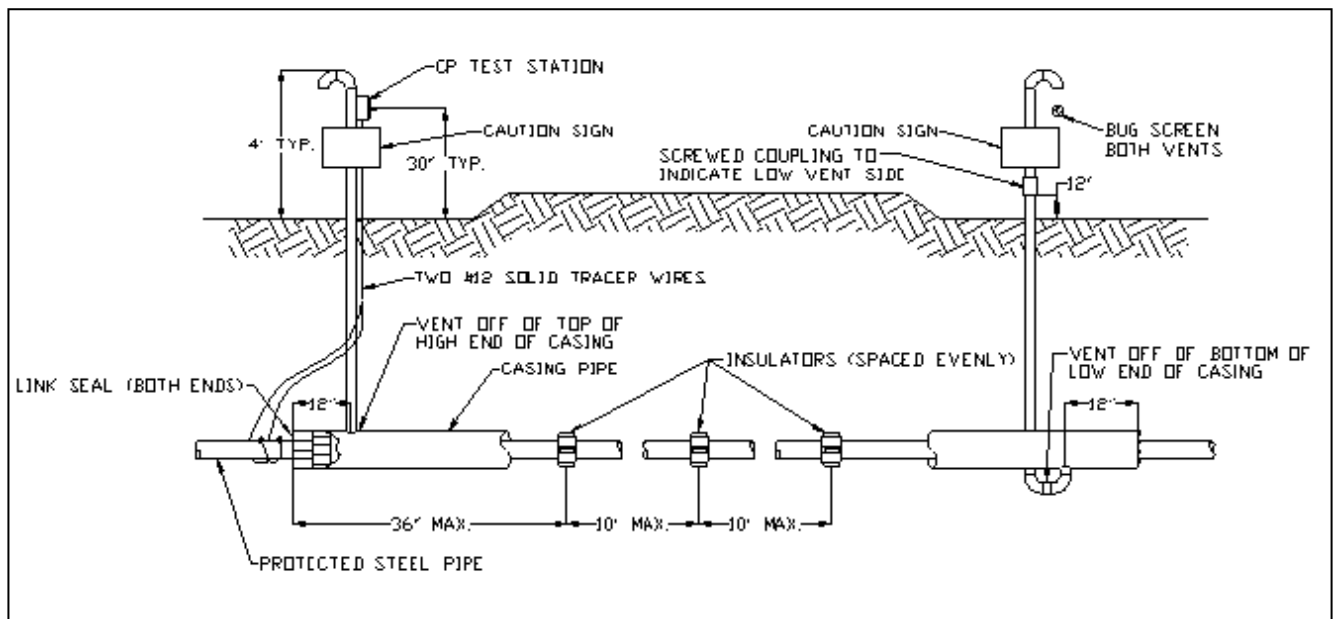

Appendix C - Equipment

UNCONTROLLED IF PRINTED

C-1. Radiodetection Pipeline Current Mapper (PCM)



PCM with short finding frequencies: 512Hz and 4 Hz

1. The Pipeline Current Mapper system enables the pipeline industry to map the current flow for cathodically protected pipes without installation of span test stations. This technology also is extremely useful in finding shorts caused by contact with other metallic structures.
2. The PCM system consists of a portable transmitter and a hand held receiver.
3. The transmitter applies a DC current to the pipeline.
4. The receiver locates this signal on the pipeline and displays the signal's current magnitude and direction without connection to the pipeline.
5. It provides a profile of the current and the current direction even in congested areas, as well as providing an accurate evaluation of the condition of the coating of the section of pipe.
6. An AC power source is required to operate the transmitter.

C-2. Tinker and Rasor Locator

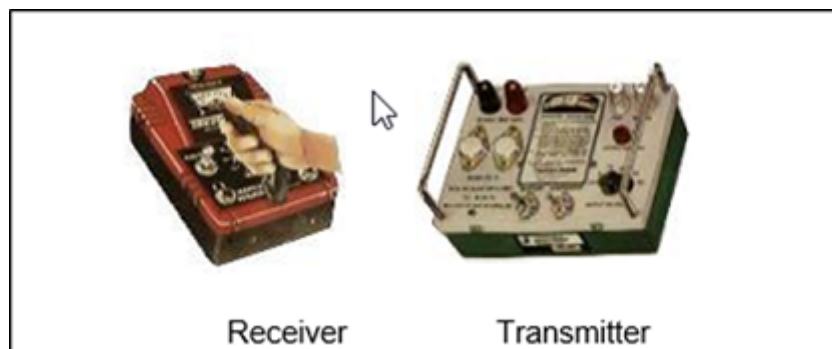

Tinker and Rasor Short Locator with short finding frequency of 750 Hz.

1. The search coil is contained within the receiver. Although earphones are furnished for operator's optional use, the loudspeaker offers advantages related to safety, convenience, and comfort.
2. A signal of 750 Hz is generated by using a power transistor switching circuit.
3. In order that a maximum of energy can be transferred from the transmitter to the pipe, the output of the transmitter is provided with taps so that voltages of 2.5, 5, 7.5, 15, 50, and 100 volts are available to match the load.
4. An interrupter is provided to make the signal more easily recognized.

C-3. vLocPro Pipe Locator

UNCONTROLLED IF PRINTED



vLocPro with short finding frequency of 512 Hz and signal direction

1. The vLocPro is intended for use by field technicians to locate, trace and the position of buried utility pipes and cables.
2. Features
 - a. Digital receiver with interference filters.
 - b. Fast, clear, positive response even in congested areas.
 - c. Multiple active frequencies and modes provide sophisticated location tools.
 - d. Peak, null and single antenna modes.
 - e. Position and depth measurement.
 - f. Current measurement to identify individual networks.
 - g. High output Transmitter.
 - h. Current direction which helps distinguish target lines from foreign facilities and can be used to find shorts in loops.

C-4. Radiodetection RD4000 Pipe Locator

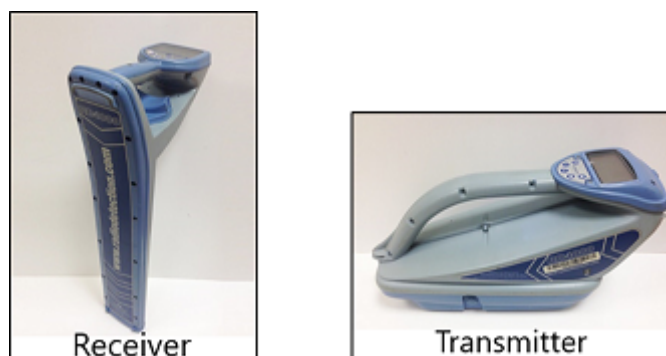

Radiodetection RD4000 with short finding frequency of 512 Hz and signal direction

1. The Radiodetection RD4000 cable and pipe locator has multiple locate modes for locating utilities, marking for construction, mapping or fault (short) finding
2. Features
 - a. Digital receiver with interference filters.
 - b. Fast, clear, positive response even in congested areas.
 - c. Multiple active frequencies and modes provide sophisticated location tools.
 - d. Peak, null and single antenna modes.

UNCONTROLLED IF PRINTED

- e. Position and depth measurement.
- f. Current measurement to identify individual networks.
- g. High output Transmitter.
- h. Current direction which helps distinguish target lines from foreign facilities and can be used to find shorts in loops.

C-5. Tinker and Razor CS-1 Current Source



Tinker and Razor CS-1

1. The CS-1 portable Magnesium Anode Simulator is a DC current source that will allow the user to see what the addition of a magnesium anode on their system will do to Pipe to Soil measurements and other C.P. tests.
2. Features
 - a. 1.7 Amps adjustable output
 - b. LCD Display Shows Amps and Voltage
 - c. 1 milliamp resolution
 - d. Simulates a standard Mag. Anode
 - e. Internal replacement battery
 - f. Provides "What If" on pipeline
 - g. MIL-SPEC Instrument case
 - h. Adjustable Current

CORROSION CONTROL

October 1, 2022

CORR 2.8 Cathodic Protection Testing

1.0 Purpose

The purpose of this document is to provide guidance in how to test the adequacy of cathodic protection to Ameren's pipeline system in compliance with 49 CFR §§ 192.473, 192.469, and 192.471.

2.0 Scope

This document addresses the following:

[3.0 Target Audience](#)

[4.0 Close Interval Survey](#)

[5.0 Soil Resistivity Testing](#)

[6.0 Monitor Galvanic Anode Bed Output](#)

[7.0 Install and Maintain Mechanical Electrical Connections](#)

[8.0 Test Electrical Isolation Devices](#)

[9.0 Test Points](#)

[10.0 Bonds](#)

[11.0 Cased Crossings](#)

[12.0 Major Foreign Pipeline Crossing](#)

[13.0 Test Point Verification](#)

Appendices

[Appendix A - Cathodic Test Stations](#)

[Appendix B - Test Lead Wire Attachment](#)

[Appendix C - Equipment](#)

3.0 Target Audience

- Corrosion Control Supervisors
- Corrosion Control Specialists

4.0 Close Interval Survey

4.1 A Close Interval Survey is a series of pipe-to-soil potentials taken over a section of pipeline that can be used as a diagnostic tool to identify insufficient cathodic protection (cp), damaged coatings, foreign contacts or stray current interference.

4.1.1 Ensure that the AC voltage sensing device is functioning properly.

4.1.2 Test structure for AC voltage prior to touching it.

4.1.3 Locate pipeline for length to be surveyed.

4.1.4 Connect survey wire to pipeline.

UNCONTROLLED IF PRINTED

4.1.5 At the prescribed intervals (usually 3 to 10 feet) perform a pipe-to-soil test as described below

4.2 Digital Multimeter with Half-Cell

4.2.1 Connect leads from voltmeter.

1. Red lead to volt/ohm terminal.
2. (Black lead to common terminal.

4.2.2 Select VDC (volts direct current) choice on voltmeter

4.2.3 Connect the clip end of the red lead to the survey wire and the survey wire to the pipe or structure to be tested.

4.2.4 Connect the clip end of the black lead to the half-cell.

4.2.5 Remove the orange protective cap from the reference electrode.

4.2.6 Place the porous plug of the electrode into moist soil.

4.2.7 Observe and record the reading to at least 2 decimal places.

5.0 Soil Resistivity Testing

5.1 Soil resistivity testing tests the property of the soil that resists current flow. There are 3 primary techniques: Four pin, single pin and soil box.

5.1.1 Four pin

1. The pin spacing is equal to the depth of the soil resistivity measurement taken. See [Figure 1](#).
2. Pins should be placed at least 15 feet away from any other buried structure.

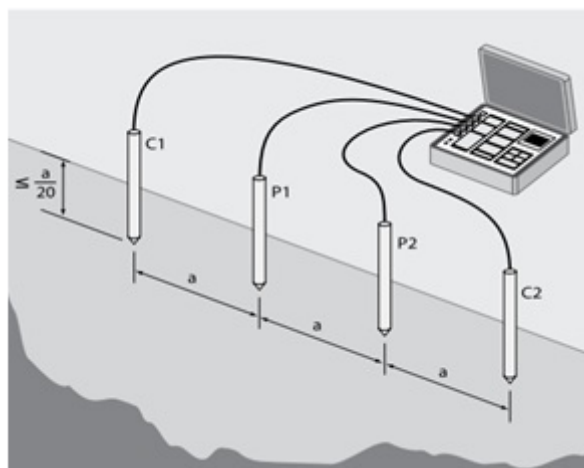

Figure 1 Four Pin Method Schematic

5.1.2 Single pin

1. Resistivity measured is of the soil in a sphere around the point of the probe. See Figure 2.

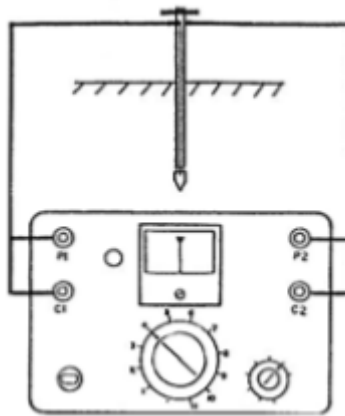

Figure 2 Single Pin Method Schematic

5.1.3 Soil box

1. Soil must be excavated and placed in the box.
2. Test can be performed with a 4 pin meter. See Figure 3 and [Appendix C-3](#).

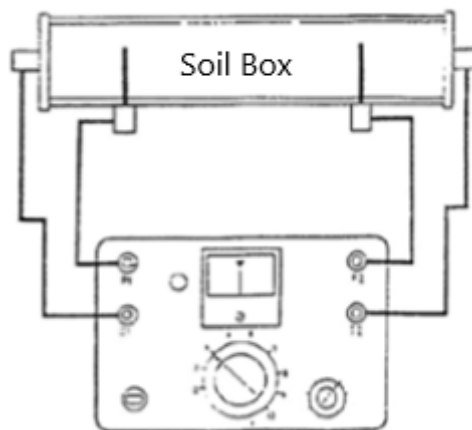

Figure 3 Soil Box Resistivity Measurements

5.2 Four Pin Method (See [Figure 1](#) and [Appendix C-1](#))

- 5.2.1 Test the meter's battery
- 5.2.2 Find a suitable location for testing soil resistivity. The soil should be of the same type along the entire path of the pins C1, P1, P2 and C2.
- 5.2.3 Place the pins perpendicular to the path of the survey. The distance between each pin should be identical. The distance between each pin (Pin Separation) is equal to the depth that the soil resistance is desired. Pins should be inserted into the ground no deeper than about 2 inches per 3 feet of distance between the pins.
- 5.2.4 Connect cables between each pin and the corresponding terminal on the meter panel.
 1. Connect C1 on the meter panel to the first pin, closest to the instrument.
 2. Connect C2 on the meter panel to the last pin, farthest from the instrument.
 3. P1 should be connected to the second pin from the instrument, and

UNCONTROLLED IF PRINTED

4. Connect P2 to the third pin from the instrument.
- 5.2.5 Move the RANGE SELECTOR on the meter panel to the lowest level. Refer to [Appendix C-1](#).
- 5.2.6 Activate the meter. (Nilson meter must be "nulled" to obtain the resistance measurement)
- 5.2.7 If the resistance measurement exceeds meter range, move the range selector to the next level and repeat until a resistance reading can be measured.
- 5.2.8 Calculate the resistivity: Resistivity (ohm-cm) = (resistance reading measured) X (range selector position (1, 10, 100, etc.)) X (pin spacing) X (191.5).
- 5.3 Single Probe Method (See [Figure 2](#) and [Appendix C-2](#))
 - 5.3.1 Test Device
 1. Disconnect leads from soil rod.
 2. Turn power switch to "ON".
 3. Push & hold test switch "UP".
 4. While holding, move dial pointer until tone "NULLS". Reading on dial should match test position value, if not, reset pointer.
 5. Push & hold test switch "DOWN".
 6. Repeat item "4" above.
 - 5.3.2 Test Soil Resistivity
 1. Insert soil rod in soil to depth to be tested,
 2. Connect leads to soil rod and binding posts on Model 54-A marked "LEADS". See [Appendix C-2](#).
 3. Plug ear set into jack marked "PHONES"
 4. Flip toggle switch to "ON" position, bring tone to "NULL" by means of dial pointer.
 5. The resistance of the soil will be the dial reading in Ohms-cm.
- 5.4 Soil Box Method (See [Figure 3](#) and [Appendix C-3](#))
 - 5.4.1 Place soil in soil box
 - 5.4.2 Use a 4 pin meter to measure the soil resistivity
 - 5.4.3 Connect C1 lead to left end of box and C2 to the right end
 - 5.4.4 Connect P1 to the left pin on the front of the box and P2 to the right pin
 - 5.4.5 The soil boxes are designed such that the cross-sectional area of the sample, with the box filled level, divided by the separation between the interior pins is equal to 1cm.
 - 5.4.6 The resistance measured equals the resistivity in ohm-cm.

6.0 Monitor Galvanic Anode Bed Output

- 6.1 There are 2 methods to measure current output from galvanic anode installations.
 - 6.1.1 Measure current output using a calibrated shunt and a multimeter.

6.1.2 Measure current by placing an ammeter or multimeter in the circuit.

1. Both methods require leads be brought above ground.
2. Zero output usually means a wire is broken.
3. Low output could be caused by dry soil conditions or depleted anodes.

6.2 Calibrated Shunt and Multimeter Method

6.2.1 Check connections in test station to ensure connections are clean and tight.

6.2.2 Locate the calibrated shunt in the test station.

6.2.3 Place the positive lead on the pipe side of the shunt and the negative lead on the anode side of the shunt. See Figure 4.

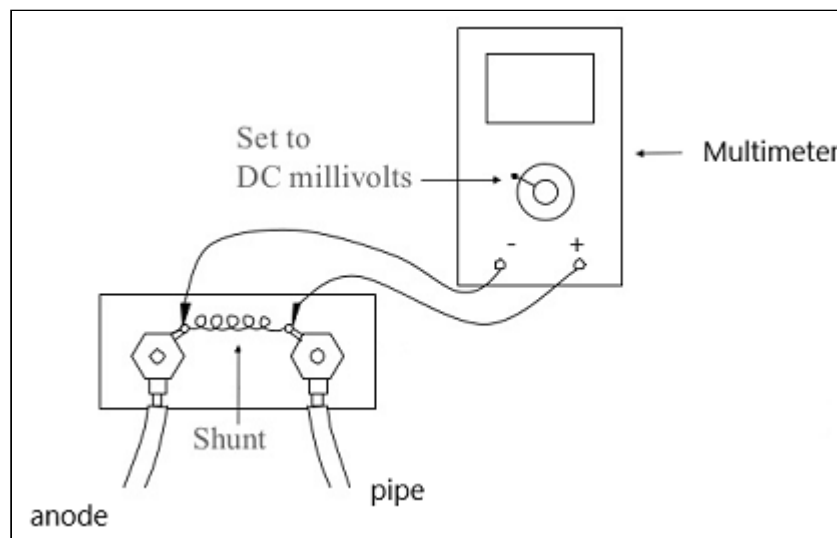

Figure 4 Shunt and Multimeter Methods

6.2.4 Set the multimeter to mV.

6.2.5 Observe and record the reading.

6.2.6 A positive reading indicates anode output.

6.2.7 Calculate the current flow. $\text{Current (amps)} = (\text{mV reading} / 1000) / (\text{shunt resistance})$.

6.2.8 Document the reading.

6.3 Multimeter in circuit method

6.3.1 Check connections in test station to ensure connections are clean and tight.

6.3.2 Disconnect wire to pipe and wire to anodes.

6.3.3 Connect the positive side of the meter to the pipe wire and the negative side of the meter to the anode wire. See Figure 5.

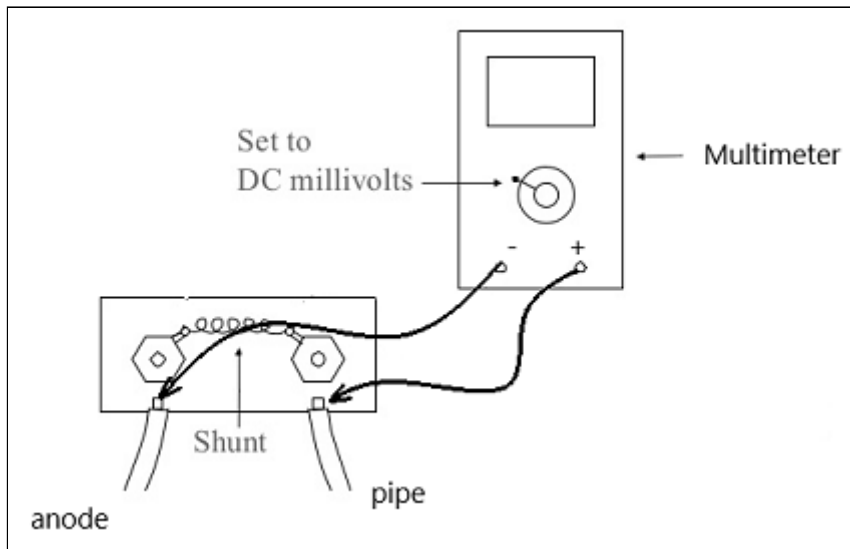

Figure 5 Multimeter in circuit Method

- 6.3.4 Set the meter on DC amps or milli-amps.
- 6.3.5 Observe and record the reading.
- 6.3.6 A positive reading indicates anode output.
- 6.3.7 Disconnect the meter and reconnect the pipe and the anodes.
- 6.3.8 Document the reading.

If the current output exceeds the amp rating of the multimeter setting, an internal fuse will blow and need to be replaced.

7.0 Install and Maintain Mechanical Electrical Connections

- 7.1 Mechanical electrical connections, i.e. tracer wire, test leads, bonding wires may be joined with a split bolt connector (Kearney) or terminated with a loop connector. See [Figure 6](#) and [Figure 7](#).

These connections are required to maintain CP and measure the CP system performance.



Figure 6 Kearney Connector



Figure 7 Loop/Ring Connector

- 7.1.1 Wire connections may be required for continuity bonds, critical bonds, tracer wire connections, or anode connections.
- 7.1.2 Connections must be clean, tight and protected from moisture.
- 7.1.3 Twisting of wire is not an acceptable connection.
- 7.1.4 Approved materials must be used.
- 7.1.5 Ensure leads are not stressed during backfill operations.
- 7.1.6 Buried connections must be coated.
- 7.1.7 Ensure that all test lead and anode installations are mapped.
- 7.2 Make mechanical wire connection.
 - 7.2.1 Strip wire.
 - 7.2.2 Tighten connector.
 - 7.2.3 Test the integrity of connection.
 - 7.2.4 Continuity test if applicable.
 - 7.2.5 Seal the connection.

8.0 Test Electrical Isolation Devices

- 8.1 A pipeline electrical isolation device may be tested by the following methods:

UNCONTROLLED IF PRINTED

- 8.1.1 Application of current to the structure using an interrupter. Check for potential shift on each side of the insulator.
- 8.1.2 Connect a low frequency locator (less than 800 hz) to the structure. Locating signal (less than 800 hz) will not pass through a fully functioning isolation device.
- 8.1.3 Use an RF insulation checking device designed to check pipeline insulators. See [Appendix C-4](#).
- 8.1.4 Place a half cell at a location. Without moving the half cell test the pipe-to-soil potential of the pipe on both sides of the insulator. If the potentials are more than 20mV different then the insulation is good. Less than 20mv requires additional testing.

9.0 Test Points (49 CFR 192.469 and 192.471)

- 9.1 Refer to [Appendix A](#) for different types of cathodic test stations.
- 9.2 To determine protective levels of cathodically protected structures:
 - 9.2.1 Establish at least 1 test point on each cathodically protected structure.
 - 9.2.2 Locate test points to represent the potential of adjacent piping.

There should typically at least 1 test point in each quarter section.

- 9.2.3 Every ½ mile to 1 mile on cross-country pipelines unless terrain or land use requires farther spacing.
- 9.2.4 Test point spacing should not exceed 1-½ miles without data that proves protection between test points.
- 9.2.5 Establish additional test points if the gas system geometry, pipe surface area, or history of the structure indicates need for closer monitoring.
- 9.2.6 The following are recommended for use as annual test points:
 - 1. System pressure control stations (inlet and outlet).
 - 2. Major river crossings (read on both sides of the crossing).
 - 3. Gas storage wells (current drains on impressed current systems and pipe-to-soil potentials on magnesium anode systems).
 - 4. Farm taps.
 - 5. Test leads.
 - 6. Steel services.
 - 7. Service tracer wire bonded to a steel main

10.0 Bonds

- 10.1 Measuring current using a shunt with a multimeter.
 - 10.1.1 Connect the red lead to Ameren Illinois' side and the black lead to foreign side of the shunt on the "ears" provided.
 - 10.1.2 Set the multimeter to DC mV scale.
 - 10.1.3 Record the DC mV reading.

UNCONTROLLED IF PRINTED

- 10.1.4 To convert to amps, divide the DC mV reading by 1000 and divide results by the resistance of the shunt.

Example: $\left(\frac{50 \text{ DC mV}}{1000}\right) \div 0.01 \text{ ohm} = 5 \text{ amps}$

For 0.01 ohm shunts, move the decimal point of the mV reading 1 place to the left to convert to amps.

10.2 Interpretation

- 10.2.1 When the reading is positive, Ameren Illinois is returning current to the foreign line. When the reading is negative, the foreign line is returning current to Ameren Illinois.

11.0 Cased Crossings

- 11.1 Comparison between pipe-to-soil potential and casing-to-soil potential.

11.1.1 Both potentials should be measured with the half-cell in the same location for a valid comparison.

11.1.2 If the difference in potentials is less than 25 mV additional tests for isolation shall be performed. See [CORR 2.7](#).

- 11.2 If it is necessary to perform pipe-to-soil readings at different nearby locations, additional testing for isolation shall be performed if the difference in potentials is less than 200 mV.

1. If the casing is documented as shorted and is filled with dielectric filler, only a pipe-to-soil potential for the pipeline is required.
2. Cased crossings with plastic mains do not need to be monitored for electrical isolation.

12.0 Major Foreign Pipeline Crossing

- 12.1 Measure the pipeline's potential as near to directly over the actual point of crossing, as possible. Refer to [Figure 8](#).

12.1.1 If the crossing is under pavement or water, measure a baseline potential at the crossing and another at the nearest assessable point.

12.1.2 The future potentials at the accessible point can be compared to the baseline crossing potential and further testing can be done whenever the accessible test point potential becomes less negative.

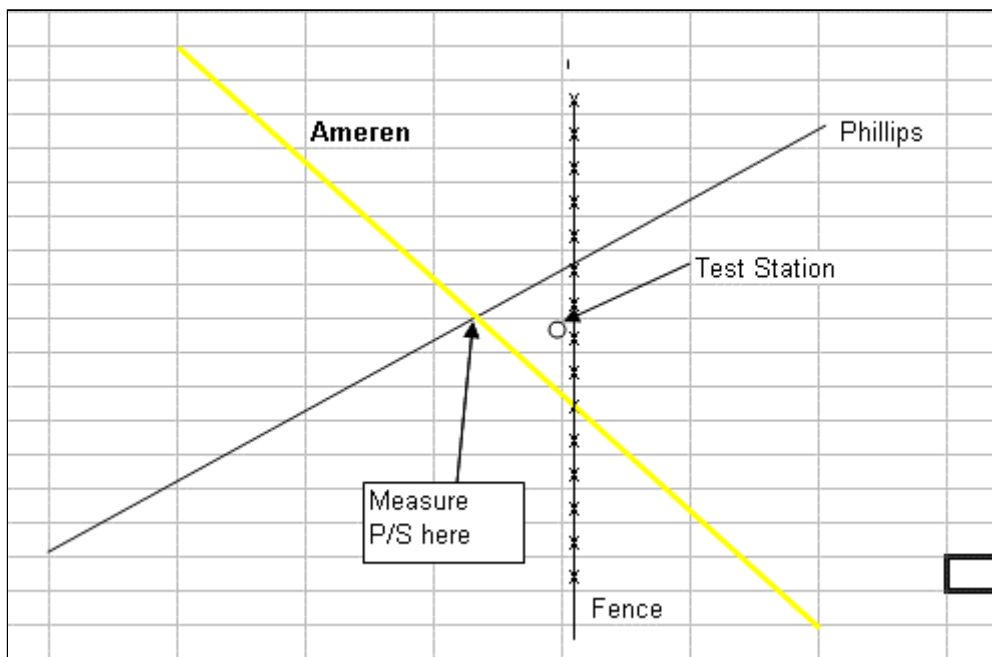

Figure 8 Foreign Pipeline Crossing Diagram

13.0 Test Point Verification

13.1 Use a current interrupter to apply current (or short out system) at another location on the structure and check the proposed test point for potential shift.

If the potential at the proposed test point shifts at a similar magnitude as the interrupter set up point, continuity is verified.

13.2 An alternative to the interrupter is a low frequency (below 800 Hz) locator. Connect the locator to the structure at a remote location and create a short at the test point of interest. If the test point can be located, continuity is verified.

Do not use a high frequency locator to prove test point continuity!

13.3 A welded steel service on a welded steel main can be assumed continuous with the main.

End of Instructions.

Operator Qualification (OQ) Required?

YES

0001: Measure Structure- to-Electrolyte Potential

0011: Conduct Close Interval Survey

UNCONTROLLED IF PRINTED

- 0021: Measure Soil Resistivity
- 0031: Inspect and monitor Galvanic Ground Beds/Anodes
- 0041: Installation and Maintenance of Mechanical Electrical Connections
- 0051: Installation of Exothermic Electrical Connections
- 0061: Inspect or Test Cathodic Protection Bonds
- 0071: Inspect or Test Cathodic Electrical Isolation Devices
- 0081: Install Cathodic Protection Electrical Isolation Devices
- 0091: Troubleshoot In- Service Cathodic Protection System
- 0101: Inspect Rectifier and Obtain Readings

Appendices

[Appendix A - Cathodic Test Stations](#)

[Appendix B - Test Lead Wire Attachment](#)

[Appendix C - Equipment](#)

Attachments

NONE.

Compliance Requirements

49 CFR §192.469 External corrosion control: Test stations.

49 CFR §192.471 External corrosion control: Test leads.

49 CFR §192.473 External corrosion control: Interference currents.

Reference Documents

[CORR 2.7 Corrosion Control: Short Investigation and Clearing Shorted Pipelines](#)

Document Rescission

CORR 2.8 Corrosion Control: Cathodic Protection Testing, May 15, 2022

Revision Notes

Location of Changes	Summary of Changes
Appendix B – Test Lead Wire Attachment - 7. C.	Removes Handy Cap as a Test Lead Attachment Coating. Product replaced by Viscotaq Coating Patch several years back.

Appendix A - Cathodic Test Stations

A-1. Single Test Lead - Flush to Grade Test Station

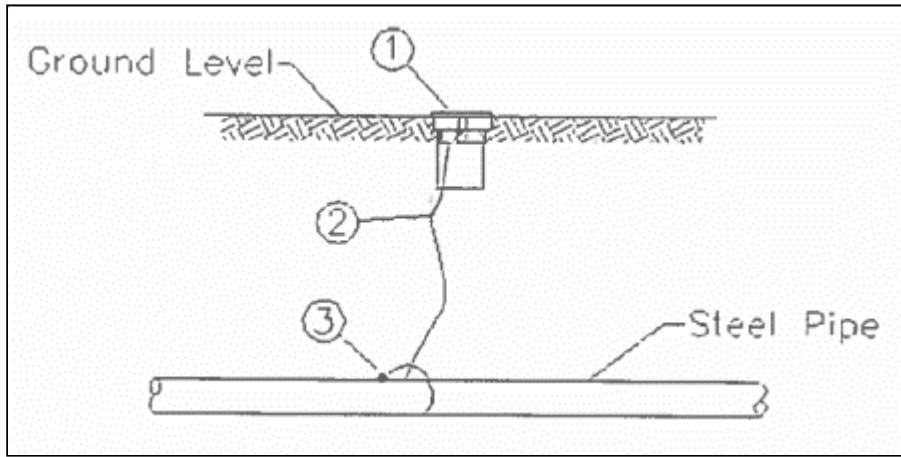

Installation

1. Test stations should be installed often enough to perform required operation and maintenance activities such as locating and cathodic protection testing.
2. Attach wire in accordance with [Appendix B](#).
3. Coat each connection according to the methods described in [Appendix B](#).
4. Loop wire around pipe outside of recoating area.
5. Terminate the test lead wire on a terminal in the test station.

Item	Stock No.	Description	Quantity
1	19 12 703	Box, CP Test 4 in ID x 18 in Lgh, Plastic w/Cast Iron Lockable Lid, 5 terminals, Marked "GAS TEST"	1
	19 12 696	Finklet	1
2	18 66 208	#12 Solid Copper Wire	X Feet
3	22 02 552	Thermite Cad Weld	1

A-2. Single Test Lead - Above Grade Test Station.

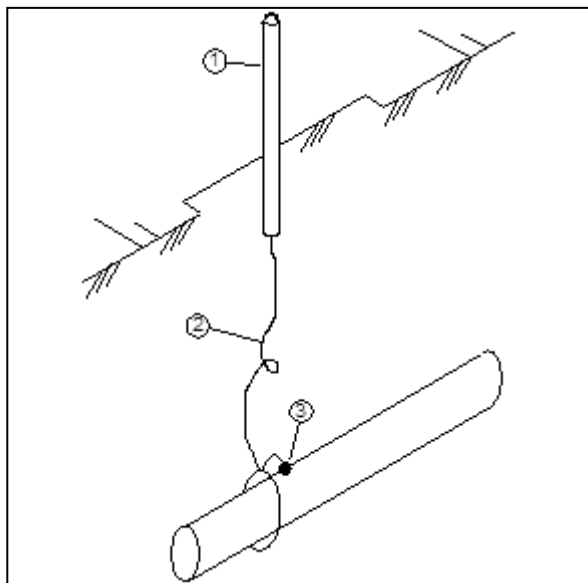
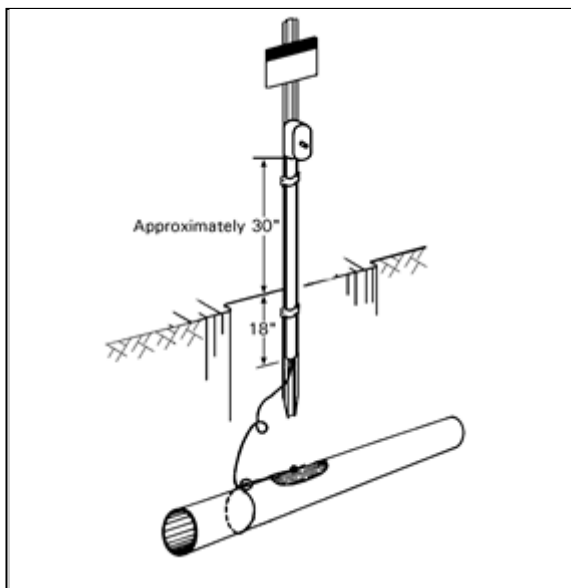



Finklet

Installation

1. Test stations should be installed often enough to perform required operation and maintenance activities such as locating and cathodic protection testing.
2. If using Finklet test station, install against existing pole, post, or marker.
3. Attach wire in accordance with [Appendix B](#).
4. Coat each connection according to the methods described in [Appendix B](#).
5. Loop wire around pipe outside of recoating area.
6. Terminate the test lead wire on a terminal in the test station.

Item	Stock No.	Description	Quantity
1	16 02 628	Pipeline marker, 3" diameter, 6 ft. long with Finklet Test Station on top.	1
	19 12 696	Finklet	1
2	18 66 208	#12 Solid Copper Wire	X Feet
3	22 02 552	Thermite Cad Weld	1

A-3. Foreign Pipeline Crossing Test Station

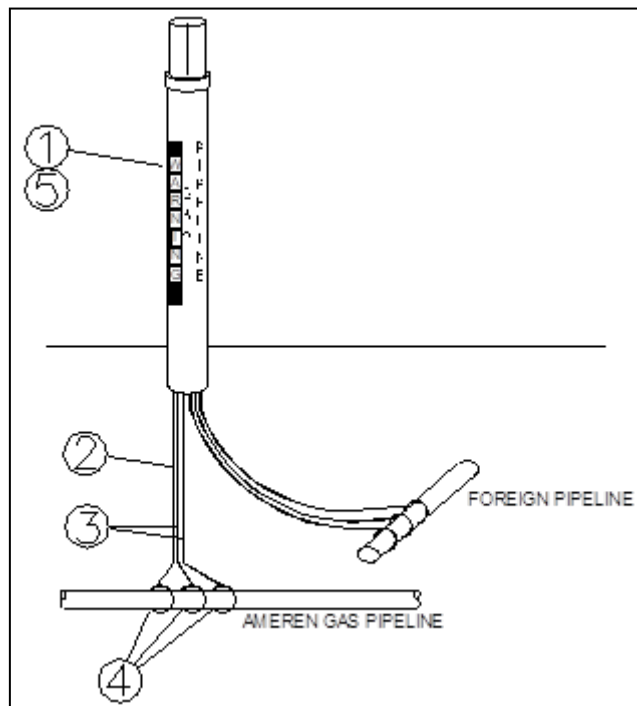

Installation

1. Attach 1 #8 and 2 #12 AWG - TW solid copper single conductor to Ameren's main.

2. Attachment of wires to foreign pipeline should be done by personnel from Pipeline Company.
3. Attach wires in accordance with [Appendix B](#).
4. Coat each connection according to the methods described in [Appendix B](#).
5. Terminate the test wires on terminals in the test station.
6. Consideration should be given to identifying test wire/lead connections.

Item	Stock No.	Description	Quantity
1	16 02 629	Pipeline marker, 3" diameter, 6 ft. long with bonding strap and a Big Finklet Test Station on top.	1
2	18 66 624	#8 Stranded Copper Wire	X Feet
3	18 66 208	#12 Solid Copper Wire	X Feet
4	22 02 552	Thermite Cad Weld	2
5	17 54 948	Connector, #14-#4 Wire	1

A-4. Inline Insulator - Above Grade Test Station

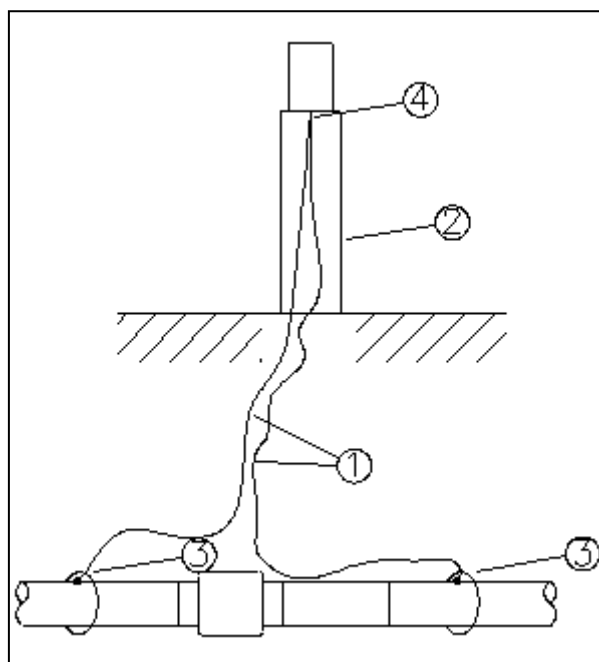

Installation

1. Attach wire in accordance with [Appendix B](#).
2. Coat each connection according to the methods described in [Appendix B](#).
3. Loop wire around pipe outside of recoating area.
4. Consideration should be given to identifying test lead/wire direction at insulators.
5. Terminate the test lead wire on a terminal in the test station.

Item	Stock No.	Description	Quantity
1	18 66 624	#8 Stranded Copper Wire	X Feet
2	16 02 629	Pipeline marker, 3" diameter, 6 ft. long with bonding strap and a Big Finklet Test Station on top.	1
3	22 02 552	Thermite Cad Weld	2
4	17 54 948	Connectors, #14-#4 Wire	2

UNCONTROLLED IF PRINTED

A-5. Inline Insulator - Flush to Grade Test Station

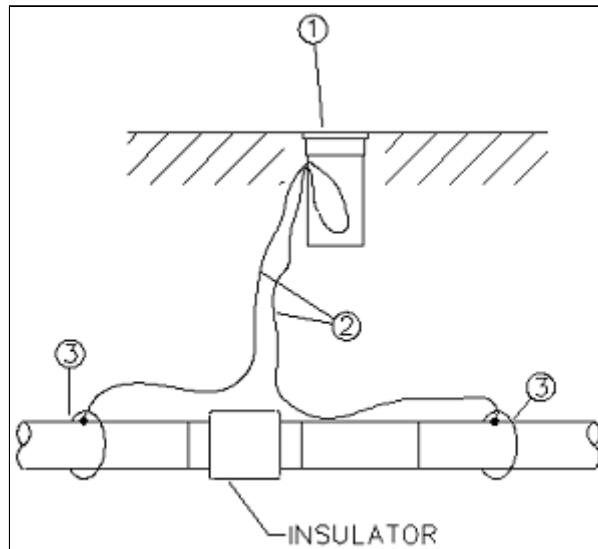

Installation

1. Attach wire in accordance with [Appendix B](#).
2. Coat each connection according to the methods described in [Appendix B](#).
3. Loop wire around pipe outside of recoating area.
4. Terminate the test wires on the terminals in the test station.
5. Consideration should be given to identifying test lead/wire direction at insulators.

Item	Stock No.	Description	Quantity
1	19 12 703	Box, CP Test 4 in ID x 18 in Lgh, Plastic w/Cast Iron Lockable Lid, 5 terminals, Marked "GAS TEST"	1
2	18 66 624	#8 Stranded Copper Wire	X Feet
3	22 02 552	Thermite Cad Weld	2

A-6. Insulated Valve - Underground

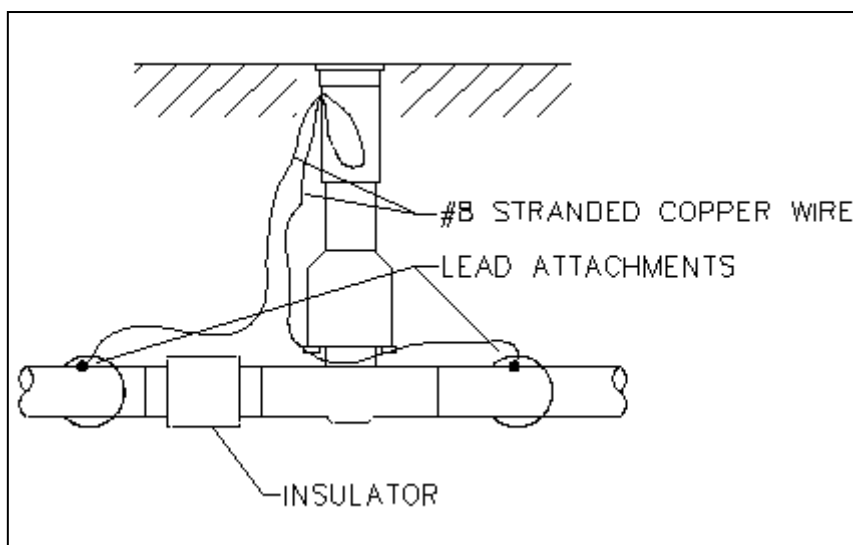

Installation

1. Attach wire in accordance with [Appendix B](#).
2. Coat each connection according to the methods described in [Appendix B](#).

UNCONTROLLED IF PRINTED

3. Loop wire around pipe outside of recoating area.
4. Run test lead up or outside of the box. Enter through hole near the top.
5. Cut wire and leave 12 inch slack wire inside valve box.
6. Install FPR insulators between a metal valve box and the protected main.
7. Terminate wires as show in construction drawing or neatly in valve box.
8. Consideration should be given to identifying test lead/wire direction at insulators.

A-7. Flange Fink Test Station - Test Leads Attached to Pipe

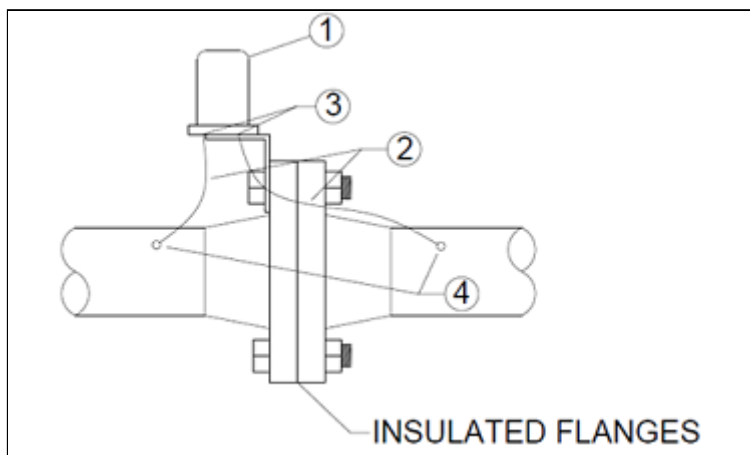

Installation

1. Attach wire in accordance with [Appendix B](#).
2. Coat each connection according to the methods described in [Appendix B](#).
3. Terminate the test leads on the terminals in the test station.

Item	Stock No.	Description	Quantity
1	19 12 699	Flange Fink	1
2	18 66 624	#8 Stranded Copper Wire	X Feet
3	17 54 948	Connector, #14-#4 Wire	2
4	22 02 552	Thermite Cad Weld	2
	or	or	
	21 76 626	Bolt, Hex, Head, 5/16" Dia. x 3/4" Long x 1/2" Head	1
	21 61 408	Nut, Hex, 5/16"	1
	23 66 187	Washer, Flat, 5/16"	2

A-8. Flange Fink Test Station - Test Leads Attached to Flanges

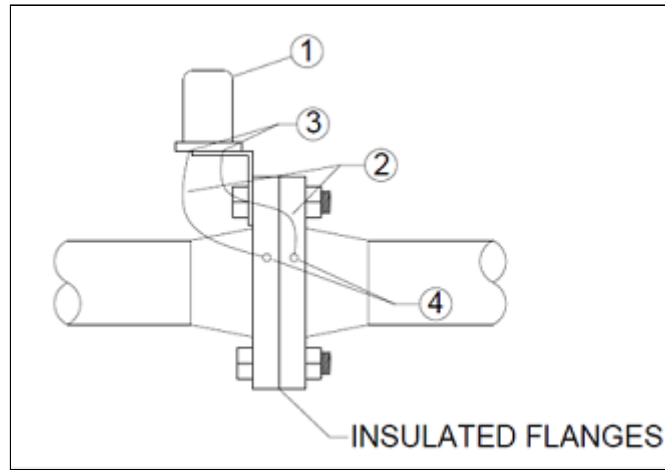

Installation

1. Attach wire to the outside edge of the flanges with either thermite weld or welded 5/16 inch bolt as described in [Appendix B](#). A 5/16 inch bolt can be welded on the edge of flange that is operating at any pressure.
2. Cover or protect the flange gasket from slag resulting from either the thermite weld or welding on a bolt.
3. Coat each connection according to the methods described in [Appendix B](#).
4. Terminate the test leads on the terminals in the test station.

Item	Stock No.	Description	Quantity
1	19 12 699	Flange Fink	1
2	18 66 624	#8 Stranded Copper Wire	X Feet
3	17 54 948	Connector, #14-#4 Wire	2
4	22 02 552	Thermite Cad Weld	2
		or	
	21 76 626	Bolt, Hex, Head, 5/16" Dia. x 3/4" Long x 1/2" Head Nut	1
	21 61 408	Nut, Hex, 5/16"	1
	23 66 187	Washer, Flat, 5/16"	2

A-9. AC Stray Current Test Station

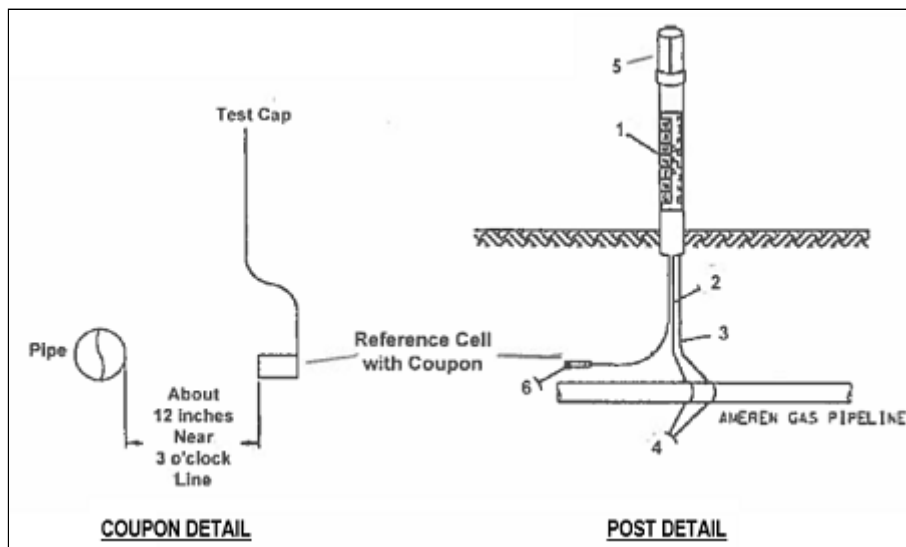

UNCONTROLLED IF PRINTED

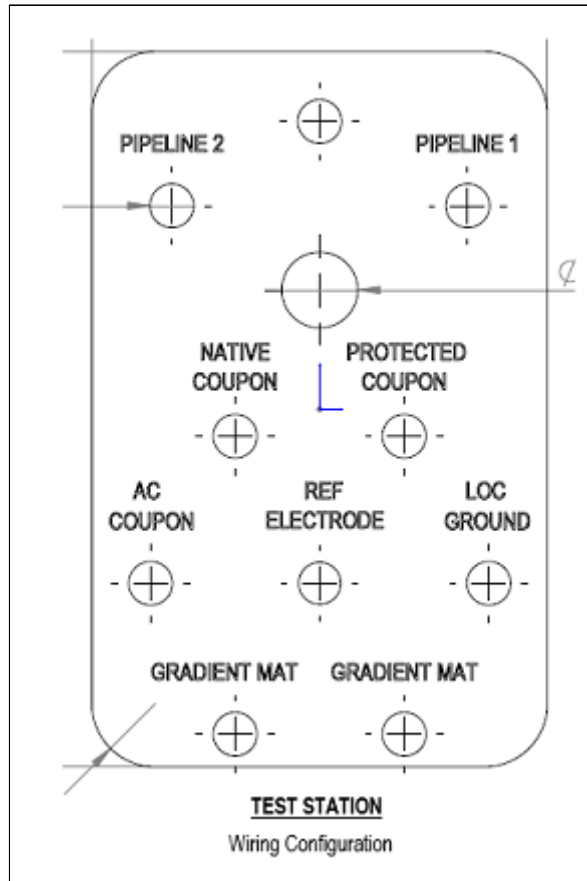

Installation

1. Connect # 8 AWG - Stranded copper wire to Ameren's main with Thermite Cad Weld or Pin Brazing and connect other end to the Pipeline Terminal 1 in Test Station.
2. Connect # 12 AWG - Tracer Wire, Solid Copper to Ameren's main with Thermite Cad Weld or Pin Brazing and connect other end to the Pipeline Terminal 2 in Test Station.
3. Locate the Reference Cell with Coupon housing approximately 12 inches away from the Ameren pipeline and near the 3 o'clock position.
4. Connect Reference Cell #14 AWG, RHH, RHW cable to the REF ELCTRODE Terminal in the Test Station.
5. Coupon housing contains three (3) coupons each has a #14 AWG, RHH, RHW cable.
 - A. Connect the Green colored cable to the NATIVE COUPON Terminal in the Test Station
 - B. Connect the Purple colored cable to the PROTECTED COUPON Terminal in the Test Station
 - C. Connect the White colored cable to the AC COUPON Terminal in the Test Station
6. Coat each thermite weld or Pin Brazing connection according to the methods described in [Appendix B](#).
7. Consideration should be given to identifying test wire/lead connections.

Item	Stock No.	Description	Quantity
1	19 12 710	Riser Pipe, HDPE, UV Resistant, 3.5 Inches OD, for use with Model T-3 Test Station, Earthlock anchor bar	1
2	18 66 624	#8 Stranded Copper Wire	X Feet

UNCONTROLLED IF PRINTED

3	18 66 208	#12 AWG, Tracer Wire, Solid Copper Wire, 500 Ft. Spool	X Feet
4	22 02 552	Thermite Cad Weld or Optional Pin Brazing	2
5	19 12 711	Model T-3 Custom Test Station, Engraved Terminal Board, 9 Rapid Connect Binding Posts, ShockGuard Cover and Toggle On/Off Switch, (Honeywell 1TL1-4), Yellow Cap	1
6	22 42 220	Stelth 7 REF CELL in Coupon Housing, C20IR, Free Reference Electrode, SRE-024-CIY-AC20	1

Appendix B - Test Lead Wire Attachment

1. General

- A. This standard prescribes the requirements for attaching wires to steel pipelines.
- B. The Cadweld thermite welding process using a #15 thermite cartridge, Cadweld Plus using a CA15PLUSF33 cartridge or Pin Brazing are the only approved methods of attaching lead wires to steel transmission mains or high pressure distribution main (MAOP > 100 psig).
- C. For distribution mains operating at or below 100 psig, test lead wires can be attached to the steel pipe by use of a welded bolt to the main, Cadweld thermite weld, Cadweld Plus or Pin Brazing processes.
- D. If multiple connections are made on the pipe, the connections should be at least six (6) inches apart.
- E. Do not attach wire within 2 inches of nearest girth weld.

2. Cadweld Thermite Welding Process

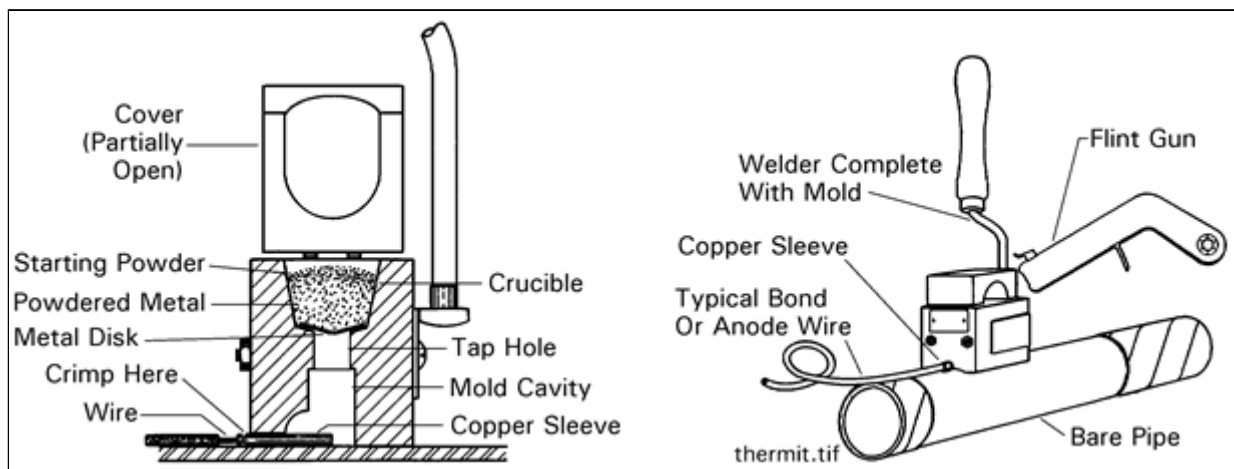

Typical Thermite Weld Configuration

A. Installation

- (1) Check environment with CGI if the presence of natural gas is possible.
- (2) Strip conductor insulation. Crimp sleeve to #12 and #14 wire. Sleeve is not required for #8 wire.
- (3) Remove coating down to bare metal in the proposed attachment location
- (4) Use a file, wire wheel, scraper, power brushes or grinder, or commercial blasting on the pipe until the bare metal is bright and shiny in the attachment location. If commercial blasting is used clean the grit or shot off the pipe after blasting.
- (5) Clean and dry pipe thoroughly before starting to weld.
- (6) Heat surface with torch to remove moisture from the pipe

UNCONTROLLED IF PRINTED

- (a) Be cautious not to damage the existing pipe coating during this step by keeping the torch moving.
 - (b) If there is PE pipe connected to the steel pipe, keep the torch flame away from the PE pipe or protect the PE pipe from the torch flame. Protection methods can be such as; covering PE pipe with backfill material, covering with non-combustible material, or placing a shield between the torch and PE Pipe, etc.
- (7) Tie wire around pipe.
 - (8) Leave sufficient slack to avoid stress on wire and connection when backfilling.
 - (9) Set clean and dry mold onto pipe.
 - (10) Place metal disk in the mold prior to pouring in powder.
 - (11) *Dump, do not pour*, container of welding powder into mold. Sprinkle some starting powder on the lip of the mold where the lid opening will be. Be sure all starting powder is removed from container. Never use a charge larger than 15 grams for steel pipe.
 - (12) Close lid and ignite with flint gun.
 - (13) Remove mold after about 10 seconds.
 - (14) Clean mold for next use.
 - (15) Clean slag off completed weld and test weld by pulling wire parallel to pipe.
 - (16) Coat connection in accordance with the Test Lead Attachment Coating section.

Notes:

- (a) *Ensure all surfaces are clean and dry.*

Caution: A wet mold or pipe may produce porous welds, splatter, or explosion during the welding process. Always wear approved eye protection and long gloves.

- (b) *Strike weld sharply to test for a good bond.*
- (c) *Molds should be replaced after 50 - 100 operations. A worn mold will not make adequate connections.*
- (d) *A torch may be used to dry a mold or pipe before use.*

3. CadWeld Plus Process

A. Installation

- (1) Check environment with CGI if the presence of natural gas is possible
- (2) Strip conductor insulation. Crimp sleeve to #12 wire.
- (3) Remove coating down to bare metal in the proposed attachment location
- (4) Use a file, wire wheel, scraper, power brushes or grinder, or commercial blasting on the pipe until the bare metal is bright and shiny in the attachment location. If commercial blasting is used clean the grit or shot off the pipe after blasting.
- (5) Clean and dry pipe thoroughly before starting to weld.
- (6) Heat surface with torch to remove moisture from the pipe
 - (a) Be cautious not to damage the existing pipe coating during this step by keeping the torch moving.

UNCONTROLLED IF PRINTED

- (b) If there is PE pipe is connected to the steel pipe, keep the torch flame away from the PE pipe or protect the PE pipe from the torch flame. Protection methods can be such as; covering PE pipe with backfill material, covering with noncombustible material, or placing a shield between the torch and PE Pipe, etc.
- (7) Tie wire around pipe.
- (8) Leave sufficient slack to avoid stress on wire and connection when backfilling.
- (9) Set clean and dry mold onto pipe.
- (10) Insert CADWELD PLUS, CA15PLUSF33 package into mold.
- (11) Attach Control Unit termination clip to ignition strip. Place baffle onto mold.
- (12) Press and hold Control Unit switch and wait for ignition.
- (13) Remove mold after about 10 seconds.
- (14) Clean mold for next use.
- (15) Clean slag off completed weld and test weld by pulling wire parallel to pipe.
- (16) Coat connection in accordance with the Test Lead Attachment Coating section.

Notes:

(a) *Ensure all surfaces are clean and dry.*

Caution: A wet mold or pipe may produce porous welds, splatter, or explosion during the welding process. Always wear approved eye protection and long gloves.

(b) *Strike weld sharply to test for a good bond.*

(c) *Molds should be replaced after 50 - 100 operations. A worn mold will not make adequate connections.*

(d) *A torch may be used to dry a mold or pipe before use.*

4. Material List

A. Cadweld Thermite Weld

Cadweld Thermite Weld Items						
Pipe Size	Mold	Wire Size	Sleeve	Sleeve Stock Code	Cartridge	Cartridge Stock Code
3/4" to 3-1/2"	CAHAA-1GA	14 - 10 Solid	CAB-133-1H	19 62 335	CA 15 / #15	22 02 552
		8 Str - 6 Solid	None			
4" & Larger	CAHAA-1G	14 - 10 Solid	CAB-133-1H	19 62 335		
		8 Str - 6 Solid	None			
Igniter						Non Stock

B. CadWeld Plus

CadWeld Plus Items						
Pipe Size	Mold	Wire Size	Sleeve	Sleeve Stock Code	Cartridge	Cartridge Stock Code
3/4" to 3-1/2"	CAHAA-1GA	14 - 10 Solid	CAB-133-1H	19 62 335	CA15PLUSF33	49 22 410
		8 Str- 6 Solid	None			

UNCONTROLLED IF PRINTED

4" & Larger	CAHAA-1G	14 - 10 Sol- id	CAB-133-1H	19 62 335	
		8 Str - 6 Solid	None		
Control Unit					Non Stock

5. Pin Brazing



Pin Brazing Equipment

A. Surface Preparation

- (1) Remove the pipe coating and grind or clean the area of connection onto the pipe to a clean bright metal finish. Also grind or clean an area nearby for the magnetic ground connection.
- (2) Degrease both cleaned areas and lightly abrade the area with a tool, i.e. hammer, to prepare for the lug attachment.

B. Loading the Pin Into the Brazing Gun

- (1) Load the gun with a brazing pin and ceramic ferrule individually by hand.
- (2) Ensure that they are both fully inserted and tight with the palm of your hand. **DO NOT STRAIGHTEN THE KINKED END OF THE PIN FUSE WIRE.**
- (3) The legs of the pin holder must be adjusted as necessary to ensure a firm grip of the pin while maintaining concentricity with the ferrule holder. *Important: Under no circumstances should a brazing pin which has been inserted and then removed from the gun be re-inserted and used for brazing without checking the kinked end profile and fuse wire connection to pin for damage.*

C. Adjustment of the Brazing Gun

- (1) Before connecting the ground device to the steel, adjust the brazing pin "Lift Height" as follows:

UNCONTROLLED IF PRINTED

- (a) Hold the cable lug or stinger flat on the steel surface (for direct pin connection).
- (b) Insert a loaded brazing pin into the hole in the lug and press the gun/ferrule against the surface of the lug evenly to overcome the internal spring.
- (c) Turn the ferrule holder until the white adjustment indicator tube is flush with the gun's rear face.
- (d) The brazing gun should now be correctly set. When using threaded brazing pins, i.e. M8 brazing pin, the ceramic ferrule must be flat against the steel surface when checking the white adjustment indicator tube.
- (e) Check the ceramic ferrule for damage and cracks prior to brazing as this could result in a malfunction of the braze connection.

D. Pin Brazing

- (1) Check environment with CGI if the presence of natural gas is possible. *Always wear approved eye protection and long gloves.*
- (2) The magnetic ground device must be applied to the cleaned surface of the pipe to ensure a sound electrical circuit.
- (3) The brazing gun must be correctly adjusted with the correct pin and ferrule fitted (see chart below).
- (4) Locate the brazing pin so that the pin is in the center of the hole in the cable lug. For vertical surfaces, the pin must be at the upper part of the hole in the cable lug.
- (5) Apply sustained pressure on the brazing gun so that full contact is made between the ferrule and the bond attachment (or the steel surface when using threaded pins).
- (6) The operator should look to one side to protect his eyes from glare and should use a face shield while operating the gun. The operator's stance should be stable to enable this movement to be made without altering the critical positioning of the gun. Hold the gun firmly and close the circuit by squeezing the trigger. **KEEP THE TRIGGER DEPRESSED UNTIL THE BRAZE IS COMPLETE.**
- (7) After about 2 seconds, the fuse wire should rupture, disconnecting the circuit. The arc will extinguish and the pin or stud will be shot forward into the molten filler. *(In the event of a fuse not rupturing after the normal time, the gun must be withdrawn completely from the work, keeping the trigger depressed.)*
- (8) After the fuse has ruptured, the gun must be held in place for another 3 seconds to allow the braze to set.
- (9) Remove the gun by pulling it straight off of the pipe in line with the brazed pin, then break out the ferrule if there is some remaining in the ferrule holder.
- (10) Hold the gun in a vertical position then depress the ejector button to expel the remaining fuse wire. Ensure the wire has been completely ejected.

E. Testing a Completed Bond

- (1) Threaded pin attachments should be tested by a torque device. For an M8 pin, the torque device should be set to 10 Nm. The threads will fail at 25 Nm so do not use excessive force.
- (2) Direct braze pin attachments must be tested as follows: The shank of the plain pin must be carefully broken off with a hammer taking care not to damage the lug. This must be done before another pin braze is made to the bond. After breaking

UNCONTROLLED IF PRINTED

off the shank, the broken surface should be level or thereabouts with the outer surface of the lug.

F. Coating

Use an approved liquid coating or Viscotaq coating patch to coat the pin brazed and ground connection areas.

G. Pin Brazing Consumables

BRAZING PINS & Ferrules

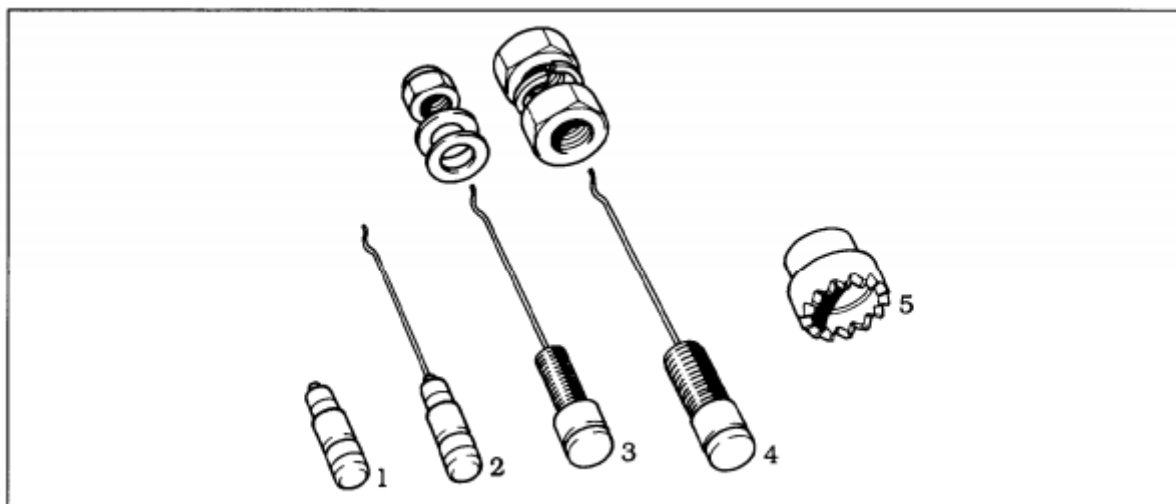

Pin Brazing Items					
Figure	Part No.	Description	Size	Package Size	Remarks
1	278 190 4320	Brazing Pin, F	8 mm	100	Without Fuse Wire
1	278 190 4360	Brazing Pin, Extra Solder B			
1	278 190 4350	Brazing Pin, G	9.5 mm	100	Without Fuse Wire
2	270 075 1210	Brazing Pin, Standard F	8 mm	100	With Fuse Wire
2	270 083 3520	Brazing Pin, Extra Solder B			
2	278 190 3250	Brazing Pin 610° C.P.			
2	270 075 1630	Brazing Pin, G	9.5 mm	100	With Fuse Wire
3	278 190 0430	Threaded Brazing Pin, F	M8/12 x 30 mm	50	With Fuse Wire
3	278 190 4920	Threaded Brazing Pin, F	M8/12 x 30 mm	50	Without Fuse Wire
3	278 190 3450	Threaded Brazing Pin, F	M10 x 34 mm	50	With Fuse Wire
3	278 190 4980	Threaded Brazing Pin, F	M10 x 34 mm	50	Without Fuse Wire
4	278 190 2560	Threaded Brazing Pin, F	M12 x 34 mm	25	With Fuse Wire
4	278 190 4930	Threaded Brazing Pin, F	M12 x 34 mm	25	Without Fuse Wire
5	270 077 3680	Ferrule	12 mm	100	

Consumables are available through:

Galvotec Corrosion Services, LLC

300 Bark Road, Bldg C-2

Harvey, LA 70058

Tel: 504-362-7373, Email: service@galvotec.com

6. *Welded Bolt Anode Wire or Test Lead Connections to Steel Pipe*

UNCONTROLLED IF PRINTED

A. This method shall only be used on steel pipe with MAOP of 100 psig or less.

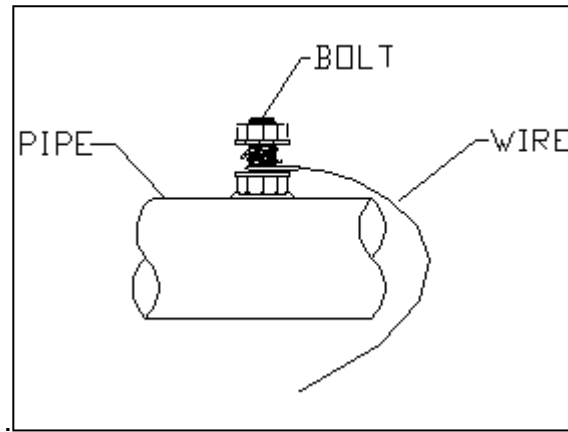

Welded Bolt Connection

B. Installation

- (1) Clean pipe thoroughly before welding bolt to pipe.
- (2) Weld one pass around the circumference of the 5/16 inch bolt head to the pipe.
- (3) Place washers on bolt and attach wire between washers. Use caution not to damage, flatten, kink, or nick the wire while removing the insulation.
- (4) Tighten the hex nut on the bolt to hold the wire securely in place.
- (5) See Test Lead Attachment Coating section for coating of connection.

C. Material List

Item	Stock No.	Description	Quantity
1	21 76 626	Bolt, Hex Head, 5/16" Dia. x 3/4" Long x 1/2" Head	1
2	21 61 408	Nut, Hex, 5/16"	1
3	23 66 187	Washer, Flat, 5/16"	2

7. Test Lead Attachment Coating

A. Hot Applied or Cold Applied Butyl 35 or H35 Tape

The following 4-step process should be utilized to wrap attached lead with hot applied or cold applied Butyl tapes. This process applies to attachments made with Cadweld thermite weld, Cadweld Plus, Pin Brazing or welded bolt.

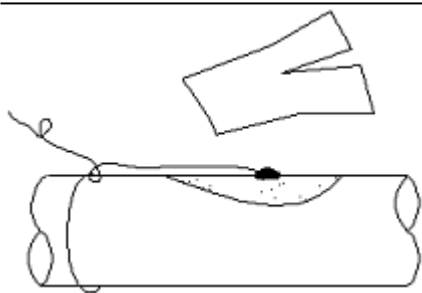

1. Apply primer.
2. Rip length of tape halfway through, heat (if hot applied) and slide under wire, and snug against connection.

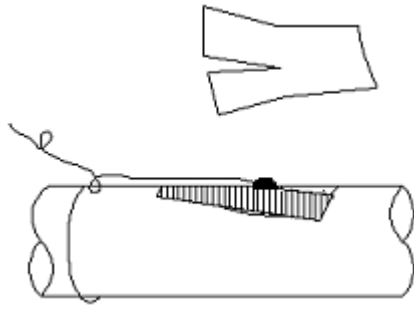

3. Rip second length of tape halfway through, heat (if hot applied) and slide to snug fit on opposite side of attachment.

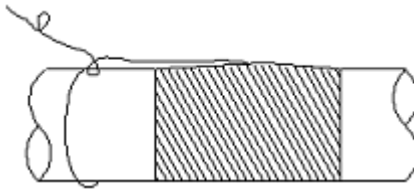

4. Spiral wrap over attachment area with tape, overlapping disturbed pipe coating about 2" (typical).

B. Viscotaq Coating Patch (30-10-165)

Viscotaq coating patch is used to seal test lead wire attachment connections on steel pipe. The Viscotaq patch is UV resistant.

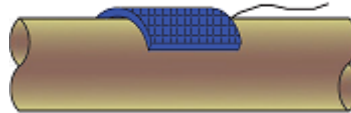

Viscotaq Coating Patch

(1) Installation

- (a) Clean the area to be coated with sandpaper supplied with the kit.
- (b) Wipe the area down with the wipe supplied in the kit to remove any grease, debris or moisture
- (c) Ensure the area to be coated is clean and dry.
- (d) Remove a small piece of the Viscotaq material and place it under the wire to ensure that the area between the wire and the pipe is sealed when the patch is applied.
- (e) Peel off the release liner.
- (f) Place the coating patch over the cleaned area, ensuring the connection and all of the bare pipe is covered.
- (g) Press the patch into place ensuring the entire underside of the patch is firmly adhered to the pipe.

Appendix C - Equipment

C-1. 4 Pin Meters



Nilsson and Tinker & Razor 4 Pin Meters

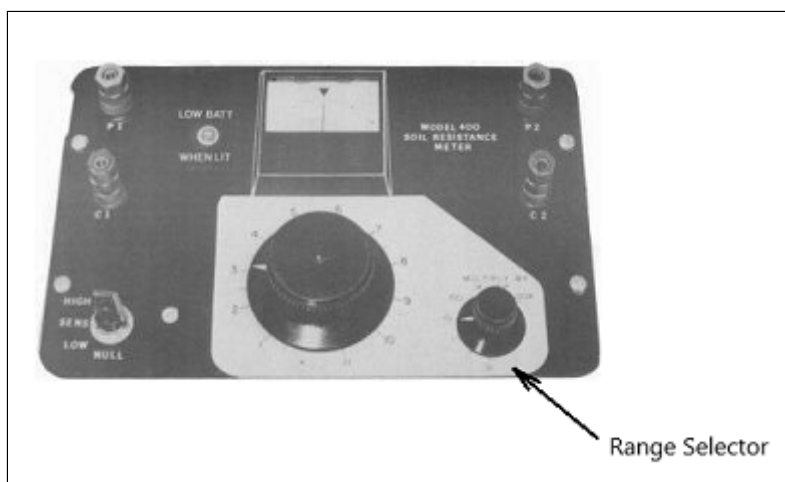

Nilsson 4 Pin Meter Panel

C-2. Single Pin Meter and Probe

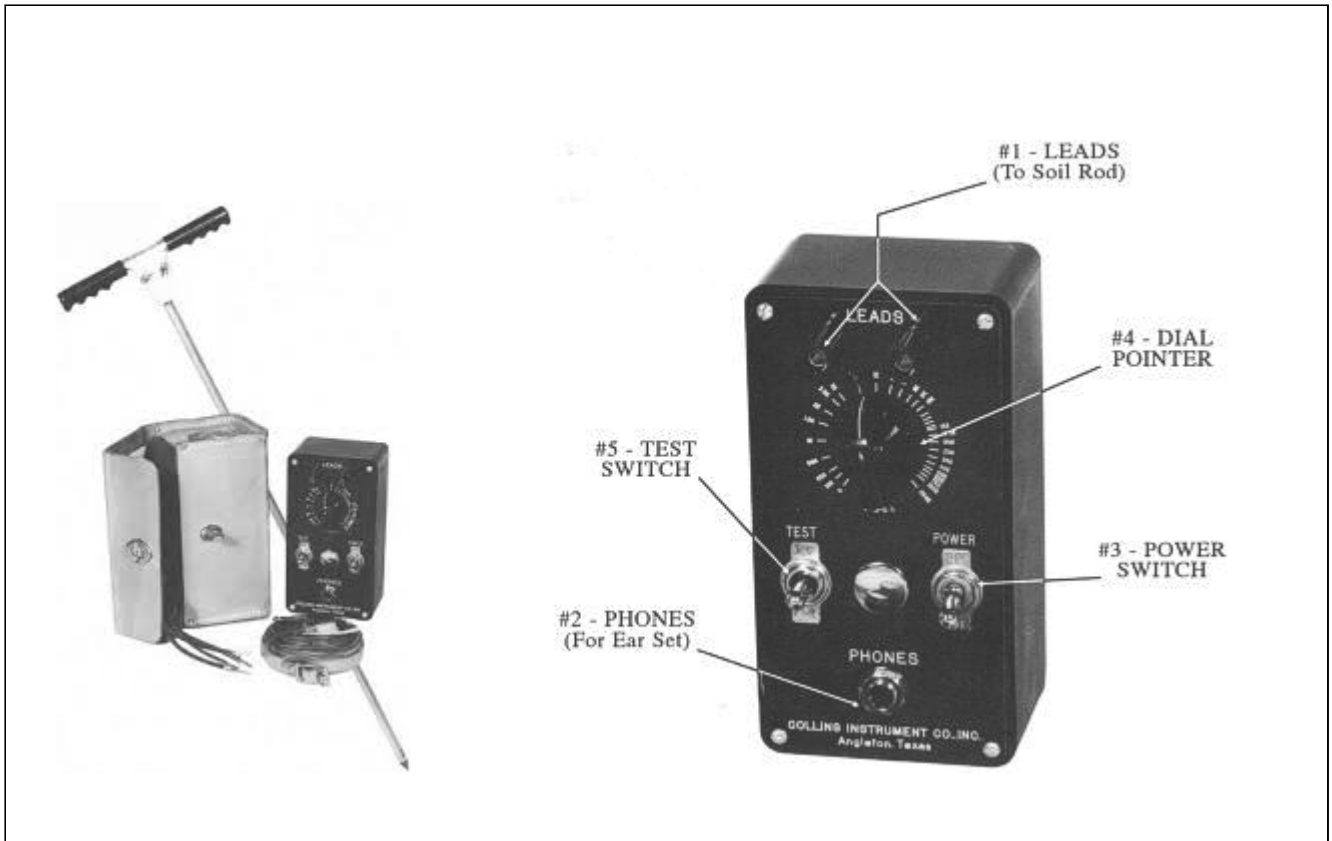

Collins Single probe meter

C-3. Soil Box



C-4. RF Insulation Tester



UNCONTROLLED IF PRINTED

CORROSION CONTROL

October 1, 2020

CORR 2.9 Evaluation of Corrosion

1.0 Purpose

The procedure provides instruction on how to evaluate corrosion pitting and resulting pipeline integrity. This document uses guidelines provided in ASME/ANSI B31G.

2.0 Scope

This document addresses the following:

[3.0 Target Audience](#)

[4.0 General](#)

[5.0 Distribution Piping \(60 psig and Below\)](#)

[6.0 Transmission or High Pressure Distribution Piping \(Over 60 psig\)](#)

[7.0 Allowable Pit Length Tables](#)

[8.0 Pipe Pit Gauge](#)

[9.0 Pipe Thickness Gauge](#)

Appendices:

[Appendix A - Flow Chart for Analytical Method](#)

[Appendix B - Maximum Allowable Pit Depth](#)

[Appendix C - Allowable Pit Length Tables](#)

3.0 Target Audience

- Gas Engineering
- Gas Tech Engineering
- Gas Integrity Management Personnel
- Gas Supervisors
- Gas Field Personnel
- Corrosion Control Supervisors
- Corrosion Control Specialists
- Gas Tech Services Supervisors
- Gas Tech Services Personnel
- Gas Storage Field Supervisors
- Gas Storage Field Operators
- Gas Construction Services Supervisors
- Gas Construction Inspectors

4.0 General

4.1 Measuring pipeline corrosion is an important task that requires careful attention to detail and following the appropriate process to ensure that the appropriate repair decision is made and documented.

5.0 Distribution Piping (60 psig and Below)

If corrosion has reduced the remaining wall thickness to less than required for the maximum allowable operating pressure or less than 30% of the nominal wall thickness, the corroded piping must

UNCONTROLLED IF PRINTED

be repaired or replaced. The maximum allowable pit depth on distribution piping is 70% of the original wall thickness.

5.1 Measuring Pitted Areas (Underground or Atmospheric Corrosion)

5.1.1 Wire brush corroded area to bare metal.

Use caution when cleaning corroded areas on active pipelines as severity of corrosion may not be apparent due to corrosion products remaining in pits.

5.1.2 Measure deepest pit or loss of pipe wall.

5.1.3 Compare pit depth to the maximum allowable pit depth indicated in [Appendix B-1](#).

5.1.4 Pit depths less than or equal to those in [Appendix B-1](#) require recoating only.

5.1.5 If pit depths exceed the allowable depths in [Appendix B-1](#), contact the Region Gas Engineer or Corrosion Control Tech for further evaluation and proper corrective action.

5.1.6 Document on Corrosion and Steel Damage Evaluation form within ClickMobile. Refer to [CORR 1 Appendix B](#).

6.0 Transmission or High Pressure Distribution Piping (Over 60 psig)

If corrosion has reduced the remaining wall thickness to less than required for the maximum allowable operating pressure or to less than 90% of the nominal wall thickness:

1. The corroded pipe must be repaired or replaced to restore the serviceability of the piping
or
2. The operating pressure reduced commensurate with the strength of the pipe based on actual remaining wall thickness.

6.1 The maximum allowable pit depth on Transmission and High-Pressure Distribution piping is 10% of the original wall thickness.

6.2 If corrosion has reduced the wall thickness by more than 10%, Corrosion Control shall be contacted before any corrective action is taken.

6.2.1 Corrosion Control along with Gas Tech Engineering will determine the appropriate corrective action to be taken.

6.3 Measuring Pitted Areas (Underground or Atmospheric Corrosion)

6.3.1 Wire brush corroded area to bare metal.

Use caution when cleaning corroded areas on active pipelines as severity of corrosion may not be apparent due to corrosion products remaining in pits.

- 6.3.2 Measure deepest pit or loss of pipe wall and measure length of each group of overlapping pits (see [Figure 1](#)).
- 6.3.3 Compare pit depth to the maximum allowable pit depth indicated in [Appendix B-2](#).

When using the Allowable Loss Tables, if the pipe wall thickness for the pipe diameter that is being assessed is not available, use the values for the next thinnest wall thickness in the table.

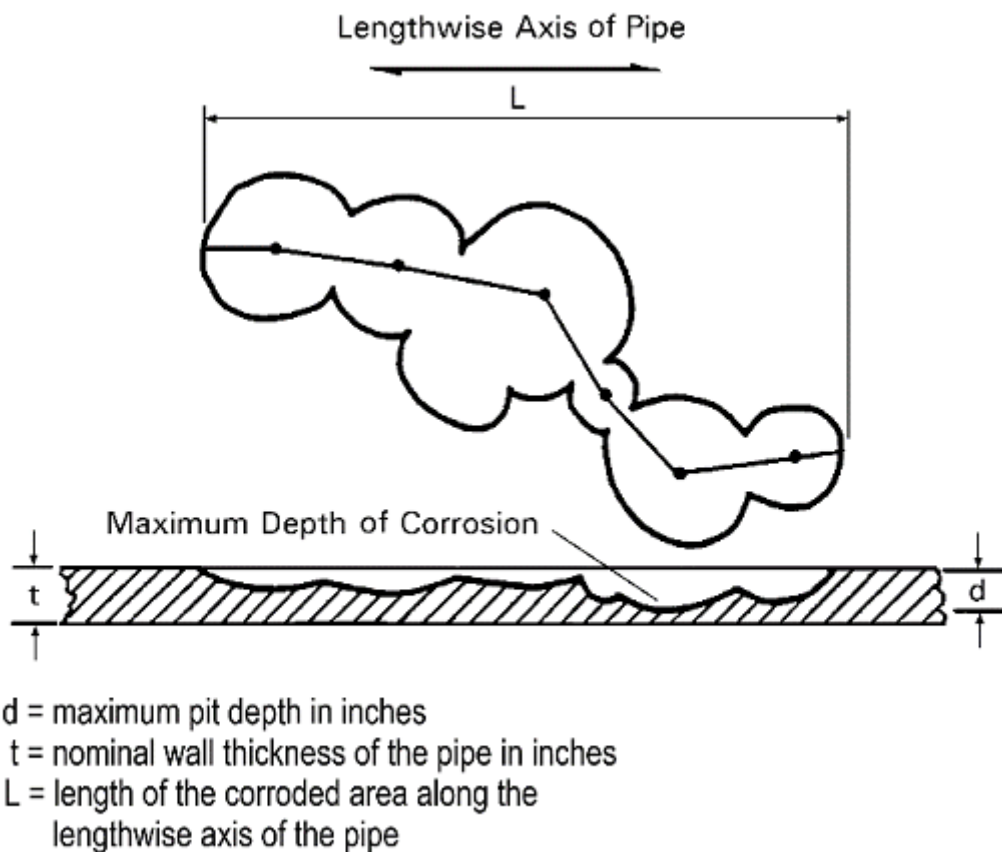

Figure 1 Pit Measurement Criteria

- 6.3.4 Pit depths less than or equal to those in [Appendix B-2](#) require recoating only.
- 6.3.5 If pit depths exceed the allowable depths in [Appendix B-2](#), contact Corrosion Control Tech or Gas Technical Services who will follow the Analytical Method Flowchart in [Appendix A](#) for further evaluation and proper corrective action.

Where the flowchart has contact Gas Technical Services this would include Corrosion Control personnel.

6.3.6 Document on Corrosion and Steel Damage Evaluation form within ClickMobile.

7.0 Allowable Pit Length Tables

7.1 See [Appendix C](#) for Allowable Pit Length Tables

7.2 Instructions

7.2.1 The tables in [Appendix C](#) are not valid for steel pipe with yield strength specifications less than 35,000 psig.

1. Contact Corrosion Control personnel for allowable pit lengths if pipe is less than 35,000 psig.
2. If the yield strength of the pipe is not known, allowable pit lengths should be based on a pipe with yield strength of 24,000 psig.

7.2.2 Select the table applicable to the pipe diameter to be analyzed.

7.2.3 Find the pit depth on the left hand side.

7.2.4 Follow the row over to the column with the appropriate wall thickness at the top. If the wall thickness is not in the table, use the next thinnest wall.

7.2.5 The length at the intersection of the row and column selected is the maximum length allowed for that pit depth.

7.2.6 If the actual pit length exceeds this value, a pipe strength calculation must be performed or the pipe must be repaired or replaced.

8.0 Pipe Pit Gauge

8.1 The Pipe Pit Gauge, Figure 2, is used to measure the depth of external pitting.

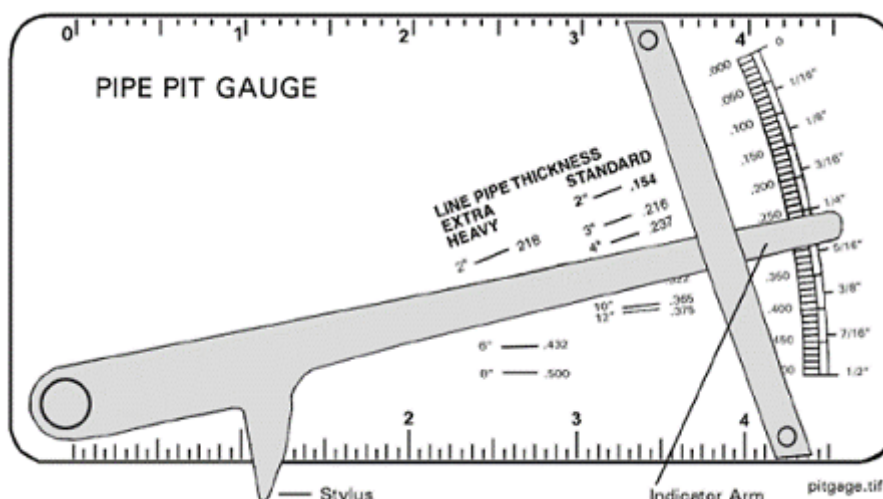

Figure 2 Pipe Pit Gauge (AG-1151, Stock Code 61 12 168)

8.2 Instructions

8.2.1 Clean adjoining pipe to bare metal.

8.2.2 Place gauge lengthwise on the pipe and align gauge with the center of the pipe.

UNCONTROLLED IF PRINTED

- 8.2.3 Push the arm down until the stylus touches the pipe.
- 8.2.4 Read the pit depth indicated by the top of the indicator arm.
- 8.2.5 Measure pitted area until deepest pit is found.
- 8.2.6 Measure length of pitted area by placing the gauge lengthwise on the pipe.
- 8.2.7 Record data on Corrosion and Steel Damage Evaluation form within ClickMobile.

9.0 Pipe Thickness Gauge

9.1 The Pipe Thickness Gauge, Figure 3, is used to measure the depth of internal pitting.

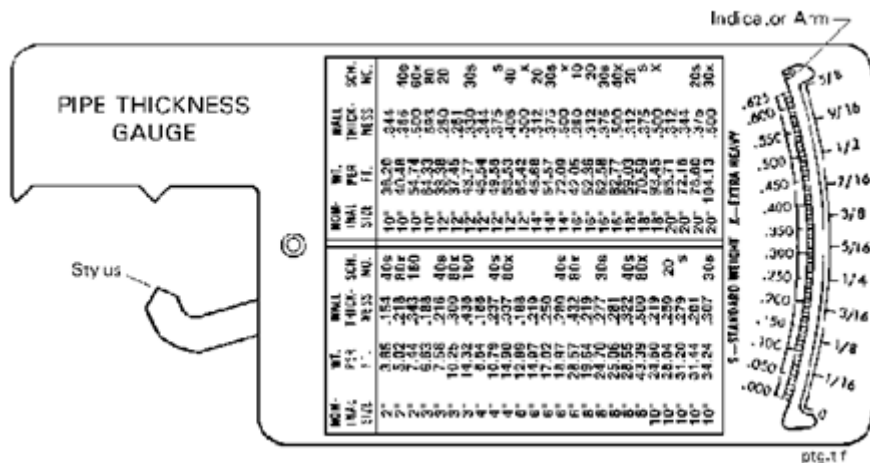

Figure 3 Pipe Thickness Gauge (AG-1153, Stock Code 85 20 170)

9.2 Instructions

- 9.2.1 Clean outside and inside of pipe to bare metal.
- 9.2.2 Cut pipe so thickness gauge can reach pitting.
- 9.2.3 Insert tool and move stylus until it touches the pipe.
- 9.2.4 Read the pipe thickness indicated by the top of the indicator arm.
- 9.2.5 Measure the area until the thinnest wall is found.
- 9.2.6 Record data on Corrosion and Steel Damage Evaluation form within ClickMobile. Refer to [CORR 1 Appendix B](#).

End of Instructions.

Operator Qualification (OQ) Required?

YES

- 0141: Visual Inspection of Atmospheric Corrosion
- 0151: Visual Inspection of Buried Pipe and Components when Exposed
- 0161: Visual Inspection for Internal Corrosion
- 0171: Measure External Corrosion
- 0181: Measure Internal Corrosion
- 0191: Measure Atmospheric Corrosion

UNCONTROLLED IF PRINTED

Appendices

[Appendix A - Flow Chart for Analytical Method](#)

[Appendix B - Maximum Allowable Pit Depth](#)

[Appendix C - Allowable Pit Length Tables](#)

Attachments

NONE.

Compliance Requirements

ASME B31G "Manual for Determining the Remaining Strength of Corroded Pipelines"

49 CFR §192.485 (c) Remedial measures: Transmission lines.

49 CFR §192.933 What actions must an operator take to address integrity issues?

Reference Documents

[CORR 1 Corrosion Control: Requirements](#)

Document Rescission

CORR 2.28 Corrosion Control: Evaluation of Corrosion, January 1, 2016.

Revision Notes

Location of Changes	Summary of Changes
Not applicable.	This is a new document.

Appendix A - Flow Chart for Analytical Method

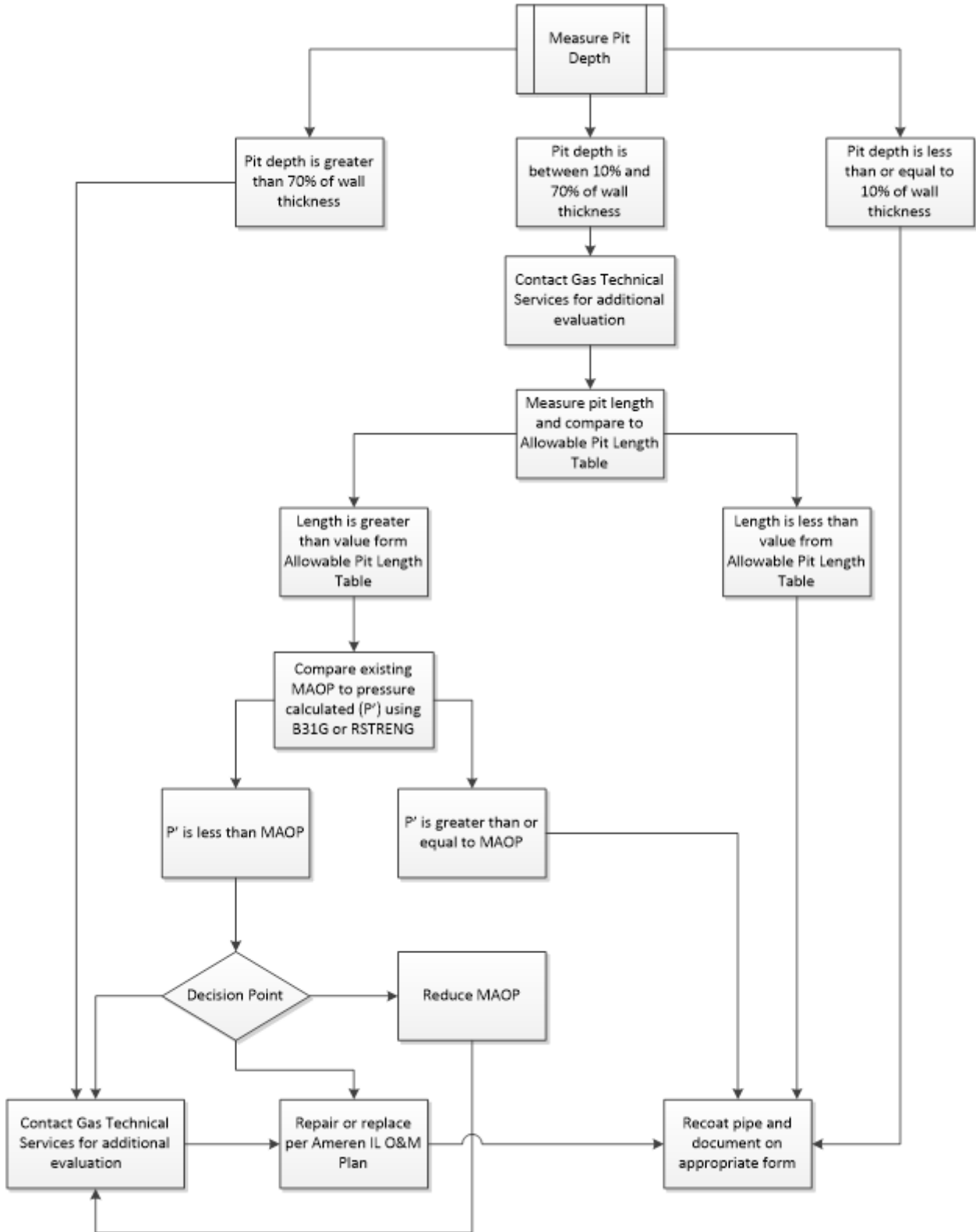

Appendix B - Maximum Allowable Pit Depth

B-1. Maximum Allowable Pit Depth on Distribution Piping (60 psig and Below)

Table 1 Maximum Allowable Pit Depth on Distribution Piping (60 psig and Below)		
Nominal Pipe Diameter	Nominal Wall Thickness (Standard Wall)	Maximum Allowable Pit Depth
3/4"	0.113"	0.079"
1-1/4"	0.140"	0.098"
2"	0.154"	0.107"

3"	0.156"	0.109"
4"	0.188"	0.131"
6"	0.219"	0.153"
8"-18"	0.250"	0.175"

B-2. Maximum Allowable Pit Depth on Transmission or High Pressure Distribution Piping (Over 60 psig)

Table 2 Maximum Allowable Pit Depth on Transmission or High Pressure Distribution Piping (Over 60 psig)		
Nominal Pipe Diameter	Nominal Wall Thickness (Standard Wall)	Maximum Allowable Pit Depth
3/4"	0.113"	0.011"
1-1/4"	0.140"	0.014"
2"	0.154"	0.015"
3"	0.156"	0.015"
4"	0.188"	0.018"
6"	0.219"	0.021"
8"-18"	0.250"	0.025"

Appendix C - Allowable Pit Length Tables

C-1. Values of L for Pipe 2.375" - 6.625" Diameter

Values of L for Pipe 2.375" – 6.625" Diameter								
Pit Depth (d)	Wall Thickness (t) for Pipe							
	0.083"	0.109"	0.125"	0.141"	0.154"	0.172"	0.188"	0.218"
0.010"	2"							
0.020"	15/16"	1-5/16"	2-7/16"	2-9/16"	2-11/16"	2-7/8"	3"	
0.030"	1/2"	7/8"	1-1/8"	1-1/2"	1-15/16"	2-7/8"	3"	3-1/4"
0.040"	3/8"	5/8"	3/4"	15/16"	1-1/8"	1-3/8"	1-3/4"	2-3/4"
0.050"	5/16"	7/16"	9/16"	11/16"	13/16"	1"	1-3/16"	1-1/16"
0.060"	1/4"	3/8"	1/2"	9/16"	11/16"	13/16"	15/16"	1-3/8"
0.070"		5/16"	7/16"	1/2"	9/16"	11/16"	3/4"	1"
0.080"		5/16"	5/8"	7/16"	1/2"	9/16"	11/16"	13/16"
0.090"			3/16"	3/8"	7/16"	1/2"	9/16"	3/4"
0.100"			1/4"	5/16"	3/8"	7/16"	1/2"	11/16"
0.110"				5/16"	3/8"	7/16"	1/2"	5/8"
0.120"					5/16"	3/8"	7/16"	9/16"
0.130"						5/16"	3/8"	1/2"
0.140"							3/8"	7/16"
0.150"							5/16"	7/16"
0.160"								3/8"
0.170"								3/8"

C-2. Values of L for Pipe 6.625" -10.750" Diameter

Values of L for Pipe 6.625" –10.750" Diameter								
Pit Depth (d)	Wall Thickness (t) for Pipe							
	0.083"	0.125"	0.156"	0.188"	0.203"	0.219"	0.250"	0.312"
0.010"	3-5/16"							
0.020"	1-1/2"	4-1/16"	4-9/16"	5"				
0.030"	7/8"	1-7/8"	3-3/8"	5"	5-3/16"	5-3/8"	5-3/4"	
0.040"	5/8"	1-1/4"	1-7/8"	2-15/16"	3-5/8"	4-5/8"	5-3/4"	6-7/16"
0.050"	1/2"	15/16"	1-3/8"	1-15/16"	2-5/16"	2-3/4"	3-7/8"	6-7/16"
0.060"	7/16"	13/16"	1-1/8"	1-9/16"	1-3/4"	2-1/16"	2-11/16"	4-3/4"
0.070"		11/16"	15/16"	1-5/16"	1-7/16"	1-11/16"	2-1/8"	3-3/8"
0.080"		9/16"	13/16"	1-1/8"	1-1/4"	1-7/16"	1-3/4"	2-11/16"
0.090"		1/2"	3/4"	1"	1-1/8"	1-1/4"	1-9/16"	2-1/4"
0.100"		7/16"	11/16"	7/8"	1"	1-1/8"	1-3/8"	2"
0.110"			9/16"	13/16"	7/8"	1"	1-1/4"	1-3/4"
0.120"			9/16"	3/4"	13/16"	15/16"	1-1/8"	1-5/8"
0.130"				11/16"	3/4"	7/8"	1-1/16"	1-7/16"
0.140"				5/8"	11/16"	13/16"	15/16"	1-3/8"
0.150"				9/16"	5/8"	3/4"	7/8"	1-1/4"
0.160"					9/16"	11/16"	13/16"	1-3/16"
0.170"						5/8"	3/4"	1-1/8"
0.180"							3/4"	1-1/16"
0.190"							11/16"	1"
0.200"							5/8"	15/16"
0.210"								7/8"
0.220"								13/16"
0.230"								13/16"
0.240"								3/4"

C-3. Values of L for Pipe 10.750" - 16" Diameter

Values of L for Pipe 10.750" – 16" Diameter								
Pit Depth (d)	Wall Thickness (t) for Pipe							
	0.156"	0.219"	0.250"	0.307"	0.344"	0.365"	0.438"	0.500"
0.020"	5-13/16"							
0.030"	4-5/16"	6-7/8"	7-3/8"					
0.040"	2-7/16"	5-15/16"	7-3/8"	8-1/8"	8-5/8"	8-7/8"		
0.050"	1-3/4"	3-1/2"	4-15/16"	8-1/8"	8-5/8"	8-7/8"	9-3/4"	10-3/8"
0.060"	1-7/16"	2-9/16"	3-3/8"	5-3/4"	8-5/8"	8-7/8"	9-3/4"	10-3/8"
0.070"	1-3/16"	2-1/8"	2-11/16"	4-1/8"	5-1/2"	6-5/8"	9-3/4"	10-3/8"
0.080"	1-1/16"	1-13/16"	2-1/4"	3-5/16"	4-3/16"	4-7/8"	8-3/8"	10-3/8"
0.090"	15/16"	1-9/16"	1-15/16"	2-13/16"	3-1/2"	3-15/16"	6-1/8"	9-3/8"
0.100"	13/16"	1-7/16"	1-3/4"	2-7/16"	3"	3-3/8"	4-15/16"	6-15/16"
0.110"	3/4"	1-3/16"	1-9/16"	2-3/16"	2-5/8"	2-15/16"	4-3/8"	5-5/8"
0.120"	11/16"	1-1/16"	1-7/16"	2"	2-3/8"	2-5/8"	3-11/16"	4-13/16"
0.130"		1"	1-5/16"	1-13/16"	2-3/16"	2-3/8"	3-5/16"	4-1/4"
0.140"		15/16"	1-1/4"	1-11/16"	2"	2-3/16"	3"	3-13/16"
0.150"		7/8"	1-1/8"	1-9/16"	1-7/8"	2-1/16"	2-3/4"	3-7/16"
0.160"		13/16"	1-1/16"	1-7/16"	1-3/4"	1-15/16"	2-9/16"	3-3/16"
0.170"		3/4"	1"	1-3/8"	1-5/8"	1-13/16"	2-3/8"	2-15/16"
0.180"			15/16"	1-5/16"	1-9/16"	1-11/16"	2-1/4"	2-3/4"
0.190"			7/8"	1-1/4"	1-7/16"	1-5/8"	2-1/8"	2-5/8"
0.200"			13/16"	1-1/8"	1-3/8"	1-1/2"	2"	2-7/16"
0.210"				1-1/8"	1-5/16"	1-7/16"	1-7/8"	2-5/16"
0.220"				1-1/16"	1-1/4"	1-3/8"	1-13/16"	2-1/4"
0.230"				1"	1-3/16"	1-5/16"	1-3/4"	2-1/8"
0.240"				15/16"	1-1/8"	1-1/4"	1-11/16"	2-1/16"
0.250"					1-1/16"	1-3/16"	1-9/16"	1-15/16"
0.260"					1-1/16"	1-1/8"	1-1/2"	1-7/8"
0.270"					1"	1-1/16"	1-7/16"	1-13/16"
0.280"						1-1/16"	1-7/16"	1-3/4"
0.290"						1"	1-3/8"	1-11/16"
0.300"							1-5/16"	1-5/8"
0.310"							1-1/4"	1-9/16"
0.320"							1-3/16"	1-1/2"
0.330"							1-3/16"	1-7/16"
0.340"							1-1/8"	1-3/8"
0.350"							1-1/16"	1-3/8"
0.360"								1-5/16"
0.370"								1-1/4"
0.380"								1-1/4"
0.390"								1-3/16"
0.400"								1-3/16"

C-4. Values of L for Pipe 16" - 20" Diameter

Values of L for Pipe 16" – 20" Diameter								
Pit Depth (d)	Wall Thickness (t) for Pipe							
	0.188"	0.250"	0.312"	0.344"	0.375"	0.438"	0.500"	0.625"
0.020°	7-3/4"							
0.030°	7-3/4"	8-15/16"						
0.040°	4-1/2"	8-15/16"	10"	10-1/2"	11"			
0.050°	3-1/16"	6"	10"	10-1/2"	11"	11-7/8"	12-11/16"	
0.060°	2-3/8"	4-1/8"	7-7/16"	10-1/2"	11"	11-7/8"	12-11/16"	
0.070°	2"	3-1/4"	5-1/4"	6-3/4"	8-13/16"	11-7/8"	12-11/16"	14-3/16"
0.080°	1-3/4"	2-3/4"	4-3/16"	5-1/8"	6-3/8"	10-3/16"	12-11/16"	14-3/16"
0.090°	1-1/2"	2-3/8"	3-1/2"	4-1/4"	5-1/16"	7-7/16"	11-7/16"	14-3/16"
0.100°	1-3/8"	2-1/8"	3-1/16"	3-5/8"	4-5/16"	6"	8-1/2"	14-3/16"
0.110°	1-1/4"	1-15/16"	2-3/4"	3-1/4"	3-3/4"	5-1/8"	6-7/8"	13-7/8"
0.120°	1-1/8"	1-3/4"	2-1/2"	2-15/16"	3-3/8"	4-1/2"	5-7/8"	10-9/16"
0.130°	1-1/16"	1-5/8"	2-1/4"	2-11/16"	3-1/16"	4"	5-3/16"	8-5/8"
0.140°	15/16"	1-1/2"	2-1/8"	2-7/16"	2-13/16"	3-5/8"	4-5/8"	7-7/16"
0.150°	7/8"	1-3/8"	1-15/16"	2-1/4"	2-5/8"	3-5/8"	4-1/4"	6-9/16"
0.160°		1-5/16"	1-13/16"	2-1/8"	2-7/16"	3-1/8"	3-7/8"	5-15/16"
0.170°		1-3/16"	1-11/16"	2"	2-1/4"	2-15/16"	3-5/8"	5-3/8"
0.180°		1-1/8"	1-5/8"	1-7/8"	2-1/8"	2-3/4"	3-3/8"	5"
0.190°		1-1/16"	1-1/2"	1-3/4"	2"	2-9/16"	3-3/16"	4-5/8"
0.200°		1"	1-7/16"	1-11/16"	1-15/16"	2-7/16"	3"	4-3/8"
0.210°			1-3/8"	1-5/8"	1-13/16"	2-5/16"	2-7/8"	4-1/8"
0.220°			1-5/16"	1-1/2"	1-3/4"	2-3/16"	2-11/16"	3-7/8"
0.230°			1-1/4"	1-7/16"	1-11/16"	2-1/8"	2-9/16"	3-11/16"
0.240°			1-3/16"	1-3/8"	1-9/16"	2"	2-1/2"	3-1/2"
0.250°				1-5/16"	1-1/2"	1-15/16"	2-3/8"	3-3/8"
0.260°				1-1/4"	1-7/16"	1-7/8"	2-1/4"	3-1/4"
0.270°				1-3/16"	1-3/8"	1-13/16"	2-3/16"	3-1/8"
0.280°					1-5/16"	1-11/16"	2-1/8"	3"
0.290°					1-5/16"	1-5/8"	2-1/16"	2-7/8"
0.300°					1-1/4"	1-9/16"	1-15/16"	2-3/4"
0.310°						1-9/16"	1-7/8"	2-11/16"
0.320°						1-1/2"	1-13/16"	2-9/16"
0.330°						1-7/16"	1-3/4"	2-1/2"
0.340°						1-3/8"	1-11/16"	2-7/16"
0.350°						1-5/16"	1-11/16"	2-3/8"
0.360°							1-5/8"	2-5/16"
0.370°							1-9/16"	2-1/4"
0.380°							1-1/2"	2-3/16"
0.390°							1-7/16"	2-1/8"
0.400°							1-7/16"	2-1/16"
0.410°								2"
0.420°								1-15/16"
0.430°								1-7/8"
0.440°								1-7/8"
0.450°								1-13/16"
0.460°								1-3/4"
0.470°								1-11/16"
0.480°								1-11/16"
0.490°								1-5/8"
0.500°								1-9/16"

UNCONTROLLED IF PRINTED

CORROSION CONTROL

October 1, 2022

CORR 2.10 Rectifier Maintenance and Troubleshooting

1.0 Purpose

The purpose of this document is to provide guidance in maintaining and troubleshooting cathodic protection rectifiers. Instructions on installing rectifiers are also included in the document.

2.0 Scope

This document addresses the following:

[3.0 Target Audience](#)

[4.0 Rectifier Installation](#)

[5.0 Rectifier Maintenance](#)

[6.0 Rectifier Troubleshooting](#)

Appendices:

[Appendix A - Rectifier Installation](#)

3.0 Target Audience

- Gas Tech Engineering
- Corrosion Control Supervisors
- Corrosion Control Specialists

4.0 Rectifier Installation

4.1 See [Appendix A](#) for rectifier installation instructions.

5.0 Rectifier Maintenance

5.1 General

5.1.1 Rectifiers require little periodic maintenance, but there are some maintenance checks that should be performed annually.

5.2 Rectifier Definition

5.2.1 A rectifier changes the AC to DC by inverting alternate halves of the AC waveform, making all portions electrically unidirectional.

5.2.2 Types of rectifiers

1. Selenium & Silicon
2. Air cooled/Oil cooled
3. Half wave/Full wave
4. Single phase/Three phase
5. Automatic adjustment/Manual adjustment.

5.3 Rectifier Safety

UNCONTROLLED IF PRINTED

- 5.3.1 Never approach a rectifier or electrical equipment until observing the surroundings.
- 5.3.2 Do a visual check of any loose wires on or around the service pole.
- 5.3.3 Do a visual check of any line fuses / transformers feeding the service pole. Note anything unusual.
- 5.3.4 Approach rectifier with proper safety equipment.
 - 1. Voltage tester to test rectifier cabinet/components
 - 2. Gloves
 - 3. Safety glasses
 - 4. Proper protective head gear
- 5.4 General Maintenance Instructions for Most Rectifiers
 - 5.4.1 Voltage, current and ambient temperature ratings of unit should not exceed specifications.
 - 5.4.2 Cleanliness inside and outside of rectifier should be maintained.
 - 5.4.3 Adequate ventilation must be maintained. All air vents and screens should not be obstructed. Remove all rodent, insect and bird nests from inside and around rectifier.
 - 5.4.4 Check the casing ground (ensure that rectifier case and all associated components are grounded correctly).
 - 5.4.5 Turn AC power off and check all electrical connections.
 - 5.4.6 Check for heat dispersion or burn marks on selenium rectifier stacks.
 - 5.4.7 An indication of excessive heat or burn marks is a precursor to rectifier failure.
 - 5.4.8 Oil cooled rectifiers should be free of any obstructions. Change the oil or replace with an air-cooled unit if the oil is contaminated.
 - 5.4.9 Check for hot fuses, breakers, (loose or under/oversized fuses).
 - 5.4.10 Verify rectifier readings/calibration settings.
 - 5.4.11 Ensure that rectifier is properly secured.
- 5.5 Rectifier Testing
 - 5.5.1 Required measurements
 - 1. DC Volts
 - 2. DC Amps
 - 5.5.2 Optional measurements
 - 1. Pipe to soil. Always place the half cell directly over the pipe.
 - 2. Electric meter reading
 - 3. Efficiency (calculated and usually of limited value for low output units below 30 or 40 amps)
- 5.6 Testing Procedures
 - 5.6.1 Test the case for AC voltage with a voltage indicator

UNCONTROLLED IF PRINTED

- 5.6.2 If voltage is indicated turn power off to the rectifier
- 5.6.3 If no voltage is indicated open the door of the unit
- 5.6.4 Check the volt meter and the ammeter for readings
- 5.6.5 Verify the volt reading using a portable multimeter
 - 1. Connect the positive lead to the positive output terminal
 - 2. Connect the negative lead to the negative output terminal
 - 3. Set the multimeter to DC Volts
 - 4. Observe and record the reading
- 5.6.6 Verify the ammeter reading using a portable multimeter
 - 1. Connect the positive lead to one side of the shunt
 - 2. Connect the negative lead to the other side of the shunt
 - 3. Set the multimeter to DC mV
 - 4. Observe and record the reading
 - 5. Locate the amp rating for the shunt
 - 6. Calculate the current output
 - 6 a. $\text{Current Output (Amps)} = \text{mV reading/mV rating} \times \text{shunt Amp rating}$
- 5.6.7 Visually check inside the case for debris that could block airflow, wires with missing insulation, scorch or burn marks, loose connections

6.0 Rectifier Troubleshooting

6.1 General

- 6.1.1 To troubleshoot a rectifier and return it to operation.

6.2 Rectifier Safety

- 6.2.1 Never approach a rectifier or electrical equipment until observing the surroundings.
- 6.2.2 Do a visual check of any loose wires on or around the service pole.
- 6.2.3 Do a visual check of any line fuses/transformers feeding the service pole. Note anything unusual.
- 6.2.4 Approach rectifier with proper safety equipment.
 - 1. Voltage tester to test rectifier cabinet/components
 - 2. Gloves
 - 3. Safety glasses
 - 4. Proper protective head gear

6.3 Rectifier Components

- 6.3.1 Cabinet -protects the rectifier components from the elements
- 6.3.2 Circuit Breaker -serves as an on-off switch and overload protection
- 6.3.3 Transformer -reduces the line voltage to a useable level for the cathodic protection system and isolates the CP system from the incoming power

UNCONTROLLED IF PRINTED

- 6.3.4 Rectifier Stack to change A.C. to D.C. (Silicon) or (Selenium)
- 6.3.5 Fuses to protect the more expensive components (like Diodes, ACSS, etc.)
- 6.3.6 Meters to indicate D.C. Voltage and D.C. Current
- 6.3.7 Shunts to accurately measure circuit current
- 6.3.8 Arrestors to protect the rectifier from voltage and lightning surges

6.4 Troubleshooting Basics

6.4.1 An adequate inspection and maintenance program will greatly reduce the possibility of rectifier failure. Rectifier failures do occur, however, and the field technician must know how to find and repair troubles quickly to reduce rectifier down time.

6.4.2 Major causes of rectifier failures:

1. Neglect
2. Age
3. Lightning

6.5 Troubleshooting Precautions

6.5.1 Turn the RECTIFIER and the MAIN DISCONNECT OFF

6.5.2 Be careful when testing a rectifier which is in operation. Safety first!

6.5.3 Consult the rectifier wiring diagram before troubleshooting

6.5.4 Correct polarity must be observed when using DC instruments

6.5.5 Rectifier should be in the OFF position before using an OHMMETER

6.6 Troubleshooting Procedures

6.6.1 Most rectifier troubles are simple and do not require extensive detailed troubleshooting procedures. It is usually better to systematically isolate the rectifier components until the defective part is found. The most common problems are:

1. Faulty meters
2. Loose terminals
3. Blown Fuses
4. Open ground bed leads
5. Lightning damage

6.6.2 Troubleshooting Procedures. See [Figure 1](#) "Typical Rectifier Circuit" for reference testing points.

1. Rubber gloves rated for 600 V are required to test live circuits over 50V.
2. Voltages inside the rectifier cabinet on some components exceed 50V.
3. Test the AC voltage across line side of the rectifier circuit breaker. (Points A - A)
4. Test the AC voltage across load side of the rectifier circuit breaker. This voltage should be the same as the line side. (Points B - B)
5. If no voltage is present at the breaker, check for voltage in the disconnect box.

UNCONTROLLED IF PRINTED

6. If there is no voltage at the line side disconnect, call the power supplier.
7. If there is no voltage on the load side of the disconnect, check fuses or breakers.
8. Check the input change taps for loose connections. Clean bars and nuts until bright before re-installing. (Point C)
9. Adjust for the correct input voltage.
10. Test the transformer secondary tap link bars for the presence of voltage. Voltage should be measured between the center taps of the high and low taps. (Points D - E)
11. If the circuit breaker trips, indicating a short circuit, the transformer can be isolated by removing the link bars. If the circuit breaker continues to trip, the transformer is shorted. If the circuit breaker holds, the short is not in the transformer.
12. If the circuit breaker trips after checking the transformer, isolate the stack by removing the DC leads. (Points H and J)
13. If the circuit breaker continues to trip when the DC leads on the stack are removed, a short circuit is probably in the stack.
14. If the circuit breaker does not trip when the DC leads on the stack are removed, but does when the leads are connected, a short circuit is probably the external ground-bed or structure leads.
15. Test the AC voltage supplied to the rectifier stack. This voltage should be the same as the voltage measured across the taps. (Points F - G)
16. If AC voltage is supplied to the stack, check the DC output voltage. If DC voltage is present but is less than expected, stack may have an open circuit and is half-waving. (Points H - J)
17. If DC voltage is present at the stack, but not at the rectifier output check for loose connections or open leads. (Points J - L and J - K)
18. Meters may cause the rectifier to appear defective. Check meter with portable meters known to be accurate.
19. If DC voltage is present at the rectifier output terminals, but no current is flowing, there is an open in one of the external DC leads.
20. Turn rectifier off and check by connecting positive output terminal to a temporary ground. If current output is present when the rectifier is re-energized, there is an open on the positive cable.
21. Lightning arrestors in rectifier may be isolated by removing them from the circuit.
22. If it is suspected that the choke is defective, it may be effectively taken from the circuit by placing a heavy jumper lead across the chock leads.

6.7 Troubleshooting More Difficult Problems

- 6.7.1 When troubleshooting more difficult problems it is usually better to systematically isolate the rectifier components until the defective part is found.

6.8 Troubleshooting Tips

- 6.8.1 Many rectifier problems are relatively obvious to the experienced technicians upon physical examination. The obvious should never be overlooked. Loose connections, signs of arcing, strange odors, etc., indicate troubles, which do not require elaborate test procedure to uncover.
- 6.8.2 Helpful Troubleshooting Tips to Follow:
1. No output voltage or current present.
 - 1 a. Breaker tripped (or fuse blown)
 - (i) ~Steady overload, reduce output slightly.
 - (ii) Short circuit in some component.
 - 1 b. No AC line voltage
 - 1 c. Open circuit
 - (i) Check all connections
 - (ii) Check all diodes in silicon stacks
 - 1 d. Defective meters or meter switches
 - 1 e. Defective transformer, good primary input, but no secondary output.
 - (i) Secondary probably open.
 - (ii) Check DC resistance of windings with an ohmmeter.
 - a. Secondary should have less than 1 Ω resistance.
 - b. Primary should have 1-10 Ω resistance
 - c. An open circuit is possible if resistance is extremely high.
 - 1 f. Circuit Breaker (or thermal overload protectors). If contacts do not close, repair or replace breaker.
 2. If maximum DC output amps at rated DC volts is half output.
 - 2 a. Check for proper AC input voltage.
 - 2 b. Check stacks for plates open circuit, this would make unit operate as a half-wave rectifier.
 - 2 c. Badly aged stacks.
 - 2 d. For 3-phase rectifiers in addition to the above single-phase rectifiers.
 - (i) Open circuit if, one AC line is considerably less than the other two.
 - (ii) One of three stacks is more aged than the other two.
 - 2 e. Low line voltage.
 3. Variable Transformer Control
 - 3 a. Some rectifiers may be equipped with a variable transformer in lieu of the standard tap and link bar arrangement. The variable transformer will provide step-less, infinite control of the output of the rectifier.
 - 3 b. (Troubleshooting the variable transformer will be the same as the procedure for the main transformer.
 - (i) AC input voltage should be checked across terminals one and four.

UNCONTROLLED IF PRINTED

- (ii) Output AC voltage can be checked across terminals one and three. (Control knob should be at maximum rotation.)
- (iii) Output voltage should be the same as input voltage.
- (iv) If no AC voltage is present on the output terminals of the variable transformer, check for open winding, dirty or worn wiper brush.

6.9 Typical Rectifier Circuit

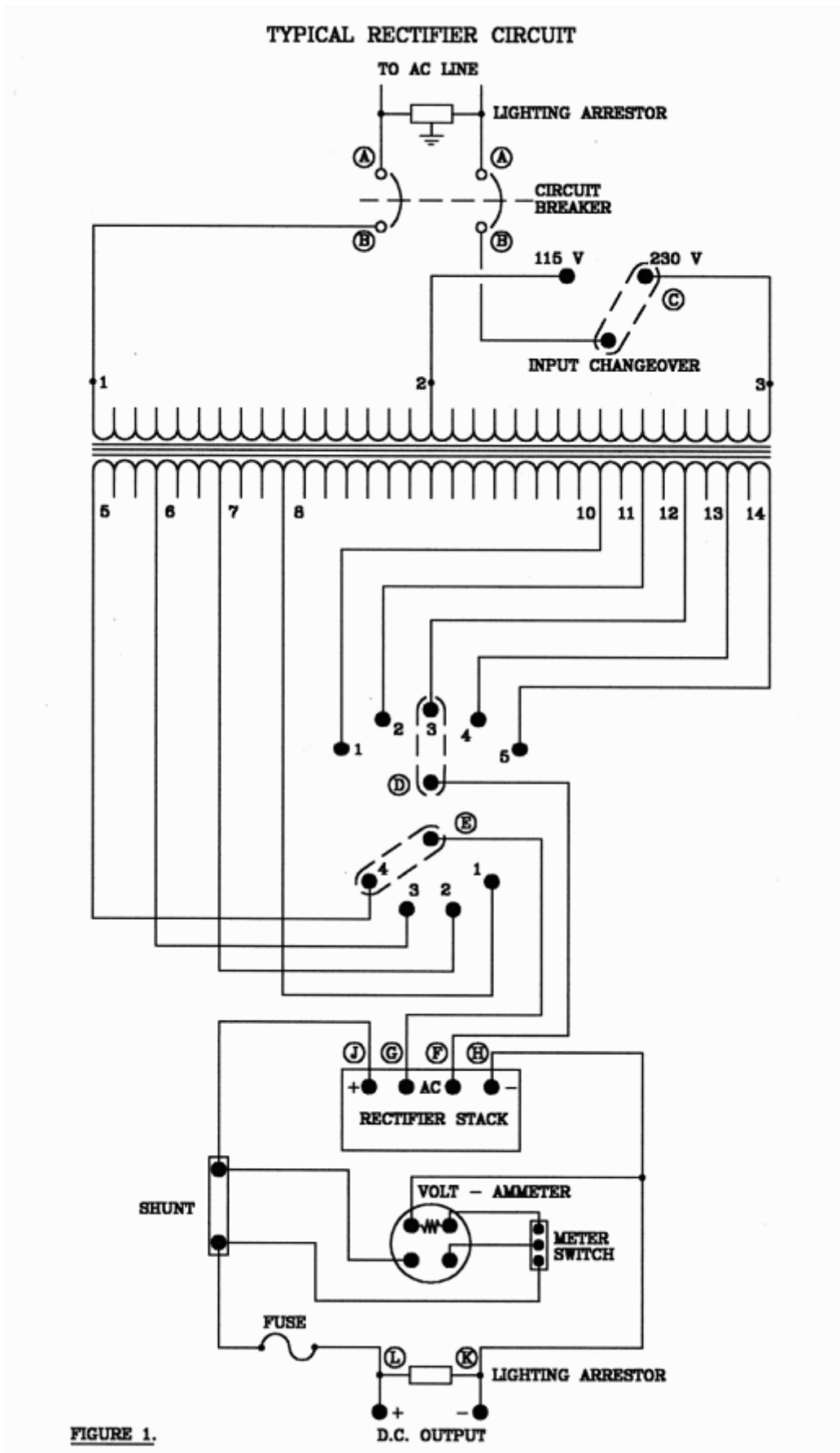

Figure 1 Typical Rectifier Circuit

6.10 Another Rectifier Circuit Diagram

UNCONTROLLED IF PRINTED

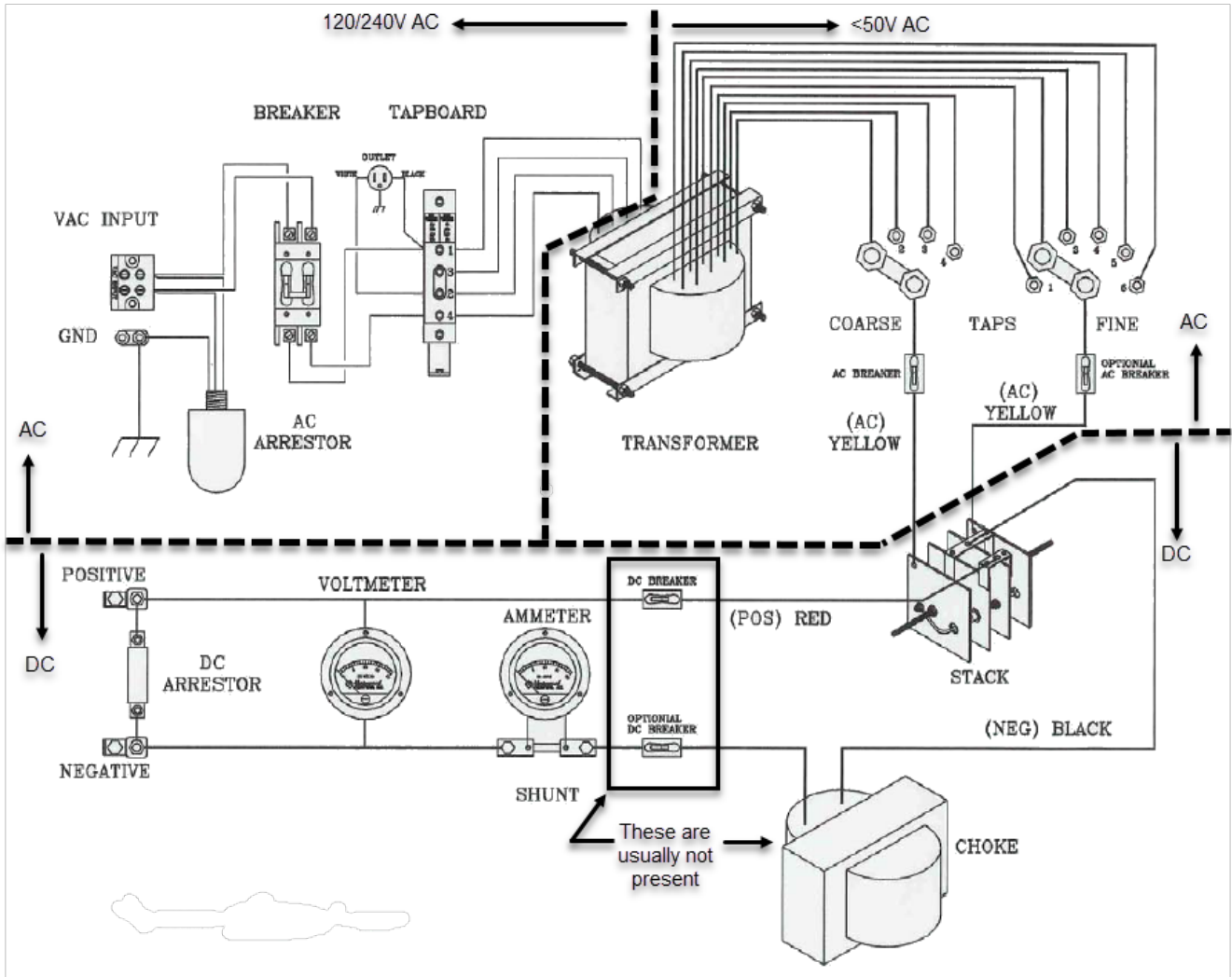

Figure 2 Rectifier Circuit Diagram

End of Instructions.

Operator Qualification (OQ) Required?

YES

0101: Inspect Rectifier and Obtain Readings

0111: Maintain Rectifier

Appendices

[Appendix A - Rectifier Installation](#)

Attachments

NONE.

Compliance Requirements

NONE.

Reference Documents

NONE.

Document Rescission

UNCONTROLLED IF PRINTED

CORR 2.10 Corrosion Control: Rectifier Maintenance and Troubleshooting, October 1, 2020

Location of Changes	Summary of Changes
Appendix A – Rectifier Installation, 3.3 Material List	Anode Splice Box, Dryconn VisiLock with Smart Gel, 4922428, replaced #90-B-1 Epoxy Spice Kit
Appendix A – 4.1.1 Rectifier Ground Bed Header Lead Connection	Grammatical - The Dryconn splice box does not have shelf life or temperature restraints whereas the 3M A Scotchcast Resin Kit does.

Appendix A - Rectifier Installation

1.0 General

1.1 Rectifier and anode bed installations should be designed by Gas Operations Support personnel with the training or experience to design impressed current cathodic protection systems.

2.0 Typical Rectifier and Ground Bed Layout

2.1 Detail

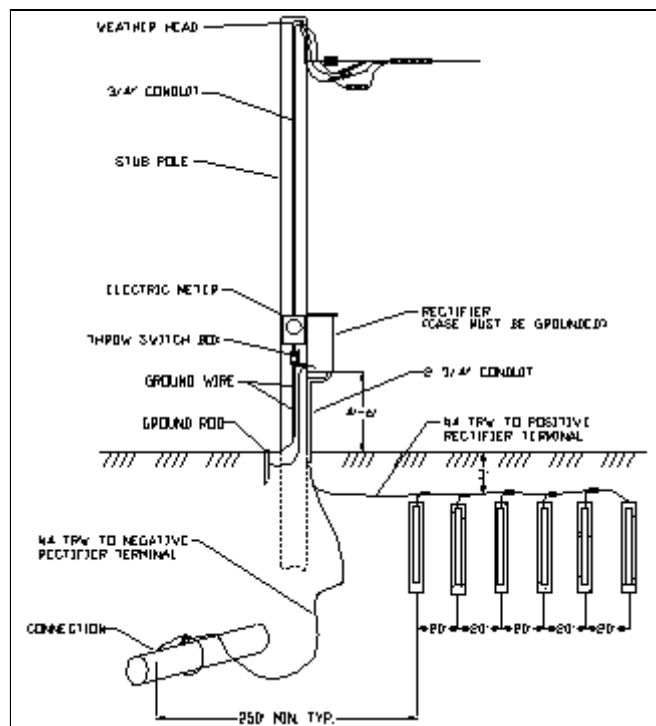

The number of anodes varies from installation to installation.

2.2 Installation

2.2.1 A 20 feet x 500 feet easement is typically required for the rectifier installation.

UNCONTROLLED IF PRINTED

2.2.2 Corrosion Control personnel designing the rectifier installation will determine and specify anode spacing and installation methods.

3.0 Rectifier Ground Bed Anode Installation

3.1 Detail

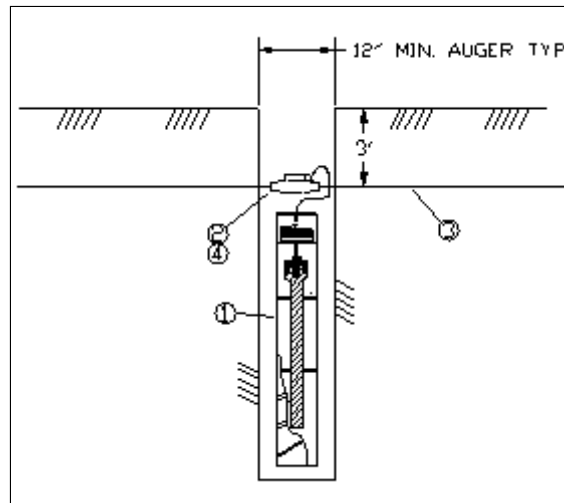

Note: Overall canister length is 7 feet

3.2 Installation

3.2.1 Do not use wire lead to lower anode.

3.2.2 Backfill anode with clean backfill and tamp firmly. Loose coke breeze is an optional backfill material

3.2.3 Recommended depth of hole is a minimum of 10 feet.

3.2.4 Recommended cable depth is 3 feet.

3.3 Material List

Item	Stock No.	Description	Quantity
			01
1	49 22 404	Anode, 3" x 60", Silicon iron Packaged with coke breeze, total length of package is 84" (7 feet)	1
2	49 22 428	Anode Splice Box, Dryconn Vislock with Smart Gel	1
3	49 22 405	Conductor, #4, Stranded, 600V, CU	1
4	17 54 373	Connector, Electrical, Split Bolt, 2 AWG Stranded, 4 CWC	1

4.0 Rectifier Ground Bed Header Lead Connection

4.1 Each anode lead wire connection in a rectifier anode ground bed shall be protected with a Dryconn VisiLock with Smart Gel Anode Splice Box or Anode Splice Box 3M A Scotchcast Resin Kit (90-B1).

4.1.1 The Dryconn splice box does not have a shelf life or temperature restraints where as the 3M A Scotchcast Resin Kit does

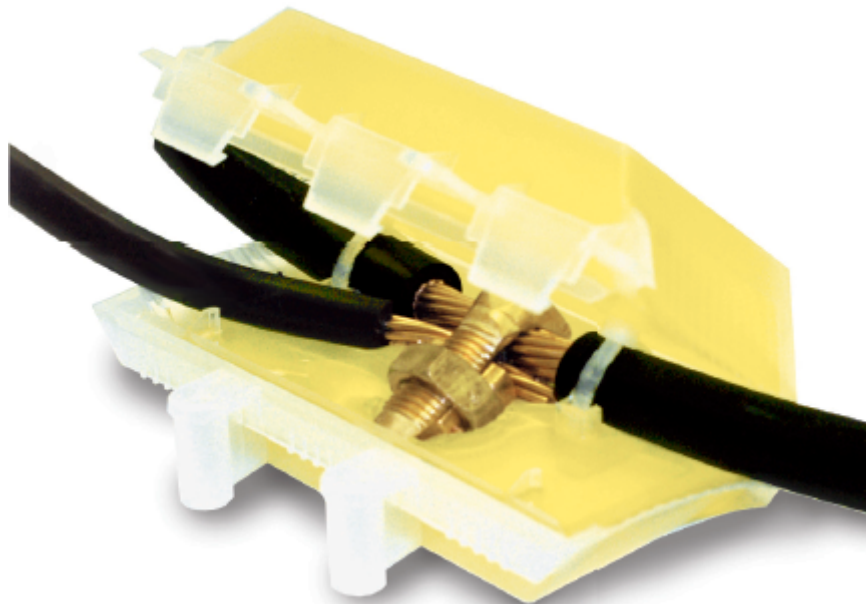

Dryconn VisiLock with Smart Gel Anode Splice Box

Stock Code 49 22 428

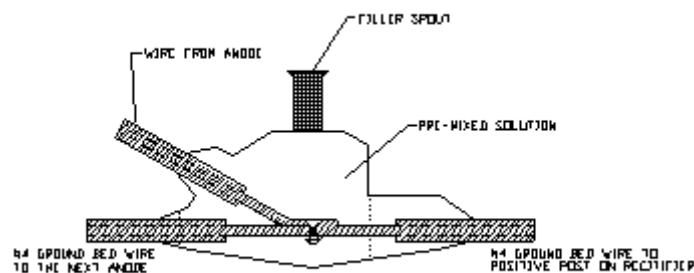

Anode Splice Box 3M A Scotchcast Resin Kit (90-B1)

Stock Code 62 55 100

4.1.2 General

1. Install the ground bed for a rectifier, as shown in Section 2. Splice the Dur-iron anodes with 6 feet of #8 7-strand cable to the #4 7-strand CP cable. Attachment is made with a split-bolt connector. Insulate and protect with a Dryconn VisiLock with Smart Gel Anode Splice Box or 3M's Scotchcast resin splicing kit.

4.2 Description

- 4.2.1 Dryconn VisiLock with Smart Gel is a one piece waterproof and corrosion proof box that contains a Smart Gel.
 1. Box is pre-filled with a non-toxic gel
 2. Box is re-enterable, semi-transparent, encapsulated splice box allows for visible splice examination
 3. Locking mechanism centers splice in box
 4. No shelf life with Smart Gel
 5. Designed to protect cathodic splices from corrosion

UNCONTROLLED IF PRINTED

6. Used to make tap or branch splices on insulated cables rated up to 100v
- 4.2.2 3M's Scotchcast resin splicing kit contains the material required to make the splice, except the split-bolt connector (17-54-373). The kit includes:
1. Two-piece snap together mold body
 2. Tape for sealing the ends
 3. Funnel
 4. Insulating and sealing compound (Scotchcast Brand 4 Resin) in Unipak container.

Note: This kit will accommodate the following connector and conductor sizes.

3M Scotchcast Resin Splice Kit (60-3500)			
Kit No.	Cable OD	Conductor Size	Sheath Opening
90-B1	Feeder Cable 1/2" to 13/16"	Split bolt 1/0 AWG (max.)	3" (max.)
	Branch Cable 3/8" (max.)	Crimped 2/0 AWG (max.)	

90-b1.tbl

4.3 Instructions

4.3.1 Dryconn VisiLock with Smart Gel Anode Splice Box

1. Install electrical connection per connector manufacturer's instructions
2. Lay main conductor into conductor cradles centering electrical connector as shown in Figure A
3. Position tap conductor in the box as shown in Figure A., Tap conductor be positioned to exit either side of housing.
4. Install wire ties tightly around the main conductor. Cut remaining length of wire tie and discard.
5. Close housing verifying it is securely latched.

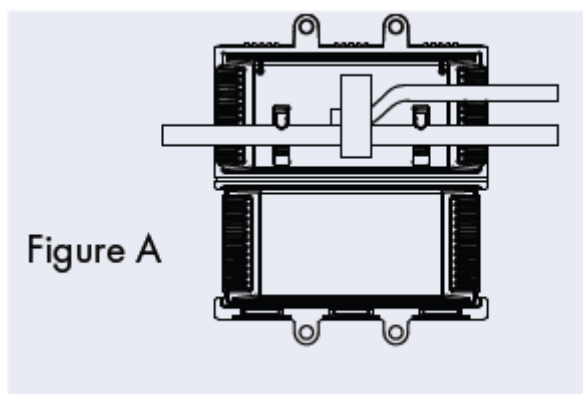

Figure A

4.3.2 3M's Scotchcast resin splicing kit

1. Prepare cable ends by removing insulation required for connector used.
2. Scrape insulation 5 inches back, adjacent to connection, to remove all wax and dirt.
3. Snap the transparent mold bodies over the splice.
4. Insert funnel in upright position.

UNCONTROLLED IF PRINTED

5. Seal ends with tape to form a resin-tight envelope. An extra wrap of electrical tape to hold the mold is recommended.
6. Squeeze the Unipak container to mix resin thoroughly. The resin mix pours best when temperature is 60°F to 90°F. On colder days, keep the kits in truck cab.
7. Open the pack and pour resin until mold and funnel are completely filled. Re-fill funnel after air escapes.
8. Note: Curing time for the resin is approximately 30 minutes. Resin may be kept in truck cab or in a sunny location to get a faster cure in cold weather.
9. Place cable in ditch after resin has cured. Time can be saved if splices are made in the ditch.
10. Backfill the ditch.

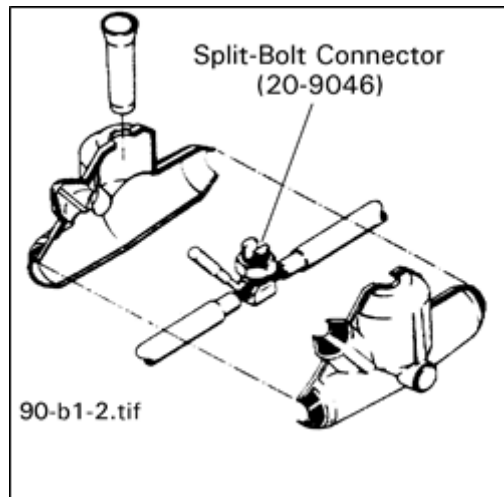

Figure 1 - Top Pour

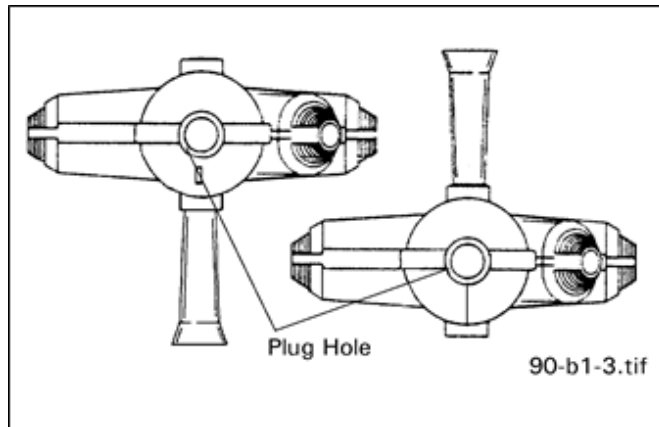

Figure 2 - Side Pour

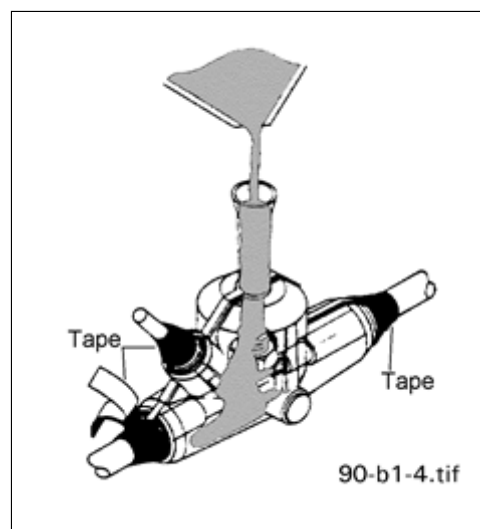

Figure 3

Note: The preferred pouring position is from the top as shown in Figures 1 and 3. If necessary, the kit can be poured from either side. Cut thin membrane from boss at

top of desired pouring position. Insert pouring spout and plug remaining hole with small plastic plug provided in kit. (See [Figure 2.](#))

5.0 Connection of Rectifier Lead to Transmission Main

5.1 Detail

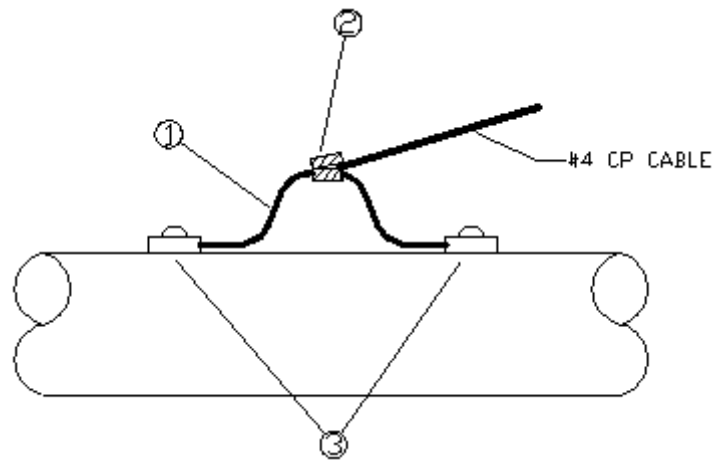

5.2 Installation

- 5.2.1 Do not attach wire within 2 inches of nearest girth weld.
- 5.2.2 The connection should be at least 6 inches apart.
- 5.2.3 Leave sufficient slack in wire to avoid damage by backfilling.
- 5.2.4 Attach wire to pipe with #15 thermite weld.
- 5.2.5 Coat each connection according to the methods described in [CORR 2.8 Appendix B.](#)

5.3 Material List

Item	Stock No.	Description	Quantity
			02
1	18 66 624	#8 Stranded Copper	X
2	62 55 100	Epoxy Splice Kit	1
3	22 02 552	Thermite Cad Weld	2

CORROSION CONTROL

October 1, 2021

CORR 2.11 Records

1.0 Purpose

This section provides instructions on how construction orders are to be reviewed by an individual qualified in corrosion control both during the design and following construction.

Instructions are provided for furnishing detail test point information, and performing other cathodic protection record activities.

2.0 Scope

This document addresses the following:

[3.0 Target Audience](#)

[4.0 Construction Order Review Processes](#)

[5.0 Additional Detail Information for Test Points](#)

[6.0 Other Cathodic Protection Record Activities](#)

Appendices:

[Appendix A - Cathodic Protection Review Responsibility Table](#)

[Appendix B - Cathodic Protection Review Stamp](#)

[Appendix C - Cathodic Protection Design Checklist](#)

3.0 Target Audience

- Gas Engineering
- Distribution Design Center Supervisors
- Gas Tech Engineering
- Corrosion Control Supervisors
- Corrosion Control Specialists

4.0 Construction Order Review Processes

4.1 General

4.1.1 The purpose of Construction Order Review processes is to ensure that a person qualified in pipeline corrosion control methods reviews construction orders for changes made to the pipelines that affect the protection and monitoring systems for the new and existing piping.

4.1.2 A person qualified in pipeline corrosion methods shall review proposed gas designs in order to ensure that cathodic protection (CP) systems are optimized for the protection and monitoring of facilities and that CP records are kept up to date.

4.1.3 To achieve these goals, each qualified person should work with the following to ensure each understands their responsibility in maintaining cathodically protected gas facilities:

1. Gas Supervisors
2. Distribution Design Engineers
3. Field Engineering Representatives

UNCONTROLLED IF PRINTED

4. Region Engineering
5. Gas Tech Engineering.

4.1.4 The qualified person is designated by position within the processes below. The Supervisor - Corrosion Control or designee shall provide the review if the specified person is unable to do so.

4.2 Distribution Design Center (DDC)/Peoria Design Center (PDC)

4.2.1 Design Center Orders and Service Orders Impacting Steel Gas Facilities:

1. Preconstruction - Proposed Work

- 1 a. The person providing field notes to a Design Center shall provide a copy of the field notes to the Corrosion Technician or local engineer responsible for cathodic protection of the facilities whenever steel mains or services with steel components are impacted by the work, except when installing new farm tap services.

A design for modification of an existing farm tap does need to be sent for review.

- 1 b. When field notes are provided, the Corrosion Technician or the local engineer responsible for cathodic protection design in that area shall review the proposed work and provide direction related to cathodic protection requirements. See [Appendix A](#) Cathodic Protection Review Responsibility Table for person to contact.

2. Preconstruction - Final Design

The Design Center Supervisor is responsible to ensure that the Designer sends an email with a PDF file of the final construction print to the Corrosion Technician or local engineer responsible for cathodic protection of the facilities whenever steel mains or services with steel components are impacted by the work, except when installing new farm tap services.

A design for modification of an existing farm tap does need to be sent for review.

- 2 a. A hold will be placed on the DOJM by the Designer until the review is complete. See [Appendix A](#) Cathodic Protection Review Responsibility Table for person to contact.
- 2 b. The Corrosion Technician or engineer responsible for cathodic protection of the facilities shall review the proposed work and provide direction related to cathodic protection requirements and email the Designer with any changes needed in a timely manner.
- 2 c. The review will be documented when the hold on the DOJM has been cleared by the Corrosion Technician or the local engineer responsible for cathodic protection of the facilities.

3. Post Construction - As Built

- 3 a. As built work can be reviewed in Ameren Map Viewer (AMV) for changes from the final design.
- 3 b. The Corrosion Technician will add, delete, or change test points based on how the "as built" job may have changed a structure.
- 4. Gas Engineering Work (Work designed by Gas Tech Engineering or Consultant)
 - 4 a. Preconstruction - Proposed Work
 - (i) The Designer will send an email with a location map and a description of the proposed work.
 - (ii) The Corrosion Technician will review job for cathodic protection (CP) issues and communicate any necessary changes in a timely manner.
 - 4 b. Preconstruction - Final Design
 - (i) Corrosion Technicians need to review the final design prior to construction start.
 - (ii) The Designer will send a print of the final job to Corrosion Technician prior to issuing final packet.
 - (iii) The Corrosion Technician will review final design in a timely manner. Gas Engineering will include a bullet on their Design Checklist, see [Appendix C](#), for this step. The review will be documented on the Cathodic Protection Review stamp, shown in [Appendix B](#), included on the print.

When electronic copies of prints are reviewed, the title block can be filled out and attached to an email to document the review.

- (iv) The Corrosion Technician will e-mail Designer with any changes or approval of CP related design.
- 4 c. Post Construction - As BUILTS
 - (i) Corrosion Technicians need to review the "as built" print for field changes.
 - (ii) The DDC/PDC Poster will give a copy of the "as built" print to the Corrosion Technician if field changes were made.
 - a. If the facility is built as designed, the engineer will send an email stating no changes were made.

The Corrosion Technician will be contacted for input on any field changes that arise during construction.

- (iii) The Corrosion Technician will add, delete, or change test points based on how the "as built" job may have changed a structure.

- a. The Corrosion Technician will send mapping changes to the DDC/PDC for posting as needed.

Prints may be sent electronically or on paper.

4.3 Cathodic Protection Design Review Checklist

- 4.3.1 The checklist in [Appendix C](#) is intended to assist the Corrosion Technician in reviewing gas orders for cathodic protection related items.
- 4.3.2 This form is not required for each review but can be used and amended as necessary.

5.0 Additional Detail Information for Test Points

- 5.1 Some test point installations need additional information in order to locate the test point location or to place the half cell in the correct location. Examples of these test points are pipeline crossings and test points located in urban areas or in off the road locations.
- 5.2 Test Point Detail Sketch
 - 5.2.1 Each test point detail sketch may be attached to the asset within Maximo. See [Figure 1](#) & [2](#).

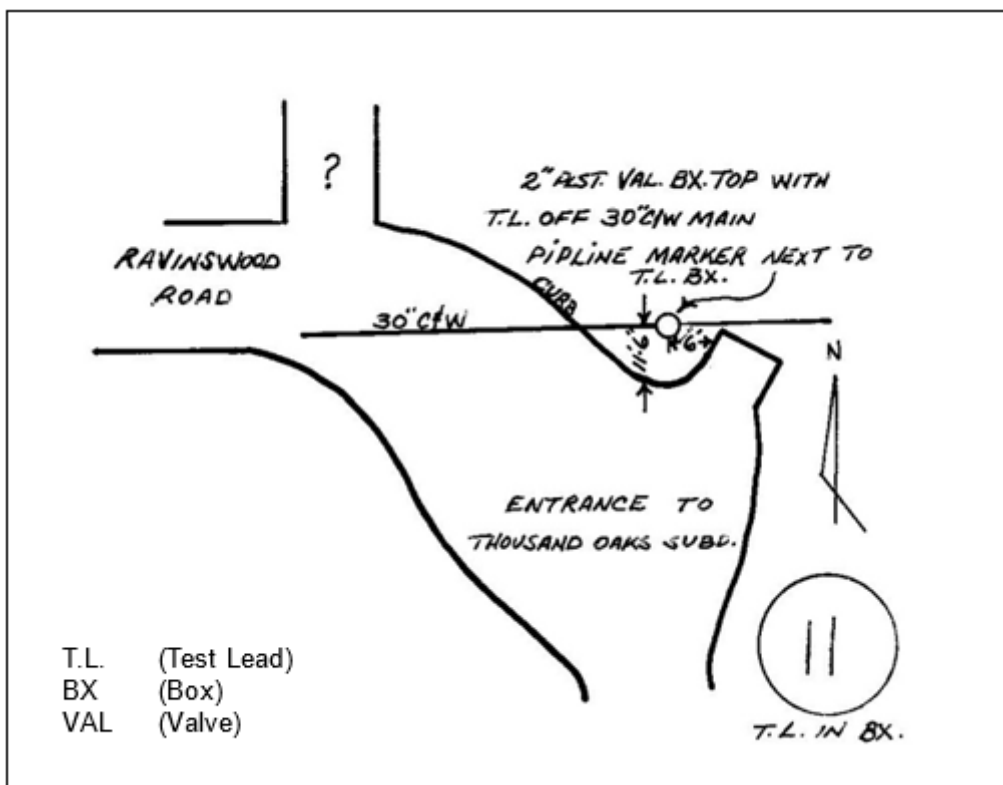

Figure 1 Test Point Detail Sketch

5.3 Pipeline Crossing Sketches

AmerenIP

Interference Bond/Pipeline Crossing Data

Area GALESBURG

STEVE REEDER 815-370-4723

Foreign Structure BP Amoco

Telephone 800-548-6482

Location BEHIND (SE) OF 1020 EIKER DR, KNOXVILLE

System No. 3066

Structure No. 001, 002

Bonded Yes No X

Chart of Locations of Pipe-to-Soil Readings. Readings recorded in GCS DEF RTE 43

TP ID Seg Fac ID	TP Description	Instrument @	Half-Cell @
18050C	AMEREN WHITE T/L OVER FOREIGN X-ING		I/C
5170294			
18050F	AMEREN YELLOW T/L OVER FOREIGN X-ING		I/F
5170200			

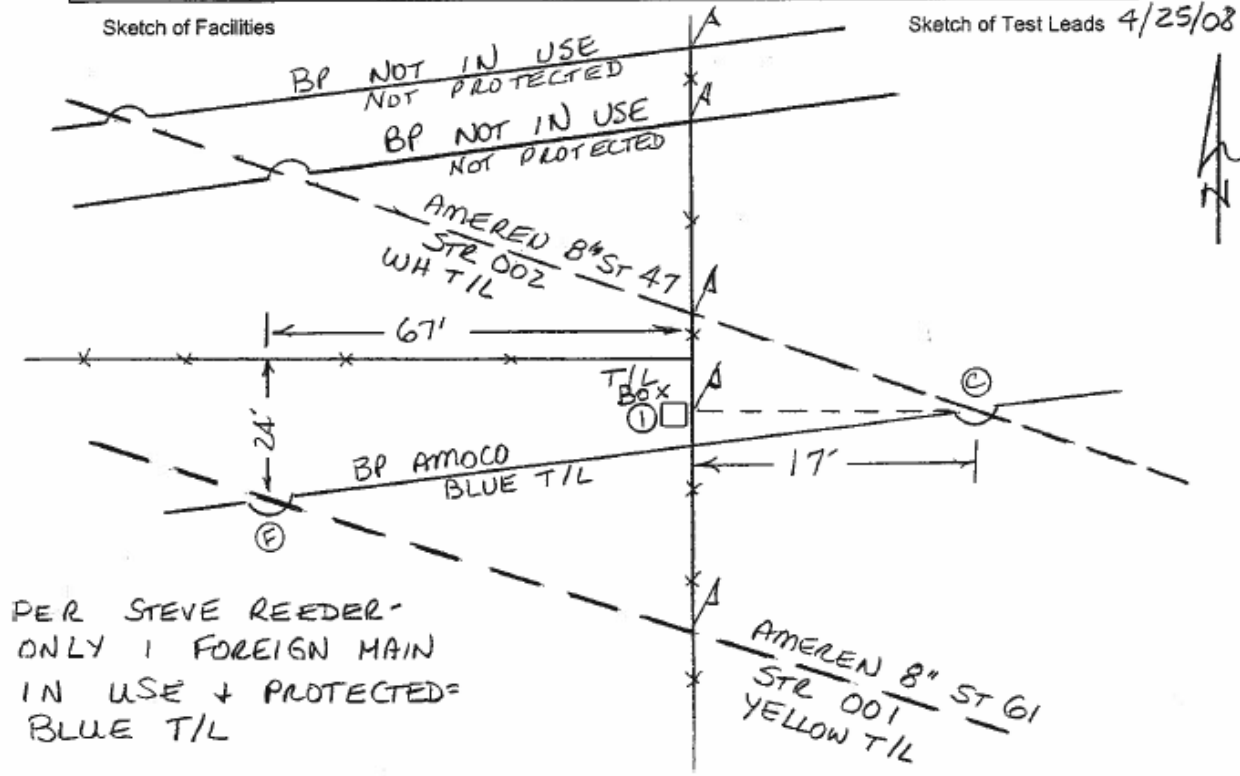

Figure 2 Pipeline Crossing

6.0 Other Cathodic Protection Record Activities

6.1 Pipe Exam Review Process

- 6.1.1 Transmission, high pressure distribution and distribution pipe Buried Pipe Examinations are completed within ClickMobile and stored in Maximo. See [CORR 1 Appendix A](#) Buried Pipe Examination Form.
- 6.1.2 For deficient pipe-to-soil potentials the review and investigation should consider:

UNCONTROLLED IF PRINTED

1. Are the annual test points for the structure also deficient?
2. If the deficient potential is at a service, is the service isolated?
3. If not, continuity must be verified for the pipe in question
4. If the pipe is continuous, test point locations must be reviewed to determine where additional test points need to be added to reflect the potential of the location of this deficiency.
5. The source of the deficiency must be determined and a corrective order prepared.

6.1.3 For corrosion found the review and investigation should consider:

1. The current cathodic protection potentials in the area.
2. The history of cathodic protection potentials in the area
3. The history of repaired leaks in the area and their cause.
4. Any deficient pipe-to soils need to be investigated as indicated above.

6.1.4 Corrective orders for deficient pipe-to-soil potentials not related to annual test points can be tracked in Maximo.

6.2 Annual Tasks

6.2.1 Each year the Corrosion Tech should review the testing and facility records for any updates or improvements that need to be made.

6.2.2 These are records related tasks that need to be performed on an annual basis:

1. Before December 31 check 10% of isolated read status. Refer to 49 CFR §192.465(a)
2. As needed, review routing for surveys
3. As needed, review structures and maps
4. As needed, perform T.P. Additions/Retirements/Changes
5. As needed, review electronics added to stations
6. As needed, review of voltage shifts at test points
7. Review rectified ground bed resistances
8. Review pipeline crossings as needed
9. As needed, review casing drawings or permits for casing details to be added as test point detail sketches in Maximo.

End of Instructions.

Operator Qualification (OQ) Required?

YES

0001: Measure Structure-to-Electrolyte Potential

0031: Inspect and monitor Galvanic Ground Beds/Anodes

Appendices

[Appendix A - Cathodic Protection Review Responsibility Table](#)

UNCONTROLLED IF PRINTED

[Appendix B - Cathodic Protection Review Stamp](#)

[Appendix C - Cathodic Protection Design Checklist](#)

Attachments

NONE.

Compliance Requirements

49 CFR §192.465 (a) External corrosion control: Monitoring.

Reference Documents

[CORR 1 Corrosion Control: Requirements](#)

Document Rescission

CORR 2.11 Corrosion Control: Records, April 1, 2021.

Revision Notes

Location of Changes	Summary of Changes
Appendix A - Cathodic Protection Review Responsibility Table	Updated the Technician/Specialist listing

Appendix A - Cathodic Protection Review Responsibility Table

Area(s)/Operating Centers	Technician/ Specialist
Peoria	Jeremy Sindle and Jason Bainter
LaSalle, Kewanee	Randy Biccochi
Galesburg	Michael Main
Canton, Macomb, Petersburg, Quincy	Jason Smith
Jacksonville, Jerseyville, Pittsfield, Beardstown	Sharon Ryman
Decatur	Chuck David
Springfield, Lincoln, and Tuscola (legacy CIL-CO Territory)	Mark Snow
Champaign, Danville, Hoopeston	Adam Hamilton
Mattoon, Paris, Robinson, North Pana, Effingham	Dave Wiegand
Maryville	Steve Frank
Hillsboro	Jeff Bergman
Mt Vernon, Sparta, Centralia, and eastern Belleville	Shara Sollers
Belleville and East St Louis	Tim Kern

Marion, Carbondale	Mike Gunter
--------------------	-------------

Appendix B - Cathodic Protection Review Stamp

Cathodic Protection Review
Order/Job Number: Click here to enter order/job number
System Protection: <input type="checkbox"/> Rectifier <input type="checkbox"/> Anode <input type="checkbox"/> Combination
Insulation: <input type="checkbox"/> Adequate <input type="checkbox"/> Update as Indicated
Test Leads: <input type="checkbox"/> Adequate <input type="checkbox"/> N/A <input type="checkbox"/> Update as Indicated
CP System Number: Click here to enter text. Notes: Click here to enter notes
Test Stations: <input type="checkbox"/> Adequate <input type="checkbox"/> N/A <input type="checkbox"/> Update as Indicated
Notes: Click here to enter notes
Reviewed by: Enter your name Date: Enter date reviewed

Appendix C - Cathodic Protection Design Checklist

Cathodic Protection Design Checklist		
DOJM #:	Date:	Reviewed by:
<input type="checkbox"/>	Regulator Stations and Insulators	
<input type="checkbox"/>	Test Stations (add, retire, change, flush or above ground)	
<input type="checkbox"/>	Tie-ins – review for loops (Steel or Plastic)	
<input type="checkbox"/>	System type (Galvanic or Rectifier)	
<input type="checkbox"/>	Bonds (Is one needed?)	
<input type="checkbox"/>	Anodes (How many? What size?)	
<input type="checkbox"/>	Transfer Rectifier Cables	
<input type="checkbox"/>	Structure Numbers/ K-pages (review and/or assign)	
<input type="checkbox"/>	Foreign crossing test facility	
<input type="checkbox"/>	AC Mitigation review	
<input type="checkbox"/>	Final Design Review (Optional)	

CORROSION CONTROL

April 1, 2023

CORR 3 Forms and Reference Materials

Click on the links below to open the documents.

Forms

1. Pipeline Crossing Sketch ([Word document](#)) ([PDF file](#))

References

1. [Fluke 77/75/73/70/23/21 Series II Multimeter Users Manual](#)
2. [Fluke 80 Series V Multimeters Users Manual](#)
3. [Fluke 114, 115, 117 True-rms Multimeters Users Manual](#)
4. [Fluke 175, 177 & 179 True RMS Multimeters Users Manual](#)
5. [Radiodetection Pipeline Current Mapper User Guide](#)
6. [M. C. Miller "CRONOS" Current Interrupter with Integral GPS Receiver for Accurate Clock Synchronization User's Manual](#)
7. [Tinker & Razor CS-10 Current Supply Instructions](#)
8. [Tinker & Razor PD Short Detector Instructions](#)
9. [Tinker & Razor RF-IT Insulator Tester Instructions](#)
10. [Tinker & Razor Product Instructions Model SR-2 Soil Resistivity Meter](#)
11. [Metrotech/Vivax vLocDM User Handbook](#)
12. [Vivax vLocPro User Handbook](#)
13. [Dryconn 50100-56-visiLock](#)
14. [Dairyland SSD Installation Instructions-3415](#)
15. [MTF Kit Installation with SSD](#)
16. [Denso Protal 7200 Repair Cartridge Data Sheet](#)
17. [Denso Protal 7125 Instructions Ver 1809.07](#)
18. [Denso Protal 7200 Instructions Ver 2006.04](#)
19. [Denso Protal 7300 Procedures Ver 1905.06](#)
20. [Denso Protal Air Cartridge Gun 1000 Setup Ver 1906.21](#)
21. [Denso-Glass-Outerwrap](#)
22. [Denso SeaShield 525 Epoxy](#)
23. [Denso SeaShield 526 Epoxy](#)
24. [Trenton MC110 Overwrap](#)
25. [Trenton EON 1000 GP Instructions](#)
26. [Trenton Fill-Pro PM-GP](#)
27. [Trenton Wax Tape Systems Brochure Rev10](#)

UNCONTROLLED IF PRINTED

28. [Syntho-Sleeve Installation Guide](#)
29. [Sherwin Williams Industrial Yellow Paint](#)
30. [Sherwin Williams Meter Set Grey Paint](#)
31. [Sherwin Williams Meter Hunter Green Paint](#)
32. [Sherwin Williams Ameren Medium Green Paint](#)
33. [Tnemec Endura-Shield Series 73 Paint](#)
34. [Tnemec Endura-Shield Series 1095](#)
35. [Tnemec Series 530 Omnithane Primere](#)
36. [Tnemec Omnithane Primer Series 1](#)
37. [Rustoleum Hunter Green Aerosol](#)
37. [CerAnode REF CELL - in Coupon Housing](#)
38. [Viscotag Pads](#)
39. [Elcometer 122 Testex Replica Tape](#)
40. [Elcometer 123 Surface Profile Gauge Operating Instructions](#)
41. [Elcometer 224 Digital Surface Profiling Gauge Operating instructions](#)
42. [Elcometer 224 Digital Surface Profiling Gauge User Guide](#)
43. [Denso's Letter Application Procedure Protal 7125, 7200, 7300, 2019_07_02](#)
44. [Borin Stelth 7 Reference Cell Instructions](#)
45. [Bullhorn – Triton AC Coupon Test Station](#)
46. [MATCOR Mitigator Splice Instructions](#)

Attachments

[ICC Final Order 05-0113](#)

End of Section.

Document Rescission

CORR 3 Corrosion Control: Forms and Reference Materials, October 1, 2022

Revision Notes

Location of Changes	Summary of Changes
Reference Materials	Added: Tnemec Endura-Shield Series 1095 Paint Tnemec Omnithane Series 1 Primer

CONS-Gas Construction Control

GAS CONSTRUCTION OVERSIGHT

October 1, 2020

CONS 0 Table of Contents

[CONS 1 Gas Construction Oversight: Requirements](#)

- Section 1.0 Purpose
- Section 2.0 Scope
- Section 3.0 Target Audience
- Section 4.0 Records, Maps, and Operating History
- Section 5.0 Coordinating Construction
- Section 6.0 Responsibilities
- Section 7.0 Construction Inspection
- Section 8.0 Major Focus Areas for Contractor Activities
- Operator Qualification (OQ)
- Compliance Requirements
- Reference Documents
- Document Rescission

[CONS 2 Gas Construction Oversight: Inspector Responsibilities](#)

- Section 1.0 Purpose
- Section 2.0 Scope
- Section 3.0 Target Audience
- Section 4.0 - Pre-job Considerations
- Section 5.0 Existing Facilities
- Section 6.0 Safety
- Section 7.0 Routine Activity
- Section 8.0 Record Requirements
- Section 9.0 Extras
- Operator Qualification (OQ)
- Compliance Requirements
- Reference Documents
- Document Rescission

End Table of Contents.

UNCONTROLLED IF PRINTED

Document Rescission

CONS 0 Gas Construction Oversight: Table of Contents, January 1, 2017.

Revision Notes

Location of Changes	Summary of Changes
Not applicable.	This is a new document.

GAS CONSTRUCTION OVERSIGHT

October 1, 2021

CONS 1 Requirements

1.0 Purpose

This document is to ensure that all gas construction, including that performed by outside contractors, meets the requirements of 49 CFR Part 192 and Title 83 of the ICC Code, plus the O&M Plan.

2.0 Scope

This document addresses the following:

[3.0 Target Audience](#)[4.0 Records, Maps, and Operating History](#)[5.0 Coordinating Construction](#)[6.0 Responsibilities](#)[7.0 Construction Inspection](#)[8.0 Major Focus Areas for Contractor Activities](#)**3.0 Target Audience**

- Gas Supervisor
- Construction Services Supervisor
- Construction Inspector
- Gas Control

4.0 Records, Maps, and Operating History

- 4.1 Construction records, maps, and operating history are available to field personnel, requesting such through the local Operating Center.
- 4.2 Gas system maps are accessed through the Ameren Illinois (AIC) map viewer.
- 4.3 Construction records and operating history are typically located based on the facility type and operating area. Portions of the operating history are typically maintained in Maximo.

5.0 Coordinating Construction

- 5.1 When construction (by AIC or contractor) might affect system operations or SCADA (or an ERX), the following shall communicate with Gas Control prior to beginning project and at completion:
 - 5.1.1 Gas Engineer,
 - 5.1.2 Gas Supervisor,
 - 5.1.3 Gas Tech Engineer,
 - 5.1.4 Construction Services Supervisor, or
 - 5.1.5 Construction Inspector.
- 5.2 Those construction activities might include

UNCONTROLLED IF PRINTED

- 5.2.1 Installing control fittings and shutting-off gas to a section of main.
- 5.2.2 Connecting two mains that could be at different pressures.
- 5.2.3 Isolating or temporarily by-passing a pressure control station/gas system.
- 5.2.4 Activating a new, rebuilt, or relocated pressure control station.
- 5.2.5 Upgrading a system or section.
- 5.2.6 Repairing a gas main that involves lowering the operating pressure.
- 5.2.7 Activating a significant extension.

Gas Engineer or Gas Tech Engineering to determine if extension is significant.

6.0 Responsibilities

- 6.1 The Gas Supervisor, Construction Services Supervisor, or the Construction Inspector is responsible (as applicable to respective projects) to ensure or verify the following:
 - 6.1.1 Personnel are qualified to perform construction activities in accordance with O&M Plan and current OQ requirements.
 - 6.1.2 Assigned personnel are aware of the associated gas system MAOP, method of cathodic protection, and whether remotely monitored facilities will be impacted.
 - 6.1.3 Work is performed in a manner that does not endanger the public or expose AIC to unnecessary risks.
 - 6.1.4 All activities meet the requirements of the O&M Plan through observation of gas construction.
 - 6.1.5 All "As-built" records and maps documenting the completed work are thoroughly and accurately established and submitted.
- 6.2 Other Duties
 - 6.2.1 Implement immediate corrective action if any gas construction activity is found to be out of compliance with the O&M Plan, federal / state regulations, or the approved construction plans.
 - 6.2.2 When applicable,
 - 1. Maintain coordination with public officials and owners of other affected facilities.
 - 2. Contact affected private property owners regarding timing and scope of the proposed work.

7.0 Construction Inspection

- 7.1 To ensure objectives are met, AIC will assign an inspector (either specific inspector, management employee, or field employee) to oversee contractor's work typically as follows:
 - 7.1.1 Major replacement projects (e.g., main replacements, relocations): full-time inspector for each project.

- 7.1.2 New business projects: inspector present during major focus areas (see [Sub-section 8.1](#) below for example list).

Generally, these projects require less oversight due to little interaction with existing customers, and construction is being done in predominantly undeveloped area. As such, it is expected that an inspector can oversee multiple projects within a given geographical area.

- 7.1.3 Transmission or high-pressure distribution projects: will require a full-time inspector due to the on-going welding of steel facilities. Inspector shall be present during major focus activities.

Off-site fabrication does not require a full time inspector but might warrant periodic inspection.

- 7.1.4 O&M projects: inspector present during major focus activities. These projects include:

1. Tapping/stopping.
2. Lowering of "main" into ditch.
3. Installing regulator or odorizer stations.
4. Leak repairs.
5. Service cut-offs.
6. Replacing service risers.

An inspector may be assigned to multiple crews working in various locations on small maintenance projects such as service cut-offs, replace/relocate existing service risers, and anode installation.

7. The Construction Inspector, Gas Supervisor, and Quality Assurance Consultants shall make periodic inspections of small, scattered work sites to ensure O&M procedures are followed.

- 7.2 The following shall attend Gas Construction Inspector Training prior to inspection duties:

- 7.2.1 Field employees.
- 7.2.2 Management personnel.
- 7.2.3 Hired contractors.

- 7.3 Construction Inspector Training shall include:

- 7.3.1 O&M Plan procedures for construction tasks.
- 7.3.2 Gas Construction Oversight procedures.

- 7.3.3 Related forms and documentation requirements.
- 7.3.4 Review of Quality Assurance Field Inspection forms.
- 7.3.5 An exam will follow.

8.0 Major Focus Areas for Contractor Activities

- 8.1 Major focus areas for added attention are:
 - 8.1.1 Large diameter tapping (4" and larger).
 - 8.1.2 Welding/plastic fusion (when project commences and periodically thereafter).
 - 8.1.3 Applying liquid epoxy coating.
 - 8.1.4 Inspecting steel coating (e.g., "jeeping").
 - 8.1.5 Ensuring proper backfill and depth of cover.
 - 8.1.6 Pressure testing of mains.
 - 8.1.7 Purging of main.
 - 8.1.8 Pigging of main.
- 8.2 Quality assurance (QA) inspections should be performed periodically while addressing major focus areas.
- 8.3 The inspector should document the QA inspections on the Quality Assurance Form. See [QUAL](#) section of the O&M Plan. Completed forms to be forwarded to Superintendent Quality Assurance.

End of Instructions.

Operator Qualification (OQ) Required?

YES

1371 Operate Gas Pipeline - System Control Center Operations

Appendices

NONE.

Attachments

NONE.

Compliance Requirements

- 49 CFR Part 192, Subpart E - Welding of Steel in Pipelines
- 49 CFR Part 192, Subpart F - Joining of Materials Other Than by Welding
- 49 CFR Part 192, Subpart G - General Construction Requirements for Transmission Lines and Mains
- 49 CFR Part 192, Subpart H - Customer Meters, Service Regulators, and Service Lines
- 49 CFR Part 192, Subpart J - Test Requirements

Reference Documents

[CONS 2 Gas Construction Oversight: Inspector Responsibilities](#)

UNCONTROLLED IF PRINTED

Document Rescission

CONS 1 Gas Construction Oversight: Requirements, April 1, 2021.

Revision Notes

Location of Changes	Summary of Changes
Target Audience	Added Gas Control
Operator Qualification	Added 1371 - System Control Center Operations

GAS CONSTRUCTION OVERSIGHT

October 1, 2021

CONS 2 Inspector Responsibilities

1.0 Purpose

This document outlines the responsibilities of the Construction Inspector who shall represent Ameren Illinois (AIC), ensure quality construction, and see that the work meets the requirements of 49 CFR Part 192 and Title 83 of Part 590 to ICC Code, plus the O&M Plan.

2.0 Scope

This document addresses the following:

[3.0 Target Audience](#)

[4.0 Pre-job Considerations](#)

[5.0 Existing Facilities](#)

[6.0 Safety](#)

[7.0 Routine Activity](#)

[8.0 Record Requirements](#)

[9.0 Extras](#)

3.0 Target Audience

- Construction Inspector
- Gas Supervisor
- Gas Tech Engineering
- Gas Control

4.0 Pre-job Considerations

- 4.1 Once a contractor has been selected, an inspector should be assigned to the specific job.
- 4.2 Upon receiving the work order packet, the inspector should:
- 4.2.1 Familiarize themselves with the work with packet and ensure it includes:
1. Latest project prints and bills-of-material.
 2. All permits.
 3. Necessary easements.
 4. Any special conditions or requirements.
 5. Applicable documentation forms.
- 4.2.2 Discuss with design personnel if there are any required communications with other groups such as:
1. Region Gas Operations,
 2. Gas Engineering,
 3. Gas Operations and Services - Technical Service Supervisor,

UNCONTROLLED IF PRINTED

4. Distribution Control (Dispatch), or

5. Gas Control.

4.2.3 Obtain necessary contact information and phone numbers.

4.2.4 Verify how the associated system is cathodically protected (either rectifier or sacrificial anodes) and if it contains equipment remotely monitored by Gas Control.

4.3 Inspector shall ensure all needed material is available: either on jobsite, in storeroom, or ordered and in transit.

4.4 Inspector should confirm that affected customers have been notified before beginning construction, informing them as to nature of the work.

4.5 Contractor should note condition of construction area to reduce false claims against both the contractor and AIC through such means as photographs and/or videos.

5.0 Existing Facilities

The inspector should ensure that:

5.1 Whenever necessary to interrupt customer service:

5.1.1 Be assured the customer is notified of the interruption, and

5.1.2 Arrange with appropriate operating center to restore service (if required).

5.2 Contractor is aware of all known underground facilities and has uncovered all of those which may conflict with Contractor's project.

5.3 Contractor shall notify JULIE, 811 -- the One-Call system -- and the owner of any damaged facility.

5.3.1 Replacements or repairs made by the contractor, or by anyone other than the owner of the damaged facility, are to be done to the satisfaction of that facility owner.

5.4 All damages are to be reported and properly recorded.

6.0 Safety

The Inspector shall ensure that:

6.1 All work is executed safely to prevent personal injury or property damage in accordance with the O&M Plan, local, state, and federal regulations.

6.2 Barricades, warning signals, and flagmen, when required, are provided by the contractor.

6.3 All excavations shall adhere to [EXCV](#) section of the O&M Plan.

6.4 General construction areas, material storage areas, and contractor's parking areas are kept clean, neat, orderly, and hazard-free at all times.

7.0 Routine Activity

The inspector shall:

7.1 Verify that all utility locates, permits, and easements are current.

7.2 Check status of material.

7.3 Verify that all parties are using latest drawings and specifications and are aware of the latest change orders.

- 7.4 Verify contractor employees are Operator Qualified (OQ) for work they are performing or otherwise working under direct supervision of an OQ individual. See [OQAL](#) section of the O&M Plan.
 - 7.4.1 Give specific attention to those functions involved in the respective construction scope, ensuring that all covered tasks outlined in [OQAL 2.01](#) are fully addressed and documented.
 - 7.4.2 Contractor is responsible to have a copy of individual qualifications on site.
- 7.5 Determine that all work (to include drawing details and design specifications) is done in strict accordance with O&M procedures plus all local, state, and federal regulations.
- 7.6 Coordinate contractor's construction activities (to include tapping, tie-ins, purging) with the appropriate AIC operating centers.
- 7.7 Resolve questions and conflicts with the appropriate personnel.

8.0 Record Requirements

The inspector shall ensure:

- 8.1 See [Subsection 7.4](#) for OQ records requirement.
- 8.2 Contractor submits completed daily progress reports for AIC approval.
- 8.3 As-built drawings showing accurate details and measurements are kept up to date as the job progresses to include:
 - 8.3.1 Any variations of main and service locations from those shown on the original drawings.
 - 8.3.2 Actual footage of mains and services installed are verified with the contractor.
 - 8.3.3 Complete for the following items:
 - 1. Anodes.
 - 2. Test-lead wire boxes.
 - 3. Insulators.
 - 4. Valves.
 - 5. Other fittings.

Complete details and measurements are required for recording in the electronic map

- 8.4 Documenting circumstances causing a slow-down or work-stoppage to include:
 - 8.4.1 Permit delays or violations.
 - 8.4.2 Material problems.
 - 8.4.3 Incident or accidents.
 - 8.4.4 Any other delays.
- 8.5 Paving repair orders are completed per local, state, and federal requirements.
- 8.6 When the job is completed, following records are submitted to the appropriate Gas Supervisor and/or Gas Tech Engineering for review (accuracy and completeness):

UNCONTROLLED IF PRINTED

- 8.6.1 "As-built" drawings and related tie-in sketches.
- 8.6.2 Material detail.
- 8.6.3 Field notes.
- 8.6.4 Pressure test records.
- 8.6.5 If applicable, radiographic or other non-destructive inspection records.
- 8.6.6 Any other construction details.

9.0 Extras

Extras are defined as any significant change or deviation from the original work scope.

- 9.1 The inspector should avoid extras whenever possible but resolving such promptly and not allowed to accumulate until the end of the job.
- 9.2 If a major scope change is encountered, the inspector and related supervisor should meet with the contractor before making the change to discuss potential impact, cost factor, and resolve agreement.
- 9.3 The inspector should note on the appropriate drawing and progress report the authorizing person's name and date.

End of Instructions.

Operator Qualification (OQ) Required?

YES

1371 Operate Gas Pipeline - System Control Center Operations.

Appendices

NONE.

Attachments

NONE.

Compliance Requirements

49 CFR Part 192, Subpart E - Welding of Steel in Pipelines

49 CFR Part 192, Subpart F - Joining of Materials Other Than by Welding

49 CFR Part 192, Subpart G - General Construction Requirements for Transmission Lines and Mains

49 CFR Part 192, Subpart H - Customer Meters, Service Regulators, and Service Lines

49 CFR Part 192, Subpart J - Test Requirements

Reference Documents

[CONS 1 Gas Construction Oversight: Requirements](#)

[EXCV Excavation Safety](#)

[OQAL Operator Qualification](#)

Document Rescission

UNCONTROLLED IF PRINTED

CONS 2 Inspector Responsibilities, April 1, 2021.

Revision Notes

Location of Changes	Summary of Changes
Target Audience	Added Gas Control
Operator Qualifications	Added 1371 – System Control Center Operations

DAMG-Damage Prevention

DAMAGE PREVENTION

April 1, 2023

DAMG 0 Table of Contents

[DAMG 1 Damage Prevention: Requirements](#)

Section 1.0 Purpose

Section 2.0 Scope

Section 3.0 Target Audience

Section 4.0 Types of Locate Requests

Section 5.0 Illinois One-Call System - JULIE

Section 6.0 Damage Prevention Notification to Excavators and Public

Section 7.0 Inspection of Excavation or Construction Activities

Section 8.0 Excavating Near a Transmission Pipeline, High-Pressure Distribution, or Steel Main 8" and larger

Section 9.0 Emergency Locate Requests

Section 10.0 Facility Location Information

Section 11.0 Back-Flagging

Section 12.0 QA Process

Section 13.0 Records and Reports

Operator Qualification (OQ)

Compliance Requirements

Reference Documents

Document Rescission

[DAMG 2 Damage Prevention: Reporting JULIE Violators](#)

Section 1.0 Purpose

Section 2.0 Scope

Section 3.0 Target Audience

Section 4.0 Procedures

Section 5.0 Investigation of Reportable Violation

Section 6.0 Reporting a Suspected Violation

Section 7.0 Commission Review of Reported Violation

Section 8.0 Notification of Damaged Underground Facilities

Operator Qualification (OQ)

UNCONTROLLED IF PRINTED

Compliance Requirements

Reference Documents

Document Rescission

End Table of Contents.

Document Rescission

DAMG 0 Damage Prevention: Table of Contents, October 1, 2020.

Revision Notes

Location of Changes	Summary of Changes
DAMG 1	Inserted new section 11.0 Back-Flagging

1.0 Purpose

This document is to ensure that a Damage Prevention Program is established by Ameren Illinois (AIC) to prevent damage to underground pipelines during excavation activities and to fully meet the requirements of 49 CFR Part 192, specifically §192.614, and Title 83 of the ICC Code. Program includes participation in the Illinois One-Call program (JULIE).

2.0 Scope

This document addresses the following:

[3.0 Target Audience](#)

[4.0 Types of Locate Requests](#)

[5.0 Illinois One-Call System - JULIE](#)

[6.0 Damage Prevention Notification to Excavators and Public](#)

[7.0 Inspection of Excavation or Construction Activities](#)

[8.0 Excavating Near a Transmission Pipeline, High-Pressure Distribution, or Steel Main 8" and Larger](#)

[9.0 Emergency Locate Requests](#)

[10.0 Facility Location Information](#)

[11.0 Back-Flagging](#)

[12.0 QA Process](#)

[13.0 Records and Reports](#)

3.0 Target Audience

- Gas Engineering
- Gas Distribution Design
- Gas Supervisors
- Gas Field Personnel
- Gas Construction Personnel
- Gas Construction Services Personnel

4.0 Types of Locate Requests

4.1 General

4.1.1 Locating (and identifying) underground gas facilities is required for all excavation activities including:

1. General excavating,
2. Blasting,
3. Boring,
4. Tunneling,

5. Backfilling.
 6. Removing aboveground structures (by either explosive or mechanical means), or
 7. Other earthmoving operations.
- 4.1.2 Illinois state law requires all excavators, whether contractors, businesses, landowners or homeowners, to contact JULIE a minimum of 48 hours or 2-business days (exclusive of Saturdays, Sundays, and holidays) before any excavation.
- 4.1.3 A locate request is submitted to JULIE through one of the following means:
1. Remote Ticket Entry (RTE) - For professional excavators. AIC utilizes RTE.
 2. On-line with E-Request for non-emergency locate requests- For homeowners and excavators. (www.illinois1call.com)
 3. One-Call number 811
- 4.1.4 The types of "Locate Requests" that excavators may make to report pending excavation and request marking of underground facilities are outlined in sections below.

4.2 Normal Locate

- 4.2.1 A typical locate request provides *advance notice* of excavation to JULIE *48 hours prior to start*. Business day begins at 8 AM and ends at 4 PM. Requests for locates received after hours will be processed the next business day.
- 4.2.2 Excavation *must start within 14 calendar days* from date of locate request (includes day of call); otherwise, ticket becomes invalid.
- 4.2.3 When excavation extends past 28 days from original notice, an extension **MUST** be requested between 20th and 28th calendar day; otherwise, ticket becomes invalid and excavation work must cease after ticket's expiration date.

4.3 Emergency Locate

- 4.3.1 An emergency locate request necessitates immediate repair or action such as the following:
1. Any condition constituting an imminent danger to life, health, or property,
 2. Repair for utility service outage.
 3. Attention to some environmental danger.
 4. Unstable condition that might result in any of the above conditions (e.g., a *hazardous* leak in any service or main).
 5. An open-cut utility locate.
- 4.3.2 All emergency locate requests must be processed immediately.
- 4.3.3 Facility owners are required to respond within 2 hours.
- 4.3.4 Excavators are required to wait the 2 hours, or the date / time requested on notice, whichever is longer. If site conditions at the site dictate an earlier start than the required wait time, it is responsibility of the excavator to demonstrate that the site warranted the early start time. Otherwise, they may be responsible for damage to unmarked facilities if starting prematurely.

4.4 Joint Meet

- 4.4.1 The Joint Meet Request is to openly discuss a large / complicated project. It is not a valid locate request, but for planning coordination only and exchange information to include:
 - 1. Maps.
 - 2. Plans.
 - 3. Schedules.
- 4.4.2 Joint meet should be held at the dig site or location in proximity.
- 4.4.3 Excavator is required to obtain respective locate request separately following the joint meeting.
- 4.4.4 A joint meet is a minimum 48-hour process.

5.0 Illinois One-Call System -- JULIE

5.1 General Notes

- 5.1.1 The following are not business days: Saturday, Sunday, and the observed day for the following holidays: New Year's Day, Memorial Day, Independence Day, Labor Day, Thanksgiving Day, Day after Thanksgiving and Christmas Day.
- 5.1.2 *Normal business hours for JULIE: 8 AM to 4 PM Central Time.* For Non-Emergency JULIE calls received after 4PM, request will be processed as if received at 8 AM on the next business day. Hence, the locator has 2 full business days to mark facilities.
- 5.1.3 AIC prohibits the use of "waive call-back" option for all generated locate requests.

5.2 Ticket Transmittal

5.2.1. Locate Tickets

- 1. When JULIE receives a locate request, the proposed dig site is located on their electronic map, which also contains approximate location of some buried facilities by the owning utility.
- 2. AIC provides JULIE monthly reports with electronic mapping of (electric and) gas buried facilities.
- 3. A polygon that surrounds AIC facilities is reflected on JULIE's mapping system. If the proposed dig site is within the polygon, a JULIE Dig Request Notice is sent to AIC and/or its representative.

5.2.2 Emergency Locate Tickets

- 1. Each Emergency Ticket is transmitted to AIC and/or its representative.
- 2. AIC to make a quick review to determine if any AIC facility is in dig site area and acts as follows.
 - 2 a. If AIC facility could be affected, ticket is forwarded to the appropriate locating contractor.
 - 2 b. If no AIC facilities involved, clear ticket and initiate notification to excavator.

5.2.3 No- Response Tickets

1. If a Locate Request is received, but no underground facilities are operated within the area, the person who initiated the Ticket must be notified unless "waived call back" (emergency requests cannot be waived).
2. AIC will provide positive response of no underground facilities by one of the following.
 - 2 a. Face-to-face communication.
 - 2 b. Phone or phone voice mail.
 - 2 c. Electronic mail (E-Mail).
 - 2 d. Facsimile (FAX).
 - 2 e. Mark the area with paint or place flags that indicate no AIC facility is present.
3. All Excavators requesting facilities to be located are required to provide phone number to JULIE where they can be reached for added communication.

5.2.4 Difficult to Locate Facilities

1. Facilities that are difficult to locate should be reported to the appropriate Gas Supervisor to ensure additional actions are taken to identify the location of the facilities.
2. Additional actions may include:
 - 2 a. Review of system maps.
 - 2 b. Review of main or service line construction records.
 - 2 c. Probe the facilities.
 - 2 d. Use of other approved locating methods such as:
 - Locatable pipe rodder, or
 - Acoustic line locator
 - 2 e. Coordinate with the excavator for such actions as:
 - AIC excavating to expose the facility. (Requires an Emergency Locate request by AIC)
 - Isolate the facility from the gas system.
 - Isolate the facility from the gas system.
 - As a last resort, gas field personnel stand-by while excavation crosses the facility
3. Gas field personnel who are standing by to observe the excavation should take the following actions once the gas facility is exposed:
 - 3 a. Take measurements that can be recorded for future locates.
 - 3 b. Record measurements on their ClickMobile maps, take a screen shot, attach to a GIS discrepancy and incomplete it within ClickMobile.

- Measurements on exposed mains should be submitted to the appropriate group for recording on the electronic gas mapping system for future reference.
- 3 c. Check for the presence and condition of trace wire when PE pipe is exposed.
- If the tracer wire is in good condition, report this to the Gas Supervisor for follow-up investigation to determine if the tracer wire has been cut and could be repaired.

6.0 Damage Prevention Notification to Excavators and Public

- 6.1 Annual notification to be sent to known excavators in AIC service area advising of Damage Prevention Program and informing how to contact JULIE for assistance in locating pipeline facilities. Maintenance and coordinating of the notification list are handled jointly by Damage Prevention and Public Awareness groups.
- 6.2 The list of excavators should include:
- Excavators, agricultural field tiling contractors.
 - Contractors, construction companies.
 - Engineering firms.
 - Telephone and cable companies.
 - Electric utilities and electric co-operatives.
 - Pipeline and natural gas companies.
 - Water and sewer utilities.
 - City governments.
 - County governments.
 - Special road districts.
 - Special water and sewer districts.
 - Highway department districts.
- 6.3 AIC will maintain a list of known excavators and field tiling contractors that could operate within AIC territory. The list will be developed from various sources including state contractor licensing boards, local associations, JULIE, and AIC operating areas. Further actions are as follows.
- 6.3.1 Update list annually.
- 6.3.2 Distribute notification annually to known excavators and field tiling contractors.
- 6.3.3 Distributes letter with copy of JULIE Farming Brochure to known field tiling contractors.
- 6.4 Semi-annual notifications will be sent to general public in AIC gas service area advising of damage prevention program and to inform how to contact JULIE for assistance in locating natural gas facilities. The notifications are scheduled / initiated by the AIC Communications / Public Relations Department. Notices will be given through:
- 6.4.1 Newspaper advertisements, and
- 6.4.2 Billing messages (customer's monthly bill).
- 6.5 When AIC becomes aware of excavators who are not utilizing the One Call system, the excavator is contacted and provided information on JULIE regulations and hazards of excavating without first locating buried utilities.

UNCONTROLLED IF PRINTED

7.0 Inspection of Excavation or Construction Activities

- 7.1 Inspection of any excavation near pipeline facilities may be necessary during excavation or construction activities where AIC has reason to believe the activity could damage pipeline facilities. For operator qualifications (OQ) applicable to inspection activity, see [OQAL 1](#), Requirements, and [OQAL 2.1](#), Covered Task List for Numbers 1321 and 1331.
- 7.2 The inspection must be done as frequently as necessary, during and after the excavation or construction, to ensure the facilities are protected and to detect and repair any damage.
- 7.3 In the case of blasting activity within 100 feet of a gas facility, the inspection must include leak survey.

8.0 Excavating Near a Transmission Pipeline, High-Pressure Distribution, or Steel Main 8" and Larger

- 8.1 AIC must take special precautions for Locate Requests in vicinity of all transmission pipelines, steel distribution mains 8-inch and larger, and other distribution facilities with 100 psig MAOP or greater.
 - 8.1.1 Locator will use flags and marking paint.
 - 8.1.2 When locator determines excavation might be within 15 feet, the locator will forward Locate Request to AIC Damage Prevention group.
- 8.2 Particular care should be taken to ensure that excavating, boring, or other trenchless technology do not accidentally contact or damage existing underground facilities.
 - 8.2.1 When excavator plans to use trenchless technology near existing gas facilities, a site survey should be conducted by the excavator to identify any potential conflicts.
 - 8.2.2 As stated in Illinois Underground Utility Facilities Damage Prevention Act (Section 4(b)), the excavator is required to plan excavation or demolition to avoid / minimize interference with underground utility facilities within the tolerance zone. They shall use precautions such as the following while excavation is in progress and until clear of the existing marked facility:
 1. Hand excavation.
 2. Vacuum excavation methods.
 3. Visually inspecting.
- 8.3 AIC personnel or qualified contractor must verify location of excavating activities, contact the excavator, and monitor the excavation by taking the following actions as appropriate.
 - 8.3.1 Where activity is *within 15 feet*, AIC Damage Prevention personnel (or qualified contractor) will contact the excavator to inform them that an additional evaluation may be required.
 - 8.3.2 Where activity is *within 15 feet*, AIC Damage Prevention personnel (or qualified contractor) shall monitor the excavation site and document activities. All documentation shall be maintained on the Damage Prevention and Monitoring SharePoint site or by local area. The location of the excavation and the condition of facility, if exposed, shall be documented on the Buried Pipe Examination form within ClickMobile (or electronic equivalent). See [CORR 1 Appendix A](#).

8.3.3 Where excavation activity is *not within 15 feet*, AIC Damage Prevention personnel (or qualified contractor) shall document findings and maintain such on the Damage Prevention and Monitoring SharePoint site or by the local area. No further action is required.

8.4 AIC personnel (or qualified contractor) must visually inspect site while excavating or boring and back reaming operations are in progress and until those operations clear the existing marked facility and facility verified not damaged. A Buried Pipe Examination form shall be completed within ClickMobile (or electronic equivalent) if the facility is exposed. See [CORR 1 Appendix A](#).

9.0 Emergency Locate Requests

9.1 Near Transmission, High Pressure Distribution, or 8" and Larger Steel Main

9.1.1 In addition to responding to the locate request, AIC must take special precautions for emergency excavation notices in the vicinity of:

1. Transmission main,
2. High pressure distribution facility with MAOP of 100 psig or greater,
or
3. Steel distribution main 8 inches and larger.

9.1.2 When excavation on an Emergency Locate Request may be *within 15 feet* of a facility listed below, Locator will notify Damage Prevention personnel of the excavation and remain at the site until relieved by a qualified AIC personnel or qualified contractor.

1. Transmission main,
2. High pressure distribution facility with MAOP of 100 psig or greater,
or
3. Steel distribution main 8 inches and larger.

9.2 Train Derailment Site

9.2.1 When there is locate request at the site of a railroad train derailment, the locator shall notify AIC Damage Prevention personnel once it is determined there is a gas line in vicinity of the derailment. If there is a gas line in the vicinity, Damage Prevention personnel or the locator will notify local Gas Supervision.

9.2.2 If there is a gas odor in the area, locator shall call the AIC Emergency number 1.800. 755.5000 to report a leak.

9.2.3 Damage Prevention personnel and/or local qualified gas personnel should meet with the railroad representative and emergency response personnel. See [EMER 2.4.8](#), Gas Field Personnel, Train Derailment near Pipeline Facilities.

10.0 Facility Location Information

10.1 Each Operating Region / Business Unit is responsible to ensure "as-built" information is submitted timely to those individuals or groups responsible for maintaining the electronic gas system maps.

10.2 Update electronic mapping system (in G/Tech) within 90 days following approval of completed job packet. See [MAIN 1](#).

- 10.3 AIC to provide updated map information monthly from the electronic mapping system to the JULIE One-Call Program.

11.0 Back-Flagging

- 11.1 Excavation damage prevention best practices have shown "back-flagging" is effective to prevent 3rd party damage to newly installed facilities. AIC and contractor crews are required to back flag all newly installed facilities.
- 11.2 Place "Yellow" locating flags or yellow headed stakes and/or yellow marking paint over the new facilities.
- 11.3 Place enough flags/stakes to ensure the facilities are clearly identified as to route and location.

12.0 QA Process

- 12.1 The Damage Prevention Group will evaluate performance of locating contractors to ensure locates are:
 - 12.1.1 Performed accurately and in a timely manner, and
 - 12.1.2 Personnel are qualified per [OQAL 1](#), specifically Covered Task Number 1291 to "Locate Underground Pipelines."
- 12.2 AIC personnel and locating contractor supervision to investigate known inaccurate locates or missed locates to determine why situation occurred.
- 12.3 The Damage Prevention Group has electronic access to locating contractor's ticket system so real-time monitoring should be performed on as-needed basis.
- 12.4 Hold periodic meetings between AIC Damage Prevention Group and locating contractor management to review performance matrix.

13.0 Records and Reports

- 13.1 Retain copies of completed excavation notices for 2 years, either by:
 - 13.1.1 AIC, or
 - 13.1.2 Locating contractors who marked facilities.
- 13.2 Retain documentation on monitoring excavation for life of facility.
- 13.3 Retain buried Pipe Examination forms as follows:
 - 13.3.1 Completed prior to November 1, 2014 -- life of facility.
 - 13.3.2 Beginning November 1, 2014, completed within ClickMobile -- maintain in Maximo for life of facility.

Otherwise, information from electronic equivalent to be maintained until procedures are available for entering Maximo.

End of Instructions.

Operator Qualification (OQ) Required?

YES

1291: Locate Underground Pipelines

UNCONTROLLED IF PRINTED

1321: Damage Prevention During Excavation Activities by or on Behalf of The Operator

1331: Damage Prevention During Third Party Excavation or Encroachment Activities as Determined Necessary by Operator

Appendices

NONE.

Attachments

NONE.

Compliance Requirements

49 CFR §192.614 Damage prevention program.

49 CFR §192.805 Qualification program.

Reference Documents

[CORR 1 Corrosion Control: Requirements, Appendix A - Buried Pipe Examination Form](#)

[DAMG 2 Damage Prevention: Reporting JULIE Violators](#)

[EMER 2.4 Emergency Plan: Gas Field Personnel - General](#)

[MAIN 1 Main Installation: Requirements](#)

[OQAL 1 Operator Qualification: Requirements](#)

[OQAL 2.1 Operator Qualification: Covered Task List](#)

[OQAL 4 Operator Qualification: Forms and Reference Materials](#)

[SERV 1 Service Line Installation: Requirements](#)

JULIE Excavator Handbook - available online [here](#).

Document Rescission

DAMG 1 Damage Prevention: Requirements, October 1, 2022

Revision Notes

Location of Changes	Summary of Changes
2.0 Scope	Inserted new Section 11.0 Back-Flagging
Subsection 5.1	Moved Paragraph 5.1.4 language to new Section 11.0
Section 11.0 – Back-Flagging	New Section contains language previously in Paragraph 5.1.4
Subsection 13.4	Removed – The Illinois Damage Prevention Act Incident Report is completed by AIC Damage Prevention personnel and is covered in DAMG 2 – Reporting JULIE Violations

DAMAGE PREVENTION

October 1, 2022

DAMG 2 Reporting JULIE Violators**1.0 Purpose**

This document outlines the procedures for reporting excavators that violate the Illinois Underground Utility Facilities Damage Prevention Act (JULIE law). Any person can report a violation to Illinois Commerce Commission (Commission) per 83 Illinois Administrative Code, Section 265.100 Reportable Violations.

2.0 Scope

This document addresses the following:

[3.0 Target Audience](#)**[4.0 Reportable Violations](#)****[5.0 Investigation of Reportable Violation](#)****[6.0 Reporting a Suspected Violation](#)****[7.0 Commission Review of Reported Violation](#)****[8.0 Notification of Damaged Underground Facilities](#)****3.0 Target Audience**

- Gas Engineering
- Gas Distribution Design
- Gas Supervisors
- Gas Field Personnel
- Gas Construction Personnel
- Gas Construction Services Personnel

4.0 Reportable Violations

4.1 The following types of digging incidents that result in a gas leak on a main shall be reported:

Reference to "digging incident" is not to be confused with "Incident" as defined in 49 CFR §192.3, resulting in more serious consequences and requiring additional reporting. However, a digging incident could result in being a specific and reportable pipeline incident. See [INCD](#).

4.1.1 No JULIE dig number.

4.1.2 Expired JULIE ticket.

4.1.3 Prior to start date / time on JULIE ticket.

4.1.4 Outside the boundaries of JULIE ticket

4.1.5 Other:

1. Using power machinery without first potholing to locate the facilities.

UNCONTROLLED IF PRINTED

2. Failing to take precautions, such as hand excavation, within a tolerance zone of 18 inches on either side of the facility as defined by the markings.
3. Failing to immediately notify the utility of facility damage.

4.2 Additional types of incidents that should be reported:

- 4.2.1 Excavator that repeatedly disregards the requirement to hand excavate service lines.
- 4.2.2 Requesting emergency locate when no emergency exists.
- 4.2.3 Failure to mark underground facilities or improperly mark.
- 4.2.4 Destruction of underground facility marks by someone not involved in the excavation.
- 4.2.5 An outage to the provider of a 911 system.
- 4.2.6 A suspected violation that results in a fatality or personal injuries requiring hospitalization.

- 4.3 A contractor or utility excavator, including Ameren Illinois (AIC), that is suspected to have violated the JULIE law and damages AIC facilities that results in a gas leak on a main shall be reported to the Gas Supervisor and/or Damage Prevention personnel at the earliest practical moment.

5.0 Investigation of Reportable Violation

- 5.1 Once a violation is reported, Damage Prevention personnel shall investigate and document such on the Illinois Underground Utility Facilities Damage Prevention Act Incident Report. The investigation should be thorough and include:
 - 5.1.1 Completed report.
 - 5.1.2 Photos.
 - 5.1.3 Sketches.
 - 5.1.4 Any other supporting information.

6.0 Reporting a Suspected Violation

- 6.1 For a suspected violation, Damage Prevention personnel will prepare an Incident Report for review by Regulatory personnel. Incidents identified as suspected to have violated the JULIE law that require reporting will be sent to the Commission *within 45 days* of the suspected violation.

7.0 Commission Review of Reported Violation

- 7.1 Upon receipt of Incident Report for violation, Commission Staff will assign a JULIE Enforcement Case Number and notify all parties in writing. The review will follow the process outlined in Illinois Administrative Code, Title 83, Section 265.200.
- 7.2 If the Staff determines there is no violation, all parties will be notified in writing and the matter closed.
- 7.3 Administrative penalty may be assessed under the jurisdiction of the Commission for violation of the JULIE law.

8.0 Notification of Damaged Underground Facilities

- 8.1 When damage occurs to any underground facility, the excavator that inflicted damage is required to notify JULIE and the facility owner.

- 8.2 When JULIE receives notification that an underground facility has been damaged, they issue a "Damage" notice to all utilities that have facilities in the area. The "Damage" notice by JULIE is for information only; no action is required.
- 8.3 In event of damage to any underground utility facility (including AIC facilities damaged by AIC crews or their contract crews) that results in escape of any flammable, toxic, or corrosive gas or liquid, the person responsible for the excavation or demolition shall call 911 to notify authorities.

If AIC crew hits an AIC gas line that results in escaping gas, a 911 call is required. However, if fire or police personnel are not needed, AIC representative making the call can inform 911 operator that AIC crew is on site and has situation under control.

End of Instructions.

Operator Qualification (OQ) Required?

NO.

Appendices

NONE.

Attachments

NONE.

Compliance Requirements

49 CFR §192.614

(See reference documents)

Reference Documents

[DAMG 1 Damage Prevention: Requirements](#)

[INCD Incident Reporting](#)

49 CFR §192.3 Definitions.

49 CFR §192.614 Damage prevention program.

JULIE Excavator Handbook - available online [here](#).

Illinois Administrative Code, Title 83 - Part 265 Protection of Underground Utility Facilities, to include Section 265.200 - available online [here](#).

Document Rescission

DAMG 2.01 Damage Prevention: Reporting JULIE Violators, October 1, 2020

Revision Notes

Location of Changes	Summary of Changes
----------------------------	---------------------------

UNCONTROLLED IF PRINTED

Paragraph 4.1.5 – Item 2	18 inches replaced 1-1/2 feet on either side of marked facilities. Tolerance Zone.
Reference Docu- ments	Removed - The Illinois Underground Utility Facilities Damage Prevention Act. This Act is included in the JULIE Excavator Handbook which is also a Reference Document.

EMER-Emergency Plan

EMERGENCY PLAN

October 1, 2022

EMER 0 Table of Contents

[EMER 1 Emergency Plan: Requirements](#)

- Section 1.0 Purpose
- Section 2.0 Scope
- Section 3.0 Target Audience
- Section 4.0 General
- Section 5.0 Procedures
- Operator Qualification (OQ)
- Compliance Requirements
- Reference Documents
- Document Rescission

[EMER 2.1 Emergency Plan: Customer Care Center](#)

- Section 1.0 Purpose
- Section 2.0 Scope
- Section 3.0 Target Audience
- Section 4.0 General
- Section 5.0 Receiving Natural Gas Odor or Leak Call
- Section 6.0 Receiving Request to Cancel Natural Gas Odor or Leak Call
- Section 7.0 Receiving Fire or Explosion Call from Emergency Agencies
- Section 8.0 Receiving Carbon Monoxide Call from Emergency Agencies
- Section 9.0 Receiving Carbon Monoxide Call from General Public or AIC Customer
- Operator Qualification (OQ)
- Compliance Requirements
- Reference Documents
- Document Rescission

[EMER 2.2 Emergency Plan: Dispatch Center](#)

- Section 1.0 Purpose
- Section 2.0 Scope
- Section 3.0 Target Audience

UNCONTROLLED IF PRINTED

Section 4.0 General

Section 5.0 Dispatching Gas Field Personnel to Emergency Call

Section 6.0 Actions Required of Supervisory Personnel

Section 7.0 Cold Weather Electrical Outages and Restoring Service

Operator Qualification (OQ)

Compliance Requirements

Reference Documents

Document Rescission

EMER 2.3 Emergency Plan: Emergency Responder

Section 1.0 Purpose

Section 2.0 Scope

Section 3.0 Target Audience

Section 4.0 General

Section 5.0 Dispatched to Indoor Odor or Leak

Section 6.0 Dispatched to Outdoor Odor or Leak

Section 7.0 Dispatched to Cut Main or Service

Operator Qualification (OQ)

Compliance Requirements

Reference Documents

Document Rescission

EMER 2.4 Emergency Plan: Gas Field Personnel General

Section 1.0 Purpose

Section 2.0 Scope

Section 3.0 Target Audience

Section 4.0 General

Operator Qualification (OQ)

Appendices

Appendix A - OAS 6H Screen Shot: Meter Valve Shut Off and Red Pin

Compliance Requirements

Reference Documents

Document Rescission

EMER 2.4.1 Emergency Plan: Gas Field Personnel Dispatched to Indoor Odor or Leak

Section 1.0 Dispatched to Indoor Odor or Leak

Document Rescission

EMER 2.4.2 Emergency Plan: Gas Field Personnel Dispatched to Outdoor Odor or Leak

Section 1.0 Dispatched to Outdoor Odor or Leak

Document Rescission

EMER 2.4.3 Emergency Plan: Gas Field Personnel Dispatched to Major Leak or Line Break

Section 1.0 Dispatched to Major Leak or Line Break

Document Rescission

EMER 2.4.4 Emergency Plan: Gas Field Personnel Dispatched to Gas in a Sewer Hazardous Condition

Section 1.0 Dispatched to Gas in a Sewer Hazardous Condition

Document Rescission

EMER 2.4.5 Emergency Plan: Gas Field Personnel Dispatched to Gas Related Fire, Ignition, or Explosion

Section 1.0 Dispatched to Gas Related Fire, Ignition, or Explosion

Document Rescission

EMER 2.4.6 Emergency Plan: Gas Field Personnel Dispatched to Non-Gas Related Fire, Ignition, or Explosion

Section 1.0 Dispatched to Non-Gas Related Fire, Ignition, or Explosion

Document Rescission

Revision Notes

EMER 2.4.7 Emergency Plan: Gas Field Personnel Dispatched to Explosion and/or Fire Near Gas Pipeline Facilities

Section 1.0 Dispatched to Explosion and/or Fire Near Gas Pipeline Facilities

Document Rescission

EMER 2.4.8 Emergency Plan: Gas Field Personnel Train Derailment near Pipeline Facilities

Section 1.0 Train Derailment near Pipeline Facilities

Document Rescission

EMER 2.4.9 Emergency Plan: Gas Field Personnel Low-Pressure Situation

Section 1.0 Low-Pressure Situation

Document Rescission

EMER 2.4.10 Emergency Plan: Gas Field Personnel Over-Pressure Situation

Section 1.0 Over-Pressure Situation

Document Rescission

EMER 2.4.11 Emergency Plan: Gas Field Personnel Loss and Restoration of Service

Section 1.0 Loss and Restoration of Service

Document Rescission

EMER 2.5 Emergency Plan: Natural Disasters and Civil Disobedience

Section 1.0 Purpose
Section 2.0 Scope
Section 3.0 Target Audience
Section 4.0 Natural Disasters: Other Than Floods
Section 5.0 Natural Disasters: Floods
Section 6.0 Civil Disobedience
Operator Qualification (OQ)
Compliance Requirements
Reference Documents
Document Rescission

EMER 2.6 Emergency Plan: Emergency Personnel and Materials

Section 1.0 Purpose
Section 2.0 Scope
Section 3.0 Target Audience
Section 4.0 Personnel, Storeroom, Specialized Tools and Equipment
Section 5.0 Emergency Gas Material
Section 6.0 Centralized Emergency Gas Material
Section 7.0 Non-Centralized Emergency Gas Material
Operator Qualification (OQ)
Compliance Requirements
Reference Documents
Document Rescission

EMER 2.7 Emergency Plan: Emergency Response Review

Section 1.0 Purpose
Section 2.0 Scope
Section 3.0 Target Audience
Section 4.0 General
Section 5.0 Written Report
Operator Qualification (OQ)
Appendices
 Appendix A - Sample Emergency Response Review Form
Compliance Requirements

Reference Documents

Document Rescission

EMER 2.8 Emergency Plan: Training

Section 1.0 Purpose

Section 2.0 Scope

Section 3.0 Target Audience

Section 4.0 General

Section 5.0 Initial Training

Section 6.0 Refresher Training

Section 7.0 Verification of Training Effectiveness

Operator Qualification (OQ)

Compliance Requirements

Reference Documents

Document Rescission

EMER 2.9 Emergency Plan: CNG Trailers

Section 1.0 Purpose

Section 2.0 Scope

Section 3.0 Target Audience

Section 4.0 General

Section 5.0 CNG Trailers by Location and Capacity

Section 6.0 Regulating and Relief Equipment

Section 7.0 Other Equipment

Section 8.0 CNG Filling Stations

Section 9.0 CNG Cylinders

Section 10.0 CNG Transportation Requirements

Section 11.0 Using CNG Trailers

Section 12.0 Instructions

Section 13.0 Examples

Operator Qualification (OQ)

Compliance Requirements

Reference Documents

Document Rescission

EMER 2.10 Emergency Plan: Gas Control

Section 1.0 Purpose

UNCONTROLLED IF PRINTED

Section 2.0 Scope
Section 3.0 Target Audience
Section 4.0 General
Section 5.0 Loss of Communications
Section 6.0 Alarm Management
Operator Qualification (OQ)
Compliance Requirements
Reference Documents
Document Rescission
Revision Notes

EMER 2.11 Emergency Plan: Gas Storage

Section 1.0 Purpose
Section 2.0 Scope
Section 3.0 Target Audience
Section 4.0 General
Section 5.0 Accidental Release from an Underground Natural Gas Storage Facility
Section 6.0 Equipment Failures at an Underground Natural Gas Storage Facility
Section 7.0 Natural Disasters
Section 8.0 Third-Part Emergencies
Document Rescission
Revision Notes

EMER 3 Emergency Plan: Forms and Reference Materials

Forms
References
Document Rescission

Operator Qualification (OQ)
Compliance Requirements
Reference Documents

End Table of Contents.

Document Rescission

EMER 0 Emergency Plan Table of Contents, April 1, 2021.

UNCONTROLLED IF PRINTED

Revision Notes

Location of Changes	Summary of Changes
EMER 2.11	New - Gas Storage. Procedures were effective on July 22, 2022.

EMERGENCY PLAN

July 22, 2022

EMER 1 Requirements

1.0 Purpose

This document outlines Ameren Illinois' (AIC's) Emergency Plan in accordance with 49 CFR §192.615.

2.0 Scope

This document addresses the following:

[3.0 Target Audience](#)

[4.0 General](#)

[5.0 Procedures](#)

3.0 Target Audience

- Gas Supervisor
- Gas Field Personnel
- Gas Tech Services (GTS) Supervisors
- Gas Tech Services (GTS) Personnel
- Gas Engineering
- Gas Integrity Management Personnel
- Gas Tech Engineering (GTE)
- Gas Storage Field Personnel
- Public Awareness Personnel
- Gas Control.

4.0 General (§192.615(a)(5), (a)(7), (b)(1))

- 4.1 AIC's highest priority is the safety of the general public, AIC's natural gas customers, and its employees.
- 4.2 AIC's Emergency Plan ensures that people are protected before property.
- 4.3 AIC's Emergency Plan addresses how AIC's Operator Qualified gas personnel evaluate and mitigate emergencies resulting from:
 - 4.3.1 Abnormal operating conditions.
 - 4.3.2 Malfunctions of:
 1. AIC's equipment.
 2. AIC's customer's equipment.
 - 4.3.3 Material defects.
 - 4.3.4 Third party damages.
 - 4.3.5 Natural disasters.
 - 4.3.6 Civil disobedience.
 - 4.3.7 Accidental release of gas from an underground natural gas storage facility.
- 4.4 For every natural gas emergency:
 - 4.4.1 If the caller is from the general public or is one of AIC's customers, AIC shall provide instructions for:

UNCONTROLLED IF PRINTED

1. Moving to a safe place.
 2. Contacting AIC's responder when the responder arrives.
- 4.4.2 If the caller is from a police or fire department or is a public official, AIC shall provide whatever assistance is requested.
- 4.4.3 AIC's response shall be prompt and effective.
- 4.4.4 The situation shall be evaluated professionally and thoroughly.
- 4.4.5 The cause shall be accurately identified.
- 4.4.6 The corrective action shall be thoroughly developed and performed by AIC's Operator Qualified gas personnel.
- 4.4.7 The mitigation measures shall be performed in a safe manner consistent with AIC's Operating and Maintenance Plan (O&M Plan).
- 4.4.8 Service shall be completely and reliably restored to every natural gas customer.
- 4.4.9 AIC's and the customer's gas facilities shall be returned to a safe operating condition.
- 4.4.10 The post review of the emergency action shall determine whether:
1. All safety measures to protect the general public, emergency responders, AIC's customers, and its employees were performed?
 2. Appropriate and timely action was taken?
 3. The cause was accurately identified?
 4. The corrective action was appropriate?
 5. Additional or refresher training is required?
- 4.5 The Emergency Plan is part AIC's O&M Plan. The O&M Plan is:
- 4.5.1 Provided to all supervisory gas personnel, including those responsible for emergency action.
- 4.5.2 Updated periodically and distributed electronically to each supervisor's lap top computer.

5.0 Procedures (§192.615)

Table 1: AIC Compliance with §192.615

	Description of Criteria in §192.615		AIC Procedure
5.1	a	Each operator shall establish written procedures to minimize the hazard resulting from a gas pipeline emergency. At a minimum, the procedures must provide for the following:	
5.1.1	a(1)	Receiving, identifying, and classifying notices of events which	EMER 2.1

		require immediate response by the operator.	
5.1.2	a(2)	Establishing and maintaining adequate means of communication with appropriate fire, police, and other public officials.	PUBL 2.2
5.1.3	a(3)	Prompt and effective response to a notice of each type of emergency, including the following:	
5.1.3.1	a(3)(i)	Gas or gas odors detected inside or near a building.	EMER 2.3 , 2.4
5.1.3.2	a(3)(ii)	Fire located near or directly involving a pipeline facility.	EMER 2.4
5.1.3.3	a(3)(iii)	Explosion occurring near or directly involving a pipeline facility.	EMER 2.4
5.1.3.4	a(3)(iv)	Natural disaster.	EMER 2.5
5.1.4	a(4)	The availability of personnel, equipment, tools, and materials, as needed at the scene of an emergency.	EMER 2.6
5.1.5	a(5)	Actions directed toward protecting people first and then property.	EMER 1 , 2.1 thru 2.5
5.1.6	a(6)	Emergency shutdown and pressure reduction in any section of the operator's pipeline system necessary to minimize hazards to life or property.	EMER 2.4
5.1.7	a(7)	Making safe any actual or potential hazard to life or property.	EMER 1 , 2.3 , 2.4
5.1.8	a(8)	Notifying appropriate fire, police, and other public officials of gas pipeline emergencies	EMER 2.1 , 2.2 , 2.4 PUBL 2.2

UNCONTROLLED IF PRINTED

		and coordinating with them both planned responses and actual responses during an emergency.	
5.1.9	a(9)	Safely restoring any service outage.	EMER 2.4 LEAK 2.1, 2.2 METR 2.1 PURG 2 TURN 1
5.1.10	a(10)	Beginning action under §192.617, if applicable, as soon after the end of the emergency as possible.	INVE
5.1.11	a(11)	Actions required to be taken by a controller during an emergency in accordance with §192.631.	Control Room Management Plan
5.1.12	a(12)	Actions required to be taken by UNGS facility during an emergency in accordance with §192.12.	Gas Storage Emergency Plan
5.2	b	Each operator shall:	
5.2.1	b(1)	Furnish its supervisors who are responsible for emergency action a copy of that portion of the latest edition of the emergency procedures established under paragraph (a) [5.1 - 5.1.11] as necessary for compliance with those procedures.	EMER 1
5.2.2	b(2)	Train the appropriate operating personnel to assure that they are knowledgeable of the emergency procedures and verify that the training is effective.	EMER 2.8
5.2.3	b(3)	Review employee activities to determine whether the procedures were effectively	EMER 2.7

		followed in each emergency.	
5.3	c	Each operator shall establish and maintain liaison with appropriate fire, police, and other public officials to:	
5.3.1	c(1)	Learn the responsibility and resources of each government organization that may respond to a gas pipeline emergency;	PUBL 2.2
5.3.2	c(2)	Acquaint the officials with the operator's ability in responding to a gas pipeline emergency;	PUBL 2.2
5.3.3	c(3)	Identify the types of gas pipeline emergencies of which the operator notifies the officials; and	PUBL 2.2
5.3.4	c(4)	Plan how the operator and officials can engage in mutual assistance to minimize hazards to life or property.	PUBL 2.2

End of Instructions.

Operator Qualification (OQ) Required?

NO.

Appendices

NONE.

Attachments

NONE.

Compliance Requirements

- 49 CFR §192.12: Underground Natural Gas Storage Facilities
- 49 CFR §192.615 Emergency plans.
- 49 CFR §192.617 Investigation of failures.
- 49 CFR §192.631 Control room management.

UNCONTROLLED IF PRINTED

Reference Documents

Control Room Management Plan

[EMER 1 Emergency Plan: Requirements](#)

[EMER 2.1 Emergency Plan: Customer Care Center](#)

[EMER 2.2 Emergency Plan: Dispatch Center](#)

[EMER 2.3 Emergency Plan: Emergency Responder](#)

[EMER 2.4 Emergency Plan: Gas Field Personnel](#)

[EMER 2.5 Emergency Plan: Natural Disasters and Civil Disobedience](#)

[EMER 2.6 Emergency Plan: Emergency Personnel and Materials](#)

[EMER 2.7 Emergency Plan: Emergency Response Review](#)

[EMER 2.8 Emergency Plan: Refresher Training](#)

[EMER 2.11 Emergency Plan: Gas Storage](#)

[INVE Investigation of Incidents](#)

[PUBL 2.2 Public Education: Liaisons with Fire, Police, and Public Officials](#)

Document Rescission

EMER 1 Emergency Plan – Requirements, June 3, 2021

Revision Notes

Location of Changes	Summary of Changes
5.0 Procedures	Added 5.1.12 Gas Storage Emergency Plan
Compliance Re-quirements	Added 49 CFR §192.12 Underground Natural Gas Storage Fa-cilities
Reference Docu-ments	Added EMER 2.11 Emergency Plan: Gas Storage

EMERGENCY PLAN

May 15, 2022

EMER 2.1 Customer Care Center

1.0 Purpose

This document outlines procedures and guidance for Ameren Illinois (AIC) Customer Care Center in accordance with 49 CFR §192.615.

2.0 Scope

This document addresses the following:

[3.0 Target Audience](#)

[4.0 General \(§192.615\(a\)\(1\), \(a\)\(5\)\)](#)

[5.0 Receiving Natural Gas Odor or Leak Call](#)

[6.0 Receiving Request to Cancel Natural Gas Odor or Leak Call](#)

[7.0 Receiving Fire or Explosion Call from Emergency Agencies](#)

[8.0 Receiving Carbon Monoxide Call from Emergency Agencies](#)

[9.0 Receiving Carbon Monoxide Call from General Public or AIC Customer](#)

3.0 Target Audience

- Customer Service Representatives (CSR)

4.0 General (§192.615(a)(1), (a)(5))

4.1 AIC Customer Care Center's Customer Service Representative shall:

4.1.1 Promptly answer all calls.

1. Consider any call about a natural gas odor or leak to be an emergency to which all AIC employees shall give prompt attention.

4.1.2 Gather and record accurate and complete information to assist in a prompt and effective response.

4.1.3 Provide appropriate safety instructions based on information obtained from the caller to ensure the safety of the caller and others.

- Enter an emergency callout order into Call Entry. An emergency callout order is always issued for:
 - Fires.
 - Natural gas alarms.
 - Natural gas odors and leaks.
 - Requests from municipal or emergency response agencies.
 - Troubles with excavation barricades.

- An emergency callout order initiates the immediate dispatch of gas field personnel, an Emergency Responder, or a Gas Supervisor and notice to the appropriate operating area.

UNCONTROLLED IF PRINTED

- Call Entry is used to report, manage, and document customer complaints, gas leak investigations, and response times.

4.1.4 Never cancel a natural gas odor or leak response.

4.1.5 Never charge for an emergency call.

AIC does not want to discourage callers from reporting a possible natural gas emergency because of a possible charge.

4.2 The following sections provide guidance on the type of information the CSR's should obtain and provide when responding to various call situations.

4.3 The Customer Care Center department, with Gas Operations providing oversight, shall develop the actual script as to how CSR's communicate with a caller.

5.0 Receiving Natural Gas Odor or Leak Call

5.1 Record caller information such as:

5.1.1 Caller's name.

5.1.2 Address where problem is occurring.

5.2 Verify the address - repeat to the caller the address showing in the system (house number, street, city, zip code).

5.3 Record a phone number that is away from the location (cell phone is acceptable).

5.4 Verify from caller that property is accessible.

5.5 Ask probing questions to determine the nature of the odor. Caller may provide information such as:

5.5.1 Where gas is smelled, heard, and/or seen - indoors, outdoors, or both.

5.5.2 What is it near?

5.5.3 If gas odor or leak is outdoors:

1. Has there been an accident?
2. Any digging in the area?
3. Is it blowing?

5.6 Before submitting the order, ensure information in Call Entry is accurate and correct.

5.7 See [Subsection 5.11](#) if caller is:

- 911 Dispatcher.
- AIC Meter Reader.
- AMI Meter Installer.
- Customer Survey Agent.
- Leak Surveyor.
- Local Fire, Police.
- Summer Gas Meter Painter.

5.8 For indoor odor or leak - smell, hear, or see:

UNCONTROLLED IF PRINTED

5.8.1 Caller shall be provided with safety instructions such as:

1. Evacuate to a safe distance from the location immediately.
2. Do not operate light switches, thermostats, garage door openers, appliances, or anything that could cause a spark.
3. Do not unplug phone chargers or any other electrical equipment which could cause a spark.
4. Do not light cigarettes, E-cigarettes, matches, candles, or use anything with an open flame.
5. Do not open windows or doors to ventilate.
6. If caller is using a land line phone, set the phone down and do not hang up.
7. If caller is using a cell phone, do not hang up, carry it outdoors, and then hang up when call is finished.
8. Do not re-enter building for any reason until AIC service person announces it is safe to re-enter.
9. Do not wait right outside building but please watch for us from a safe distance either up or down the street.

5.8.2 Caller shall be provided with additional information:

1. We must have access to building for an indoor leak. If no one is present to provide access to the building:
 - 1 a. The gas meter will be turned off and locked.
 - 1 b. When called to unlock the meter, we will complete the indoor portion of a leak investigation.

5.8.3 Continue to [Subsection 5.10](#).

5.9 For outdoor odor or leak - smell, hear, or see:

5.9.1 Caller shall be provided with safety instructions such as:

1. Do not attempt to stop the flow of gas or to squeeze off, plug, or bend the pipe.
2. Do not attempt to backfill a damaged or potentially damaged gas line.
3. Do not operate any vehicle or machinery near the leak.
4. Do not use any device or equipment that could generate a spark or flame.
5. Stay away at a safe distance upwind of the leak and keep others away from source of the leak.
6. If the conditions worsens, such as an ignition or explosion, call 911.
7. If you are already in the building, stay inside and wait for us. However, if an odor is noticed inside while waiting, evacuate to a safe distance upwind of the premise.

5.10 End every call by providing the following information:

- 5.10.1 It is important that someone make contact with the service person upon arrival, or for safety reasons we may have to turn the gas off.

5.10.2 I am issuing an order immediately, please watch for and make contact with the service person who usually arrives within 60 minutes.

5.11 Contact Dispatch Center to verify they received the gas odor callout order.

5.12 If it cannot be determined that the caller is in AIC's service territory:

5.12.1 Process a Non-Customer order with a good address, directions, and phone number.

5.12.2 Contact Dispatch Center to verify they received the Non-Customer order.

6.0 Receiving Request to Cancel Natural Gas Odor or Leak Call

6.1 CSR's shall deny any request to cancel an odor/leak call.

6.2 The reasons a CSR cannot cancel order are:

6.2.1 We are obligated by Illinois Commerce Commission (ICC) rules to proceed to the location to complete an investigation.

6.2.2 Our primary concern is the safety of our customers and by completing a thorough leak investigation we can verify that natural gas is not creating a hazard.

7.0 Receiving Fire or Explosion Call from Emergency Agencies

7.1 AIC shall respond and provide assistance when the police or fire department are on the scene or in route.

7.2 If immediate assistance is requested:

7.2.1 Create a gas emergency order.

7.2.2 Process order with the same priority as a gas leak.

8.0 Receiving Carbon Monoxide Call from Emergency Agencies

8.1 AIC shall respond and provide whatever assistance is requested.

8.2 If immediate assistance is requested:

8.2.1 Create a carbon monoxide order.

8.2.2 Select "Fire/Police checkbox" so Dispatch and field personnel can view the order.

8.2.3 Process order with the priority level 8.

8.3 Enter call information in Call Entry.

8.4 Contact dispatch center to verify they received the Carbon Monoxide order.

9.0 Receiving Carbon Monoxide Call from General Public or AIC Customer

9.1 AIC normally does not respond to general public or customer calls regarding carbon monoxide.

9.2 However, it is extremely important to document calls regarding carbon monoxide.

9.2.1 Enter caller's name, address, and phone number into the system.

9.2.2 Document or record the conversation.

9.3 If call is due to someone feeling ill or a carbon monoxide alarm sounding -

9.3.1 Instruct caller to:

1. Evacuate the location and get fresh air.
2. Call 911 immediately after evacuating.
3. They may need to call a qualified HVAC professional.

9.3.2 Enter "Carbon Monoxide Request" in Call Entry and note actions and advice in remarks.

Table 1: Carbon Monoxide Symptoms

Headache	Shortness of Breath
Dizziness	Confusion
Nausea	Unconsciousness
Fatigue	

9.4 If caller is merely seeking information and has no physical symptoms, carbon monoxide alarms, or other indications of carbon monoxide symptoms -

9.4.1 Give caller advice such as:

1. AIC will mail the company's latest carbon monoxide bill insert.
2. Search the internet for "Carbon Monoxide".

9.4.2 Enter "Carbon Monoxide Request" in Call Entry and note actions and advice in remarks.

End of Instructions.

Operator Qualification (OQ) Required?

NO.

Appendices

NONE.

Attachments

NONE.

Compliance Requirements

49 CFR §192.615 Emergency plans.

Reference Documents

[LEAK 2.1 Leak Management: Indoor Investigations](#)

Document Rescission

EMER 2.1 Emergency Plan – Customer Contact Center, October 1, 2020

Revision Notes

Location of Changes	Summary of Changes
Paragraph 5.10.2	"arrives" replaces "arrived"
Paragraph 6.2.2	Inserted "is" – "primary concern is the safety of our customers"

UNCONTROLLED IF PRINTED

Paragraph 8.2.3 – Emergency Agencies request assistance with CO investiga- tions	Revised – Process the order with priority level 8. The order does not have the same priority level as a gas leak call.
Subsection 8.4	Revised - Contact dispatch center to verify they received the Car- bon Monoxide order, Removed "and that it will be given the same priority as a gas leak"

EMERGENCY PLAN

April 1, 2023

EMER 2.2 Dispatch Center

1.0 Purpose

This document outlines procedures for Ameren Illinois' (AIC's) Dispatch Center in accordance with 49 CFR §192.615.

2.0 Scope

This document addresses the following:

[3.0 Target Audience](#)

[4.0 General](#)

[5.0 Dispatching Gas Field Personnel to Emergency Call](#)

[6.0 Actions Required of Supervisory Personnel](#)

[7.0 Cold Weather Electrical Outages and Restoring Service](#)

3.0 Target Audience

- Gas Distribution System Operating Supervisors (GDSOS)
- Emergency Responders
- Gas Dispatch Superintendent
- Electric Distribution System Operation Supervisors
- Gas Field Personnel
- Gas Planning
- Gas Superintendents
- Gas Supervisors
- Gas Tech Services Supervisor

4.0 General (§192.615(a)(5))

- 4.1 All AIC employees shall consider any Outage Analysis System (OAS) order or call about a natural gas odor or leak to be an emergency that shall be given prompt attention.
- 4.2 Actions shall be directed toward protecting people first and then property.

5.0 Dispatching Gas Field Personnel to Emergency Call

- Per [EMER 2.1](#), a Customer Care Center Representative enters an emergency callout order into OAS. The OAS order is routed to the Gas Dispatch and the appropriate AIC operating area.
 - Upon receipt of the OAS order, a GDSOS immediately sends one of the gas field personnel, an Emergency Responder, or a Gas Supervisor to the location of the emergency and a notice to the appropriate operating area.

- 5.1 Dispatch gas field personnel, Emergency Responders, or Gas Supervisors for investigation of all OAS orders which include:

- Fires.
- Natural gas alarms.
- Troubles with excavation barricades.
- Natural gas odors and leaks.

5.2 Depending on the severity of the problem, time of day, and resources available, the GDSOS shall use one or more of the methods below to ensure a prompt and effective response.

- 5.2.1 Direct contact (radio or cell phone) with gas field personnel working at the time of the call (normal work hours or shift workers).
- 5.2.2 Gas field personnel and Emergency Responders designated for callout.
- 5.2.3 Outlying utilitymen (electric field personnel) near the location of the call.
- 5.2.4 The automated callout application (ARCOS).

ARCOS contains phone lists of gas field personnel and Emergency Responders who are available to respond to a call after normal working hours within the various operating areas.

5.3 If gas field personnel, emergency responders, or Gas Supervisors are unavailable to respond to the call, the GDSOS shall contact the appropriate local police and/or fire department to request assistance.

5.4 During normal working hours, GDSOS are provided with a daily listing of gas field personnel working in the various service centers that should be contacted in cases of emergency.

5.4.1 GDSOS shall attempt to make direct contact with the "assigned" gas field personnel to notify them that an OAS order has been sent to their mobile data terminal (MDT).

5.4.2 If unable to make direct contact, the GDSOS shall contact the appropriate Gas Supervisor.

5.5 GDSOS shall use ARCOS for OAS orders after hours.

5.5.1 If there has not been an acceptance within the amount of time set in ARCOS, the GDSOS shall contact the appropriate Gas Supervisor.

5.6 Once an OAS order is received, the GDSOS shall:

5.6.1 Send a qualified person to the location.

5.6.2 Never cancel an OAS order even if a cancellation is received.

Electric Control has compiled and maintains the 911 numbers for emergency agencies throughout AIC's operating areas. These numbers are used by Distribution Control's interactive phone system. The 911 numbers are reviewed and updated annually with assistance from Public Awareness.

6.0 Actions Required of Supervisory Personnel

- 6.1 When contacted by the GDSOS, supervisory personnel shall assume responsibility for the gas emergency and take prompt action to address the situation.
- 6.2 Supervisory personnel:
- 6.2.1 Shall instruct the GDSOS about additional steps to take including:
1. Continue calling qualified gas field personnel using ARCOS.
 2. Call a qualified Gas Supervisor.
 3. Call qualified Emergency Responders (gas apprentices, electric field personnel, meter changers, Gas Supervisors, etc.).
 4. Call the fire and/or police department.
- 6.2.2 May elect to drive to the site and if Operator Qualified, respond to the emergency call. See [EMER 2.4](#).

The response may include:

- Turning off the gas outside the structure.
- Electing to evacuate the structure involved or even surrounding structures if the situation warrants.
- Performing an official "gas leak investigation" only if Operator Qualified for leak investigation and the required equipment is available.

7.0 Cold Weather Electrical Outages and Restoring Service

- 7.1 Electric Distribution Controls responsible for handling any cold weather electrical outages and restoring electrical service to AIC's customers.
- 7.1.1 Cold weather restoration of electrical service after an extended outage can create a situation where instantaneous gas load can exceed the capacity of the affected gas systems.
- 7.1.2 In this situation, it is possible for the gas system to experience operating pressures well below their designated setpoints, resulting in a potential gas outage for AIC's customers.
- 7.1.3 Conditions identified that will enact the Electric Cold Load Restoration Policy, refer to [EMER 3](#) for the policy.
1. Ambient temperature: 20 °F or less at the location of outage. AND
 2. Duration of the electrical outage: in excess of 4 hours.
 3. High Risk Gas Systems have been identified for pressure monitoring and/or electric circuit segmentation during restoration efforts. These high-risk Gas Systems are located in the ElectricColdLoadPickup.xlsx file.
- 7.2 When determined by the Distribution System Operations Supervisor (DSOS) that an electric outage exists over an identified Gas System and will exceed both of the thresholds identified in the Electric Cold Load Restoration Policy, see [EMER 3](#), the DSOS will inform the appropriate Gas Tech Services (GTS) Supervisor and Gas Control of the electric outage.

- 7.2.1 Electric restoration for the affected circuits will be coordinated with GTS, based on the risk level of the affected gas system listed in the ElectricColdLoadPickup.xlsx file.
- 7.2.2 GTS shall also be notified of scheduled maintenance outages and outages involving activation of the Emergency Operation Center (EOC).

7.3 Contact Lists for Gas Tech Services (GTS) and Gas Planning Groups

Table 1: Gas Tech Support Contact Information

Region	Title	Contact	Cell Phone	Office Phone
	Director	Gene Eagle	217-412-6432	217-424-6542
NORTH (GAL, KEW, LAS EST, LAC, PEK, PEO, WES)	Supervisor	Rick Dougherty	309-335-4870	309-335-4870
	Superintendent	Kelly Coppernoll	309-264-4250	309-677-7580
NORTH (SPI, LIC, DEC)	Supervisor	Ian Carter	217-671-2664	217-753-5163
	Superintendent	Kelly Coppernoll	309-264-4250	309-677-7580
WEST (BRD, CAN, JCK, JER, MCB, PET, QCY)	Superintendent	Gary Vaughn	217-341-1638	217-479-5232
	Back-up	Chris Logan	618-401-4364	618-343-4913
WEST (ALT, GRC, HIL, MRY, RVB)	Supervisor	Chris Logan	618-401-4364	618-343-4913
	Superintendent	Gary Vaughn	217-341-1638	217-479-5232
EAST (CMP, DAN, EFF, MAT, PAN, PAX, PAR, ROB, TSC, TUS)	Supervisor	Jason Dirks	217-751-2036	217-403-4105
	Superintendent	Kelly Coppernoll	309-264-4250	309-677-7580
SOUTH (BEL, ESL, SPA, CBD, CNT, MAR, MTV)	Supervisor	Matt Klopmeier	618-578-9298	618-482-2258
	Superintendent	Gary Vaughn	217-341-1638	217-479-5232

Table 2: Gas Planning Contact Information

Cell phone is preferred contact method. Office number available through Co-Worker Connect.

<u>Region</u>	Contact	Supervising Engineer
NORTH (GAL, KEW, LAS)	Nate Thomas C- 309-264-4968	John Kaczmarek C- 217-329-4250
NORTH (EST, LAC, PEK, PEO, WES)	Nate Thomas C- 309-264-4968	

UNCONTROLLED IF PRINTED

NORTH (SPI, LIC)	Jon Lutes C- 217-412-6437
NORTH (DEC)	Mike Fitzgerald C- 309-323-8223
WEST (BRD, CAN, JCK, JER, MCB, PET, QCY)	Jon Lutes C- 217-412-6437

Region	Contact	Supervising Engineer
WEST (ALT, GRC, HIL, MRY, RVB)	Swan Joslin C- 618-365-1364	John Kaczmarek C- 217-329-4250
EAST (CMP, DAN, EFF, MAT, PAN, PAX, PAR, ROB, TSC, TUS)	Mike Fitzgerald C- 309-323-8223	
SOUTH (BEL, ESL, SPA)	Swan Joslin C- 618-365-1364	
SOUTH (CBD, CNT, MAR, MTV)	Joe Weissert C- 618-402-7200	

End of Instructions.

Operator Qualification (OQ) Required?

YES

A003: Emergency Response

Appendices

UNCONTROLLED IF PRINTED

NONE.

Attachments

NONE.

Compliance Requirements

49 CFR §192.615. Emergency plans.

Reference Documents

[EMER 2.1 Customer Care Center](#)

[EMER 2.4 Emergency Plan: Gas Field Personnel](#)

[EMER 3 Emergency Plan: Forms and Reference Materials](#)

[OQAL 2.01 Operator Qualification: Covered Task List](#)

Document Rescission

EMER 2.2 Emergency Plan: Dispatch Center, October 1, 2022

Revision Notes

Location of Changes	Summary of Changes
Subsection 7.3 – Gas Planning	Update contact information for Gas Planning. Removed all of the Gas Planning Backup Contacts

EMERGENCY PLAN

May 15, 2022

EMER 2.3 Emergency Responder

1.0 Purpose

This document outlines procedures for Ameren Illinois' (AIC's) Emergency Responders in accordance with 49 CFR §192.615.

2.0 Scope

This document addresses the following:

[3.0 Target Audience](#)

[4.0 General](#)

[5.0 Dispatched to Indoor Odor or Leak](#)

[6.0 Dispatched to Outdoor Odor or Leak](#)

[7.0 Dispatched to Cut Main or Service](#)

3.0 Target Audience

- Dispatchers
- Emergency Responders
- Gas Apprentices
- Gas Field Personnel
- Gas Supervisors
- Gas Engineering

4.0 General (§192.615(a)(5))

4.1 When responding to an emergency, Emergency Responders shall give the safety of the public and AIC's customers and employees top priority. Actions shall be directed to protect people first, then property.

4.2 AIC trains, tests, and operator qualifies non-gas field personnel and/or gas apprentices as Emergency Responders for gas emergency calls. Non-gas field personnel may include:

- Electric Field Personnel.
- Gas Apprentices
- Gas Supervisors.
- Meter Changers.
- Meter Readers.

4.3 On occasion, a qualified Emergency Responder will be dispatched in response to gas leak/odor call to perform "make safe" procedures until qualified gas field personnel can respond and investigate the leak.

4.4 Emergency Responders shall follow the procedures below.

5.0 Dispatched to Indoor Odor or Leak (§192.615(a)(3)(i), (a)(7))

- A Customer Care Center Representative has instructed the caller to:

UNCONTROLLED IF PRINTED

- Evacuate the structure.
- Move a safe distance away from the structure.
- Make contact with the first arriving AIC service person.

5.1 Park on the street or in a safe location.

- Avoid parking directly in front of a structure involved in the emergency.
- Avoid parking over manholes as they may be within the gas leak migration pattern and could possibly be venting.
- Avoid parking over main valves if they are required for make safe action.

5.2 Approach by walking toward a corner of the structure.

5.3 Protect people:

5.3.1 Keep occupants at a safe distance until a qualified gas field person arrives and determines when it is safe to re-enter the structure.

For a safe distance, consider:

- In a town or city setting, moving 2 or 3 houses or buildings away.
- In a rural setting, moving 100 to 200 feet from the affected structure or area.

5.3.2 Ask the occupants where they smelled the gas odor.

5.3.3 If occupants have not evacuated:

1. Knock on the door (NEVER use the doorbell or intercom).
2. Show AIC identification.
3. Tell the occupants to evacuate immediately.
 - 3 a. Contact or have dispatch contact fire department and request assistance with evacuation of a:
 - Multi-family structure.
 - Structure containing a large number of people such as a:
 - School.
 - Nursing home.
 - Manufacturing facility.
 - Hospital.
 - Commercial business.
4. Tell the evacuees:

UNCONTROLLED IF PRINTED

- 4 a. Do not touch anything.
5. Direct them to a safe location (see safe distance note) away from the structure until it is safe to re-enter the structure.
6. Count the occupants as they exit and notify the Dispatcher or Gas Supervisor of the total count.
7. Leave the structure if no further indoor tasks are to be performed.

5.4 Protect property:

5.4.1 Before touching the gas meter set:

CAUTION

The flashlight on the volt stick is not intrinsically safe and shall be left off when a hazardous condition exists (e.g. during indoor or outdoor leak investigations).

1. Check meter and customer fuel line with volt stick.



Figure 1: Typical Volt Stick

- 1 a. Volt stick alarms: see [METR 2.2 Section 7.0](#) Meter Header Inspection. Then see [Subparagraph 2](#).
- 1 b. No volt stick alarm: see Subparagraph 2.
2. Check service riser with volt stick.
 - 2 a. Volt stick alarms: *do not shut-off meter valve*. See [Subsection 5.5](#).
 - 2 b. No volt stick alarm: see Paragraph 5.4.2.
- 5.4.2 Verify the meter number if customer is not present.
- 5.4.3 Observe test hand for movement.

Movement of test hand implies gas flow.

- 5.4.4 Shut off meter valve or customer valve.
- 5.5 Stay on site with the occupants at a safe distance (see [safe distance note](#)) until qualified gas field personnel arrive.
- 5.6 When qualified gas field personnel arrive, update them about the occupants, the meter, where the occupants smelled the gas odor, and any other concerns.
- 5.7 Once the qualified gas field personnel take over the situation, the Emergency Responder is released *unless* the qualified gas field personnel request their assistance.

6.0 Dispatched to Outdoor Odor or Leak (§192.615 (a)(3)(i), (a)(7))

- A Customer Care Center Representative has instructed the caller:
 - If already outdoors, stay a safe distance upwind of the odor or source of the leak and make contact with the first arriving AIC service person.
 - If already indoors, stay indoors and make contact with the first arriving AIC service person.
 - If already indoors and notice an odor INDOORS while waiting, evacuate the building, stay a safe distance upwind of the odor or source of the leak, and make contact with the first arriving AIC service person.

6.1 Park in a safe location upwind of the outdoor odor or leak. Also see [parking caution](#).

6.2 Approach the odor or leak from the upwind location.

6.3 Protect people:

6.3.1 Keep people upwind and at a safe distance away from the odor or leak. See [safe distance note](#).

6.3.2 Keep ignition sources including vehicles away from the odor or leak.

6.4 Protect property:

6.4.1 If there is a strong odor of gas at the meter, shut off the meter valve in accordance with [Subsection 5.4](#).

6.5 Follow through with Subsections [5.5](#), [5.6](#), and [5.7](#).

7.0 Dispatched to Cut Main or Service (§192.615(a)(7))

7.1 Park on the street or in a safe location upwind of the outdoor leak. Also see [parking caution](#).

7.2 Approach the leak from an upwind location.

7.3 Maintain a minimum 20-foot radius safety zone from the cut main or service in accordance with [WIGE 2.1 Subsection 6.3](#).

7.4 Keep excavators, emergency response personnel, and the general public at a safe distance upwind of the leak. See [safe distance note](#).

7.5 Stay on site until qualified gas field personnel arrive.

7.6 Update the gas field personnel about actions that have been taken.

End of Instructions.

Operator Qualification (OQ) Required?

YES

A003: Emergency Response

UNCONTROLLED IF PRINTED

1201: Disconnect Customer Services

Appendices

NONE.

Attachments

NONE.

Compliance Requirements

49 CFR §192.615 Emergency plans.

Reference Documents

[METR 2.2 Metering: Meter Inspection & Testing](#)

[OQAL 2.01 Operator Qualification: Covered Task List](#)

[WIGE 2.1 Working In Gaseous Environment: Hazardous Environment](#)

Document Rescission

EMER 2.3 Emergency Plan – Emergency Responder, April 1, 2021

Revision Notes

Location of Changes	Summary of Changes
Section 6.0 Note	Customer Care Center replaces Call Care Center

EMER 2.4 Gas Field Personnel

EMERGENCY PLAN

October 1, 2022

EMER 2.4 Gas Field Personnel General

1.0 Purpose

The EMER 2.4 documents outline procedures for Ameren Illinois' (AIC's) gas field personnel responding to emergency situations in accordance with 49 CFR §192.615. This document provides general procedures supporting the EMER 2.4 documents.

2.0 Scope

This document addresses the following:

[3.0 Target Audience](#)

[4.0 General](#)

Appendices:

[Appendix A - OAS 6H Screen Shot: Meter Valve Shut Off and Red Pin](#)

3.0 Target Audience

- Gas Control Personnel
- Gas Field Personnel
- Gas Supervisors
- Gas Control
- Gas Tech Services (GTS) Supervisors
- Gas Tech Service (GTS) Personnel
- Gas Integrity Management Personnel
- Gas Engineering

4.0 General (§192.615(a)(5), (a)(7))

4.1 When responding to an emergency, gas field personnel shall give the safety of the public and AIC's customers and employees top priority. Actions shall be directed to protect people first, then property.

4.2 *Before touching the gas meter set:*

The flashlight on the volt stick is not intrinsically safe and shall be left off when a hazardous condition exists (e.g. during indoor or outdoor leak investigations).

4.2.1 Check the meter, riser and customer fuel line with volt stick.



Figure 1: Typical Volt Stick

UNCONTROLLED IF PRINTED

1. Volt stick alarms: see [METR 2.2 Section 7.3](#) AC Voltage Action Table
 2. Volt stick alarms on riser: do not shut-off meter valve.
 3. No volt stick alarm: see Paragraph 4.2.2.
- 4.2.2 Verify the meter number if customer is not present.
- 4.2.3 Observe the test hand for movement.

Movement of the test hand implies gas flow.

- 4.2.4 If there is rapid movement of the test hand, shut off meter valve or customer valve.
- 4.3 Do not use a Flame Ionization (FI) unit for indoor leak investigations.
- 4.4 Ensure the Combustible Gas Indicators (CGIs) have been calibrated and checked. See [LEAK 2.5](#).
- 4.5 Evacuate occupants of homes, buildings, and structures as follows:
- 4.5.1 Knock on the door (NEVER use the doorbell or intercom).
 - 4.5.2 Show AIC identification.
 - 4.5.3 Ask the occupants to leave immediately.
 - 4.5.4 Instruct them:
 1. Do not touch anything.
 2. Do not operate any electrical switches.
 3. Do not use any electronic devices.
 4. Do not use an elevator.
 - 4.5.5 Direct them to a location that is a safe distance away from the affected structure until it is safe to re-enter the structure.

For a safe distance, consider:

- In a town or city setting, moving 2 or 3 houses or buildings away.
- In a rural setting, moving 100 to 200 feet from the affected structure or area.

- 4.5.6 Ask the occupants where they smelled the gas odor or heard the leak.
 - 4.5.7 Count the occupants as they exit and notify the Dispatcher or Gas Supervisor of the total count.
 - 4.5.8 Leave the structure if no further indoor tasks are to be performed.
- 4.6 After the emergency has been evaluated, isolate the leak using the methods below appropriate to the extent of the emergency. See the following example, then see [Paragraph 4.6.2](#).

UNCONTROLLED IF PRINTED

- 4.6.1 Example: If gas migration is creating an immediate hazard, it may be prudent to use emergency valves rather than excavating and squeezing pipe to reduce the immediate hazard.

If a non-emergency valve is used to isolate or sectionalize gas main segments during an emergency, designate the valve as an Emergency Valve after the emergency has been resolved. See [VALV 2.1](#).

- 4.6.2 Use emergency valves, when appropriate,

Or

- 4.6.3 Squeeze plastic or steel pipe (squeezed section of steel pipe will have to be cut-out and replaced before pipeline is reinstated),

Or

- 4.6.4 Use control fittings,

Or

- 4.6.5 Construct a by-pass around damaged area and isolate damaged section.

- 4.7 Park on the street or in a safe location.

- Avoid parking directly in front of a structure involved in the emergency.
- Avoid parking over manholes as they may be within the gas leak migration pattern and could possibly be venting.
- Avoid parking over main valves if they are required for make safe action.

- 4.8 If Gas Control verifies the affected system is remotely monitored, establish a line of communications for the purposes of:

- 4.8.1 Keeping them updated on status of situation.

- 4.8.2 Requesting their assistance in monitoring.

- 4.8.3 Determining at what point Gas Control should issue a warning of potential system problem.

- 4.8.4 Notifying Gas Control when the situation has been corrected and the system should be back to normal operation. Verifying that monitored operating parameters have been restored.

- 4.9 Contact information for individuals in Gas Operations and Services, Gas Control, or Distribution Control is maintained in [FORW](#).

End of Instructions.

Operator Qualification (OQ) Required?

UNCONTROLLED IF PRINTED

YES

A003: Emergency Response

1201: Disconnect Customer Services

1371: Operate Gas Pipeline - System Control Center Operations

Appendices

[Appendix A - OAS 6H Screen Shot: Meter Valve Shut Off and Red Pin](#)

Attachments

NONE.

Compliance Requirements

49 CFR §192.615 Emergency plans.

Reference Documents

[EMER 2.3 Emergency Plan: Emergency Responder](#)

[EMER 2.9 Emergency Plan: CNG Trailers](#)

[EMER 3 Emergency Plan: Forms and Reference Materials](#)

[FORW Forward](#)

[INCD Incident Reporting](#)

[INVE Investigation of Incidents](#)

[LEAK 2.1 Leak Management: Indoor Investigations](#)

[LEAK 2.2 Leak Management: Outdoor Investigations](#)

[LEAK 2.5 Leak Management: Leak Survey Equipment](#)

[METR Metering](#)

[METR 2.1 Metering: Replacement and Retirement](#)

[METR 2.2 Metering: Meter Inspection and Testing - Field](#)

[OQAL 2.1 Operator Qualification: Covered Task List](#)

[PRES 2.1 Pressure Monitoring: Potential Over Pressurization or Service Interruption](#)

[PURG Purging](#)

[PURG 2 Purging: Methods](#)

[RNST Reinstating of Facilities](#)

[TURN Turn-On - Turn-Off](#)

[VALV 2.1 Valves: Valve Installation](#)

[WIGE 2.1 Working In Gaseous Environment: Hazardous Environment](#)

Document Rescission

EMER 2.4 Emergency Plan – Gas Field Personnel, October 1, 2021

Revision Notes

UNCONTROLLED IF PRINTED

Location of Changes	Summary of Changes
Paragraph 4.2.1	Grammatical – Check the meter, riser, and customer fuel line with volt stick
Paragraph 4.2.1 – Item 1.	Updated link – Volt stick alarms: See METR 2.2 Subsection 7.3 AC Voltage Action Table.
Paragraph 4.2.1 – Item 2.	Move from Paragraph 4.2.2 – Volt stick alarms on riser, do not shut off gas meter.

Appendix A - OAS 6H Screen Shot: Meter Valve Shut Off and Red Pin

(See EMER [2.4.5](#) and [2.4.6](#))

```

DSPLY 6H      KEY
*** POAAS06H ***** 29-6H GAS HAZARDOUS CONDITIONS ***** 20167 12:07 ** 50
ACCT NO: 1673573457          PREMISE: 177109873
NAME...: DONALD MCDUFFEE
SERV...: 104 E BOND ST

CITY/ST: BONDVILLE IL      ZIP: 61815      SVC: DTU
*****
AC STA DT HAZARDOUS CONDITION      DESCRIPTION      ST OAS ORD # EMP #
_ 061520 GL GAS LEAK      LEAK ON INLINE VALVE TO WHTR      201671742 C43050
_
_
_
_
_
_
_
_
_
_
_
_
_
_
_
_
OAS ORDER: 201671742          ALL HAZARD INFO COMPLETE? Y/N Y
PF1=HELP PF2=TOP PF3=MAIN MENU PF5=STICKY PF7/8=UP/DOWN
OA286 ORDER IS CANCELLED, CLOSED, EXPORTED, OR RESTORED

TTI
    
```

EMERGENCY PLAN

April 1, 2021

EMER 2.4.1 Gas Field Personnel Dispatched to Indoor Odor or Leak

1.0 Dispatched to Indoor Odor or Leak (§192.615(a)(3)(i), (a)(7), (a)(8))

- An Emergency Responder may already be onsite.
 - A Customer Care Center Representative has instructed the caller to:
 - Evacuate the structure.
 - Move a safe distance away from the structure.
 - Make contact with the first arriving AIC service person.

- 1.1 For parking considerations, see **CAUTION** under [EMER 2.4 Subsection 4.7](#).
- 1.2 Approach by walking toward a corner of the structure.
- 1.3 If an Emergency Responder is NOT onsite, see [Subsection 1.5](#).
- 1.4 Ask Emergency Responder for updates on:
 - 1.4.1 Have occupants evacuated?
 - 1.4.2 Is location of odor or leak known?
 - 1.4.3 Has the meter valve been turned off?
- 1.5 Have the occupants evacuated the structure?
 - 1.5.1 If occupants have evacuated:
 1. Ensure that occupants are a safe distance (see **NOTE** under [EMER 2.4 Paragraph 4.5.5](#)) from the structure until it is safe to re-enter the structure.
 2. Ask the occupants where they smelled the gas odor or heard the leak.
 3. See Subsection 1.6.
 - 1.5.2 If occupants have NOT evacuated, evacuate the occupants. See [EMER 2.4 Subsection 4.5](#).
- 1.6 Sample the ambient atmosphere at the entrance of and throughout the structure with CGI:
 - 1.6.1 Set on the LEL scale.
 - 1.6.2 Intake held as high as possible.
- 1.7 If CGI shows:
 - 1.7.1 10% LEL (0.5% gas in air) or greater:
 1. **A hazardous condition exists.**
 2. See [Subsection 1.8](#).
 - 1.7.2 Less than 10% LEL (less than 0.5% gas in air). See [LEAK 2.1](#).

UNCONTROLLED IF PRINTED

- 1.8 Contact AIC's Dispatcher and/or Gas Supervisor, provide an update of the situation, and request:
 - 1.8.1 Additional assistance from AIC.
 - 1.8.2 Calls be made to proper authorities such as Fire Department, Police Department, electric and other affected utilities, etc.
- 1.9 Shut off the gas from outside the structure if possible. See [EMER 2.4 Subsection 4.2](#) before touching the gas meter valve for shut off.
 - 1.9.1 Verify the meter number if customer is not present.
 - 1.9.2 Observe the test hand for movement. Movement implies gas flow.
 - 1.9.3 Note any movement of the test hand, then shut off the meter valve.
- 1.10 Evacuate surrounding structures that could be impacted in case of an explosion. See [EMER 2.4 Subsection 4.5](#).
- 1.11 Check for gas concentrations at entrances of these structures.
- 1.12 Eliminate as many ignition sources as possible without being exposed to danger.
- 1.13 Check for presence of alternative source of electricity, such as stand-by generator, solar panels, energy storage devices, or wind generators.
 1. If it can be safely done, disconnect these sources. This may require disconnecting at the device.
 2. Customers may be able to provide additional information regarding alternative sources of energy.
- 1.14 Have the electric source, telephone, and cable disconnected from their external sources.
 - 1.14.1 The electric source shall be disconnected at the power pole or transformer away from the structure.

Shutting electricity off at the Advanced Metering Infrastructure (AMI) meter does not satisfy Paragraph 1.14.1 since the switching action in the AMI meter can create a spark.

- 1.14.2 If possible, cut the telephone line at a point away from the structure.
- 1.14.3 If not possible, cut or disconnect the telephone line at the junction box:
 1. Check the junction box on the structure for possible concentration of gas.
 2. If safe, cut or disconnect the telephone line at the junction box.
 3. If not safe, ventilate until safe, then cut or disconnect the telephone line at the junction box.
- 1.15 Ventilate the structure only after external ignition sources have been disconnected.
- 1.16 While the structure is ventilating, check for gas in surrounding structures.
 - 1.16.1 Check for gas concentrations inside and under the structure.
 - 1.16.2 Bar hole test or leak survey around foundation.

UNCONTROLLED IF PRINTED

1.16.3 Check for gas concentrations inside the structure.

1.17 Bar hole test or leak survey surrounding mains and service lines.

1.17.1 If gas is found, complete the leak investigation procedures. See [LEAK 2.2](#).

1.17.2 If gas is found in sewers or conduits, have manhole covers and/or utility access covers removed. See [EMER 2.4.4](#).

1.18 Once it is determined that a hazardous condition no longer exists, complete the leak investigation procedures. See [LEAK 2.1](#).

End of Instructions.

Document Rescission

EMER 2.04 Emergency Plan: Gas Field Personnel, April 1, 2020.

Revision Notes

Location of Changes	Summary of Changes
Subsection 1.13	Added energy storage devices and wind generators as potential alternative sources of electricity. Added note that disconnect may be required at the device and customers may have additional information.

EMERGENCY PLAN

October 1, 2020

EMER 2.4.2 Gas Field Personnel Dispatched to Outdoor Odor or Leak**1.0 Dispatched to Outdoor Odor or Leak (§192.615(a)(3)(i), (a)(7), (a)(8))**

- An Emergency Responder may already be onsite.
- A Customer Care Center Representative has instructed the caller:
 - If already outdoors, stay a safe distance upwind of the odor or source of the leak and contact the first arriving AIC service person.
 - If already indoors, stay indoors and contact the first arriving AIC service person.
 - If already indoors and notice an odor INDOORS while waiting, evacuate the building, stay a safe distance upwind of the odor or source of the leak, and contact the first arriving AIC service person.

- 1.1 Park upwind of the outdoor odor or leak. For additional parking considerations, see **CAUTION** under [EMER 2.4 Subsection 4.7](#).
- 1.2 Approach the odor or leak from the upwind location.
- 1.3 If an Emergency Responder is NOT onsite, see [Subsection 1.5](#).
- 1.4 Ask Emergency Responder for updates on:
 - 1.4.1 Have occupants evacuated?
 - 1.4.2 Is location of odor or leak known?
 - 1.4.3 Has the meter valve been turned off?
- 1.5 Have the occupants evacuated the affected area?
 - 1.5.1 If occupants have evacuated:
 1. Ensure that occupants are a safe distance (see **NOTE** under [EMER 2.4 Paragraph 4.5.5](#)) from the affected area until it is safe to re-enter any structures.
 2. Ask the occupants where they smelled the gas odor or heard the leak.
 3. See [Subsection 1.6](#).
 - 1.5.2 If occupants have NOT evacuated, evacuate the occupants. See [EMER 2.4 Subsection 4.5](#).
- 1.6 Sample the open atmosphere and if CGI shows:
 - 1.6.1 30% LEL (1.5% gas in air) or greater, and:
 - 1.6.2 Gas could enter a structure, or

UNCONTROLLED IF PRINTED

1.6.3 An ignition source is in close proximity, then

1. **A hazardous condition exists.**

2. See [Subsection 1.11](#).

1.6.4 Less than 30% LEL (less than 1.5% gas in air). See [LEAK 2.2](#).

Until a blowing gas situation has been evaluated, the lone gas field person must continuously focus on the following starred (★) tasks.

★1.7 Keep the affected area evacuated.

★1.8 Continue to monitor gas concentration with CGI including surrounding buildings. Evacuate as required. If required, see [EMER 2.4 Subsection 4.5](#).

★1.9 Keep excavators, emergency response personnel, and the general public at a safe distance upwind of the affected area. For safe distance considerations, see **NOTE** under [EMER 2.4 Paragraph 4.5.5](#).

★1.10 Ensure no vehicular equipment is operated within the affected area.

★1.11 Contact AIC's Dispatcher and/or Gas Supervisor, provide an update of the situation, and request:

1.11.1 Additional assistance from AIC.

1.11.2 Calls be made to proper authorities such as Fire Department, Police Department, electric and other utilities, etc.

★1.12 Eliminate as many ignition sources as possible without being exposed to danger.

★1.13 If the leak was caused by excavation or boring damage, investigate for the possibility of multiple leaks (i.e., service pulled out of tee) and gas migration into conduits, sewer lines and adjacent structures.

★1.14 If gas is detected in sewers or conduits, have manhole covers and/or utility access covers removed. See [EMER 2.4.4](#).

★1.15 Check adjacent structures for gas migration.

1.15.1 Check for gas concentrations inside the structure(s).

1.15.2 Bar hole test or leak survey around the foundations.

1.16 After the emergency has been evaluated, see [EMER 2.4 Subsection 4.6](#) to isolate the leak.

1.17 After determining that a hazardous condition no longer exists, complete the leak investigation procedures. See [LEAK 2.2](#).

End of Instructions.

Document Rescission

UNCONTROLLED IF PRINTED

EMER 2.04 Emergency Plan: Gas Field Personnel, April 1, 2020.

Revision Notes

Location of Changes	Summary of Changes
Not applicable.	This is a new document.

EMERGENCY PLAN

October 1, 2022

EMER 2.4.3 Gas Field Personnel Dispatched to Major Leak or Line Break

1.0 Dispatched to Major Leak or Line Break (§192.615(a)(3)(i), (a)(7), (a)(8), (a)(9))

The following steps outline the actions for AIC's first responding field gas personnel and the Gas Supervisor (see Subsection 1.12).

- 1.1 Park upwind of the incident site. For additional parking considerations, see **CAUTION** under [EMER 2.4 Subsection 4.7](#).
- 1.2 Approach the incident site from the upwind location.
- 1.3 Evaluate the situation and take appropriate measures to protect public safety and property, if necessary.
- 1.4 If local emergency response agency:
 - 1.4.1 Has already set up an Incident Command Center (ICS) at the incident site, see [Subsection 1.10](#).
 - 1.4.2 Arrives later and sets up an ICS at the incident site, see [Subsection 1.11](#).
 - 1.4.3 Has not arrived at the incident site, see Subsection 1.5.
- 1.5 AIC's first responding field gas personnel will serve as Incident Commander, and evaluate the situation beginning at Paragraph 1.5.1.
 - 1.5.1 If the leak or line break is freely blowing:
 1. Maintain a safe zone from the blowing gas in accordance with [WIGE 2.1 Section 6.0](#) Safe Zone.
 2. Secure the area with warning signs or warning tape.
 3. Evaluate if the blowing gas has the potential of:
 - 3 a. Entering a structure.
 - 3 b. Coming in contact with an ignition source such as overhead power lines, traffic.
 - 1.5.2 Determine where gas is migrating and if it is creating an immediate hazard to people or property.
 1. Check for gas migration into adjacent structures.
 - 1 a. Use a CGI for indoor gas concentrations.
 - 1 b. Bar hole test or leak survey around the foundations.
 - 1 c. Evacuate structures where indoor gas is detected. See [EMER 2.4 Subsection 4.5](#).
 2. Check for gas migration into sewer lines, catch basins, conduits, and other underground facilities.
 - 2 a. Use a CGI to check for gas concentrations.

UNCONTROLLED IF PRINTED

3. If the leak was caused by damage from excavation or boring, additional investigation is required.
 - 3 a. Check for multiple leaks (i.e., service lines pulled out of tees).
4. Bar hole test or leak survey surrounding mains and service lines.
- 1.5.3 Report the observations and information gathered in [Paragraph 1.5.2](#) to the appropriate Gas Supervisor or Dispatcher and request:
 1. Additional assistance from AIC.
 2. Calls be made to proper authorities such as Fire Department, Police Department, electric and other affected utilities, etc., if applicable.
- 1.6 Until additional help arrives:
 - 1.6.1 Continue to monitor gas concentration with the CGI.
 - 1.6.2 Keep the affected area evacuated.
 - 1.6.3 Keep excavators, emergency response personnel, and the general public at a safe distance upwind of the affected area. For additional safe distance considerations, see **NOTE** under [EMER 2.4 Paragraph 4.5.5](#).
 - 1.6.4 Ensure no vehicular equipment is operated within the affected area.
 - 1.6.5 Eliminate as many ignition sources as possible without being exposed to danger.
- 1.7 When additional gas field personnel arrive, have them:
 - 1.7.1 Assist in identifying the extent of gas migration.
 - 1.7.2 Assist with monitoring the safe zone atmosphere.
 - 1.7.3 If gas was detected in sewers or conduits, have manhole covers and/or utility access covers removed. See [EMER 2.4.4](#) Gas Field Personnel Dispatched to Gas in a Sewer Hazardous Condition.
- 1.8 When help from electric and other affected utilities arrive:
 - 1.8.1 Have the electric source, telephone, and cable disconnected from their external sources.
- 1.9 See [Subsection 1.13](#).
- 1.10 If local emergency responders have already set up an ICS at the incident site :
 - 1.10.1 AIC's first responding gas field personnel shall introduce themselves to the Incident Commander as the representative from AIC; and
 - 1.10.2 Remain the point of contact until the incident has been made safe or until relieved of that duty by another AIC representative; and
 - 1.10.3 Begin emergency response work at [Paragraph 1.5.1](#) and continue through [Subsection 1.8](#).
- 1.11 If local emergency responders arrive later and set up an ICS at the incident site :
 - 1.11.1 AIC's Incident Commander shall introduce themselves as the point of contact for AIC, brief the local Incident Commander; and
 - 1.11.2 Remain the point of contact until the incident has been made safe or until relieved of that duty by another AIC representative; and

UNCONTROLLED IF PRINTED

- 1.11.3 Begin emergency response work at [Paragraph 1.5.1](#) and continue through [Sub-section 1.8](#).
- 1.12 Gas Supervisor or designee shall:
 - 1.12.1 In conjunction with the Gas Superintendent and Gas Control,
 - 1. Determine the consequences and necessity of an immediate shutdown.
 - 2. Consider whether to implement [EMER 2.4.11](#), Gas Field Personnel Loss and Restoration of Service.
 - 3. Consider the temporary use of CNG Trailers. See [EMER 2.9](#).
 - 1.12.2 Contact Gas Control to determine or verify if the affected gas system is being remotely monitored and advise them of the situation and possible actions that may be taken.
 - 1.12.3 Contact Gas Tech Services if transmission or high-pressure distribution facilities are involved.
 - 1.12.4 Develop a communication schedule with Gas Control if Gas Control verifies they are monitoring the affected system and/or facilities through SCADA or installed ERX's. See [EMER 2.4 Subsection 4.8](#).
- 1.13 After the emergency has been evaluated, see [EMER 2.4 Subsection 4.6](#) to isolate the leak.
- 1.14 See [EMER 2.4 Subsection 4.2](#) before shutting off all individual meters in affected area while the repair is taking place.
- 1.15 After the repairs are complete, purge the system of air and relight all affected customers. See [PURG 2](#) and [TURN](#).

End of Instructions.

Document Rescission

EMER 2.4.3 Gas Field Personnel – Major Leak or Line Break, October 1, 2021

Revision Notes

Location of Changes	Summary of Changes
Paragraph 1.5.1 – Item 1.	Revised – Maintain a safe zone from the blowing gas in accordance with WIGE 2.1 Section 6.0 Safety Zone.

UNCONTROLLED IF PRINTED

EMERGENCY PLAN

April 1, 2023

EMER 2.4.4 Gas Field Personnel Dispatched to Gas in a Sewer Hazardous Condition

1.0 Dispatched to Gas in Sewer - Hazardous Condition (§192.615(a)(3)(i), (a)(7), (a)(8), (a)(9))

This section concerns gas found in sanitary and storm sewers, vaults, and underground conduits subjected to gas migration. The following steps outline the actions for AIC's gas field personnel and the Gas Supervisor (see [Subsection 1.6](#)).

1.1 Upon arrival:

- 1.1.1 Park away from and upwind of the manhole/utility access cover (manhole cover) to be investigated. For additional parking considerations, see **CAUTION** under [EMER 2.4 Subsection 4.7](#).
- 1.1.2 Secure the immediate area of the manhole cover to be investigated.
- 1.1.3 Keep excavators, emergency response personnel, and the general public at a safe distance upwind of the secure area. For additional safe distance considerations, see **NOTE** under [EMER 2.4 Paragraph 4.5.5](#).

1.2 At the manhole cover:

- 1.2.1 Remove the manhole cover.
- 1.2.2 Place a cone near the manhole opening to ensure it is visible.

1.3 Sample the environment below the rim of the manhole cover with CGI:

- 1.3.1 Assume the source is natural gas until an ethane identifier has been used to verify the source as either foreign gas or natural gas. See **LEAK 3** for ethane identifier instrument instructions.
- 1.3.2 A hazardous condition exists if CGI reads 30% LEL or greater.

1.4 Evaluate the situation by removing additional manhole covers to vent the gas and take additional readings.**1.5 Contact AIC's Dispatcher and/or Gas Supervisor, provide an update of the situation, and request:**

- 1.5.1 Additional assistance from AIC.
- 1.5.2 Calls be made to proper authorities such as Fire Department, Police Department, electric and other affected utilities, etc., if appropriate.

1.6 Gas Supervisor or designee shall:

- 1.6.1 In conjunction with the Gas Superintendent and Gas Control,
 1. Determine the consequences and necessity of an immediate shutdown.
 2. Consider whether to implement [EMER 2.4.11](#). Loss and Restoration of Service.
 3. Consider the temporary use of CNG Trailers. See [EMER 2.9](#).

UNCONTROLLED IF PRINTED

- 1.7 If the Gas Supervisor/Gas Superintendent determines there may be a potential for isolating or shutting down a section/segment of the system, contact Gas Control to verify that the affected system is remotely monitored. See [EMER 2.4 Subsection 4.8](#).
- 1.8 Check adjacent structures for hazardous conditions from gas migration by checking for gas concentrations at the entrances.
 - 1.8.1 Knock on the door (NEVER use the doorbell or intercom).
 - 1.8.2 Show AIC identification.
 - 1.8.3 If gas is detected upon first entering the structure, a reading of 10% LEL (0.5% gas-in-air) or greater is considered a hazardous condition and evacuate the structure, see [EMER 2.4 Subsection 4.5](#), and then contact AIC Dispatch, see [EMER 2.4.1 Subsection 1.8](#).
 - 1.8.4 If it is determined that there is not a hazardous condition in adjacent structures, continuously monitor the structures, checking for gas migration through sewer laterals at floor drains, sewer entry, and sump pumps.
 - 1.8.5 If gas is detected migrating into additional structures in the affected area, evacuate the structures. See [EMER 2.4 Subsection 4.5](#).
 - 1.8.6 Shut off readily accessible meter valves ensuring that no one enters the structure to shut off a meter valve. See [EMER 2.4 Subsection 4.2](#) *before touching the gas meter valve* for shut off.
 - 1.8.7 Eliminate as many ignition sources as possible without exposing oneself to danger by requesting that the electric and telephone be disconnected for the affected area.
- 1.9 As additional assistance arrives on the scene:
 - 1.9.1 Ensure that evacuated occupants have been moved to a safe distance from the structures. For additional safe distance considerations, see **NOTE** under [EMER 2.4 Paragraph 4.5.5](#).
 - 1.9.2 Remove additional manhole covers to vent the gas and determine the extent of migration.
 - 1.9.3 Continue to monitor the structures for possible gas migration.
- 1.10 After the emergency has been evaluated, see [EMER 2.4 Subsection 4.6](#) to isolate the leak.
- 1.11 Once the gas supply has been shut off, ventilate the structure after external ignition sources have been disconnected.
- 1.12 Once it is determined that a hazardous condition no longer exists:
 - 1.12.1 Ensure that all meters in the affected area have been shut off while the repairs are taking place. See [EMER 2.4 Subsection 4.2](#) *before touching the gas meter valve* for shut off.
 - 1.12.2 Complete the repairs, purge the system, and relight all affected customers.
 - 1.12.3 See [EMER 2.4.11](#), [PURG 2](#) and [TURN](#) for additional information.

End of Instructions.

Document Rescission

EMER 2.4.4 Emergency Plan: Gas Field Personnel, October 1, 2021.

UNCONTROLLED IF PRINTED

Revision Notes

Location of Changes	Summary of Changes
Paragraph 1.3.1	Removed "See Figure 1" and the picture of the Heath EI-4 Ethane Identifier. Added "See LEAK 3 for ethane identified instrument instructions."

EMERGENCY PLAN

October 1, 2022

EMER 2.4.5 Gas Field Personnel Dispatched to Gas Related Fire, Ignition, or Explosion**1.0 Dispatched to Gas Related Fire, Ignition, or Explosion
(§192.615(a)(3)(ii), (a)(3)(iii), (a)(7), (a)(8), (a)(9))**

The following steps outline the actions for AIC's gas field personnel and the Gas Supervisor (see [Subsection 1.5](#)).

- 1.1 Park upwind of the incident site. For additional parking considerations, see **CAUTION** under [EMER 2.4 Subsection 4.7](#).
- 1.2 Approach the incident site from the upwind location.

- Do not extinguish a gas-fed fire unless the flow of gas is controlled, or the fire is endangering the integrity of pressure control facilities and over-pressure protection.
- Be aware that extinguished gas ignition before the flow of gas is isolated may reignite or migrate into locations where levels can accumulate and potentially lead to an explosion.

- 1.3 If local emergency response agency:
 - 1.3.1 Has NOT arrived at the incident site, see [Subsection 1.4](#).
 - 1.3.2 Has already arrived at the incident site, see [Subsection 1.10](#).
 - 1.3.3 Arrives later and sets up an ICS at the incident site, see [Subsection 1.9](#).

Remember in a fire situation, the Fire Department has jurisdiction and is in charge of the scene.

- 1.4 If Fire Department not on site, AIC's gas field personnel shall:
 - 1.4.1 Keep the affected area evacuated.
 1. See [EMER 2.4 Subsection 4.5](#) if a structure needs to be evacuated.
 2. Direct other non-emergency response people to move to a safe location. For safe distance considerations, see **NOTE** under [EMER 2.4 Paragraph 4.5.5](#).
 3. Ensure only emergency vehicular equipment is operated within the affected area.
 - 1.4.2 Evaluate the situation:
 1. Determine if the fire, ignition, or explosion has created an immediate hazard to life or property.

UNCONTROLLED IF PRINTED

2. What gas facilities are involved such as: mains, services, meter sets, transmission or high-pressure distribution facilities, or other gas facilities.
- 1.4.3 Report the observations and information gathered in Paragraph 1.4.2 to the appropriate Gas Supervisor or Dispatcher and request:
 1. Additional assistance from AIC.
 2. Calls be made to proper authorities such as Fire Department, Police Department, Ambulance, electric and other affected utilities, etc.
- 1.4.4 See [Subsection 1.6](#) until help arrives.
- 1.4.5 See [Subsection 1.7](#) when additional AIC personnel arrive.
- 1.4.6 See [Subsection 1.8](#) when electric, telephone and cable utility company personnel arrive.
- 1.4.7 See [Subsection 1.9](#) when fire Department personnel arrive.
- 1.5 Gas Supervisor or designee shall:
 - 1.5.1 Notify the Gas Tech Services Supervisor if transmission or high-pressure distribution facilities are involved.
 - 1.5.2 Notify the Gas Superintendent with a brief explanation of the situation and the types of gas facilities that may be affected.
 - 1.5.3 Depending on the extent of the situation, if the Gas Supervisor/Gas Superintendent determines there may be a potential for isolating or shutting down a section/segment of the system, contact Gas Control to verify that the affected system is remotely monitored. If Gas Control verifies that the affected system is remotely monitored, see [EMER 2.4 Subsection 4.8](#).
 - 1.5.4 In conjunction with the Gas Superintendent and Gas Control,
 1. Determine the consequences and necessity of an immediate shutdown.
 2. Consider whether to implement [EMER 2.4.11](#). Loss and Restoration of Service.
 3. Consider the temporary use of CNG Trailers. See [EMER 2.9](#).
- 1.6 Until help arrives, AIC's gas field personnel shall:
 - 1.6.1 Continue the activities in [Paragraph 1.4.1](#) and as circumstances allow:
 1. Check gas meter set components for possible damage due to the fire. See [EMER 2.4 Subsection 4.2](#) before touching the meter. See [INVE](#).
 - 1 a. If there is any indication of damage, eliminate gas service to the damaged component to ensure that no gas can leak by or through that component.
 - 1 b. Do not remove component unless it is in danger of being damaged to the point of contributing to the fire or until instructed to do so by Gas Supervisor.
 2. Check adjacent structure(s) for possible gas migration.
 - 2 a. Check for gas concentrations at the entrances.
 - (i). Knock on the door (NEVER use the doorbell or intercom).
 - (ii). Show AIC identification.

UNCONTROLLED IF PRINTED

- 2 b. Evacuate the structure if a hazardous condition exists. See [EMER 2.4 Subsection 4.5](#).
 - 2 c. Bar hole test or leak survey around the foundation.
 - 2 d. If gas is found, complete the leak investigation procedures. See [LEAK 2.2](#).
 3. Check adjacent structures for possible damage to gas meter sets. See [EMER 2.4 Subsection 4.2](#) *before touching the meter*.
 - 3 a. If there is any indication of damage, eliminate gas service to the damaged component to ensure that no gas can leak by or through that component.
 - 3 b. Do not remove component unless it is in danger of being damaged to the point of contributing to the fire or until instructed to do so by Gas Supervisor.
 4. Eliminate as many ignition sources as possible without being exposed to danger.
- 1.7 When additional AIC personnel arrive, they shall:
- 1.7.1 Make contact with AIC's first responder.
 - 1.7.2 Continue work under [Paragraph 1.6.1](#) as directed by AIC's first responder.
- 1.8 When electric, telephone and cable utility personnel arrive, they shall:
- 1.8.1 Make contact with AIC's gas field personnel.
 - 1.8.2 Disconnect their respective services to the structure from its external sources.
 - 1.8.3 The electric source shall be disconnected at the power pole or transformer away from the structure.
- Shutting electricity off at the AMI meter does not satisfy Paragraph 1.8.3 since the switching action in the AMI meter can create a spark.
- 1.8.4 If possible, cut the telephone line at a point away from the structure.
 - 1.8.5 If not possible, cut or disconnect the telephone line at the junction box:
 1. Check the junction box on the structure for possible concentration of gas.
 2. If safe, cut or disconnect the telephone line at the junction box.
 3. If not safe, ventilate until safe, then cut or disconnect the telephone line at the junction box.
 - 1.8.6 Report to Fire Chief or fireman in charge if on site. Otherwise, report to AIC's gas field personnel.
- 1.9 AIC's gas field personnel shall make contact with the Fire Chief or fireman in charge, and:
- 1.9.1 Provide a status report on the work undertaken prior to the arrival of the Fire Department:

UNCONTROLLED IF PRINTED

1. By AIC's gas field personnel under Subsections [1.4](#) and [1.6](#).
 2. By the Gas Supervisor, Gas Superintendent, and Gas Control under [Sub-section 1.5](#).
 3. By AIC's additional personnel under [Paragraph 1.6.1](#).
 4. By electric, telephone, and cable utility personnel under [Subsection 1.8](#).
- 1.9.2 Ask permission to complete the activities reported upon in Paragraph 1.9.1.
1. If permission granted for all subparagraphs, proceed.
 2. If permission not granted for all, proceed where permission was granted and inform the Gas Supervisor of where permission was withheld.
- 1.10 If Fire Department is already on site, AIC's gas field personnel shall make contact with the Fire Chief or fireman in charge, and ask:
- 1.10.1 Has Fire Department shut off the gas to the burning structure?
1. If shut off done, ask for permission to inspect the meter valve.
 - 1 a. If permission granted, see [Paragraph 1.10.2](#).
 - 1 b. If permission not granted, inform the Gas Supervisor.
 - 1 c. See [Subsection 1.11](#).
 2. If shut off not done, ask for permission to shut off the meter set.
 - 2 a. If permission granted and the gas meter set can be safely approached,
 - (i). See [EMER 2.4 Subsection 4.2](#) before touching the gas meter.
 - (ii). Shut off and red pin the meter valve.
 - (iii). Complete the OAS 6H screen. See [EMER 2.4 Appendix A](#).
 - (iv). See [Subsection 1.11](#).
 - 2 b. Inform the Gas Supervisor if:
 - (i). Permission to shut off gas meter NOT granted, and/or
 - (ii). Cannot safely approach gas meter.
 - 2 c. See [Subsection 1.11](#).
- 1.10.2 Fire Department has shut off the gas and granted permission to inspect the meter set.
1. If the gas meter set can be safely approached, see [EMER 2.4 Subsection 4.2](#) before touching the gas meter.
 2. Verify position of the meter valve
 - 2 a. If valve is shut off, red pin the meter valve.
 - 2 b. If valve is NOT shut off, shut off valve and red pin the meter valve.
 3. Complete the OAS 6H screen. See [EMER 2.4 Appendix A](#).
- 1.11 If the following tasks are not already completed, complete them:
- 1.11.1 See [Paragraph 1.6.1.1](#): meter set at the burning building.
 - 1.11.2 See [Paragraph 1.6.1.2](#): possible gas migration at adjacent structures.

UNCONTROLLED IF PRINTED

1.11.3 See [Paragraph 1.6.1.3](#): possible meter damage at adjacent structures.

1.12 Once it is determined that a hazardous condition no longer exists and the proper authorities have taken control of the situation, review and if necessary, follow procedures [INCD](#) and [INVE](#).

End of Instructions

Document Rescission

EMER 2.4.5 Gas Field Personnel – Gas Related Fire, Ignition, or Explosion, October 1, 2020

Revision Notes

Location of Changes	Summary of Changes
Paragraph 1.10.1	Revised – Has Fire Department shut off gas to the burning structure?
Paragraph 1.10.1 – Item 1.	Revised – If shut off is done, ask permission to inspect the meter set.
Paragraph 1.10.2	Revised – Fire Department has shut off the gas and granted permission to inspect the meter set: 2. Verify position of the meter valve.

EMERGENCY PLAN

April 1, 2023

EMER 2.4.6 Gas Field Personnel Dispatched to Non-Gas Related Fire, Ignition, or Explosion

**1.0 Dispatched to Non-Gas Related Fire, Ignition, or Explosion
(§192.615(a)(3)(ii), (a)(3)(iii), (a)(7), (a)(8), (a)(9))**

The following steps outline the actions for AIC's gas field personnel.

- 1.1 Park upwind of the incident site. For additional parking considerations, see **CAUTION** under [EMER 2.4 Subsection 4.7](#).
- 1.2 Approach the incident site from the upwind location.
- 1.3 Evaluate the situation; determine if the fire, ignition, or explosion has created an immediate hazard to life or property and if a gas facility is involved, such as main, service, meter set, or other gas facility.

Remember in a fire situation, the Fire Department has jurisdiction and is in charge of the scene.

- 1.4 Make contact with the Fire Chief or fireman in charge to see if there has been a determination whether or not gas was the cause of the fire or explosion.

If a determination has not been made, advise your Gas Supervisor or Duty Supervisor and request guidance if follow-up action is necessary.

- 1.5 If the Fire Chief or fireman in charge has determined that gas was not the cause for the fire or explosion:
 - 1.5.1 Check if the fire department wants the gas shut-off or has already shut-off the gas.
 - 1.5.2 If the gas does not need to be shut off:
 1. The gas field person should evaluate whether the fire has damaged any of the gas appliances or piping.
 2. If there is no evidence of any damage or adverse effects on the gas facilities or appliances, the gas service can be left on.

If a damaged appliance can be isolated, the main service can be left on

3. Enter comment on OAS 63 screen that gas service did not need to be shut off.

UNCONTROLLED IF PRINTED

1.5.3 If the Fire Department has shut-off the gas or wants the gas shut-off to the structure:

1. Ask permission to inspect meter set.
2. Check to see what valves are present and which one is or can be shut-off.
 - 2a. If a customer convenience valve (CCV) is present, it can be used to shut-off the gas to the structure. **The meter valve can either be turned back on or left on.**
 - 2b. If the meter valve has to be left in the closed position, red pin the valve. Complete the OAS 6H screen. See [EMER 2.4 Appendix A](#).
 - 2c. Check components for possible damage due to the fire.
 - 2d. If there is any indication of damage, eliminate gas service to the damaged component to ensure that no gas can leak by or through that component.
 - 2e. See [INVE 2.2](#). Investigation of Fires

1.6 If the information received indicates that natural gas was not involved in the cause of the fire:

- 1.6.1 No further investigation is required.
- 1.6.2 Within one business day, AIC's gas field personnel shall notify the Gas Supervisor that they responded to a fire.

1.7 Service cannot be restored to the customer until:

- 1.7.1 Fire Department has completed their investigation, has released the scene, or has okayed restoration of service. AND
- 1.7.2 Gas field personnel have inspected the facilities for damage. AND
- 1.7.3 No damage was found, OR
- 1.7.4 Damaged facilities isolated, replaced, or repaired.

End of Instructions

Document Rescission

EMER 2.4.6 Emergency Plan – Dispatched to Non-Gas Related Fire, Ignition, or Explosion, October 1, 2022

Revision Notes

Location of Changes	Summary of Changes
Subsection 1.4 NOTE	Revised – If a determination has not been made, advise your Gas Supervisor or Duty Supervisor and request guidance if follow-up action is necessary.
Paragraph 1.5.3, Item 2 a.	Merged original 2 a. (i) The meter can be either turned back on or left off. in with 2 a.

UNCONTROLLED IF PRINTED

Paragraph 1.5.2, Item 2 b.

Removed – Check to make sure gas is not passing through the closed CCV.

UNCONTROLLED IF PRINTED

EMERGENCY PLAN

October 1, 2020

EMER 2.4.7 Gas Field Personnel Dispatched to Explosion and/or Fire Near Gas Pipeline Facilities**1.0 Dispatched to Explosion and/or Fire Near Gas Pipeline Facilities (§192.615(a)(3)(ii), (a)(3)(iii), (a)(7), (a)(8), (a)(9))**

The following steps outline the actions for AIC's field gas personnel and the Gas Supervisor (see Subsection 1.6) when responding to an explosion and/or fire near a gas pipeline facility.

- 1.1 Park upwind of the incident site. For additional parking considerations, see **CAUTION** under [EMER 2.4 Subsection 4.7](#).
- 1.2 Approach the incident site from the upwind location.
- 1.3 Determine if there is concern for the safety of people or property. An initial evaluation of the situation shall include:
 - 1.3.1 Are there gas customers being affected by the fire or explosion?
 - 1.3.2 How close is AIC's pipeline to the explosion and/or fire?
 - 1.3.3 Is the explosion and/or fire contained or is there possibility of it spreading?
 - 1.3.4 What type of AIC facilities could be affected?
 - 1.3.5 Are there above ground gas facilities present in the immediate area?
 - 1.3.6 Is the associated gas system or facilities remotely monitored by Gas Control?
 - 1.3.7 Is there a valve, either emergency or non-emergency, accessible that would isolate the gas facilities?
- 1.4 Notify Gas Supervisor if there is concern that the public, AIC's customers, and gas facilities may be impacted. Report the observations and information gathered in [Subsection 1.3](#).
- 1.5 Contact the Fire Chief or fireman in charge, communicate AIC's concerns and pertinent information about AIC's facilities. Then see [Subsection 1.8](#).
- 1.6 Gas Supervisor shall notify the Gas Superintendent with a brief explanation of the situation and the types of gas facilities that may be affected.
- 1.7 Gas Supervisor or Gas Superintendent shall contact Gas Control to see if the associated gas system or facilities are being remotely monitored and if there is any indication of impact on those facilities.
- 1.8 Gas Supervisor or Gas Superintendent shall make the determination if gas facilities need to be inspected, isolated, or disconnected from the system.
 - 1.8.1 If an explosion occurred within 25 feet of AIC gas facilities, a leak survey shall be conducted over and around all gas facilities located within a minimum of 100 feet in all directions of the explosion.
 - 1.8.2 AIC's field gas personnel shall begin the walking leak survey. See [LEAK 2.6](#).
 1. Follow instructions from Gas Supervisor and see [Paragraph 1.11.2](#).
- 1.9 Gas Tech Services Supervisor or Gas Storage Supervisor and Gas Control shall be notified if any of the following are affected:

UNCONTROLLED IF PRINTED

- 1.9.1 High pressure distribution or transmission pipelines.
 - 1.9.2 Pressure control or flow control station(s).
 - 1.9.3 Above ground valve station(s).
 - 1.9.4 Storage field/compressor station facilities.
 - 1.9.5 Odorization facilities.
- 1.10 Gas Tech Services or Gas Storage Supervisor will determine what procedures should be taken for the protection of the above listed facilities.

Facilities can be isolated or temporarily disconnected by the use of valves, control fittings, or squeezing.

- 1.11 The Gas Supervisor shall assign additional gas field personnel to the site when the scope of the response has been determined.
- 1.11.1 The additional personnel shall report to AIC's first responder upon arrival.
 - 1.11.2 AIC's field gas personnel shall provide the Fire Department person in charge with an update of AIC's activities.
- 1.12 Depending on the extent of the situation:
- 1.12.1 If the Gas Supervisor/Gas Superintendent and/or Gas Tech Service Supervisor determines:
 1. There may be a potential for isolating or shutting down a section/segment of the system:
 - 1 a. Contact Gas Control to verify that the affected system is remotely monitored.
 - 1 b. If Gas Control verifies that the affected system is remotely monitored, see [EMER 2.4 Subsection 4.8](#).
- 1.13 Gas Supervisor shall:
- 1.13.1 In conjunction with the Gas Superintendent and Gas Control,
 1. Determine the consequences and necessity of an immediate shutdown.
 2. Consider whether to implement [EMER 2.4.11](#). Loss and Restoration of Services.
 3. Consider the temporary use of CNG Trailers. See [EMER 2.9](#).
- 1.14 Once the emergency situation has been eliminated, the integrity of any disconnected gas facilities shall be determined prior to reinstating the facilities into operations. See [PURG](#) and [RNST](#).

End of Instructions

Document Rescission

EMER 2.04 Emergency Plan: Gas Field Personnel, April 1, 2020.

Revision Notes

UNCONTROLLED IF PRINTED

Location of Changes	Summary of Changes
Not applicable.	This is a new document.

UNCONTROLLED IF PRINTED

EMERGENCY PLAN

October 1, 2020

EMER 2.4.8 Gas Field Personnel Train Derailment near Pipeline Facilities

1.0 Train Derailment near Pipeline Facilities (§192.615 (a)(5), (a)(6), (a)(7), (a)(8), (a)(9))

- 1.1 When notified of a train derailment, the Gas Supervisor shall:
 - 1.1.1 Verify if AIC pipeline facilities are located within the vicinity of the derailment.
 - 1.1.2 When AIC pipeline facilities are located within the vicinity of the derailment:
 - 1. Provide pertinent information to rail operators and emergency response officials:
 - 1 a. So that movement of heavy equipment and debris on the right-of-way does not:
 - (i.) Pose a hazard to the public, AIC's customers, and people working in and around the derailment.
 - (ii.) Damage or rupture the pipeline
 - 1 b. The information shall include verification of: Presence.
 - (i). Depth
 - (ii). Location
 - 1.1.3 Notify AIC's Gas Integrity Management group of the derailment.
 - 1.1.4 Once the emergency situation has been eliminated, the integrity of any gas facilities involved shall be determined prior to reinstating the facilities into operations. See [PURG](#) and [RNST](#).

End of Instructions

Document Rescission

EMER 2.04 Emergency Plan: Gas Field Personnel, April 1, 2020.

Revision Notes

Location of Changes	Summary of Changes
Not applicable.	This is a new document.

UNCONTROLLED IF PRINTED

EMERGENCY PLAN

April 1, 2021

EMER 2.4.9 Gas Field Personnel Low-Pressure Situation**1.0 Low-Pressure Situation (§192.615 (a)(5), (a)(6), (a)(7), (a)(8), (a)(9))**

- When responding to a low-pressure situation, a major concern is that pilot lights may go out resulting in gas leaking into the customers' structures.
- Pressures below 4" W.C. on low-pressure systems and 2 PSIG on distribution pressure systems may cause pilot outage.

Low pressure may result from any of the following:

- Line break.
- Line obstruction.
- Mechanical failure in a regulator station.
- Ice formation over vents of regulators.
- Increased load on the system.
- Unintentional shutting off or restricting gas supply to an area.

1.1 When a low-pressure situation is discovered, gas field personnel shall:

1.1.1 Immediately notify the Gas Supervisor of the low-pressure situation and:

1. Identify the extent and general geographical location of the low-pressure area.
2. Request additional assistance if necessary.

1.1.2 Check the pressures at the extremities of the system.

1.1.3 Determine if the low pressure will create a customer outage.

1.1.4 Check for pilot outages and close and lock the meter valve of those customers affected if the pressure drops below a safe level.

1. See [EMER 2.4 Paragraph 4.2](#) before touching the meter.

1.1.5 Isolate the affected area to conserve pressure in adjacent areas.

1. Use maps showing critical valves and pressure control stations.

1.1.6 In conjunction with the Gas Supervisor and Gas Superintendent,

1. Discuss the possibility of bypass operations to stabilize the distribution pressure.

UNCONTROLLED IF PRINTED

2. Identify critical customers such as hospitals, nursing homes, schools or other public facilities that may need additional support or temporary supply during an outage.
 3. Discuss possible curtailments of large use customers.
 4. Implement the results of these discussions.
- 1.2 Gas Supervisor shall notify Gas Control of the situation and advise them of any assistance that may be needed or could be provided with the affected system(s). If Gas Control verifies the affected system is remotely monitored, see [EMER 2.4 Subsection 4.8](#).
- 1.3 Gas Supervisor, in conjunction with Gas Superintendent and Gas Control, shall:
- 1.3.1 Determine the consequences and necessity of an immediate shutdown.
 - 1.3.2 Consider whether to implement [EMER 2.4.11](#), Loss and Restoration of Services.
 - 1.3.3 Consider the temporary use of CNG Trailers. See [EMER 2.9](#).
- 1.4 After the repairs are complete to correct the cause of the low pressure, purge the system of air and relight the affected customers. See [PURG](#) and [TURN](#).

End of Instructions

Document Rescission

EMER 2.04 Emergency Plan: Gas Field Personnel, April 1, 2020.

Revision Notes

Location of Changes	Summary of Changes
Not applicable.	This is a new document.

EMERGENCY PLAN

October 1, 2020

EMER 2.4.10 Emergency Plan: Gas Field Personnel Over-Pressure Situation

1.0 Over-Pressure Situation (§192.615 (a)(5), (a)(6), (a)(7), (a)(8), (a)(9))

- When responding to a high-pressure situation, a major concern is the effect of the pressure exceeding the Maximum Emergency Pressure (MEP) of the system. See [Table 1](#).
- This effect may result in serious leaks, fires, explosions, and the customers' appliances burning out of control.

- All systems have an allowable build up over the established Maximum Allowable Operating Pressure (MAOP).
- This allowable build up is the MEP. See [Table 1](#).
- A relief valve or over pressure protection device should be operating if the system pressure has exceeded the MAOP. Relief valves are designed to vent system gas to the atmosphere.
- The system pressure may exceed the Normal Operating Pressure up to the MAOP established for each system.

- Increasing system pressure may result from any of the following:
- Mechanical failure in a regulator station.
 - Decreased load on the system.
 - Unintentional gas supply entering the system.

Table 1: Normal Operating and Maximum Emergency Pressures for Pressure Classes

Pressure Class	Normal Operating Pressure	Maximum Emergency Pressure (MEP)
Low-Pressure	4" W.C. to 14" W.C.	27.6" W.C.
Distribution Pressure 1	1 PSIG < 12 PSIG	MAOP + 50%
Distribution Pressure 2	12 PSIG < 60 PSIG	MAOP + 6 PSIG
High-Pressure Distribution & Transmission	60 PSIG & Over	MAOP + 10% or 75% SMYS whichever is less

UNCONTROLLED IF PRINTED

- 1.1 If system pressure exceeds the MAOP of the system, gas field personnel shall:
 - 1.1.1 Immediately notify the Gas Supervisor who shall refer to Subsections [1.3](#), [1.4](#), and [1.5](#).
 - 1.1.2 Allow a relief valve to continue blowing. DO NOT valve off the relief valve.
 - 1.1.3 Continue troubleshooting the system for probable causes.
 - 1.1.4 When the operator qualified regulator personnel or technician arrives, see [Sub-section 1.6](#).
- 1.2 If the system pressure has exceeded the MEP, the gas field personnel shall immediately notify the Gas Supervisor.
 - 1.2.1 The Gas Supervisor shall:
 - 1. Immediately contact Gas Superintendent, Supervisor GTS and Director Pipeline Safety and Compliance. See [PRES 2.1](#) for additional information.
 - 2. Consider to at least communicate with the local fire department and/or police in case their assistance may be needed.
- 1.3 Gas Supervisor shall notify Gas Control of the situation and advise them on any assistance that may be needed or could be provided with the affected system. If Gas Control verifies that the affected system is remotely monitored, see [EMER 2.4 Subsection 4.8](#).
- 1.4 Gas Supervisor, in conjunction with Gas Superintendent and Gas Control, shall:
 - 1.4.1 Determine the consequences and necessity of an immediate shutdown.
 - 1.4.2 Consider whether to implement [EMER 2.4.11](#), Loss and Restoration of Services.
 - 1.4.3 Consider the temporary use of CNG Trailers. See [EMER 2.9](#).
- 1.5 Gas Supervisor or Gas Tech Services Supervisor shall ensure an operator qualified regulator personnel or technician has been notified and dispatched.
- 1.6 The operator qualified regulator personnel or technician shall work with the on-site gas field personnel as follows.
 - 1.6.1 Use valves to throttle or shut down the feed to the system until the pressure is within the normal operating range.
 - 1. Valves shall be continuously monitored until pressure is within the normal operating range.
 - 1.6.2 Troubleshoot to identify the reason for the high-pressure situation.
 - 1.6.3 Make repairs and reestablish normal operating pressure to the affected area.

End of Instructions

Document Rescission

EMER 2.04 Emergency Plan: Gas Field Personnel, April 1, 2020.

Revision Notes

Location of Changes	Summary of Changes
Not applicable.	This is a new document.

UNCONTROLLED IF PRINTED

UNCONTROLLED IF PRINTED

EMERGENCY PLAN

October 1, 2020

EMER 2.4.11 Gas Field Personnel Loss and Restoration of Service

1.0 Loss and Restoration of Service (§192.615(a)(5), (a)(6), (a)(7), (a)(8), (a)(9))

When a general loss of system pressure is detected,

- Actions shall be directed toward protecting people first and then property.
- The cause and effect of the pressure loss shall be determined.
- A qualified work force shall be established to safely restore service to the affected area.

The following steps shall be taken whenever there is a major loss of service that is expected to take more than 8 hours to restore.

1.1 Gas Control, Dispatch and/or gas field personnel shall notify Gas Supervisor of the loss of system pressure.

1.2 Gas Supervisor/Gas Superintendent shall contact Gas Control to:

1.2.1 Determine or verify that the affected system or adjacent systems are remotely monitored.

1.2.2 Notify them of the situation and discuss assistance Gas Control may be able to provide with monitoring operating parameters of the affected and adjacent systems. See [EMER 2.4 Subsection 4.8](#) regarding communications.

1.2.3 Consider the temporary use of CNG Trailers. See [EMER 2.9](#).

1.3 Gas field personnel shall:

1.3.1 Determine the cause for the loss of service and isolate the affected area from the rest of the system.

1.3.2 Identify critical customers such as hospitals, nursing homes, schools or other public facilities that may need additional support or temporary supply during an outage.

1.3.3 Identify the extent of the loss of service and the number of customers affected.

1.3.4 Conduct pressure checks on the outer ends of the system.

1.3.5 Check for pilot light outage.

1.3.6 Plot the outage area on a system map.

1.3.7 Estimate the number of customers out of service.

1.4 Gas Supervisor may obtain a list of gas customers for the affected outage. The customer list is obtained by contacting Gas Engineering, DDC/PDC, or Gas Tech Engineering - Planning group who can assist in obtaining a list.

1.5 An AIC designated person shall notify other appropriate groups about of the loss of service.

1.5.1 Customer Care Center (Provide a general description of the loss of service area.)

UNCONTROLLED IF PRINTED

- 1.5.2 Dispatch.
- 1.5.3 Gas Tech Services Supervisor shall be contacted if transmission or high-pressure distribution facilities or regulator stations are involved.
- 1.5.4 Gas Compliance.
- 1.5.5 Affected large industrial and commercial customers and management of public housing units.
- 1.5.6 Fire and Police Departments.
- 1.5.7 Other Regions if assistance may be required.

If the Emergency Operations Center (EOC) is activated for a major outage, they shall assume control and coordinate obtaining the necessary resources from outside the affected Region.

- 1.6 AIC Communication shall notify local media.
 - 1.6.1 If the loss of service has affected a large area, the Region Director, in consultation with AIC Communication, may initiate a news release to local newspapers, radios, and TV stations.
 - 1.6.2 Inform the public of the area affected.
 - 1.6.3 Notify the public that gas field personnel will be assigned to turn-on their appliances. Suggest that the affected customers leave their porch light on if they wish to be turned-on during the evening hours.
 - 1.6.4 Customers should not attempt to turn-on their own appliances during the outage.
 - 1.6.5 Give a brief description of the cause for loss of service.
- 1.7 Gas Compliance shall notify Illinois Commerce Commission and Illinois Emergency Management Agency in the event that the loss of service affects a large area and it is apparent that more than 1000 people, approximately 400 meters, will be without gas for a period of 24 hours or more. See [INCD 1](#) for the protocol to report this event.
- 1.8 Gas Supervisor/Gas Superintendent shall consider the following when determining the appropriate staffing levels to respond to the emergency:
 - 1.8.1 Plan for a maximum time of 24 hours for complete restoration of service.
 - 1. Cold weather conditions may require restoration time frame to shorten.
 - 1.8.2 Each qualified gas field personnel should be able to turn-on 5 customers per hour.
 - 1.8.3 Assign one Gas Supervisor to supervise the work of approximately 10 gas field personnel.
 - 1.8.4 Plan for a two-person forcible entry crew for inaccessible meters.
 - 1.8.5 Request EOC assistance for additional contractors, and/or other resources from outside the Region.
- 1.9 Gas Supervisor/Gas Superintendent or designated person shall organize the OAS workflow.

- 1.9.1 Notify Dispatch that the Region will handle the OAS orders relating to the loss of service for the affected area. Dispatch shall continue to handle emergency leak calls.
- 1.9.2 Request assistance from local office personnel to process the OAS orders.
- 1.10 Gas Supervisor/Gas Superintendent shall organize the work force.
 - 1.10.1 One Gas Supervisor shall have the overall responsibility for coordinating the restoration of service.
 - 1.10.2 Gas Supervisor or designee will maintain the customer record at the assigned headquarters.
 - 1.10.3 Gas Supervisor or designee shall use the customer record to cross reference all customer turned off and turned on from the Emergency Gas Meter Status Record form. See [EMER 3](#) for copy of Emergency Gas Meter Status Record form.
 - 1.10.4 Divide the outage into manageable areas.
 - 1.10.5 Assign 5 to 10 gas field personnel and a Gas Supervisor to each area.
 1. Each supervisor will be given maps for the affected area.
 2. Gas field personnel shall be assigned designated streets/area to turn off, and
 3. Record the information on the Emergency Gas Meter Status Record form.
 - 1.10.6 If possible, the same gas field personnel should be assigned to turn-on the same area that they were assigned to turn-off.
 - 1.10.7 Review turn-off/turn-on requirements for an outage.
- 1.11 Gas field personnel Turn-off requirement for an outage:
 - 1.11.1 Turn-off the meter valve or curb valve for each affected customer: The meter valve shall be locked. See [EMER 2.4 Subsection 4.2](#) *before touching gas meter*.

Locking the meter valve ensures customer does not attempt to re-light during the outage.

 - 1.11.2 Record the address and meter number on the Emergency Gas Meter Status Record form.
 - 1.11.3 Place an outage door hanger on the customer's door to notify them of the loss of service and that a turn-on will occur after the gas has been restored.
 - 1.11.4 Consider painting a white dot or other indicating method on or at the curb in front of the premise to indicate that the meter valve is off.
 - 1.11.5 If the meter valve or curb valve is inaccessible, record the address and meter number. Turn this information over to the Gas Supervisor for the forcible entry crew.
 - 1.11.6 The recorded meter numbers and addresses shall be correlated with the meter list to ensure that all affected customers are turned off.
- 1.12 Gas Supervisor is responsible for verifying that all meters are turned-off in their assigned area.

UNCONTROLLED IF PRINTED

- 1.13 For cases where the turn-off cannot be made without forcible entry:
 - 1.13.1 A two-person forcible entry crew shall be assigned the work.
 - 1.13.2 A locksmith shall be utilized to access the premise.
 - 1.13.3 Ameren Security personnel, police officer, or neighbor shall witness a forced entry and asked to stand by while work is performed inside the premise.
 - 1.13.4 A cone shall be placed at each entrance to the premise if no one is available to stand by while work is performed.
 - 1.13.5 The premise must be secured following the forced entry.
 1. Leave a door hanger or notice notifying the customer that due to an emergency, AIC had to make a forcible entry.
 2. Door hanger or notice shall contain AIC's contact number 800-755-5000.
 - 1.13.6 Document damage to the premise from the forced entry along with the names of those present.

<p>If police officer witnessed the forced entry, record the officer's name and badge number.</p>
--

- 1.13.7 Notify Corporate Claims that damage has occurred. See [INCD 1 Appendix D](#).
- 1.14 During the meter turn-off phase, available supervisory personnel shall have a conference to formulate detailed plans for:
 - 1.14.1 Purging and the re-pressurization of the system. See [PURG 2](#).
 - 1.14.2 Customer turn-on process and a list of essential/priority customers.
 - 1.14.3 Ensuring an adequate supply of flashlights, batteries, wrenches, appliance lighters, matches, etc.
 - 1.14.4 Reviewing the instructions to be given to gas field personnel prior to beginning the turn-on process.
- 1.15 Before the reintroduction of gas in the system, Gas Supervisor shall complete a final verification that all affected customers have been shut off to prevent the escape of natural gas into the structures and/or an air/gas mixture in the piping systems.
- 1.16 The purge and re-pressurization **shall not** begin until all affected customer meter valves are turned off.
 - 1.16.1 If possible, sectionalize the area and purge each section at the extreme ends, reintroducing gas in a moderately rapid and continuous flow. Multiple feeds shall be turned on individually rather than collectively.
 - 1.16.2 Confirm that the purge is complete with a CGI reading.
 - 1.16.3 Re-pressurize the system to the normal operating pressure.
 - 1.16.4 Individual service lines will each need to be purged of air during the turn-on process.
- 1.17 Gas field personnel shall purge and re-pressurize the system. See [PURG 2](#).

UNCONTROLLED IF PRINTED

- 1.18 An AIC designated person or Gas Supervisor shall update the Customer Care Center and AIC Communications (see [INCD 1 Appendix D](#)).
 - 1.18.1 Notify the Customer Care Center and AIC Communications when the turn-on process will begin and that gas field personnel will be contacting customers to turn on their gas and light the appliances.
 - 1.18.2 Suggest that the affected customers leave their porch light on if they wish to be turned-on during the evening hours.
 - 1.18.3 Turn-ons will continue throughout the night when temperatures are below freezing.
 - 1.18.4 If the temperatures are mild, the turn-on process may be suspended between 10:00 PM and 6:00 AM unless a porch light is on.
- 1.19 Gas Supervisor shall implement the plan to restore service to individual customers.
 - 1.19.1 Equip gas field personnel with maps, "Warning" tags, door hanger and the tools and supplies required for the turn-on process.
 - 1.19.2 The same gas field personnel should be assigned to turn-on the same area that they were assigned to turn-off.
 - 1.19.3 Prioritize to work with essential/priority customers first.
 - 1.19.4 Use the turn-off records to record the time and date that gas was restored to the customer.
 - 1.19.5 As gas is restored, forward the paperwork to the Gas Supervisor to ensure that the OAS order is closed.
 - 1.19.6 Monitor OAS for customers that have been missed during the turn-on phase.
- 1.20 Gas field personnel Turn-on requirements for an outage:
 - 1.20.1 Air must be purged from the service with natural gas before lighting the appliances.
 - 1.20.2 A 30-second shut-in test shall be performed using normal delivery pressure to ensure that there are no open fuel lines or appliance safeties that have failed in the open position.
 - 1.20.3 Customer may choose to relight their own appliance unless the 30 second shut-in test fails.
 - 1.20.4 When a customer chooses to have AIC relight the appliances, enter the premise and purge the customer's piping of air.
 - 1.20.5 Light the pilots on the gas utilization equipment. Place the equipment into operation.

During the warmer times of the year, customers may not want their pilots lit on space heating equipment.

 - 1.20.6 If a hazardous condition is observed, it shall be isolated, and a "Warning" tag installed. Report these conditions to the Gas Supervisor for follow-up action. Refer to [TURN 2.7](#) Warning Tag.

- 1.20.7 Appliances where the pilots will not remain lit shall be isolated, a "Warning" tag installed and reported to the Gas Supervisor for follow-up action.
1. AIC personnel shall contact an HVAC contractor to correct this type of appliance problem at AIC's expense.
 2. Corporate Claims (see [INCD 1 Appendix D](#)) may be utilized to process HVAC invoices.
- 1.20.8 Gas field personnel should record, at a minimum, the customer address, meter number, times, and dates of service restoration.
1. This information shall be added to the Emergency Gas Meter Status Record form, and
 2. Given to the Gas Supervisor or designee for cross reference with the customer records to assure that all customers have been turned back on.
- 1.20.9 Gas field personnel should consider painting a second white dot or other indicating method on or at the curb in front of the premise to indicate that a turn-on has been performed and the customer's appliances have been lit.
1. Multiple meter sets should have the second dot painted after all meters are turned on.
- 1.21 An AIC designated person or Gas Supervisor shall update the Customer Care Center and AIC Communications. See [INCD 1 Appendix D](#).
- 1.21.1 Notify Dispatch, Customer Care Center, and AIC Communications when the restoration of service is complete.
- 1.21.2 Request that customers contact by calling the Customer Care Center at 1-800-755-5000 if they do not have their gas turned on.
- 1.21.3 Thank the customers.

End of Instructions

Document Rescission

EMER 2.04 Emergency Plan: Gas Field Personnel, April 1, 2020.

Revision Notes

Location of Changes	Summary of Changes
Not applicable.	This is a new document.

UNCONTROLLED IF PRINTED

EMERGENCY PLAN

October 1, 2022

EMER 2.5 Natural Disasters and Civil Disobedience**1.0 Purpose**

This document outlines procedures for Ameren Illinois's (AIC's) response to natural disasters in accordance with 49 CFR §192.615 and civil disobedience.

2.0 Scope

This document addresses the following:

[3.0 Target Audience](#)**[4.0 Natural Disasters - Other Than Floods](#)****[5.0 Natural Disasters: Floods](#)****[6.0 Civil Disobedience](#)****3.0 Target Audience**

- Gas Control Personnel
- Gas Engineering
- Gas Tech Engineering (GTE)
- Gas Field Personnel
- Gas Supervisors
- Gas Tech Service (GTS) Supervisors
- Gas Tech Services (GTS) Personnel
- Gas Pipeline Integrity Management Personnel
- Gas Storage Field Supervisors
- Gas Storage Field Operators
- Gas Control

4.0 Natural Disasters - Other Than Floods (§192.615(a)(3)(iv), (a)(5))

Natural disasters other than floods may include earthquakes, landslides, tornadoes, and wild-fires. In addition to directing actions toward protecting people first and then property, the Incident Command Structure (ICS) Supervisor, Gas Supervisor or designee shall:

- 4.1 Contact Gas Control to advise them of the situation and to determine if the affected gas systems are remotely monitored.
- 4.2 If Gas Control verifies that they remotely monitor the affected systems, establish a line of communications for the purpose of:
 - 4.2.1 Keeping them updated on the status of situation throughout the disaster.
 - 4.2.2 Requesting their assistance in monitoring.
 - 4.2.3 Determining at what point Gas Control should issue a warning of potential system problem.
 - 4.2.4 Keeping Gas Control updated on the status of restoration efforts and the condition of adjacent gas systems.
 - 4.2.5 Notifying Gas Control when the situation has been corrected and the system should be back to normal operation. Verifying that monitored operating parameters have been restored.
- 4.3 Contact Gas Tech Services (GTS) or Gas Storage Field personnel if any of their respective facilities could be potentially affected such as:

UNCONTROLLED IF PRINTED

- 4.3.1 Transmission lines.
- 4.3.2 High-pressure distribution mains.
- 4.3.3 Pressure control stations.
- 4.3.4 Odorization stations.
- 4.3.5 Gas storage field lines, wells, or compressors.
- 4.3.6 GTS or Gas Storage Field personnel shall assume responsibility for their respective facilities.
- 4.4 Dispatch gas field personnel to the area of the natural disaster to:
 - 4.4.1 Determine if AIC's facilities are damaged or in danger of failing.
 - 4.4.2 Communicate with the appropriate fire department about the potential impact on AIC's facilities.
 - 4.4.3 Determine where uncontrolled overpressure exists or large amounts of gas are being released and evaluate the hazards involved.
 - 4.4.4 Prepare to isolate affected areas.
 - 4.4.5 Check adjoining systems for damage or confirm they are operating normally after affected areas are isolated.
- 4.5 Consider shutting off the gas supply to the affected area if the safety of the public or conservation of pressure in the overall system is in jeopardy.
 - 4.5.1 Advise Gas Control of areas to be isolated to determine if they can be of assistance with isolating the areas.
- 4.6 Implement other appropriate sections of the Emergency Plan.
- 4.7 Notify Director, Pipeline Safety & Compliance about the situation and provide current status reports about the situation.
- 4.8 Contact Corporate Security to arrange for security guards to protect vulnerable portions of AIC's gas facilities from further damage.
- 4.9 Consider governmental reporting requirements. See [SAFT 1](#) and [INCD 1](#).
- 4.10 Contact Corporate Communications to issue a media release to the affected area. This media release should:
 - 4.10.1 Instruct occupants to call AIC if they smell gas.
 - 4.10.2 Inform the occupant of the activities AIC is performing to ensure the safe delivery of natural gas.
- 4.11 Make an evaluation of required repairs.
- 4.12 Following the natural disaster, ensure that facilities have not been damaged or that repairs are made before gas service is restored.

5.0 Natural Disasters: Floods (§192.615(a)(3)(iv), (a)(5))

In addition to directing actions toward protecting people first and then property, the Gas Supervisor or designee shall consider:

- 5.1 Prior to Flooding:
 - 5.1.1 Determining if Gas Control needs to be contacted in cases where the affected systems are remotely monitored.

UNCONTROLLED IF PRINTED

1. Discussing options available in the event flooding does occur and establish a line of communications. See [Subsection 4.2](#).
- 5.1.2 Contacting GTS personnel and requesting their assistance if flooding could potentially affect transmission or high-pressure distribution facilities.
- 5.1.3 Leaving the system pressurized to prevent water infiltration into the mains, if possible.
 1. Service can be left on as long as the regulator and relief vents are extended above the expected high water line.
 2. Gas meters will function when submerged, but the AMI device will require replacement following submergence.
- 5.1.4 Shutting off and locking individual services where regulator and relief vents could be submerged, with priority given to inside services.
- 5.1.5 Securing odorant bulk tanks.
- 5.1.6 Contacting Gas Control prior to disconnecting telemetering equipment.
- 5.1.7 Sandbagging and protecting facilities, if possible.
- 5.1.8 Raising pressure gauges and recording equipment above anticipated flood level, if possible.
- 5.1.9 Extending regulator vent lines and relief stacks at least above the level of anticipated flooding.
- 5.2 During the Flood
 - 5.2.1 Being alert to areas of flooding and having gas field personnel available for emergency response actions such as shutdown, isolation, and containment.
 - 5.2.2 If the affected systems are remotely monitored by Gas Control,
 1. Notifying them of the situation.
 2. Discussing plans for isolating or shutting down sections of the system.
 3. Developing a plan and line of communications for keeping all involved updated of the situation.
 - 5.2.3 Evaluating the accessibility of pipeline facilities, such as emergency valves, needed to isolate water crossings or other sections of pipelines that might be jeopardized.
 - 5.2.4 Performing frequent patrols to evaluate right-of-way conditions at water crossings during flooding and after waters subside.
 1. Determining if flooding has exposed and/or undermined pipelines.
 - 5.2.5 Coordinating with other pipeline companies and communicating with personnel at emergency response centers.
 1. Providing information on pipeline location and condition to emergency responders.
 - 5.2.6 Considering extending regulator vent lines and relief stacks.
 - 5.2.7 Determining whether facilities (such as meter sets, regulator stations, valve stations, farm taps, and regulator or relief valve vent lines) that have become submerged could be struck by watercraft or floating debris.

1. Marking submerged facilities with buoys.

5.2.8 Consider governmental reporting requirements. See [SAFT 1](#) and [INCD 1](#).

5.3 Following the flood, the Gas Supervisor or GTS Supervisor, where applicable, shall ensure the following actions are taken:

5.3.1 If Gas Control was involved in any of the operations taken to protect the gas systems or gas facilities from flooding, notifying them that:

1. Flooding has receded.
2. The gas system is being returned or is at normal operations.

5.3.2 Replace AMI device on all gas meters that were submerged during the flood.

1. AMI can be replaced on the existing meter, OR
2. Exchange the meter and ship to the Gas Meter Shop. The meter should be tagged "Submerged".

5.3.3 Inspect regulator stations for water damage.

1. If water has entered equipment through breather vents or relief outlets, replacing or rebuilding the equipment.
 - 1 a. Prior to beginning work on a regulator station that is remotely monitored, advising Gas Control of the situation.
 - 1 b. Replacing aluminum regulator parts subjected to water due to the potentially corrosive nature of the flood water.
 - 1 c. Cleaning cast iron or steel regulator parts.
2. Contact Gas Control once work has been completed and verifying operating parameters have been restored.

5.3.4 Issue a Warning Tag if:

1. Water had covered the control valves on interior appliances, OR
2. If service has to be shut off. Refer to [TURN 2.7](#) Warning Tag

5.3.5 Notify customers about:

1. The potential damage associated with appliances controls and pilots being submerged in water.
2. Having a qualified plumbing or heating contractor inspect their equipment prior placing it back in service.

5.3.6 Ensure that pipeline markers are still in place.

5.3.7 Remind contractors, highway departments, and others involved in excavation and clearing activities associated with cleanup about:

1. The presence of pipelines.
2. The operating hazards that could occur due to reduced pipeline cover.

5.3.8 Where there is significant land erosion, performing surveys to determine the depth of cover over pipelines.

1. Notify landowners of reduced cover.
2. Request agricultural agencies to assist in reminding farmers of the potential hazards caused by reduced cover over pipelines.

UNCONTROLLED IF PRINTED

- 5.3.9 Create critical area patrols in Maximo for any pipeline segments that become exposed, undermined, or at risk due to reduced cover. See [PTRL 2.2](#).
- 5.3.10 Inspect any exposed gas pipeline for damage that may affect the system integrity and take measures to repair the damage. See [REPR 1](#).
- 5.3.11 If appropriate, notify Gas Control of damage to pipeline in system that are remotely monitored that may need system pressure lowered in order to repair the damage.

6.0 Civil Disobedience

- 6.1 When an emergency results from sabotage, riot, or other forms of mob action, the Gas Supervisor shall:
 - 6.1.1 Protect the public and AIC's customers and personnel from injury due to possible damage to AIC's system.
 - 6.1.2 Protect AIC's system from possible damage.
- 6.2 At the first instance of civil disobedience, Gas Supervisor shall:
 - 6.2.1 Secure AIC's system in the area of the emergency by:
 - 1. Requesting police surveillance of critical gas facilities.
 - 2. Contacting Corporate Security to arrange for security guards.
 - 3. Assigning gas personnel to patrol the outskirts of the area including major regulator stations. Their function should only be for observing and reporting any developments in the area.
 - 6.2.2 If the potentially affected systems are remotely monitored, notify Gas Control of the situation.
 - 1. Discuss plans for isolating or shutting down sections of the system if the need arises.
 - 2. Develop a plan and line of communications for keeping all involved updated of the situation. See [Subsection 4.2](#).
 - 6.2.3 If violence or any threat to the safety of AIC's personnel persists:
 - 1. Withdraw AIC's personnel from the area.
 - 2. Notify law enforcement and Ameren Security.
 - 6.2.4 If the emergency remains unabated, take the necessary steps to sectionalize the area and shutdown that portion of the system.
 - 1. If Gas Control has verified they are remotely monitoring the systems, coordinate the isolation and/or shutdown process with them.
 - 6.2.5 Consider implementing other sections of the Emergency Plan as needed.
 - 6.2.6 Consider governmental reporting requirements. See [SAFT 1](#) and [INCD 1](#).

End of Instructions.

Operator Qualification (OQ) Required?

YES

A003: Emergency Response

UNCONTROLLED IF PRINTED

1371: Operate Gas Pipeline - System Control Center Operations

Appendices

NONE.

Attachments

NONE.

Compliance Requirements

49 CFR §192.615 Emergency plans.

Reference Documents

[INCD 1 Incident Reporting: Requirements](#)

[OQAL 2.01 Operator Qualification: Covered Task List](#)

[PTRL 2.2 Pipeline Patrols: Critical Area Patrols](#)

[REPR 1 Repairs: Requirements](#)

[SAFT 1 Safety Related Conditions: Requirements](#)

Document Rescission

EMER 2.5 Emergency Plan – Natural Disasters or Civil Disobedience, October 1, 2021

Revision Notes

Location of Changes	Summary of Changes
Paragraph 5.1.3 – Item 1	New - Service can be left on as long as the regulator and relief vent are extended above the expected high-water line
Paragraph 5.1.3 – Item 2	New - Gas meter will function when submerged, but the AMI device will require replacement following submergence.
Paragraph 5.1.4	Revised - Shutting off and locking individual services where regulator and relief vents could be submerged, with priority given to inside services.
Subsection 5.2	Title Change – During the Flood
Paragraph 5.2.7	Revised - Determine whether facilities (such as meter sets, regulator stations, valve stations, farm taps, and relief vent lines) that have become submerged could be struck by watercraft or floating debris.
Subsection 5.3	Title Change - Following the flood, the Gas Supervisor or GTS Supervisor, where applicable, shall ensure the following actions are taken.

<p>Paragraph 5.3.2</p>	<p>New - Replace AMI devices on all gas meters that were submerged during the flood.</p> <ol style="list-style-type: none">1. AMI can be replaced on the existing meter, OR2. Exchange the meter and ship to the Gas Meter Shop. The meter shall be tagged "Submerged"
<p>Paragraph 5.3.4</p>	<p>Moved from 5.1.5: Issue Warning Tag if:</p> <ol style="list-style-type: none">1. Water had covered the control valves on interior appliances, OR2. If service has been shut off. Refer to TURN 2.7 Warning Tag.
<p>Paragraphs 5.3.3 through 5.3.3 through 5.3.11</p>	<p>Grammatical – Created action verbs by removing "ing".</p>

EMERGENCY PLAN

October 1, 2021

EMER 2.6 Emergency Personnel and Materials

1.0 Purpose

This document outlines procedures for Ameren Illinois's (AIC's) availability of personnel, equipment, tools, and materials as needed at the scene of an emergency in accordance with 49 CFR §192.615.

2.0 Scope

This document addresses the following:

[3.0 Target Audience](#)

[4.0 Personnel, Storeroom, Specialized Tools and Equipment](#)

[5.0 Emergency Gas Material](#)

[6.0 Centralized Emergency Gas Material](#)

[7.0 Non-Centralized Emergency Gas Material](#)

3.0 Target Audience

- Gas Field Personnel
- Gas Supervisors
- Gas Tech Services (GTS) Supervisors
- Gas Tech Service (GTS) Personnel
- Storeroom Personnel
- Gas Engineering
- Gas Tech Engineering (GTE)

4.0 Personnel, Storeroom, Specialized Tools and Equipment (§192.615(a)(4))

4.1 The Gas Supervisor shall:

- 4.1.1 Maintain a list of available qualified personnel.
- 4.1.2 Ensure that the storeroom stocks an adequate quantity of emergency gas materials required for responding to and mitigating emergency situations.
- 4.1.3 Identify specialized tools and equipment needed for emergency situations.

5.0 Emergency Gas Material

5.1 The quantity and location of stocked emergency gas material is available through EM-PRV in the 607 storeroom.

6.0 Centralized Emergency Gas Material

6.1 The Gas Standards Engineer shall:

- 6.1.1 Determine what emergency gas material will be stored in each of the designated centralized storeroom locations.
- 6.1.2 Maintain a list of emergency gas material stored at centralized locations. The list is available on the Ameren Illinois Gas Operations SharePoint site, Standards & Materials.

UNCONTROLLED IF PRINTED

6.1.3 Inventory emergency gas material at centralized locations 1 time each calendar year.

6.2 Centralized emergency gas material shall include:

6.2.1 Steel pipe that is:

1. In sizes 2 through 30 inches.
2. Coated with fusion bond epoxy.
3. Pretested. See [PTST 1](#).
 - 3 a. Gas Tech Engineering (GTE) shall provide test pressures.
 - 3 b. Documentation of test pressure, date tested, medium used, duration of test, and witnesses shall be kept with each pipe joint.
4. In pipe joints of double random lengths.

6.2.2 Steel pipe fittings designated as emergency stock.

6.3 Storage requirements for centralized emergency gas material:

6.3.1 Stored at Decatur MDF:

1. In a separate location designated for emergency gas material.
2. Protected from ultraviolet light to prevent coating deterioration.

6.3.2 Steel pipe fittings designated as emergency stock shall be stored with their respective emergency gas material.

6.4 Regarding the use, replenishment, and verification of centralized emergency gas material, storeroom personnel shall:

- 6.4.1 After a request for emergency gas material is made, arrange for picking, loading, and shipping the required items.
- 6.4.2 Replace all material with like size and kind immediately after use through an automated process in EMPRV.
- 6.4.3 Verify that the minimum quantity of each item is on hand and properly stored.

7.0 Non-Centralized Emergency Gas Material

7.1 Non-centralized emergency gas material shall include:

7.1.1 PE pipe that:

1. Is pretested. See [PTST 1](#).
 - 1 a. Documentation of test pressure, date of test, medium used, duration of test and witness should be kept with each emergency plastic pipe segment.
2. Has the ends of the pipe covered, capped, or plugged to prevent debris from entering.
3. May have smaller diameter pipe stored inside larger diameter pipe to minimize storage.
4. Is stored for emergencies shall be inspected to ensure it does not exceed its shelf life.
 - 4 a. 3 years from the date of manufacture for PE 2708 (MDPE)

OR

4 b. 10 years from the date of manufacture for PE 4710 (HDPE).

7.1.2 Each operating area shall determine the minimum number and type of plastic and steel fittings to be kept in their local emergency inventory.

7.1.3 Steel pipe that is:

1. In sizes $\frac{3}{4}$ inch through 4 inches.
2. Up to 100 feet long for each size.
3. Coated with fusion bond epoxy.
4. Pretested. See [PTST 1](#).

4 a. Documentation of test pressure, date tested, medium used, duration of test, and witnesses shall be kept with each pipe joint.

5. Sealed at the ends of each pipe joint.
6. Stored in a location to prevent ultraviolet light from deteriorating the coating.

End of Instructions.

Operator Qualification (OQ) Required?

NO.

Appendices

NONE.

Attachments

NONE.

Compliance Requirements

49 CFR 192.615 Emergency plans.

Reference Documents

[PTST 1 Pressure Testing: Requirements](#)

Document Rescission

EMER 2.6 Emergency Plan: Emergency Personnel and Materials, October 1, 2020.

Revision Notes

Location of Changes	Summary of Changes
Paragraph 6.1.3	Inventory emergency gas materials at centralize locations 1 time each calendar year.

EMERGENCY PLAN

October 1, 2020

EMER 2.7 Emergency Response Review

1.0 Purpose

This document outlines procedures for Ameren Illinois's (AIC's) review of employee response to an emergency in accordance with 49 CFR §192.615.

2.0 Scope

This document addresses the following:

[3.0 Target Audience](#)

[4.0 General](#)

[5.0 Written Report](#)

Appendices:

[Appendix A - Sample Emergency Response Review Form](#)

3.0 Target Audience

- Gas Compliance Personnel
- Gas Supervisors
- Gas Tech Service (GTS) Supervisors
- Incident Commander
- Gas Storage Field Supervisor

4.0 General (§192.615(b)(3))

- 4.1 Following a declared natural gas emergency, the Incident Commander, Gas Superintendent / Supervisor or Gas Storage Field Superintendent / Supervisor shall conduct a formal review of the response to the emergency.
- 4.2 The review shall evaluate if the response of the personnel followed O&M Emergency Plan procedures.
- 4.3 In situations where the response of the personnel did not follow the procedures in the Emergency Plan, the response should be analyzed to determine the following:
 - 4.3.1 If the response was appropriate for the emergency situation.
 - 4.3.2 If the Emergency Plan needs to be updated to reflect this type of an emergency.
 - 4.3.3 If additional training on the Emergency Plan is required.

5.0 Written Report

- 5.1 A written report of the Emergency Response Review (see [Appendix A](#)) shall be completed for the following types of gas emergencies.
 - 5.1.1 Inside leak response with a hazardous concentration of gas (10% LEL or 0.5% gas in air or greater) involving multiple structures requiring evacuation by gas field personnel and/or Emergency Responder.
 - 5.1.2 Major leak or line break on high pressure distribution/transmission in a Class 3 or 4 location.

UNCONTROLLED IF PRINTED

- 5.1.3 Gas in a sewer migrating into a structure, with a hazardous concentration of gas (30% LEL or 1.5% gas in air or greater), requiring evacuation by gas field personnel.
 - 5.1.4 Fire, ignition, or explosion caused by a release of gas from AIC's facilities.
 - 5.1.5 Low pressure situation where 1000 people are interrupted for more than 24 hours.
 - 5.1.6 High pressure situation that results in a serious leak, fire, or explosion.
 - 5.1.7 Natural disaster declared by state or federal authorities that requires an emergency response by gas field personnel.
- 5.2 Send the written report to:
- 5.2.1 Manager - Pipeline Safety Compliance, 2125 E. State Route 104, Pawnee, IL 62558

End of Instructions.

Operator Qualification (OQ) Required?

NO.

Appendices

[Appendix A - Sample Emergency Response Review Form](#)

Attachments

NONE.

Compliance Requirements

49 CFR §192.615 Emergency plans.

Reference Documents

NONE.

Document Rescission

EMER 2.07 Emergency Plan: Emergency Response Review, January 1, 2018.

Revision Notes

Location of Changes	Summary of Changes
Not applicable.	This is a new document.

Appendix A - Sample Emergency Response Review Form

[\(View/download PDF version\)](#)

EMERGENCY RESPONSE REVIEW

DATE _____

LOCATION _____

SUPERVISOR _____

Emergency Description: _____

Employee's Response: _____

Response Variance to the Emergency Plan _____

Recommended Changes to the Emergency Plan _____

Additional Training Performed or Requested _____

EMERGENCY PLAN

October 1, 2020

EMER 2.8 Training

1.0 Purpose

This document outlines procedures for the emergency response training of Ameren Illinois' (AIC's) operating personnel in accordance with 49 CFR §192.615.

2.0 Scope

This document addresses the following:

[3.0 Target Audience](#)

[4.0 General](#)

[5.0 Initial Training](#)

[6.0 Refresher Training](#)

[7.0 Verification of Training Effectiveness](#)

3.0 Target Audience

- Gas Compliance Personnel
- Gas Training Personnel
- Gas Operator Qualification (OQ) Personnel
- Emergency Response Personnel
- Gas Field Personnel
- Gas Supervisors
- Gas Engineering
- Gas Storage Engineering (GSE)
- Gas Tech Engineering (GTE)
- Gas Tech Services (GTS) Supervisors
- Gas Tech Service (GTS) Personnel
- Gas Storage Field Supervisors
- Gas Storage Field Operators

4.0 General (§192.615(b)(2))

4.1 Personnel engaged in emergency response activities shall receive:

4.1.1 Initial training on the Emergency Plan.

4.1.2 Refresher training on the Emergency Plan.

4.2 AIC shall verify that the training is effective.

5.0 Initial Training

5.1 Initial Emergency Plan training is done during AIC's apprenticeship program. See [AP-PR](#).

6.0 Refresher Training

Refresher training ensures that personnel engaged in emergency response activities are knowledgeable about the current Emergency Plan.

6.1 Gas Supervisor shall ensure the refresher training is conducted during the first quarter of each year.

6.2 Gas Compliance Group shall send out an annual notification for the refresher training along with instructions and an Insight Roster.

UNCONTROLLED IF PRINTED

- 6.3 Each employee receiving the refresher training shall sign the Insight Roster.
- 6.4 Gas Supervisor or individual conducting the training shall sign and date the Insight Roster.
- 6.5 Gas Supervisor shall:
 - 6.5.1 Have the Insight Roster locally entered into Ameren's Insight program
OR
 - 6.5.2 Scan the Insight Roster and email it to the designated person at Pawnee Gas Training Center for entry into Ameren's Insight program.

7.0 Verification of Training Effectiveness

- 7.1 Training effectiveness is verified by:
 - 7.1.1 Examinations during AIC's apprentice and Operator Qualifications programs. See [APPR](#) and [OQAL](#).
 - 7.1.2 Post incident reviews. See [EMER 2.7](#).

End of Instructions.

Operator Qualification (OQ) Required?

NO.

Appendices

NONE.

Attachments

NONE.

Compliance Requirements

49 CFR §192.615 Emergency plans.

Reference Documents

[APPR Apprentice Training](#)

[EMER 2.7 Emergency Plan: Emergency Response Review](#)

Document Rescission

EMER 2.09 Emergency Plan: Refresher Training, October 1, 2011.

Revision Notes

Location of Changes	Summary of Changes
Not applicable.	This is a new document.

1.0 Purpose

This procedure provides information about Ameren Illinois's (AIC's) portable Compressed Natural Gas (CNG) trailers in accordance with 49 CFR Part 172.

2.0 Scope

This document addresses the following:

[3.0 Target Audience](#)

[4.0 General](#)

[5.0 CNG Trailers by Location and Capacity](#)

[6.0 Regulating and Relief Equipment](#)

[7.0 Other Equipment](#)

[8.0 CNG Filling Stations](#)

[9.0 CNG Cylinders](#)

[10.0 CNG Transportation Requirements](#)

[11.0 Using CNG Trailers](#)

[12.0 Instructions](#)

[13.0 Examples](#)

3.0 Target Audience

- Gas Engineering
- Gas Supervisors
- Gas Tech Services (GTS) Supervisors
- Gas Tech Services (GTS) Personnel
- HAZMAT Employees
- HAZMAT Drivers
- Gas Tech Engineering (GTE)

4.0 General

4.1 Use a CNG trailer to provide a temporary gas supply for:

4.1.1 One or more residential customers or a small commercial customer to prevent an outage and subsequent relights during:

1. An emergency affecting AIC facilities such as a meter, regulator station, farm tap, main, or service

OR

2. Scheduled work.

4.1.2 An uprate or a strength test in specific cases.

5.0 CNG Trailers by Location and Capacity

Table 1: CNG Trailer Information

UNCONTROLLED IF PRINTED

Trailer ID	Hitch Type	Region	Location	Cylinders	Capacity	Contact	Phone Number
80129	Pintle	North	Kewanee	20	8.1 MCF @ 3600 PSIG	Rick Dougherty	C:309-335-4870
CL0694	Pintle	North	Peoria	15	6.1 MCF @ 3600 PSIG		
1350-061 TS	Pintle	North	Peoria	16	47.6 MCF @ 3600 PSIG		
80130	Pintle	North	Decatur	20	8.1 MCF @ 3600 PSIG	Ian Carter	C: 217-671-2664
1350-063 TS	Pintle	North	Decatur	16	47.6 MCF @ 3600 PSIG		
CL0736	Pintle	North	Springfield	15	6.1 MCF @ 3600 PSIG		
1350-064 TS	Pintle	North	Springfield	16	47.6 MCF @ 3600 PSIG		
80060	Pintle	South	Belleville	20	8.1 MCF @ 3600 PSIG	Matt Klop-meyer	C: 618-578-9298
80061	Pintle	South	Belleville	20	8.1 MCF @ 3600 PSIG		
1350-062 TS	Pintle	South	Belleville	16	47.6 MCF @ 3600 PSIG		

Back-up Con- North Region: Kelly Coppernoll C: 309-264-4250 South Region: Gary
 tacts: Vaughn C: 217-341-1638



Figure 1: CNG Trailer 80129

6.0 Regulating and Relief Equipment

Table 2: CNG Trailer Regulating and Relief Information

Description	Regulator	Orifice	Spring Range (PSIG)	Typical Set Point (PSIG)	Relief	Spring Range (PSIG)	Typical Set Point (PSIG)
-------------	-----------	---------	---------------------	--------------------------	--------	---------------------	--------------------------

UNCONTROLLED IF PRINTED

HP/Special	Meco P Series		200	200	Fisher H-202	35 - 300	250
Distribution	Fisher 627	3/16"	35 - 80	55	Fisher 289P	30 -100	60
Distribution	Fisher 627	3/16"	15 - 40	25 - 30	Fisher 289H	15 - 50	30 - 35
Customer - pounds	CL31N	1/4"	1 - 20	2, 5, or 10	Fisher 289H	10 - 20	6, 10, or 15
Customer - Inches	B31R	1/4"	Inches	7" W.C.	Internal	2	2

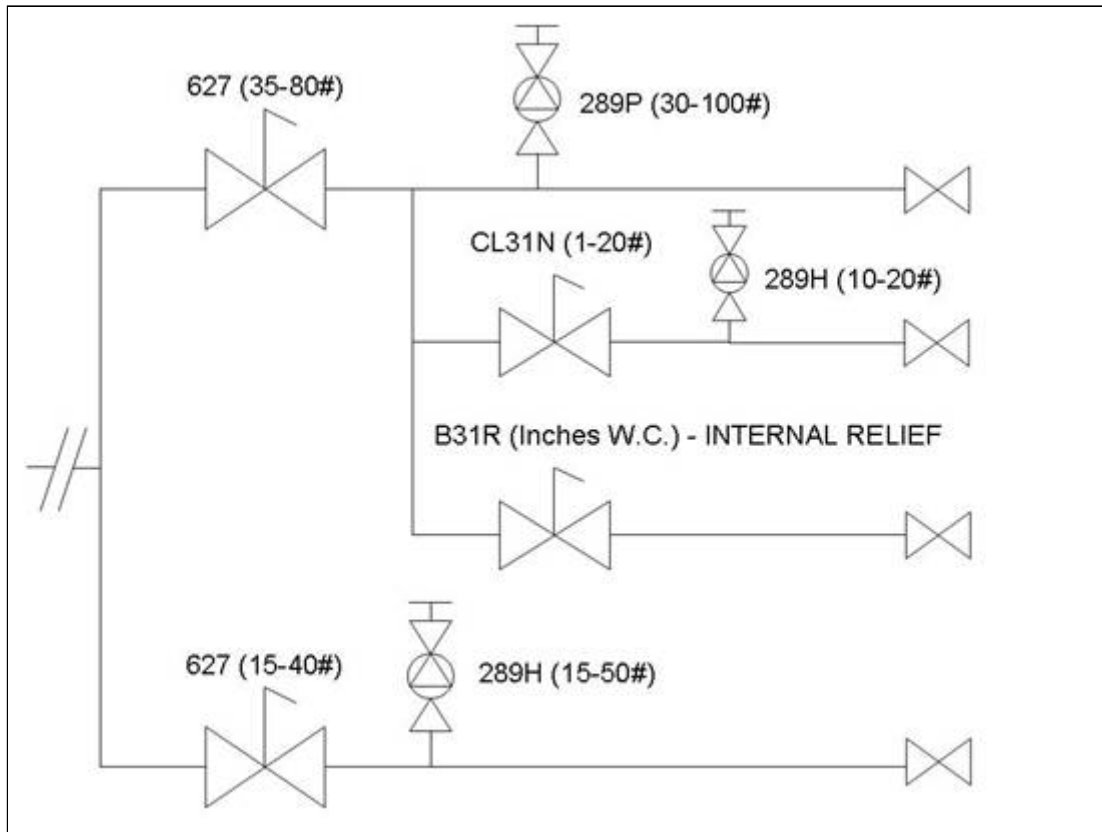

Figure 2: Typical Regulator Connections on CNG Trailers

1. Under special circumstances, full cylinder pressure can be made available from the filling tubing
2. Catalytic heaters provided on all trailers to prevent regulator freeze up.
3. Individual run configuration and physical appearance may vary from trailer to trailer.
4. GTE or GTS may approve the use of other pressure control equipment.

7.0 Other Equipment

7.1 Each trailer must also carry the following equipment:

7.1.1 A valved "Y" fitting to allow uninterrupted changing of trailers under load.

- 7.1.2 Minimum 50 feet of 1-inch rubber hose to tie into delivery location.
- 7.1.3 A static line to ground the trailer and prevent accidental ignition.
- 7.1.4 Fire Extinguisher, dry chemical (A. B. C.), 20 pound minimum.
- 7.1.5 Wheel chocks to be used when the trailer is in operation.
- 7.1.6 Miscellaneous fittings to connect to typical standards riser/meter set.
- 7.1.7 Minimum of 4 safety cones.

8.0 CNG Filling Stations

8.1 Refill CNG trailers in a timely fashion after use. See Table 3 for approved filling locations.

Table 3: Approved CNG Trailer Filling Locations

Company	Location	Address
Ameren Illinois	Edwards, IL	Peoria Gas OC, 7064 W Highway 150, Edwards, IL 61528
Ameren Illinois	Maryville, IL	2050 Vadalabene Drive Maryville, IL 62062
Springfield MTD	Springfield, IL	928 S. 9th St Springfield, IL 62703
Laclede Gas Company	Shrewsbury, MO	4118 Shrewsbury Ave Saint Louis, MO 63119
Peoria Disposal Company (PDC)	West Peoria, IL	1113 N. Swords Ave. West Peoria, IL 61604

9.0 CNG Cylinders

9.1 CNG cylinders shall be inspected and hydrostatically tested every 5 years by an approved testing facility.

10.0 CNG Transportation Requirements (49 CFR Part 172, Subpart C)

10.1 Properly fill out CNG Shipping Papers (see [EMER 3](#)) by entering:

- 10.1.1 The date, delivery address, and the route - if applicable.
- 10.1.2 The shipping name for CNG per 49 CFR §172.101 (see [EMER 3](#)):
 - 1. Methane, compressed
 - OR
 - 2. Natural gas, compressed (with high methane content).
- 10.1.3 The identification number of UN1971.
- 10.1.4 The hazard class of 2.1.
- 10.1.5 An "X" mark for Hazmat endorsement.
- 10.1.6 The signatures of the shipper and driver.

[EMER 3](#) (Shipping Paper for a CNG Trailer)

10.2 Additionally, shipping papers are required:

- 10.2.1 To remain within reach of the driver during transport.
- 10.2.2 Whether the tanks are full or empty.
- 10.2.3 To be retained for 2 years by GTS.

Contact GTS for more information about shipping papers.
Shipping papers are included in this manual; see [EMER 3](#).

10.3 HAZMAT Employees

10.3.1 HAZMAT employees shall be:

- 1. Trained and certified in accordance with §172.704 every 3 years.
- 2. Qualified in accordance with the Complex Pressure Control OQ to operate a CNG trailer.

10.3.2 HAZMAT drivers shall have a valid CDL with a HAZMAT endorsement to transport CNG trailers.

10.3.3 GTS shall keep a record of current training of each HAZMAT employee, inclusive of the preceding 3 years, for as long as that employee is an AIC HAZMAT employee and for 90 days thereafter.

10.4 Placarding CNG Trailers

10.4.1 Placards shall:

- 1. Have the identification number of 1971 and hazard class of 2.1.
- 2. Be displayed on all 4 sides of the trailer.
- 3. Be readily visible and not obscured.
- 4. Remain on the trailer even when the CNG cylinders are empty.

11.0 Using CNG Trailers

11.1 Determine the flow rate, pressure, and anticipated time of use requirements for the situation before using a CNG Trailer. Gas Engineering is available for assistance when using a CNG Trailer.

11.2 Rules of thumb for load/flow rate estimating:

11.2.1 The average residential customer has a maximum flow rate of 0.01 MCFH in summer.

11.2.2 Estimate a commercial or light industrial customer's flow rate using their connected equipment load or by contacting GTE or Gas Planning.

11.2.3 A CNG trailer has a maximum flow rate of 2.5 MCFH.

11.2.4 Use the integral catalytic heaters when:

- 1. The connected load exceeds 1,000 SCFH
- Or
- 2. Signs of freeze-up are observed.

UNCONTROLLED IF PRINTED

11.2.5 CNG trailers stationed at Belleville, Decatur, and Kewanee have 20 cylinders and hold about 8.1 MCF. CNG trailers stationed at Peoria and Springfield have 15 cylinders and hold about 6.1 MCF.

11.3 Use the Gas System Study books, prepared by Gas Planning, to estimate the load of an entire gas system. The books provide:

11.3.1 The maximum flow rate through a gas system's regulator station.

11.3.2 The number of customers assigned to a gas system.

11.4 Estimate a gas system's summer load (no space heating) equal to 10% of the gas system's flow rate shown in the Gas System Study books.

11.5 Use Table 4 or Table 5 below to estimate the volume of gas in a trailer by knowing the pressure on the cylinders and number of cylinders. The tables can be used to estimate the actual flow rate in the field.

Table 4: Trailer Volume vs Pressure: 20 Cylinders

Table 4: Trailer Volume vs Pressure: 20 Cylinders	
Trailer IDs: 80060, 80061, 80129, 80130	
Pressure (PSIG)	Volume (MCF)
3600	8.10
3500	7.88
3400	7.65
3300	7.43
3200	7.20
3100	6.98
3000	6.75
2900	6.53
2800	6.30
2700	6.08
2600	5.85
2500	5.63
2400	5.40
2300	5.18
2200	4.95
2100	4.73
2000	4.50
1900	4.28
1800	4.05
1700	3.83
1600	3.60
1500	3.38
1400	3.15
1300	2.93
1200	2.70
1100	2.48
1000	2.25
900	2.03
800	1.80
700	1.58
600	1.35
500	1.13
400	0.90
300	0.68
200	0.45
100	0.23
0	0.00

12.0 Instructions

- 12.1 Determine required flow rate, pressure set point, MAOP/MEP, and anticipated time of use requirements.
- 12.2 Determine which regulator/relief run is to be used (pressure required).
- 12.3 Determine where connection is to be made to system.
- 12.4 Ground trailer and attach static line to existing piping.
- 12.5 Connect trailer to system using the valved "Y" fitting provided. This allows trailers to be changed out without interruption if necessary. Leave valves at "Y" CLOSED.
- 12.6 OPEN all cylinder valves to supply gas (verify intended delivery pressure run is supplying gas).
- 12.7 Verify regulator and relief set points, adjust as necessary.
- 12.8 Transfer loads to CNG trailer by SLOWLY OPENING valve at "Y" fitting.
- 12.9 Secure and lock trailer to prevent unauthorized operation when left unattended.
- 12.10 Monitor trailer periodically for correct pressure and remaining capacity when utilized over long periods of time.
- 12.11 Pay close attention to regulator performance and watch for freeze-up. Light catalytic heaters if necessary.
- 12.12 If anticipated time of usage exceeds a single trailer's capacity, arrange for a 2nd trailer and complete [steps 4 through 9](#) to transfer load.

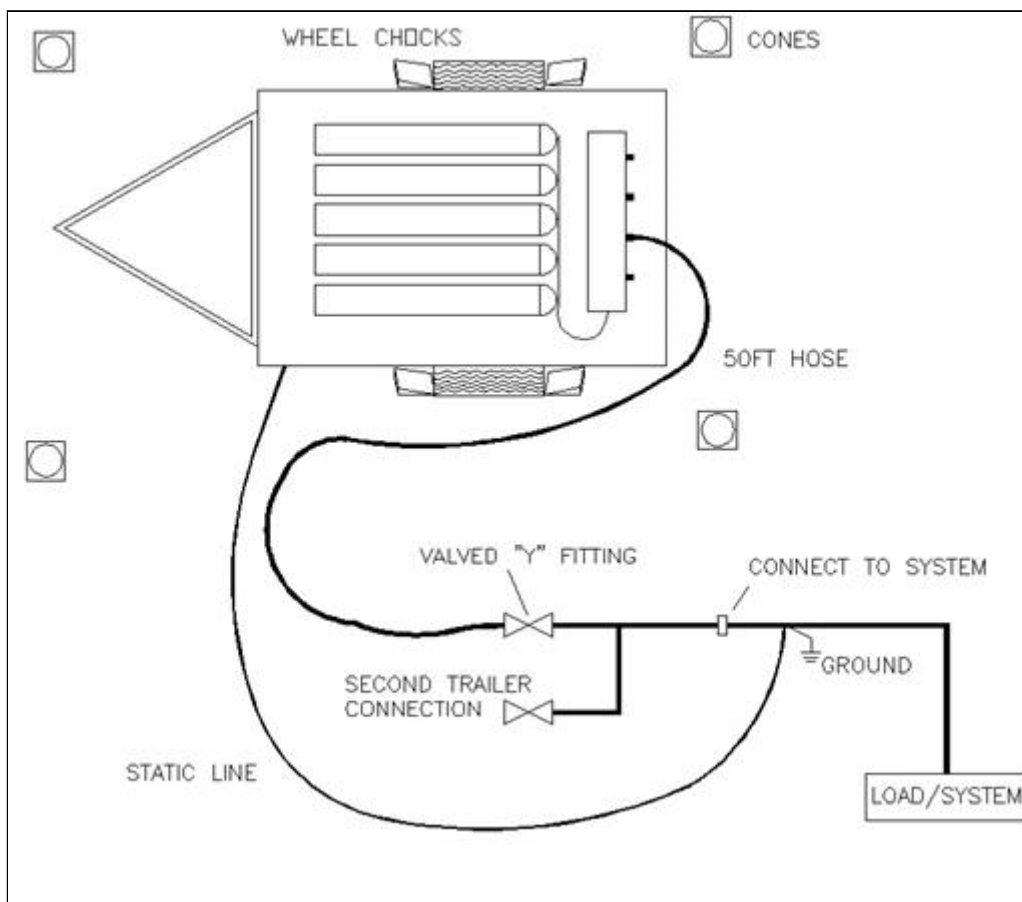

Figure 4: Typical CNG Trailer Application

13.0 Examples

UNCONTROLLED IF PRINTED

13.1 Can a CNG trailer be used to supply gas to a subdivision containing 65 homes during May when the temperature is about 70 °F? We want to maintain about 40 PSIG in the main feeding the subdivision.

$$(65 \text{ homes}) \times (0.01 \text{ MCF/home}) = 0.65 \text{ MCFH}$$

Yes: The 0.65 MCFH is less than the maximum flow rate of 2.5 MCFH of a CNG trailer.

13.2 Could a CNG trailer be used to supply the same 65 home subdivision on a winter "peak" day?

$$(65 \text{ homes}) \times (0.10 \text{ MCF/home}) = 6.50 \text{ MCFH}$$

No: The flow rate exceeds the maximum flow rate of a CNG trailer.

13.3 If a CNG trailer is brought out with 2800 PSIG in the cylinders, how long will it supply the load in Example 1?

From Table 4: trailer at 2800 PSIG has 6.3 MCF

$$(6.3 \text{ MCF}) \div (0.65 \text{ MCFH}) = \mathbf{9.69 \text{ Hours}}$$

From Table 5: trailer at 2800 PSIG has 4.7 MCF

$$(4.7 \text{ MCF}) \div (0.65 \text{ MCFH}) = \mathbf{7.23 \text{ Hours}}$$

13.4 If we would expect to replace the first CNG trailer with a second trailer when the pressure in the first trailer reaches 500 PSIG, how long would it take for the first CNG trailer to lower to 500 PSIG from 2800 PSIG?

From Table 4: trailer at 2800 PSIG has 6.3 MCF

trailer at 500 PSIG has 1.13 MCF

$$\text{Gas used} = 6.3 - 1.13 = 5.17 \text{ MCF}$$

$$(5.17 \text{ MCF}) \div (0.65 \text{ MCFH}) = \mathbf{7.95 \text{ Hours}}$$

From Table 5: trailer at 2800 PSIG has 4.7 MCF

trailer at 500 PSIG has 0.85 MCF

$$\text{Gas used} = 4.7 - 0.85 = 3.85 \text{ MCF}$$

$$(3.85 \text{ MCF}) \div (0.65 \text{ MCFH}) = \mathbf{5.92 \text{ Hours}}$$

13.5 If after 1 hour of use, a CNG trailer has dropped from 2800 to 2400 PSIG, what would the actual hourly rate of use be?

From Table 4: trailer at 2800 PSIG has 6.3 MCF (Starting Volume)

trailer at 2400 PSIG has 5.4 MCF (Ending Volume)

$$\text{Gas used} = 6.3 - 5.4 = \mathbf{0.9 \text{ MCFH}}$$

From Table 5: trailer at 2800 PSIG has 4.7 MCF (Starting Volume)

trailer at 2400 PSIG has 4.07 MCF (Ending Volume)

$$\text{Gas used} = 4.7 - 4.07 = \mathbf{0.63 \text{ MCFH}}$$

13.6 How many hours would be left in the trailer at the actual determined flow rate of 0.9 MCFH? Assume you can use the trailer down to 200 PSIG. The duration time should be adjusted for the actual usage flow rate.

From Table 4: trailer at 2400 PSIG has 5.4 MCF (Starting Volume)

trailer at 200 PSIG has 0.45 MCF (Ending Volume)

Gas available = 4.95 MCF

$(4.95 \text{ MCF}) \div (0.90 \text{ MCFH}) = \mathbf{5.5 \text{ Hours}}$

From Table 5: trailer at 2400 PSIG has 4.07 MCF (Starting Volume)

trailer at 200 PSIG has 0.34 MCF (Ending Volume)

Gas available = 3.73 MCF

$(3.73 \text{ MCF}) \div (0.90 \text{ MCFH}) = \mathbf{4.14 \text{ Hours}}$

13.7 Calculate the therms of gas it takes to fill a trailer if it has 700 PSIG in it before filling and it tops off at 3200 PSIG at a filling station. Reference (10 therms/MCF).

From Table 4: Volume @ 700 PSIG = 1.58 MCF

Volume @ 3200 PSIG = 7.20 MCF

Gas to fill = 7.20 - 1.58 = **5.62 MCF or 56.2 therms (added)**

From Table 5: Volume @ 700 PSIG = 1.19 MCF

Volume @ 3200 PSIG = 5.42 MCF

Gas to fill = 5.42 - 1.19 = **4.23 MCF or 42.3 therms (added)**

End of Instructions.

Operator Qualification (OQ) Required?

YES

4100: Complex Pressure Control (Pilot Operated Regulators and Reliefs)

Appendices

NONE.

Attachments

NONE.

Compliance Requirements

49 CFR Part 172 Subpart C - Shipping Papers

49 CFR §172.704 Training requirements.

Reference Documents

NONE.

Document Rescission

EMER 2.9 Emergency Plan: CNG Trailer, April 1, 2021.

Revision Notes

Location of Changes	Summary of Changes
---------------------	--------------------

UNCONTROLLED IF PRINTED

Section 5.0 Table 1 CNG Trailer Information	Rick Dougherty replaces Kelly Coppennoll as contact for Kewanee and Peoria.
Section 8.0 – CNG Filling Stations	Added CNG filling station at the Peoria Gas Operating Center in Edwards, IL.

EMERGENCY PLAN

October 1, 2021

EMER 2.10 Gas Control

1.0 Purpose

This procedure provides information about Ameren Illinois's (AIC's) Gas Control's response when there has been a loss of communication with or an alarm from a remotely monitored or controlled device.

2.0 Scope

This document addresses the following:

[3.0 Target Audience](#)[4.0 General](#)[5.0 Loss of Communication](#)[6.0 Alarm Management](#)

3.0 Target Audience

- Gas Engineering
- Gas Supervisors
- Gas Tech Services (GTS) Supervisors
- Gas Tech Service (GTS) Personnel
- Gas Control

4.0 General

- 4.1 AIC's Gas Control remotely monitors and controls specific gas facilities and pipeline interconnects to ensure that Ameren Illinois' gas system is operating safely and is providing an adequate and reliable supply of gas to Ameren Illinois customers.
- 4.2 Gas Control remotely monitors and controls such parameters as gas pressures, gas flow, odorization rates, and valve positioning within the Ameren Illinois gas transmission and distribution system along with gas being supplied by pipeline suppliers.
- 4.3 Monitored points have established alarm settings which provide an indication of an abnormal operation, potential problem or malfunction of equipment at that location or within the monitored system.
- 4.4 Gas Control provides further assistance to AIC's gas operations personnel in emergency situations, during major maintenance or construction activities, and inspection activities at the monitored gas facility that could affect the integrity or reliability of the gas system.
- 4.5 Since Gas Control remotely monitors and controls critical points of AIC's transmission and distribution gas systems. Required communications and coordination between operations personnel and Gas Control is included throughout the Ameren Illinois Gas O&M Plan.
- 4.6 Control Room Management Plan, a separate document, provides documentation and guidelines for the operations of Gas Control and Gas Control personnel. Once Gas Control personnel determine a situation requires operating personnel involvement, Gas O&M procedures will be followed.

5.0 Loss of Communications

UNCONTROLLED IF PRINTED

- 5.1 Remote monitoring and control of gas facilities is accomplished through SCADA equipment and the installation of electronic pressure recorders (ERXs)..
- 5.2 If communication is lost to these devices, Control Room personnel will determine the extent of the loss and the possible cause and duration of the loss.
 - 5.2.1 If the determination of the loss is isolated to a particular piece of equipment in the field, Control Room personnel will contact the appropriate GTS personnel or GTS Supervisor.
 - 5.2.2 GTS personnel may be dispatched to the site to determine the cause and, if possible, remedy the situation. Gas Control will be contacted to verify communications has been restored and normal operations has resumed.
 - 5.2.3 When immediate repairs cannot be made, GTS personnel will determine what is needed to correct the situation and schedule the repair. Gas Control will be notified of the findings and the plans for repair.
- 5.3 When SCADA indicates a monitoring, control or communications problem, GTS personnel may be dispatched to the site.
- 5.4 When the loss is determined to be wide spread or the conditions indicate a long duration,
 - 5.4.1 Gas Control may initiate Manual Operations per the CRM Plan, and/or initiate an EOC assessment call.
 - 5.4.2 During the EOC assessment call, a determination will be made for further actions, up to activation of the EOC, if necessary.

6.0 Alarm Management

- 6.1 Gas Control has alarm settings for devices they remotely monitor. The settings are established to provide safe and effective pipeline operations.
- 6.2 When Gas Control personnel have determined the alarm or indicated situation requires field investigation, the appropriate GTS personnel or GTS Supervisor are contacted.
 - 6.2.1 GTS personnel will go to the site to investigate the cause of the alarm and notify Gas Control upon their arrival at the site.
 - 6.2.2 Following the repair(s), Gas Tech Services personnel will notify Gas Control what repairs were made and that the alarm has been cleared.
 - 6.2.3 If the alarm(s) were due to a significant abnormal operation that could have had an impact on adjacent systems, Gas Control will monitor and review critical facilities in the adjacent systems to ensure the integrity of EACH associated gas system has not been compromised and their MEP has not been exceeded.
- 6.3 Alarms at an odorization station may indicate the odorizer is either injecting too much or too little odorant into the gas system or the odorizer has quit working.

End of Instructions.

Operator Qualification (OQ) Required?

YES

1371 Operate Gas Pipeline – System Control Center Operations

1381 Operate Gas Pipeline – Local Facility Remote Control Operation

UNCONTROLLED IF PRINTED

Appendices

NONE.

Attachments

NONE.

Compliance Requirements

Reference Documents

NONE.

Document Rescission

EMER 2.10 Emergency Plan: Gas Control, October 1, 2020.

Revision Notes

Location of Changes	Summary of Changes
1.0 Purpose	Clarified EMER 2.10 addresses Gas Control's response when there has been a loss of communication with or an alarm from a remotely monitored device.
Throughout the document	Added "and controls" where there was a reference to Gas Control remotely monitors.
Subsection 4.5 - General	Revised – Gas Control remotely monitors and controls critical points of AIC's transmission and distribution gas systems. Required communications and coordination between operations personnel and Gas Control is included throughout the Ameren Illinois Gas O&M Plan.
Paragraph 5.2.2 – Loss of Communications	GTS personnel may be dispatched to the site to remedy the situation.
Paragraph 5.2.3	When immediate repairs cannot be made, GTS personnel will determine what is needed to correct the situation and schedule the repairs.
Subsection 5.3	When SCADA indicated a monitoring, control or communications problem, GTS personnel may be dispatched to the site.
Subsection 5.4 and Paragraph 5.4.1	Grammatical – added "When", "or, and "may"
Subsection 6.2 – Alarm Management	Grammatical – added "When"
Paragraph 6.2.1	GTS personnel will go to the site to investigate the cause if the alarm and notify Gas Control upon their arrival at the site.
Paragraph 6.2.3	Gas Control will monitor and review critical facilities in the adjacent systems to ensure the integrity of EACH associated gas system has not been compromised and their MEP had not been exceeded.
Operator Qualifications	Added: 1371 Operate Gas Pipeline – System Control Center Operations 1381 Operate Gas Pipeline – Local Facility Remote Control Operation

UNCONTROLLED IF PRINTED

EMERGENCY PLAN

July 22, 2022

EMER 2.11 Gas Storage

1.0 Purpose

This procedure provides information about Ameren Illinois (AIC) Gas Storage's response to accidental releases, equipment failures, natural disasters, and third-party emergencies and is in accordance with 49 CFR § 192.12.

2.0 Scope

This document addresses the following:

[3.0 Target Audience](#)[4.0 General](#)[5.0 Accidental Releases from an Underground Natural Gas Storage Facility](#)[6.0 Equipment Failures at an Underground Natural Gas Storage Facility](#)[7.0 Natural Disasters](#)[8.0 Third Party Emergencies](#)**3.0 Target Audience**

- Gas Storage Engineering (GSE)
- Gas Storage Operations
- Gas Storage Supervisors
- Gas Tech Service (GTS)
- Gas Supply

4.0 General

- 4.1 AIC's Gas Storage monitors and operates 12 underground natural gas facilities to ensure that Ameren Illinois' gas system is operating safely and is providing an adequate and reliable supply of gas to Ameren Illinois customers.
- 4.2 This procedure outlines the requirements and corresponding steps to address emergency situations. This procedure identifies roles and responsibilities of individuals during an event.
- 4.3 Safety-related conditions shall be reported as defined in [SAFT 1 Section 4.3](#) Underground Storage Facilities and [SAFT 1 Appendix A](#).
- 4.4 Incident reporting shall be reported as defined in [INCD 1 Section 5](#) Natural Gas Incident.
- 4.5 Environmental considerations shall be made and addressed during an incident and documented.
 - 4.5.1 Refer to [Gas Storage Emergency Manual](#) for Emergency Spill Response actions and inventory of materials (Flammables) for each Storage facility.
 - 4.5.2 Refer to the [Blowout Contingency Plan \(WCERP\)](#) for accidental release response actions.

UNCONTROLLED IF PRINTED

- 4.6 Emergency responders and mutual assistance information for each underground natural gas storage facility is in the [Gas Storage Emergency Manual](#).
- 4.7 The Gas Storage Incident Management Team organizational chart identifies roles and responsibilities for emergency response. The Incident Management Team organizational chart is located on the Ameren Illinois Emergency Operations Center SharePoint site.
- 4.8 Employee training for the Gas Storage Emergency Response Plan is conducted annually not to exceed 15 months.

5.0 Accidental Release from an Underground Natural Gas Storage Facility

- 5.1 Accidental releases (gas escaping) are defined as controllable or uncontrollable incidents.
- 5.2 In the event of an accidental release (gas escaping) refer to the flow chart in the [Gas Storage Emergency Manual](#) to determine if the release is controllable or uncontrollable.
- 5.3 For a release determined to be a controllable incident, follow the steps for gas escaping in a controllable release.
- 5.4 For a release determined to be an uncontrollable incident, follow the steps for gas escaping in an uncontrollable release, which integrates the [Gas Storage Blowout Contingency Plan \(WCERP\)](#).
 - 5.4.1 Follow the steps in in the Initial Response Actions (Section 2) of the WCERP to determine the response level and actions.

6.0 Equipment Failures at an Underground Natural Gas Storage Facility

- 6.1 Equipment failure can occur on station equipment or well-related equipment.
- 6.2 In the event of station equipment failure refer to the flow chart in the [Gas Storage Emergency Manual](#) and follow the steps for Station/Plant Hazards.
- 6.3 In the event of well-related equipment failure, Gas Storage engineering will evaluate the incident and develop an action plan (procedure).

7.0 Natural Disasters

- 7.1 For natural disasters refer to [EMER 2.5](#) Natural Disasters and Civil Disobedience.

8.0 Third-Party Emergencies

- 8.1 In the event of a station emergency caused by a third party refer to the flow chart in the Gas Storage Emergency Manual and follow the steps for Station/Plant Hazards.
- 8.2 In the event of a well-related emergency caused by a third party, resulting in an uncontrollable incident, follow the steps in the Initial Response Actions (Section 2) of the WCERP to determine the response level and actions.

End of Instructions.

UNCONTROLLED IF PRINTED

Operator Qualification (OQ) Required?

YES

- A003 Emergency Response

Appendices

NONE.

Attachments

NONE.

Compliance Requirements

49 CFR §192.12: Underground Natural Gas Storage Facility

49 CFR §192.615: Emergency Plans

Reference Documents

[QQAL 2.1 Operator Qualifications: Covered Task List](#)

[QQAL 2.2 Operator Qualification: Covered Task AOC's](#)

[WIGE 2.1 Working in Gaseous Environment: Hazardous Environment](#)

[Blowout Contingency Plan \(WCERP\)](#)

[Gas Storage Emergency Manual](#)

Document Rescission

NONE

Revision Notes

Location of Changes	Summary of Changes
Not Applicable	This is a new document

EMERGENCY PLAN

April 1, 2023

EMER 3 Forms and Reference Materials

Click on the links below to open the documents.

Forms

1. [Emergency Response Review](#)
2. [Ameren Shipping Papers for CNG, Updated 03/21/2021](#)
3. [Emergency Gas Meter Status Record](#)

References

1. [Electric Cold Load Restoration Policy \(April 1, 2023\)](#)

End of Section.

Document Rescission

EMER 3 Emergency Plan – Forms and Reference Materials, October 1, 2022

Revision Notes

Location of Changes	Summary of Changes
Reference Material	Updated Electric Cold Load Restoration Policy (April 1, 2023)

EXCV-Excavation Safety

EXCAVATION SAFETY

October 1, 2022

EXCV 0 Table of Contents

EXCV 1 Requirements

Section 1.0 Purpose

Section 2.0 Scope

Section 3.0 Target Audience

Section 4.0 Excavations

Section 5.0 Sloping and Benching Protective System

Section 6.0 Shoring or Shields Protective System

Section 7.0 Soil Classification

Operator Qualification (OQ)

Compliance Requirements

Reference Documents

Document Rescission

EXCV 2.1 Prior to Excavation

Section 1.0 Purpose

Section 2.0 Scope

Section 3.0 Target Audience

Section 4.0 Job Site Inspection

Section 5.0 Job Preparation

Operator Qualification (OQ)

Compliance Requirements

Reference Documents

Document Rescission

EXCV 2.3 Work in Excavation

Section 1.0 Purpose

Section 2.0 Scope

Section 3.0 Target Audience

Section 4.0 Beginning Excavation

Section 5.0 Inspection of Excavation

UNCONTROLLED IF PRINTED

Section 6.0 Working in Excavation

Operator Qualification (OQ)

Compliance Requirements

Reference Documents

Document Rescission

EXCV 2.4 Soil Analysis & Classification

Section 1.0 Purpose

Section 2.0 Scope

Section 3.0 Target Audience

Section 4.0 Visual Analysis

Section 5.0 Manual Analysis

Section 6.0 Soil Classification

Section 7.0 Destabilizing Factors

Section 8.0 Excavation/Soils Checklist

Operator Qualification (OQ)

Compliance Requirements

Reference Documents

Document Rescission

EXCV 2.5 Sloping Protective System

Section 1.0 Purpose

Section 2.0 Scope

Section 3.0 Target Audience

Section 4.0 General

Section 5.0 Sloping Protective System

Section 6.0 Typical Sections for Different Soil Configurations

Operator Qualification (OQ)

Compliance Requirements

Reference Documents

Document Rescission

EXCV 2.6 Sloping & Benching Protective System

Section 1.0 Purpose

Section 2.0 Scope

Section 3.0 Target Audience

Section 4.0 General

Section 5.0 Sloping & Benching Protective System

Section 6.0 Excavation in Type A Soil

Section 7.0 Excavation in Type B Soil

Operator Qualification (OQ)

Compliance Requirements

Reference Documents

Document Rescission

EXCV 2.7 Aluminum Hydraulic Shoring Protective System

Section 1.0 Purpose

Section 2.0 Scope

Section 3.0 Target Audience

Section 4.0 General

Section 5.0 Hydraulic Shoring

Section 6.0 Typical Sections for Hydraulic Shoring

Operator Qualification (OQ)

Compliance Requirements

Reference Documents

Document Rescission

EXCV 2.8 Trench Box Protective System

Section 1.0 Purpose

Section 2.0 Scope

Section 3.0 Target Audience

Section 4.0 General

Section 5.0 Trench Box Protective System

Section 6.0 Typical Trench Box

Section 7.0 Typical Sections for Trench Box Installation

Operator Qualification (OQ)

Compliance Requirements

Reference Documents

Document Rescission

EXCV 2.9 Working in Hazardous Environment

Section 1.0 Purpose

Section 2.0 Scope

Section 3.0 Target Audience

Section 4.0 General

Section 5.0 Prior to Beginning Work

Section 6.0 Entering Excavation

Section 7.0 Hazardous Concentration of Natural Gas – Level 1 PPE Requirement

Section 8.0 Hazardous Concentration of Natural Gas – Level 2 PPE Requirement

Operator Qualification (OQ)

Compliance Requirements

Reference Documents

Document Rescission

EXCV 4 Forms and Reference Materials

Reference

Speed Shore's Vertical Shores Tabulated Data

Speed Shore's Shoring Shields Tabulated Data

Speed Shore's Aluminum Panel Shields Tabulated Data

Speed Shore's MAPS-B Tabulated Data

Document Rescission

End Table of Contents.

Document Rescission

EXCV 0 Excavation Safety: Table of Contents, October 1, 2020.

Revision Notes

Location of Changes	Summary of Changes
Entire document	Reformatted to match the October 1, 2020 re-write format

EXCAVATION SAFETY

October 1, 2022

EXCV 1 Requirements

1.0 Purpose

1. Procedures are required to provide for safety during maintenance and operations activities which includes taking adequate precautions in excavated trenches to protect personnel from the hazards of cave-ins, traffic and equipment, falling loads, or hazardous environment.
2. Excavation safety is regulated under the Occupational Safety and Health Administration (OSHA) Part 1926 Safety and Health Regulations for Construction. Ameren Illinois (AIC) Safety Department is responsible for administering OSHA regulations. AIC's Safety Supervisors should be contacted with questions or concerns with excavation safety.
3. The Pipeline Hazardous Materials Safety Administration (PHMSA) under §192.605 (b)(9) does require protection of personnel from hazards of unsafe accumulations of vapors or gas in an excavation.

2.0 Scope

This document addresses the following:

[3.0 Target Audience](#)[4.0 Excavations](#)[5.0 Sloping an Benching Proctive System](#)[6.0 Shoring or Shields Protective Systems](#)[7.0 Soil Classification](#)

3.0 Target Audience

- Gas Field Personnel
- Gas Supervisors
- Gas Tech Services (GTS) Personnel
- Gas Tech Services (GTS) Supervisors
- Gas Storage Field Personnel
- Gas Storage Field Supervisors
- Gas Construction Services personnel
- Gas Construction Services Supervisors

4.0 Excavations

- 4.1 Excavations 4 feet or more in depth shall have an adequate means for workers to safely enter and exit with no more than 25 feet of lateral travel from any location where people are working.
- 4.2 Excavations 5 feet or more in depth, or excavations of any depth where the Competent Person determines that a cave-in hazard to personnel exists, shall be protected from cave-ins by sloping, benching, and/or shoring/shielding, as appropriate for the soil type(s) before personnel are allowed to enter.

UNCONTROLLED IF PRINTED

- 4.3 Excavations 20 feet or more in depth require the excavation protection system be designed by a registered professional engineer.
- 4.4 Emergency rescue equipment such as breathing apparatus, a safety harness and lifeline or a basket stretcher, must be readily available where hazardous environment conditions exist or may reasonably be expected to develop during work in an excavation as required under §192.605 (b)(9).
- 4.5 Excavations in which personnel will enter shall be inspected daily by the Competent Person for evidence of a situation that could result in possible cave-in, indications of failure of protective systems, hazardous environment, or other hazardous conditions.
 - 4.5.1 If the Competent Person finds evidence of a situation that could pose a threat to the safety of the employees, exposed employees will be removed from the hazardous area until necessary precautions have been taken to ensure their safety.

5.0 Sloping and Benching Protective System

- 5.1 Each employee shall be protected from cave-ins by an adequate protective system except where:
 - 5.1.1 The excavation is in stable rock.
 - 5.1.2 The excavation is less than 5 feet in depth and based on Competent Person examination there is no indication of potential cave-in.
- 5.2 Sloping and benching system configurations shall be selected and constructed based on results of soil classification, a visual examination of the area, adjacent activities that may affect the stability of soil, or soil that is part of a layered system.
- 5.3 Excavations of less than 20 feet in depth shall be sloped at an angle not steeper than one and one-half horizontal to one vertical (1-1/2H : 1V) or 34 degrees measured from horizontal unless the soil has been classified as Type A or Type B.
- 5.4 Benching configuration is dependent on soil type, Type A or Type B and depth of excavation.
- 5.5 Benching is not an adequate protection system in Type C soils.
- 5.6 Sloping or benching for excavation greater than 20 feet in depth shall be designed by registered professional engineer.

6.0 Shoring or Shields Protective System

- 6.1 Design of support system or shields system that are drawn from manufacturer's tabulated data shall be in accordance with all the specifications, recommendations, and limitations issued or made by the manufacturer.
- 6.2 Deviations from the specifications, recommendations, and limitations issued or made by the manufacturer shall only be allowed after manufacturer issues specific written approval.
- 6.3 Support systems shall be installed and removed in a manner that protects employees from cave-ins, structural collapse, or from being struck by members of the support system.
- 6.4 Shields shall be installed in a manner to restrict lateral or other hazardous movement of the shield in the event of the application of sudden lateral forces.

7.0 Soil Classification

- 7.1 A qualified Competent Person shall inspect every excavation and protective system for evidence of potential cave-in or failure of protective system.
- 7.2 The Competent Person is required to perform a soil analysis and soil classification to determine the potential for cave-in of an excavation, and to determine the appropriate protective measures, such as sloping, benching, shoring or shielding (trench) box to be utilized.
- 7.3 The soil classification must include both visual and manual tests. Refer to AIC Field Safety Manual, Section 33.0 Excavations available on the AIC Safety SharePoint site.

End of Instructions

Operator Qualification (OQ) Required?

NO

Appendices

NONE

Attachments

NONE

Compliance Requirements

NONE

Reference Documents

AIC Field Safety Manual, Section 34.0 Excavations. Available on the AIC Safety SharePoint site.

Document Rescission

EXCV 1 Excavation Safety: Requirements, October 1, 2021

Revision Notes

Location of Changes	Summary of Changes
Entire document	Minor spelling and grammar mistakes. Converted old format into new template for this excluded rewrite section.
1.0 Scope – Item 2	Revised - Excavation safety is regulated under the Occupational Safety and Health Administration (OSHA) Part 1926 Safety and Health Regulations for Construction. Ameren Illinois (AIC) Safety Department is responsible for administering OSHA regulations. AIC's Safety Supervisors should be contacted with questions or concerns with excavation safety.

<p>1.0 Scope – Item 3</p>	<p>New - The Pipeline Hazardous Materials Safety Administration (PHMSA) under §192.605 (b)(9) does require protection of personnel from hazards of unsafe accumulations of vapors or gas in an excavation.</p>
<p>Subpart 4.4</p>	<p>Grammatical - "environment" replaces "atmosphere" Added reference to §192.605 (b)(9).</p>
<p>Paragraph 5.1.2</p>	<p>Grammatical - Added "feet" – 5 feet</p>
<p>Subsection 7.3 Soil Classification</p>	<p>Added - Refer to AIC Field Safety Manual, Section 33.0 Excavations available on the AIC Safety SharePoint site.</p>

EXCAVATION SAFETY

October 1, 2022

EXCV 2.1 Prior to Excavation

1.0 Purpose

This document outlines the inspection and preparation to be taken before excavation begins.

2.0 Scope

This document addresses the following:

[3.0 Target Audience](#)

[4.0 Job Site Inspection](#)

[5.0 Job Preparation](#)

3.0 Target Audience

- Gas Field Personnel
- Gas Supervisors
- Gas Tech Services (GTS) Personnel
- Gas Tech Services (GTS) Supervisors
- Gas Storage Field Personnel
- Gas Storage Field Supervisors
- Gas Construction Services personnel
- Gas Construction Services Supervisors

4.0 Job Site Inspection

4.1 A Competent Person should be designated for the project.

4.2 The Competent Person should inspect the area of proposed excavation for situations or conditions that may pose a potential hazard to the excavation such as traffic, surface water movement, underground and overhead utilities, surface structures or recent construction activity.

5.0 Job Preparation

5.1 A Job Site Briefing shall be completed prior to beginning work.

5.2 Underground utilities shall be located and exposed preferably by hand or vacuum excavation when crossing or working within the tolerance zone. Machine excavating may be utilized in accordance with AIC Field Safety Manual provisions in Section 33.4 Work Within the Tolerance Zone. Available on the AIC Safety SharePoint site.

5.3 Vehicles and equipment not involved in excavation should be parked away from the excavation site to minimize surcharge load on excavation walls.

5.4 When necessary, measures should be taken to prevent vehicles and equipment from inadvertent entry into excavation by the use of barricades, stop logs, or spotter.

UNCONTROLLED IF PRINTED

5.5 Engine exhausts should be kept away from the excavation opening.

5.6 A fire extinguisher shall be on the jobsite when excavating around a gas line.

5.7 When required, the proper traffic control shall be in place.

5.8 Gas field personnel shall be aware of potential ignition sources and keep the work site safe from an accidental ignition. Refer to [ACIG 2.1](#) Work Area Protection

End of Instructions

Operator Qualification (OQ) Required?

YES

1291 Locate Underground Pipelines

1321 Damage Prevention During Excavation Activities by or on Behalf of the Operator

1341 Provide or Assure Adequate Pipeline Support During Operator Initiated Excavation Activities

Appendices

NONE

Attachments

NONE

Compliance Requirements

NONE

Reference Documents

[ACIG 2.1 Accidental Ignition: Work Area Protection](#)

AIC Field Safety Manual, Section 33.0. Available on the AIC Safety SharePoint site.

Document Rescission

EXCV 2.01 Excavation Safety: Prior to Excavation, October 1, 2021

Revision Notes

Location of Changes	Summary of Changes
Entire document	Reformatted to match the October 1, 2020 re-write format
Subsection 5.2	Updated the reference and link to the AIC Field Safety Manual
Subsection 5.4	Separated from Subsection 5.3.

UNCONTROLLED IF PRINTED

	<p>Grammatical - When necessary, measures should be taken to prevent vehicles and equipment from inadvertent entry into excavation by the use of barricades, stop logs, or spotter.</p>
--	---

EXCAVATION SAFETY

October 1, 2022

EXCV 2.3 Work in Excavation

1.0 Purpose

This section outlines procedures to follow to ensure the safety of the individual while working in an excavation.

Any excavation in which vapors or gases could accumulate shall be checked for combustible gas concentration before allowing anyone in the excavation in accordance with §192.605 (b) (9).

2.0 Scope

This document addresses the following:

[3.0 Target Audience](#)

[4.0 Beginning Excavation](#)

[5.0 Inspection of Excavation](#)

[6.0 Working in Excavation](#)

3.0 Target Audience

- Gas Field Personnel
- Gas Supervisors
- Gas Tech Services (GTS) Personnel
- Gas Tech Services (GTS) Supervisors
- Gas Storage Field Personnel
- Gas Storage Field Supervisors
- Gas Construction Services personnel
- Gas Quality Assurance Consultants

4.0 Beginning Excavations

4.1 As excavation begins, the Competent Person should watch for the following:

4.1.1 Soil that remains as a clump as it is deposited indicates the soil is cohesive.

4.1.2 Soil that breaks up easily as it is deposited indicates a more granular soil.

4.1.3 Moisture content of the soil as the excavation gets deeper. Watch for water standing or running into the excavation.

4.1.4 Possibility the soil material has been previously disturbed which will affect the stability of the sides of the excavation.

4.1.5 Layers sloping into excavation.

4.2 Observing these items will aid in the classification of the soil type.

4.3 Gas field personnel shall not be allowed to stand under loads being lifted or deposited by excavating equipment

UNCONTROLLED IF PRINTED

- 4.3.1 Gas field personnel assigned to spot for the digging machine operator should exit the excavation while digging is in progress and remain outside the swing radius of the equipment.
- 4.3.2 Digging equipment operator should set their bucket on the ground when there are gas field personnel in the excavation.
- 4.4 Protect workers and public from falls into the excavation or contact with construction equipment and materials. General considerations would include:
 - 4.4.1 Depth of excavation.
 - 4.4.2 Proximity to roadways.
 - 4.4.3 Proximity to pedestrian routes.
 - 4.4.4 Length of time excavation will be left open
- 4.5 When working near roads or sidewalks, the following precautions should be followed:
 - 4.5.1 Pedestrians should not be led into direct conflicts with work site vehicles, equipment, or operations.
 - 4.5.2 Rope off all work areas with a barricade/caution tape or equivalent and place tape or equivalent to designate a safe pedestrian walkway around obstructions, such as ditches, holes, tool carts, trailers, or piles of dirt on sidewalks.
 - 4.5.3 Pedestrians should be provided with a safe, convenient travel path that replicates as nearly as possible the standard sidewalk or footpath.
 - 4.5.4 Consideration should be made to separate pedestrian movements from both worksite activity and motor vehicle traffic.
 - 4.5.5 Pedestrians should be appropriately directed with advance signing that encourages them to cross to the opposite side of the roadway.
 - 4.5.6 Whenever it is feasible, closing off the work site from pedestrian intrusion may be preferable to channelizing pedestrian traffic along the site with temporary traffic control devices.
- 4.6 Spoils are always required to be a minimum of 2 feet from the edge of excavation.
 - 4.6.1 This will protect personnel from loose soil material that could fall into the excavation.
 - 4.6.2 The excavating equipment operator should scale or sweep the excavation face to eliminate loose material that could fall into the excavation and injure a worker.
- 4.7 All foreign underground utilities within 18 inches of the proposed excavation shall be uncovered preferable by hand digging or vacuum excavation prior to beginning the excavation. Machine excavating may be utilized in accordance with AIC Field Safety Manual, Section 33.4 Subsurface Utility Protection, <https://ameren.sharepoint.com/sites/IL-Safety>.
- 4.8 Underground facilities that are within the excavation shall be protected by hand shoveling the material away from the facility so the digging equipment's bucket can remain away from the facility.
- 4.9 Pipes exposed in the excavation shall be supported to avoid excessive sagging.
 - 4.9.1 If a significant length of pipe(s) is exposed - notify the utility owner of the pipe.
 - 4.9.2 Water and Sewer line joints should be supported to prevent pull-out or blow-out.

4.9.3 Notify utility owner if there has been any damage done to their pipe, pipe coating, or tracer wire.

4.9.4 Gas lines should be supported and inspected to ensure:

1. No damage to the coating or the pipe.
2. Pipe is not in undue stress.
3. Refer to [MAIN 2.4](#) Temporary Pipeline Support.

4.9.5 Supports should be free from sharp edges.

4.9.6 Backfilling operations should be carefully done and the backfill material should be compacted under the pipes before any supports are removed.

4.10 Cables can be supported by means of ropes to avoid excessive sagging. Cable owners should be notified of any damage to their cable or cable coating.

4.11 Neither exposed pipe nor cable should be supported by, hung from, or over gas piping.

5.0 Inspection of Excavation

5.1 If there is a potential for gas accumulation, the excavation shall be checked with a gas detector for combustible gas concentration before allowing anyone in the excavation.

5.2 The Competent Person is required to inspect all excavations and complete an "Excavation / Soils Checklist" each day an excavation is left open and workers are entering the excavation.

5.3 Additions/changes to the "Excavation / Soils Checklist" are required whenever there is a change in the soil characteristic of an excavation that could affect the stability of the excavation.

5.4 The Competent Person will perform an initial soil classification of the excavation material by performing at least one visual and one manual analysis test.

6.0 Working in Excavation

6.1 Excavations deeper than 4 feet shall have a means for workers to enter and exit.

6.2 The means to enter or exit shall be located no more than 25 feet laterally from any worker.

6.3 Acceptable means for providing access to and from an excavation are:

6.3.1 Constructing ramps at either end of excavation or within 25 feet of any worker whichever is less.

1. Ramps must be flat enough so a worker can walk out of the excavation unassisted.
2. Workers should not have to climb out on their hands and knees or use knotted ropes.
3. Ramps must not have slip or trip hazards.

6.3.2 Providing a ladder that is labeled as meeting OSHA requirements.

1. Ladder must extend 3 feet beyond point of contact with side of excavation and be secured to prevent movement.

6.3.3 Steps cut into the side of the excavation.

1. Steps must not have slip or trip hazards.

UNCONTROLLED IF PRINTED

2. Steps must be cut into stable soil.
 3. Steps must be a minimum of 12 inches in depth or deep enough so that the employee's foot is completely supported by the step.
 4. Steps must be wide enough for both of the individual's feet to stand on the step.
 5. The rise of the steps must be wide enough for both of the individual's feet to stand on the step.
 6. Toe holes in the side of excavation are not acceptable steps.
- 6.4 Excavations 5 feet and deeper, or excavations of any depth where a cave-in hazard to personnel exists, shall have a properly designed protective system to protect workers from a cave-in.
- 6.4.1 The Competent Person will determine the appropriate protective system.
 - 6.4.2 The acceptable protective system is dependent on the soil type and size of excavation.
 - 6.4.3 Acceptable protective system are:
 1. Sloping.
 2. Sloping and Benching.
 3. Aluminum Hydraulic Shoring.
 4. Trench Box.
 - 6.4.4 Gas field personnel are not permitted to enter the excavation until the protective system is in place.
- 6.5 Excavations that are 20 feet or greater in depth require a protective system designed by a registered professional engineer.
- 6.6 When workers are present in excavations 5 feet and deeper, there should be at least one worker on the surface who, under ordinary circumstances, should not leave the work location.
- 6.7 Gas field personnel shall not work in excavations where there is accumulating or accumulated water unless:
- 6.7.1 The water is diverted around the excavation.
 - 6.7.2 The water is removed from the excavation. The water removal equipment should be monitored on a regular basis to ensure proper operation.
- 6.8 Gas field personnel should use hand or mechanical signals to prevent equipment from inadvertently entering the excavation.
- 6.9 If the situation warrants, a barrier should be installed along the edge of the excavation to prevent equipment or material from coming into the excavation.
- 6.10 Sidewalks, pavements, and other hard surfaces should not be undermined unless a support system or other method of protection is provided to protect the workers from possible collapse.
- 6.11 Prior to leaving the jobsite, any open excavation should be fenced or barricaded to prevent unauthorized access.

End of Instructions

UNCONTROLLED IF PRINTED

Operator Qualification (OQ) Required?

YES

1241: Outside Gas Leak Investigation

1341: Provide or Assure Adequate Pipeline Support During Operator Initiated Excavation Activities

Appendices

NONE

Attachments

NONE

Compliance Requirements

§192.605 (b)(9) Procedural Manual for Operations, Maintenance, and Emergencies.

Reference Documents

AIC Field Safety Manual, Section 33.4 Working Within the Tolerance Zone. Available on the AIC Safety SharePoint site.

AIC Field Safety Manual, Section 34.0 Excavations. Available on the AIC Safety SharePoint site.

Document Rescission

EXCV 2.03 Excavation Safety: Working in Excavation, December 1, 2020

Revision Notes Location	Summary of Changes
Varying locations throughout	Minor punctuation mistakes and spelling errors fixed. Reformatted to match the October 1, 2020 re-write format
1.0 Purpose	New - Any excavation in which vapors or gases could accumulate shall be checked for combustible gas concentration before allowing anyone in the excavation in accordance with §192.605 (b)(9).
Subsection 4.7	Revised reference link to IL Safety Manual
Paragraph 4.9.4 – Item 3	Added reference to MAIN 2.4 Temporary Pipeline Support
Subsection 6.11 – Excavation left open	Added open excavations should be fenced or barricaded

1.0 Purpose

A Competent Person must perform at least one visual and one manual analysis in order to classify the deposits from the excavation. This is done to determine the soil type(s) within the excavation.

2.0 Scope

This document addresses the following:

[3.0 Target Audience](#)

[4.0 Visual Analysis](#)

[5.0 Manual Analysis](#)

[6.0 Soil Classification](#)

[7.0 Destabilizing Factors](#)

[8.0 Excavation/Soils Checklist](#)

3.0 Target Audience

- Gas Engineering
- Gas Field Personnel
- Gas Supervisors
- Gas Tech Services (GTS) Personnel
- Gas Tech Services (GTS) Supervisors
- Gas Storage Field Personnel
- Gas Storage Field Supervisors
- Gas Construction Services personnel

4.0 Visual Analysis

4.1 A Visual analysis is conducted to determine the quality of the soil in and adjacent to the excavation.

4.2 The Competent Person should use all of the following Visual Analysis tests that apply:

4.2.1 Observe a sample of the soil as it is excavated.

1. Soil that remains in clumps is cohesive.
2. Soil that breaks apart is granular.

4.2.2 Observe the soil grain in a handful of the sample.

1. Fine grain soil is cohesive.
2. Coarse grain soil is granular.

- 4.2.3 Observe the sides of the excavation for fissures. Fissures are natural or man-made faults/cracks in the soil. Crack-like openings in the side walls or chunks of soil spalling or flaking off are an indication of fissured material.
- 4.2.4 Observe the excavation for signs of bulging, boiling, or sloughing.
- 4.2.5 Observe the side of the excavation to see if the soil is layered.
 - 1. Each layer will need to be classified in the excavation.
 - 2. Determine if layers slope toward the excavation.
- 4.2.6 Observe the area in and around the excavation for evidence of previously disturbed soil.
- 4.2.7 Observe the area in and around the excavation for signs of water accumulation or water seepage from the sides of the excavation.
- 4.2.8 Observe the area around the excavation for heavy traffic or other signs of vibration.

5.0 Manual Analysis

5.1 The Competent Person should use one of the following Manual Analysis tests:

5.1.1 Test for Plasticity:

- 1. Most soils are a mixture of cohesive and granular materials. The goal of plasticity testing should be to determine the sensitivity of the soil to water content change.
 - 1 a. Soils with high plasticity will remain cohesive and maintain their strength over a wider range of water content.
 - 1 b. Soils with low plasticity will be very sensitive to water content changes and will lose their strength quickly, such as during rainy conditions.
- 2. Mold a moist or wet soil sample, free of large granular material, into a ball and then roll it into a 2" long 1/8" diameter thread.
- 3. If the thread can be held on one end without breaking, the soil is cohesive and has high plasticity.
- 4. If the sample breaks or cannot be rolled into a thread, the soil has low plasticity.

5.1.2 Dry Strength Test:

- 1. Handle and observe a dry clump of the soil to see how it breaks apart.
- 2. If the clump crumbles on its own or with moderate pressure, the sample can be considered granular.
- 3. If it breaks into clumps, but is harder to break into small clumps, it may be clay in combination with a granular soil.
- 4. If the soil breaks into clumps but does not break into smaller clumps without difficulty and there are no signs of fissures, it can be considered cohesive.

5.1.3 Unconfined Compressive Strength Test:

1. Thumb Penetration Test:

- 1 a. Using a relatively large sample of moist soil, insert thumb in the soil and observe depth of penetration. Do not test near the edge of the sample.

UNCONTROLLED IF PRINTED

- 1 b. Full thumb penetration indicates a weak Type C soil.
- 1 c. A moderate thumb penetration of 1" indicates a slightly stronger soil, possibly Type B.
- 1 d. None to slight thumb penetration indicates a strong soil that has high resistance to shearing, Type A.
2. Pocket Penetrometer Test:
 - 2 a. A penetrometer is an instrument used to measure unconfined compressive strength in units of tons per square foot.
 - 2 b. Push the penetrometer ¼" deep into the sample and obtain a compressive strength reading.
 - 2 c. Several readings should be taken in different samples and all of the readings averaged.
 - (i) Type C soil will have an average reading of 0.5 tons per square foot or less.
 - (ii) Type B soil will have an average reading of greater than 0.5 but less than 1.5 tons per square foot.
 - (iii) Type A soil will have an average reading of 1.5 tons per square foot or greater.
3. Torvane® Shear Test:
 - 3 a. The Torvane is an instrument with blades on one end that are pushed into the soil sample. It is then twisted until the soil sample breaks loose at which point a reading is taken.
 - 3 b. As with the pocket penetrometer several readings should be taken.
 - 3 c. Throw out the high and low reading and average the rest.
 - 3 d. The readings are in tons per square foot.
 - 3 e. The tons per square foot by soil type is the same as those listed for the Pocket Penetrometer shown above.

6.0 Soil Classification

6.1 Type C Soil Classification:

- 6.1.1 Cohesive soils with an unconfined compressive strength of 0.5 tons per square foot or less.
- 6.1.2 Granular soils including gravel, sand, or loamy clay
- 6.1.3 Submerged soil, soil where water is freely seeping, or submerged rock that is not stable.
- 6.1.4 A sample thumb penetration test indicates that a thumb can easily penetrate the sample.
- 6.1.5 Some tabulated data sheets classify Type C soil as either C-60 or C-80.
- 6.1.6 C-60 soil is soft cohesive or moist granular soil that is not flowing or submerged.
- 6.1.7 C-60 soil can be cut with a near vertical sidewalls and will stand unsupported long enough to allow vertical shoring to be properly installed.

UNCONTROLLED IF PRINTED

6.1.8 Sample tests using a Pocket Penetrometer or Torvane indicating a compressive strength reading of 0.5 tons per square foot or less.

6.2 Type B Soil Classification:

6.2.1 Cohesive soils with an unconfined compressive strength greater than 0.5 but less than 1.5 tons per square foot.

6.2.2 Granular non-cohesive soils such as angular gravel (similar to crushed rock), silt, silt loam, sandy loam, and in some cases silty clay loam, sandy clay loam, or dry unstable rock.

6.2.3 Type A soil that is fissured or subject to vibration

6.2.4 A sample thumb penetration test indicates that a thumb can penetrate the sample with moderate effort, 1 inch indentation.

6.2.5 Sample tests using a Pocket Penetrometer or Torvane indicating a compressive strength greater than 0.5 but less than 1.5 tons per square foot.

6.3 Type A Soil Classification:

6.3.1 Cohesive soils with an unconfined compressive strength of 1.5 tons per square foot or greater.

6.3.2 Examples of Type A soil include soils with a high clay content such as:

1. Clay
2. Silty clay
3. Sandy clay
4. Clay loam,
5. In some cases silty clay loam and sandy clay loam.

6.3.3 A sample thumb penetration test indicates that a thumb will have only slight to no penetration.

6.3.4 Sample tests using a Pocket Penetrometer or Torvane Shearvane indicating a compressive strength of 1.5 tons per square foot or greater.

6.3.5 Soil cannot be classified as Type A if:

1. The soil is fissured, which means that it exhibits open cracks, such as tension cracks, in an exposed surface.
2. The soil is subject to vibration from heavy traffic, pile driving, or other effects.
3. The soil has been previously disturbed.
4. The soil has other factors, such as water saturation, that would require it to be classified as a less stable material.

7.0 Destabilizing Factors

7.1 The Competent Person must investigate the excavation and adjacent area for signs of destabilizing factors that will result in downgrading the initial soil classification.

7.2 Destabilizing factors include:

7.2.1 Vibrations from heavy traffic or from nearby construction activity

7.2.2 Fissures in the soil face

UNCONTROLLED IF PRINTED

7.2.3 Previously disturbed soil

7.2.4 Free-flowing water from surface or subsurface sources

7.2.5 Surcharge loading from equipment, material, or spoil material

7.2.6 Wind loading against telephone poles, trees, or structures.

8.0 Excavation / Soils Checklist

8.1 An Excavation / Soils Checklist is required for every excavation greater than 2 feet in depth if personnel will enter the excavation.

8.2 The Competent Person is required to evaluate and classify the soil prior to personnel entering the excavation.

8.3 For excavations where an Excavation / Soils Checklist is required, a separate Checklist must be completed for each day an excavation is left open and workers are entering the excavation.

8.4 The Ameren Illinois (AIC) Safety Department develops and maintains the Excavation/ Soils Checklist. Contact an AIC Safety Supervisor for access to the Checklist.

End of Instructions

Operator Qualification (OQ) Required?

NO

Appendices

NONE

Attachments

NONE

Compliance Requirements

NONE

Reference Documents

AIC Field Safety Manual, Section 34.2. Soil Classification. Available on the AIC Safety SharePoint site.

Document Rescission

EXCV 2.04 Excavation Safety: Soil Analysis and Classification, December 1, 2020

Revision Notes Location	Summary of Changes
Entire document	Minor spelling and grammatical errors identified and fixed. Reformatted to match the October 1, 2020 re-write format.

UNCONTROLLED IF PRINTED

1.0 Purpose

The purpose of this section is to define when and how Sloping Protective Systems apply to excavation safety.

2.0 Scope

This document addresses the following:

[3.0 Target Audience](#)

[4.0 General](#)

[5.0 Sloping Protective System](#)

[6.0 Typical Sections for Different Soil Configurations](#)

3.0 Target Audience

- Gas Engineering
- Gas Distribution Design Specialist
- Gas Tech Engineering (GTE)
- Gas Storage Engineering (GSE)
- Gas Field Personnel
- Gas Supervisors
- Gas Tech Services (GTS) Personnel
- Gas Tech Services (GTS) Supervisors
- Gas Storage Field Personnel
- Gas Storage Field Supervisors
- Gas Construction Services personnel
- Gas Construction Services Supervisors
- Gas Construction Inspectors
- Gas Quality Assurance Consultants

4.0 General

4.1 A protective system is required on all excavations 5 feet in depth or greater into which personnel will enter.

4.2 A protective system is also required for all excavations less than 5 feet in depth if the Competent Person determines there is an indication of potential cave-in risk to personnel entering the excavation.

4.3 The Competent Person shall select the appropriate configuration based on the results of soil classification and operating conditions in the area of the excavation.

4.4 The Competent Person shall inspect the excavation daily, prior to workers entering the excavation, for indications of distress that would adversely affect the stability of the excavation such as:

4.4.1 Cracks in vertical soil face

4.4.2 Surface cracks behind the excavation

4.4.3 Water seepage

4.4.4 An increase in highly saturated soil at lower level of excavation

4.4.5 Sloughing of soil from vertical faces.

5.0 Sloping Protective System

5.1 Sloping requires cutting the soil back on all sides of the excavation/trench to an angle at which the soil can stand without failure.

5.2 The angle at which the soil can stand can be affected by:

5.2.1 Surcharge loads such as spoil pile, equipment or material located adjacent to the excavation.

5.2.2 Weather conditions, especially rain.

5.2.3 The soil being previously disturbed, either by excavation or as fill material.

5.3 The maximum slope for each soil type is: (width horizontally to depth vertically)

Type C - least stable	1-1/2H:1V	(e.g. 9' horizontal to 6' vertical)
Type B - moderately stable	1H:1V	(e.g. 6' horizontal to 6' vertical)
Type A - stable	3/4H:1V	(e.g. 4' horizontal to 6' vertical)

5.4 The actual slope of the excavation sides shall be no steeper than the maximum allowable slope.

5.5 When there are signs of distress in the side wall, the actual slope shall be at least 1/2H:1V flatter than the maximum allowable slope.

5.6 In a layered soil situation where a more stable soil is beneath a less stable soil, the maximum slope for each soil type can be used for each layer of soil.

5.7 In a layered soil situation where a less stable soil is beneath a more stable soil, the maximum slope for less stable soil must be used for the entire depth of excavation.

6.0 Typical Sections for Different Soil Configurations

6.1 Typical Sections below are in accordance with OSHA 1926.652 Appendix B to Subpart P.

6.2 Simple Slope configurations for the Soil Types A, B, and C:

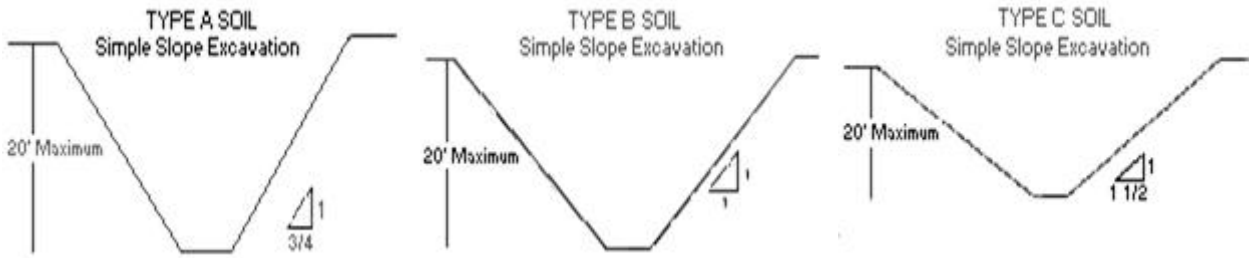

6.3 In Type A soil, if the excavation is 12 feet or less in depth and the excavation is open for 24 hours or less, the maximum slope can be 1/2H:1V.

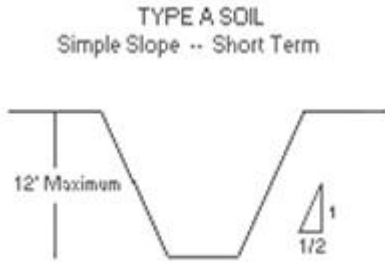

6.4 Slope configurations for various layered soil configurations:

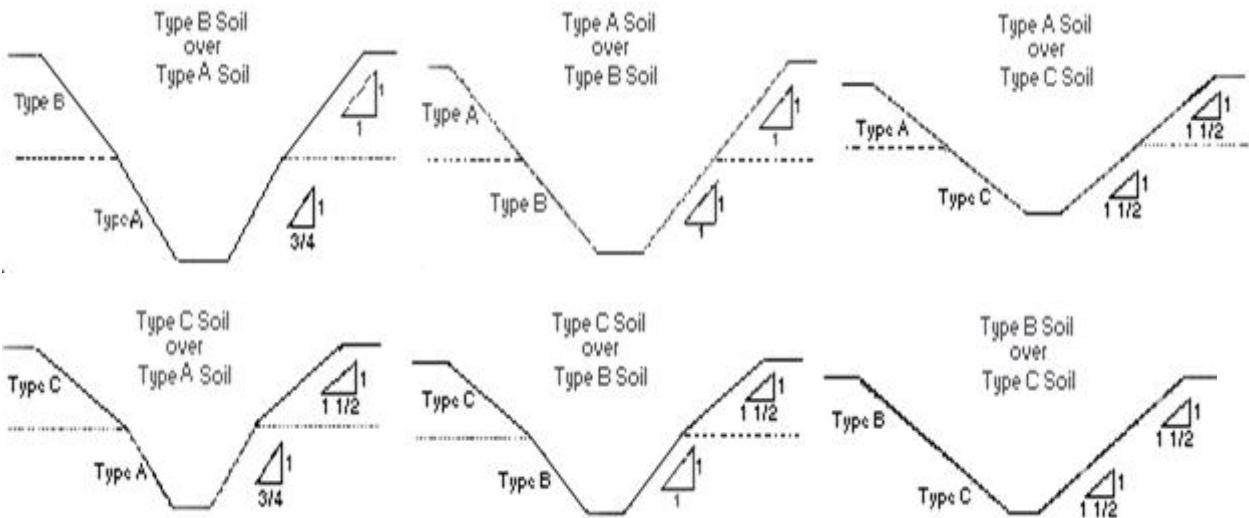

End of Instructions

Operator Qualification (OQ) Required?

NO

Appendices

NONE

Attachments

NONE.

Compliance Requirements

NONE

UNCONTROLLED IF PRINTED

Reference Documents

AIC Field Safety Manual, Section 34.0 Excavations. Available on the AIC Safety Share-Point site.

Document Rescission

EXCV 2.05 Excavation Safety: Sloping Protective System, January 1, 2014

Revision Notes Location	Summary of Changes
Entire document	Grammatical corrections and rewording Reformatted to match the October 1, 2020 re-write format.
Subsection 4.4	Added – prior to workers enter the excavation

1.0 Purpose

This section outlines the procedures, requirements, and limitations by which sloping and benching systems can be utilized when excavating.

2.0 Scope

This document addresses the following:

[3.0 Target Audience](#)

[4.0 General](#)

[5.0 Sloping & Benching Protective System](#)

[6.0 Excavation in Type A Soil](#)

[7.0 Excavation in Type B Soil](#)

3.0 Target Audience

- Gas Engineering
- Gas Distribution Design Specialist
- Field Engineering Representatives
- Gas Field Personnel
- Gas Supervisors
- Gas Tech Services (GTS) Personnel
- Gas Tech Services (GTS) Supervisors
- Gas Storage Field Personnel
- Gas Storage Field Supervisors
- Gas Construction Services Personnel
- Gas Construction Services Supervisors

4.0 General

- 4.1 A protective system is required on all excavations 5 feet in depth or greater into which personnel will enter.
- 4.2 A protective system is also required for excavations less than 5 feet in depth if the Competent Person determines there is an indication of potential cave-in risk to personnel entering the excavation.
- 4.3 The Competent Person shall select the appropriate configuration based on the results of soil classification and operating conditions in the area of the excavation.
- 4.4 The Competent Person shall inspect the excavation daily, prior to workers entering the excavation, for indications of distress that would adversely affect the stability of the excavation such as:

- 4.4.1 Cracks in vertical soil face
- 4.4.2 Surface cracks behind the excavation
- 4.4.3 Water seepage
- 4.4.4 An increase in highly saturated soil at lower level of excavation
- 4.4.5 Sloughing of soil from vertical faces

5.0 Sloping & Benching Protective System

- 5.1 Sloping and benching is a combination of vertical benches cut into the slope at lower levels in the excavation and the upper portion sloped at the appropriate maximum angle for the type of soil.
- 5.2 The maximum applicable excavation depth is 20 feet.
- 5.3 The maximum angle of slope for the various soil types is shown in the Sloping Protective System section.
- 5.4 Sloping & Benching is only allowed in Type A and Type B soils, not in Type C soils.
- 5.5 A single bench is allowed in these configurations for Type A and Type B soils:
 - 5.5.1 In Type A soil, a 4 feet vertical face at the bottom with a 3 feet wide bench is allowed
 - 5.5.2 In Type B soil, a 4 feet vertical face at the bottom with a 4 feet wide bench is allowed.
- 5.6 The vertical height at the bottom of the trench must not exceed 4 feet for the first bench.
- 5.7 In Type A soil, subsequent benches may be up to 5 feet vertically up to a total excavation depth of 20 feet.
- 5.8 In Type B soil, subsequent benches may be up to 4 feet vertically up to a total excavation depth of 20 feet.
- 5.9 In Multiple Benching configurations the width of the first bench should be calculated as follows:
 - 5.9.1 Type A soil:
 1. The maximum allowable slope is 3/4H:1V.
 2. The height of the lowest bench (H1) cannot exceed 4 feet. The height of the second bench (H2) cannot exceed 5 feet.
 3. The minimum bench width for Type A soil is calculated as $(H1+H2) \times 0.75$.
 4. For example, where $H1 = 4 \text{ FT}$ and $H2 = 5 \text{ FT}$, the minimum bench width is 6.75 FT.
 - 5.9.2 Type B soil:
 1. The maximum allowable slope is 1H:1V
 2. The height of the lowest bench (H1) cannot exceed 4 feet. The height of the second bench (H2) cannot exceed 4 feet.
 3. The minimum bench width for Type B soil is calculated as $(H1+H2) \times 1.0$.
 4. For example, where $H1 = 4 \text{ FT}$ and $H2 = 4 \text{ FT}$, the minimum bench width is 8 FT.

5.9.3 Additional benches widths should be calculated based on the height of the bench times the applicable slope for the soil type, not to exceed the maximum total excavation height shown in diagrams below.

6.0 Excavation in Type A Soil

6.1 Typical Sections are in accordance with OSHA 1926.652 Appendix B to Subpart P.

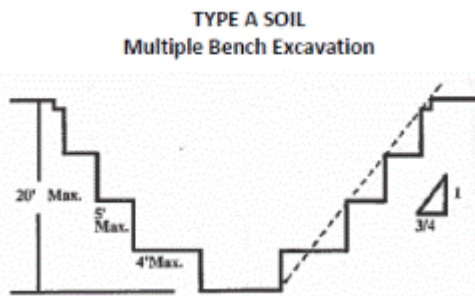
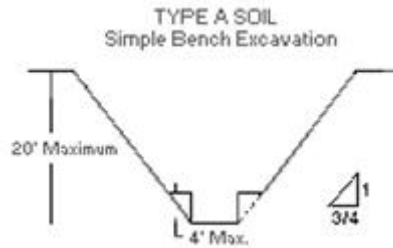

6.2 Excavations 8 feet or less may have a maximum 3-1/2 feet unsupported vertical lower portion with the remaining soil sloped at a maximum of 3/4 H:1V.

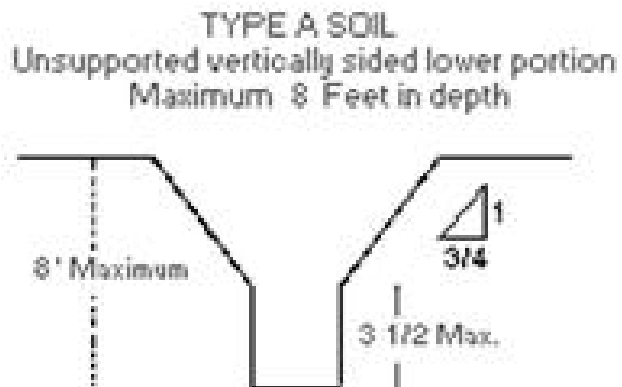

6.3 Excavations between 8 feet and 12 feet with 3-1/2 feet unsupported vertical lower portion must have the remaining soil sloped at a maximum of 1H:1V.

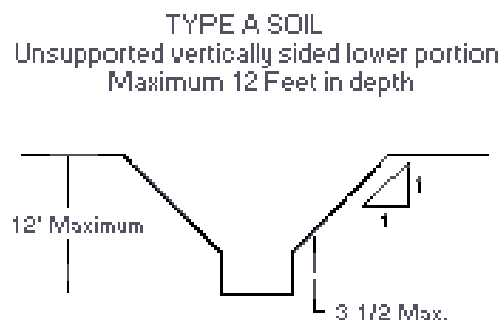

7.0 Excavation in Type B Soil

7.1 Typical Sections are in accordance with OSHA 1926.652 Appendix B to Subpart P.

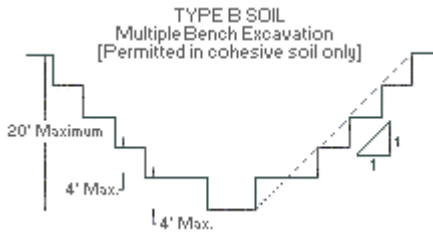
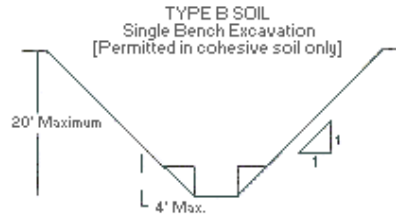

End of Instructions

Operator Qualification (OQ) Required?

NO

Appendices

NONE

Attachments

NONE

Compliance Requirements

NONE

Reference Documents

AIC Field Safety Manual, Section 34.6 Shoring and Shielding. Available on the AIC Safety SharePoint site.

Document Rescission

EXCV 2.06 Excavation Safety: Sloping and Benching Protective System, January 1, 2014

Revision Notes Location	Summary of Changes
Whole document	Minor grammar and tense issues fixed. Reformatted to match the October 1, 2020 re-write format
Subsection 4.4	Added – prior to workers entering the excavation

1.0 Purpose

This section outlines the requirements for the installation of a Aluminum Hydraulic Shoring Protective System.

2.0 Scope

This document addresses the following:

[3.0 Target Audience](#)

[4.0 General](#)

[5.0 Hydraulic Shoring](#)

[6.0 Typical Sections for Hydraulic Shoring](#)

3.0 Target Audience

- Gas Engineering
- Gas Distribution Design Specialist
- Gas Tech Engineering (GTE)
- Gas Storage Engineering (GSE)
- Gas Field Personnel
- Gas Supervisors
- Gas Tech Services (GTS) Personnel
- Gas Tech Services (GTS) Supervisors
- Gas Storage Field Personnel
- Gas Storage Field Supervisors
- Gas Construction Services Personnel
- Gas Construction Services Supervisors
- Gas Construction Inspectors
- Gas Quality Assurance Consultants

4.0 General

4.1 Aluminum hydraulic shoring can be used in excavations of 20 feet in depth or less to protect workers from a cave-in.

4.2 Aluminum hydraulic shoring manufacturer's tabulated data table must be kept at the job site during the work.

4.3 A Competent Person is required to perform soil analysis and soil classification prior to installation of an aluminum hydraulic shoring system.

5.0 Hydraulic Shoring

- 5.1 When planning to use aluminum hydraulic shoring, plan the digging so that sides of excavation will support the rails.
- 5.2 The Manufacturer's tabulated data table for Speed Shore with sizes and allowable depths has a Registered Professional Engineer's stamp but there are no specific serial numbers listed.
- 5.3 No variation from the manufacturer's tabulated data table is allowed without written approval from the manufacturer or a registered professional engineer.
- 5.4 Hydraulic shoring should be checked during each work period for leaking hoses and/or cylinders, broken connections, cracked nipples, bent bases, and any other damaged or defective parts.
- 5.5 Hydraulic shoring members must be released slowly to note any movement in the adjacent ground or for failure of adjacent members.
- 5.6 Hydraulic shoring shall be installed from top down and removed from bottom up. At no time may personnel enter the excavation to install the shoring components necessary to protect from cave-in.
- 5.7 The centerline of the top cylinder shall be between 12 inches and 24 inches below the top of the excavation.
- 5.8 Two feet of the trench wall may be exposed beneath the bottom of the plywood sheeting, if used.
- 5.9 In excavations 6 feet or less in depth, one hydraulic cylinder is required in each vertical plane. The cylinder must be no more than 4 feet from the bottom of the excavation and no more than 2 feet below the top.
- 5.10 In excavations 6 feet to 10 feet in depth, there shall be a minimum of two hydraulic cylinders in each vertical plane. The horizontal spacing shall be that shown on the Tabulated Data Sheet for the shoring system being used.
- 5.11 The maximum vertical distance between horizontal rows of cylinders is 4 feet.
- 5.12 For excavations less than or equal to 12 feet in depth, there shall be a minimum of 3 consecutive cylinders in a horizontal row, at the horizontal spacing shown on the tabulated data sheet.
- 5.13 For excavations over 10 feet in depth, a minimum of 4 consecutive cylinders in a horizontal row shall be placed at the horizontal spacing shown on the tabulated data sheet.
- 5.14 For excavations that are not long enough for 3 or 4 cylinders, the cylinders shall be placed at the required horizontal spacing with a minimum of 2 cylinders, with one cylinder within 2 feet of each end of the excavation.
- 5.15 The ends of trenches must be protected from cave-in by sloping, benching, or trench-end shielding.
- 5.16 No vertical or lateral loads shall be applied to the shoring cylinders.
- 5.17 Sheeting is only used to prevent local raveling or sloughing of the trench face between the vertical shores.
- 5.18 Sheeting shall be either 3/4 inch thick, 14-ply, arctic white birch (Finn Form) plywood or 1-1/8 inch thick CDX plywood or approved equal.
- 5.19 Sheeting must extend to the top of the excavation and to within 2 feet of the bottom. If shoring/sheeting is used on a lower vertical section of a slope, the sheeting must ex-

tend a minimum of 18 inches above the bottom of the slope, in order to protect personnel from material rolling into the trench.

5.20 Excavations deeper than 4 feet shall have a means for workers to enter and exit which meets the requirements of **EXCV 2.3**.

5.20.1 The means to enter or exit shall be located no more than 25 feet laterally from any worker.

5.20.2 A ladder must be provided in each location between shoring cylinders where personnel are working.

5.20.3 Ladder must extend 3 feet above the top of the landing and be secured to prevent movement.

5.21 Any walkways crossing the excavation must meet OSHA walkway standards. Personnel must be protected from falls into excavations that are 6 feet or deeper.

5.22 When it can be reasonably expected that a hazardous environment could exist, the environment must be monitored for oxygen content and combustible or toxic gases with a calibrated gas detector.

6.0 Typical Sections for Hydraulic Shoring

6.1 See images below:

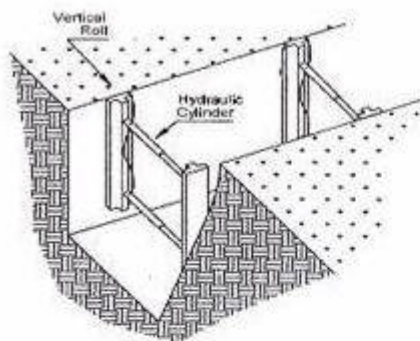

Vertical Aluminum Hydraulic Shoring
(Spot Bracing)

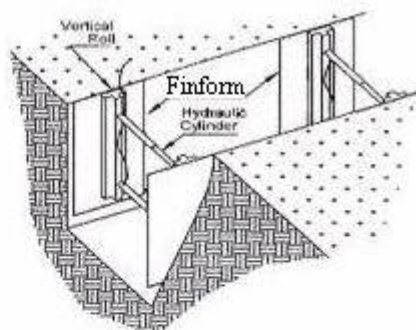

Vertical Aluminum Hydraulic Shoring
(With Finform)

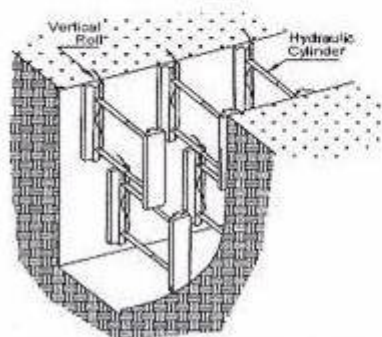

Vertical Aluminum Hydraulic Shoring
(Stacked)

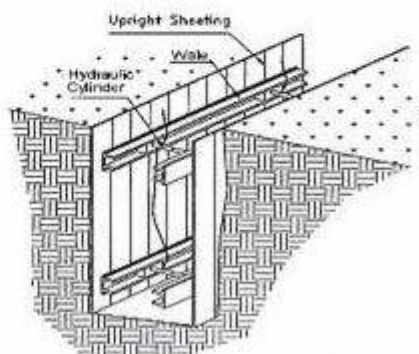

Aluminum Hydraulic Shoring Water System
(Typical)

End of Instructions

Operator Qualification (OQ) Required?

UNCONTROLLED IF PRINTED

NO

Appendices

NONE

Attachments

NONE

Compliance Requirements

NONE

Reference Documents

AIC Field Safety Manual, Section 34.6 Shoring and Shielding. Available on the AIC Safety SharePoint site.

Document Rescission

EXCV 2.07 Excavation Safety: Aluminum Hydraulic Shoring Protective System, October 1, 2021

Revision Notes Location	Summary of Changes
Entire document	Minor grammar corrections but content is the same. Reformatted to match the October 1, 2020 re-write format
Subsection 4.3	Added – prior to the installation of an aluminum hydraulic shoring system.

1.0 Purpose

This document provides the requirements for the installation of a Trench Box system.

2.0 Scope

This document addresses the following:

[3.0 Target Audience](#)

[4.0 General](#)

[5.0 Trench Box Protective System](#)

[6.0 Typical Trench Box](#)

[7.0 Typical Sections for Trench Box Installation](#)

3.0 Target Audience

- Gas Engineering
- Gas Distribution Design Specialist
- Gas Tech Engineering (GTE)
- Gas Storage Engineering (GSE)
- Gas Field Personnel
- Gas Supervisors
- Gas Tech Services (GTS) Personnel
- Gas Tech Services (GTS) Supervisors
- Gas Storage Field Personnel
- Gas Storage Field Supervisors
- Gas Construction Services Personnel
- Gas Construction Services Supervisors
- Gas Construction Inspectors
- Gas Quality Assurance Consultants

4.0 General

4.1 While shoring is designed to shore up or otherwise support the trench face, Trench shields (boxes) are intended primarily to protect gas field personnel from cave-ins and similar incidents.

4.2 Trench boxes can be used in excavations 20 feet in depth or less.

4.3 If space between the trench boxes and the excavation sides is greater than 6 inches, backfilling to 1/3 the height of the box is required to prevent lateral movement of the box.

- 4.4 A Competent Person is required to perform soil analysis and soil classification prior to installation of the trench box.
- 4.5 The manufacturer's tabulated data for a trench box must be kept at the job site during the work.

5.0 Trench Box Protective System

- 5.1 Trench boxes are generally used in open areas, but they also may be used in combination with sloping and benching.
- 5.2 Trench box shall not be subject to loads exceeding those specified in the manufacturer's tabulated data sheets.
- 5.3 Sloping above the trench box must be no greater than the maximum allowable slope for the soil type of the excavation.
- 5.4 The box shall extend at least 18 inches above the surrounding area to protect personnel from falling material if there is sloping toward the excavation. This can be accomplished by providing a benched area next to the box.
- 5.5 The ends of the box must be either enclosed with aluminum slats, Finn Form plywood or must be sloped at the appropriate allowable slope.
- 5.6 Trenches 4 feet and deeper must have a means of exit and entry by either a ramp or ladder in the side of the trench.
- 5.7 Ladder should be placed inside the trench box and must extend 3 feet above the landing and must be secured to prevent movement.
- 5.8 In longer excavations, an exit is required within 25 feet of each worker.
- 5.9 The box may be set 2 feet above the bottom of the trench, but the box must be designed for the full depth of the trench and there is no raveling of the soil below the box.
- 5.10 No variation from the manufacturer's tabulated data sheet is allowed without the written approval of the manufacturer or a registered professional engineer.
- 5.11 Workers shall not be allowed to be inside the trench box while it is being moved.
- 5.12 Workers shall not be allowed to be outside of the protective area of the trench box when working in a trench box protected excavation.
- 5.13 All components and structural members of the trench box shall be inspected daily to ensure they are properly connected and have not sustained damage to their structural integrity is in question.
- 5.14 Any walkways crossing the excavation must meet OSHA walkway standards. Personnel must be protected from falls into excavation that are 6 feet or deeper.
- 5.15 When it can be reasonably expected that a hazardous environment could exist, the environment must be monitored for oxygen content and combustible or toxic gases with a calibrated gas detector.

6.0 Typical Trench Box

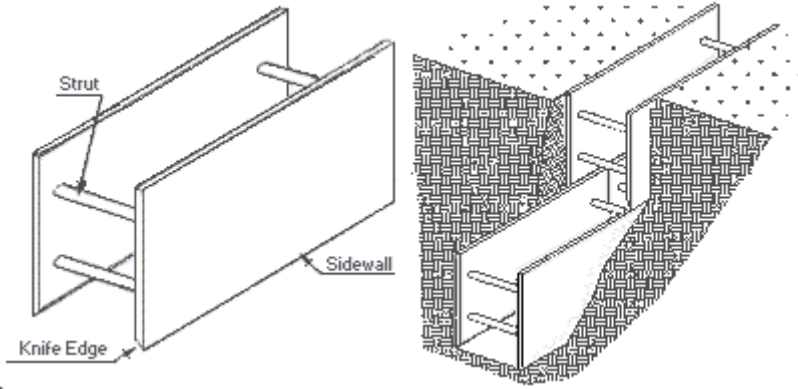

7.0 Typical Section for Trench Box Installation

7.1 A. Typical sections are in accordance with OSHA 1926.652 Appendix B to Subpart P.

SLOPE AND SHIELD CONFIGURATIONS

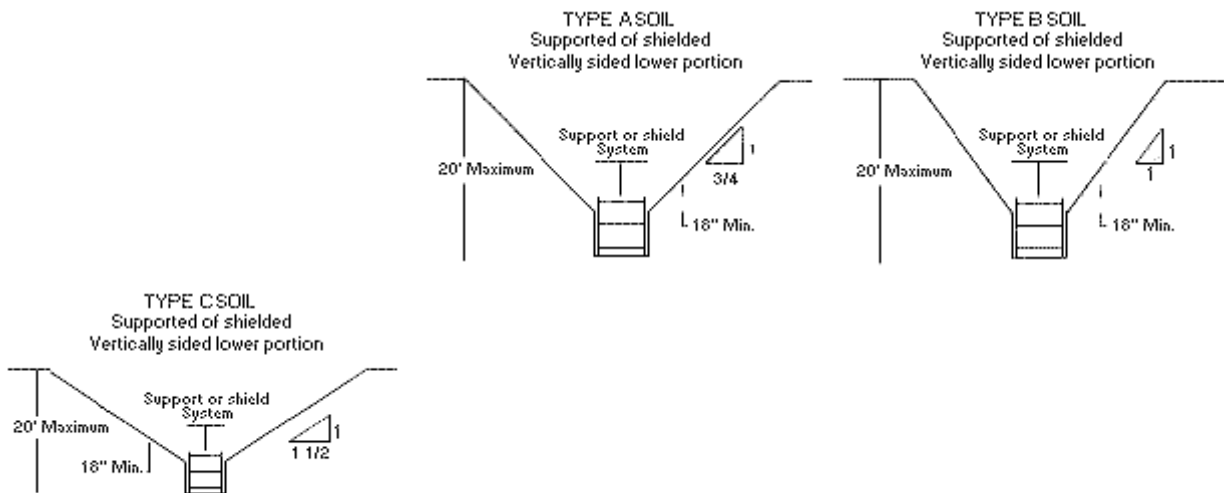

End of Instructions

Operator Qualification (OQ) Required?

NO

Appendices

NONE

Attachments

NONE

Compliance Requirements

NONE

Reference Documents

UNCONTROLLED IF PRINTED

AIC Field Safety Manual, Section 34.6 Shoring and Shielding. Available on the AIC Safety SharePoint site.

Document Rescission

EXCV 2.08 Excavation Safety: Trench Box Protective System, October 1, 2021

Revision Notes Location	Summary of Changes
Entire Document	Small grammar correction. No major changes to content. Reformatted to match the October 1, 2020 re-write format
Subsection 4.4	Added – prior to installation of the trench box.

1.0 Purpose

This document provides the procedures and requirements for safely working in an excavation that is or could be considered a hazardous environment.

2.0 Scope

This document addresses the following:

[3.0 Target Audience](#)

[4.0 General](#)

[5.0 Prior to Beginning Work](#)

[6.0 Entering Excavation](#)

[7.0 Hazardous Concentration of Natural Gas – Level 1 PPE Requirement](#)

[8.0 Hazardous Concentration of Natural Gas – Level 2 PPE Requirement](#)

3.0 Target Audience

- Gas Engineering
- Gas Distribution Design Specialist
- Gas Tech Engineering (GTE)
- Gas Storage Engineering (GSE)
- Gas Field Personnel
- Gas Supervisors
- Gas Tech Services (GTS) Personnel
- Gas Tech Services (GTS) Supervisors
- Gas Storage Field Personnel
- Gas Storage Field Supervisors
- Gas Construction Services Personnel
- Gas Construction Services Supervisors
- Gas Construction Inspectors
- Gas Quality Assurance Consultants

4.0 General

4.1 Gas field personnel shall not enter excavations that contain a hazardous environment until appropriate alternative work options have been explored and then only while utilizing the appropriate personal protective equipment (PPE).

- 4.2 A hazardous environment is present when gas concentrations are measured with a gas detector at 30% LEL or greater, when the oxygen level is measured at 19.5% or less, or when toxic gases (carbon monoxide, hydrogen sulfide, etc.) are present.
- 4.3 Gas field personnel will follow the procedures specified in [WIGE 2.1](#) Hazardous Environment.

5.0 Prior to Beginning Work

- 5.1 Gas field personnel shall explore and utilize all available options to eliminate a hazardous concentration of natural gas in an excavation before entering the excavation. This would include:
- 5.1.1 Utilizing valves.
 - 5.1.2 Squeezing plastic pipe.
 - 5.1.3 Installing control fittings.
 - 5.1.4 Using ventilating equipment
- 5.2 If the oxygen level of an excavation is less than 19.5%, ventilating equipment should be used to provide additional oxygen to the excavation and reduce gas concentrations.
- 5.2.1 Gas field personnel working in oxygen deficient excavations shall be provided with breathing equipment and emergency rescue equipment (full-body harness, life-line, and means to positively extract a worker).
 - 5.2.2 If the oxygen level cannot be raised above 19.5%, additional standby personnel, outfitted with the same level of protective equipment, shall be present to provide emergency assistance as needed.

6.0 Entering Excavation

- 6.1 The environment of the excavation shall be tested with a gas detection instrument to determine the amount of combustible gas present and the oxygen level.
- 6.2 If there is a possible source or indication of toxic gasses such as carbon monoxide or hydrogen sulfide, the environment should be tested for the specific gas(s) prior to allowing anyone to enter.
- 6.3 The environment must be checked and monitored in the immediate area where the work is to be performed.
- 6.4 Gas field personnel shall continuously monitor the environment in the excavation as long as gas field personnel are working in the excavation.
- 6.5 Gas field personnel wearing their standard work clothing may work in an excavation that has a gas concentration less than 30% LEL and an oxygen level of at least 19.5%

Gas personnel shall immediately vacate the excavation and suit-up in the proper PPE if:

Gas concentration rises to 30% LEL or higher, OR

Oxygen level drops below 19.5%.

- 6.6 If gas field personnel enter an excavation with a hazardous concentration of natural gas, they shall be positioned in the excavation in such a manner that the flow of natural gas is not directed toward them.
- 6.7 A properly sized dry chemical fire extinguisher shall be dry chemical (A, B, C) fire extinguisher shall be at the location of the work. See [WIGE 2.1](#) Subsection 4.3.2.

7.0 Hazardous Concentration of Natural Gas – Level 1 PPE Requirement

- 7.1 The following identifies a hazardous concentration of natural gas in an excavation which requires gas field personnel to wear Level 1 PPE as specified in [WIGE 2.2](#) Personal Protective Equipment, (no supplied air breathing apparatus).
- 7.1.1 Combustible gas-in-air 30% and 60% of the Lower Explosive Limit (3% natural gas-in-air) and oxygen level remains above 19.5%.

8.0 Hazardous Concentration of Natural Gas – Level 2 PPE Requirement

- 8.1 Environment with gas-in-air concentration in excess of 60% of the LEL (3% natural gas-in-air) or more follow the requirements in [WIGE 2.2](#) Personal Protective Equipment.

End of Instructions

Operator Qualification (OQ) Required?

YES

0301: Manually Opening and Closing Valves

1141: Squeeze-Off Plastic Pipe

1151: Squeeze-Off Steel Pipe

A003: Emergency Response

Appendices

NONE

Attachments

NONE

Compliance Requirements

NONE

Reference Documents

[WIGE 2.1 Working in Gaseous Environment: Hazardous Environment](#)

[WIGE 2.2 Working in Gaseous Environment: Personal Protective Equipment](#)

Document Rescission

EXCV 2.09 Excavation Safety: Working in Hazardous Environment, October 1, 2021

Revision Notes Location	Summary of Changes
Whole document	Changed multiple spelling, grammar, and wording issues. Reformatted to match the October 1, 2020 re-write format
Subsection 6.5	Revised - Gas field personnel wearing their standard work clothing may work in an excavation that has a gas concentration less than 30% LEL and an oxygen level of at least 19.5%.
Subsection 6.5 - NOTE	New - Gas personnel shall immediately vacate the excavation and suit-up in the proper PPE if: Gas concentration rises to 30% LEL or higher, OR Oxygen level drops below 19.5%.

EXCAVATION SAFETY

EXCV 4 Forms and Reference Materials

Click on the links below to open the documents.

References

[Speed Shore Tabulated Data – Vertical Shores](#)

[Speed Shore Tabulated Data – Shoring Shields](#)

[Speed Shore's Aluminum Panel Shields Tabulated Data](#)

[Speed Shore's MAPS-B Tabulated Data](#)

End of Section.

Document Rescission

EXCV 4 Excavation Safety: Forms and Reference Materials, January 1, 2018

Revision Notes

Location of Changes	Summary of Changes
Whole document	Reformatted to match the October 1, 2020 re-write format

Acronyms used in the Industry and O&M:

- AIC** - Ameren Illinois Company
- AISI** - American Iron & Steel Institute
- AMI** - Advanced Metering Infrastructure
- AMR** - Automatic Meter Reading
- ANSI** - American National Standards Institute.
- AOC** - Abnormal Operating Condition
- API** - American Petroleum Institute
- ARO** - Abrasive Resistant Overcoat
- ASME** - American Society of Mechanical Engineers
- ASTM** - American Society for Testing & Materials
- ASV** – Automatic Shut-off Valve
- AWS** - American Welding Society
- BTU** - British Thermal Unit
- CATV** - Cable television
- CF** - Cubic feet
- CFH** - Cubic feet per hour
- CGI** - Combustible Gas Indicator
- CI** - Cast Iron
- CO** - Carbon Monoxide
- CP** - Cathodic Protection
- CTS** - Copper tubing size
- ECA** - Engineering Critical Assessment
- EFV** - Excess Flow Valve
- FBE** - Fusion Bonded Epoxy
- FE** - Flanged end
- FF** - Flat faced flange
- FI** - Flame Ionization Unit
- FIP** - Female iron pipe
- FPS**- Feet per second
- FPT**- Female pipe thread
- GMAW** - Gas metal arc welding

GSE - Gas Storage Engineering

GTE - Gas Tech Engineering

GTS - Gas Tech Services

HCA - High Consequence Area

ICC - Illinois Commerce Commission

ID - Inside diameter

IDNR - Illinois Department of Natural Resources

IEMA - Illinois Emergency Management Agency

IM - Integrity Management

In. W.C. - Inches water column

IPS - Iron pipe size

J.U.L.I.E. - Joint Utility Locating Information for Excavators, also known as the Illinois One Call System.

LEL - Lower Explosive Limit

LOTO - Acronym for lock out/tag out

MAOP - Maximum Allowable Operating Pressure

MCA - Moderate Consequence Area

MCF - 1000 cubic feet.

MCFH - 1,000 cubic feet per hour

MEP - Maximum Emergency Pressure

MMBTU - Million BTUs or approximately 1 MCF.

MMCF - Million cubic feet

MPT - Male pipe thread

mA - Milliampere

MTR - Mill Test Report

mV - Millivolt

NACE - National Association of Corrosion Engineers

NDT - Nondestructive Testing

NFPA - National Fire Protection Association

NPMS - National Pipeline Mapping System

NPT - National pipe thread

NRC - National Response Center

NTSB - National Transportation Safety Board

O&M - Operating and Maintenance Plan

OAS - Outage Analysis System

OD - Outside diameter

UNCONTROLLED IF PRINTED

OPP - Over Pressure Protection

OSHA - Occupational Safety & Health Administration

PE - Polyethylene Pipe

PHMSA - Pipeline and Hazardous Materials Safety Administration

PIC - Potential Impact Circle

PIR - Potential Impact Radius

PPE - Personal Protective Equipment

PPI - Plastic Pipe Institute

PPM - Parts per million

PSI - Internal pressure measurement in pounds per square inch

PSIA - Pounds per Square Inch Absolute

PSID - Pounds per square inch differential

PSIG - Pounds per Square Inch Gauge

P/S - Pipe-to-Soil

RCV – Remote Controlled Valve

RF - Raised face flange

RMV – Rupture Mitigation Valve

ROW - Right-of-Way

SCADA - Supervisory Control and Data Acquisition system

SCFH - Standard cubic feet per hour

SDR - Standard dimension ratio (a measure of pipe diameter to wall thickness)

SFR - Single Family Residence

SMAW - Shielded Metal Arc Welding

SMYS - Specified Minimum Yield Strength

UEL - Upper Explosive Limit

UNC ## - Uniform National Coarse (# of threads per inch)

W.C. - Water column

WE - Weld end

WOG - Water-oil-gas (a term used in regard to pressure ratings).

WOP - Working operating pressure

WPQR - Welding Procedure Qualification Report

WPS - Welding Procedure Specification

Abandoned Facility - A pipeline facility that is physically separated from its source of gas and is no longer maintained.

Abnormal Operating Condition (AOC) - A condition identified by Ameren that may indicate a malfunction of a component or a deviation from normal operations that may indicate an operating condition that could exceed design limits or result in hazard(s) to persons, property, or to the environment.

Absolute Pressure (PSIA) - One of two often-used pressure measurements. Absolute pressure is obtained by adding the atmospheric pressure to the gauge pressure.

Active Corrosion - Continuing corrosion that unless controlled, could result in a condition that is detrimental to public safety.

Air Intake - An opening (duct, pipe, vent) through which air is mechanically drawn into a structure.

Ameren Critical Gas Facilities - The Company has identified the gas facilities that are considered critical utilizing the criteria listed in the Office of Pipeline Safety Security Guidance document issued on September 5, 2002. The list of Critical Gas Facilities is confidential and, therefore, is maintained separately from this document.

Anode - The corroding area of a corrosion cell, or a device used to generate cathodic protection current.

Appurtenance - Any equipment or instrument directly connected to a main or service line.

Atmospheric Corrosion - Steady and gradual deterioration (actual loss of metal that results in pitting or wall loss) of the exposed surface of a metal by oxidation or reaction with elements of the atmosphere.

Atmospheric Pressure - The pressure of the weight of air and water vapor on the surface of the earth. (Approximately 14.4 pounds per square inch in the Midwest.)

Automatic Shut-off Valve - ASV has an electric or gas powered actuators to close a designated valve automatically based on data piped or wired to the actuator from pipeline taps and sensors.

Auxiliary Equipment - Means an integral device attached directly or remotely to a gas meter. The function of auxiliary equipment is to adjust gas meter usage measurements to account for changes in gas temperature or pressure (for example, correctors).

Backfill - Earth, material or low strength flow-able material that has been replaced in an excavation or trench after pipe or other device has been installed.

Bar Hole Testing - A test where a probe bar is used to make a hole in the ground to test for the presence of gas.

Base Pressure - The pressure used to define a standard cubic foot of gas. Base pressure is normally 14.73 psia which is also 0.25 psig or 7 inches water column.

Base Temperature - The temperature used to define a standard cubic foot of gas. Base temperature is normally 520° R which is also 60°F.

Bedding - Soil free of rocks, soil clumps and debris that is spread in a trench before a pipe is installed.

Bell Hole - An excavation to allow adequate work room for workmen to conduct a required operation--i.e. install service tees, make a tie-in, etc.

Benching - A worker protection method that involves cutting the sides of an excavation to form a series of steps. This technique helps workers by spreading the downward pressure on the excavation over a wider area.

Boring - Installing pipe by drilling a route below grade under or over a buried obstacle.

Branched Service Line - A gas service line that begins at the existing service line or is installed concurrently with the primary service line but serves a separate residence.

- Adjoining or adjacent residential or small commercial customer. Or
- Multiple residential or small commercial customers served through a meter header or manifold.

Bridging - Providing extra support for pipe in areas of abnormal stress or loading.

British Thermal Unit (BTU) - Energy measurement. The amount of heat required to raise 1 pound of water 1 degree F at standard conditions. The average BTU content of natural gas is 1,000 BTUs per cubic foot.

Building - Any structure which is regularly or periodically occupied by people.

Butt Fusion - A method of joining pipe by fusing two pipe sections directly end-to-end. The pipe ends are melted together and held until cooled.

Butt Weld - The joining of 2 abutting parts lying in approximately the same plane. Generally, the completed circumferential weld joining 2 sections of pipe.

Cadweld - A trade-name for the process of thermite welding used to attach wires to steel pipe.

Calibrating Gauge - Instruments that utilities use in the field or the meter shop to test the accuracy of auxiliary and tertiary equipment, transmitters, and other equipment associated with correcting a meter's output. Synonymous with Portable Standard

Capable of Being Locked Out - An energy isolating device is capable of being locked out if it has a hasp or other means of attachment to which or through which a lock can be affixed or it has a built in locking device. Other energy isolating devices are capable of being locked out if lockout can be achieved without the need to be dismantled, rebuilt, replaced, or permanently altering its energy control capability.

Carbon Dioxide (CO₂) - An inert gas formed by the combustion of organic materials often used for purging.

Carbon Monoxide (CO) - A toxic gas formed when a fuel such as natural gas is burned incompletely.

Carrier Pipe - A pipe that carries natural gas which is inserted into a larger casing.

Casing - A length of pipe used for encasing a smaller diameter carrier pipe for installation in a well or under a road, etc.

Cast Iron (CI) - An iron alloy which contains a high carbon content that is cast in molds. It is more brittle than steel.

Cathode - The protected area of a corrosion cell.

Cathodic Protection (CP) - The prevention of corrosion by the use of sacrificial anodes or rectifiers which provide a small electrical charge to concentrate corrosion on a controlled anode.

Class Location - An area that extends 220 yards on either side of the centerline of any continuous 1 mile length of a pipeline. The Class location ends 220 yards from the last feature that defines the class location.

- Class 1 Location - any class location unit that has 10 or less buildings intended for human occupancy.
- Class 2 Location - any class location unit that has more than 10 but less than 46 buildings intended for human occupancy.

UNCONTROLLED IF PRINTED

- **Class 3 Location** - any class location unit that has 46 or more buildings intended for human occupancy, or an area where the pipeline lies within 100 yards of a building or a small well defined outside area that is occupied by 20 or more persons during normal use, such as a playground, recreation area, outdoor theater, or any other place of public assembly.
- **Class 4 Location** - any class location where buildings of four or more stories above ground are prevalent.

Clean Construction or Demolition Debris (CCDD) - Means uncontaminated broken concrete without protruding metal bars, bricks, rock, stone, reclaimed or other asphalt pavement, or soil generated from construction or demolition activities. Does not include uncontaminated soil generated during construction, remodeling, repair, and demolition of utilities, structures, and roads provided the uncontaminated soil is not commingled with any clean construction or demolition debris or other waste.

ClickMobile - Mobile Workforce Management system used to document Gas Compliance activities electronically.

ClickSchedule - Mobile Workforce Management system used to schedule and dispatch Gas Compliance activities to field technicians

Coating - A corrosion preventing material which breaks up the corrosion cell by preventing electrolyte from contacting the pipe. (i.e. FBE, Hot or Cold Applied Tapes, Moisture Cured Wraps)

CO Detector - An instrument used to detect the presence and level of carbon monoxide.

Cohesive soil - Soil with a high clay content, which does not crumble.

Combination Leak and Strength Test - A pressure test that verifies gas pipeline or gas facility has no hazardous leak and qualifies the pipeline/facility's maximum allowable operating pressure (MAOP).

Combustible Gas Indicator (CGI) - An instrument used to measure the percentage of gas-in-air.

Commercial Service - A single or branch service line serving a gas meter or gas meters that are qualified to be billed under Ameren Illinois' Non - Residential Gas Delivery Service GDS - 2 thru GDS - 7 rates as specified in the Ameren Illinois Gas Service Tariff- Schedule 2. A small commercial customer is one that uses less than 5,000 therms annually as defined in the Public Utilities Act 220 ILCS 5.

Compaction - Pressing the soil into place during back filling operations.

Company - Refers to Ameren Illinois Company (AIC) or its designated agent. The Company may act through an inspector or another authorized representative.

Competent Person - A person that through training and qualification has the knowledge, skills, and ability to analyze ground conditions and take adequate precautions to protect workers from the hazards of cave-ins.

Conduit - A pipe or tube through which electric wires, cables or smaller pipe pass.

Confirmed Discovery - means when it can be reasonably determined, based on information available to the operator at the time a reportable event has occurred, based on a preliminary on-scene evaluation.

Contractor - Individual(s) retained by Ameren, who, on behalf of Ameren, perform(s) one or more covered tasks on Ameren pipeline facilities.

Controller - A qualified individual who remotely monitors and controls the safety-related operations of a pipeline facility via a SCADA system from a control room, and who has operational authority and accountability for the remote operational functions of the pipeline facility.

Control Line - A pressure sensing line connecting a regulator, relief valve or valve actuator to the segment of line for which controlled pressure is desired.

Control Room - An operations center staffed by personnel charged with the responsibility for remotely monitoring and controlling a pipeline facility.

Control Valve - A remote-set or locally-set device that is typically bi-functional and used to govern gas flow while self-monitoring downstream gas pressure as an override precaution.

Corrosion - The tendency of metal to return to its natural state. Steel returns to iron ore in the form of rust.

Corrosion Records - Sources of corrosion or cathodic protection data, such as structure maps, test point reads, rectifier reads, bond reads, gas service orders, gas leak repair reports, pipeline examination sheets, and computer data bases.

Coupling - A pipe fitting that connects the ends of two pipes. Common coupling types include threaded, welding, heat fusion or mechanical.

- **Mechanical Bolted** - The gasket compression is obtained by tightening long bolts connecting the follower at one end of the coupling body or middle ring to the follower on the opposite end of the coupling.
- **Mechanical Nut** - The coupling body is threaded on both ends, usually a male thread. The follower or nut has a matching thread usually a female thread. The gasket compression is obtained by tightening the nut.
- **Mechanical Stab** - A one piece self contained coupling used only on polyethylene plastic pipe. The plastic pipe is stabbed into the coupling. "O" rings provide seals against the exterior pipe wall. "Grippers" grab and prevent the pipe from being pulled out.

Covered Task - Those task(s) which can affect the safety or integrity of the pipeline.

Critical Areas - Gas main locations such as exposed main, main attachment to bridges, and areas of external loading where abnormal conditions may require special surveys or patrols.

Critical Interference Bond - An interference bond whose failure would jeopardize protection of the connected structure.

Cubic Foot (CF) - A three-dimensional volume one foot wide by one foot long, by one foot high.

Cubic Feet per Hour (CFH) - The average corrected volume of gas measured in one hour.

Curb Valve (also called property line valve, curb cock, curb tee) - A type of shutoff valve that provides immediate access for controlling the flow of gas in the service line normally installed near the property line.

Customer Meter - The meter that measures the transfer of gas from an operator to a consumer.

Delivery Station - Custody transfer point where AIC takes receipt of interstate gas supply.

Dent - A local depression in the pipe surface caused by mechanical damage that produces a gross disturbance in the curvature of the pipe without reducing the pipe wall thickness.

Department of Transportation (DOT) - Federal regulatory agency that regulates pipeline safety.

Design MAOP - The highest pressure that a new or replaced pipeline segment could ever be expected to be operated. Design MAOP replaces the term NFDP, New Facilities Design Pressure that was used by one of the legacy companies.

Diaphragm - A flexible membrane separating two chambers. Typically used in regulators, relief valves and meters.

Differential Pressure - The difference in pressure between any two points in a continuous system. The differential pressure is also called pressure drop.

Distribution Center - The initial point where gas enters the piping used primarily to deliver gas to customers who purchase it for consumption as opposed to customers who purchase it for resale. Examples of a distribution center could be at: metering location, pressure reduction location or where there is a reduction in the volume of gas such as a lateral off a transmission line. Transmission pipelines that operate downstream of a Distribution Center are considered to be operated as part of a distribution system.

Distribution Main - A pipeline which is not classified as transmission or gathering line.

Distribution System - The network of pipelines, mains, pressure reduction stations, valve or metering stations, service piping and equipment which are involved with the delivery of gas to customers for their consumption downstream of a Distribution Center.

Director Region Electric - Management employee responsible for Region Electric Operations.

Director Region Gas - Management employee responsible for Region Gas Operations.

Documentation - Recorded or pictorial information which describes, defines, specifies, reports or certifies activities, requirements, procedures, or results.

Double Random Pipe - A term used to describe a joint of pipe approximating 42 feet in length.

Downhole - The portion of an underground natural gas storage facility from the first flange attaching the wellhead to the piping equipment and continuing down the well casing to and including the storage reservoir.

Ductile Iron - A cast ferrous alloy material in which the free graphite present is in a spherical form rather than a flake form. It is less brittle than cast iron.

Easement - A formal permission granted by landowners for installation and maintenance of facilities. Easements are commonly referred to as Right-Of-Way grants.

Electric Resistance Weld pipe (ERW) - Pipe that has a straight longitudinal seam produced without the addition of filler material by the application of pressure and heat obtained from electrical resistance.

Electrical Survey - A series of closely spaced pipe-to-soil readings over pipelines which are subsequently analyzed to identify locations where a corrosive current is leaving the pipeline.

Electrofusion - A process used to join a plastic fitting to plastic pipe by introducing a controlled electric current to embedded wires inside the fitting. The wires produce heat, melting the plastic inside the pipe and bonding them together. The plastic fitting has internal electric coils which are heated by an electronic processor.

Electrolysis - A foreign source of electrical current which causes corrosion.

Electrolyte - The electrically conductive environment containing the anode and cathode.

Emergency - A situation involving gas facilities that may endanger life, damage property, or disrupt normal service. AOC (abnormal operating condition) is precursor.

Emergency Valve (also called critical valve, fire valve or key valve) - A designated valve that provides for the rapid shutdown of a piping system or segment of a piping system, that provides optimum control of gas flow in emergency situations.

Energized - Connected to an energy source or containing residual or stored energy.

Engineering Critical Assessment (ECA) - Documented analytical procedure based on fracture mechanics principles, relevant material properties (mechanical and fracture resistance properties), operating history, operational environment, in-service degradation, possible failure mechanism, initial and final defect sizes, and usage of future operating and maintenance procedures to determine the maximum tolerable sizes for imperfections based upon the pipeline segment maximum allowable operating pressure.

Entirely Replaced Onshore Transmission Pipeline Segments – For the purpose of § Part 192.179 NS 192.634, where 2 or more miles, in the aggregate, of onshore transmission pipeline have been replaced within any 5 contiguous miles of pipeline within any 24-month period.

Environmental Protection Agency (EPA) - Federal agency which regulates environmental impacts to air, water and noise.

Ethane (C₂H₆) - A hydrocarbon component of natural gas which has two atoms of carbon and six atoms of hydrogen to each molecule. Ethane is commonly referred to as the "finger print" of natural gas.

Excavation - A cavity, trench, or depression in the earth's surface, formed by earth removal.

Excess Flow Valve (EFV) - A valve designed to shut off the flow of gas when the flow rate exceeds the designed rate.

Expansion Joint - A provision, usually in piping, that accommodates the mechanical movement set up by contraction and expansion due to temperature changes in the piping system.

Exposed Underwater Pipeline - An underwater pipeline where the top of the pipe protrudes above the underwater natural bottom (as determined by recognized and generally accepted practices) in water less than 15 feet deep, as measured from mean low water.

Farm Tap - Gas regulation and over pressure protection equipment installed within a service line that is branched from a transmission, high pressure distribution, or gathering line to deliver gas to a customer and serves no more than two (2) service risers.

Fillet Weld - A roughly triangular cross-section generally used in a socket joint or tee joint which frequently joins 2 surfaces at right angles to each other.

Fire Extinguisher Locations - There are 3 location categories:

1. On the jobsite – fire extinguisher is located on the truck in the general vicinity of the work being performed.
2. At location of the work – fire extinguisher is off the truck and located near where the work is being performed.
3. Manned – qualified individual is actively manning the fire extinguisher near where work is being performed.

Flame Ionization Unit (FI) - Portable device that burns a hydrogen/nitrogen gas mixture to continuously analyze an atmospheric sample for combustible gas.

Flange - A round metal plate that is bolted to a matching plate to accomplish a pipe connection. A gasket is placed between the two plates to seal the joint.

Flow Control Station - Facilities for measuring or directing the flow of gas.

Foreign Pipeline Crossing - An Ameren main crossing a foreign pipeline which is using an impressed current system for protection.

Foundation - The base which supports a structure in which a human can enter and gas could accumulate. This does not include a pad used to support such things as: sign, stand-by generator, antenna, tower, grain bin, or structure not meant for human entry.

Franchise - An agreement between a city and a public utility permitting use of streets, alleys and public ways and granting the right to install and maintain facilities.

Fuel Line - The customer-owned gas piping downstream from the outlet of the customer meter or Ameren-owned pipe, whichever is further downstream.

Gas - Natural gas, flammable gas, or gas which is toxic or corrosive.

Gas Compliance System (GCS) - Company system utilized to manage and document various gas operating and maintenance activities. Beginning December 1, 2014, GCS was replaced with a suite of compliance products; Maximo, ClickMobile, and ClickSchedule

Gas Detection Instrument - An electronic Combustible Gas Indicator equipped with a PPM sensor capable of detecting a 50 PPM gas-in-air concentration.

Gas Engineering - Region based Gas Engineer

Gas Field Personnel - Craft or contract worker responsible for performing the physical work.

Gas Operations and Services - Gas Transmission, Gas Tech Engineering, Corrosion Control, Pipeline Integrity, Gas Storage, Gas Tech Services, Training and Quality Assurance, Compliance and Standards and Procedures.

Gas Standard (GS) - A document that provides guidance for the design and construction of gas facilities.

Gas Storage Well - A well drilled for input and/or withdrawal of natural gas or manufactured gas in a gas storage field.

Gas Superintendent - Management employee responsible for Region Gas Operations.

Gas Supervisor - Management employee responsible for local Gas Operations.

Gathering Line - A pipeline that transport gas from a current production facility to a transmission line or main.

Gauge - A device which will measure gauge pressure.

Gauge Pressure (PSIG) - The pressure one would read on a typical spring gauge or recording chart. The pressure above atmospheric pressure.

Generalized Corrosion - Corrosion over a large area of a metal pipe surface, resulting in flaking of the pipe wall and/or corrosion pitting grouped closely enough to affect the overall strength of the pipe.

Note: A large area is an area that cannot be covered with a single repair fitting.

Gouge - Local damage caused by mechanical or forceful removal of metal from a local area on the surface of the pipe that may work harden the pipe and make it more susceptible to cracking.

Graphitization - A form of corrosion associated with cast iron pipe.

Half Cell - A standard reference cell, usually a copper rod in a copper sulfate solution, used for cathodic protection measurements.

Half Sole - A patch plate with rounded corners welded on a steel main or service as a repair or reinforcement. (Not approved for transmission mains)

High Consequence Area - A transmission line segment that Ameren has determined meets one of the following requirements:

- The potential impact circle touches or contains an Identified Site.
- Has twenty (20) or more buildings intended for human occupancy within the potential impact circle

High Pressure Distribution Main - Any main connecting a supply source of natural gas to a distribution system. High pressure distribution mains are not classified as transmission but have a MAOP over 60 psig.

Holiday - A pipeline coating defect, such as a break or hole in the protective coating on steel pipe. These defects can expose the pipe to corrosion at that point.

Holiday Detector - An electronic device, commonly referred to as a Jeep, used to detect holidays in pipeline coating.

Hoop Stress - Circumferential stress on the pipe wall produced by pressure in the pipe.

Hot Spot - An area in which active corrosion leaks are found.

Hot Tap - A connection made to a main while it is in operation. The connecting and tapping is done while the facility is under pressure.

Hot Work - Any process that can be a source of ignition when flammable material is present or can be a fire hazard regardless of the presence of flammable material in the workplace. Common hot work processes are: flame cutting, welding, riveting, brazing, soldering, grinding, thermite welding, cadwelding, applying torch flame to pipe, or other fire or spark-producing operations.

Inert Gas - A gas that will not react or combine with other elements. Inert gas will not burn.

In-Service Welding - Pipeline maintenance welding is welding on a pipeline or piping system that contains a gas or liquid such as natural gas or similar products.

Interference - An electrical disturbance on a metallic structure caused by stray current.

Interference Bond - Wire used to provide electrical current flow between two sections of pipe.

Isolated Services - A steel service line which is not welded or electrically bonded to a main.

J.U.L.I.E. (JULIE) - Joint Utility Locating Information for Excavators, also known as the Illinois One Call System.

Leak - Any unintended escape of natural gas.

Leak Re-Check - A surveillance performed after a leak repair has been made. Frequency is within 30 days of repair.

Leak Surveillance - An investigation to determine leak class based upon hazard potential and volume of natural gas found. Leak surveillances are performed on both new and existing leaks where no repairs are made. Frequency depends upon leak classification.

Leak Survey - A systematic inspection made of pipeline facilities for the purpose of finding leaks.

Leak Test - A test which subjects a natural gas pipeline or facility to a pressure which verifies there are no defects in the material, connections or joints which could result in a hazardous leak.

Line Section - A continuous run of transmission line between adjacent compressor stations, between a compressor station and storage facilities, between a compressor station and a block valve, or between block valves.

Load - A means of expressing the quantity of gas required over a period of time. (i.e., cfh, mcfh, mcf/d)

Localized Pitting Corrosion - Pitting concentrated over a small area.

Note: A small area is an area that can be covered with a single repair fitting.

Locating - The process of finding and marking the location of an underground facility.

Lock Out - The placement of a lock out device on an energy isolating device, i.e. valve, electrical breaker, in accordance with established procedures for ensuring that the energy isolating device and the equipment being controlled cannot be operated until the lock out device is removed.

Lock Out Device - A device that utilizes a positive means, such as a key or combination lock, blank flanges or bolted slip blinds, to hold an energy isolating device in a safe position and prevent the energizing of a machine or equipment.

Lock-up - The increase in pressure necessary to provide a bubble tight shut-off for a regulator.

Low Pressure Distribution System - A distribution system in which the gas pressure in the main is substantially the same as the pressure provided to the customer, 4 inch w.c to 14 inches w.c.

Low Pressure - A main, service, or gas system with a MAOP less than 2 psig.

Lower Explosive Limit (LEL) - Lowest concentration of gas-in-air that will support combustion. For natural gas, the LEL is 5.0% gas-in-air.

Main - A distribution line that serves as a common source of supply for one or more service lines.

Malleable Iron - A mixture of iron and carbon, including small amounts of silicon, manganese, phosphorous and sulfur which, after cast, is converted structurally by heat treatment into primarily a matrix of ferrite containing nodules of tempered carbon. (non-weldable)

Manual Service Line Shut-Off Valve - A curb valve or other manually operated valve located near the service line that is safely accessible to operator personnel or other personnel authorized by the operator to manually shut-off gas flow to the service line, if needed.

Manufactured Home - NFPA 54: Defines a manufactured home as a structure, transportable in one or more sections, which is built on a chassis and designed to be used as a dwelling, with or without a permanent foundation when connected to the required utilities. A mobile home, trailer, or manufactured home will be considered a manufactured home for this policy.

Masking Agent - An odor control product which covers up unpleasant odors.

Maximo - Asset Management System utilized for Gas Compliance activities.

Maximum Allowable Operating Pressure (MAOP) - The maximum pressure at which a pipeline facility or segment of a main or service may be operated during normal operations.

Maximum Emergency Pressure (MEP) - The maximum pressure at which a pipeline or segment of a pipeline may operate for a period of time during an emergency or equipment failure. Base on the pressure class, the MEP for a pressure system is defined as follows:

Pressure Class	System MAOP	Maximum Emergency Pressure
----------------	-------------	----------------------------

Low Pressure	4" W.C. to 14" W.C.	27.6 W.C.
Distribution Pressure 1	1 PSIG to 12 PSIG	MAOP + 50%
Distribution Pressure 2	12 PSIG to 60 PSIG	MAOP + 6 PSIG
High Pressure Distribution & Transmission	Over 60 PSIG	MAOP + 10% or 75% SMYS, whichever is less

Meter - A mechanical device which measures the volume of gas delivered from the operator to the customer. Common types of meters are:

- Diaphragm - A positive displacement meter in which gas passes through a series of chambers which records the volume of gas. Most domestic meters are diaphragm type meters.
- Orifice - A meter for measuring gas by measurement of the pressure differential across a plate having a precisely cut hole in the center. Orifice meters are commonly used for high volume non billing applications, such as a storage field.
- Rotary - A positive-displacement meter in which gas passes through a series of impellers which turns a rotor recording the volume of gas. Most rotary meters are commonly used for commercial or small industrial applications.
- Turbine - A meter that records the flow of gas based upon the velocity of gas flowing through the turbines. A turbine meter is commonly used in very high volume applications.
- Ultrasonic - A meter that records the flow of gas by the absolute digital time travel (ADTT) measurement method.

Meter Set Assembly (also called Meter Header or Meter Loop) - All components from the meter valve to the customers piping.

Meter Valve (also called Wedge-seal, meter stop or lock cock) - A valve connecting the inlet service piping to the meter set assembly which is used to turn gas flow on or off.

Methane (CH₄) - The lightest of the hydrocarbons and has one atom of carbon and four atoms of hydrogen for each molecule. Natural gas is normally 87% methane.

Moderate Consequence Area (MCA) - A transmission line segment that Ameren has determined meets one of the following requirements, and is not considered an HCA:

- Has five (5) or more buildings intended for human occupancy within the potential impact circle.
- The potential impact circle touches or contains any portion of paved surface, including shoulders, of a designated interstate, freeway, expressway, or other principle four or more lane arterial roadway as defined in the Federal Highway Administration's "Highway Functional Classification Concepts, Criteria, and Procedures."

Migration - Movement of gas, normally below ground from one place to another.

Multipliers (also called Pressure Factors or Billing Constants) - Correction factors used to calculate the volumes of gas when metering at approved elevated pressures where a correcting device is not installed.

Multi-Fed System - Systems with more than one source of gas supply.

Natural Gas Reading - A reading of 2.0% LEL or less is considered 0% gas for leak classification/documentation purposes and is not a reportable reading if the reading is greater than five (5) feet from a foundation wall.

Navigable Waterway - Navigable waters of the US as defined in 33 CFR Part 329 are those waters subject to ebb and flow of the tide and/or are presently used, or have been used in the past, or may be susceptible for use to transport interstate or foreign commerce. Naviga-

ble waterways in Ameren Illinois service territory include the Illinois River, Mississippi River, and lower portion of the Kaskaskia River.

NDT - Nondestructive Testing: A noninvasive examination of the integrity of a weld that does not impair its serviceability. At Ameren Illinois nondestructive tests include: radiographic testing, magnetic particle testing, and liquid penetration testing.

Nitrogen - A colorless, odorless, non-flammable gas often used for pressure testing and purging. Nitrogen forms 80% of the atmosphere.

Non-Essential Business Operations - Construction and maintenance activities that do not impact the movement of gas through the system, such as training, meetings, business travel, DOT compliance activities, etc.

Non-routine Visitors - Those visitors who are at a Critical Gas Facility at their own invitation including government inspectors and salespersons.

Notification of Potential Rupture – The notification to, or observation by, an operator of indicia identified in § 192.635 of a potential unintentional release of a large volume of gas from a pipeline.

Observation Well - A well drilled to monitor subsurface conditions in or around a gas storage field.

Odorant - A blend of 2 or more liquid ingredients used to give natural gas a distinctive, recognizable odor.

Odorant Intensity Test - A test routinely performed on each odorized system to measure the percentage of natural gas-in-air at which the odorant becomes readily detectable to a person with a normal sense of smell. The operator uses an Odorometer or Odorator to measure the natural gas-in-air concentration.

Odorization - The accurate addition of odorant to natural gas and propane.

Odorizer - A device which introduces odorant into natural gas.

- Bypass - Odorizers in which a very small portion of the total volume of natural gas to be odorized is bypassed through the odorizing unit where it becomes saturated with odorant vapor, then is mixed with the main line gas stream.
- Drip - Odorizers in which odorant is gravity-fed from a pressure equalized vessel. Liquid head in the odorant storage vessel forces odorant through the unit into the pipeline.
- Liquid Injector Pump - Odorizers in which odorant is injected into the pipeline by a pump, generally operated by an injection rate controller.
- Wick - Odorizers in which a wick extends from the odorant into the main line gas stream and the odorant vapors are absorbed by the gas.
- Vaporization - Odorizers in which a small portion of gas becomes saturated after coming in contact with odorant vapors. Saturated gas is then mixed with the main line gas stream.

Odorometer or Odorator - An instrument that mixes odorized natural gas with air and allows the operator to read the percent gas concentration at which gas odor is readily detectable.

Operational Inspection - An inspection performed at a regulator station to ensure that the equipment is operating properly and at the correct set pressures. An operational inspection does not require the disassembly of the equipment.

Operating and Maintenance (O&M) Plan - A document that identifies the required activities to ensure compliance with regulatory requirements.

Outage Analysis System (OAS) - Company system utilized to report, manage and document customer complaints and gas leak investigations.

Over Pressure Protection Station - A pressure relief valve installed in a separate location from the regulator station.

Over Pressure Protection (OPP) - The means of protecting a system from exceeding the Maximum Emergency Pressure (MEP).

Oxygen - A colorless and odorless gas that forms approximately 21% of the atmosphere by volume.

Patrol - Periodic visual inspection of pipeline facilities for signs of gas leakage or conditions that could be detrimental.

Perimeter Type Leak Survey - A survey conducted along the outside building wall where the fuel line enters the building and along the nearest adjacent wall to include checks around windows, crawl space vents and other openings.

Permanent Repairs - A repair which allows a facility to be operated at its design MAOP.

Personal Protective Equipment (PPE) - Equipment such as hard hats, safety glasses and respirators used to protect you from dangers on the job and required in certain work situations.

Pig - A device inserted into a pipeline, which travels throughout the length of the pipeline, and is driven by the product flow. Pigs typically fall into 2 categories:

- Conventional or Utility Pigs - Used for cleaning, separating, or dewatering.
- Intelligent Pigs or In-line Inspection Tools - Provide information on line condition, as well as extent and location of problems.

Pipe - Any pipe or tubing used in the transportation of gas, including pipe-type holders.

Pipeline Facility - Pipelines, right-of-way, and any equipment, facility or building owned by Ameren and directly connected to and used in the transportation of gas or in the treatment of gas during the course of transportation.

Pipe-to-Soil (P/S) - The voltage difference between a pipe's metallic surface and electrolytes measured with a reference to an electrode in contact with electrolytes (soil).

Pit - A subsurface structure housing piping and piping components that has a volumetric internal content of less than 200 cubic feet and constructed in a manner that would allow gas to accumulate.

Polyethylene Pipe (PE) - A pipe made of lightweight thermo-plastic that is resistant to chemicals and moisture. PE2406/2708 is a medium density yellow polyethylene pipe with an maximum MAOP of 60 psig. PE 3408/4710 is a high density black with yellow stripe polyethylene pipe with an maximum MAOP of 100 psig.

Poly Vinyl Chloride Pipe (PVC) - A pipe made of PVC resin which is semi-rigid and is joined by the use of a solvent.

Portable Standards - Instruments that utilities use in the field or the meter shop to test the accuracy of auxiliary and tertiary equipment, transmitters, and other equipment associated with correcting a meter's output.

Potential Impact Circle (PIC) - A circle centered on transmission main that has a radius equal to the potential impact radius (PIR). The PIC is used to determine the location and size of a High Consequence Area (HCA) and Moderate Consequence Area (MCA).

Potential Impact Radius (PIR) - The radius of a circle within which the potential failure of a pipeline could have significant impact on people or property. The PIR is determined by the formula, $PIR = 0.69\sqrt{(p \cdot d^2)}$ where PIR is the radius of a circular area in feet surrounding the point of failure, p is the Maximum Allowable Operation Pressure (MAOP) in the pipeline seg-

ment in pounds per square inch (psi) and d=outside nominal diameter of the pipeline in inches.

Primary Inspection - An inspection performed at a regulator station which includes the disassembly of equipment to inspect the internal parts and replace any parts that are worn or defective.

Production Fluid - Liquids, regardless of chloride and total dissolved solids content, that is produced in conjunction with oil or natural gas production or natural gas storage operations.

Promptly - To act immediately without undue delay.

Protective System - A method of protecting personnel from cave-ins or collapse of adjacent structures. Protective systems include trench box, shoring and sloping.

Public Place - A location that is not restricted to specific persons and is generally open to all persons in a community. A public place includes churches, schools, and commercial property, as well as any publicly owned right-of-way or property that is frequented by people.

Pull-out - A situation that occurs when internal or external forces that act upon the pipe's centerline pull apart pipe ends joined by couplings.

Purging - The process of removing gas from or putting gas into a main or service line.

Qualified Individual - An individual who has been evaluated and can perform assigned covered tasks and is able to recognize and react to abnormal operating conditions.

Qualified Welder - A person who has welded successfully to the code requirements set forth in the DOT CFR 192 and API 1104. Said welder shall demonstrated by knowledge and ability, both written and hands-on weld testing. The welder must produce an acceptable weld that, at a minimum, meet Code and are in accordance with Company's qualified welding procedures.

Qualified Welding Inspector - An individual who has demonstrated the skills, training, knowledge and experience required to ensure the appropriate qualified welding procedures are being followed and proper procedures are being utilized to determine the acceptability of the welds.

Rectifier - An electrical device that converts AC to DC power, to impress DC energy between the piping and the ground bed anode, for cathodic protection of the pipe.

Reference Standards - Instruments that utilities use only for verifying the accuracy of portable standards, and whose accuracy is traceable back to the national standard maintained by the National Institute of Standards and Technology (NIST) or its successor. **Reference Standards are for use in a shop environment only and never taken to the field.**

Regulator - A mechanical device that controls the flow of gas at a constant pressure to meet downstream demand. Common types of regulators are:

- Monitor - A pressure regulator set in series with another pressure regulator, for the purpose of providing automatic over pressure protection in the event of a malfunction of the primary regulator.
- Pilot Loaded - Type of regulator loading system where a small regulator is used as the control for the main regulator. The pilot amplifies the change in downstream pressure, reducing the variance from the main regulator set point.
- Spring Loaded - The mechanical method of loading a regulator with a counterbalance force on the diaphragm to establish the set point.

Regulator Set-point - The desired downstream pressure controlled by the regulator during gas system demand.

Regulator Station - (city gate, take point, pipeline station, town border station) - Pressure regulating station consisting of equipment installed for the purpose of automatically controlling the flow and regulating the pressure in the downstream main to which it is connected. Included are piping and auxiliary devices such as valves, control instruments, control lines, the enclosure, and ventilation equipment.

Relief Valve - A safety valve that opens automatically to prevent over-pressurization by venting excess gas to atmosphere. A relief valve is a type of over pressure protection.

- Pilot Loaded - Type of loading system where a small regulator is used as the control. The pilot amplifies the change in downstream pressure, reducing the variance from the main set point.
- Spring Loaded - The mechanical method of loading a relief valve with a counterbalance force on the diaphragm to establish the set point.

Remote Control Valve - Equipped with electric or gas powered actuators to open or close a designated valve based on a command signal from a remote locations.

Replaced Service Line - A gas service line where the fitting that connects the service line to the main is replaced or the piping connected to this fitting is replaced.

Residential Service - A single or branch service line serving a gas meter or gas meters that are qualified to be billed under Ameren Illinois' Residential Gas Delivery Service GDS-1 rate as specified in the Ameren Illinois Gas Service Tariff- Schedule 2.

Retirement - An abandoned facility removed from Ameren property accounting records.

Right-Of-Way (ROW) - A strip of land, granted by deed or easement, in which facilities are installed.

Routine Visitors - Those visitors who have a recurring need to be at a Critical Gas Facility and are familiar to employees such as refuse collectors, UPS or FedEx delivery persons, mail carriers, cleaning staff, etc.

Rupture Mitigation Valve (RMV) – An automatic shut-off valve (ASV) or a remote-control valve (RCV) that a pipeline operator uses to minimize the volume of gas release from a pipeline and to mitigate the consequence of a rupture.

Saddle - A fitted plate, held in place by clamps, straps or welding, over a hole in a gas main, and into which a branch line or customer-service connection is connected.

SCADA - Supervisory Control and Data Acquisition system: Computer based system or systems used by a controller in a control room that collects and displays information about a pipeline facility and may have the ability to send commands back to the pipeline facility.

Secondary Gas Facilities - Ameren maintains a secondary list of gas facilities the Company considers to be important for the purpose of maintaining the reliability and operability of the Ameren gas system. These facilities are not considered to be a viable terrorist target, important to the nation's energy infrastructure or national defense, or likely to be used as a weapon to harm people or cause mass casualties.

The list of secondary gas facilities will be provided to the applicable local supervision. The risk control measures, in part or in whole, identified in this document may be applied to these facilities based upon operating requirements and the national and Ameren threat level.

Security Threat Alarm Levels - the National Terrorism Advisory System (NTAS) will only issue security threat alarms when credible information is available.

- Elevated Threat Level - warning of a credible terrorist threat against the United States.

- **Imminent Threat Level** - warning of a credible, specific, and impending terrorist threat against the United States.
- **Sunset Provision** - individual threat alert is issued for a specific time period and then automatically expires.

Service Line - A pipe that transports gas from a common source of supply to: a) an individual customer, b) two adjacent or adjoining residential or small commercial customers, or c) multiple residential or small commercial customers served through a meter header or manifold. A service ends at the outlet of the customer meter or at the connection to the customer piping, whichever is further downstream, or at the connection to customer piping if there is no meter.

Service Line Serving a Single Family Residence (SFR) - A gas service line that begins at the fitting that connects the service line to the main and serves only one single family residence.

Service Regulator - A mechanical device that controls the flow of gas at a constant pressure to meet downstream customers demand. Standard delivery pressure is normally 7 inches of water column.

Shall - Mandatory; must do.

Shoring - A worker protection method that uses structural components to support the walls of an excavation.

Short - An unintended electrical contact between two metal structures.

Shorted Pipeline Casing - A casing in direct metallic contact with the carrier pipe.

Should - A management decision incorporated into an operating practice or policy that is to be followed if at all possible.

Slam Shut Valve - A device designed to protect piping and equipment from either under or over pressure conditions by automatically activating at a pre-set pressure. This device requires a manual reset. Slam shut valve is a type of over pressure protection.

Single Random Pipe - A term used to describe a joint of pipe. A length of pipe approximately 21 feet in length.

Sloping - A method of worker protection based on digging the walls at an angle, so the trench is wider at the top than at the bottom.

Sniff Test - Is a smelling assignment that relies on the human olfactory system to detect the presence of odor in natural gas. Each sniff test is accomplished by inhaling through the nose to substantiate the tester is alerted to the presence or absence of odor in natural gas.

Specific Gravity - The weight of a gas in relation to the weight of air. A gas with a specific gravity less than 1.00, like natural gas (which is typically about 0.60), is lighter than air and will rise. A gas with a specific gravity greater than 1.00, like propane (which is typically about 1.50), is heavier than air, and will settle near ground level.

Specified Minimum Yield Strength (SMYS) - The specified minimum yield strength of the steel pipe.

Split Sleeve - A sleeve for pipe that is cut in half longitudinally so it can be fitted to a pipe in service. Provisions are made for bolting, clamping or welding the sleeve in place.

Spoil - The material, dirt, rock, soil, etc., removed or excavated from a trench or excavation.

Steel - A conductive metal alloy, consisting of mostly iron and small amounts of carbon, manganese, and other metals. (weldable).

Stray Current - Current in paths other than the intended circuit which can affect cathodic protection on pipe.

Strength Test - A test that qualifies the maximum allowable operating pressure (MAOP) of a gas pipeline or gas facility, by applying a test pressure equal to or greater than 1.5 times the design MAOP.

Surveillance - A periodic visual inspection of pipeline facilities and the review / analysis of records.

System MAOP - The maximum allowable operating pressure designation for an existing operating gas system or facility.

Tag Out - The placement of a tag out device on an energy isolating device, in accordance with established procedures to indicate that the energy isolating device and the equipment being controlled cannot be operated until the tag out device is removed.

Tag Out Device - A prominent warning device, such as a tag, which can be securely fastened to an energy isolating device in accordance with established procedures to indicate the energy isolating device and the equipment being controlled may not be operated until the tag out device is removed

Temperature Compensation - Term used mainly in the gas metering of gas. The capability to adjust the gas volume measured for changes in the temperature of the gas.

Tertiary Equipment - means a device that electronically converts signals from a gas measurement system (meter or auxiliary equipment or both) to a useful form such as flow rate (for example, flow computers and remote monitoring devices (RMD)).

Test Duration - The amount of time (typically in minutes or hours) for which a pressure test should be held. Test duration begins only after the test pressure has stabilized.

Test Medium - Water, air, natural gas, or nitrogen.

Test Station (also called test lead) - A test box, wire or other point on underground piping where electrical contact can be made to monitor the cathodic protection level.

Therm - A quantity of heat equivalent to 100,000 British Thermal Units (B.T.U.). Approximately the same heat content as 100 cubic feet of natural gas.

Tie in - Connecting a new gas system to an existing gas system.

Tie-In Test - A leak test performed on the final tie-in connection(s) of a tested segment of pipeline. The tie-in connection will be checked with leak detection fluid or leak detection instrument with the pipeline at normal operating pressure.

Tolerance Zone - (for excavating and locating purposes)

Illinois Definition: The approximate location of underground utility facilities defined as a strip of land at least 3' wide, but not wider than the width of the underground facility plus 1 1/2' (18 inches) on either side of such facility based upon the markings made by the owner or operator of the facility.

Transmission Line - A pipeline, other than a gathering line, that meets any of the following requirements:

- Transports gas from a gathering line or storage facility to a distribution center, storage facility or large volume customer that is not down-stream of a distribution center,
- Operates at 20% or more of the Specified Minimum Yield Strength (SMYS) or

Note: AIC classifies pipelines with MAOP of 20% SMYS or greater as transmission.

- Transports gas within a storage field or

- Other main as designated Transmission by Ameren's Pipeline Integrity Group.

Note: Contact Pipeline Integrity with questions concerning identification of Transmission facilities.

Transportation of Gas - The gathering, transmission or distribution of gas by pipeline or the storage of gas, in or affecting interstate or foreign commerce.

Trench - A narrow excavation in relation to its length made below the surface of the ground.

Union - A pipe fitting which connects two sections of pipe by means of a threaded connecting collar.

Uncontaminated Soil - Means soil that does not contain contaminated in concentrations that pose a threat to human health and safety and the environment.

Underground Facility (or Facilities) - Means and includes wires, ducts, fiber optic cable, conduits, pipes, sewers and cables and their connected appurtenances installed beneath the surface of the ground by a public utility.

Underground Natural Gas Storage Facility (UNGSF) - A facility that stores natural gas in an underground facility incidental to the transportation of natural gas, including: (1) a depleted hydrocarbon reservoir, (2) an aquifer reservoir or (3) a solution-mined salt cavern. In addition to the reservoir or cavern, a UNGSF includes injection, withdrawal, monitoring and observation wells; wellbores and downhole components; wellheads and associated wellhead piping; wing-valve assemblies that isolate the wellhead from connected piping beyond the wing-valve assemblies; and any other equipment, facility, right-of-way, or building used in the underground storage of natural gas.

Upper Explosive Limit (UEL) - The highest concentration of gas-in-air that will support combustion. For natural gas the UEL is 15.0% gas-in-air.

Valve - A mechanical device for controlling the flow of gases. Common types are ball, gate, globe, needle, plug and diaphragm.

- Ball - A quarter-turn valve that uses a ball to control flow. The ball turns inside the valve to allow more or less flow through a hole called a port.
- Gate - A multi-turn valve that operates by placing a metal disc, called a gate, across the opening of the pipe.
- Globe - A multi-turn valve that operates by raising and lowering a disc off or on to the seat. The flow bends inside the valve and the disc is in a horizontal position with the seat below.
- Plug - A quarter-turn valve that uses a rectangular plug to control flow. The plug turns inside the valve to allow more or less flow through a hole, called a port.

Vault - A subsurface structure housing pipe and piping components that has volumetric internal content of 200 cubic feet or more and constructed in a manner that would allow gas to accumulate.

Vent Limiter - Vent limiters are designed for use indoors and in spaces where limiting the amount of gas escapement due to diaphragm failure is critical. Ball check permits free inhalation for fast regulator-diaphragm response on opening cycle, but limits gas escapement to within ANSI standards, should a diaphragm rupture. Vent limiters must be screwed directly into the regulator vent boss and no intervening piping is allowed. Vent limiters should not be used outdoors if they are exposed to the environment.

Weak Link - Device or method used when pulling polyethylene pipe, typically through methods such as horizontal directional drilling, to ensure that damage will not occur to the pipeline by exceeding the maximum tensile stresses allowed.

Weld - The joining of 2 sections of steel by heating the metal and allowing the metal to flow together with the application of a filler material.

Welder - A person who performs manual or semi-automatic welding.

Welding Operator - A person who operates machine or automatic welding equipment.

Welding Procedure Qualification Report (WPQR) - Documentation of all essential variables in the Company's Welding Procedure Specification (WPS) will produce a weld that meets Section 5 of API 1104 code requirements. Variables such as process, amperage, voltage, type/size of electrode, travel speeds, number of passes, direction of travel, pre-heat temperature, root opening, and cleaning method are documented for each WPS. WPQR contains results of the destructive testing that documents the weld passes API 1104 qualifying standards.

Welding Procedure Specification (WPS) - A document which describes how production and maintenance welding should be performed that will ensure sound welds and suitable mechanical properties. Document contains all of the essential variables required by Section 5 of API 1104 code that are to be followed by the welder.

Yardline - A residential customer's underground primary fuel line, where the gas meter set is more than three (3) feet from the outside wall of the residential premise being served by the gas meter.

End of Instructions.

Operator Qualification (OQ) Required?

NO.

Appendices

NONE.

Attachments

NONE.

Compliance Requirements

NONE.

Reference Documents

NONE.

Document Rescission

GLOS Glossary, December 1, 2021.

Revision Notes

Location of Changes	Summary of Changes

UNCONTROLLED IF PRINTED

INCD-Incident Reporting

INCIDENT REPORTING

October 1, 2020

INCD 0 Table of Contents

[INCD 1 Incident Reporting: Requirements](#)

Section 1.0 Purpose

Section 2.0 Scope

Section 3.0 Target Audience

Section 4.0 General

Section 5.0 Natural Gas Incident

Section 6.0 Potential Significant Event

Section 7.0 Courtesy Notification

Section 8.0 Service Interruption / Curtailment Notification

Section 9.0 Gas Supervisor and Supervisor Gas Storage Responsibilities

Section 10.0 Gas Compliance Responsibilities

Section 11.0 Post-Incident Alcohol and Drug Testing

Operator Qualification (OQ)

Appendices

Appendix A - Gas Compliance Reporting Matrix

Appendix B - State, and Federal Reporting Matrix

Appendix C - AIC, State and Federal Reporting Contacts

Appendix D - Ameren Corporate and AIC Internal Contacts

Appendix E - PHMSA Policy Reporting Suspected Natural Gas Explosions

Compliance Requirements

Reference Documents

Document Rescission

[INCD 2 Incident Reporting: Forms and Reference Materials](#)

Forms

PHMSA Incident Report Gas Distribution System, Form F 7100.1, Rev 4-2019.

PHMSA Incident Report Gas Transmission and Gathering Systems, Form F 7100.1, Rev 4-2019.

Potential Incident Report Form (April 1, 2020)

References

UNCONTROLLED IF PRINTED

Document Rescission

End Table of Contents.

Document Rescission

INCD 0 Incident Reporting: Forms and Reference Materials, April 1, 2020.

Revision Notes

Location of Changes	Summary of Changes
Not applicable.	This is a new document.

INCIDENT REPORTING

April 1, 2023

INCD 1 Requirements**1.0 Purpose**

This document describes Ameren Illinois' (AIC's) requirements for

- Determining reportable incidents in accordance with 49 CFR Parts 191 and 192; Title 62 Ch 1 IDNR 240; and Title 83 Ch I ICC SubCh D 501, 590, 595
- Reporting incidents in accordance with 49 CFR Part 191; ICC 501, 590, 595; IDNR 240; and 20 ILCS 3305 (IMEA 3305).
- Post-incident alcohol and drug testing in accordance with 49 CFR Part 199.

2.0 Scope

This document addresses the following:

[3.0 Target Audience](#)**[4.0 General](#)****[5.0 Natural Gas Incident](#)****[6.0 Significant Event](#)****[7.0 Courtesy Notification](#)****[8.0 Service Interruption / Curtailment Notification](#)****[9.0 Gas Supervisor and Supervisor Gas Storage Responsibilities](#)****[10.0 Gas Compliance Responsibilities](#)****[11.0 Post-Incident Alcohol and Drug Testing](#)**

Appendices:

[Appendix A - Gas Compliance Reporting Matrix](#)**[Appendix B - State and Federal Reporting Matrix](#)****[Appendix C - AIC, State and Federal Reporting Contacts](#)****[Appendix D - Ameren Corporate and AIC Internal Contacts](#)****[Appendix E - PHMSA Policy - Reporting Suspected Natural Gas Explosions](#)****3.0 Target Audience**

- | | |
|--|--------------------------------------|
| • Pipeline Safety Compliance Personnel | • Gas Storage Field Supervisor |
| • Gas Supervisors | • Gas Storage Field Personnel |
| • Gas Field Personnel | • Gas Control Personnel |
| • Gas Tech Services (GTS) Supervisor | • Gas Integrity Management Personnel |
| • Gas Tech Services (GTS) Personnel | • Public Awareness Group |

4.0 General (49 CFR §§ 191.3, 191.5, 191.9, 191.15; ICC 501.520, 590.10, 595.110, 595.120, 595.130; IDNR 240.1805)

UNCONTROLLED IF PRINTED

- 4.1 AIC shall inform state and federal agencies about certain events involving its pipeline systems and underground natural gas storage facilities (UNGSF). See [Appendix B](#).
 - 4.1.1 Additional AIC, state, and federal reporting may be required depending on the type of event and the course of its investigation.
- 4.2 AIC personnel shall strive to achieve AIC's several reporting time constraints.
 - 4.2.1 Potential natural gas incidents and other potential significant events require notification to Gas Compliance within 1 hour of confirmed discovery.

Confirmed discovery means when it can be reasonably determined, based on information available to the operator at the time a reportable event has occurred, based on a preliminary on-scene evaluation.

- 4.2.2 Gas field personnel or gas storage field personnel shall refer to the table in [Appendix A](#) - Gas Compliance Reporting Matrix for potential incidents requiring 1 hour notification to Gas Compliance.
- 4.2.3 If there is a potential reportable incident:
 - 1. Gas field personnel shall *promptly verbally* notify Gas Supervisor when there is a Potential Incident.
 - 2. Storage field personnel shall *promptly verbally* notify Supervisor Gas Storage when there is a Potential Incident.

Normally, Gas Supervisor or Supervisor Gas Storage receives initial notification about a Potential Incident through the Outage Analysis System (OAS). See [EMER 2.1](#) and [EMER 2.2](#). On-site information is provided by gas field personnel (see [EMER 2.4](#)) or storage field personnel responding to the OAS.

- 4.2.4 Following Supervisor notification, first priority is dealing with the situation to protect people first then property:
 - 1. Make the scene safe.
 - 2. Notify required emergency response agencies
 - 3. Attend to injuries
- 4.3 Gas Supervisor or Gas Storage Field Supervisor has the responsibility for identifying a potentially reportable natural gas incident and verbally notifying Gas Compliance immediately such that in Incident Report can be made within 1 hour of confirmed discovery.
 - 4.3.1 See [Appendix A](#) Gas Compliance Reporting Matrix
 - 4.3.2 See [Appendix C Table 1](#) Gas Compliance Contacts
 - 4.3.3 Gas Supervisor or Gas Storage Field Supervisor should refer to [Section 9.0](#) for additional responsibilities.

5.0 Natural Gas Incident (49 CFR §191.3, ICC 590.10, and IDNR 240.1805)

5.1 A natural gas incident is an event that involves the release of natural gas from an AIC pipeline system or UNGSF including downhole portion that results in one or more of the following:

5.1.1 A death.

5.1.2 Any personal injury requiring in-patient hospitalization.

- "Personal injury" includes injury to someone from the public, a customer, a contractor, an emergency responder, AIC personnel, etc.
- "In-patient hospitalization" means hospital admission and at least one overnight stay.

5.1.3 Estimated property damage including loss to AIC and/others, but excluding the cost of gas lost.

1. \$ 50,000 or more for reporting to ICC or IDNR
2. \$129,300 or more per §191.3 for reporting to PHMSA

The ICC falls under Section 595 of Illinois Title 83 Public Utilities, for reporting of Accidents or Incidents.

Under Section 595 the definition of an Incident is based on 49 CFR 191.3 as of January 1, 2011 which had the estimated property damage value at \$50,000.

IDNR 240.1805 - Estimate property damage is the result of a release of stored natural gas from the downhole portion of an underground natural gas storage facility.

5.1.4 Unintentional estimated gas loss of 3 million cubic feet or more.

5.1.5 An event that results in an emergency shutdown of an UNGSF.

Activation of an emergency shutdown system for other than an actual emergency does not constitute an incident.

5.1.6 Unintentional estimated gas loss from the downhole portion of an UNGSF of 500,000 cubic feet or more that occurs with 1/8 mile of a dwelling used as a residence, place of business or place of public assembly.

5.1.7 An event that is significant in the judgement of AIC, even though it did not meet the criteria above.

5.2 If the event meets the criteria of a Natural Gas Incident it is reportable to: See [Appendix B](#) State and Federal Reporting Matrix.

5.2.1 Pipeline and Hazardous Materials Safety Administration (PHMSA) via the National Response Center ([Appendix C Table 3](#)), and

5.2.2 Illinois Commerce Commission (ICC) ([Appendix C Table 2](#)), and

5.2.3 Illinois Department of Natural Resources (IDNR) ([Appendix C Table 2](#))

6.0 Significant Event (49 CFR §191.3(3), ICC 590.10)

6.1 A Potential Significant Event may involve one or more of the following.

6.1.1 Any personal injury requiring medical treatment.

6.1.2 An explosion.

PHMSA request any suspected natural gas explosion be reported even though AIC facilities were not involved.

6.1.3 A natural gas fueled fire with estimated property damage exceeding \$25,000.

6.1.4 Supply or pressure problems that cause curtailment of firm load to more than 50 customers.

6.1.5 Gas service interruption to 25 or more customers for durations of 8 hours or more.

6.1.6 Damage to any high-pressure distribution or transmission line.

6.1.7 Damage to any distribution main with an estimated repair time in excess of 8 hours excluding gas service interruption relight time.

6.2 Gas Compliance shall determine if a Significant Event is reportable as a Natural Gas Incident.

6.2.1 If the Significant Event is not reportable as an Incident, it may be reportable as a:

1. Courtesy Notification. Or
2. Service Interruption/Curtailment Notification.

7.0 Courtesy Notification

7.1 As soon as practicable, Gas Compliance may provide courtesy notification to ICC's Pipeline Safety Personnel about any of the following events.

7.1.1 Fire and/or Police Emergency Response to a release of natural gas from an AIC facility where gas migration requires any of the following:

1. Evacuation of *more than one* residential structure.
2. Evacuation of multiple occupancy buildings such as a restaurant, store, apartment, school, church, hospital, nursing home, factory, etc.
3. Closure of a major road, highway, railroad, etc.

7.1.2 News media response to a release of natural gas.

- 7.1.3 Odorant release resulting in an increase in odor/leak calls from the public.
- 7.1.4 Odorizer failure resulting in either over odorization or under odorization.
- 7.1.5 Potential significant events that are not deemed to be reportable as a Natural Gas Incident.

8.0 Service Interruption / Curtailment Notification

- 8.1 ICC and IEMA, [Appendix C Table 2](#), shall be notified when:
 - 8.1.1 Gas service is interrupted to more than 1,000 people (approximately 400 meters based upon 2.5 people per household).
 - 8.1.2 Supply or pressure problems cause AIC to curtail firm (contract) load to more than 50 customers.
- 8.2 As soon as practicable, notify ICC Consumer Services Division and Safety and Reliability Division personnel, [Appendix C Table 4](#), when:
 - 8.2.1 Gas service interruption to 50 or more customers for a period of 12 hours or more.

9.0 Gas Supervisor and Supervisor Gas Storage Responsibilities (49 CFR §192.605(b)(4))

- 9.1 Supervisor shall:
 - 9.1.1 Gather as much preliminary information about Potential Incident for the 1-Hour Report from contact with appropriate on-site field personnel and OAS messages.

Complete information is not necessary for the 1- hour report.
Rough estimates are expected and acceptable.

1. Brief description of Potential Incident
2. Summary of actions taken to date.
3. Preliminary information needed for the top portion of page 1, Potential Incident Report Form (see [INCD 2](#)). Include the following information:
 - 3 a. Location of event including address and county.
 - 3 b. Event date and time (include AM or PM).
 - 3 c. Pipe diameter, material, and pressure at time of event.
 - 3 d. Number of personal injuries requiring hospital admittance.
 - 3 e. Number of customers affected by gas service interruption. (Approximation only)
 - 3 f. Number of fatalities.
 - 3 g. Dollar value of property damage. (Indicate if it appears to be considerable)
 - 3 h. Indicate if gas released
 - 3 i. Cubic feet of gas released. (Give approximate length of time gas was blowing)

UNCONTROLLED IF PRINTED

3 j. Person providing information and time information provided (include AM or PM)

3 k. Weather conditions including wind strength and direction

9.1.2 Provide Gas Compliance with preliminary information for 1-Hour Report about Potential Incident.

9.2 If Gas Compliance personnel cannot be contacted, Supervisor shall notify appropriate Superintendent or Director.

9.3 Superintendent or Director will make the report to:

9.3.1 ICC. See [Appendix C Table 2](#)

And

9.3.2 PHMSA via NRC. [Appendix C Table 3](#) for NRC.

And

9.3.3 Notify Gas Compliance that the report has been submitted.

9.4 Coordinate with appropriate Superintendent concerning drug and alcohol testing if the Potential Incident results from tasks performed by AIC personnel. See [Section 11.0](#).

9.4.1 Review Ameren Supervisor Guidelines for Drug and Alcohol Testing. See [INCD 2](#).

10.0 Gas Compliance Responsibilities

10.1 Complete a Potential Incident Report Form (see [INCD 2](#)) based on information provided by Gas Supervisor or Supervisor Gas Storage (see [Subsection 9.1.1](#)) and any other sources.

10.2 Determine if the Potential Incident meets reporting criteria of:

10.2.1 [Section 5.0](#), Natural Gas Incidents.

10.2.2 [Section 6.0](#), Potential Significant Events.

10.2.3 [Section 7.0](#), Courtesy Notifications.

10.2.4 [Section 8.0](#), Service Interruption / Curtailment Notifications.

10.3 Report a Natural Gas Incident to PHMSA and ICC as follows.

10.3.1 The 1-Hour Report.

- The 1-Hour Report is based on the Potential Incident Report Form
- Complete information is not necessary for the 1-Hour Report.
- Provide a 24-hour telephone number for where more detailed information can be obtained.
- Record a report number if provided by recipient.
- Record recipient's name plus date and time of contact.

1. National Response Center (NRC). See [Appendix C Table 3](#).

UNCONTROLLED IF PRINTED

2. ICC. See [Appendix C Table 2](#).
3. Appropriate AIC internal notifications: See [Appendix D](#).

10.3.2 The 48-Hour Report.

1. Within 48 hours after the confirmed discovery of incident, to the extent practicable, revise or confirm 1-Hour Report filed with NRC and the ICC.
2. Revisions may include updated information about:
 - 2a. Amount of natural gas released.
 - 2b. Number of fatalities and injuries.
 - 2c. Significant facts relevant to the cause of the incident.
 - 2d. Extent of damages.

10.3.3 The 30-Day Report.

1. Within 30 days of confirmed discovery one of the following forms shall be filed with PHMSA : See [INCD 2](#) for forms and instructions
 - 1a. Form RSPA F 7100.1 Incident Report - Gas Distribution System,
or
 - 1b. Form RSPA F 7100.2 Incident Report - Gas Transmission and Gathering Systems
2. **If additional relevant information is obtained after submittal of the 30-day report, a supplemental report shall be submitted as deemed necessary. The supplemental report shall have a clear reference by date and subject to the original report.**

10.3.4 Retracting reports.

1. For 1-Hour Reports: PHMSA no longer requests operators to retract erroneously reported 1-Hour or 48 Hour NRC Notification Reports.
2. If the incident is subsequently determined to be caused by non-jurisdictional piping, an email should be sent to PHMSA Accident Investigation Division and ICC Pipeline Safety Office prior to the 30-day report requirement.
 - 2 a. The email should state that "AIC will not be submitting a 30-day report due to the event being determined to be caused by non- jurisdictional release of gas."
 - (i) The email should be sent to PHMSAAccidentInvestigationDivision@dot.gov, referencing the NRC notification number used for the initial report.
 - (ii) A copy of the email should be sent to the Assistant Director, Pipeline Safety, ICC and the Administrative Assistant, ICC Pipeline Safety.
3. For 30-Day Reports: If a report has been filed and further investigation reveals that the Natural Gas Incident was not an "incident" and therefore not reportable, Gas Compliance shall request that the report be retracted by contacting the PHMSA Informational Resources Manager by email at InformationResourcesManager@dot.gov. Requests are to include the following information:

- 3 a. The Report ID (the unique 8-digit identifier assigned by PHMSA).
- 3 b. Operator name.
- 3 c. PHMSA issued OPID number.
- 3 d. The number assigned by the National Response Center (NRC) when an immediate notice was made in accordance with §191.5. If Supplemental Reports were made to the NRC for the event, list all NRC Report numbers associated with the event.
- 3 e. Date of the event.
- 3 f. Location of the event.
- 3 g. A brief statement as to why the report should be retracted.
4. Also notify ICC and AIC's internal recipients, as appropriate, and include the brief statement about why the reports should be retracted.

10.4 Report a Natural Gas Incident to IDNR as follows:

10.4.1 The 24 Hour Report:

- The 24-Hour Report is based on the Potential Incident Report Form.
- Complete information is not necessary for the 24-Hour Report.
- Provide a 24-hour telephone number for where more detailed information can be obtained.
- Record a report number if provided by recipient.
- Record recipient's name plus date and time of contact.

1. The underground natural gas storage field where the release from the down-hole portion occurred.
2. The origin and extent of the release, including the name and location of the well.
3. The cause of the release.
4. Any corrective action taken by AIC to address the release or an explanation why corrective action was not taken.
5. Appropriate AIC internal notifications: See [Appendix D](#).

10.5 Annual Report on Service Interruptions:

10.5.1 A report of gas service interruptions that affect 25 or more customers for 8 hours or more shall be filed with the ICC Director of the Safety and Reliability Division and the Ameren Illinois Regulatory Affairs by April 1 with the following details for the previous year.

1. The number of service interruptions that:
 - 1 a. Lasted 8 hours or more but less than 12 hours.
 - 1 b. Lasted 12 hours or more.

UNCONTROLLED IF PRINTED

2. Dates of service interruptions that exceeded 8 hours in duration.
3. City and location of service interruptions that exceeded 8 hours in duration.
4. Reason for service interruptions that exceeded 8 hours in duration.

11.0 Post-Incident Alcohol and Drug Testing (49 CFR Part 199)

- 11.1 If the Potential Incident results from tasks performed by AIC personnel, drug and alcohol testing shall be administered within 2 hours for alcohol tests and 32 hours for drug tests.
- 11.2 Gas Superintendent / Gas Supervisor or Superintendent / Supervisor Gas Storage shall contact Supervisor Gas Control if Gas Control personnel could be subjected to alcohol or drug testing.
- 11.3 Appropriate Superintendent, Supervisor, and/or Supervisor Gas Control shall immediately contact Clinical Collection Management, Inc. (CCM) to arrange for alcohol and drug testing. See [Appendix D, Table 4](#) to arrange for testing.
- 11.4 An alcohol and drug test shall be administered at the earliest practical moment, but no later than 2 hours for the alcohol test and 32 hours for the drug test following an incident where:
- 11.4.1 Gas field personnel, storage field personnel, or Gas Control Specialist performance contributed to the incident or their performance cannot be completely discounted as a contributing factor to the incident.
 - 11.4.2 If the alcohol test is not administered within 2 hours following the incident, the appropriate Supervisor shall prepare and maintain a record stating the reasons the test was not promptly administered.
 - 11.4.3 If the alcohol test is not administered within 8 hours following the incident, the appropriate Supervisor shall cease attempts to administer an alcohol test and shall state in the record the reasons for not administering the test.

End of Instructions.

Operator Qualification (OQ) Required?

NO.

Appendices

[Appendix A - Gas Compliance Reporting Matrix](#)

[Appendix B - State and Federal Reporting Matrix](#)

[Appendix C - AIC, State and Federal Reporting Contacts](#)

[Appendix D - Ameren Corporate and AIC Internal Contacts](#)

[Appendix E - PHMSA Policy - Reporting Suspected Natural Gas Explosions](#)

Attachments

NONE.

Compliance Requirements

Title 83 Ch I ICC SubCh D 501.520: Interruptions of Service

Title 83 Ch I ICC SubCh D Part 590.10: Standards

UNCONTROLLED IF PRINTED

Title 83 Ch I ICC SubCh D Part 590.20: Submission of Federal Reports to Commission

Title 83 Ch I ICC SubCh D Part 595.110: Definitions

Title 83 Ch I ICC SubCh D Part 595.120: Reporting of Accidents or Incidents

Title 83 Ch I ICC SubCh D Part 595.130: Immediate Reports

IDNR 240.1805 Definitions

IDNR 240.1853 Reporting

20 ILCS 3305: Illinois Emergency Management Agency Act

49 CFR §191.3 Definitions.

49 CFR §191.5 Immediate notice of certain incidents.

49 CFR §191.7 Report submission requirements.

49 CFR §191.9 Distribution system incident report.

49 CFR §191.15 Transmission systems; gathering systems; liquefied natural gas facilities; and underground natural gas storage facilities: Incident report.

49 CFR §192.605 Procedural manual for operations, maintenance, and emergencies.

49 CFR Part 199 - Drug and Alcohol Testing

Reference Documents

[INCD 2 Incident Reporting: Forms and Reference Materials](#)

[INVE 3 Investigation of Incidents: Forms and Reference Materials](#)

Document Rescission

INCD 1 Incident Reporting – Requirements, December 1, 2022

Revision Notes

Location of Changes	Summary of Changes
Subsection 10.2	Formatting Correction - "Determine if the Potential Incident meets reporting criteria of:" should have been Subsection 10.2 but was missed during the Re-write.
Paragraph 10.3.3, Item 2.	Added reference to a Supplemental Report to the 30-day report
Appendix D	Added Table 5 - Integrated Operation Center (IOC) – AMI Readings with contact information to request AMI readings

Appendix A - Gas Compliance Reporting Matrix

Gas Compliance shall be contacted within 1 hour of confirmed discovery	
1	Death.
2	Personal injury requiring medical treatment or in-patient hospitalization.
3	Estimated property damage excluding cost of gas lost:
	a. \$25,000 or more for potential reporting to ICC or PHMSA
	b. \$25,000 or more for UNGSF potential reporting to IDNR.
4	Unintentional estimated gas loss of 3 million cubic feet or more.
5	An event that results in an emergency shutdown of an UNGSF.
6	An explosion.
7	Natural gas fueled fire with estimated property damage:
	a. \$25,000 or more for potential reporting to ICC or PHMSA or
	b. \$25,000 or more for UNGSF potential reporting to IDNR.
8	Damage to any high-pressure distribution or transmission line.
9	Damage to any distribution main with an estimated repair time in excess of 8 hours excluding gas service interruption relight time.
10	Gas service interruption to more than 400 meters.
11	Gas service interruption to 25 or more customers for durations of 8 hours or more.
12	Supply or pressure problems cause the Company to curtail firm (contract) load to more than 50 customers.
13	Unintentional estimated gas loss from the downhole portion of an UNGSF of 500,000 cubic feet or more that occurs within 1/8 mile of a dwelling used as a residence, place of business, or place of public assembly.

Appendix B - State and Federal Reporting Matrix

Report within 1 hour of confirmed discovery Exception: Report to IDNR is within 24 hours		ICC	IDNR (1)	IEMA	PHMSA
1	Death.	X	X		X
2	Personal injury requiring in-patient hospitalization.	X	X		X
3	Estimated property damage, excluding the cost of gas lost: \$129,300 or more per §191.3				X (2)
	\$50,000 or more	X	X		
4	Unintentional estimated gas loss of 3 million cubic feet or more.	X	X		X
5	An event that results in an emergency shutdown of an UNGSF.	X	X		X
6	An event that is significant in AIC's judgment, even though it did not meet the criteria of items 1 - 5 above.	X			X

UNCONTROLLED IF PRINTED

7	Gas service interruption to 50 or more meters for 12 hours or more.	X			
8	Gas service interruption to more than 400 meters.	X		X	
9	Supply or pressure problems cause AIC to curtail firm (contract) load to more than 50 customers.	X		X	
10	Any suspected natural gas explosion where it is initially unclear if a leak from AIC's facilities contributed to the explosion.	X			X
11	Unintentional estimated gas loss from downhole portion of an UNGSF of 500,000 cubic feet or more that occurs within 1/8 mile of a dwelling used as a residence, place of business, or place of public assembly.		X		

- (1) IDNR is notified when Natural Gas Incident involves a release of stored natural gas from the downhole portion of an UNGSF. That notification is required within a minimum of 24 hours.
- (2) The estimated property damage value threshold for PHMSA reporting will be adjusted each July 1, beginning July, 2022, for inflation in accordance with Appendix A of Part 191. PHMSA's adjusted value will be reflected in the next scheduled O&M Update.

Appendix C - AIC, State, and Federal Reporting Contacts

Table 1: Gas Compliance

Name	During Work Hours	Mobile	Home
John Bozarth	217-625-6854	217-257-6276	217-697-8495
Mark Popov	618-806-3726	618-806-3726	618-806-3726
Charles Rayot	217-625-6802	217-836-5133	217-483-4991
Aaron McElravy	217-663-3045	217-663-3045	217-663-3045

Table 2: ICC, IDNR, IEMA Contacts for Reporting

Agency	Title	Personnel	Office	Mobile
ICC	ICC Assistant Director, Pipeline Safety	Matt Smith		217-720-0291
ICC	After Hours Incident Reporting Number		217-782-5050	
IDNR	Acting Director	Dan Brennan	217-557-0664	
IEMA	Telecommunications Center		800-782-7860	

Table 3: Federal Contact Methods

Agency	24 Hour Telephone	Electronically
NRC	800.424.8802	http://www.nrc.uscg.mil
PHMSA		https://portal.phmsa.dot.gov/portal

Information Resources Manager	InformationResourcesManager@dot.gov
-------------------------------	--

Table 4: ICC Contacts for Reporting

ICC	Personnel	Office	Email
Director, Consumer Services Division	Jim Agnew	217-524-5048	James.Agnew@Illinois.gov
Director, Safety and Reliability Division	Eric Lounsberry	217-524-0337	Eric.Lounsberry@illinois.gov

Appendix D - Ameren Corporate and AIC Internal Contacts

Table 1: Corporate Claims

Name / Title	Phone Number	Cell Phone
Jackie French – Sr Dir, Ins Litigation & Claims	314-554-2223	
Tabitha Bono – Dir & Asst Gen Counsel Litigation & Claims	617-669-6875	618-340-4327
Nikki Jenkins – Claims Administrator	618-236-6285	Preferred 618-250-8616
Angela Case – Brentwood Services Liability Supervisor	800-781-2075	Preferred 636-812-9915

Table 2: Communications

Name	During Work Hours	Cell Phone
Stacey Stockton-Shangraw Northern (Divisions 1 & 2)	309-677-5073	309-242-4278
Brian Bretsch Southern (Divisions 5 & 6)	618-343-8087	618-407-6894
Marcelyn Love Central (Divisions 3 & 4)	618-301-5250	217-381-2241
After Hours: Weekdays: 05:00 PM to 08:00 AM and Weekends and Holidays		
CPR Duty Hot Line	309-863-5040	

Table 3: Regulatory Affairs

Name	During Work Hours	Cellular Phone Number
Brice Sheriff	217-535-5229	217-836-6395
Robin Turner	309-677-5422	309-696-7321

Table 4: Clinical Collection Management (CCM)

Name	During Work Hours	After Hours
Linda Gudorp	314-554-3307	314-779-5189
Jennifer Modesto	314-554-3272	
CCM	314-963-3404	800-619-1122

Table 5: Integrated Operation Center (IOC) - AMI Readings

UNCONTROLLED IF PRINTED

Name	During Work Hours	Cellular Phone Number
Technical Desk	855-904-2462	855-904-2462

Appendix E - PHMSA Policy: Reporting Suspected Natural Gas Explosions

During the first few hours following a house explosion, the source of the leaking gas is often unknown. Operators should promptly report these events telephonically to the NRC and state that the role of gas in the event is being investigated. Although NRC reports cannot be rescinded, they also do not count against an operator. PHMSA would prefer that operators make NRC reports for events that later prove to be non-jurisdictional than to not make NRC reports for events that later are determined to be jurisdictional.

In the days following a house explosion, the source of leaking gas is typically determined. If a leak on jurisdictional piping is determined to be the source of gas and an incident criterion has been met, the operator must also submit a 30-Day Report to PHMSA. If a leak on non-jurisdictional piping is determined to be the source of gas, the operator should not submit a 30-Day Report to PHMSA, unless the damage to the operator's property exceeds \$50,000. If the source of gas is still undetermined 30 days after the event, submit a report to PHMSA - it can be retracted, if necessary, after the source of gas has been determined. In summary, always call the NRC, but only report to PHMSA jurisdictional releases meeting the reporting criteria.

INCIDENT REPORTING

April 1, 2023

INCD 2 Forms and Reference Materials

Click on the links below to open the documents.

Forms

1. [PHMSA Incident Report - Gas Distribution System, Form F 7100.1, Rev. 4-2019](#)
2. [PHMSA Incident Report - Gas Transmission and Gathering Systems, Form F 7100.2, Rev. 4-2019](#)
3. [Potential Incident Report Form \(April 1, 2023\)](#)

These above forms and their instructions are available on [PHMSA's web site](#).

References

[Ameren Supervisor Guidelines for Drug and Alcohol Testing](#)

End of Section.

Document Rescission

INCD 2 Incident Reporting: Forms and Reference Materials, October 1, 2020.

Revision Notes

Location of Changes	Summary of Changes
Forms	Updated Potential Incident Report, added IOC contact information.

INVE-Investigation of Incidents

INVESTIGATION OF INCIDENTS

October 1, 2020

INVE 0 Table of Contents

[INVE 1 Investigation of Incidents: Requirements](#)

- Section 1.0 Purpose
- Section 2.0 Scope
- Section 3.0 Target Audience
- Section 4.0 General
- Section 5.0 NTSB investigation of Incident
- Operator Qualification (OQ)
- Compliance Requirements
- Reference Documents
- Document Rescission

[INVE 2.1 Investigation of Incidents: Incident Investigation](#)

- Section 1.0 Purpose
- Section 2.0 Scope
- Section 3.0 Target Audience
- Section 4.0 General
- Section 5.0 Incident Commander Responsibilities Documentation
- Section 6.0 Incident Commander Responsibilities Facility Investigation
- Section 7.0 Incident Commander Responsibilities Chain of Custody
- Section 8.0 Analysis of the Incident
- Section 9.0 Preservation of Evidence
- Section 10.0 NTSB Investigation of Incidents
- Operator Qualification (OQ)
- Compliance Requirements
- Reference Documents
- Document Rescission

[INVE 2.2 Investigation of Incidents: Investigation of Fires](#)

- Section 1.0 Purpose
- Section 2.0 Scope

UNCONTROLLED IF PRINTED

Section 3.0 Target Audience

Section 4.0 General

Section 5.0 Management of Fire, Ignition or Explosion Investigation

Section 6.0 Initial Assessment

Operator Qualification (OQ)

Compliance Requirements

Reference Documents

Document Rescission

INVE 2.3 Investigation of Incidents: Investigation of Failures

Section 1.0 Purpose

Section 2.0 Scope

Section 3.0 Target Audience

Section 4.0 General

Section 5.0 Analysis of Failed or Defective Materials

Operator Qualification (OQ)

Compliance Requirements

Reference Documents

Document Rescission

INVE 3 Investigation of Incidents: Forms and Reference Materials

Forms

Gas Incident Investigation Log

Chain of Custody Log

Failed Gas Material Form

Failed Gas Material Tag, Stock Code 1601631, Rev 06/18

References

NTSB Pipeline Investigation Guide (Wilson Ester 2019)

Document Rescission

End Table of Contents.

Document Rescission

INVE 0 Investigation of Incidents: Table of Contents, April 1, 2020.

Revision Notes

Location of Changes	Summary of Changes
Not applicable.	This is a new document.

UNCONTROLLED IF PRINTED

INVESTIGATION OF INCIDENTS

October 1, 2020

INVE 1 Requirements

1.0 Purpose

This document outlines Ameren Illinois (AIC) requirements for investigation of incidents in accordance with 49 CFR §192.617.

2.0 Scope

This document addresses the following:

[3.0 Target Audience](#)[4.0 General](#)[5.0 NTSB Investigation of Incident](#)**3.0 Target Audience**

- Gas Compliance Personnel
- Quality Assurance Personnel
- Gas Supervisors
- Gas Field Personnel
- Gas Tech Services (GTS) Supervisors
- Gas Tech Service (GTS) Personnel
- Gas Storage Field Supervisors
- Gas Storage Field Operators

4.0 General (49 CFR §192.617, Part 199)

4.1 AIC shall investigate potential incidents and reportable incidents (see [INCD 1](#) for descriptions) to determine if:

4.1.1 There was a failure in the gas system which caused or contributed to the incident.

4.1.2 Actions by members of the general public, natural disaster (e.g. lightning, flooding, storms, ground movement) or by an accident (i.e. vehicular crash, derailment or structure collapse) caused or contributed to the incident.

4.2 The incident investigation shall be:

4.2.1 Thorough.

4.2.2 Accurately and properly documented.

4.2.3 Confidential.

4.2.4 Inclusive of:

1. Pre-incident events (activities that may have contributed to the incident).
2. Concurrent-incident events (activities while the incident was happening).
3. Post-incident events (activities after the incident).

4.2.5 Focused on minimizing the possibility of recurrence. See [CNTS 1](#) and [INVE 2.3](#).

As used in the subparagraphs of [4.2.4](#), "activities" include actions by members of the general public, AIC customers, AIC personnel, and facilities, natural disasters and accidents).

4.3 AIC personnel shall:

- 4.3.1 Communicate and cooperate with emergency agencies and authorities having jurisdiction over the investigation (Authorities).
- 4.3.2 Secure the incident site and affected gas facilities to prevent tampering with evidence and exposing personnel to additional hazards until after the investigation is complete.
 - 1. Exceptions include:
 - 1 a. Authorities determine:
 - i.) Natural gas was not a contributing factor to the incident.
 - Or
 - ii.) Preserving the site and facilities would create a safety hazard to the general public.
 - 1 b. If Authorities determine natural gas is not a contributing factor to the incident, Ameren Claims shall determine if any evidence needs to be retained in AIC custody.
- 4.3.3 Inspect gas facilities, mains, and services in the vicinity to ensure they are safe, reliable, and unaffected by the incident. See [INVE 2.1](#).
- 4.3.4 For gas facilities that may have failed or may have been impacted, preserve and keep them in a secured location until Ameren Claims specifies a location where facilities can be analyzed.

5.0 NTSB Investigation of Incident

- 5.1 In the event that the National Transportation Safety Board (NTSB) is going to launch an investigation of the incident refer to [INVE 2.1 Section 10](#) NTSB Investigation of Incidents.

End of Instructions.

Operator Qualification (OQ) Required?

NO.

Appendices

NONE.

Attachments

NONE.

Compliance Requirements

49 CFR §192.617 Investigation of failures.

49 CFR Part 199 - Drug and Alcohol Testing

UNCONTROLLED IF PRINTED

Reference Documents

[CNTS 1 Continuing Surveillance: Requirements](#)

[INCD 1 Incident Reporting: Requirements](#)

[INVE 2.1 Investigation of Incidents: Incident Investigation](#)

[INVE 2.3 Investigation of Incidents: Investigation of Failures](#)

Document Rescission

INVE 1 Incident Investigation: Requirements, April 1, 2020.

Revision Notes

Location of Changes	Summary of Changes
Not applicable.	This is a new document.

INVESTIGATION OF INCIDENTS

October 1, 2022

INVE 2.1 Incident Investigation

1.0 Purpose

This document outlines Ameren Illinois (AIC) incident investigation procedures for determining the apparent cause of an incident and minimizing the possibility of a recurrence in accordance with 49 CFR §192.617.

2.0 Scope

This document addresses the following:

[3.0 Target Audience](#)**[4.0 General](#)****[5.0 Incident Commander Responsibilities - Documentation](#)****[6.0 Incident Commander Responsibilities - Facility Investigation](#)****[7.0 Incident Commander Responsibilities - Chain of Custody](#)****[8.0 Analysis of the Incident](#)****[9.0 Preservation of Evidence](#)****[10.0 NTSB Investigation of Incidents](#)****3.0 Target Audience**

- Gas Compliance Personnel.
- Quality Assurance Personnel
- Gas Supervisors
- Gas Field Personnel
- Gas Tech Services (GTS) Supervisors
- Gas Tech Services (GTS) Personnel
- Gas Storage Field Supervisors
- Gas Storage Field Operators
- Gas Control

4.0 General

4.1 The following actions should have been completed prior to beginning the investigation.

4.2.1 Emergency Plan (**[EMER 1](#)**) has been implemented and a hazardous condition no longer exists.

1. First responders (e.g., gas field personnel, gas supervisors) are on site and -
 - 1 a. Initially, giving the safety of the public and AIC customers and personnel top priority. Also coordinating with responding emergency agencies.
 - 1 b. Secondly, protecting property by dealing with affected facilities and making the area safe.

4.2.2 Incident Reporting (**[INCD 1](#)**) has been implemented.

4.2 An Incident Commander will be in control and coordinate the investigation. The Incident Commander should be an AIC management person and/or and Ameren Claims person.

4.3 AIC personnel shall cooperate with public officials, emergency response personnel, and regulatory authorities.

UNCONTROLLED IF PRINTED

- 4.4 AIC personnel shall courteously decline requests for information and investigation results by stating:
 - 4.4.1 *"The incident is under investigation, and official information will be provided through Ameren Illinois Communications when it becomes available"*.
 - 4.4.2 Requests for information shall be referred to Ameren Illinois Communications. See [INCD 1, Appendix D, Table 2](#).
 - 4.4.3 Requests for investigation results shall be referred to Ameren Legal & Claims. See [INCD 1, Appendix D, Table 1](#).
- 4.5 After the emergency has been resolved, AIC personnel -
 - 4.5.1 Shall notify Gas Standards & Procedures if a material failure or defect maybe involved in the incident. See [INVE 2.3](#).
 - 4.5.2 Shall implement:
 - 1. Sections [5.0](#) through 9.0.
UNLESS
 - 2. The National Transportation Safety Board (NTSB) notifies AIC that they will conduct the investigation. Then implement [Section 10.0](#).
- 4.6 Investigation of incidents related to fire or explosion is addressed in [INVE 2.2](#).

5.0 Incident Commander Responsibilities - Documentation

- 5.1 Limit the number of qualified gas field personnel and management required to perform the investigation.
 - 5.1.1 One person should be assigned to take photos and document the investigation. Warn all individuals not to record the scene by photograph and/or video.

Devices used to take photographs and/or videos, (i.e. cameras, cell phones, tablets) may be accessed as evidence.

- 5.1.2 Preserve the site.
 - 1. Do not disturb any materials or remove AIC facilities.
 - 2. Do not enter any structure associated with incident without permission or by request of public official having jurisdiction over scene.
- 5.1.3 If incident involves remotely monitored gas system or facility, contact Gas Control and request:
 - 1. A review of their data logs for any pertinent information.
 - 2. Flow and/or odorization information for the time of and around the incident.
- 5.1.4 Ensure that all information and evidence is accounted for in the Gas Incident Investigation Log. See [INVE 3](#).
- 5.1.5 Place high value on:
 - 1. Accurate and precise information.
 - 2. Report only facts not opinions.

3. Photographs of the investigation scene.
 4. Neat site drawings and sketches.
- 5.1.6 Record the sequence of events leading up to and throughout the incident.
1. Pre-incident events - activities that may have contributed to the incident
 2. Incident - activities while the incident was happening
 3. Post-incident events - activities following the incident
 4. Include information and data for Gas Control when applicable
- NOTE:** Activities are defined in [INVE 1 Subsection 4.2.4](#).
- 5.1.7 Create a photographic record of the investigation scene and note where photographs and/or videos were taken.
1. Pay special attention to areas which may include:
 - 1 a. Distribution of debris.
 - 1 b. Condition of exterior walls, roofs, and floors.
 - 1 c. Location of the explosion or fire.
 - 1 d. Condition of AIC equipment.
 - 1 e. Location of utilities and evidence of locates.
 - 1 f. Evidence of heat.
 - 1 g. Location of gas appliances and piping.
 - 1 h. Location of other combustibles.
 - 1 i. Consider any other areas of interest such as sewer traps, sewer clean-outs, etc.
- 5.1.8 Until Ameren Claims personnel arrive, process the witnesses.
1. Ensure that names, addresses, and phone numbers of all who witnessed the incident are recorded in the Gas Incident Investigation Log. Where applicable, include witness agency, title, and email address.
 2. Begin interviewing witnesses who may not be able to wait for the arrival of Ameren Claims personnel. Otherwise, consider having witnesses wait for Ameren Claims personnel.
- 5.1.9 Interview the witnesses by asking the questions below and recording their answers on "interview pages" in the Gas Incident Investigation Log.
1. Describe what happened including what was observed.
 2. Where were you when the incident took place?
 3. What time was it when the incident took place?
 4. What were you doing at the time of the incident?
- 5.1.10 Ensure that once on the scene, Ameren Claims personnel:
1. Are updated on status of the investigation.
 2. Reviews all of the documentation, photos and videos taken.

3. Takes custody of all photographs, videos, and documentation produced thus far.
 4. Finish processing witnesses.
 5. Coordinates the completion of the investigation.
- 5.1.11 Review the documents received and actions taken before continuing to Section 6.0.

6.0 Incident Commander Responsibilities - Facility Investigation

- 6.1 Ensure AIC facilities that may have been involved in the incident are investigated to verify proper operation.
- 6.2 Ensure a leak survey of the gas service and main is completed including sampling sewers, manholes and utility pedestals. See [LEAK 2.2](#).
- 6.3 Ensure AIC gas field personnel:
 - 6.3.1 Inspect gas meter sets to verify the meter sets -
 1. Have not been damaged by the incident,Or
 2. Are in danger of being damaged to the point of contributing fuel to the incident.
 - 6.3.2 *Before touching a gas meter set*, check the riser, meter and customer piping with a volt stick. See [METR 2.2 Section 7.0 paragraph 7.2.2](#).
 - 6.3.3 Write down the gas meter reading and meter number.
 - 6.3.4 Request remote automated meter readings, AMI, as soon as practical by contacting the Integrated Operation Center (IOC) Hotline at 835-904-2462, 24 hours per day / 7 days per week.
 - 6.3.5 Check condition of regulator for evidence of malfunctioning or tampering.
 - 6.3.6 Check condition of gas meter for damage or leakage.
 - 6.3.7 Check meter valve for possible heat damage that would allow gas to leak by the meter valve.
 - 6.3.8 Check riser for PE service that could be damaged by the heat.
- 6.4 Ensure odorant level of the gas is checked by qualified AIC gas field personnel using an approved odorator. See [ODOR 3](#) for manufacturer's instructions.
 - 6.4.1 In addition to the reading performed by AIC personnel, request that a public official, (i.e. police or fire department personnel), check the readily detectable odorant level.
 - 6.4.2 Perform a reading upstream and downstream of the incident and as close to the incident as possible.
- 6.5 Ensure multiple samples of natural gas, air, and materials are collected and marked for identification.
- 6.6 Ensure delivery pressure and lock up pressure of the service regulator are checked. See [TURN 2.1](#).
- 6.7 Test the gas service at operating pressure if required by the local agency, state, or federal authorities.

6.8 Ensure AIC facilities are:

6.8.1 Removed only after receiving approvals from the incident investigating team, including:

- AIC Gas Compliance
- State Fire Marshal
- Illinois Department of Natural Resources
- Illinois Commerce Commission
- Ameren Claims

6.8.2 Tagged and secured as evidence.

6.9 Ensure the transfer of custody of the evidence is documented on the Chain of Custody Log. See [INVE 3](#).

7.0 Incident Commander Responsibilities - Chain of Custody

7.1 The Incident Commander shall ensure the following:

7.1.1 AIC personnel document the chain of custody for all removed facilities that may have been involved in the incident.

7.1.2 If there is reason to believe that an individual's performance of a covered task contributed to the incident,

1. Any and all tools and equipment involved in the performance of the covered task shall be removed from service.
2. The transfer of custody shall be documented. See Paragraph 7.1.3.

7.1.3 Facilities, tools, and equipment removed from service shall be tagged using Chain of Custody Tag. See [INVE 3](#).

7.1.4 The transfer of custody shall be documented on the Chain of Custody Tag and on the Chain of Custody Log. See [INVE 3](#).

8.0 Analysis of the Incident

8.1 AIC Claims and AIC management personnel shall review the information collected during the initial investigation.

8.2 The Incident Commander shall:

8.2.1 Convene a meeting including:

1. AIC gas field personnel involved in the field investigation.
2. AIC Supervisors.
3. Ameren Risk Management.
4. Ameren Legal & Claims representatives.
5. Gas Standards & Procedures if a material failure or defect is involved.
6. Gas Control personnel if they provided any information.

8.2.2 Review all actions taken and documents collected.

8.2.3 Determine what additional information needs to be obtained.

8.2.4 Determine what additional interviews need to be completed.

8.2.5 Determine what additional AIC records may be needed.

UNCONTROLLED IF PRINTED

- 8.2.6 Review emergency response agency reports.
- 8.2.7 Determine if an outside specialist is needed to conduct further investigations.
- 8.2.8 Develop a summary of the events that led up to, through, and after the incident.

8.3 The final report shall:

- 8.3.1 Outline the facts that led up to, through, and after the incident.
- 8.3.2 Contain supporting documentation.
- 8.3.3 Establish the apparent cause of the incident.
- 8.3.4 Propose steps to minimize the possibility of recurrence.

9.0 Preservation of Evidence

- 9.1 AIC Gas Compliance and Ameren Legal & Claims shall prescribe preservation protocols for information collected through the investigation and analysis of the incident.
- 9.2 Documents shall be numbered and filed.
- 9.3 Facilities removed shall be tagged and stored in a secure location for a minimum of 5 years unless Ameren Legal provides written notification that the facilities may be disposed of or placed back into service.
- 9.4 Tools and equipment removed from service shall be tagged and stored in a secure location until the investigation is complete.
 - 9.4.1 Equipment such as a trencher, backhoe, or directional boring machine may be secured at the Operating Center (OC) by removing the ignition key and being tagged "Out of Service".
 - 9.4.2 Tools and equipment may be placed back in service once the investigation is complete and the Ameren Legal Department provides written notification that the tools or equipment may be placed back into service.
- 9.5 Once the facilities, tools, and equipment are disposed of or placed back into service, the chain of custody documentation shall be placed in the incident investigation file.

10.0 NTSB Investigation of Incidents

Section 10.0 provides an overview of instructions and guidance to AIC personnel if the National Transportation Safety Board (NTSB) launches an investigation of an incident. See [INVE 3](#) NTSB Pipeline Investigation Guide for specific details.

- 10.1 NTSB takes complete control of investigation.
- 10.2 Prior to the arrival of or communication with the NTSB Investigator-in-Charge, affirmative investigative activity shall be limited to excavation, testing, etc. that:
 - 10.2.1 Cannot wait.
 - 10.2.2 Is intended to mitigate the hazard.
 - 10.2.3 Preserves life and property.
- 10.3 NTSB Party Members include:

10.3.1 Ameren Party Coordinator (APC) and Alternate.

1. The APC shall:
 - 1 a. Manage the disclosure of information and documentation to NTSB.
 - 1 b. Serve as the face of AIC in all NTSB interactions.

All information shared with NTSB may become public information.

2. APC and Alternate shall be:
 - 2 a. AIC personnel who are not attorneys.
 - 2 b. Trained in the procedural and substantive aspects of NTSB investigations.

10.3.2 APC Assistant.

1. AIC personnel who assists APC in taking notes and collecting data requested by NTSB.

End of Instructions.

Operator Qualification (OQ) Required?

YES

1371 Operate Gas Pipeline – System Control Center Operations

1381 Operate Gas Pipeline – Local Facility Remote Control Operations

Appendices

NONE.

Attachments

NONE.

Compliance Requirements

49 CFR §192.617 Investigation of failures.

Reference Documents

[EMER 1 Emergency Plan: Requirements](#)

[INCD 1 Incident Reporting: Requirements](#)

[INVE 3 Investigation of Incidents: Forms and Reference Materials](#)

[LEAK 2.2 Leak Management: Outdoor Leak Investigation](#)

[METR 2.2 Metering: Meter Inspection and Testing - Field](#)

[TURN 2.1 Turn-on Turn-off: Residential/Small Commercial Customer](#)

Document Rescission

INVE 2.1 Investigation of Incidents: Incident Investigations, October 1, 2021.

UNCONTROLLED IF PRINTED

Revision Notes

Location of Changes	Summary of Changes
Paragraph 6.3.4	Added the contact information for requesting the remote automated meter reading, AMI, from the Integrated Operations Center (IOC) 24 hours/day / 7 days per week,

INVESTIGATION OF INCIDENTS

October 1, 2020

INVE 2.2 Investigation of Fires

1.0 Purpose

This document outlines Ameren Illinois (AIC) procedures for investigating the apparent cause of gas related fires, ignitions, and explosions in accordance with 49 CFR §192.617.

2.0 Scope

This document addresses the following:

[3.0 Target Audience](#)[4.0 General](#)[5.0 Management of Fire, Ignition, or Explosion Investigation](#)[6.0 Initial Assessment](#)**3.0 Target Audience**

- Gas Compliance Personnel.
- Quality Assurance Personnel
- Gas Supervisors.
- Gas Field Personnel
- Gas Tech Services (GTS) Supervisors
- Gas Tech Services (GTS) Personnel.
- Gas Storage Field Supervisors
- Gas Storage Field Operators

4.0 General

4.1 The following actions should have been completed prior to beginning the investigation.

4.1.1 The appropriate Emergency Plan has been implemented and a hazardous condition no longer exists.

4.1.2 Incident Reporting ([INCD 1](#)) has been implemented.

4.2 An AIC management personnel will serve as AIC's Incident Commander to coordinate AIC's investigation and AIC's interaction with the scene's Unified Commander. See [Subsection 5.1](#).

4.3 The presence of the media, general public, and AIC customers at fires, ignitions, and explosion is common.

4.3.1 AIC personnel shall:

1. Courteously decline any requests for information by stating:

"The incident is under investigation, and official information will be provided through Ameren Illinois Communications when it becomes available".

2. Refer all requests for information to Ameren Illinois Communications. See [IN-CD 1, Appendix D, Table 2](#).

4.3.2 Press releases shall be coordinated with the Incident Command System protocol.

4.4 Once determined that natural gas is suspected or confirmed to have been involved in the incident, AIC's personnel shall limit discussions with the Incident Commander / fire

UNCONTROLLED IF PRINTED

department to a designated AIC individual while continuing to cooperate to make the scene safe for the fire department, general public, and AIC customers.

- 4.4.1 Any requests for investigation results should be directed to Ameren Legal & Claims.
- 4.4.2 AIC's Incident Commander will designate an individual to maintain a log of the investigation documenting the actions taken and evidence gathered. See [INVE 2.1](#).
- 4.4.3 The content of the investigation should remain confidential and should not be released to anyone external to AIC without approval from Ameren Legal & Claims.

5.0 Management of Fire, Ignition, or Explosion Investigation

- 5.1 The scene may be under the jurisdiction of an outside authority. AIC Incident Commander should communicate and cooperate with that authority.

6.0 Initial Assessment

- 6.1 AIC gas field personnel shall look for any indications that natural gas may have been involved including:
 - 6.1.1 Reports of an explosion or loud noise.
 - 6.1.2 Smell of gas before the fire.
 - 6.1.3 Windows that are blown out.
 - 6.1.4 Walls that have collapsed outward.
 - 6.1.5 Roof that has shifted.
 - 6.1.6 Burns or charring near gas appliances and piping.
- 6.2 The AIC gas field personnel shall attempt to talk with the Incident Commander, Fire Marshal, Fire Department, or other investigating authority at the scene to determine if they have identified the probable cause of the fire.
 - 6.2.1 If the information received indicates that *natural gas was not involved* in the cause of the fire, no further investigation is required. The AIC gas field personnel shall notify Gas Supervisor that they responded to a fire that did not involve natural gas.
 - 6.2.2 If the information received indicates that *natural gas could be or is involved*, the gas field personnel shall immediately contact Gas Supervisor.
- 6.3 Once the determination has been made that AIC gas facilities could be or are involved in a fire, the investigation activities shall be performed in accordance with [INVE 2.1](#).

End of Instructions.

Operator Qualification (OQ) Required?

NO.

Appendices

NONE.

Attachments

NONE.

UNCONTROLLED IF PRINTED

Compliance Requirements

49 CFR §192.617 Investigation of failures.

Reference Documents

[EMER 2.4.5 Emergency Plan: Dispatched to Gas Related Fire, Ignition, or Explosion](#)

[EMER 2.4.6 Emergency Plan: Dispatched to Non-Gas Related Fire, Ignition, or Explosion](#)

[EMER 2.4.7 Emergency Plan: Dispatched to Explosion and/or Fire Near Gas Pipeline Facilities](#)

[INCD 1 Incident Reporting: Requirements](#)

[INVE 2.1 Investigation of Incidents: Incident Investigation](#)

Document Rescission

INVE 2.02 Investigation of Incidents: Investigation of Fires, April 1, 2020.

Revision Notes

Location of Changes	Summary of Changes
Not applicable.	This is a new document.

INVESTIGATION OF INCIDENTS

October 1, 2022

INVE 2.3 Investigation of Failures

1.0 Purpose

This document outlines Ameren Illinois (AIC) procedures for investigating failed facilities or equipment that may have caused an emergency in accordance with 49 CFR §192.617.

2.0 Scope

This document addresses the following:

[3.0 Target Audience](#)**[4.0 General](#)****[5.0 Analysis of Failed or Defective Materials](#)****3.0 Target Audience**

- Gas Compliance Personnel
- Quality Assurance Personnel
- Gas Supervisors
- Gas field personnel.
- Gas Tech Services (GTS) Supervisors
- Gas Tech Services (GTS) Personnel
- Gas Storage Field Supervisors
- Gas Storage Field Operators

4.0 General**4.1 Gas Standards & Procedures shall -**

- 4.1.1 Ensure failed facilities and equipment are analyzed to determine the root cause of the failure.
- 4.1.2 Work with the Integrity Management personnel to determine what actions should be taken to minimize the possibility of a recurrence.

4.2 Guidelines for analysis of failed or defective materials.

- 4.2.1 All failed or defective materials found or reported in AIC gas transmission, distribution systems or gas storage field facilities shall be fully analyzed and documented.
- 4.2.2 Gas Standards & Procedures is to be notified of a material failure or defect. An analysis will be initiated to determine the cause of the problem and to develop preventive or corrective measures.
- 4.2.3 The failed or defective material is often sent to a third party testing facility or to the manufacturer for testing and analysis.

By collecting and inspecting failed materials at a central location, the potential impact of the failures can be assessed, interim information communicated to operations, and system-wide decisions can be made concerning need to take preventive measures.

- 4.2.4 Gas Standards & Procedures will coordinate the analysis for the following situations:
1. Failure due to defective materials or components.
 2. Failure due to incorrect use of a component.
 3. Failure occurring during installation of a component.
 4. Failure occurring while the component is in service.
 5. Components suspected of being defective before use.
 6. Incorrect part or material supplied by the manufacturer.
- 4.2.5 In the following situations, it will not be necessary to perform a failure analysis:
1. Pipe that was damaged by a third party.
 2. Corroded pipe.
 3. Leaks due to loosely threaded fittings.
 4. Known material/component with an established corrective policy, such as DuPont Aldyl-A- and Plexco tapping tee caps, compression couplings, tees, valves, or the Mueller inner-lock meter valves.

5.0 Analysis of Failed or Defective Materials

- 5.1 If the failure warrants an analysis according to the guidelines outlined above, an e-mail with an attached completed Failed Gas Material Form (see [INVE 3](#)) shall be sent to Gas Standards & Procedures, ILGasStandards@ameren.com, as soon as possible.
- 5.2 Include a detailed description of the circumstances surrounding the failure on the completed form.
- 5.3 A Failed Gas Material Tag (see [INVE 3](#)) should be affixed to the failed material item and the item should be sent to the Gas Standards & Procedures, 10 Executive Drive, Collinsville, IL 62234 for analysis, if practical.
- 5.3.1 Material items that cannot be shipped should be retained at the local office. Arrangement will be made to pick-up the material.
- 5.3.2 The unique tag number should be included in the e-mail notification for reference.
- 5.4 After being notified of a failed or defective material item, Gas Standards & Procedures will:
- 5.4.1 Promptly notify the Gas Standards Committee and other areas of AIC about failure to ensure all Operating Centers are alert to the possibility that similar failures may occur.
- 5.4.2 Conduct a thorough investigation to determine the root cause of the problem. The investigation may include lab analysis and research with vendors, other gas utilities, and/or industry associations.
- 5.4.3 Notify Integrity Management about the failure and the subsequent results of the analysis.
- 5.4.4 Notify the Gas Standards Committee and Gas Superintendents about the results of the analysis and provide recommendations for actions to alleviate the problem on a system-wide basis.

5.4.5 Determine whether the material will be removed from the Ameren material catalog in EMPRV.

1. If a stock item is to be removed from the material catalog, Gas Standards shall determine an alternative material to replace the material removed.
2. Changes to the material catalog shall be communicated to the Gas Superintendents and appropriate field operating personnel.

End of Instructions.

Operator Qualification (OQ) Required?

NO.

Appendices

NONE.

Attachments

NONE.

Compliance Requirements

49 CFR §192.617 Investigation of failures.

Reference Documents

[EMER 3 Emergency Plan: Forms and Reference Materials](#)

Document Rescission

INVE 2.1 Investigation of Incidents – Incident Investigations, October 1, 2021

Revision Notes

Location of Changes	Summary of Changes
Paragraph 6.3.4	Added the contact information for requesting the remote automated meter reading, AMI, from the Integrated Operations Center (IOC) 24 hours/day / 7 days per week.

INVESTIGATION OF INCIDENTS

October 1, 2022

INVE 3 Forms and Reference Materials

Click on the links below to open the documents.

Forms

1. [Gas Incident Investigation Log](#) Updated
2. [Chain of Custody Log](#)
3. [Failed Gas Material Form](#)
4. [Failed Gas Material Tag, Stock Code 1601631, Rev 02/22](#) Updated

References

1. [NTSB Pipeline Investigation Guide \(Wilson Elser 2019\)](#)

End of Section.

Document Rescission

INVE 3 Investigation of Incidents – Forms and Reference Materials, October 1, 2020

Revision Notes

Location of Changes	Summary of Changes
Forms	Updated: Gas Incident Investigation Log Failed Gas Materials Tag

LEAK-Leak Management

LEAK MANAGEMENT

April 1, 2023

LEAK 0 Table of Contents

[LEAK 1 Leak Management: Requirements](#)

Section 1.0 Purpose

Section 2.0 Scope

Section 3.0 Target Audience

Section 4.0 Leak Investigations General

Section 5.0 Leak Detection and Classification

Section 6.0 Transmission Leak Surveys

Section 7.0 Distribution Leak Surveys

Section 8.0 Upgrading a Leak

Section 9.0 Foreign Gas

Section 10.0 Leak Surveillance, Repair, and Reevaluation

Section 11.0 Multiple Public Leak Call

Section 12.0 Recheck of Repaired Leak

Section 13.0 Leak Response Time

Section 14.0 Records

Operator Qualification (OQ)

Appendices

Appendix A - Conversion Chart Natural Gas Readings

Appendix B - Leak Process Flow Charts

Compliance Requirements

Reference Documents

Document Rescission

[LEAK 2.1 Leak Management: Indoor Investigations](#)

Section 1.0 Purpose

Section 2.0 Scope

Section 3.0 Target Audience

Section 4.0 General

Section 5.0 Upon Arrival

UNCONTROLLED IF PRINTED

Section 6.0 Approaching Structure

Section 7.0 Customer Home

Section 8.0 Customer Not Home or Structure Inaccessible

Section 9.0 Leak on Customer Facility

Section 10.0 Records

Operator Qualification (OQ)

Appendices

Appendix A - Screen Views of OAS 62, 63, 65, 6F, and 6H

Compliance Requirements

Reference Documents

Document Rescission

LEAK 2.2 Leak Management: Outside Investigations

Section 1.0 Purpose

Section 2.0 Scope

Section 3.0 Target Audience

Section 4.0 General

Section 5.0 Upon Arrival

Section 6.0 Above Grade Gas Facilities

Section 7.0 Below Grade Gas Facilities

Section 8.0 Classifying Outdoor Leaks

Section 9.0 Hazardous Conditions

Section 10.0 Leaks on Customer-Owned Facilities

Section 11.0 Records

Operator Qualification (OQ)

Compliance Requirements

Reference Documents

Document Rescission

LEAK 2.3 Leak Management: Leak Investigation Form

Section 1.0 Purpose

Section 2.0 Scope

Section 3.0 Target Audience

Section 4.0 General Information

Section 5.0 Indoor Leak Investigation Record

Section 6.0 Outdoor Leak Investigation Record

Section 7.0 Back-Page Information

UNCONTROLLED IF PRINTED

Section 8.0 Records Retention

Section 9.0 Gas Leak Investigation Form

Operator Qualification (OQ)

Appendices

Appendix A - Gas Leak Investigation Form

Compliance Requirements

Reference Documents

Document Rescission

LEAK 2.4 Leak Management: Leak Surveys

Section 1.0 Purpose

Section 2.0 Scope

Section 3.0 Target Audience

Section 4.0 Transmission Lines

Section 5.0 High-Pressure Distribution Mains and Services

Section 6.0 Business Districts

Section 7.0 Yardlines

Section 8.0 Inside Meter Sets

Section 9.0 Unprotected Steel Lines

Section 10.0 Common Survey Actions and Considerations

Section 11.0 Inaccessible Gas Facilities

Operator Qualification (OQ)

Compliance Requirements

Reference Documents

Document Rescission

LEAK 2.5 Leak Management: Leak Detection Equipment

Section 1.0 Purpose

Section 2.0 Scope

Section 3.0 Target Audience

Section 4.0 General

Section 5.0 Portable Flame Ionization Instrument

Section 6.0 Combustible Gas Indicator (CGI)

Section 7.0 Gas Detection Instrument

Section 8.0 Mobile Flame Ionization Unit (FI)

Section 9.0 Remote Methane Detector (RMD)

Section 10.0 – Laser Spectroscopy - Advanced Mobile Leak Detection (AMLD)

UNCONTROLLED IF PRINTED

Section 11.0 Records

Operator Qualification (OQ)

Compliance Requirements

Reference Documents

Document Rescission

LEAK 2.6 Leak Management: Walking Leak Surveys

Section 1.0 Purpose

Section 2.0 Scope

Section 3.0 Target Audience

Section 4.0 General

Section 5.0 Instrument Use

Section 6.0 Survey Routing

Section 7.0 Surveying Service Lines

Section 8.0 Outside Meter Set, Farm Tap, Regulator Station

Section 9.0 Fenced Facilities

Section 10.0 Inaccessible Facilities

Section 11.0 Weather Limitations

Section 12.0 Leak Detection- Using Gas Detection or FI Unit

Section 13.0 Remote Methane Leak Detector (RMLD) Survey

Operator Qualification (OQ)

Compliance Requirements

Reference Documents

Document Rescission

LEAK 2.7 Leak Management: Mobile Leak Surveys

Section 1.0 Purpose

Section 2.0 Scope

Section 3.0 Target Audience

Section 4.0 General

Section 5.0 Mobile Flame Ionization (FI) Leak Survey

Section 6.0 Weather Limitations

Section 7.0 Leak Detection

Section 8.0 Remote Methane Leak Detector (RMLD) Survey

Section 9.0 Optical Methane Detector (OMD) Survey

Operator Qualification (OQ)

Compliance Requirements

UNCONTROLLED IF PRINTED

Reference Documents

Document Rescission

LEAK 2.8 Leak Management: Advanced Mobile Leak Survey

Section 1.0 – Purpose

Section 2.0 -- Scope

Section 3.0 – Target Audience

Section 4.0 – General

Section 5.0 – Data Collection Driving Protocol

Section 6.0 – Indication Investigation

Section 7.0 – Gap Survey

Operator Qualification (OQ)

Compliance Requirements

Reference Documents

Document Rescission

LEAK 2.9 Leak Management: Survey Maps and Records

Section 1.0 Purpose

Section 2.0 Scope

Section 3.0 Target Audience

Section 4.0 General

Section 5.0 Maps and Records

Operator Qualification (OQ)

Compliance Requirements

Reference Documents

Document Rescission

LEAK 3 Leak Management: Forms and Reference Materials

Forms

References

Document Rescission

End Table of Contents

Document Rescission

LEAK 0 Leak Management – Table of Contents, October 1, 2022

Revision Notes

Location of Changes	Summary of Changes
---------------------	--------------------

UNCONTROLLED IF PRINTED

LEAK 2.5	Title changed – Leak Detection Equipment
LEAK 2.5	Removed: Gas-Trac section, Optical Methane Detector (OMD) section. Renamed: Remote Methane Detector (RMD section Corrected Section name: Laser Spectroscopy – Advanced Mobile Leak Detection (AMLD)

LEAK MANAGEMENT

April 1, 2023

LEAK 1 Requirements

1.0 Purpose

This document describes requirements for Ameren Illinois (AIC) to ensure that all natural-gas leakage is investigated, classified, monitored, repaired, and reported in accordance with applicable federal / state regulations.

2.0 Scope

This document addresses the following:

[3.0 Target Audience](#)[4.0 Leak Investigations - General](#)[5.0 Leak Detection and Classification](#)[6.0 Transmission Leak Surveys](#)[7.0 Distribution Leak Surveys](#)[8.0 Upgrading a Leak](#)[9.0 Foreign Gas](#)[10.0 Leak Surveillance, Repair, and Reevaluation](#)[11.0 Multiple Public Leak Calls](#)[12.0 Recheck of Repaired Leak](#)[13.0 Leak Response Time](#)[14.0 Records](#)

Appendices:

[Appendix A - Conversion Chart - Natural Gas Readings](#)[Appendix B - Leak Process Flow Charts](#)**3.0 Target Audience**

- Gas Field Personnel.
- Gas Supervisors.
- Gas Tech Services Personnel.
- Gas Tech Services Supervisors.

4.0 Leak Investigations - General

- 4.1 Transmission lines, gas mains, and services must be maintained to operate in a safe and reliable manner. Any leak that impairs system serviceability and reliability must be investigated and repaired in accordance with applicable procedures and methods contained in the O&M Plan. See [REPR 1](#).
- 4.2 AIC will respond to all leak or odor complaints in a timely / priority manner and complete a thorough investigation to ensure public safety.
- 4.3 If the initial investigation determines AIC is not the licensed gas distribution company for the area and does not have gas facilities in the vicinity, the gas personnel shall:

UNCONTROLLED IF PRINTED

- 4.3.1 Check for hazardous condition.
- 4.3.2 If hazardous condition exists, take appropriate action to protect the public and property, such as:
 - 1. Shutting off gas meter valve.
 - 2. Evacuating the structure.
 - 3. Notifying Police or Fire Department.
- 4.3.3 Notify Gas Dispatch that the leak is from a non-AIC facility.
- 4.3.4 Notify and update the Company or organization that provides the gas service of the situation.
 - 1. Gas Dispatcher may have contact information, or
 - 2. Contact local emergency agencies.

Unless a hazardous condition exists, gas personnel do not need to wait for the appropriate Company or organization to arrive.

- 4.3.5 Enter actions taken on the OAS order.
- 4.4 Qualified personnel must follow detailed procedures for investigation of indoor and outdoor gas leak complaints.
- 4.5 While performing a gas leak investigation at the customer premise, gas field personnel should use their nose to sniff test the gas to ensure odorant is readily detectable and document it. See **LEAK 2.3, Paragraphs 5.6.1** and **6.4.1** for documenting a sniff test.
- 4.6 An identified hazardous condition may require implementation of the AIC Emergency Plan.
- 4.7 Leak investigations must be properly documented and reported.
- 4.8 AIC will investigate / report any gas odor call, received through the Customer Service Center, where response time exceeds 60 minutes.

5.0 Leak Detection and Classification

- 5.1 Identified gas leaks must be evaluated and classified based on:
 - 5.1.1 Location,
 - 5.1.2 Hazard potential, and
 - 5.1.3 Measured volume of gas-in-air (reference sustained reading with Combustible Gas Indicator (CGI)).
- 5.2 Leak measuring requirements are as follows:
 - 5.2.1 **Below grade:** Use CGI test instrument (designed to register % gas-in-air), calibrated according to manufacturer instructions.
 - 5.2.2 **Above grade:** See [Appendix B](#) for Leak Process Flow Chart.
 - 5.2.3 **Water area:** Area covered or saturated by water, where bubbles are an indicator of a leak, should use the following procedure:
 - 1. Determine if the leak is blowing or bubbling.

2. If gas is blowing, classify leak Class 1 and handle appropriately.
3. If gas is bubbling, assume entire area underwater has a reading of 100% gas since CGI cannot obtain a gas reading underwater.
 - 3 a. Zero out the gas leak in a minimum of four directions and classify accordingly.
 - Leak migration must be checked by doing a thorough leak investigation following the procedures outlined in [LEAK 2.2, Section 7.0](#), Below-Grade Gas Facilities.
 - 3 b. If leak cannot be zeroed out in a minimum of four directions, leak shall be classified as Class 1 and handled appropriately.
- 5.3 Leaks shall be evaluated based on natural gas being sampled under stabilized conditions.
- 5.4 Classification shall only be made by qualified gas field personnel and/or qualified Gas Supervisor.
- 5.5 Leak classes establish repair priority and action criteria:
 - 5.5.1 **Class 1 leak:** Existing or probable hazard to property and general public, which requires continuous monitoring and immediate repair or action to eliminate hazardous condition.
 - 5.5.2 **Class 2 leak:** Not immediate hazard to property or general public but has potential of becoming a hazard; must be resurveyed *every 6 months* and *repaired within 1 calendar year* (no later than 15 months from leak report date).
 - 5.5.3 **Class 3 leak:** Non-hazardous and expected to remain non-hazardous; requires *reevaluation at next survey* (no later than 15 months from leak report date) to ensure leak remains non-hazardous.
- 5.6 Leak class determination and the required surveillance must be properly documented.

1. Gas leaks on customer facilities are not to be classified.
2. Gas leaks (above or below grade) on AIC facilities shall be classified and documented in ClickMobile.

- 5.7 If gas concentration is detectible on a CGI, but sustained reading is 2% LEL or less, this is not a reportable reading and considered no leak. However, if the reading is within 5 feet of a foundation wall, additional investigation measures may include:

See [Appendix A](#) for natural gas conversion chart.

- 5.7.1 Recheck the reading with a different CGI to verify 0% LEL reading, or
- 5.7.2 Physically dig up the service at the foundation wall and visually inspect for possible leak.
- 5.8 Any leak indication on a regulator station relief valve should be reported to Gas Tech Services as soon as possible.

- 5.9 Leaks identified on AIC facilities during routine work activities shall follow the same classification procedures outlined in this procedure.

6.0 Transmission Leak Surveys (49 CFR §192.706)

- 6.1 Transmission lines are required to be surveyed annually (not to exceed 15 months) using leak detection equipment. If located in Class 3 or Class 4 location, the required interval is as follows:
- 6.1.1 **Class 3 location:** Survey 2 times each calendar year (not to exceed 7-1/2 months).
- 6.1.2 **Class 4 location:** Survey 4 times each calendar year (not to exceed 4-1/2 months).

AIC does not have any transmission lines in Class 4 locations.

7.0 Distribution Leak Surveys (49 CFR §192.723)

- 7.1 Leak surveys are required using appropriate leak detection equipment as follows:
- 7.1.1 Cathodically protected gas facilities located *outside of Business Districts*: every 4 years (not to exceed 51 months).
- 7.1.2 Distribution mains and services located *within Business Districts*: once each calendar year (not to exceed 15 months).
- 7.1.3 Inside gas meters located *outside Business Districts*: once every 4 years (not to exceed 51 months).
- 7.1.4 Cathodically unprotected distribution lines at least once every 3 calendar years not to exceed 39 months.
- 7.2 Residential "yardlines" are customer-owned, primary underground gas lines where meter is located more than 3 feet from the outside wall of the served structure. Yard lines to be leak surveyed every 3 calendar years (not to exceed 39 months).

8.0 Upgrading a Leak

- 8.1 At the discretion of the qualified gas field personnel at the scene, a leak may be upgraded to Class 1 or Class 2.
- 8.2 Some of the factors which should be considered when upgrading a leak are:
- 8.2.1 Frozen ground.
- 8.2.2 Concrete or asphalted surface.
- 8.2.3 Heavily traveled areas.
- 8.2.4 Public buildings.
- 8.2.5 Conditions which may affect the migration of gas.

9.0 Foreign Gas

- 9.1 Combustible gases, other than those from AIC facilities, are not required to be classified. These might include:
- 9.1.1 Gasoline.

- 9.1.2 Sewer gas.
- 9.1.3 Swamp gas.
- 9.1.4 Methane from other decomposing material.
- 9.1.5 Natural gas from another supplier or utility.

9.2 An ethane identifier should be used to verify that the foreign gas is not natural gas. See [LEAK 3](#) for the reference material on ethane identifier.

10.0 Leak Surveillance, Repair, and Reevaluation (49 CFR §192.613)

- 10.1 Surveillance must be performed by qualified gas field personnel.
- 10.2 Surveillance information, including sketches, should be compared to previously performed surveillance to determine if there has been any significant change.
- 10.3 *Class 1*: Requires immediate repair or continuous action until the hazardous condition no longer exists.
 - 10.3.1 Venting may be employed to protect the public and property; however, the leak remains Class 1 leak until approved repairs are completed.
 - 10.3.2 Leak repairs on compression fittings must follow [REPR 2.1 - Section 5.0](#).
 - 10.3.3 Additional actions may be employed to eliminate the hazardous condition, with Director approval. The leak remains a Class 1 leak.
 - 1. After additional actions are completed, verify the hazardous condition no longer exists.
 - 2. Monitor daily until permanent repairs are made.
 - 3. Document approval and actions taken and attach documentation to the leak in Maximo.
- 10.4 *Class 2*:
 - 10.4.1 Surveillance shall be performed once *every 6 months* using CGI.
 - 1. If surveillance indicates no leak, additional surveillance shall be performed *within 6 months* to verify leak no longer exists.
 - 10.4.2 Repair: Class 2 leak shall be repaired *within 1 year* (not to exceed 15 months).
- 10.5 *Class 3*:
 - 10.5.1 Reevaluate during *next scheduled survey*, but within 15 months.
 - 10.5.2 Surveillance of below-grade leaks must be performed using a CGI and bar holes.
 - 10.5.3 Surveillance of above-grade leaks can be performed using leak detection fluid or leak detection instrument.
 - 10.5.4 If leak surveillance indicates no leak, an additional surveillance shall be performed *within 6 months* to verify the leak no longer exists.
 - 10.5.5 Repair: Class 3 leak does not have a required repair schedule providing surveillance continues to classify the leak as Class 3.

11.0 Multiple Public Leak Calls

11.1 When multiple leak calls (3 or more) are received from the public, Gas Supervisor will determine the actions needed to expedite repair and ensure that planned repairs are communicated to:

- 11.1.1 Customer,
- 11.1.2 Adjacent property owners, or
- 11.1.3 Individuals who reported the leak.

11.2 Gas Compliance will run a monthly Outage Analysis System (OAS) report of Multiple Public Leak Calls by address and distribute to the Gas Supervisor to help identify where 3 or more leak calls have been reported within the year.

12.0 Recheck of Repaired Leak

12.1 Below Grade

12.1.1 At the time of leak repair, gas field personnel shall probe soil around excavation (in direction of gas facility) and obtain CGI readings to determine if there is additional leakage potential.

12.1.2 Following the repair, a recheck shall be performed by qualified personnel using CGI to verify leak was successfully repaired.

12.1.3 Where residual gas is detected in the soil,

1. The presence of residual gas shall be documented on the ClickMobile Leak Repair Form.
2. If residual gas readings are detected within 5 feet from the foundation wall:
 - Daily readings shall be performed until there is a 0% LEL gas reading.
 - If daily readings show increased levels of gas, a check shall be made for gas migration inside the structure.

12.1.4 Leak recheck must be performed within 30 days following repair. If natural gas readings are detected, the leak recheck should be completed noting the readings and classifying the leak accordingly.

12.2 Above Grade

12.2.1 Following the repair of an aboveground leak, a final check must be made with leak detection fluid or gas detection instrument to verify no further leak.

12.2.2 No recheck is required.

13.0 Leak Response Time

13.1 Delayed Response Time

13.1.1 Illinois Commerce Commission (ICC) has identified an expected response time for a gas leak or odor complaint.

13.1.2 A response time exceeding *60 minutes* from the time of receipt of call for an indoor or outdoor leak is considered delayed and requires explanation.

13.2 Monitoring, Investigating, and Reporting

13.2.1 Gas Compliance will monitor response times, through OAS system, to ensure compliance with regulatory requirements.

13.2.2 Gas Supervisor will be requested to investigate a delayed response time.

13.2.3 Gas Supervisor will provide Gas Compliance an explanation for delay.

13.2.4 The Dispatch Supervisor will be notified when dispatch time exceeds 15 minutes, contributing to a delayed response time, and asked to investigate.

13.2.5 Dispatch Supervisor will provide Gas Compliance an explanation for delay in assigning investigation order.

13.2.6 Gas Compliance will compile explanations in a monthly report (titled, "Delayed Gas Leak Response Times") for internal use.

14.0 Records (49 CFR §192.603, §192.605, §192.709)

14.1 The edges of the leak should be established and documented in ClickMobile, by probing bar holes in the ground and verifying a clear indication in at least four directions (e.g., N, S, E, & W) in order to determine the limits of the leak.

14.2 Leak investigation, repair, monitor, and recheck information shall be recorded in Click-Mobile.

14.3 The record detail and associated sketches shall be recorded in ClickMobile and retained in Maximo.

14.4 Record Retention:

14.4.1 Leak classification and surveillance records shall be maintained for 6 years.

14.4.2 Leak repair information shall be maintained for life of the facility.

14.4.3 Gas Compliance will maintain the monthly explanation reports titled "Delayed Gas Leak Response Times" (retaining only as long as warranted).

End of Instructions.

Operator Qualification (OQ) Required?

YES

0301: Manually Opening and Closing Valves

1201: Temporary Isolation of Service Lines and Service Discontinuance

1211: Odorization -- Periodic Sampling

1231: Inside Gas Leak Investigation

1241: Outside Gas Leak Investigation

1261: Walking Gas Leakage Survey

1291: Locate Underground Pipelines

Appendices

[Appendix A - Conversion Chart - Natural Gas Readings](#)

[Appendix B - Leak Process Flow Charts](#)

Attachments

NONE.

Compliance Requirements

49 CFR §192.603 Operations: General Provisions

49 CFR §192.605 Operations: Procedural manual or operations, maintenance, emergencies

49 CFR §192.613 Continuing surveillance.

UNCONTROLLED IF PRINTED

- 49 CFR §192.706 Transmission lines: Leakage surveys.
- 49 CFR §192.709 Transmission lines: Record keeping.
- 49 CFR §192.723 Distribution systems: Leakage surveys.

Reference Documents

- [QQAL 1 Operator Qualification: Requirements](#)
- [QQAL 2.01 Operator Qualification: Covered Task List](#)
- [LEAK 2.1 Leak Management: Indoor Investigations](#)
- [LEAK 2.2 Leak Management: Outdoor Investigations](#)
- [LEAK 2.3 Leak Management: Leak Investigation Form](#)
- [LEAK 2.4 Leak Management: Leak Surveys](#)
- [LEAK 2.5 Leak Management: Leak Survey Equipment](#)
- [LEAK 2.6 Leak Management: Walking Leak Surveys](#)
- [LEAK 2.7 Leak Management: Mobile Leak Surveys](#)
- [LEAK 2.9 Leak Management: Survey Maps and Records](#)
- [LEAK 3 Leak Management: Forms and Reference Materials](#)
- [REPR - Repairs](#)

Document Rescission

LEAK 1 Leak Management: Requirements, October 1, 2021.

Revision Notes

Location of Changes	Summary of Changes
Subsection 5.9 – Leak Detection and Classification	New subsection: Leaks identified on AIC facilities during routine work activities shall follow the same classification procedures outlined in this procedure.
Appendix B – Flow Chart	Updated the Leak Process Flow Chart for Below Grade leaks – Under Pavement Extending to Foundation Wall

Appendix A - Conversion Chart - Natural Gas Readings

% LEL	% Gas	Parts Per Million (PPM)
.02	.001	10
0.2	.01	100
2.0	.10	1,000
10	.50	5,000
80	4	40,000
100	5	50,000

UNCONTROLLED IF PRINTED

	100	1,000,000
--	-----	-----------

Appendix B - Leak Process Flow Charts

ABOVE GRADE LEAK

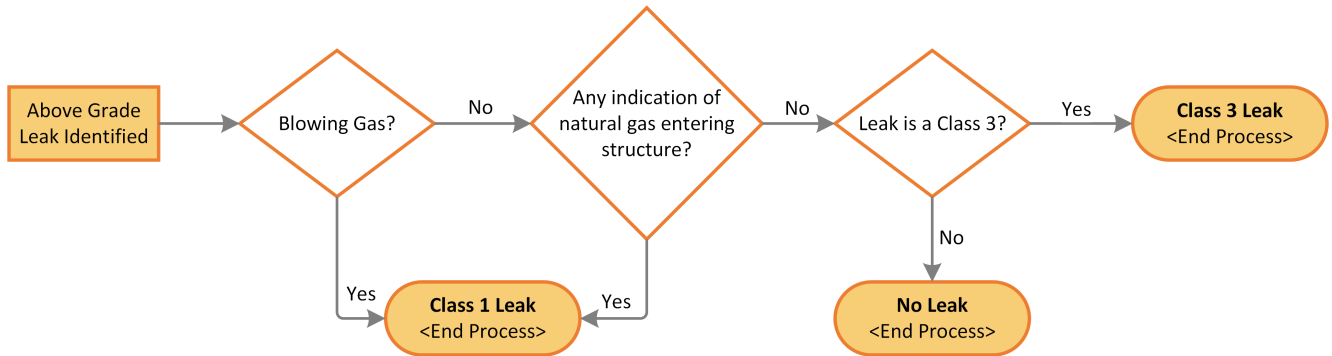

BELOW GRADE LEAK

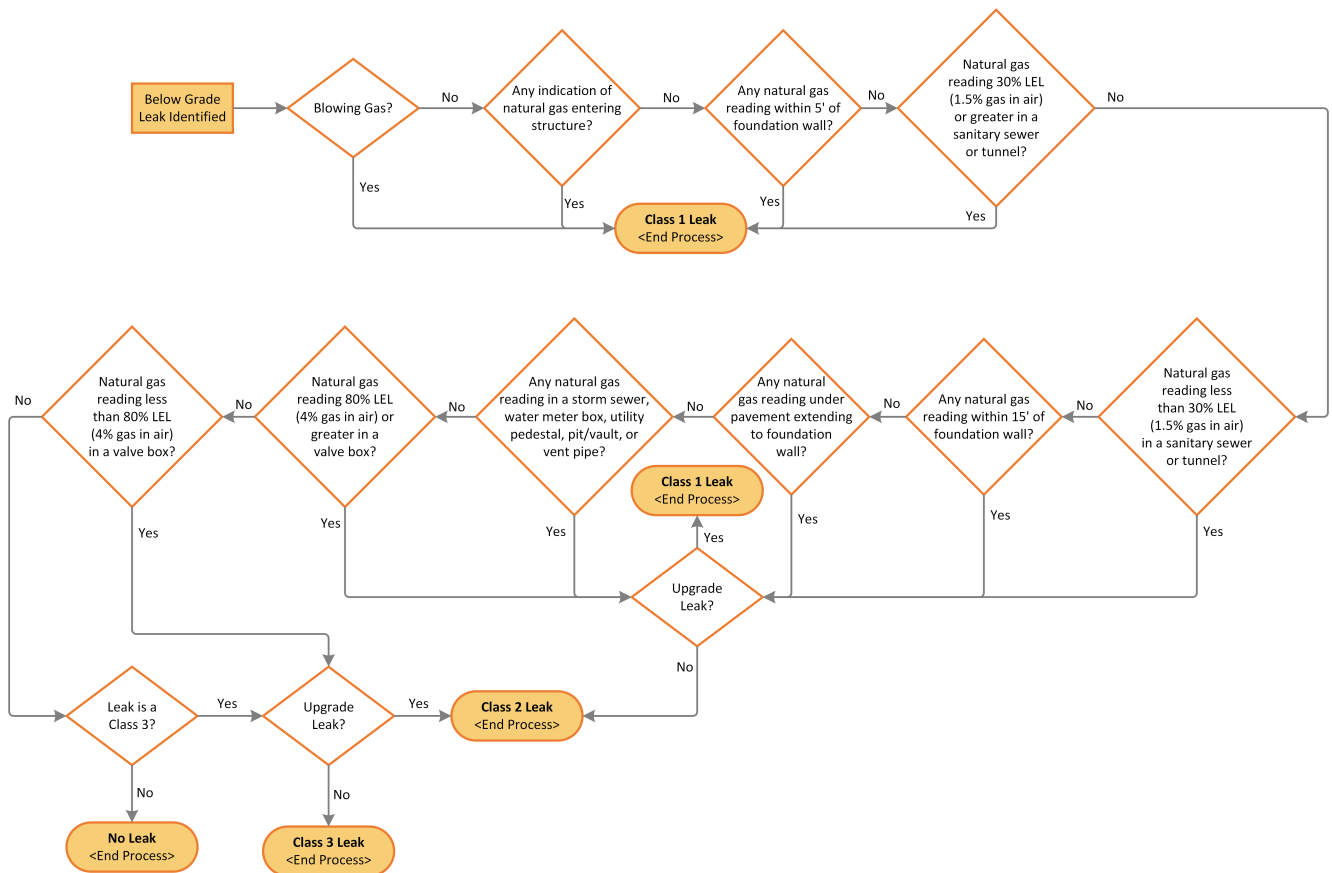

LEAK MANAGEMENT

October 1, 2022

LEAK 2.1 Indoor Investigations

1.0 Purpose

This document describes procedures for Ameren Illinois (AIC) to responsibly address investigation of all indoor reported leaks, doing such in a manner to ensure public and employee safety. Further, this covers proper documentation of the response and investigation.

2.0 Scope

This document addresses the following:

[3.0 Target Audience](#)[4.0 General](#)[5.0 Upon Arrival](#)[6.0 Approaching Structure](#)[7.0 Customer Home](#)[8.0 Customer Not Home or Structure Inaccessible](#)[9.0 Leak on Customer Facility](#)[10.0 Records](#)

Appendices:

[Appendix A - Sample Views of OAS 62, 63, 65, 6F, and 6H](#)**3.0 Target Audience**

- Gas Field Personnel.
- Gas Supervisors.
- Gas Tech Services Personnel.
- Gas Tech Services Supervisors.

4.0 General

- 4.1 AIC shall respond to all leak or odor complaints in a priority manner.
- 4.2 These procedures are organized to address common considerations for investigating indoor complaints.
- 4.3 Where hazardous conditions of 10% LEL (0.5% Gas-In-Air) or greater are found, the Emergency Plan may need to be implemented.

Unless otherwise specified, gas detection is using a Combustible Gas Indicator (CGI) with bar holes or other approved gas detection instrument.

5.0 Upon Arrival

- 5.1 Minimum equipment is CGI, with % LEL and % GAS capability, checked for daily operation. For calibration, see [LEAK 2.5, Section 6.0](#), Combustible Gas Indicator (CGI).

UNCONTROLLED IF PRINTED

FI is not to be used for inside leak investigation.

5.2 Purge and zero the detection instrument in a gas-free environment. Ensure the instrument is on % LEL scale.

5.3 Confirm location of reported complaint. Verify meter number if applicable.

6.0 Approaching Structure

6.1 Observe for indications of gas leakage:

6.1.1 Listen for sound of escaping gas and smell of natural gas odor.

6.1.2 Check the area for dead or dying grass, shrubs, or trees.

6.1.3 Look for signs of recent construction activity that could have damaged gas facilities.

6.2 Before touching gas meter, check the riser, meter set, and customer piping with a volt stick. If voltage stick alarms, refer to [METR 2.2, Section 7.2](#), AC Voltage on Meter Set.



Image of Volt Stick

6.3 Observe test hand on gas meter for rapid movement. If open fuel line is suspected, shut off meter valve.

6.4 Before entering, ensure that all personnel electronic devices, such as cell phones, are powered off and all intrinsically safe equipment, such as CGI and flashlight, are powered on.

The flashlight on the volt stick is not intrinsically safe and should be left off while inside.

6.5 Knock on door -- **Do Not ring the doorbell.**

7.0 Customer Home

7.1 Upon entering the structure:

7.1.1 Sample atmosphere at entrance to determine if immediate hazard exists, holding the intake as high as possible, with CGI set on the LEL scale.

7.1.2. Ask customer where they smell gas odor.

7.1.3 Advise customer not to operate any switches or use any electronic devices, such as cell phone, while the investigations is being conducted.

7.1.4 Continue to monitor the atmosphere while moving to the area where the odor is suspected.

- 7.1.5 Sample atmosphere in areas where customer believes they detected odor.
- 7.2 Monitor the CGI readings for immediate hazardous concentration.
 - 7.2.1 Indoor concentration of gas-in-air at entrance or ambient atmosphere throughout the structure of 10% LEL (0.5% Gas-In-Air) or greater is an immediate hazard and the structure should be evacuated, and [EMER 2.4.1](#) implemented.
 - 7.2.2 If carbon monoxide is detected at a reading of 100 PPM or greater, it is considered hazardous. Gas field personnel should evacuate the structure and not enter until ventilated.
 - 7.2.3 Gas field personnel should:
 - 1. Shut off the gas meter or, if available, customer valve downstream of meter.
 - 2. Call 9-1-1; the fire department may assist with the evacuation and ventilation.
 - 7.2.4 Issue a Warning Tag and advise customer to contact a qualified plumbing or heating professional to have the system checked.
- 7.3 Investigate for the source of leak using CGI, gas detection instrument (except not FI for inside, per **Note** above [under 5.1](#)), and/or leak detection fluid. Check the following:
 - 7.3.1 Structure openings - Inspect the following for migration of gas from an outside source:
 - 1. Gas service entrance.
 - 2. Beam pocket along walls.
 - 3. Water service and utility entrances.
 - 4. Floor drain, sewer entry, and sump pumps.
 - 5. Basement floor along walls and cracks in foundation.
 - 6. Any other points of entry into the structure
 - 7.3.2 Appliances
 - 1. Inspect for leakage.
 - 2. Ensure standing pilots are lit.
 - 3. Check appliances and connectors.
 - 4. If appliance is moved during investigation, recheck connections after appliance is moved back in-place.
 - 7.3.3 Exposed piping - Inspect piping connections and inside meter sets.
- 7.4 If gas is detected migrating into the structure from outside, perform an outdoor leak investigation. See [LEAK 2.2](#).
- 7.5 A shut-in test may not be necessary on all leak investigations. However, when there is inaccessible piping and/or appliances that cannot be readily checked with leak detection instrument or leak detection fluid, a minimum 5-minute shut in test should be performed. See [TURN 2.1](#).
- 7.6 Once the inside leak investigation is complete, check all above grade piping and meter set for leakage to ensure there is no leakage on AIC's above grade facilities.

8.0 Customer Not Home or Structure Inaccessible

- 8.1 Before touching the gas meter, check the riser, meter set, and customer piping with volt stick. If voltage stick alarms, refer to [METR 2.2, Section 7.2](#), AC Voltage on Meter Set.
- 8.2 Investigate the outside perimeter, using CGI, to include checking around:
 - 8.2.1 Windows,
 - 8.2.2 Doors,
 - 8.2.3 Crawl space vents, and
 - 8.2.4 Other openings.
- 8.3 Conduct a perimeter check around foundation and gutter downspout outlets, if tiled away from the foundation. Use a CGI with bar holes, Fi unit or gas detection instrument with ppm sensor capable of detecting 50 ppm.
- 8.4 Check along the gas service line.
- 8.5 If no gas is detected:
 - 8.5.1 Shut-off and "Red Pin" the outside meter valve.
 - 8.5.2 Leave door hanger advising customer their gas service has been disconnected due to a possible gas leak.
 - 8.5.3. Complete Outage Analysis System (OAS) 6H screen, "Red Pin", so Call Taker will see "Hazard Condition" on the account when customer calls. See [Appendix A](#) for sample OAS 6H.

"Red Pin" is a term used when meter valve is locked in closed position due to hazard condition on the customer's facilities. A barrel lock is used to lock the meter, and, in several locations, those barrel locks are painted red.

- 8.6 If gas is detected inside the structure, take the following actions:
 - 8.6.1 Shut-off gas at meter valve and Red Pin or disconnect the service line.
 - 8.6.2 Contact AIC Dispatcher and/or Gas Supervisor - request additional assistance and request they contact proper authorities, such as Fire Department, Police Department, electric and other affected utilities, for possible disconnect.
 - 8.6.3. Check adjacent structures, using CGI.
 - 8.6.4 Check available underground openings (such as sewers and valve boxes) and areas of recent excavation.
 - 8.6.5 Attempt to vent manholes, valve boxes, etc. if any gas is detected.
- 8.7 If forcible entry is required to perform an inside leak investigation, contact the Gas Supervisor. See [EMER 2.4.11](#), Emergency Plan: Gas Field Personnel Loss and Restoration of Service.
- 8.8 Leave door hanger advising customer their gas service has been disconnected due to possible gas leak.

9.0 Leak on Customer Facility

- 9.1 Indoor gas leak on customer facility:

- 9.1.1 Make simple repairs where possible.
- 9.1.2 If simple repair cannot be made, notify customer of gas leak and advise customer that they should have a qualified professional make the repair.
 - 1. Isolate gas leak upstream of leak by shutting off:
 - 1 a. Appliance control valve, or
 - 1 b. Customer owned valve, or
 - 1 c. Locking the meter valve closed.
 - 2. Complete the OAS 6H screen and issue Warning Tag. See [Appendix A](#) and [TURN 2.7](#).
- 9.2 If gas leak is not immediate hazard (i.e., soap-bubble test holds), an exception may be made with Gas Supervisor approval due to:
 - 9.2.1 Cold weather conditions, or
 - 9.2.2 Commercial/industrial process.
- 9.3 Notify customer of the gas leak and advise that they are responsible for repair with following options:
 - 9.3.1 Immediately call a qualified plumbing or heating professional to do repair and AIC will turn leak and Warning Tag over to them upon arrival. Where a commercial/industrial process is involved that has their own in-house maintenance personnel, AIC will turn the leak over to them if maintenance personnel are immediately on-site. Document that leak is turned over to a qualified person on OAS 63 screen (see [Appendix A](#) for sample), or
 - 9.3.2 Isolate the appliance or piping, complete the OAS 6H screen, and issue a Warning Tag. See [TURN 2.7](#).

10.0 Records

- 10.1 If a leak is discovered on AIC facilities, leak investigation shall be initiated within Click-Mobile.
- 10.2 If a previous leak still exists at the address/location, a leak surveillance shall be performed and documented within ClickMobile.
- 10.3 Complete Leak Investigation Form (see [LEAK 2.3](#)), or
- 10.4 If using electronic device, complete appropriate entries on OAS screens 62, 63, 6F, and 6H. See [Appendix A](#) for sample images of OAS screens.

End of Instructions.

Operator Qualification (OQ) Required?

YES

- 0301: Manually Opening and Closing Valves
- 1201: Temporary Isolation of Service Lines and Service Discontinuance
- 1211: Odorization -- Periodic Sampling
- 1231: Inside Gas Leak Investigation
- 1241: Outside Gas Leak Investigation

UNCONTROLLED IF PRINTED

Appendices

[Appendix A - Sample Views of OAS 62, 63, 65, 6F, and 6H](#)

Attachments

NONE.

Compliance Requirements

49 CFR §192.613 Continuing surveillance.

49 CFR §192.709 Transmission lines: Record keeping.

Reference Documents

[OQAL 1 Operator Qualification: Requirements](#)

[OQAL 2.1 Operator Qualification: Covered Task List](#)

[OQAL 4 Operator Qualification: Forms and Reference Materials](#)

[EMER 2.4.1 Emergency Plan: Gas Field Personnel Dispatched to Indoor Odor or Leak](#)

[EMER 2.4.11 Emergency Plan: Gas Field Personnel Loss and Restoration of Service](#)

[LEAK 1 Leak Management: Requirements](#)

[LEAK 2.2 Leak Management: Outdoor Investigations](#)

[LEAK 2.3 Leak Management: Leak Investigation Form](#)

[LEAK 2.4 Leak Management: Leak Surveys](#)

[LEAK 2.5 Leak Management: Leak Survey Equipment](#)

[LEAK 2.9 Leak Management: Survey Maps and Records](#)

[LEAK 3 Leak Management: Forms and Reference Materials](#)

[TURN 2.7 Turn-On Turn-Off: Warning Tag](#)

Document Rescission

LEAK 2.01 Leak Management -- Indoor Leak Investigation, May 15, 2022

Location of Changes	Summary of Changes
Subsection 5.3 – Upon Arrival	Added – Verify meter number if applicable
Subsection 7.5 – Customer Home	Grammatical – "is" replaced "are"

Appendix A - Screen Views of OAS 62, 63, 6F, and 6H

A-1 :OAS 62 Screen

```

DSPLY 62 KEY
*** POAA5062 *** 29-62 TROUBLE ORDER DETAIL/COMPLETION *** 21299 07:34 50
ORDER NO PL TP RECV DEVICE P SVC LT/PAD MNT ADDRESS
212890040 01 GR 0223 X 38051234790 2 DYB 633 DEVONSHIRE DR
FDR: J99121 629 DEVONSHIRE DR
SUB: MRNL PSEUDONODE: MAP: BELLEVILLE IL
ERT: 000000 0000 HR: 0.0 ENT: N RMARKS: Y REL ORDR: CLM NO:
---DISP--- --ARRIVE-- ---CMPL--- ORIGINAL SVC: DYB TRBL CDS: EM GL
ASGN TIME DATE TIME DATE TIME DATE CREW LEADER SZ GRID 26- U-47 TYP OH
TV6J 0226 101621 0243 101621 0348 101621 MALLORY, JAM 1 KVA 0 SIZE 0050
AFFTD 1 CALLS 1
ALERT 0 CBACK ST
WC: CS: IN >DES: N RELIGHT: RL COLL AMT: $0.00 KWH: DISCONNECT:
AC COMPONENT DMG COMPL REQD TAG # ROOT ENGR CS -----LOCATION/DETAILS-----
CPIP LK RP OK
CUST: RUBY L GASTON BY: RUBY L GASTON PH: 618 977 1109
DISP: C152060 RMK: SMELLING GAS ODOR INSIDE IN THE KITCHEN ABOVE THE FURNACE, F
RESTORE 0348 101621 RECV 0223 101621 PRNTD 0000 000000 SEE REMARKS ON 63 OA61
MTR 25875428 E RDG CODE 56000 LOC 8B
STAT CL MTR 47C55743 G RDG CODE 01209 LOC AB METER FIELD ACTION
PF1=HELP PF2=TOP PF3=MAIN MENU PF5=STICKY PF7/8=UP/DOWN PF12=JUMP
TT 0 1,8 A
    
```

A-2: OAS 63 Screen

```

DSPLY 63 KEY Page 01
*** POAA5063 **** COMPLETION DETAIL OVERFLOW **** 21299 07:36 **** 50
Order No PL TP ST Recv Device P Svc LT/PadMnt Address
212890040 01 GR CL 0223 X 38051234790 2 DYB 633 DEVONSHIRE DR
Fdr: J99121 629 DEVONSHIRE DR BELLEVILLE IL
Remarks... Time Date
SMELLING GAS ODOR INSIDE IN THE KITCHEN ABOVE THE FURNACE, F 0223 101621
URNACE WAS SERVICED TODAY AND CO DETECTOR BEEPING 0223 101621
ORDER STATUS SET TO OP BY E44040 ON ORDER 212890040 0223 101621
UPON ARRIVAL MET WITH CUSTOMER. CUSTOMER STATED SHE THOUGHT 0336 101621
SHE SMELLED SOMETHING BUT WAS UNSURE AND CALLED IN BECAUSE 0336 101621
THE CO DETECTOR WAS BEEPING. CUSTOMER ADVISED HER FURN WAS 0336 101621
NOT ON AS SHE WAS TRYING TO SAVE MONEY AND IT WAS NOT COLD 0336 101621
ENOUGH. I CONDUCTED AN INSIDE AND OUTSIDE LEAK 0338 101621
INVESTIGATION. NO GAS READING UPON ENTRY. ALL GAS PIPING WAS 0338 101621
EXPOSED IN THE BASEMENT. A SMALL LEAK WAS FOUND ON THE 0338 101621
SEDIMENT TRAP FOR THE WHTR. NO OTHER LEAKAGE WAS FOUND ON 0339 101621
ANY FITTINGS. I WAS ABLE TO TURN GAS OFF AT THE WEDGE SEAL, 0340 101621
PF1=Help PF2=Top PF3=Main Menu PF7/8=Fwd/Back PF10=Toggle
OA425 MORE INFORMATION AVAILABLE - PF8 TO SCROLL FORWARD...
TT 0 1,8 A
    
```

A-3: OAS 65 Screen

```

DSPLY 65      KEY _____ ACTIVE
*** POAAS065 ***** 29-65 TROUBLE CALL DETAIL ***** 21299 07:39 ** 50
ACCT NO: 7516754097      LIGHT PREM NO:      DEVICE: J99121 38051234790 2
NAME...: RUBY L GASTON      PNODE: 71
SERV...: 633 DEVONSHIRE DR      SERV DATE: 05/19/99
DISCONNECT:
CITY/ST: BELLEVILLE IL      ZIP: 62226      SVC: DYB      ALERT TYPE:
ADMS ORDER:      * * * * *      CSS FLD ORDR #

TROUBLE CODES: EM GL      LIGHT NUM..:
REPORTED BY...: RUBY L GASTON      COLLECT AMT: $0.00
REMARKS.....: SMELLING GAS ODOR INSIDE IN THE KITCHEN ABOVE THE FURNACE, F
URNACE WAS SERVICED TODAY AND CO DETECTOR BEEPING

PHONE: 618 977 1109 EXT:      UPDATE CSS? N OK TO CALLBACK: Y BEFORE:
METER NO CODE LOC | LEAK IND: ODOR Y HEAR Y SEE      APPOINT:
4TC55743 01209 AB | LEAK LOC: INSIDE Y NEAR KITCHEN      | CALL RECV: 10/16/21
25875428 56000 8B |      OUTSIDE NEAR      |      TIME: 02:23:00
| ODOR:      ACCESSIBLE(Y/N)? Y | RECV BY: C154110
| CO: FEEL ILL ALARM QUESTION | CALL 0001 OF 0001
ORDER NO: 212890040 TYPE: GR ST: CL PRILV: 01 RECV DATE/TIME: 10/16/21 0223
PF1=HELP PF2=TOP PF3=MAIN MENU PF5=STICKY PF8=SCROLL FORWARD PF12=JUMP

TTI          *          0 1,8 A
    
```

A-4: OAS 6F Screen

```

DSPLY 6F      KEY _____ ACTIVE
*** POAAS06F ***      GAS LEAK INVESTIGATION DETAIL      *** 21299 07:38 ** 50
ORDER NO ACCOUNT NO PL TP RECV ADDRESS: 633 DEVONSHIRE DR
212890040 7516754097 01 GR 0223      BELLEVILLE IL
*** INDOOR INVESTIGATION ***      *** OUTDOOR INVESTIGATION ***
CGI/FI SERIAL # : 4243346483      C=TEST COMPLETE NA=NOT APPLICABLE
1.INITIAL CGI READING (LEL) : 000 % 1.CHECK OUTSIDE AREA : C
2.APPLIANCES: INSPCT LEAKAGE : C 2.GAS SAMPLING-ALONG MAIN : C
PILOTS LIT : C CONNECTORS : C AT THE SERVICE TEE : C
3.CHECK EXPOSED PIPING : C ALONG SERVICE LINE : C
4.GAS SERVICE ENTRANCE : C AT THE METER SET : C
BOX SILL : C FOUNDATN CRACKS : C ALONG BUILDING FOUNDATION : C
WATER N UTILITY ENTRANCE : C CUST YARD LINES AND FUEL LINES : C
DRAIN, SEWER, SUMP PUMPS : C ADJACENT BUILDING FOUNDATIONS : C
BASEMENT FLOOR ALONG WALLS : C ADJACENT METER SETS : C
5.TURN OFF APPLIANCE VALVES : C ADJACENT SERVICE LINES : C
LOW FLOW TEST : C SOAP TEST : C SEWERS : C
CONDUCT 5 MIN SHUT-IN TEST : NA VAULTS AND UNDERGROUND CONDUIT : NA
6.ODORANT READILY DETECTED(Y/N/NA): Y 3.ODORANT READILY DETECTED(Y/N/NA): Y

LEAK FOUND ON AMEREN FACILITIES (Y/N): N
ALL GAS LEAK INVESTIGATION INFO COMPLETE: Y
GAS SUPERVISOR APPROVAL ID: E29991
PF1=HELP PF3=MAIN MENU
OAS371 ORDER IS CLOSED. CAN NOT CHANGE ORDER.

TTI          *          0 1,8 A
    
```

A-5: OAS 6H Screen

The 6H display allows for entry, verification and removal of gas hazard information for a premise. When hazard is added to a premise, a special notation is added to CSS. When a hazard is removed from the premise, the special notation is removed from CSS.

```

DSPLY PH KEY
*** POAA506H ***** 29-6H GAS HAZARDOUS CONDITIONS ***** 21344 13:48 ** 50
ACCT NO: 7516754097 PREMISE: 754128553
NAME...: RUBY L GASTON
SERV...: 633 DEVONSHIRE DR

CITY/ST: BELLEVILLE IL ZIP: 62226 SVC: DYB
*****
AC STA DT HAZARDOUS CONDITION DESCRIPTION ST OAS ORD # EMP #
- - - - -
- - - - -
- - - - -
- - - - -
- - - - -
- - - - -
- - - - -
- - - - -
- - - - -
- - - - -
- - - - -
- - - - -

OAS ORDER: 212890040 ALL HAZARD INFO COMPLETE? Y/N _
PF1=HELP PF2=TOP PF3=MAIN MENU PF5=STICKY PF7/8=UP/DOWN
OA286 ORDER IS CANCELLED, CLOSED, EXPORTED, OR RESTORED

```

TI = 0 1.8 A

UNCONTROLLED IF PRINTED

LEAK MANAGEMENT

April 1, 2023

LEAK 2.2 Outdoor Investigations

1.0 Purpose

This document describes procedures for Ameren Illinois (AIC) to responsibly address investigation of all outdoor reported leaks, doing such in a manner to ensure public and employee safety. Further, this covers proper documentation of the response and investigation.

2.0 Scope

This document addresses the following:

[3.0 Target Audience](#)[4.0 General](#)[5.0 Upon Arrival](#)[6.0 Below-Grade Gas Facilities](#)[7.0 Above-Grade Gas Facilities](#)[8.0 Classifying Outdoor Leaks](#)[9.0 Hazardous Conditions](#)[10.0 Leaks on Customer-Owned Facilities](#)[11.0 Records](#)**3.0 Target Audience**

- Gas Field Personnel.
- Gas Supervisors.
- Gas Tech Services Personnel.
- Gas Tech Services Supervisors.

4.0 General

- 4.1 AIC shall respond to all leak or odor complaints in a priority manner.
- 4.2 This procedure is organized to address common considerations for outdoor investigations followed by specifics for outdoor complaints.
- 4.3 Where hazardous conditions of 30% LEL (1.5% Gas-In-Air) or greater are found, the Emergency Plan may need to be implemented.

Unless otherwise specified, gas detection is using a Combustible Gas Indicator (CGI) with bar holes, Flame Ionization Detector (FI), or other approved gas detection instrument.

5.0 Upon Arrival

- 5.1 Minimum equipment for investigation is:
 - 5.1.1 CGI, or
 - 5.1.2 FI Device, or

UNCONTROLLED IF PRINTED

- 5.1.3 Other gas detection instrument capable of detecting gas concentration of 50 ppm gas in air.
- 5.1.4 Bar Hole Probe or drive rod.

Instruments shall be calibrated and checked for daily operation in accordance with manufacturers' instructions.

- 5.2 Purge and zero instrument in a gas-free environment. Where applicable, ensure instrument is on % LEL scale. See [LEAK 2.5](#).
- 5.3 Confirm location of reported complaint. Verify meter number if applicable.
- 5.4 Attempt to contact customer who made report of odor for all available information.
- 5.5 Based on information received from customer or caller, assess area for immediate hazards and migration. Take necessary action to protect life and property.
- 5.6 Thoroughly inspect area for any of the following items, using sense of sight, smell, and hearing:
 - 5.6.1 Outdoor odors.
 - 5.6.2 Dead or dying vegetation.
 - 5.6.3 Unusual changes to the soil.
 - 5.6.4 Dry blowing dirt.
 - 5.6.5 Bubbling water.
 - 5.6.6 Sounds of escaping gas.
 - 5.6.7 Unusual swarm of insects.
 - 5.6.8 Recent construction activities.
 - 5.6.9 Extensive corrosion or physical damage of facilities.

6.0 Below-Grade Gas Facilities

- 6.1 Gas detection instrument or FI unit can be used to check for migration near a foundation and for initial identification of general location of possible leak. If ground is frozen, bar holes may be required. Investigation should include the following locations:
 - 6.1.1 Along the main.
 - 6.1.2 At service tee.
 - 6.1.3 Along service line.
 - 6.1.4 At meter set.
 - 6.1.5 Along building foundation.
 - 6.1.6 Along customer yard lines and fuel lines.
 - 6.1.7 Along foundations of adjacent buildings.
 - 6.1.8 Adjacent meter sets.
 - 6.1.9 Adjacent service lines.
 - 6.1.10 Along sewer lines.

UNCONTROLLED IF PRINTED

6.1.11 Around vaults and underground conduits.

6.2 If gas leak is detected, sampling of subsurface environment is required.

6.2.1 Sampling of subsurface environment must be done at sufficient intervals and locations to ensure safety of persons and property in surrounding area. It is critically important to confirm that gas has not migrated to a structure.

If gas is detected at the foundation of a structure, the structure shall be immediately checked for possible presence of gas.

6.2.2 Sampling requires checking bar holes with CGI having a bar hole probe.

6.2.3 If necessary, locate gas lines in vicinity of leak investigation.

6.2.4 Give specific attention to gas lines located in areas of recent construction activity or crossing buried foreign facilities.

6.2.5 Bar holes should be approximate equal depth.

6.2.6 Start bar hole spacing at 6 to 10 feet apart until the approximate limit of gas migration is defined. Then, reduce spacing to about 2 feet until highest concentration of gas is found. To pinpoint leak, reduce interval to approximately 1 foot.

6.3 Once leak location is determined, additional samples should be taken to determine perimeter of leak migration.

6.3.1 Adjust bar/test hole spacing to identify extent of migration in a minimum of 4 directions.

6.3.2 Record bar hole locations and % gas readings as used to determine leak classification on the leak sketch within ClickMobile. Use comments section to provide added particulars that support sketch.

6.4 If you suspect migration to a structure, obtain additional samples inside. For possible hazardous condition, see [Section 9.0](#).

6.5 Ground/surface conditions that do not allow for accurate pinpointing of gas leak may require:

6.5.1 Drilling of purge hole.

6.5.2 Utilizing air mover to ventilate purge holes, thus, to void holes of natural gas. See [PURG 3](#) for Vapor Extraction Unit (VEU) manufacturer's instructions.

6.5.3 Allowing sufficient time for gas vapors to build-up.

6.5.4 Checking gas concentration in purge holes with CGI to determine which have higher concentration.

6.6 If gas concentration is detected in a sewer line, the following steps should be taken:

6.6.1 Consider possible migration into premises. Check along sewer laterals, including available outside sewer clean-outs. If necessary, attempt access to customer premise to verify whether or not gas has migrated into premise.

6.6.2 Until an ethane identifier has been used to verify source as either foreign gas or natural gas, investigation shall assume source to be natural gas.

- 6.6.3 If reading is 30% LEL or greater, *initiate Emergency Plan* as described in [EMER 2.4.4](#), Emergency Plan: Gas Field Personnel Dispatched to Gas in a Sewer Hazardous Condition.
- 6.6.4 If reading less than 30% LEL, expand investigation by checking nearest sewer manhole and/or points of entry:
 - 1. Request additional assistance if needed.
 - 2. Consider contacting municipal sewer department for sewer layout and access location.
- 6.6.5 If there is a detectable reading greater than 2% LEL in manhole and/or point of entry, classify the leak appropriately.

7.0 Above-Grade Gas Facilities

- 7.1 All above-grade facilities should be checked for leaks, such as:
 - 7.1.1 Before touching gas meter, check the riser, meter set, and customer piping with volt stick. If voltage is present, contact Gas Supervisor to initiate investigation for source prior to any work. See [METR 2.2, Section 7.2](#), AC Voltage on Meter Set.
 - 7.1.2 Regulator station.
 - 7.1.3 Above-grade valve station.
 - 7.1.4 Odorizer.
 - 7.1.5 Any other above-grade AIC facilities.
 - 7.1.6 Customer owned natural gas facilities such as; standby generators, pool heaters, barbecue, etc.

8.0 Classifying Outdoor Leaks

- 8.1 Can only be classified once extent of leak is known.
- 8.2 All below-grade leaks are to be classified in accordance with [LEAK 1, Section 5.0](#), Leak Detection and Classification.

9.0 Hazardous Conditions

- 9.1 First priority is to determine whether there is a hazardous condition. The following would be considered hazardous and may require implementation of [EMER 2.4.2](#), Emergency Plan: Gas Field Personnel Dispatched to Outdoor Odor or Leak.
 - 9.1.1 A reading in air at 30% LEL (1.5% gas-in-air) or greater in:
 - 1. Open environment where gas could enter a structure or ignition source located in close proximity.
 - 2. A sanitary sewer.
 - 9.1.2 Blowing gas.
 - 9.1.3 Suspected damaged gas facility.
 - 9.1.4 Gas along a foundation or gas migrating into a structure.

A pad constructed with concrete or other structural material used to support such things as: sign, stand-by generator, antenna, tower, grain bin, or any structure not meant for a person to enter

UNCONTROLLED IF PRINTED

should not be considered a foundation when classifying a gas leak.

Exception: Pad located adjacent to foundation of a structure where a person can enter, and underground sampling cannot be performed between pad and foundation to verify gas is not migrating under or into the structure.

9.1.5 Gas along a foundation where there is no access to the structure.

9.1.6 Any leak, which in the judgement of qualified personnel at scene, is regarded as potentially hazardous.

9.2 Gas field personnel shall remain at site of hazardous leak until leak is repaired.

9.3 If necessary, request additional resources to establish and maintain a safety zone to prevent unauthorized personnel from entering until repairs are made or the situation made safe.

9.4 If there is indication of gas migrating into a structure where gas field personnel cannot gain access, see [LEAK 2.1, Section 8.0](#), Customer Not Home or Structure Inaccessible.

10.0 Leaks on Customer-Owned Facilities

10.1 If a gas leak is discovered on a customer-owned, buried fuel line or an aboveground, outdoor fuel line that is a potential hazard:

10.1.1 Make simple repairs where possible.

10.1.2 If simple repairs cannot be made, notify customer of gas leak and advise customer that they should have a qualified professional make the repair (see [10.2 below](#)).

1. If leak is on customer fuel line that extends into the structure:

I. Shutting off customer owned valve, or

II. Isolate the gas leak at meter valve and "Red Pin" the meter valve closed.

"Red Pin" is a term used when meter valve is locked in closed position due to hazard condition on the customer's facilities. A barrel lock is used to lock the meter and, in several locations, those barrel locks are painted red.

1 b. Complete the OAS 6H screen and issue a Warning Tag, See [TURN 2.7](#).

2. If leak is on customer fuel line or facility that is separate from structure:

2 a. Isolate gas leak at one of the following:

- Customer valve.
- Meter valve.

2 b. If isolated at the meter valve, lock/"Red Pin" the meter valve closed.

- 2 c. Complete the OAS 6H screen and issue Warning Tag, See [TURN 2.7](#).
3. If gas leak is not immediate hazard, an exception may be made with Gas Supervisor approval due to:
 - 3 a Cold weather conditions, or
 - 3 b. Commercial/industrial process.

10.2 Notify customer of the gas leak and advise that they are responsible for repair with following options:

10.2.1 Immediately call a qualified plumbing or heating professional to do repair and AIC will turn leak and Warning Tag over to them upon arrival. Where a commercial / industrial process is involved that has their own in-house maintenance personnel, AIC will turn the leak over to them if maintenance personnel are immediately on-site. Document turning over the leak to a qualified person on OAS 63 screen (see LEAK 2 for image), or

10.2.2 Isolate customer piping, complete the OAS 6H screen (see [LEAK 2.1](#) for image), and issue a Warning Tag. See [TURN 2.7](#).

11.0 Records

- 11.1 If a leak is discovered on AIC facilities, leak investigation shall be initiated within Click-Mobile.
- 11.2 If a previous leak still exists at the address / location, a leak surveillance shall be performed and documented within ClickMobile.
- 11.3 Complete Leak Investigation Form (see [LEAK 2.3](#)) for all leaks on AIC facilities, or
- 11.4 If using MDT, make appropriate entries on OAS Screens 62, 63, 65, 6F, and 6H. See [LEAK 2.1 Appendix A](#) for sample OAS Screens.

End of Instructions.

Operator Qualification (OQ) Required?

YES

0301: Manually Opening and Closing Valves

1201: Temporary Isolation of Service Lines and Service Discontinuance

1211: Odorization -- Periodic Sampling

1231: Inside Gas Leak Investigation

1241: Outside Gas Leak Investigation

Appendices

NONE.

Attachments

NONE.

Compliance Requirements

49 CFR §192.613 Continuing surveillance.

49 CFR §192.709 Transmission lines: Record keeping.

UNCONTROLLED IF PRINTED

Reference Documents

[QQAL 1 Operator Qualification: Requirements](#)

[QQAL 2.1 Operator Qualification: Covered Task List](#)

[QQAL 4 Operator Qualification: Forms and Reference Materials](#)

[EMER 2.4.2 Emergency Plan: Gas Field Personnel - Dispatched to Outdoor Odor or Leak](#)

[EMER 2.4.4 Emergency Plan: Gas Field Personnel - Dispatched to Gas in a Sewer - Hazardous Condition](#)

[LEAK 1 Leak Management: Requirements](#)

[LEAK 2.1 Leak Management: Indoor Investigations](#)

[LEAK 2.3 Leak Management: Leak Investigation Form](#)

[LEAK 2.4 Leak Management: Leak Surveys](#)

[LEAK 2.5 Leak Management: Leak Survey Equipment](#)

[LEAK 2.9 Leak Management: Survey Maps and Records](#)

[LEAK 3 Leak Management: Forms and Reference Materials](#)

[METR 2.2 Metering: Meter Inspection and Testing - Field](#)

[TURN 2.7 Turn-On Turn-Off: Warning Tag](#)

Document Rescission

LEAK 2.2 Leak Management -- Outdoor Leak Investigation, October 1, 2022

Revision Notes

Location of Changes	Summary of Changes
Paragraph 6.5.2	Added Reference Link – See PURG 3 for Vapor Extraction Unit (VEU) manufacturer's instructions.

LEAK MANAGEMENT

October 1, 2022

LEAK 2.3 Leak Investigation Form

1.0 Purpose

This describes the documentation for Ameren Illinois (AIC) addressing the response and investigation of all odor complaints and leaks in accordance with applicable federal / state requirements. It is typically documented in the OAS system or on the ClickMobile Leak Investigation Form or paper Gas Leak Investigation Form.

2.0 Scope

This document addresses the following:

[3.0 Target Audience](#)[4.0 General Information \(Top Block of Form\)](#)[5.0 Indoor Leak Investigation Record](#)[6.0 Outdoor Leak Investigation Record](#)[7.0 Back-Page Information](#)[8.0 Records Retention](#)[9.0 Gas Leak Investigation Form](#)

Appendices:

[Appendix A - Gas Leak Investigation Form](#)[Appendix B: ClickMobile Leak Investigation Form](#)**3.0 Target Audience**

- Gas Field Personnel.
- Gas Tech Services Personnel.
- Gas Supervisors.
- Gas Tech Services Supervisors.

4.0 General Information (Top Block of Form)**4.1 Gas Leak Investigation Form: Form A-2551, Stock Code 37-21-992**

For field personnel without access to electronic device, this general information on leak call is recorded on the top portion of form (see [Appendix A](#)). Guidance for entering items is as follows:

- 4.1.1 OAS No. - Obtain from Dispatcher.
- 4.1.2 Date - Record actual date of leak complaint.
- 4.1.3 Call Receive Time - Obtain from Dispatcher.
- 4.1.4 Dispatch Time - Reference assignment by Dispatcher.
- 4.1.5 Arrive Time - Enter arrival time at reported leak location.
- 4.1.6 Complete Time - Enter time of completing investigation.
- 4.1.7 Reason for Call - Obtain from Dispatcher.

UNCONTROLLED IF PRINTED

- 4.1.8 Customer Name - Obtain from Dispatcher.
- 4.1.9 Customer Address - Obtain from Dispatcher.
- 4.1.10 Meter Number - Obtain from Dispatcher and confirm at premise.
- 4.1.11 Account Number - Obtain customer number from Dispatcher.

4.2 Electronic Device User: OAS 62 and 06F Screen

For field personnel who utilize electronic device, the "Top Block General Information" on the 62 and 06F screens (see [LEAK 2.1, Appendix A](#) for images) is automatically populated from AIC Customer Service System (CSS), with exception of the following:

- 4.2.1 Dispatch Time - Dispatcher enters when qualified person accepts order.
- 4.2.2 Arrival Time - Enter arrival time at reported leak location.
- 4.2.3 Complete Time - Enter time of completing investigation.

5.0 Indoor Leak Investigation Record

If any of the following tasks are not applicable, place "N/A" on appropriate line of Gas Leak Investigation Form (see [Appendix A](#)) or type "N/A" on the OAS 06F screen. Indicate completed tasks by entering (√) on appropriate Form line or "C" on OAS 06F screen.

5.1 Initial CGI Reading at Entrance of Building

- 5.1.1 Upon entering building, take initial CGI reading just inside entrance.
- 5.1.2 Record initial reading from LEL scale.

5.2 Check All Appliances

- 5.2.1 Ensure pilots are lit.
- 5.2.2 Check for leakage, including all connectors.
- 5.2.3 If a leak is found, record findings:
 - 1. On back of form under "Leaks Found and Action Taken," or
 - 2. On OAS 63 screen

5.3 Check Exposed Piping

- 5.3.1 Check all exposed piping connections with soap solution or electronic gas detection instrument.
- 5.3.2 If a leak is found, record findings:
 - 1. On back of form under "Leaks Found and Action Taken," or
 - 2. On OAS 63 screen.

5.4 Check Building Openings - Using an CGI and/or electronic gas detection instrument

- 5.4.1 Check for gas concentration at gas service entrance.
- 5.4.2 Check box sill along foundation wall.

UNCONTROLLED IF PRINTED

- 5.4.3 Check water service and other utility entrances.
- 5.4.4 Check floor drain and sewer entry or sump pump.
- 5.4.5 Check basement floor along walls and any cracks in foundation.
- 5.4.6 If a leak is found, record findings:
 - 1. On back of form under "Leaks Found and Action Taken," or
 - 2. On OAS 63 screen.

5.5 Check Meter Set - Indoor or outside

- 5.5.1 Turn off all appliance valves.
- 5.5.2 Conduct low flow meter test to ensure low flow rate registers. See [TURN 2.1](#).
- 5.5.3 Conduct 5-minute shut-in test.
- 5.5.4 Soap all pipe connections on meter set.
- 5.5.5 If a leak is found, record findings:
 - 1. On back of form under "Leaks Found and Action Taken," or
 - 2. On OAS 63 screen.

5.6 Odorant Readily Detected

- 5.6.1 Conduct sniff test at convenient location to determine if odorant is readily detected. Mark N/A if unable to perform a sniff test.
- 5.6.2 Record "Y" (Yes) or "N" (No) after completing task.
- 5.6.3 If "N" is recorded:
 - 1. Report situation to Gas Supervisor immediately.
 - 2. Record findings on back of form under "Leaks Found and Action Taken," or
 - 3. Enter on OAS 63 screen.

6.0 Outdoor Leak Investigation Record

If any of the following tasks are not applicable, place "N/A" on appropriate line of Gas Leak Investigation Form (see [Appendix A](#)) or type "N/A" on the OAS 06F screen. Indicate completed tasks by entering (√) on appropriate Form line or "C" on OAS 06F screen.

6.1 Check Outside Area

- 6.1.1 Check area for natural gas or like odors.
- 6.1.2 Leaks above ground facilities.
- 6.1.3 Dead or dying vegetation.
- 6.1.4 Unusual soil changes.
- 6.1.5 Dry blowing dirt.

UNCONTROLLED IF PRINTED

6.1.6 Bubbling water.

6.1.7 Unusual swarm of insects.

6.1.8 Extensive corrosion, or damage to facilities.

6.1.9 Recent construction or excavation activity, fence installation, settling or subsidence.

6.1.10 If indication of gas is detected from any of above observations:

1. Soap the above ground facilities.
2. Sample subsurface environment with CGI to verify presence of gas.

6.1.11 If a leak is found, record findings:

1. On back of form under "Leaks Found and Action Taken," or
2. On OAS 63 screen.
3. If leak is on AIC facility, document leak and surveillance information in Click-Mobile.

6.2 Perform Sampling (with approved leak detection instrument)

6.2.1 Perform gas sampling.

1. Along the main.
2. At service tee.
3. Along service line.
4. At meter set.
5. Along building foundation.
6. Along customer yard lines and fuel lines.
7. Along foundations of adjacent buildings.
8. Adjacent meter sets.
9. Adjacent service lines.
10. Along sewer lines.
11. Around vaults and underground conduits.

6.2.2 If a leak is detected:

1. Quantify the concentrations using CGI and bar holes.
2. Record findings on back of form under "Leaks Found and Action Taken," or
3. Enter findings on OAS 63 screen.
4. If leak is on AIC facility, document leak and surveillance information in Click-Mobile.

6.3 Bar Test Meter Riser

6.3.1 Bar test riser using probe rod and CGI, or

6.3.2 Leak survey service with FI or gas detection instrument.

6.3.3 If a leak is found, record findings:

UNCONTROLLED IF PRINTED

1. On back of form under "Leaks Found and Action Taken," or
2. On OAS 63 screen.
3. If leak is on AIC facility, document leak and surveillance information in Click-Mobile.

6.4 Odorant Readily Detected - At a convenient location

- 6.4.1 Conduct sniff test to determine if odorant is readily detected.
- 6.4.2 Record "Y" for Yes or "N" for No after completing task.
- 6.4.3 If "N" is recorded:
 1. Report situation to Gas Supervisor immediately.
 2. Record findings on back of form under "Leaks Found and Action Taken," or
 3. On OAS 63 screen.

7.0 Back-Page Information

7.1 Leaks Found and Action Taken

- 7.1.1 Detail the leak(s) that was discovered.
- 7.1.2 Describe action taken.
- 7.1.3 When using OAS, record leaks found and actions taken on OAS 63 screen.

7.2 Carbon Monoxide (CO) Found and Action Taken

- 7.2.1 Detail the readings, symptoms, or signs that indicated the presence of CO.
- 7.2.2 Describe action taken.
- 7.2.3 When using OAS, record carbon monoxide found and action taken on OAS 63 screen.

7.3 Follow-up Action

- 7.3.1 List any needed actions to complete the investigation, repairs, or restoration.
- 7.3.2 When using OAS, record follow-up actions on OAS 63 screen and immediately report to Gas Supervisor.
- 7.3.3 When using OAS, show follow-up action that requires gas construction crew:
 1. AP the OAS order that automatically creates DOJM Work Request.
 2. Notify Gas Supervisor.
 3. Leak repair order will be available for completion by crew in ClickMobile.

7.4 Investigation Completed By:

- 7.4.1 Gas field personnel completing investigation shall sign form.
- 7.4.2 When using OAS, gas field personnel completing investigation to be identified on OAS 62 screen.

7.5 CGI/FI Serial Number

- 7.5.1 Record serial number of CGI/gas detection instrument/FI unit used during investigation.
- 7.5.2 When using OAS, document information on OAS 06F screen.

UNCONTROLLED IF PRINTED

7.6 Approval

7.6.1 Gas Supervisor shall review/approve (sign and date) investigation.

7.6.2 When using OAS, Gas Supervisor approves by entering initials on OAS 63 screen and AIC employee number on OAS 06F screen.

8.0 Records Retention

8.1 Records pertaining to leak investigations, classification, and surveillance shall be maintained for 6 years. That includes:

8.1.1 Gas Leak Investigation Form.

8.1.2 OAS documentation.

8.1.3 ClickMobile/Maximo leak investigation/surveillance work orders.

9.0 Gas Leak Investigation Form

9.1 See [Appendix A](#).

End of Instructions.

Operator Qualification (OQ) Required?

YES

1211: Odorization - Periodic Sampling

1231: Inside Gas Leak Investigation

1241: Outside Gas Leak Investigation

1261: Walking Gas Leakage Survey

1271: Mobile Gas Leakage Survey - Flame Ionization

1281: Mobile Gas Leakage Survey - Optical Methane

Appendices

[Appendix A - Gas Leak Investigation Form](#)

[Appendix B: ClickMobile Leak Investigation Form](#)

Attachments

NONE.

Compliance Requirements

49 CFR §192.613 Continuing surveillance.

49 CFR §192.706 Transmission lines: Leakage surveys.

49 CFR §192.723 Distribution systems: Leakage surveys.

Reference Documents

[OQAL 1 Operator Qualification: Requirements](#)

[OQAL 2.01 Operator Qualification: Covered Task List](#)

[LEAK 1 Leak Management: Requirements](#)

UNCONTROLLED IF PRINTED

[LEAK 2.1 Leak Management: Indoor Investigations](#)

[LEAK 2.2 Leak Management: Outside Investigations](#)

[LEAK 2.8 Leak Management: Survey Maps and Records](#)

[TURN 2.1 Turn-On Turn-Off: Residential/Small Commercial Customer](#)

Document Rescission

LEAK 2.3 Leak Management – Leak Investigation Form, October 1, 2021

Revision Notes

Location of Changes	Summary of Changes
1.0 Purpose	Added; ClickMobile Leak Investigation Form
2.0 Scope – Appendices	Added: Appendix B: ClickMobile Leak Investigation Form
Appendix B:	ClickMobile Leak Investigation Form

Appendix A: Gas Leak Investigation Form

[\(View/download PDF version.\)](#)



GAS LEAK INVESTIGATION FORM

OAS No. _____ Date: _____ Call Receive Time: _____ Arrive Time: _____
 GCS No. _____ Dispatch Time: _____ Complete Time: _____
 Reason For Call: _____

Customer Name: _____
Customer Address: _____
Meter No. _____ **Account No.** _____

Indoor Investigation

An indoor leak investigation shall be performed using the LEL scale of a CGI. Once it is determined that there is not an immediate hazard, electronic leak detection instruments can be used to pinpoint a leak.

If the initial CGI reading at the entrance to the building or throughout the building is equal to or greater than 10% LEL, there is an immediate hazard. The building should be evacuated and the Emergency Plan implemented.

If Building is not Accessible:

- Shut off and lock the meter valve _____
- Report no access to the Dispatcher or Gas Supervisor _____

(Items 2-6: Check (√) when completed or write N/A if not applicable to the investigation)

1. **Initial CGI Reading at Entrance of Building**
 - Record initial reading from LEL scale _____ %
2. **Check All Appliances (√)**
 - Inspect for leakage _____
 - Make sure pilots are lit _____
 - Appliance connectors _____
3. **Check Exposed Piping (√)**
 - Piping connections with soap or leak detection instrument _____
4. **Check Building Openings (√)**
(Use leak detection instruments or CGI)
 - Gas service entrance _____
 - Box sill along foundation wall _____
 - Water service and utility entrance _____
 - Floor drain, sewer entry, sump pumps _____
 - Basement floor along walls _____
 - Cracks in foundation _____
5. **Check Meter Set (√)**
 - Turn off all appliance valves _____
 - Conduct low flow meter test _____
 - Soap test all meter connections _____
 - Conduct a five minute, shut-in test _____
6. **Odorant Readily Detected**
 - Record Yes (Y) or No (N) _____

Outdoor Investigation

An outdoor leak investigation shall be performed using a CGI or FI unit. If an initial CGI reading in a sanitary sewer is greater than 30% LEL (1.5% Gas-In-Air) or a reading in the air of 30% LEL (1.5% Gas-In-Air) or greater, there is an immediate hazard and the Emergency Plan should be implemented. If gas is discovered along a foundation, an indoor leak investigation shall be performed to determine if gas is migrating into the building.

*All leaks on Company facilities must be classified according to the **Leak Classification and Surveillance** section of the O&M Plan. If a leak is discovered underground on Company facilities, a GCS Leak Case Field Report shall be completed and recorded in the system. If a leak is discovered above ground on Company facilities and **not** immediately repaired, a GCS Leak Case Field Report shall be completed and recorded in the system. Any above ground leaks on Company facilities that are immediately repaired are only required to be documented on the Gas Leak Investigation Form.*

(Items 1-3: Check (√) when complete or write N/A if not applicable to the investigation)

1. **Check Outside Area (√)**
 - Natural gas or like odors; Leaks on above ground facilities; Dead or dying vegetation; Unusual soil changes; Dry blowing dirt; Bubbling water; Unusual swarm of insects; Extensive corrosion of facilities; Damage to facilities _____
2. **Perform Subsurface Sampling (√)**
 - Along the main _____
 - At the service tee _____
 - Along the service line _____
 - At the meter set _____
 - Along the building foundation _____
 - Customer yard lines and fuel lines _____
 - Adjacent building foundations _____
 - Adjacent meter sets _____
 - Adjacent service lines _____
 - Sewers _____
 - Vaults and underground conduits _____
3. **Odorant Readily Detected**
 - Record Yes (Y) or No (N) _____

Carbon Monoxide Found and Action Taken:

Follow-up Action:

Investigation Completed By: _____ CGI/FI Serial Number: _____

Approved By: _____ Date: _____

This completed form shall be kept on file for six (6) years.

Appendix B: ClickMobile Leak Investigation Form

Leak Investigation ClickMobile Form – Effective October 2020

Leak Location:

Blowing Gas?

Any indication of natural gas entering structure?

Any natural gas reading within 5' of foundation wall?

Natural gas reading 30% LEL (1.5% gas in air) or greater in a sanitary sewer or tunnel?

Natural gas reading less than 30% LEL (1.5% gas in air) in a sanitary sewer or tunnel?

Any natural gas reading within 15' of foundation wall?

Any natural gas reading under pavement extending to foundation wall?

Any natural gas reading in a storm sewer, water meter box, utility pedestal, pit/vault or vent pipe?

Natural gas reading 80% LEL (4% gas in air) or greater in a valve box?

Natural gas reading of less than 80% LEL (4% gas in air) in a valve box?

Leak is Class 3?

Upgrade leak due to frozen ground, concrete or asphalted Surface, heavily traveled area, public building, or condition which may affect the migration of gas?

LEAK MANAGEMENT

October 1, 2022

LEAK 2.4 Leak Surveys

1.0 Purpose

This describes procedure to be used by Ameren Illinois (AIC) gas field personnel and contracted companies to obtain consistent and quality leak surveys on all AIC facilities. It details the equipment, techniques, documentation requirements, weather considerations, and added survey checks for conducting leak surveys on transmission lines, mains, service lines, meter sets, and in business districts. All gas facilities are classified as either "Transmission" or "Distribution" and shall be leak surveyed using the type of surveys addressed.

2.0 Scope

This document addresses the following:

[3.0 Target Audience](#)[4.0 Transmission Lines](#)[5.0 High-Pressure Distribution Mains and Services](#)[6.0 Business Districts](#)[7.0 Yardlines](#)[8.0 Inside Meter Set](#)[9.0 Uprotected Steel Lines](#)[10.0 Common Survey Actions and Considerations](#)[11.0 Inaccessible Gas Facilities](#)

3.0 Target Audience

- Gas Field Personnel.
- Gas Supervisors.
- Leak Surveyor
- Gas Tech Services Personnel.
- Gas Tech Services Supervisors.

4.0 Transmission Lines (49 CFR §192.706)

4.1 Definition of *Transmission Line*:

- 4.1.1 Transports gas from gathering lines or storage facility to a gas distribution center, storage facility, or large volume customer that is not downstream from a gas distribution center.
- 4.1.2 Gas pipeline operating at or above 20% SMYS.
- 4.1.3 Transports gas within a storage field.
- 4.1.4 Other pipelines as may be designated as transmission by AIC-Pipeline Integrity Group.

4.2 Frequency of leak surveys is based on Class Location; applies to both odorized and non-odorized lines.

- 4.2.1 Class 1 and 2 -- survey *once each calendar year* (not to exceed 15 months).

UNCONTROLLED IF PRINTED

4.2.2 Class 3 -- survey *2 times each calendar year* (not to exceed 7-1/2 months).

4.2.3 Class 4 -- survey *4 times each calendar year* (not to exceed 4-1/2 months).

1. AIC-Pipeline Integrity Group determines / designates Class locations.
2. AIC does not have facilities in Class 4 locations.

4.3 Farm taps and service lines extending off transmission lines *are not classified Transmission* but should be leak surveyed once annually along with associated transmission pipeline surveys.

4.4 See [Section 10.0](#) for Common Survey Actions and Considerations.

5.0 High-Pressure Distribution Mains and Services (49 CFR §192.723)

5.1 Definition of *Distribution Line*:

5.1.1 Pipeline other than gathering or transmission line.

5.1.2 Gas pipeline/main that operates at less than 20% SMYS.

High-pressure distribution main and services, MAOP greater than 60 psig but less than 20% SMYS, are covered under Distribution Leak Surveys.

5.2 Frequency and extent of leak surveys are:

5.2.1 Steel lines are categorized as being under cathodic protection or no protection.

1. Survey cathodically protected steel mains and services *once every 4 calendar years* (not to exceed 51 months).

Atmospheric corrosion monitoring survey, as required under §192.481 and [CORR 1 Paragraph 15.3.2](#), is included in the distribution mains and services leak surveys.

2. Survey unprotected steel mains and services *once every 3 calendar years* (not to exceed 39 months).

5.2.2 Survey plastic mains and services *once every 4 calendar years* (not to exceed 51 months).

5.3 See [Section 10.0](#) for Common Survey Actions and Considerations.

6.0 Business Districts (49 CFR §192.723)

6.1 Definition of *Business District*:

6.1.1 Represents the primary business area in a community.

- 6.1.2 Area where majority of buildings on either side of street are utilized for commercial, industrial, financial, religious, educational, health, or recreational purposes.
- 6.1.3 Area where gas mains and services are under continuous pavement extending either from the road centerline to building walls or from main to building wall.

These areas have potential for any leaking gas to migrate under pavement to the building wall - creating a hazardous condition.

6.2 Other areas for consideration by the Gas Supervisor:

6.2.1 Examples:

- 1. Schools.
- 2. Churches.
- 3. Areas of commercial development, such as strip malls and shopping centers.
- 4. Nursing homes and healthcare facilities.
- 5. Civic Centers or community buildings.

6.2.2 These areas should be included in a Business District Survey if there is continuous pavement over AIC gas facilities from main to the building wall.

6.2.3 Region Engineering and gas supervision should review Business District areas *periodically, not to exceed 5 years* (commenced in 2015).

6.3 Frequency of leak surveys: *once each calendar year* (not to exceed 15 months).

6.4 Meter and related piping:

6.4.1 Inside meters are to be included in survey.

FI unit is not to be used for surveying inside meter sets.

6.4.2. Inside meter surveys shall include a leak survey of outside service line and inside gas facilities.

6.4.3 A visual inspection should be performed of meter set and piping condition (to the building wall).

6.4.4 Gas detection equipment and/or leak detection fluid shall be used to check meter set and primary fuel line piping from building wall to gas meter for leakage.

6.5 Inside service regulators shall have their regulator vent and relief vent piped and terminated outdoors. The relief vent shall terminate such that gas can escape freely to the atmosphere and away from ignition sources or openings into the structure.

6.6 See [Section 10.0](#) for common survey actions and considerations.

7.0 Yardlines

7.1 Definition of *Yardline* and related leak survey:

- 7.1.1 A yardline is a residential customer's underground primary fuel line where the gas meter is more than 3 feet from the outside wall of the residential structure being served.
- 7.1.2 If multiple structures are served from 1 gas meter, structure means the first building nearest to service line connection.
- 7.1.3 If gas meter is more than 3 feet from mobile home or trailer, customer's buried fuel line is from meter outlet to trailer skirting (or perimeter of trailer if no skirting).
- 7.1.4 Yardline leak survey begins at outlet of meter and ends at outside wall of structure being served.
- 7.2 Gas Supervisor will maintain lists of all residential yardlines in Maximo.
- 7.3 Should the customer's yardline location be unknown, the FI survey must be performed along entire side of premise/trailer where the yardline is likely located.
- 7.4 AIC is responsible for primary yardline. Secondary lines, such as gas line to gas grill, gas yard lights, or additional structures, are customer's responsibility.
- 7.5 Conduct yardline surveys *once every 3 calendar years* (not to exceed 39 months).
- 7.6 Leaks found on yardlines must be made safe.
 - 7.6.1 A contract surveyor will call the AIC emergency phone number (1.800.755.5000) to report leak. AIC gas field personnel will contact the Gas Supervisor or AIC designee.
 - 7.6.2 An OAS EMGL will be created, and a qualified gas field person dispatched to respond to the leak.
 - 7.6.3 Leak surveyor will remain at site until first responder arrives.
- 7.7 Repair of gas leak found on yardline:
 - 7.7.1 Consider replacing existing yardline/service line and/or relocate gas meter to within 3 feet of structure, thereby eliminating yardline.
 - 7.7.2 If service line is not replaced and/or relocated, follow the same procedures as stipulated in [LEAK 2.2, Section 10](#), Leaks on Customer-Owned Facilities.
- 7.8 If unqualified piping is found on a yardline, meter valve shall be closed and locked. A Hazardous Warning Tag shall be issued to the customer indicating that an immediate hazard exists and notified that:
 - 7.8.1 They are responsible for making repairs.
 - 7.8.2 Service will not be restored until unqualified pipe is replaced with qualified piping for natural gas service.
 - 7.8.3 Consideration should be given to replacing existing service line and/or relocating gas meter to within 3 feet of the structure, thereby eliminating yardline.

Unqualified pipe is pipe that is not approved or classified for underground natural gas use, i.e. PVC water/sewer pipe, rubber hoses.

8.0 Inside Meter Sets

8.1 Definition of *Inside meter sets*:

8.1.1 Those meters located outside of Business Districts that are installed inside buildings, structures, or dwellings.

8.2 Effort should be made to schedule moving these meters outside.

8.3 Inside meter surveys are either maintained and surveyed under a separate Leak Survey ID or included in leak surveys for respective Distribution and High-Pressure Distribution Mains and Services.

8.4 Inside meter surveys shall include a leak survey of outside service line and inside gas facilities.

FI unit is not to be used for surveying inside meter sets.

8.5 In addition to performing leak survey on inside meters, a visual inspection should be performed of meter set and piping condition (to the building wall).

8.6 Frequency of inside meter leak surveys is:

8.6.1 Survey cathodically protected steel systems or plastic piping *once every 4 calendar years* (not to exceed 51 months).

8.6.2 Survey unprotected steel systems *once every 3 calendar years* (not to exceed 39 months).

9.0 Unprotected Steel Lines

9.1 Perform survey in same manner as Distribution Mains and Services Survey in [Section 5.0](#) with exception of frequency.

9.2 Frequency of surveying unprotected steel pipelines and services is once every 3 calendar years (not to exceed 39 months).

10.0 Common Survey Actions and Considerations (where applicable)

10.1 Include leak survey of service line to outlet of gas meter.

10.2 If gas meter has underground fuel line more than 3 feet from the residential structure, record the location for Gas Supervisor to check appropriate yardline survey listing.

10.2.1 If needed, Gas Supervisor will add the location to appropriate yardline survey.

10.3 Gas detection equipment and/or leak detection fluid shall be used to check meter set from building wall to meter.

10.4 Meter, regulator, and piping must be inspected for evidence of tampering, vandalism, or damage.

10.5 Meter set and piping should also be inspected for:

10.5.1 Possibility of AC voltage by checking with "volt stick" prior to physically touching meter set. See [METR 2.2 Section 7.0](#) Meter Header Inspection

10.5.2 Undue piping strain.

10.5.3 Atmospheric corrosion.

- 10.5.4 Foreign grounding from telephone or cable TV.
- 10.5.5 Relief valve vented to the outside atmosphere away from openings into structure and where vented gas will not accumulate.
- 10.5.6 Bug screen present in vents for relief valve, farm tap regulator, and service regulator.
- 10.5.7 Corroded bolts on banded regulators (Rockwell 8012, Lancaster Model 61, Universal Model 61). See [METR 2.2, Appendix B](#) for pictures.
- 10.5.8 Check for substandard regulators and regulators containing mercury. Notify Gas Supervisor if any are encountered. See [METR 2.2, Appendix B](#) for pictures.
 - 1. Substandard Regulators: Fisher 733-C2, Fisher 738.
 - 2. Mercury Regulators: Fisher 102-4, Reynolds Model 20.
- 10.5.9 Any regulator or relief valve found inside a building or garage that is not vented to outside shall be reported to Gas Supervisor for follow-up investigation and action.
- 10.6 If any above deficiencies are noted, repair immediately or report within ClickMobile for follow-up action.

11.0 Inaccessible Gas Facilities

- 11.1 During any leak survey, there may be facilities identified as inaccessible:
 - 11.1.1 Because of restricted access due to locked fence.
 - 11.1.2 Hazards due to aggressive dogs.
 - 11.1.3 Where customer has not been responsive to multiple contacts by AIC to survey the facilities.
- 11.2 These inaccessible facilities must be surveyed, isolated, or physically disconnected from gas supply by the required survey compliance date.

End of Instructions.

Operator Qualification (OQ) Required?

YES

- 0301: Manually Opening and Closing Valves
- 1201: Temporary Isolation of Service Lines and Service Discontinuance
- 1261: Walking Gas Leakage Survey
- 1271: Mobile Gas Leakage Survey - Flame Ionization
- 1281: Mobile Gas Leakage Survey - Optical Methane

Appendices

NONE.

Attachments

NONE.

Compliance Requirements

UNCONTROLLED IF PRINTED

- 49 CFR §192.706 Transmission lines: Leakage surveys.
- 49 CFR §192.709 Transmission lines: Record keeping.
- 49 CFR §192.723 Distribution systems: Leakage surveys.

Reference Documents

- [QQAL 1 Operator Qualification: Requirements](#)
- [QQAL 2.01 Operator Qualification: Covered Task List](#)
- [LEAK 1 Leak Management: Requirements](#)
- [LEAK 2.2 Leak Management: Outdoor Investigations](#)
- [LEAK 2.3 Leak Management: Leak Investigation Form](#)
- [METR 2.2 Metering: Meter Inspection and Testing - Field](#)

Document Rescission

LEAK 2.4 Leak Management – Leak Surveys, December 15, 2021

Revision Notes

Location of Changes	Summary of Changes
Subsection 6.5 – Inside regulators	Revised to comply with the Code 192.355; Inside service regulators shall have their regulator vent and relief vent piped and terminated outdoors. The relief vent shall terminate such that gas can escape freely to the atmosphere and away from ignition sources or openings into the structure.

LEAK MANAGEMENT

April 1, 2023

LEAK 2.5 Leak Detection Equipment

1.0 Purpose

This document describes equipment / instruments that can be used by Ameren Illinois (AIC) personnel (and contracted companies) in performing **leak investigations and** leak surveys. Gas detection instruments are key requirement for safe and accurate investigation of gas leak calls and for required leak surveys.

2.0 Scope

This document addresses the following:

[3.0 Target Audience](#)**[4.0 General](#)****[5.0 Portable Flame Ionization Instrument](#)****[6.0 Combustible Gas Indicator \(CGI\)](#)****[7.0 Gas Detection Instrument](#)****[8.0 Mobile Flame Ionization Unit \(FI\)](#)****[9.0 Remote Methane Detector \(RMD\)](#)****[10.0 Laser Spectroscopy - Advance Mobile Leak Detection \(AMLD\)](#)****[11.0 Records](#)****3.0 Target Audience**

- Gas Field Personnel.
- Gas Supervisors.
- Leak Surveyor
- Gas Tech Services Personnel.
- Gas Tech Services Supervisors.

4.0 General

- 4.1 All gas detection instruments must be checked and calibrated in accordance with procedures in the instrument operating manual to ensure dependable and accurate operation.
- 4.2 This procedure typically addresses requirement for monthly calibration of gas detection instruments plus daily operational checks.
- 4.3 Manufacturers' manuals for instruments being used at AIC are in **[LEAK 3](#)**.
- 4.4 As new leak equipment is evaluated / approved by Gas Standards group, applicable manuals will be added at appropriate O&M update.

5.0 Portable Flame Ionization Instrument (FI)

- 5.1 Used only for outside leak surveys.
- 5.2 Must take continuous samples capable of detecting 50 ppm gas-in-air concentration.
- 5.3 Samples must be taken at or near ground level when surveying buried facilities.

UNCONTROLLED IF PRINTED

- 5.4 Instrument shall be inspected / calibrated monthly in accordance with the manufacturer's operating manual (see [LEAK 3.](#)) and action recorded in Maximo. See [Section 11.0.](#)
- 5.5 Follow manufacturer's operating instructions on unit being used for start-up procedures, required maintenance (e.g., filter changes), daily operational check, and operating instructions.
- 5.6 A daily operational check should be performed prior to beginning survey in accordance with manufacturer's instructions / recommendations. If unit is used on daily basis for leak survey activity, it should be checked with the 50-ppm test/bump gas at end of day's activity to verify unit's sensor is responsive.
- 5.7 The bottle of hydrogen/nitrogen gas mixture that has sat in storage and not used for a long period (e.g., month or longer) should be rolled prior to filling the FI unit's cylinder, thus, to eliminate any separation that may have occurred. Bottles/cylinders that are being transported in vehicles will not have a mixture separation issue and do not need to be rolled prior to filling the FI unit's cylinder.

6.0 Combustible Gas Indicator (CGI)

- 6.1 Must be capable of detecting and measuring gas concentration in air as %LEL and/or %Methane.
- 6.2 Required for pinpointing and classifying underground leaks.
- 6.3 Requires use of probe rod for subsurface sampling.
- 6.4 Follow manufacturer's instruction manual for calibration procedure, daily operational check, unit inspection and maintenance, and operating instructions. See [LEAK 3.](#)
- 6.5 CGI calibration:
 - 6.5.1 Calibrate monthly and record in Maximo.
 - 6.5.2 Calibration is dependent on sensors installed in unit.
 - 6.5.3 Use a combination of test gas and line (system) gas.
 - 6.5.4 All CGI instruments are equipped with LEL and methane sensors. Calibrate as follows:
 1. Zero the %LEL and %gas sensors.
 2. Connect unit to a calibration test gas of 2.5% methane.
 3. Auto-calibrate or adjust the LEL sensor to read 50% LEL.
 4. Connect unit to test gas or line (system) gas.
 5. The %gas sensor should auto-calibrate or be adjusted to read 100% gas.
 - 6.5.5 Majority of CGIs are equipped with additional sensors that monitor carbon monoxide and oxygen level.
 - 6.5.6 Carbon monoxide test gas is 100 ppm carbon monoxide and normally comes as combination gas with 2-½% methane.
 - 6.5.7 Zero the CO sensor:
 1. Connect instrument to calibration source of 100 ppm CO test gas.
 2. CO sensor should auto-calibrate or be adjusted to read 100 ppm.

6.5.8 A sensor that cannot be accurately auto calibrated or adjusted should be replaced and unit recalibrated.

6.6 CGI operational checks:

6.6.1 *Daily or prior-to-use* following manufacturer's operating procedures for inspection:

1. Visually inspect the instrument for dirty filters, damaged components, or missing parts.
2. Check the sampling system for leaks.
3. Check for low-battery display or indication.
4. Zero the sensors.

6.6.2 *Weekly* verify sensors are functioning by:

1. Exposing instrument to a source of natural gas or bump gas; or
2. Registering a gas concentration during leak investigation.

7.0 Gas Detection Instrument

7.1 Gas detection instrument (GDI) can be used in place of FI unit when equipped with a ppm sensor when equipped with a ppm sensor capable of detecting 50 ppm.

7.2 Instrument can be used for short duration or intermittent leak surveys where use of FI unit is impractical.

7.3 Instrument can be used for leak surveying providing the manufacturer has specifically designed and specified it for such. Operator to then follow the manufacturer's operating instructions.

7.4 An electronic CGI equipped with PPM sensor capable of detecting 50 ppm gas-in-air is considered a GDI.

7.5 Manufacturer's specifications list instruments ppm sensitivity and resolution.

7.6 Samples must be taken at or near ground level when surveying buried facilities.

7.7 In "tick" mode, this instrument can be used for pinpointing an aboveground leak or providing indication that a combustible gas may be present.

7.8 Instrument's CGI sensors, such as LEL, Gas, and CO, shall be inspected and calibrated on a *monthly basis* (see [Section 6.0](#)) and recorded in Maximo (see [Section 11.0](#)).

7.9 A daily operational check with the 50-ppm ($\pm 10\%$) test/bump gas should be performed prior to beginning survey in accordance with manufacturer's instructions / recommendations. See [LEAK 3](#). If used daily for leak survey activity, unit should be checked with the 50-ppm test/bump gas at end of day's activity to verify unit's sensor is responsive.

7.10 Follow the instrument's operating/instruction manual for calibration procedure, daily operational check, instrument inspection and maintenance, and operating instructions.

8.0 Mobile Flame Ionization Unit (FI)

8.1 A standard FI unit is mounted on a motorized vehicle such as truck, car, or ATV. See [Section 5.0](#).

8.2 Sampling system is mounted on the outside and normally on front of vehicle.

8.3 Ensure FI unit is connected to sampling system in accordance with manufacturer's operating instructions.

UNCONTROLLED IF PRINTED

- 8.4 Follow the manufacturer's operating instructions on FI unit for start-up procedures, required maintenance (e.g., filter changes), daily operational check, and operating instructions. See [LEAK 3](#).
- 8.5 If FI unit is being utilized on daily basis for leak survey activity, the unit should be checked at end of day's activity to verify it is still operating properly.

9.0 Remote Methane Detector (RMD)

- 9.1 **RMD instruments** utilizes laser technology, Tunable Diode Laser Absorption Spectroscopy, to detect methane. **RMD instruments read and display in PPM*M (parts per million meter).**
- 9.2 **RMD instruments** can:
- 9.1.1 Detect methane gas up to 100 feet away.
 - 9.1.2 Be used in conjunction with Walking Leak Survey.
 - 9.1.3 Enable leak surveying of facilities that are difficult to access:
 - 1. Exposed facilities crossing creek or deep ravine.
 - 2. Facilities located in difficult terrain.
 - 3. Gas lines suspended under or along bridges.
 - 4. Under heavily traveled roadways.
 - 5. Aboveground facilities that are behind locked fences.
 - 6. Indoor commercial piping.
 - 7. Service lines.
 - 8. Inside meter sets if visible through a window.
 - 9. Can scan the area if exact location cannot be determined.
- 9.3 See manufacturer's operating manual for operating instructions, calibration, daily check, and required maintenance. See [LEAK 3](#).
- 9.4 Instrument must be calibrated in accordance with manufacturer's operating instructions and recorded in Maximo.

10.0 Laser Spectroscopy - Advanced Mobile Leak Detection (AML D)

- 10.1 AMLD uses a laser in a closed optical cavity that consists of two highly reflective mirrors. The laser reflects within the mirrors thousands of times giving an effective path length of several kilometers.
- 10.2 AMLD technology can detect methane at 1 ppb. It can also detect the presence of ethane down to 5 ppb.
- 10.3 The presence of methane could cause a signal (audio and visual), which is transmitted to the display in vehicle. Any other indications of methane that is not alerted to the display will be identified in reporting files.
- 10.4 The cavity of the analyzer is mounted on the inside of the vehicle and relies on a sample of the atmosphere from outside the vehicle.
- 10.5 The sampling system is mounted on the outside of the vehicle, normally on the front bumper.

- 10.6 AMLD units will operate in conjunction with a sonic anemometer mounted on the vehicle.
- 10.7 AMLD is not required to straddle the buried gas facility being surveyed. It can detect potential leaks up to hundreds of feet away.
- 10.8 The AMLD unit is self-calibrating during each start-up sequence.
- 10.9 Follow the manufacturer's operating instructions on AMLD unit for start-up procedures, required maintenance (e.g., filter changes), daily operational check, and operating instructions. See [LEAK 3 - ABB Ability Mobile Gas Leak Detection System \(Mobile-Guard\)](#) for manufacturer's instructions.

11.0 Records (49 CFR §192.709)

- 11.1 Calibration records for CGI and FI units are required *monthly*.
- 11.2 *Maintain calibration records* in Maximo for 6 years.
- 11.3 No record of CGI and FI daily operational checks is required.

End of Instructions.

Operator Qualification (OQ) Required?

YES

- 1231: Inside Gas Leak Investigation
- 1241: Outside Gas Leak Investigation
- 1261: Walking Gas Leakage Survey
- 1271: Mobile Gas Leakage Survey - Flame Ionization
- A004 Advanced Mobile Gas Leakage Survey: Laser Spectroscopy

Appendices

NONE.

Attachments

NONE.

Compliance Requirements

- 49 CFR §192.706 Transmission lines Leakage surveys.
- 49 CFR §192.709 Transmission lines Record keeping.
- 49 CFR §192.723 Distribution systems Leakage surveys.

Reference Documents

- [OQAL 1 Operator Qualification: Requirements](#)
- [OQAL 2.01 Operator Qualification: Covered Task List](#)
- [LEAK 1 Leak Management: Requirements](#)
- [LEAK 2.1 Leak Management: Indoor Investigations](#)
- [LEAK 2.2 Leak Management: Outdoor Investigations](#)

UNCONTROLLED IF PRINTED

[LEAK 2.4 Leak Management: Leak Surveys](#)

[LEAK 2.6 Leak Management: Walking Leak Surveys](#)

[LEAK 2.7 Leak Management: Mobile Leak Surveys](#)

[LEAK 2.8 Leak Management: Advanced Mobile Leak Surveys](#)

[LEAK 3 Leak Management: Forms and Equipment References](#)

Document Rescission

LEAK 2.5 Leak Management – Leak Surveys -- Equipment, October 1, 2022

Revision Notes

Location of Changes	Summary of Changes
Header	Title Change – Leak Detection Equipment
1.0 Purpose	Revised to indicate equipment is used in performing leak investigations and leak surveys. Removed the reference to LEAK 2.4 Leak Surveys.
2.0 Scope	Removed the following sections: Gas-Trac Optical Methane Detector Corrected section name – Laser Spectroscopy – Advance Mobile Leak Detection (AMLD)
Subsection 5.4 – Portable FI	Updated reference link – Section 11.0 Records
Subsection 7.8 - Gas Detection Instrument	Updated reference link – Section 11.0 Records
Former Section 8.0 - Gas-Trac	Removed – Instrument no longer being used.
Section 8.0 – Mobile Flame Ionization Unit	Replaced Gas-Trac section
Section 9.0 – Remote Methane Detector (RMD)	Updated Section name to Remote Methane Detector (RMD)
Subsection 9.1	Revised – RMD instruments utilize laser technology
Subsection 9.2	New – RMD instruments can: 9.2.1 - Detect methane gas up to 100 feet away. 9.2.2 - Be used in conjunction with Walking Leak Survey. 9.2.3 - Enable leak surveying of facilities that are difficult to access.
Section 10.0	Is now Laser Spectroscopy – Advanced Mobile Leak Detection (AMLD)
Subsection 10.9 – AMLD	Update reference link description: ABB- Ability Mobile Gas Leak Detection System (MobileGuard)

UNCONTROLLED IF PRINTED

Section 11.0 = Optical Methane Detector (OMD)	Removed – AIC does not use an OMD.
Section 11.0	Is now Records
Operator Qualifications (OQ) Required	Removed – 1281 – Mobile Gas Leakage Survey – Optical Methane

LEAK MANAGEMENT

October 1, 2020

LEAK 2.6 Walking Leak Surveys

1.0 Purpose

The walking leak survey shall be performed with an industry recognized leak survey instrument that has been approved by the Ameren Illinois (AIC) Gas Standards and Procedures work group and performed in a manner to ensure public and employee safety.

2.0 Scope

This document addresses the following:

[3.0 Target Audience](#)[4.0 General](#)[5.0 Instrument Use](#)[6.0 Survey Routing](#)[7.0 Surveying Service Lines](#)[8.0 Outside Meter Set, Farm Tap, Regulator Station](#)[9.0 Fenced Facilities](#)[10.0 Inaccessible Facilities](#)[11.0 Weather Limitations](#)[12.0 Leak Detection - Using Gas Detection or FI Unit](#)[13.0 Remote Methane Leak Detector \(RMLD\) Survey](#)**3.0 Target Audience**

- Gas Field Personnel.
- Gas Supervisors.
- Gas Tech Services Personnel.
- Gas Tech Services Supervisors.
- Leak Surveyors.

4.0 General

- 4.1 Individuals performing leak survey should familiarize themselves with the gas system to be surveyed. This can be accomplished by reviewing gas system maps with local Gas Supervisor and/or gas field personnel prior to beginning survey.
- 4.2 Surveyors should be observant for gas locate marks, pipeline markers, street patches, gas valve boxes, or other aboveground facilities that indicate presence of buried gas line.
- 4.3 Arrangements should be made between surveyors, Gas Supervisor, and local gas personnel on accessing or obtaining information from service record cards, as-built construction plans, or any other available records.
- 4.4 Operation of gas leak detectors may be based on Flame Ionization, laser diode, infrared, hyperspectral imaging technology, optical methane detection, or catalytic combustion. See [LEAK 3](#) for manufactures' operating instructions.

UNCONTROLLED IF PRINTED

5.0 Instrument Use

- 5.1 Flame Ionization (FI) instrument, laser diode-based gas detection instrument, or Gas Detection Instrument intake should be as close to ground surface as practical.
- 5.2 In dry conditions, the intake cone should be dragged or placed along/or on the ground depending on design of detection unit being used.
- 5.3 Probe stiffener, if equipped, should be fully retracted when dragging intake cone.
- 5.4 Instrument intake probe should be moved slowly from side to side as surveyor walks along general location of gas line.
- 5.5 In areas with decaying vegetation, enough hydrocarbons are present to key the alarm. This can be significantly reduced by lifting instrument intake up 1 to 2 inches.
- 5.6 Instrument intake should not be dragged through wet grass, water, mud, or any other wet condition.
- 5.7 Walk at speeds slow enough to allow adequate sample to be continuously obtained by positioning intake cone over the most logical venting locations.

6.0 Survey Routing

- 6.1 *Areas with vegetative cover:* Leak survey should follow, as close as possible, the route of gas main and/or service. At minimum, the following items should be sampled when readily observed and are within 1 to 2 steps either side of the route:
 - 6.1.1 Manholes.
 - 6.1.2 Catch basins.
 - 6.1.3 Electrical and telephone duct openings.
 - 6.1.4 Water meter boxes.
 - 6.1.5 Regulator pits.
- 6.2 Vegetation survey can be used in conjunction with walking survey by providing an indication of possible gas leak:
 - 6.2.1 Unusual changes to soil.
 - 6.2.2 Dead or dying vegetation, shrubs, or trees.
 - 6.2.3 Dry blowing dirt.
 - 6.2.4 Bubbling water.
 - 6.2.5 Unusual swarm of insects.
- 6.3 *Mains and services:* Piping under concrete or other hard surface will be surveyed by sampling along the route of main and/or service lines at the following:
 - 6.3.1 Along curb lines.
 - 6.3.2 Along cracks or expansion joints in the immediate area.
 - 6.3.3 Manholes.
 - 6.3.4 Catch basins.
 - 6.3.5 Electrical and telephone duct openings.
 - 6.3.6 Water meter boxes.
 - 6.3.7 Along foundation walls.

6.3.8 Any point where gas could vent.

6.4 *Agricultural areas*: Leak survey should be performed when crop height or density will not hinder the surveyor in walking the approximate location of gas line or ability to detect leakage.

7.0 Surveying Service Lines

7.1 Service lines will be surveyed by sampling over most likely route and over areas where vegetation survey indicated possibility of gas leak. The instrument intake probe should be moved slowly from side to side as the surveyor walks along the general gas line location.

7.2 Different paths will be walked going from main to gas meter and back to main to increase probability of surveying over service line.

7.3 When surveyor is unable to determine the location of service line/meter, the surveyor should walk an "H" pattern at the structure.

7.4 Service lines with outside meter sets will be surveyed to outlet of meter.

8.0 Outside Meter Set, Farm Tap, Regulator Station

8.1 Below-grade leak survey should continue up to point where riser breaks through surface.

8.2 Use sweeping motion over aboveground piping and facilities. If instrument is equipped with probe stiffener, the stiffener can be used to extend probe, if necessary, to sweep over aboveground piping.

8.3 Sweeping motion over farm tap and outside meter set is an approximate 2- second sweep with approximate 6-inch separation between intake cone and piping.

8.4 Sweeping motion on meter set begins at riser and ends at outlet of meter.

8.5 Sweeping motion over regulator station, large commercial / industrial meter set, or extensive aboveground piping facility needs intake cone approximately 6 inches above piping and may take longer than 2 seconds.

8.6 All leak indications on exposed piping will be checked and verified with leak detection fluid.

8.7 If leak detection instrument indicates a leak, but no leak is detectable on AIC- owned facilities, surveyor will continue investigation on customer-owned facilities.

8.8 Surveyor shall follow the procedures contained in [LEAK 1, Section 5.0](#), Leak Detection and Classification.

8.9 Surveyor will initiate Leak Investigation Form in ClickMobile.

9.0 Fenced Facilities

9.1 Fenced gas facilities that are inspected annually may include:

9.1.1 Regulator station.

9.1.2 Valve station.

9.1.3 Pipeline delivery point.

9.1.4 Odorizer.

9.2 These leak surveys will be performed by Gas Tech Service personnel and documented on designated form in ClickMobile. Survey will be inside the fenced area.

UNCONTROLLED IF PRINTED

- 9.3 All fenced gas facilities (including below-grade and above-grade piping) to be leak surveyed and documented on Leak Survey task.
 - 9.3.1 Survey can be performed during annual inspection.
 - 9.3.2 If an odorizer is located within same fenced area, odorizer piping to be included in Leak Survey ID and documented on Leak Survey task.
- 9.4 Facilities associated with transmission surveys in Class 3 location to be surveyed *2 times each calendar year* (not to exceed 7-1/2 months).
 - 9.4.1 First survey will be performed during annual inspection and documented on appropriate inspection task.
 - 9.4.2 Second survey will be documented under its own designated Leak Survey task.
- 9.5 Stand-alone odorizers that are fenced will have their own designated Leak Survey task with a designated due and compliance date.
 - 9.5.1 Those odorizers classified as transmission facility will be surveyed *annually*; however,
 - 9.5.2. Those transmission odorizers in a Class 3 location will be surveyed *2 times each year* (not to exceed 7-1/2 months).
- 9.6 Fenced gas facilities that are not inspected annually may include:
 - 9.6.1 Valve stations.
 - 9.6.2 Large meter sets.
 - 9.6.3 If the leak surveyor cannot gain access inside the fenced area, it will be reported as an "Inaccessible Facility" within ClickMobile.

10.0 Inaccessible Facilities

- 10.1 Facilities that cannot be accessed during leak survey shall be reported by surveyor as Inaccessible Facility in ClickMobile.
- 10.2 Gas Supervisor will arrange to have buried and aboveground facilities inside fenced area leak surveyed within compliance date of the associated leak survey.
- 10.3 Associated leak survey cannot be closed until all inaccessible facilities have either been leak surveyed or disconnected from service.

11.0 Weather Limitations

- 11.1 Gas detector design or adverse conditions may limit the use of Walking Leak Survey.
 - 11.1.1 Adverse conditions that should be taken into considerations in determining if weather or conditions are unsuitable for a walking leak survey.
 1. Steady rain.
 2. Standing water.
 3. Heavy frost layer.
 4. Ice covering the ground surface.
 5. High or gusting winds.
- 11.2 If surface areas to be leak surveyed is predominately covered by one or any combination of first four conditions above, a walking survey should not be performed in that

area. Survey can be moved to areas not experiencing these conditions, such as areas where facilities are located under concrete or other solid surfaces.

- 11.3 Steady wind speeds approximating 25 mph or greater will quickly dissipate gas venting from the ground surface, which may result in an inaccurate leak survey. When continuous high wind exists, surveyor should move to areas that are shielded from high steady winds by buildings or geographic features.
- 11.4 If necessary to leak survey when ground is frozen, surveyor should perform survey in same manner as if gas line is under concrete or another hard surface.
- 11.5 Snow cover has little effect on gas migration, unless there is either a frost cap or heavy frost under snow cover.
- 11.6 Walking speed should be adjusted to compensate for adverse weather conditions, thereby ensuring continuous and accurate sampling is being achieved.
- 11.7 Gas Supervisor and Leak Technician are responsible for determining if weather is unacceptable for surveying.

12.0 Leak Detection - Using Gas Detection or FI Unit

- 12.1 If leak surveyor detects possible Class 1 leak, the surveyor will take immediate action to investigate and classify leak with CGI:
 - 12.1.1 Immediate action means surveyor will halt survey and quickly retrieve CGI and probe rod. If surveyor is using an instrument such as the Southern Cross 46 Hawk or Bascom Turner Gas Rover, a CGI is not necessary. The 46 Hawk or Gas Rover can be used to classify leak since they quantify and pinpoint below-ground leaks.
 - 12.1.2 Surveyor shall follow the leak classification procedures contained in [LEAK 1, Section 5.0](#), Leak Detection and Classification.
 - 12.1.3 If leak is classified as Class 1, a contract surveyor will immediately call AIC emergency phone number (1.800.755.5000) to report leak. AIC gas field personnel will contact the Gas Supervisor or AIC designee.
 - 12.1.4 Surveyor will remain at leak location until a qualified employee arrives to take control and make area safe.
 - 12.1.5 Surveyor will initiate and complete Leak Investigation task in ClickMobile.
 - 12.1.6 Surveyor will guard leak location to keep area safe.
- 12.2 If leak surveyor detects gas entering a building, thus, Class 1 leak:
 - 12.2.1 Contract surveyor will immediately call AIC emergency phone number (1.800.755.5000) to report leak. AIC gas field personnel will contact Gas Supervisor or an AIC designee. Surveyor will check for presence of gas at entrance to structure with CGI.
 - 12.2.2 If CGI registers 10% LEL or greater at entrance, the surveyor will immediately notify Gas Supervisor who may initiate [EMER 2.1](#) General and [EMER 2.4.1](#) Dispatched to Indoor Odor or Leak.
 - 12.2.3 Surveyor will notify customer and, if situation is considered hazardous, will evacuate the structure.
 - 12.2.4 Unless surveyor is OQ qualified for inside leak investigation, surveyor will not enter structure.
 - 12.2.5 The surveyor will remain at site until the AIC first responder arrives.

- 12.2.6 Surveyor will initiate and complete Leak Investigation task in ClickMobile.
- 12.2.7 The surveyor will guard structure to keep it safe and not allow anyone to enter.
- 12.2.8 If leak surveyor is OQ qualified for inside and outside leak investigation, procedures in [LEAK 2.1](#) and [LEAK 2.2](#) may be initiated.
- 12.3 If leak surveyor detects gas leak that appears to be non-hazardous, thus, Class 2 or Class 3:
 - 12.3.1 Surveyor may continue with survey until convenient to access vehicle for CGI and probe rod to do full investigation and classification.
 - 12.3.2 Surveyor shall follow the procedures contained in LEAK 1, Section 5.0, Leak Detection and Classification.
 - 12.3.3 Surveyor will initiate and complete Leak Investigation task in ClickMobile, or Leak Surveillance task in ClickMobile if leak is already known.
- 12.4 If leak surveyor detects gas leak on customer owned piping:
 - 12.4.1 Surveyor will immediately call the AIC emergency phone number (1.800.755.5000) to report leak.
 - 12.4.2 An OAS EMGL order will be created, and qualified gas field personnel will be dispatched to leak site.
 - 12.4.3 Surveyor will remain at site until first responder arrives.
 - 12.4.4 Leaks on customer facilities shall be documented in ClickMobile by selecting the Additional Work - Leak on Customer Facilities task.
- 12.5 If leak surveyor detects a gas leak from a valve box or pit that contains a gas facility:
 - 12.5.1 Surveyor will crack the lid slightly, insert CGI probe, and obtain a sustained gas-in-air reading. If surveyor cannot open valve box lid to complete a leak investigation, surveyor will contact local operations Supervisor or his designee for assistance.
 - 12.5.2 Surveyor will check around perimeter of box or pit for gas migration.
 - 12.5.3 Leak will be classified and documented within ClickMobile.

13.0 Remote Methane Leak Detector (RMLD) Survey

- 13.1 RMLD can be utilized in conjunction with Walking Leak Survey and Mobile Leak Survey.
- 13.2 RMLD can detect gas leaks up to 100 feet away.
- 13.3 If walking survey or mobile survey cannot access gas facilities, RMLD may be used to detect possible gas leaks.
- 13.4 Surveyor could use RMLD for above ground piping and facilities.
- 13.5 If there is an indication of possible gas leak, surveyor is required to investigate and classify leak.
- 13.6 Surveyor must be trained and qualified in use of RMLD instrument.

End of Instructions.

Operator Qualification (OQ) Required?

YES

UNCONTROLLED IF PRINTED

1241: Outside Gas Leak Investigation

1261: Walking Gas Leakage Survey

Appendices

NONE.

Attachments

NONE.

Compliance Requirements

49 CFR §192.706 Transmission lines: Leakage surveys.

49 CFR §192.709 Transmission lines: Record keeping.

49 CFR §192.723 Distribution systems: Leakage surveys.

Reference Documents

[QQAL 1 Operator Qualification: Requirements](#)

[QQAL 2.1 Operator Qualification: Covered Task List](#)

[EMER 2.4 Emergency Plan: Gas Field Personnel](#)

[LEAK 1 Leak Management: Requirements](#)

[LEAK 2.1 Leak Management: Indoor Investigations](#)

[LEAK 2.2 Leak Management: Outdoor Investigations](#)

[LEAK 2.3 Leak Management: Leak Investigation Form](#)

[LEAK 2.4 Leak Management: Leak Surveys](#)

[LEAK 2.5 Leak Management: Leak Survey Equipment](#)

[LEAK 3 Leak Management: Forms and Reference Materials](#)

Document Rescission

LEAK 2.09 Leak Management: Leak Surveys - Walking Leak Survey, April 1, 2017.

Revision Notes

Location of Changes	Summary of Changes
Not applicable.	This is a new document.

LEAK MANAGEMENT

October 1, 2020

LEAK 2.7 Mobile Leak Surveys

1.0 Purpose

The mobile leak survey shall be performed with an industry recognized leak survey instrument that has been approved by the Ameren Illinois (AIC) Gas Standards and Procedures work group and performed in a manner to ensure public and employee safety.

2.0 Scope

This document addresses the following:

[3.0 Target Audience](#)[4.0 General](#)[5.0 Mobile Flame Ionization \(FI\) Leak Survey](#)[6.0 Weather Limitations](#)[7.0 Leak Detection](#)[8.0 Remote Methane Leak Detector \(RMLD\) Survey](#)[9.0 Optical Methane Detector \(OMD\) Survey](#)**3.0 Target Audience**

- Gas Field Personnel.
- Gas Supervisors.
- Gas Tech Services Personnel.
- Gas Tech Services Supervisors.
- Leak Surveyors.

4.0 General

- 4.1 A mobile survey can be performed in areas where a mobile unit is able to travel over transmission pipeline, high pressure distribution, distribution main, or possibly distribution service lines.
- 4.2 In areas with vegetative cover, the mobile unit should straddle pipeline.
- 4.3 In area where gas mains are located under concrete surface, mobile unit's sampling and sensing devices must be situated so they pass over the seam between pavement and curb plus back of curb.
- 4.4 A walking leak survey is to be used in conjunction with mobile leak survey where concrete or hard surface exists from road to the structures.
- 4.5 Walking leak survey is required for sampling along edges of buildings and other areas where gas could be venting.
- 4.6 The mobile leak survey method has limited application due to accessibility with a mobile unit. Surveyor will be required to walk portions with Gas Detection Instrument or FI Unit to complete the survey.

5.0 Mobile Flame Ionization (FI) Leak Survey

- 5.1 A standard FI unit is mounted on a motorized vehicle such as truck, car, or ATV. See [LEAK 2.5](#) for equipment particulars.

UNCONTROLLED IF PRINTED

- 5.2 Follow manufacturer's operating instructions on FI unit for start-up procedures, required maintenance (e.g., filter changes), daily operational check, and operating instructions. See [LEAK 3](#).
- 5.3 If FI unit is being utilized on daily basis for leak survey activity, the unit should be checked at end of day's activity to verify it is still operating properly.

6.0 Weather Limitations

- 6.1 Gas detector design or adverse conditions may limit the use of Mobile FI Leak Survey.
- 6.2 Adverse conditions that may affect venting of subsurface gas leaks include:
 - 6.2.1 Moisture, rain, or wet vegetation.
 - 6.2.2 Heavy frost layer.
 - 6.2.3 Ice and snow cover.
 - 6.2.4 High or gusting winds.
- 6.3 Gas Supervisor or Contract Leak Technician is responsible to determine if weather is acceptable for mobile leak surveying.
- 6.4 Driving speed should be adjusted to compensate for adverse weather conditions, thereby ensuring that continuous / accurate sampling is achieved.

7.0 Leak Detection

- 7.1 If mobile unit detects a possible gas leak, surveyor will quickly park the mobile unit.
- 7.2 Surveyor will take immediate action to investigate and classify leak with CGI in accordance with [LEAK 1](#).
- 7.3 If leak is classified Class 1, surveyor will follow procedures listed under Walking Leak Survey, [LEAK 2.6, Section 12.0](#), Leak Detection.
 - 7.3.1 Contract surveyor will call the AIC emergency phone number (1.800.755.5000) to report leak. AIC gas field personnel will contact Gas Supervisor or AIC designee.
 - 7.3.2 Surveyor will remain at leak location until a qualified employee arrives to take control and make area safe.
 - 7.3.3 Surveyor will complete Leak Investigation task in ClickMobile.
- 7.4 If leak surveyor detects gas leak that appears to be non-hazardous, thus, Class 2 or Class 3:
 - 7.4.1 Surveyor may continue with survey until convenient to access vehicle for probe rod and CGI to do full investigation and classification.
 - 7.4.2 Surveyor shall follow the procedures contained in [LEAK 1, Section 5.0](#), Leak Detection and Classification.
 - 7.4.3 Surveyor will initiate Leak Investigation task in ClickMobile, or Leak Surveillance task in ClickMobile if leak is already known.

8.0 Remote Methane Leak Detector (RMLD) Survey

- 8.1 RMLD can be used in conjunction with walking leak survey and mobile leak survey.
- 8.2 RMLD can detect gas leaks up to 100 feet away.

- 8.3 If walking survey or mobile survey cannot access gas facilities, RMLD may be used to detect possible gas leaks.
- 8.4 Surveyor could use RMLD for aboveground piping and facilities.
- 8.5 If there is an indication of possible gas leak, surveyor is required to investigate and classify leak.
- 8.6 Surveyor must be trained and qualified in use of RMLD instrument.

9.0 Optical Methane Detector (OMD) Survey

- 9.1 OMD can be used in conjunction with Walking Leak Survey.
- 9.2 OMD can only be used where the OMD can straddle the buried gas facility being surveyed.
- 9.3 Ground conditions over buried gas facility must allow natural gas to vent.
- 9.4 Where gas mains are located under concrete surface, see [Section 4.0](#).
- 9.5 If mobile unit detects a possible gas leak, surveyor will quickly park mobile unit.
- 9.6 The surveyor will take immediate action to investigate and classify leak with CGI in accordance with [LEAK 1](#).
- 9.7 If leak is classified Class 1, surveyor will follow procedures listed under Walking Leak Survey, [LEAK 2.6, Section 12.0](#), Leak Detection.
 - 9.7.1 Contract surveyor will immediately call AIC emergency phone number (1.800.755.5000) to report leak. AIC gas field personnel will contact Gas Supervisor or AIC designee.
 - 9.7.2 Surveyor will remain at leak location until a qualified employee arrives to take control and make area safe.
 - 9.7.3 Surveyor will initiate Leak Investigation task in ClickMobile.
- 9.8 If leak appears to be non-hazardous, thus, Class 2 or Class 3:
 - 9.8.1 Surveyor may continue with survey until convenient to access vehicle for probe rod and CGI to do full investigation and classification.
 - 9.8.2 Surveyor shall follow procedures contained in [LEAK 1, Section 5.0](#), Leak Detection and Classification.
 - 9.8.3 Surveyor will initiate Leak Investigation task in ClickMobile, or a Leak Surveillance task if leak is already known.
- 9.9 Mobile leak survey method has a limited application due to accessibility with a mobile unit. Surveyor will be required to walk portions with Gas Detection Instrument or FI Unit to complete survey.

End of Instructions.

Operator Qualification (OQ) Required?

YES

1241: Outside Gas Leak Investigation

1271: Mobile Gas Leakage Survey - Flame Ionization

UNCONTROLLED IF PRINTED

1281: Mobile Gas Leakage Survey - Optical Methane

Appendices

NONE.

Attachments

NONE.

Compliance Requirements

- 49 CFR §192.706 Transmission lines: Leakage surveys.
- 49 CFR §192.709 Transmission lines: Record keeping.
- 49 CFR §192.723 Distribution systems: Leakage surveys.

Reference Documents

- [QQAL 1 Operator Qualification: Requirements](#)
- [QQAL 2.01 Operator Qualification: Covered Task List](#)
- [LEAK 1 Leak Management: Requirements](#)
- [LEAK 2.2 Leak Management: Outdoor Investigations](#)
- [LEAK 2.3 Leak Management: Leak Investigation Form](#)
- [LEAK 2.4 Leak Management: Leak Surveys](#)
- [LEAK 2.5 Leak Management: Leak Survey Equipment](#)
- [LEAK 2.6 Leak Management: Walking Leak Survey](#)

Document Rescission

LEAK 2.10 Leak Management: Leak Surveys - Mobile Leak Survey, December 1, 2014.

Revision Notes

Location of Changes	Summary of Changes
Not applicable.	This is a new document.

LEAK MANAGEMENT

October 1, 2022

LEAK 2.8 Advanced Mobile Leak Survey

1.0 Purpose

Advanced Mobile Leak Survey (AMLS) shall be performed with an industry recognized instrument utilizing Laser Spectroscopy. AMLS shall be performed with an instrument approved by the Ameren Illinois (AIC) Gas Standards and Procedures work group in a manner to ensure public and employee safety.

2.0 Scope

This document addresses the following:

[3.0 Target Audience](#)[4.0 General](#)[5.0 Data Collection Driving Protocol](#)[6.0 Indication Investigation](#)[7.0 Survey Gaps](#)**3.0 Target Audience**

- Gas Field Personnel.
- Gas Supervisors.
- Leak Surveyors

4.0 General

4.1 An AMLS consists of three separate activities. All three activities listed below shall be completed prior to the completion of the leak survey for any given survey route.

4.1.1 Data Collection Drive

4.1.1.1 The Advanced Mobile Leak Detection (AMLD) unit is driven along survey routes to collect atmospheric conditions such as: methane concentration, wind speed and direction, and GPS data.

4.1.1.2 After completion of data collection, the unit provides a report with potential leak indication areas.

4.1.2 Indication Investigation

4.1.2.1 Qualified field personnel shall conduct leak investigations within the search area defined by the AMLD unit reports.

4.1.2.2 Field personnel shall follow procedures defined in [LEAK 2.2 Outdoor Investigation](#).

4.1.3 Survey Gaps

4.1.3.1 If the AMLD unit does not cover the entire survey area during the data collection activity, then a walking survey shall be completed on the assets that have not been surveyed. See [LEAK 2.6 Walking Leak Surveys](#)

UNCONTROLLED IF PRINTED

5.0 Data Collection Driving Protocol

- 5.1 Follow the manufacturer's user manual for start-up and operating guidelines. User manuals can be found in [LEAK 3](#).
- 5.2 Weather, traffic, and vehicle speed may affect analyzer performance, follow manufacturer's recommendations when operating.
- 5.3 All accessible roads within the survey area should be driven on each side (unless single lane, one way) on two separate nights for a minimum of 4 passes.
 - 5.3.1 If possible, drive accessible areas where commercial offices, business centers, industrial parks, alleys, etc. are located. Try to maximize coverage area.
- 5.4 Driving operations should occur between sunset and sunrise unless otherwise approved by engineering or supervision.
- 5.5 If the instrument alarm indicates an error, survey data collection should stop until error is resolved.
 - 5.5.1 If the analyzer alarms due to a large presence of methane, the driver may stop the vehicle and stop or pause the analyzer.
 - 5.5.1.1 If the driver is qualified for Outside Gas Leak Investigation, then they may conduct an immediate leak investigation.
 - 5.5.1.2 If the driver is not qualified for Outside Gas Leak Investigation, then they may call in the potential leak and wait for gas field personnel to arrive.
- 5.6 Following the data collection, the AMLD unit will generate reports that detail indications of possible methane emissions. The report will require a review to determine the integrity of the data, if additional drives are required, or if the survey must be completed by another approved leak survey method.

6.0 Indication Investigation

- 6.1 The indications identified on an approved AMLD unit report shall be investigated to determine if there is a natural gas leak. Reference [LEAK 2.2 Outdoor Investigation](#).
- 6.2 All indications identified by the AMLD unit shall be investigated, including "indeterminate" and "biogas" emission indications.
- 6.3 Indications should be investigated during daytime hours following the completion of the final data collection drive. All indications shall be investigated prior to leak survey compliance date.
- 6.4 The radius of the investigation area should extend approximately 50' beyond the indication area. The investigation area may need to extend beyond the 50' radius if further investigation is needed.

7.0 Survey Gaps

- 7.1 Because the AMLS relies on wind speed and direction, the data collection phase might not cover/capture all of the assets within the survey route.
- 7.2 Any assets within the leak survey route that have not been covered will need to have additional drive passes or will need to be surveyed by other approved methods prior to the completion of the survey.

End of Instructions.

Operator Qualification (OQ) Required?

YES

1241: Outside Gas Leak Investigation

1261: Walking Gas Leakage Survey

A004: Advanced Mobile Gas Leakage Survey - Laser Spectroscopy

Appendices

NONE.

Attachments

NONE.

Compliance Requirements

49 CFR §192.706 Transmission lines: Leakage surveys.

49 CFR §192.709 Transmission lines: Record keeping.

49 CFR §192.723 Distribution systems: Leakage surveys.

Reference Documents

[LEAK 2.2 Leak Management: Outdoor Investigations](#)

[LEAK 2.6 Leak Management: Walking Leak Surveys](#)

[LEAK 3 Leak Management: Forms and Equipment References](#)

Document Rescission

NONE

Revision Notes

Location of Changes	Summary of Changes
Not applicable.	This is a new document.

LEAK MANAGEMENT

October 1, 2022

LEAK 2.9 Survey Maps and Records

1.0 Purpose

This document describes map and record requirements accompanying leak management by Ameren Illinois (AIC), all to ensure proper and timely documentation for any natural-gas leakage as surveyed, investigated, classified, monitored, repaired, and reported in accordance with applicable federal / state regulations.

2.0 Scope

This document addresses the following:

[3.0 Target Audience](#)[4.0 General](#)[5.0 Maps and Records](#)**3.0 Target Audience**

- Gas Field Personnel.
- Gas Supervisors.
- Gas Engineers.
- Gas Tech Services Personnel.
- Gas Tech Services Supervisors.
- Leak Surveyors.

4.0 General

- 4.1 In addition to performing a leak survey, the gas field personnel or contract leak technicians are required to report any deficiencies observed while conducting any leak survey within the AIC system. Deficiencies are documented in ClickMobile and are tracked in Maximo.
- 4.2 Leak survey deficiencies include:
 - 4.2.1 Atmospheric corrosion on aboveground facilities.
 - 4.2.2 Disbonded coating on risers at regulator stations, valving stations, meter sets.
 - 4.2.3 Inaccessible facilities.
 - 4.2.4 Facilities that need painting.
 - 4.2.5 Leak on customer facilities.
 - 4.2.6 Vent screen missing or missing spring cap.
 - 4.2.7 Electric ground wires attached to gas facilities.
 - 4.2.8 Items or material inappropriately attached to meter set.
 - 4.2.9 Inaccessible meter valves.
 - 4.2.10 Aboveground plastic pipe.
 - 4.2.11 Exposed mains or service lines.
- 4.3 Deficiencies and leaks found on AIC facilities are to be reported each day in ClickMobile.
- 4.4 Reported deficiencies are tracked in Maximo.

UNCONTROLLED IF PRINTED

5.0 Maps and Records (49 CFR §192.709, §192.481)

- 5.1 Electronic maps in ClickMobile will be used for all transmission, high pressure distribution, and distribution leak surveys.
- 5.2 Annual leak surveys performed by Gas Technical Services personnel inside fenced areas are documented in ClickMobile.
- 5.3 Leak surveyors will record each day's survey by "lassoing" completed sections of pipeline and facilities that were leak surveyed in ClickMobile.
- 5.4 Survey will be reviewed for completeness by appropriate Gas Engineer or Gas Supervisor. Corrections, revisions, or updates to maps will be submitted to personnel responsible for maintaining and updating system maps.
- 5.5 *Transmission* leak survey maps and records will be *maintained* in Maximo for *minimum of 5 years*.
- 5.6 *All distribution* leak survey maps and records will be *maintained* in Maximo for a *minimum of 6 years*.
 - 5.6.1 If atmospheric corrosion monitoring is performed in conjunction with the distribution leak surveys, records shall be maintained in Maximo of at least the two most recent atmospheric corrosion inspections.
- 5.7 Residential Yardline and Inside Meter Leak Survey Records:
 - 5.7.1 Gas Engineer or Gas Supervisor maintains location of each yardline to be surveyed in Maximo (or may keep such on spreadsheets).
 1. Surveyor signs (or initials) and dates when each location is surveyed.
 2. Surveyor will note if yardline has been eliminated so the spreadsheet can be updated before next survey.
 3. If during survey, surveyor finds a yardline that is not on spreadsheet, it will be added for spreadsheet update.
 4. When entire survey is completed, surveyor will complete Yardline Survey task in ClickMobile.
 - 5.7.2 Gas Engineer or Gas Supervisor maintains location of each inside gas meter outside the Business District in Maximo (or may keep on spreadsheet).
 1. Surveyor signs (or initials) and dates when each location is surveyed.
 2. Surveyor will note if inside meter has been eliminated so spreadsheet can be updated before next survey.
 3. When entire survey is completed, surveyor will complete Inside Meter Survey task in ClickMobile.
 - 5.7.3 Completed surveys and associated records will be maintained in Maximo.
 - 5.7.4 Leak records for both Residential Yardline and Inside Meter Leak Surveys will be *maintained for a minimum of 6 years*.

End of Instructions.

Operator Qualification (OQ) Required?

YES

UNCONTROLLED IF PRINTED

- 1231: Inside Gas Leak Investigation
- 1241: Outside Gas Leak Investigation
- 1271: Mobile Gas Leakage Survey - Flame Ionization
- 1281: Mobile Gas Leakage Survey - Optical Methane

Appendices

NONE.

Attachments

NONE.

Compliance Requirements

- 49 CFR §192.706 Transmission lines: Leakage surveys.
- 49 CFR §192.709 Transmission lines: Record keeping.
- 49 CFR §192.723 Distribution systems: Leakage surveys.

Reference Documents

- [QQAL 1 Operator Qualification: Requirements](#)
- [QQAL 2.01 Operator Qualification: Covered Task List](#)
- [LEAK 1 Leak Management: Requirements](#)
- [LEAK 2.1 Leak Management: Indoor Investigations](#)
- [LEAK 2.2 Leak Management: Outdoor Investigations](#)
- [LEAK 2.3 Leak Management: Leak Investigation Form](#)
- [LEAK 2.4 Leak Management: Leak Surveys](#)
- [LEAK 2.6 Leak Management: Walking Leak Surveys](#)
- [LEAK 2.7 Leak Management: Mobile Leak Surveys](#)

Document Rescission

LEAK 2.8 Leak Management – Leak Surveys – Records and Maps, December 15, 2021

Revision Notes

Location of Changes	Summary of Changes
HEADER	Changed to LEAK 2.9

LEAK MANAGEMENT

April 1, 2023

LEAK 3 Forms and Reference Materials

Click on the links below to open the documents.

Forms

1. [Instrument Calibration Record Form.](#)
2. [Leak Investigation Form \(Rev. 4/01/21\)](#)
3. [ClickMobile Leak Investigation Form](#)

References

1. [ABB Ability Mobile Gas Leak Detection System \(MobileGuard\)](#)
2. [Bascom Turner Gas Rover Operation Manual \(Updated\)](#)
3. [Bascom Turner Gas Sentry Operation Manual](#)
4. [Heath Detecto-Pak 4 User's Manual \(Updated\)](#)
5. [Heath Gasurveyor 500 Manual \(Updated\)](#)
6. [Heath Gasurveyor 700 User's Manual \(Updated\)](#)
7. [Inficon Irwin Operating Instructions](#)
8. [Sensit GAS TRAC LZ 30 Instruction Manual](#)
9. [Sensit Gold CGI Instruction Manual \(Revision 12-15-2017\)](#)
10. [Sensit Gold G2 Instruction Manual \(Revision 06-20-2020\)](#)
11. [Sensit HXG-3 Instruction Manual \(Updated\)](#)
12. [Sensit IRED Manual \(Revision 02-08-2021\)](#)
13. [Sensit IRED Quick Start Instructions](#)
14. [Southern Cross 46 Hawk Manual](#)
15. [Southern Cross Flame Pack Series 400 Operational Service Manual](#)

End of Section.

Document Rescission

LEAK 3 Leak Management -- Forms and Reference Materials, May 15, 2022.

Revision Notes

Location of Changes	Summary of Changes
---------------------	--------------------

UNCONTROLLED IF PRINTED

<p>Reference Materials</p>	<p>New – Inficon IRwin Operating Instructions</p> <p>Renamed: ABB Ability Mobile Gas Leak Detection System (MobileGuard)</p> <p>Updated Manuals:</p> <p>Bascom Turner Gas Rover Operating Manual</p> <p>Heath Detecto-Pak 4 User's Manual</p> <p>Heath Gasurveyor 500 User Handbook</p> <p>Heath Gasurveyor 700 User's Guide</p> <p>Sensit HXG-3 Instruction Manual</p> <p>Removed:</p> <p>Gas-Trac Instrument Manual</p> <p>Heath EI-4 Ethane Identifier Manual</p> <p> Heath EI-5 Ethane Identifier User Manual</p> <p>Heath GT Series User Handbook</p> <p>Heath OMD User's Manual</p> <p>Heath RMLD User's Manual</p> <p>Southern Cross All Terrain MLD Kit Manual</p> <p>iTrans 2 User Manual</p> <p>MBW Vapor Extraction Unit Operator Safety and Service Manual</p>
----------------------------	---

LOCT-Locating

LOCATING

December 1, 2020

LOCT 0 Table of Contents

LOCT 1 Locating: Methods

Section 1.0 Purpose

Section 2.0 Scope

Section 3.0 Target Audience

Section 4.0 General

Section 5.0 Locating Methods

Section 6.0 Instrument Setup Procedure

Section 7.0 Electronic Locating

Operator Qualification (OQ)

Appendices

Appendix A - Locating Equipment

Appendix B - Locate Markings

Compliance Requirements

Reference Documents

Document Rescission

LOCT 2 Locating: Forms and Reference Materials

Reference Documents

Document Rescission

End Table of Contents.

Document Rescission

LOCT 0 Locating: Table of Contents, October 1, 2020.

Revision Notes

Location of Changes	Summary of Changes
LOCT2	Made format consistent with other Forms and Reference Materials documents

UNCONTROLLED IF PRINTED

LOCATING

December 1, 2020

LOCT 1 Methods

1.0 Purpose

This section provides an overview of the different methods used by Ameren Illinois (AIC), or its contractor, for locating underground natural-gas facilities. This is to ensure that such pipeline facilities are properly located and identified to allow safe excavation activity and thus maintain safety for all parties and the public.

2.0 Scope

This document addresses the following:

[3.0 Target Audience](#)[4.0 General](#)[5.0 Locating Methods](#)[6.0 Instrument Setup Procedure](#)[7.0 Electronic Locating](#)

Appendices

[Appendix A - Locating Equipment](#)[Appendix B - Locate Markings](#)**3.0 Target Audience**

- Gas Field Personnel
- Gas Supervisors
- Damage Prevention Personnel

4.0 General

- 4.1 Locating is the process of finding and marking the location of underground facilities based on identifying any buried conductive metal, such as pipeline or tracer wire. These underground facilities are located prior to excavation activities and in response to requests received through the JULIE system.
- 4.2 Each JULIE member is responsible for having their own underground facilities marked with paint or flags.
- 4.3 AIC has adopted a modified version of the *Illinois Statewide Marking Guidelines for Underground Line Owners* as published by the JULIE One-Call System. See Appendix B for marking paint colors and flags.
- 4.4 AIC contracts with a third party to have AIC's buried facilities marked in response to JULIE requests. The AIC Damage Prevention group is responsible for monitoring the performance of contracted party.

5.0 Locating Methods

- 5.1 Visual

5.1.1 Search for pedestals or risers which might indicate an underground cable or pipe nearby.

5.1.2 Report evidence of underground utilities to JULIE if no markings exist.

5.2 Probe

5.2.1 A probe is inserted in ground to locate a line by feel.

5.2.2 Probing is time consuming, impractical for deep facilities, and may damage a facility's coating.

5.3 Electronic

5.3.1 An electronic device is used to detect underground facilities by utilizing either Radio Frequency (RF) or Audio Frequency (AF).

5.4 Measurement

5.4.1 Location is marked by using dimensions indicated on existing AIC records.

5.4.2 Use this method only when facilities cannot be located electronically.

5.5 Excavate

5.5.1 Excavating is done to expose the underground facility.

5.5.2 Excavation within the tolerance zone requires extra care and precaution. Refer to AIC Field Safety Manual, Section 33.4 Work within the Tolerance Zone.

5.5.3 Methods include hand excavation, vacuum excavation, and visually inspecting the excavation while in progress until clear of existing facility.

5.5.4 Excavating is most accurate method but requires extreme caution.

6.0 Instrument Setup Procedure

6.1 Test transmitter battery.

6.2 Turn transmitter "On."

6.3 Test receiver battery.

6.4 Turn receiver "On."

6.5 Select locating method (i.e., inductive, conductive).

For the rest of the tuning procedure, hold the instrument above the ground at an even height.

6.6 Select transmitter location.

6.7 Adjust receiver for tone.

6.8 Do not "swing" the receiver. Keep it low to the ground and hold it either vertically (peak) or horizontally (null).

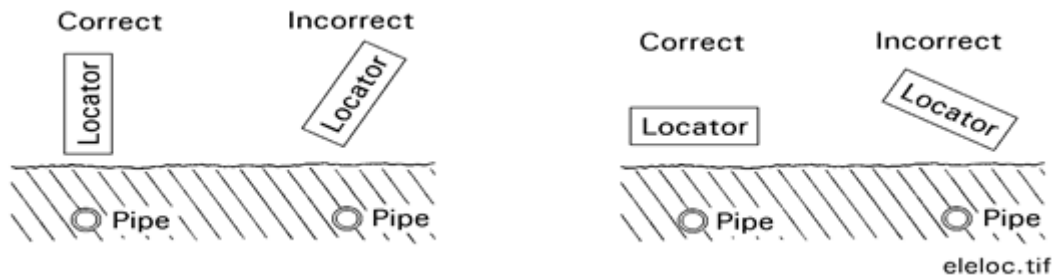

Maximum signals are obtained when the pipe is crossed at right angles. When locating service lines, walk parallel to the curb. When locating a main, walk perpendicular to the curb.

7.0 Electronic Locating

7.1 General

- 7.1.1 Preferred method of electronic locating is to actively apply signal onto pipeline facility using a direct connection.
- 7.1.2 If direct connection is not possible, use of induction clamp (coupler) is next most effective method of applying locate signal onto target conductor. Using an induction clamp is not as effective at transmitting a signal as direct connection. It can only be used within certain frequency ranges and must use a higher power output.
- 7.1.3 Least preferred method is induction or broadcast mode on a transmitter. This usually results in a weak signal that can "bleed over" to any conductor in the area.
- 7.1.4 Both peak and null methods can be used in conductive and inductive locating.

7.2 Conductive Method

Signal is produced on underground facility through a wire lead attached to facility and to locator transmitter.

- 7.2.1 Plug direct-connect transmitter cable into transmitter output jack.
- 7.2.2 Connect red clip to conductor (pipe, valve, etc.).
- 7.2.3 Connect black clip to ground rod. Set the ground rod in good soil several feet away and perpendicular to facility path.

Never ground to water pipe or other services in the area as returning signal may create an out-of-phase condition which will mislead the locate.

- 7.2.4 Locate and mark the facility.

Do not connect the two clips to one another with the switch on. This will "short-circuit" transmitter's output circuit.

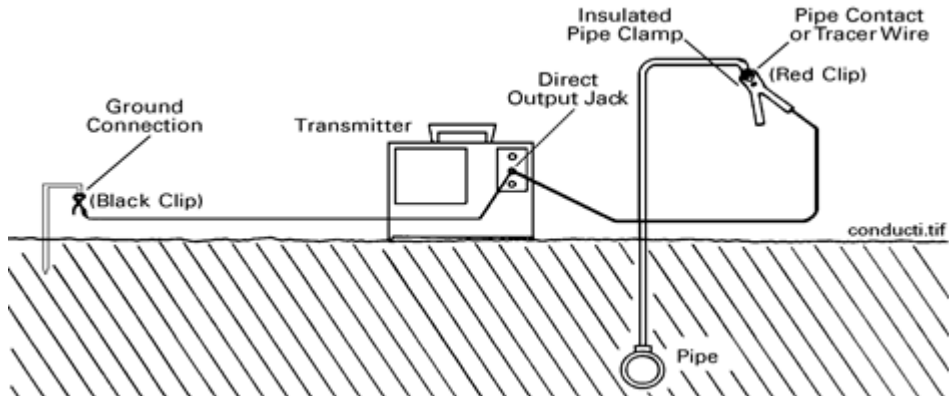

7.3 Inductive Method

7.3.1 General: Signal is produced on underground facility through the ground from transmitter to receiver. Locating equipment is not attached to either the underground facility or locator transmitter.

Exercise care when utilizing inductive methods that only the target facility is marked.

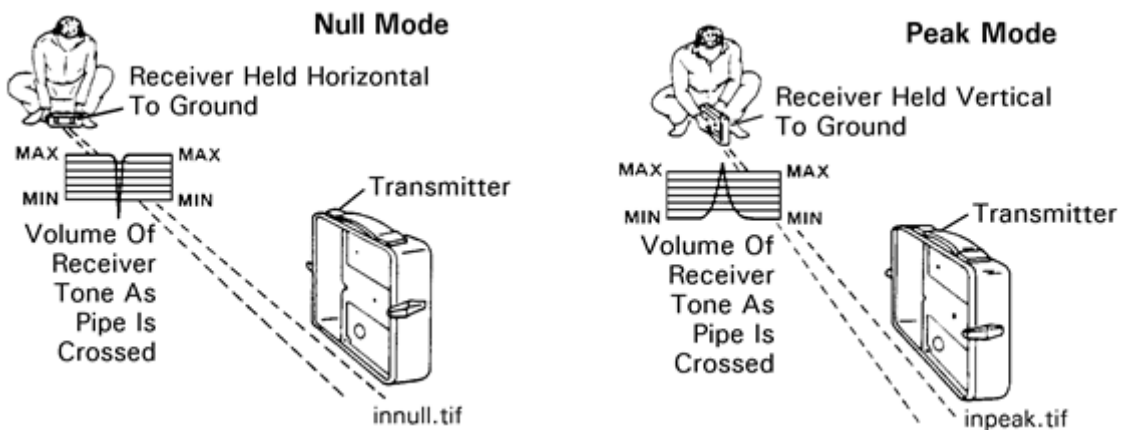

If other underground or overhead utilities (such as telephone, CATV, and water pipes) are in the same area, use conductive method or inductive coupling.

1. Set transmitter on ground near the facility.
2. Locate and mark facility. Maintain appropriate distance (usually 50 - 75 feet) between receiver and transmitter to avoid air-to-air signal.

7.3.2 Inductive Coupling (Units with Capability)

1. The inductive method can only be performed when transmitter is in RF mode.
2. The coupler puts tone selectively on facility by clamping around it. While this eliminates need to disconnect bonds or make direct connection to a conductor, it requires direct access to the underground facility.

7.3.3 Inductive, Off-Handle without Partner

1. Place transmitter on ground over and parallel to pipe to be traced. A radio frequency should be detected as receiver is swung across the pipe path.
2. Operating Suggestions
 - 2 a. If pipe is exposed, do not set transmitter directly on pipe, or within 1 foot of any mass of metal. This will overload transmitter and cause a frequency shift or stop transmitter's oscillation.
 - 2 b. For long tracing runs, the transmitter can be moved up (or forward) to reenergize the pipe when the signal becomes weak.
 - 2 c. Be alert to air-to-air signals when working close to the transmitter. Either offset transmitter 10 feet or carry it to another point to energize pipe.
 - 2 d. Signals impressed on a pipe at one point can be transferred to another pipe through a common point and cause erroneous readings. *Examples:* It is possible signal may carry through the gas piping back to gas-fired water heater where it is mechanically (and electrically) common with the water pipe. Also, it is possible signal can be carried on the water service or water main. Be aware of these possibilities for false signals.

7.3.4 Inductive, Off-Handle with Partner

1. One person carries transmitter and another the receiver. Keep boxes in line with each other and a constant distance between the equipment. This method is extremely useful when the approximate location of main is unknown. When both operators are directly above the pipe, signal will be at its maximum.

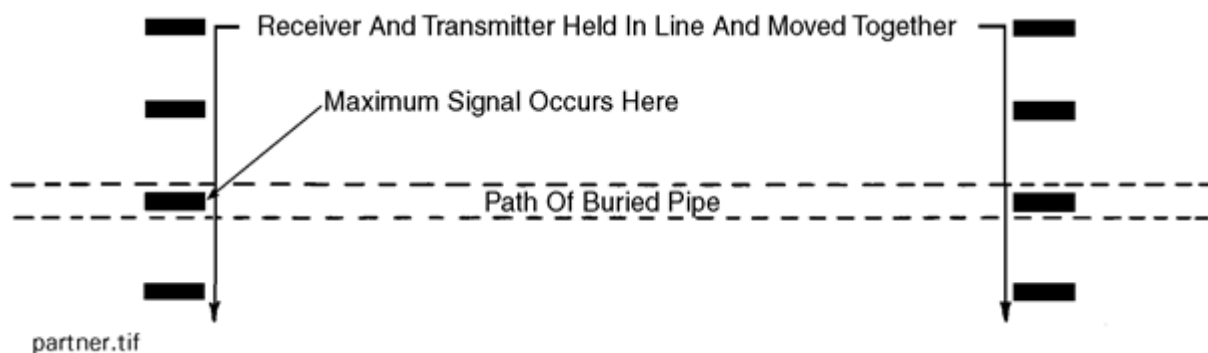

7.4 Depth Estimation by Triangulation Method

7.4.1 Mark the location of the facility.

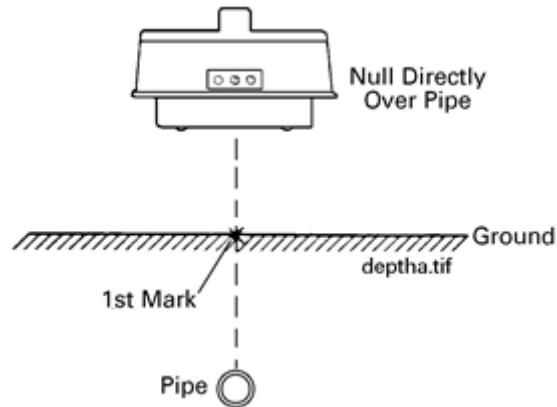

7.4.2 Place receiver at a location parallel to main and tilt the bottom at 45° angle relative to ground. Maintaining the 45° angle, move to side of and perpendicular to pipe path until receiver again indicates a null. Mark ground at point directly below center of the receiver. The distance between first mark and second mark *minus* the height of receiver above ground equals pipeline depth below first mark. See diagram below. Again, subtract the height above ground from the horizontal distance to calculate pipe depth.

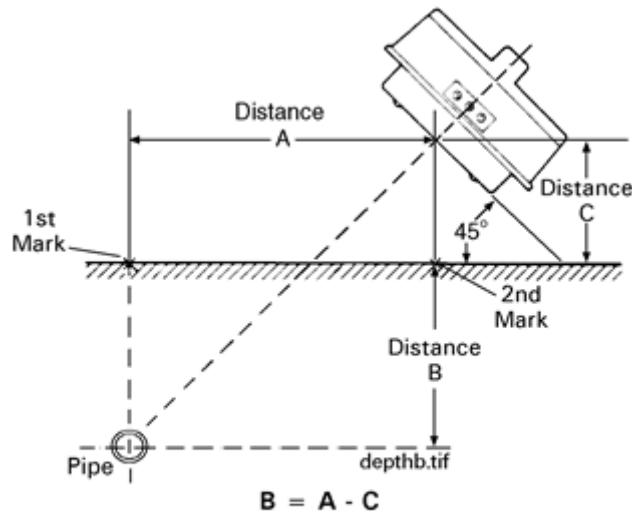

$$B = A - C$$

Where:

- A = Horizontal distance from 1st mark
- B = Pipe depth
- C = Distance from ground to center of receiver

1. AIC does not provide outside parties with depth measurements. Various locators can provide depth estimation by other methods. For AIC use, see operator's manual for specific make and model of locator used to estimate facility depth.
2. Depth measurements with current technology and locating tools are not exact and are frequently inaccurate in areas with multiple underground facilities or even nearby conductive objects, such as a metal shed, due to the inability of equipment to distinguish multiple objects.

7.5 Locating a Lateral or Branch

To locate a service or branch lateral off the main line:

- 7.5.1 Energize, locate, and mark the main line using a suitable transmitter application.
- 7.5.2 With receiver in operating mode, move approximately 5' away from the main. Slowly sweep parallel to main line with receiver positioned perpendicular to main line as shown below.
- 7.5.3 Follow visual and audio indications. Use null method to pinpoint the lateral.

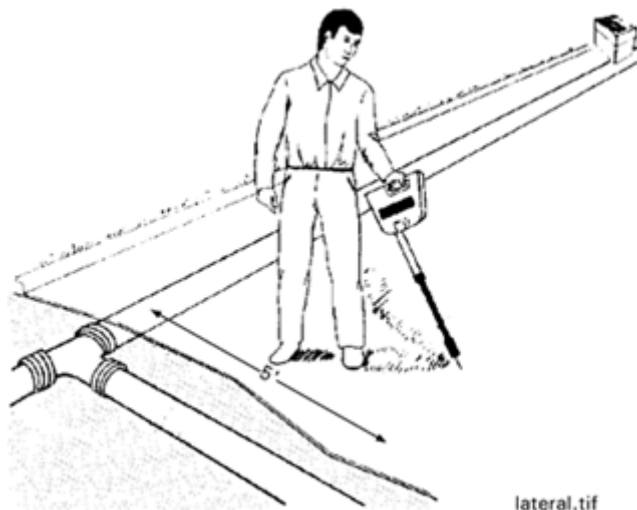

7.6 Locating a Dead End

- 7.6.1 Trace along the line. When receiver crosses over a dead end, audio signal should drop. Stop and slowly move receiver in a 180° sweep to verify signal loss was the end, not a bend. If no other signal is detected, retrace initial steps. A distinct tone change indicates end of the conductor. Perform this operation slowly and carefully.

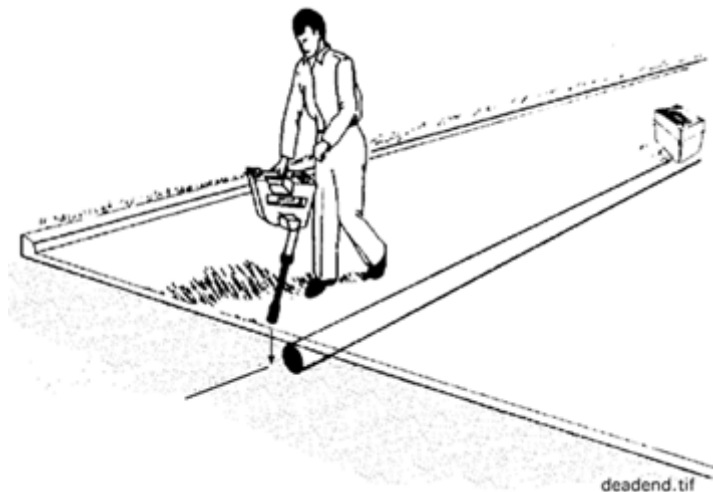

7.7 Locating a Bend

- 7.7.1 As operator approaches the bend area, tone should change. Stop and sweep receiver 180° along ground to determine direction of the bend. Locate pipe in both directions toward bend and mark bend where lines intersect. There may be a confused signal area at the exact bend point.

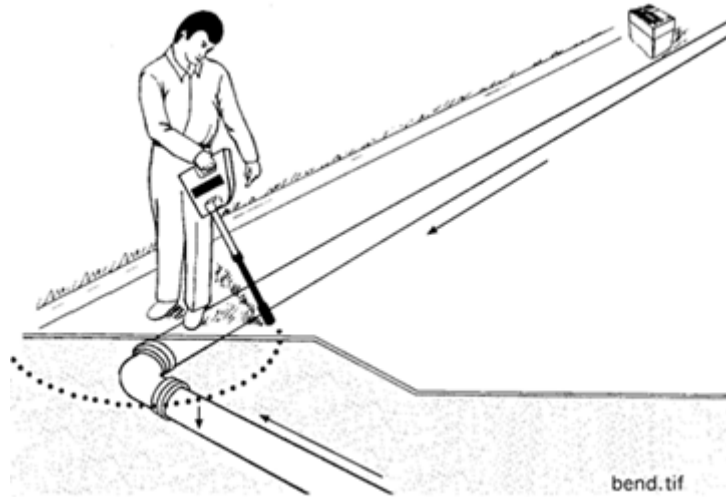

End of Instructions.

Operator Qualification (OQ) Required?

YES

- 0301 Manually Opening and Closing Valves
- 1201 Temporary Isolation of Service Lines and Service Discontinuance
- 1291 Locate Underground Pipelines
- 1301 Install and Maintain Pipeline Markers
- 1311 Inspect Pipeline Surface Conditions - Patrol Right of Way or Easement
- 1321 Damage Prevention During Excavation Activities by or on Behalf of The Operator
- 1331 Damage Prevention During Third Party Excavation or Encroachment Activities as Determined Necessary by Operator

Appendices

[Appendix A - Locating Equipment](#)

[Appendix B - Locate Markings](#)

Attachments

NONE.

Compliance Requirements

- 49 CFR §192.614: Damage prevention program
- 49 CFR §192.616: Public awareness
- 49 CFR §192.707: Line markers for mains and transmission lines
- 49 CFR §192.805: Qualification program

(See reference documents)

Reference Documents

UNCONTROLLED IF PRINTED

[QQAL 1 Operator Qualification: Requirements](#)

[QQAL 2.01 Operator Qualification: Covered Task List](#)

[LOCT 2 Locating: Forms and Reference Materials](#)

The Illinois Underground Utility Facilities Damage Prevention Act - available online [here](#).

Illinois Statewide Marking Guidelines for Underground Line Owners, published by the JULIE One-Call System - available online [here](#).

JULIE Excavator Handbook - available online [here](#).

AIC Field Safety Manual, Section 33.4

Document Rescission

LOCT 1 Locating: Methods, October 1, 2020

Revision Notes

Location of Changes	Summary of Changes
Paragraph 5.5.2	Added reference to AIC Field Safety Manual, Section 33.4 Work Within the Tolerance Zone
Reference Documents	Added AIC Field Safety Manual, Section 33.4

Appendix A - Equipment

A-1. Locating Equipment

The following items may be used in locating and marking underground facilities:

- Electronic locators (see Section A-2 below).
- Tape measure or wheel.
- Spray paint (see [Appendix B Section B-2](#)).
- Flags (see [Appendix B Section B-3](#)).
- Maps and/or records.

A-2. Electronic Locators

The following locators are used by Ameren Illinois (AIC). Other electronic locators may be used upon approval:

Locator	Model	Inductive	Conductive
Delcon	4900A		X
Ditch Witch	950 R/T	X	X
Dynatel	500A	X	X
Dynatel	500 A/P	X	X
Dynatel	2210	X	X
Dynatel	2550-2573		
Dynatel	4420L		

UNCONTROLLED IF PRINTED

Fisher	TW-6	X	X
Fisher	TW 82	X	X
Goldak	902	X	X
Goldak/UDSEC	TR-5A	X	X
Heath	LS-800	X	X
Heath	Sure Lock	X	X
Jameson	Line Tracer		
MADE	Gas Tracker		X
Metrotech	480B	X	X
Metrotech	810	X	X
Metrotech	850	X	X
Metrotech	9860	X	X
Metrotech	9890	X	X
Metrotech	9860XT	X	X
Metrotech	9890XT	X	X
Nilson	715		X
Pipehorn	100	X	X
Pipehorn	500	X	X
Pipehorn	800-HL	X	X
Radiodetection	RD4000	X	X
Radiodetection	RD7000	X	X
Radiodetection	RD8000	X	X
Rycom	8860	X	X
Rycom	8875	X	X
Subsite	950	X	X
Tinker & Razor	MKIV	X	X
Verifier	G2	X	X
Vivax	vLocPro	X	X
Vivax	vLocPro 2	X	X

NOTE: See the manufacturer's instruction manual for detailed instructions on specific use for each locator. See [LOCT 2](#).

Appendix B - Locate Markings

B-1. Utility Marking Colors

B-1.1 The following APWA Uniform Color Code shows the colors each utility will use when staking, painting, and/or flagging the location of a buried utility facility:

Identification Color	Utility/Type of Product
Yellow	Gas, Oil, Steam, Petroleum

Red	Electric
Blue	Potable Water
Orange	Communication, Telephone, TV
Green	Sewer and Drain Lines
Purple	Reclaimed Water, Irrigation, Slurry Lines
Pink	Temporary Survey
White (Black on snow)	Proposed Area of Excavation

B-2. Marking Paint

B-2.1 Marking paint should be biodegradable.

B-2.2 Only marking paints designed to spray from the inverted position should be used.

B-2.3 A line should be sprayed on the surface above the underground gas line as follows:

B-2.3.1 Approximately 12 inches long and 2 inches wide.

B-2.3.2 Length of each mark should be approximately 12 - 18 inches.

B-2.3.3 Distance between marks depends on site conditions but should be no greater than 20 feet.

B-2.3.4 End marks should contain arrows if line continues.

B-2.3.5 Company identification should be painted at reasonable intervals to allow quick identification.

B-2.4 The following paints are stocked for use by AIC gas field personnel:

Color	Utility	Stock No.
Yellow	Gas Facilities	30 60 044
White	Proposed Excavation	30 51 384
		30 60 246

B-2.5 Contract locators supply their own marking paint which has been approved (or subject to approval) by Damage Prevention.

B-3. Marking Flags

The following marking flags are stocked for use by AIC gas field personnel:

Color	Utility	Stock No.
Yellow/Gas	Gas Facilities	16 02 183
Yellow/No Gas		16 02 348
White	Proposed Excavation	16 02 568

LOCATING

December 1, 2020

LOCT 2 Forms and Reference Materials

These documents are available on the drive at O:\Gas Operating & Maintenance Plan\LOCT - Locating\Forms and Reference Materials.

Forms

1. [JULIE Locate Request Form, Rev 1-1-2012](#)

Reference Materials

1. [AIC Marking Standards](#)
2. [Ditch Witch 900R/T Series Operators Manual](#)
3. [3M Dynatel 550-2573 Operators Manual](#)
4. [Dynatel 500A/P Cable Locator Operators Manual](#)
5. [Dynatel 2210 Cable Locator Operators Manual](#)
6. [Fisher TW-6 Pipe and Cable Locator Operating Manual](#)
7. [Fisher TW 82 Digital Line Tracer Operating Manual](#)
8. [Goldak 902 Pipe & Cable Locator Operating Manual](#)
9. [Goldak/UDSEC TR-5A Pipe/Cable Locator Operating Manual](#)
10. [Heath LS-800 Pipe and Cable Locating System Instruction Manual](#)
11. [Heath Sure Lock All Pro User's Manual](#)
12. [Jameson Gas Line Tracer Instruction Manual](#)
13. [MADE Acoustic Gas Tracker Operation Manual](#)
14. [MADE Gas Tracker New Quick Start Guide](#)
15. [Metrotech 480B Pipe and Cable Locator Operations Manual](#)
16. [Metrotech 810 Pipe and Cable Locator Operations Manual](#)
17. [Metrotech 850 Line Tracer Operations Manual](#)
18. [Metrotech 9800 Line Locator Operations Manual](#)
19. [Metrotech 9800XT Utility Line Locator Operations Manual](#)
20. [Nilsson 715 Pipe & Cable Locator Instruction Manual](#)
21. [Pipehorn 100 Pipe and Cable Locator User Manual](#)
22. [Pipehorn 500 Dual-Frequency Pipe and Cable Locator User Manual](#)
23. [Pipehorn 800-HL User Manual](#)
24. [Radiodetection RD4000 Locating System User Manual](#)
25. [Radiodetection RD7000 Operation Manual](#)
26. [Radiodetection RD7100 Locator User Guide](#)
27. [Radiodetection RD7100 Locator Operation Manual](#)

UNCONTROLLED IF PRINTED

- 28. [Radiodetection RD8000 User Guide](#)
- 29. [Radiodetection RD8100 Locator User Guide](#)
- 30. [Radiodetection RD8100 Locator Operation Manual](#)
- 31. [Rycom 8869 Cable, Pipe and Fault Locator User's Manual](#)
- 32. [Rycom 8875 Cable and Pipe Locator User's Manual](#)
- 33. [Subsite 75R/T Operators Manual](#)
- 34. [Verifier G2 Digital Locator Operation Manual](#)
- 35. [Vivax vLocPro User Handbook](#)
- 36. [Vivax vLocPro 2 vLocML2 User Handbook](#)

End of Section.

Operator Qualification (OQ) Required?

NO

Appendices

NONE

Attachments

NONE

Compliance Requirements

NONE

Reference Documents

[LOCT 1 Locating: Methods](#)

Document Rescission

LOCT 2 Locating – Forms and Reference Materials, October 1, 2020

Revision Notes

Location of Changes	Summary of Changes
LOCT2	Made format consistent with other Forms and Reference Material Sections.

MAIN-Main Installation

MAIN INSTALLATION

October 1, 2022

MAIN 0 Table of Contents

[MAIN 1 Main Installation: Requirements](#)

Section 1.0 Purpose

Section 2.0 Scope

Section 3.0 Target Audience

Section 4.0 Location

Section 5.0 Cover

Section 6.0 Pipe Handling

Section 7.0 Trench Requirements

Section 8.0 Excavation and Work Area Protection

Section 9.0 Laying and Lowering

Section 10.0 Underground Clearances

Section 11.0 Joining

Section 12.0 Offset Bends

Section 13.0 Protection and Backfill

Section 14.0 14.0 Trenchless Excavation Installations

Section 15.0 Pigging

Section 16.0 Clean Up

Section 17.0 Back-Flagging

Section 18.0 Design Considerations

Section 19.0 Records

Operator Qualification (OQ)

Appendices

Appendix A - Tuff-N-Nuff Rock Shield

Compliance Requirements

Reference Documents

Document Rescission

[MAIN 2.1 Main Installation: Joint Trench Installation](#)

Section 1.0 Purpose

UNCONTROLLED IF PRINTED

Section 2.0 Scope
Section 3.0 Target Audience
Section 4.0 General
Section 5.0 Gas/Electric Joint Trench Installation
Section 6.0 Multiple Utility Joint Trench Installation
Operator Qualification (OQ)
Compliance Requirements
Reference Documents
Document Rescission

MAIN 2.2 Main Installation: Lowering or Realignment of Pipe

Section 1.0 Purpose
Section 2.0 Scope
Section 3.0 Target Audience
Section 4.0 General
Section 5.0 Engineering Review
Section 6.0 Steel Pipe Maximum Potential Realignment Distance (Strip Back)
Section 7.0 PE Pipe Maximum Potential Realignment Span
Section 8.0 Realignment Concerns
Section 9.0 Inspections Required Prior to Movement
Section 10.0 Performing the Work
Section 11.0 Inspections Required After Movement
Operator Qualification (OQ)
Compliance Requirements
Reference Documents
Document Rescission

Main 2.3 Main Installation: Pull Out Prevention

Section 1.0 Purpose
Section 2.0 Scope
Section 3.0 Target Audience
Section 4.0 General
Section 5.0 Constraint
Operator Qualification (OQ)
Compliance Requirements
Reference Documents
Document Rescission

Main 2.4 Main Installation: Temporary Pipeline Support

Section 1.0 Purpose
Section 2.0 Scope
Section 3.0 Target Audience
Section 4.0 General
Section 5.0 Support Method Table
Section 6.0 Temporary Support Methods
Operator Qualification (OQ)
Compliance Requirements
Reference Documents
Document Rescission

Main 2.5 Main Installation: Pipe Coating and Gasket Removal

Section 1.0 Purpose
Section 2.0 Scope
Section 3.0 Target Audience
Section 4.0 General
Section 5.0 Sample Testing
Section 6.0 Notifications
Section 7.0 Inspections
Section 8.0 Personal Protective Equipment (PPE), Equipment, Materials, Tools
Section 9.0 Pipe Wrap and Gasket Removal Procedures
Section 10.0 Waste Transportation
Section 11.0 Collection and Storage for Disposal
Section 12.0 PPE, Material & Equipment
Operator Qualification (OQ)
Appendices
 Appendix A - PPE, Material, and Equipment
Compliance Requirements
Reference Documents
Document Rescission

Main 2.6 Main Installation: Insertion

Section 1.0 Purpose
Section 2.0 Scope
Section 3.0 Target Audience

Section 4.0 General
Section 5.0 Considerations
Section 6.0 Planning
Section 7.0 Tracer Wire Installation
Section 8.0 Insertion Procedures
Section 9.0 Conduit or Sleeve Insertion Procedures
Operator Qualification (OQ)
Compliance Requirements
Reference Documents
Document Rescission

Main 3.1 Main Installation: Lateral Taps

Section 1.0 Purpose
Section 2.0 Scope
Section 3.0 Target Audience
Section 4.0 PE Tees to PE Pipe
Section 5.0 Steel Tees to PE Pipe
Section 6.0 Steel Tees to Steel Pipe
Operator Qualification (OQ)
Appendices
 Appendix A - PE Tees to PE Pipe
 Appendix B - Steel Tees to PE Pipe
 Appendix C - Steel Tees to Steel Pipe
Compliance Requirements
Reference Documents
Document Rescission

Main 3.2 Main Installation: End of Main Extension

Section 1.0 Purpose
Section 2.0 Scope
Section 3.0 Target Audience
Section 4.0 Main Extension-PE Pipe
Section 5.0 Main Extension-Steel to PE Pipe
Section 6.0 Main Extension-Steel to Steel Pipe
Operator Qualification (OQ)
Appendices
 Appendix A - Main Extension - PE Pipe

UNCONTROLLED IF PRINTED

Appendix B - Main Extension - Steel to PE Pipe

Appendix C - Main Extension - Steel to Steel Pipe

Compliance Requirements

Reference Documents

Document Rescission

End Table of Contents.

Document Rescission

MAIN 0 Main Installation: Table of Contents, October 1, 2020.

Revision Notes

Location of Changes	Summary of Changes
MAIN 3.1	Revisions made to some of the section headings

MAIN INSTALLATION

April 1, 2023

MAIN 1 Requirements

1.0 Purpose

The purpose of this procedure is to prescribe the requirements for installing gas mains. The design, construction and testing of mains shall comply with all applicable local and state regulations. The procedure also meets minimum requirements of 49 CFR §§ 192.319, 192.325, and 192.327.

The term “main” in this document refers to distribution and high pressure distribution mains or transmission lines and pipelines.

2.0 Scope

This document addresses the following:

[3.0 Target Audience](#)[4.0 Location](#)[5.0 Cover](#)[6.0 Pipe Handling](#)[7.0 Trench Requirements](#)[8.0 Excavation and Work Area Protection](#)[9.0 Laying and Lowering](#)[10.0 Underground Clearances](#)[11.0 Joining](#)[12.0 Offset Bends](#)[13.0 Protection and Backfill](#)[14.0 Trenchless Excavation Installations](#)[15.0 Pigging](#)[16.0 Clean Up](#)[17.0 Back-Flagging](#)[18.0 Design Considerations](#)[19.0 Records](#)

Appendices:

[Appendix A - Tuff-N-Nuff Rock Shield](#)

3.0 Target Audience

- Gas Engineering
- Gas Distribution Design Specialist
- Field Engineering Representatives
- Gas Field Personnel
- Gas Supervisors
- Gas Construction Services personnel

UNCONTROLLED IF PRINTED

4.0 Location

- 4.1 Mains shall be installed in streets, alleys, utility easements, or within granted private easements.
- 4.2 Permits and easements requirements shall be determined and the necessary easements be obtained before starting construction.

Permits are generally required for crossing or parallel encroachments on railroads and state, county, city and township roads.

- 4.3 Main installations shall comply with the provisions of franchises, permits, and easements.
- 4.4 New, relocated, or replaced mains shall not be installed under buildings.

5.0 Cover (49 CFR §192.327 Cover)

- 5.1 Each main must be installed with a minimum cover, measured from the top of the pipe, as listed in Table 1.

Table 1 Minimum Cover Requirements

Minimum Cover Requirements		
Main Type or Location	Normal Soil inches	Consolidated Rock inches
Distribution Mains and High Pressure Distribution Mains	30	24
Transmission Lines	36	24
Crossings of Navigable Rivers or Streams	48	24
Permitted Highway and Railroad Crossings	As specified on permit	As specified on permit

- 5.2 Where an existing underground structure prevents the installation with minimum cover, the main may be installed provided that additional protection against anticipated external loads such as loaded truck traffic, material storage, or farming operations.
 - 5.2.1 If such conditions are encountered, the Gas Supervisor or Contractor Services Supervisor shall contact either area Gas Engineering for distribution main installations or Gas Tech Engineering (GTE) for transmission for high pressure distribution installations or Gas Storage Engineer (GSE) for gas storage field installations.
 - 5.2.2 Engineering personnel will review to determine if additional protection is required and specify appropriate protection method to protect the main from anticipated external loads.
 - 5.2.3 Location of shallow main should be recorded on the As-Built plans and indicated on Ameren Illinois (AIC) gas electronic mapping system.
- 5.3 Where gas carrying fittings are attached to mains, fittings **should** have a minimum cover of **24 inches**.

- 5.4 If the minimum cover cannot be maintained, then install Safety Barrier Tape (Stock Code 16 06 958) approximately 12 inches below the surface to provide advance warning to excavators. **For additional protection Tuff-N-Nuff (49 22 241) may be used. See [Appendix A](#).**
- 5.5 In cultivated areas, areas where future grading is required, or in areas subject to erosion, additional cover must be provided to compensate for these conditions.
 - 5.5.1 Gas Engineering shall specify additional depth requirements.
- 5.6 Gas mains shall not be installed more than 48 inches deep to prevent the need for shoring or other protective systems during installation or in future excavations unless required for:
 - 5.6.1 Road crossings,
 - 5.6.2 Railroad crossings,
 - 5.6.3 Stream crossings,
 - 5.6.4 Avoid conflict with another buried facilities,
or
 - 5.6.5 Specified by Gas Engineering.

6.0 Pipe Handling

- 6.1 Handle pipe in a manner that will prevent damage to the pipe or coating.
- 6.2 Load and unload pipe with non-abrasive canvas slings, padded calipers, or by hand.
- 6.3 **Do not** roll or drop pipe from trailers.
- 6.4 When unloading pipe at the job site carry it. **Do not** drag it into position.

7.0 Trench Requirements (49 CFR §192.319)

- 7.1 Trenches shall be a minimum of 2 inches wider than the main being installed.
- 7.2 The trench bottom should provide a firm bearing for the pipe to minimize stresses.
- 7.3 Keep trench clean of rocks and other debris that might damage the pipe or coating.

8.0 Excavation and Work Area Protection

- 8.1 Shoring, sloping, and benching of excavations shall be in accordance with [EXCV 1](#).
- 8.2 Always maintain safe public access around and through the construction zone.
- 8.3 Barricades, signs, warning lights, flagmen and other safety devices shall be used to protect the construction area.

9.0 Laying and Lowering

- 9.1 Place the main in the trench without damaging the pipe or coating.
- 9.2 Lower the main into the ditch with sufficient slack to allow for expansion and contraction.
- 9.3 Ensure that the main fits the ditch without the use of external force to hold it in place.
- 9.4 Seal pipe ends at the end of each day to prevent the following from entering the pipe:
 - 9.4.1 Debris
 - 9.4.2 Water

9.4.3 Animals

9.5 Visually inspect the pipe and pipe coating as it is laid in the ditch looking for the following that could affect serviceability of the pipe:

9.5.1 Gouges

9.5.2 Small dents

9.5.3 Scraps

9.5.4 Other damages or imperfections.

9.6 Consider use of pipe rollers when pulling coated steel pipe to protect the pipe and coating from damage.

10.0 Underground Clearances (49 CFR §192.325)

10.1 Underground clearances apply to plastic and steel pipe that is installed either by direct bury excavation, boring or other trenchless methods.

10.2 At the time of installation, there shall be sufficient clearance to allow for installation and maintenance activities:

10.2.1 A minimum of 12 inches vertically and horizontally, between transmission lines, high pressure distribution mains or distribution mains and existing buried:

1. Utility lines (electric, telephone, cable, etc.)
2. Structures (drainage, storm sewers, etc.)
3. Pipes (gas, water, sewer, drain, etc.)
4. Abandoned facilities since they have the potential to provide a path for migration of leaking gas

10.2.2 If the minimum clearance is not possible, then adequate measures shall be taken to protect the pipe from damage by installing means such as,

1. A sleeve shield
2. Tuff-N-Nuff (Refer to [Appendix A](#))
3. Rubber matting
4. Fiberglass or PVC shield
5. Sand-cement bags
6. Concrete pads
7. A casing pipe shall be installed around or along the main
8. Gas Engineering, GTE, or GSE may specify an alternative protection method.

Electric lines can produce heat.

10.2.3 Refer to [POLY 2.3, Section 7.0](#), Clearance from Thermal Sources, if PE pipe is being installed near a steam pipe.

10.3 Clearance should be adequate to install a pressure control fitting or leak repair clamps on steel mains, squeeze off PE mains or install lateral main connections or services.

UNCONTROLLED IF PRINTED

10.4 See MAIN 2.1 for additional clearances associated with joint trench installations.

11.0 Joining

11.1 Welding is the principal method for joining steel pipe. See [WELD 2.3](#) and [WELD 4](#) for acceptable welding procedures.

11.2 Butt fusion and electrofusion shall be used to join PE mains. See [POLY 2.4](#) and [POLY 2.5](#).

11.3 Mechanical fittings shall not be used to permanently join gas main.

12.0 Offset Bends

12.1 See [STLP 1](#) for offset bends in steel pipe and [POLY 2.3, Section 9.0](#) for the minimum bending radius for PE pipe.

12.2 Fittings shall be used when bending the pipe is not feasible.

13.0 Protection and Backfill

13.1 All debris shall be removed from trenches before backfilling.

13.2 Each gas main shall be protected from washouts, floods, unstable soil, landslides or other hazards that may cause the main to move and/or to sustain abnormal loads.

Excavated material used for backfill must be free of rock (larger than 2 inches), construction debris, concrete or asphalt chunks, brush, skids, or other debris materials that could damage the pipe or its coating.

13.2.1 The main shall be protected from rock or other abrasive material that could damage the pipe or its coating. Use one of the following over the pipe before backfilling with spoils containing rock, gravel or cinders is placed in the excavation.

1. A minimum layer, approximately twelve (12) inches thick, of clean construction material,

2. Granular material equal to or less than 1/4",

OR

3. Sand.

13.3 If suitable material is not available to initially cover the pipe, then install a rock shield such as Tuff-N-Nuff (see [Appendix A](#)) or a rigid sleeve.

13.4 Backfill the main in a manner that provides firm support under the pipe and prevents damage to the pipe and coating from equipment or from backfill material.

13.5 Install wash-out breakers, made from sacks filled with earth or sand and placed in the ditch over the pipe, where necessary to prevent the fresh backfill from being washed out of the ditch.

13.6 Use sufficient backfill so that depressions do not occur after settlement.

13.7 Avoid excessive mounds.

13.8 Compact backfill by hand tamping, mechanical tamping, rolling, or wetting down.

- 13.9 Repair and resurface openings in streets, alleys and sidewalks in accordance with the permit or the municipality's regulations.

14.0 Trenchless Excavation Installations

- 14.1 [BORE 2.1 Section 5.0](#) addresses the general requirements for pipe being installed by boring methods.
- 14.2 [BORE 2.1 Subsection 5.2](#) addresses the installation of PE pipe.
- 14.3 [BORE 2.1 Subsection 5.3](#) addresses the installation of steel pipe.

15.0 Pigging

- 15.1 If the internal condition of new or replacement pipe cannot be visually inspected for debris or cleanliness, then consider pigging the pipe segment(s) before tying into existing mains.

Coiled plastic pipe that has been capped or plugged prior to installation does not need to be pigged unless a condition during installation resulted in contaminants entering the pipe.

16.0 Clean Up

- 16.1 Keep the right-of-way clear of construction debris during and after construction.

17.0 Back-Flagging

- 17.1 Newly installed AIC gas facilities shall be "back-flagged" as stated in [DAMG 1 Section 11.0](#).

18.0 Design Considerations

- 18.1 When designing a new pipeline or replacement project, care should be taken to consider safety of the public and co-workers as a top priority. Considerations include:
- 18.1.1 Work area protection.
 - 18.1.2 Traffic conditions.
 - 18.1.3 Depth at tie-in locations.
 - 18.1.4 Other utility locations
 - 18.1.5 Required PPE.
 - 18.1.6 Customer threats.
- 18.2 Additional considerations should be taken for the protection of the environment. Considerations include:
- 18.2.1 Location of valves, stoppers, and squeeze off locations are optimized to limit release of gas to the atmosphere.
 - 18.2.2 Existing system leaks are considered for repair opportunistically.
 - 18.2.3 Flaring on high pressure applications.
 - 18.2.4 Lowering of system pressure prior to purging.
 - 18.2.5 Ensuring the ability to locate the main in the future.

18.3 Prone-to-leak facilities should be considered for replacement opportunistically and on a program level based on risk results. These include:

18.3.1 Mechanically coupled steel.

18.3.2 Adyl-A.

18.3.3 Difficult to locate facilities.

19.0 Records

19.1 New, relocated or replaced gas mains shall be recorded on AIC's electronic mapping system within 90 days from the time the job has been completed and/or placed in Status 70 (Construction Completed) in DOJM.

19.1.1 Region operations or Gas Tech Engineering should review and approve the completed job packet within 30 days from the time the job is complete and/or move to Status 70 in DOJM.

19.1.2 The electronic mapping should be updated within forty-five (45) days of receipt of completed job packet and/or moved to Status 80 (Ready for Closing) in DOJM.

19.2 Required geospatial data for AIC's transmission pipelines will be submitted by Transmission Integrity Management (TIMP) personnel to the National Pipeline Mapping System (NPMS) on or before March 15th each year. The submitted data should reflect conditions in the field as of December 31st of the previous year.

End of Instructions.

Operator Qualification (OQ) Required?

YES

0151: Visual Inspection of Buried Pipe and Components when Exposed

0201: Visual Inspection of Buried Pipe and Components for Mechanical Damage

0301: Manually Opening and Closing Valves

0561: Pressure Test - Nonliquid Medium- MAOP Less than 100 psi

0571: Pressure Test - Nonliquid Medium - MAOP Greater than or Equal to 100 psi

0591: Leak Test at Operating Pressure

0641: Visually Inspect Pipe and Components Prior to Installation

0681: Joining of Plastic Pipe - Stab Fittings

0751: Joining of Plastic Pipe - Butt Heat Fusion: Manual

0761: Joining of Plastic Pipe - Butt Heat Fusion: Hydraulic Machine

0781: Joining of Plastic Pipe - Electrofusion

0801: Welding

0811: Visual Inspection of Welding and Welds

0861: Installation of Steel Pipe in a Ditch

UNCONTROLLED IF PRINTED

- 0891: Field Bending of Steel Pipe
- 0901: Installation of Plastic Pipe in a Ditch
- 0981: Backfilling
- 1291: Locate Underground Pipelines
- 1341: Provide or Assure Adequate Pipeline Support During Operator Initiated Excavation Activities
- 1651: Purge - Flammable or Inert Gas

Appendices

[Appendix A - Tuff-N-Nuff Rock Shield](#)

Attachments

NONE.

Compliance Requirements

- 49 CFR §192.319 Installation of pipe in a ditch.
- 49 CFR §192.325 Underground clearance.
- 49 CFR §192.327 Cover.

Reference Documents

[DAMG 1 Damage Prevention: Requirements](#)

Document Rescission

MAIN 1 Main Installation: Requirements, May 15, 2022

Revision Notes

Location of Changes	Summary of Changes
Subsection 5.3	Revised – Where gas carrying fittings are attached to mains, fittings should have a required minimum cover of 24 inches.
Subsection 5.4	Added : For additional protection Tuff-N-Nuff (49 22 241) may be used/ See Appendix A Removed 5.4.1 since Safety Wrap is no longer manufactured.
Subsection 19.2	Required geospatial data for AIC's transmission pipelines will be submitted by Transmission Integrity Management (TIMP) personnel to the National Pipeline Mapping System (NPMS) on or before March 15th each year. The submitted data should reflect conditions in the field as of December 31 of the previous year.

Appendix A - Tuff-N-Nuff Rock Shield

A-1. General

- A-1.1 Tuff-N-Nuff rock shield is to be used when placing rip-rap or other rock over pipes to prevent future erosion.

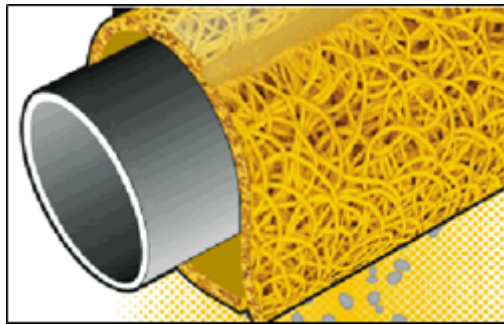

Tuff-N-Nuff Rock Shield (49 22 241)

3/8" thick x 36" wide x 30' long

- A-1.2 The porosity of Tuff-N-Nuff allows cathodic protection to reach the pipe without shielding.

A-2. Installation

- A-2.1 Always check and repair pipe coating before installing Tuff-N-Nuff.
- A-2.2 Cigarette wrap around the pipe cutting to the desired length.
- A-2.3 Rock shield should be positioned flat side out, rough side to the pipe.
- A-2.4 It is recommended to overlap the sides at the 6 o'clock position of the pipe to insure "double layer" protection at the critical weight bearing point.
- A-2.5 If side overlap is used, (3 or 9 o'clock positions) shiplap the sides over the top to avoid "cupping" that could divert backfill under the rockshield.
- A-2.6 Use tape to hold the wrap in place.

Tuff-N-Nuff can be ordered for specific pipe diameters to minimize waste on large projects.

MAIN INSTALLATION

October 1, 2021

MAIN 2.1 Joint Trench Installation

1.0 Purpose

The purpose of this standard is to prescribe the requirements for installing gas mains and service lines in a joint trench. The procedures in this document meet the minimum requirements of 49 CFR §§ 192.325 and 192.327.

2.0 Scope

This document addresses the following:

[3.0 Target Audience](#)

[4.0 General](#)

[5.0 Gas/Electric Joint Trench Installation](#)

[6.0 Multiple Utility Joint Trench Installation](#)

3.0 Target Audience

- Gas Engineering
- Gas Distribution Design Specialist
- Field Engineering Representatives
- Gas Field Personnel
- Gas Supervisors
- Gas Construction Services Personnel

4.0 General

4.1 When conditions warrant joint trench installation, the specifications of this standard shall be followed.

5.0 Gas/Electric Joint Trench Installation (49 CFR §§ 192.325, 192.327)

5.1 Installation Requirements

5.1.1 Bottom of trench should be free from:

1. Rocks
2. Debris
3. Abrupt changes in elevation

5.1.2 Mechanical tamping of the trench bottom should be done in fill areas and where excessive settling might occur.

5.1.3 Use clean backfill that is free from debris that may damage the gas line or electric cable.

1. Place 12 inches of backfill over the electric and gas line.
2. Maintain a minimum of 12 inches of clearance between facilities. See [Figures 1 and 2](#).

5.1.4 The top 24 inches of the trench shall require mechanical tamping if under a surface traversed by vehicle traffic.

UNCONTROLLED IF PRINTED

- 5.1.5 Place gas main above electric line for main/primary installations due to tapping required for gas service lines. See Figure 1.
- 5.1.6 Joint trench for service lines may be installed with the gas service line on top and the electric service on the bottom. See Figure 2.
- 5.1.7 If required minimum cover cannot be maintained, then install Safety Barrier Tape (Stock Code 16 06 958) approximately 12 inches below the surface to provide advance warning to excavators. See [MAIN 1](#).

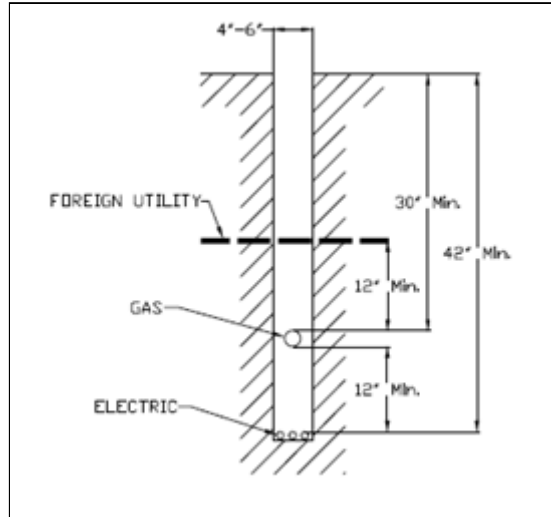

Figure 1

Joint Primary/Secondary and Gas Main Trench Detail

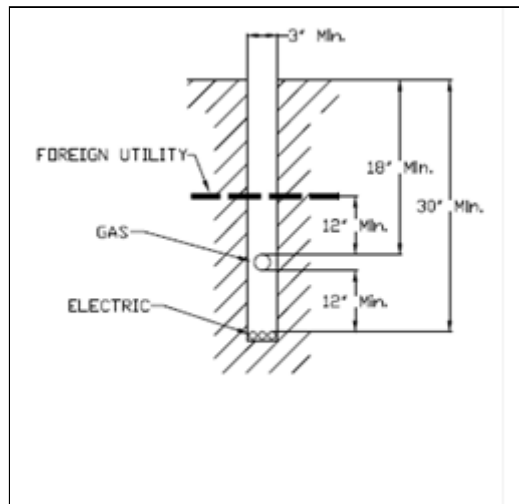

Figure 2

Typical Joint Service Trench Detail

- 5.1.8 For lateral crossings of other facilities, it is recommended to maintain a minimum clearance of 12 inches.
- 5.1.9 "Joint Trench" shall be noted on the appropriate as-built construction plans or service record.

5.2 Typical Joint Service Trench Route

5.2.1 The typical layout for a gas and electric service line joint trench installation is shown in Figure 3.

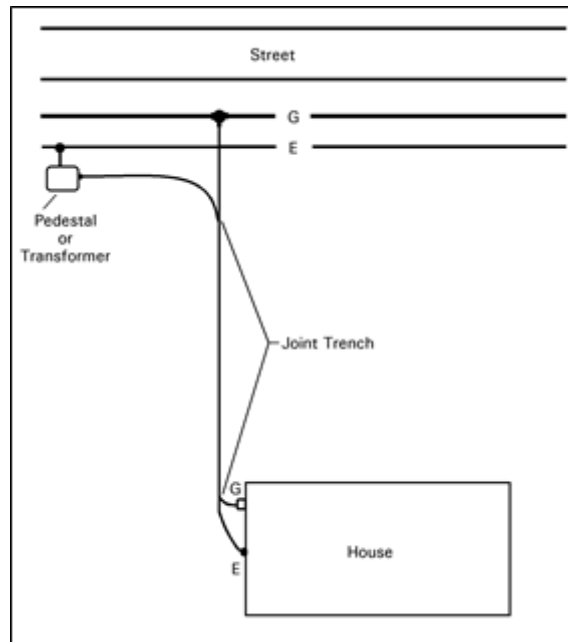

Figure 3 Trench Route

6.0 Multiple Utility Joint Trench Installation

6.1 In multiple utility joint trench installations, all natural gas facilities should be installed above all other utilities at minimum depth requirements and with 12 inches of separation.

End of Instructions.

Operator Qualification (OQ) Required?

YES

0151: Visual Inspection of Buried Pipe and Components when Exposed

0201: Visual Inspection of Buried Pipe and Components for Mechanical Damage

0641: Visually Inspect Pipe and Components Prior to Installation

0901: Installation of Plastic Pipe in a Ditch

0981: Backfilling

1291: Locate Underground Pipelines

1341: Provide or Assure Adequate Pipeline Support During Operator Initiated Excavation Activities

Appendices

NONE.

Attachments

NONE.

Compliance Requirements

UNCONTROLLED IF PRINTED

49 CFR §192.325 Underground clearance.

49 CFR §192.327 Cover.

Reference Documents

[MAIN 1 Main Installation: Requirements](#)

Common Ground Alliance Best Practices (online [here](#))

Document Rescission

MAIN 2.1 Main Installation: Joint Trench Installation, October 1, 2020.

Revision Notes

Location of Changes	Summary of Changes
Paragraph 5.1.8	Maintain a minimum of 12 inch clearance for lateral crossing of other facilities.

MAIN 2.2 Lowering or Realignment of Pipe

1.0 Purpose

This procedure is a guide in determining the feasibility of safely lowering or realigning in-service pipe and performing such work.

2.0 Scope

This document addresses the following:

[3.0 Target Audience](#)

[4.0 General](#)

[5.0 Engineering Review](#)

[6.0 Steel Pipe Maximum Potential Realignment Distance \(Strip Back\)](#)

[7.0 PE Pipe Maximum Potential Realignment Span](#)

[8.0 Realignment Concerns](#)

[9.0 Inspections Required Prior to Movement](#)

[10.0 Performing the Work](#)

[11.0 Inspections Required After Movement](#)

3.0 Target Audience

- Gas Engineering
- Gas Distribution Design Specialist
- Field Engineering Representatives
- Gas Tech Services (GTS) Supervisors
- Gas Tech Services (GTS) Personnel
- Gas Storage Engineer (GSE)
- Gas Storage Field Personnel
- Gas Storage Field Supervisor
- Gas Field Personnel
- Gas Supervisors
- Gas Construction Services Personnel

4.0 General

4.1 The realignment of in-service pipe (movement in any direction) is done to clear shorts and realign pipe in conflict with other utilities or planned excavation activities.

4.2 The following groups shall be responsible for determining the feasibility of safely lowering or realigning in-service pipe:

4.2.1 Gas Region Engineering

1. Steel pipe with a Design MAOP of 60 PSIG or less

OR

2. PE pipe having Design MAOP of 125 PSIG or less.

4.2.2 Gas Tech Engineering (GTE):

1. Steel pipe with Design MAOP greater than 60 PSIG.

4.2.3 Gas Storage Engineer (GTE):

UNCONTROLLED IF PRINTED

1. Piping within the storage field.

5.0 Engineering Review

- 5.1 If an application for lowering an in-service pipe appears feasible, an analysis should be completed by Region Gas Engineering, GTE, or GSE depending on the Design MAOP and pipe material. The analysis shall include,
 - 5.1.1 Review of pipe records
 - 5.1.2 Joint type
 - 5.1.3 Leak history
 - 5.1.4 Attached appurtenances
 - 5.1.5 Terrain
 - 5.1.6 Excavation safety
 - 5.1.7 Other underground facility conflicts.
- 5.2 A field procedure for lowering in-service pipe should be completed, and may include:
 - 5.2.1 A general procedure. (see [Section 10](#))
 - 5.2.2 The minimum strip-back length.
 - 5.2.3 A depth profile.
 - 5.2.4 Emergency shutdown procedures.
 - 5.2.5 Pipeline support method.
 - 5.2.6 Pipeline movement method.

6.0 Steel Pipe Maximum Potential Realignment Distance (Strip Back)

- 6.1 The strip back distances shown in the following table represent "L" as shown in [Figure 1](#), not the total ditch length.
 - 6.1.1 Total ditch length = (Minimum of two times the strip back distance) + (Length of the pipe to be lowered).

These are minimum distances from the location where change in elevation starts at the original elevation to where change in elevation ends at the new elevation.

- 6.2 For pipe sizes, wall thickness, pipe grade and depth of lower **NOT SHOWN** in Table 1, consult with Gas Tech Engineering or Gas Region Engineer for strip back distances per API RP 1117, Movement of In-Service Pipelines.

Table 1: Minimum Strip Back Distances

MAOP (psi)	Nominal Pipe Size (inches)	OD (inches)	Wall Thickness (inches)	Pipe Grade	Yield Strength (psi)	Depth of Lower (h)		
						1 ft.	3 ft.	5 ft.
						Strip Back Length (L) in Feet		

60 or less	2	2.375	0.154	B	35,000	89	214	335
				A25	25,000	110	263	412
	4	4.500	0.188	B	35,000	109	240	364
				A25	25,000	134	295	447
	6	6.625	0.219	B	35,000	126	263	390
	8	8.625	0.250	B	35,000	140	284	413
	10	10.750	0.250	B	35,000	153	233	437
12	12.750	0.250	B	35,000	165	322	458	

Notes

1. Calculation Criteria: Pipe Design Factor = 0.72, Installation Temperature = 60° F, Operating Temperature 40° F.
2. Calculations used Pipeline Tool Box App. Ref: API RP 1117 Manual Movement of In-Service Pipelines.
3. Footage represents the total minimum trench length (L) to realign pipeline.
4. Legacy companies only purchased Grade A25 pipe 4 inch or less diameter.

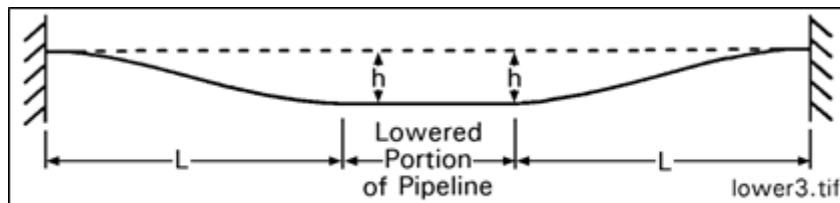

Figure 1 Steel Pipe Lowering Schematic

7.0 PE Pipe Maximum Potential Realignment Span

7.1 The distances shown in Table 2 represent the total ditch length (L) that allows for an approximate 6-inch drop (D). For ditch lengths that allow for drops other than 6 inches contact engineering. See [Figure 2](#) for PE pipe lowering schematic.

Table 2: Ditch Length vs PE pipe drop

Size (inches)	Ditch Length "L" (feet)	Approximate Drop "D" (inches)
2	11.5	6
3	14.0	6
4	16.0	6
6	19.0	6
8	21.5	6

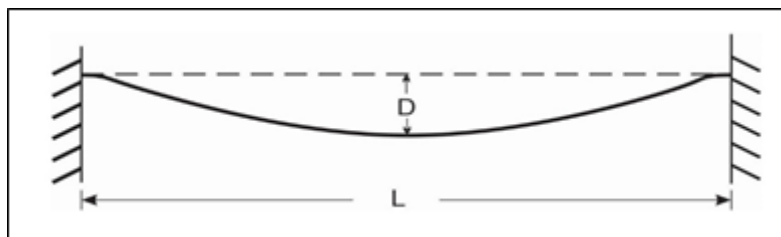

Figure 2 PE Pipe Lowering Schematic

UNCONTROLLED IF PRINTED

8.0 Realignment Concerns

8.1 Items to consider when moving, realigning, or lowering pipe:

8.1.1 Maintain Pipe Integrity

1. The primary concern when realigning a pipe in service, besides attaining the required depth, is preserving its integrity.
2. Pipeline integrity is threatened by construction equipment or failure of the pipe from being overstressed through improper lowering practices.

Hazards caused by a puncture or rupture, during realigning, can be reduced by minimizing the operating pressure. Buckling and tensile failure can be avoided by limiting the stress level and deformation of the pipe during realigning.

8.1.2 Recognize Terrain Limitations

1. Pipes in relatively level terrain generally have lower values of internal stress. Pipes installed on steep hillsides could be under additional stress due to potentially unstable slope.

Avoid realigning pipes in unstable soils or soil which is subjected to frost heave.

8.1.3 Consider Soil Types

1. The soil type will dictate whether the pipe is realigning in a vertical plane or offset to the side.
2. Rock or cohesive soils may allow an offset trench for realigning the pipe to the side.
3. Realigning the pipe into an offset trench is not as easy as a vertical drop, and involves increased stresses.

8.1.4 Examine Types of Welds

Avoid realigning pipes larger than 1 1/4" that contain acetylene welds.

1. Prior to realigning the in-service pipe, consider performing visual and nondestructive inspection of girth welds.
2. Prior to movement, repair welds of questionable or unknown quality as identified by the inspection. See [REPR 1, Section 7.0](#) for transmission or HP distribution or [REPR 1, Section 8.0](#) for distribution pipe.

8.1.5 Know the Pipe Being Moved

1. Review available records for features such as the following, all of which can affect realignment:
 - 1 a. Pipe material properties (i.e., grade, wall thickness and seam)
 - 1 b. Age
 - 1 c. Leak repair history
 - 1 d. Location of fittings and field bends
- 8.1.6 Lowering Induced Stresses
1. There are temporary and permanent stresses induced on a pipe by realigning.
 2. The curvature change and elongation required for the pipe to fit the new trench profile can cause permanent stresses.
 3. Lifting the pipe during the realigning process and temperature changes experienced by the freshly exposed pipe can cause temporary stresses.

Temperature induced stresses can be reduced by realigning the pipe during warm weather.

9.0 Inspections Required Prior to Movement

- 9.1 External corrosion. See [CORR 1 Section 9](#) "External Corrosion Visual Inspection and Repair" for requirements.
- 9.2 Mechanical damage. See [REPR 1](#) if defects are found.
- 9.3 Pipe coating. See [CORR 2.3 Section 11.0](#) Coating Inspection if defects are found.

10.0 Performing the Work

- 10.1 Use the following procedure when performing the work.
 - 10.1.1 Monitor the operating pressure during realignment to ensure that the maximum operating pressure (MOP) is not exceeded.
 - 10.1.2 Plan for fast shutdown and isolation of the pipeline being worked on if the MOP is exceeded.
 - 10.1.3 Minimize personnel and public exposure at the work site.
 - 10.1.4 Anticipate potential adverse effects of:
 1. Weather conditions
 2. Ground and surface water
 3. Bank stability
 - 10.1.5 Check the adequacy of pipe supports to prevent unintended movement.
 - 10.1.6 Ensure backfill and compaction is performed to prevent additional movement due to settlement after realignment.

11.0 Inspections Required After Movement

- 11.1 Pipe coating. See [CORR 2.3 Section 11.0](#) Coating Inspection if defects are found.

UNCONTROLLED IF PRINTED

End of Instructions.

Operator Qualification (OQ) Required?

YES

- 0151: Visual Inspection of Buried Pipe and Components when Exposed
- 0201: Visual Inspection of Buried Pipe and Components for Mechanical Damage
- 0211: Measure and Characterize Mechanical Damage on Installed Pipe and components
- 0301: Manually Opening and Closing Valves
- 0641: Visually Inspect Pipe and Components Prior to Installation
- 0861: Installation of Steel Pipe in a Ditch
- 0681: Joining of Plastic Pipe - Stab Fittings
- 0751: Joining of Plastic Pipe - Butt Heat Fusion: Manual
- 0761: Joining of Plastic Pipe - Butt Heat Fusion: Hydraulic Machine
- 0781: Joining of Plastic Pipe - Electrofusion
- 0681: Joining of Plastic Pipe - Stab Fittings
- 0751: Joining of Plastic Pipe - Butt Heat Fusion: Manual
- 0761: Joining of Plastic Pipe - Butt Heat Fusion: Hydraulic Machine
- 0781: Joining of Plastic Pipe - Electrofusion
- 0861: Installation of Steel Pipe in a Ditch
- 0901: Installation of Plastic Pipe in a Ditch
- 0981: Backfilling
- 0991: Coating Application and Repair - Brushed or Rolled
- 1001: Coating Application and Repair - Sprayed
- 1011: External Coating Application and Repair - Wrapped
- 1291: Locate Underground Pipelines
- 1341: Provide or Assure Adequate Pipeline Support During Operator Initiated Excavation Activities

Appendices

NONE.

Attachments

NONE.

Compliance Requirements

49 CFR §192.461 External corrosion control: Protective coating.

Reference Documents

[CORR 1 Corrosion Control: Requirements](#)

UNCONTROLLED IF PRINTED

[CORR 2.3 Corrosion Control: Coatings](#)

[REPR 1 Repairs: Requirements](#)

Document Rescission

MAIN 2.2 Main Installation: Lowering or Realignment of Pipe, October 1, 2021

Revision Notes

Location of Changes	Summary of Changes
Paragraph 4.2.1 Item 2. – Gas Re- gion Engineering	Updated – Responsible for PE pipe having Design MAOP of 125 psig.

1.0 Purpose

The purpose of this document is to define unconstrained, partially constrained, and unconstrained piping configurations. This document also provides instruction on the protection for coupling and compression fittings from pull out.

2.0 Scope

This document addresses the following:

[3.0 Target Audience](#)

[4.0 General](#)

[5.0 Constraint](#)

3.0 Target Audience

- Gas Engineering
- Gas Distribution Design Specialist
- Field Engineering Representatives
- Gas Tech Services (GTS) Personnel
- Gas Tech Services (GS) Supervisors
- Gas Storage Engineers (GSE)
- Gas Storage Field Operators
- Gas Field Personnel
- Gas Supervisors
- Gas Construction Services Personnel

4.0 General

4.1 All pipe joints, including temporary exposure, shall be protected from forces caused by:

- 4.1.1 Thrust
- 4.1.2 Thermal expansion
- 4.1.3 Contraction
- 4.1.4 Vibration
- 4.1.5 Weight of pipe and its contents.

Although movements seldom occur in buried piping systems due to restraint by the surrounding soil, there are forces that act on pressurized piping systems that tend to pull joints.

4.2 All piping joints shall have enough support or anchors to resist the thrust forces caused by restrictions, offsets, or bends in the pipe.

5.0 Constraint

5.1 The following illustrations explain the concept of unconstrained, constrained, and partially constrained piping configurations.

- 5.1.1 Unconstrained

1. When a piping system is unconstrained, the thrust forces are primarily supported by the clamping force the mechanical coupling has on the pipe. The coupling acts as both a pressure seal and a clamp. See Figure 1.

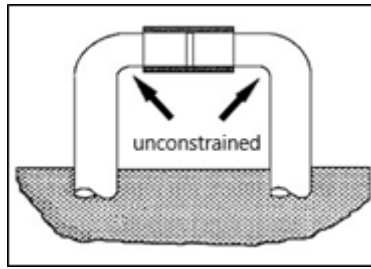

Figure 1 Unconstrained Piping System

5.1.2 Partially Constrained

1. When a piping system is partially constrained, the thrust forces are supported collectively by the clamping force of the mechanical coupling and the structural resistance of the piping assembly. See Figure 2.

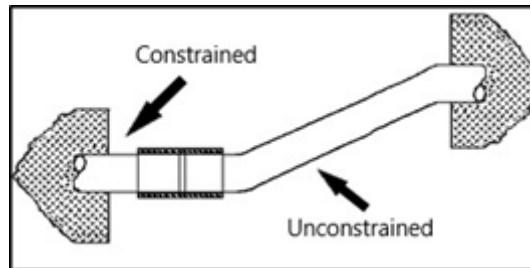

Figure 2 Partially Constrained Piping System

5.1.3 Fully Constrained

1. When a piping system is fully constrained, the thrust forces are contained by the friction between the piping and the soil. The mechanical coupling is only subject to the outward force of the gas pressure and acts only as a seal. See Figure 3.

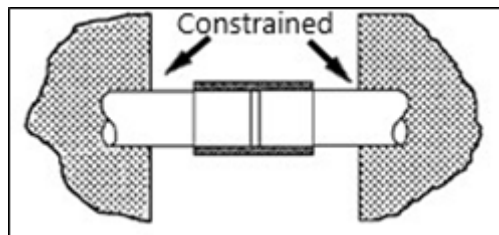

Figure 3 Fully Constrained Piping System

5.2 Couplings

- 5.2.1 Provisions shall be made to offset external forces if compression or sleeve couplings are used in a piping system.
 1. If such provisions are not inherent to the couplings design, then provide suitable anchoring or strapping.

Ameren Illinois (AIC) does not install compression fitting on new steel pipe installations. Compression fittings are not approved for use.

- 5.2.2 Ensure that design of bracing or strapping does not interfere with the normal performance of the coupling or with maintenance.
- 5.2.3 For above ground applications, joint harnesses are the recommended restraint.
- 5.2.4 For below ground applications, see welded strap requirements in [Figure 4](#).

5.3 Welded Strapping for Compression or Sleeve Couplings

- 5.3.1 Space the straps evenly around the pipe.
- 5.3.2 Contact Gas Engineering, GTS, or GSE for pipe sizes and pressures not shown in [Table 1](#).

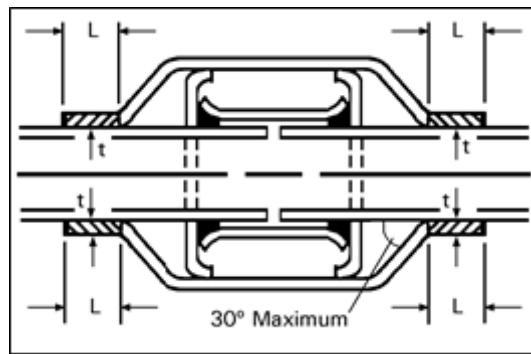

Figure 4 Welded Strapping for Compression or Sleeve Couplings

Strapping does not apply to PE systems.

Table 1: Strap and Weld Specifications

Pipe Size	Up To 100 psig Maximum			Up To 500 psig Maximum		
	Strap		Weld	Strap		Weld
	No.	t x w	S x L	No.	t x w	S x L
1 ¼"	2	1/8" x 1"	1/8" x 1"	2	1/8" x 1"	1/8" x 1"
2"	2	1/8" x 1"	1/8" x 1"	2	1/8" x 1"	1/8" x 1"
3"	2	1/8" x 1"	1/8" x 1"	2	1/4" x 1"	3/16" x 1"
4"	2	1/8" x 1"	1/8" x 1"	2	3/8" x 1"	5/16" x 1"
6"	2	1/4" x 1"	3/16" x 1"	2	3/8" x 1 3/4"	5/16" x 2 1/4"
8"	2	1/4" x 1"	3/16" x 1 1/4"	4	3/8" x 1"	5/16" x 1 3/4"
10"	2	1/4" x 1"	3/16" x 2"	4	3/8" x 1"	5/16" x 2 3/4"
12"	2	3/8" x 1"	5/16" x 1 3/4"	4	3/8" x 1"	5/16" x 4"

No. = number of A36 bar stock straps to be used.
 T = thickness of A36 bar stock strap
 W = width of A36 bar stock strap
 s = size of fillet weld (height)
 L = length of fillet weld on each side of strap at each end

End of Instructions.

Operator Qualification (OQ) Required?

UNCONTROLLED IF PRINTED

YES

- 0151: Visual Inspection of Buried Pipe and Components when Exposed
- 0201: Visual Inspection of Buried Pipe and Components for Mechanical Damage
- 0211: Measure and Characterize Mechanical Damage on Installed Pipe and Components
- 0301: Manually Opening and Closing Valves
- 0641: Visually Inspect Pipe and Components Prior to Installation
- 0861: Installation of Steel Pipe in a Ditch
- 0681: Joining of Plastic Pipe - Stab Fittings
- 0751: Joining of Plastic Pipe - Butt Heat Fusion: Manual
- 0761: Joining of Plastic Pipe - Butt Heat Fusion: Hydraulic Machine
- 0781: Joining of Plastic Pipe - Electrofusion
- 0681: Joining of Plastic Pipe - Stab Fittings
- 0751: Joining of Plastic Pipe - Butt Heat Fusion: Manual
- 0761: Joining of Plastic Pipe - Butt Heat Fusion: Hydraulic Machine
- 0781: Joining of Plastic Pipe - Electrofusion
- 0861: Installation of Steel Pipe in a Ditch
- 0901: Installation of Plastic Pipe in a Ditch
- 0981: Backfilling
- 0991: Coating Application and Repair - Brushed or Rolled
- 1001: Coating Application and Repair - Sprayed
- 1011: External Coating Application and Repair - Wrapped
- 1291: Locate Underground Pipelines
- 1341: Provide or Assure Adequate Pipeline Support During Operator Initiated Excavation Activities

Appendices

NONE.

Attachments

NONE.

Compliance Requirements

NONE.

Reference Documents

NONE.

Document Rescission

MAIN 2.03 Main Installation: Pull Out Prevention, January 1, 2011.

Revision Notes

Location of Changes	Summary of Changes
Not applicable.	This is a new document.

MAIN INSTALLATION

May 15, 2022

MAIN 2.4 Temporary Pipeline Support

1.0 Purpose

This document provides various methods to temporarily support pipelines during construction in compliance with 49 CFR §192.161.

2.0 Scope

This document addresses the following:

[3.0 Target Audience](#)

[4.0 General](#)

[5.0 Support Method Table](#)

[6.0 Temporary Support Methods](#)

3.0 Target Audience

- Gas Technical Engineering (GTE)
- Gas Distribution Design Specialist
- Field Engineering Representatives
- Gas Field Personnel
- Gas Tech Services (GTS) Supervisors
- Gas Tech Services (GTS) Personnel
- Gas Storage Engineer (GSE)
- Gas Storage Field Supervisor
- Gas Storage Field Personnel
- Gas Supervisors
- Gas Construction Services Personnel

4.0 General

4.1 This procedure provides guidelines to determine the temporary support methods of an in-service pipeline spanning a trench excavation.

4.2 The following groups are responsible for determining the temporary support of in-service piping:

4.2.1 Gas Region Engineering

1. Steel pipe with MAOP of 60 PSIG or less
2. PE pipe with MAOP of 125 PSIG or less.

4.2.2 Gas Tech Engineering

1. In-service steel pipeline with MAOP greater than 60 PSIG.

4.2.3 Gas Storage Engineering

1. In-service pipeline located within gas storage field or compressor station.

5.0 Support Method Table

5.1 Use Table 1 to determine the type of support method for a given span.

Table 1: Pipe Support Types vs Span

Pipe	Nominal Pipe Size	Span/Support Type
------	-------------------	-------------------

UNCONTROLLED IF PRINTED

		Under 5'	5'-10'	Over 10'
Welded Steel	Up to ¾"	--	A , E , F	B , C , E , F
	1 ¼" - 4"	--	A , E , F	C , D , E , F
	6" - 12"	--	--	C , D , E , F
	Over 12"	--	--	D , E
Coupled Steel (Threaded or Mechanical)	Up to ¾"	A , E , F	A , E , F	B , C , E , F
	1 ¼" - 4"	A , E , F	A , E , F	B , C , E , F
	6" - 12"	--	B , C , D	D
	Over 12"	--	C , D	D
Plastic	Up to 1 ⅛"	A , E , F	B , E , F	B , E , F
	1 ¼" - 4"	--	B , E , F	B , C , E , F
	6" - 8"	--	--	B , D , E , F

Notes:

- For A, B, C, D, E, F see [Section 6.0](#).
- "--" Not required

- 5.1.1 Reinforce exposed couplings in coupled steel lines or replace section with welded steel pipe.
- 5.1.2 If inserted cast iron or PVC pipe is involved, then contact GTE for further details.
- 5.1.3 Temporary support should remain in place until backfilled.
- 5.1.4 In backfilling, consider the use of rock shield to protect the pipe.
 1. Ensure the pipe is flat on compacted backfilled material and padded well with clean sand or fill dirt.
 2. Consider mechanical compaction to provide a firm support.
- 5.1.5 Keep weight of equipment off pipe until backfill is firmly installed beneath it.
- 5.1.6 The maximum span for steel pipe between supports is shown in Table 2.

Table 2: Maximum Span between Supports

Nominal Pipe Size	2"	3"	4"	6"	8"	10"	12"
Maximum Span	9'	11'	13'	16'	18'	20'	22'

Note: For steel pipe diameters not shown consult Gas Tech Engineering or Pipeline Toolbox Software Application, if available.

6.0 Temporary Support Methods

- 6.1 Type "A" Support (Figure 1)
 - 6.1.1 2" x 6" Timber
 - 6.1.2 Timber laid on edge beneath pipe
 - 6.1.3 Pipe Strapped

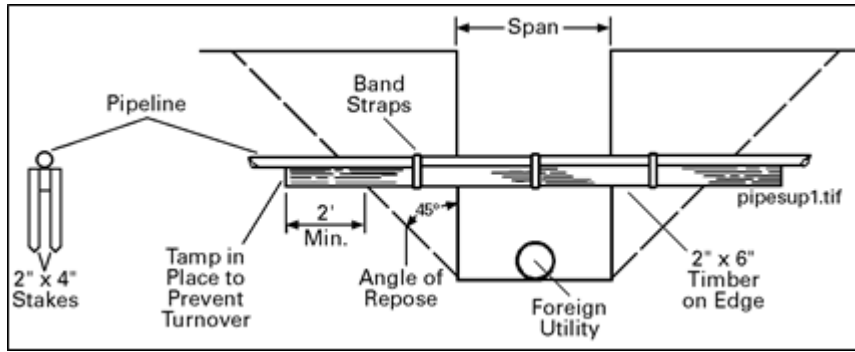

Figure 1: Type "A" Support

6.2 Type "B" Support (Figure 2)

6.2.1 "Vee" Trough Beneath Pipe

6.2.2 Pipe Strapped

6.2.3 Nail Trough Timbers Together

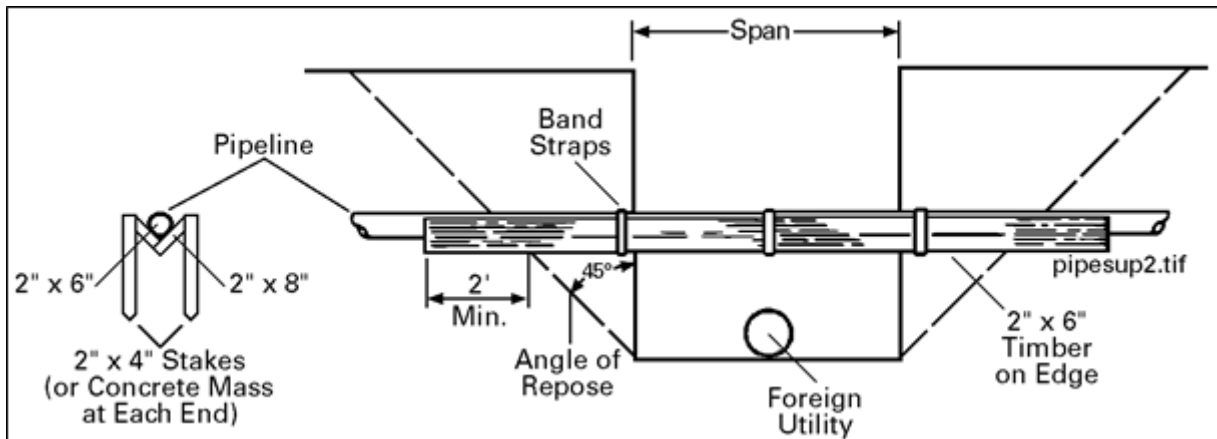

Figure 2: Type "B" Support

6.3 Type "C" Support (Figure 3)

6.3.1 Double Timbers (or Pole) Above Pipe

6.3.2 Cable Support

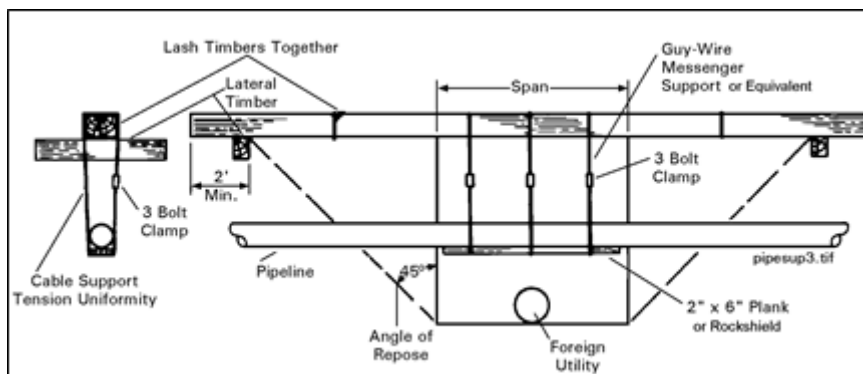

Figure 3: Type "C" Support

6.4 Type "D" Support (Figure 4)

6.4.1 Cribbing Beneath Pipe

6.4.2 4" x 4" x 3' Timbers

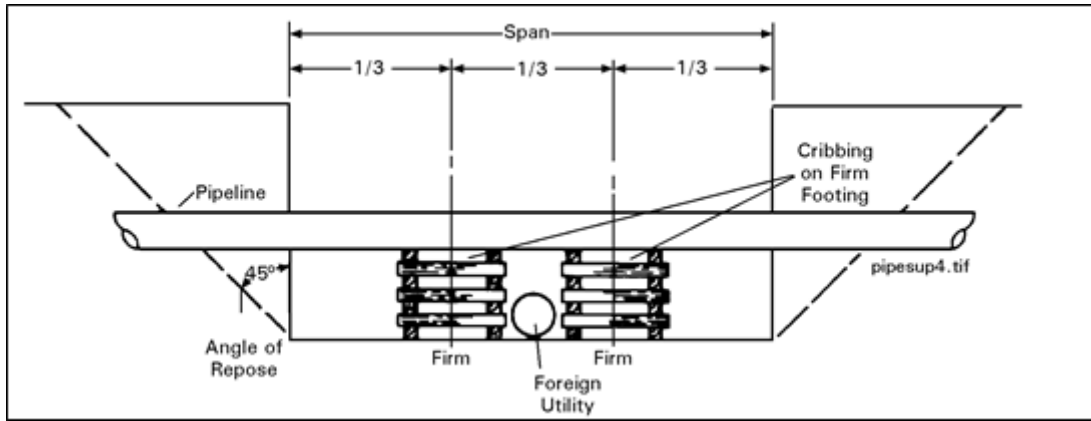

Figure 4: Type "D" Support

6.5 Type "E" Support

6.5.1 Sling Method of Pipe Support: Placement of slings should comply with the span lengths shown in [Table 2](#). Also see Figure 5.

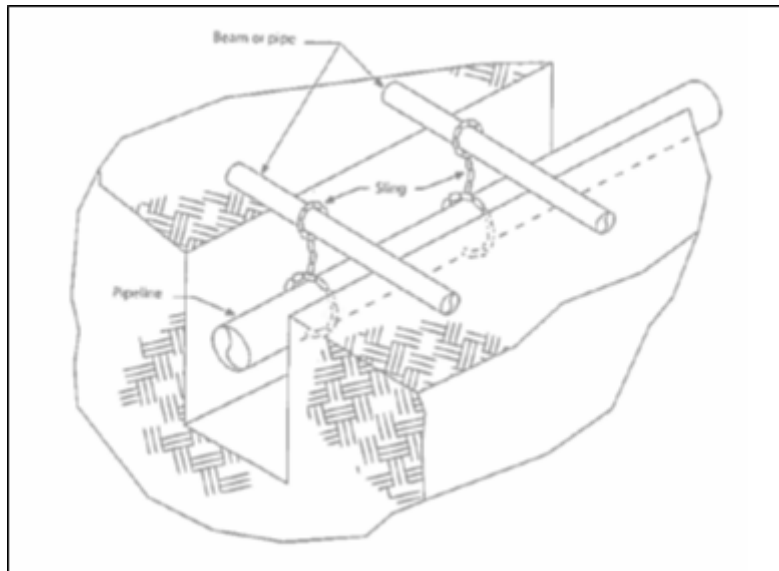

Figure 5: Sling Method of Pipe Support

6.6 Type "F" Support

6.6.1 Side boom/Backhoe Method of Pipe Support: Span lengths should comply with the span lengths shown in [Table 2](#). Also see Figure 6.

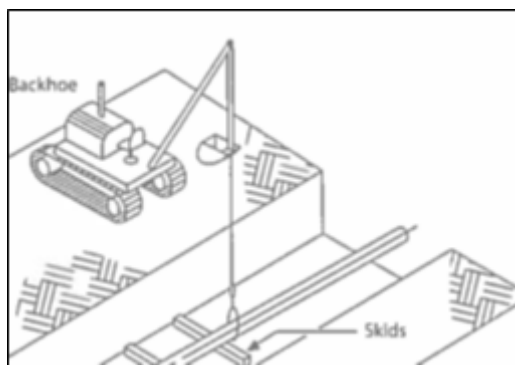

Figure 6: Side Boom/Backhoe Pipe Support

Due to the possibility of equipment hydraulic pressure bleed off, the rigging should be checked constantly.

6.7 Other

- 6.7.1 The use of other support methods are acceptable as long as the methods comply with the span lengths shown in [Table 2](#) and provide adequate support to eliminate undue stress on the pipe.
- 6.7.2 Other methods of temporary support shall be submitted to the appropriate engineering group, Region Engineer, GTE, or GSE for acceptance and approval.

End of Instructions.

Operator Qualification (OQ) Required?

YES

- 0151: Visual Inspection of Buried Pipe and Components when Exposed
- 0201: Visual Inspection of Buried Pipe and Components for Mechanical Damage
- 0211: Measure and Characterize Mechanical Damage on Installed Pipe and components
- 0301: Manually Opening and Closing Valves
- 0641: Visually Inspect Pipe and Components Prior to Installation
- 0861: Installation of Steel Pipe in a Ditch
- 0901: Installation of Plastic Pipe in a Ditch
- 0981: Backfilling
- 0991: Coating Application and Repair - Brushed or Rolled
- 1001: Coating Application and Repair - Sprayed
- 1011: External Coating Application and Repair - Wrapped
- 1291: Locate Underground Pipelines
- 1341: Provide or Assure Adequate Pipeline Support During Operator Initiated Excavation Activities

Appendices

NONE.

Attachments

NONE.

Compliance Requirements

49 CFR §192.161 Supports and anchors.

Reference Documents

NONE

UNCONTROLLED IF PRINTED

Document Rescission

MAIN 2.4 MAIN Installation: Temporary Pipeline Support, October 1, 2020

Revision Notes

Location of Changes	Summary of Changes
Paragraph 4.2.1	Updated – Gas Region Engineering replaces Gas Division Engineering.
Paragraph 4.2.1 – Item 2	Updated – Responsible for PE pipe having Design MAOP of 125 psig.

MAIN INSTALLATION

May 15, 2022

MAIN 2.5 Pipe Coating and Gasket Removal

1.0 Purpose

This document describes the procedures to be used when removing and disposing of:

- Coal tar pipe coating that contains or potentially contains asbestos or low concentration of PCBs
- Flange gaskets suspected of containing asbestos.

These procedures meet the requirements of 49 CFR §§ 192.911, 173.6, 173.216, and 29 CFR §1926.110.

2.0 Scope

This document addresses the following:

[3.0 Target Audience](#)

[4.0 General](#)

[5.0 Sample Testing](#)

[6.0 Notifications](#)

[7.0 Inspections](#)

[8.0 Personal Protective Equipment, Other Equipment, Materials, Tools](#)

[9.0 Pipe Wrap and Gasket Removal Procedures](#)

[10.0 Waste Transportation](#)

[11.0 Collection and Storage for Disposal](#)

Appendices

[Appendix A - PPE, Material, and Equipment](#)

3.0 Target Audience

- Gas Engineering
- Gas Distribution Design Specialist
- Field Engineering Representatives
- Gas Tech Services (GTS) Personnel
- Gas Tech Services (GTS) Supervisors
- Gas Field Personnel
- Gas Supervisors
- Gas Construction Services Personnel

4.0 General

4.1 The pipe wrap removal procedures listed only apply if the material is able to be removed intact.

4.1.1 "*Intact*" is defined by OSHA as Asbestos Containing Material (ACM) that "*has not crumbled, been pulverized, or otherwise deteriorated so that the asbestos is no longer likely to be bound within its matrix.*"



The work practices specified in this procedure normally will keep the materials intact.

- 4.1.2 ACM not able to be removed intact must be performed by a licensed asbestos abatement contractor.
- 4.1.3 Contact an Ameren Illinois Safety Supervisor to arrange for a contractor, if required.
- 4.2 All workers involved in the removal or handling of asbestos-containing coal tar pipe wrap and/or asbestos-containing gaskets shall receive the appropriate training prior to performing any such work.
 - 4.2.1 This training consists of Asbestos Pipe Wrap Worker and Class III Operations & Maintenance training for gasket removal.
 - 4.2.2 Refresher training shall be provided annually.

5.0 Sample Testing

- 5.1 When encountering coal tar coated pipe, assume the material contains asbestos and Polychlorinated biphenyls (PCB).
 - 5.1.1 The work shall be performed in accordance with this procedure.
 - 5.1.2 If the material is sampled and found to be negative for asbestos the work can be performed without asbestos-related precautions in handling of the coating material.
- 5.2 The gaskets in Table 1 do not contain asbestos. They do not require asbestos-related precautions when handling or removing.

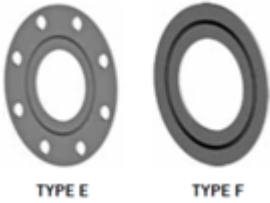
Table 1: Asbestos-Free Gaskets

G.F. Central Plastic Jock O-Ring	 <p>TYPE E TYPE F</p>
Garlock Style 5500 Inorganic Fiber Gasket	
Garlock Blue-Gard	
TherMOSeal (Flexitallic Gaskets)	"Klinger SIL " gaskets do not contain asbestos.

UNCONTROLLED IF PRINTED

Thermoseal (Flexitallic) gaskets labeled "Klinge**RIT**" contain asbestos.

- 5.3 Assume that all other gaskets contain asbestos and shall be handled in accordance with this procedure, unless the gasket is sampled and found to be negative for asbestos.
- 5.4 If Ameren Illinois (AIC) requests a sample to be analyzed for asbestos, it shall be collected by an Inspector who is licensed by the Illinois Department of Public Health.
 - 5.4.1 Contact an AIC Safety Supervisor to arrange for an inspection.
- 5.5 Assume coal tar pipe coatings contains PCB's for disposal unless the material is sampled and analyzed for PCBs.
 - 5.5.1 Contact Corporate Environmental if necessary, to arrange for testing.

6.0 Notifications

- 6.1 For projects where the threshold quantity of 260 linear feet, 260 square feet, or 1 cubic meter of friable ACM may be exceeded, written notification to Illinois EPA shall be made at least 10 working days prior to start of the project.

When calculating the threshold quantity, include only pipe wrap that has been removed to facilitate removal of the pipe (i.e., to cut the pipe in sections) OR has been damaged during the removal process.

- 6.2 If field personnel anticipate the job will impact significantly more materials than previously estimated and possibly exceed the threshold amount, then contact the AIC Safety Supervisor so that any required regulatory notifications can be made.

7.0 Inspections

- 7.1 A designated Pipe Wrap Competent Person must examine the materials to be removed, and determine whether it is "intact", as defined in [Section 4.1.1](#).
 - 7.1.1 If the material is not intact, (or anytime during the work the material is identified as non-intact) then removal will be performed by a licensed asbestos abatement contractor.
 1. Cover the non-intact pipe wrap with plastic sheeting, mark-off the impacted area, and instruct personnel to stay out of that area.
 2. Contact AIC Safety Supervisor to have arrangements made for a licensed asbestos abatement contractor.
- 7.2 If a pipeline operating over 100 psig is exposed and its coating has become disbonded, bubbled, distorted, or is in very poor condition, then notify Pipeline Integrity personnel for instructions prior to removal. See Figures 1 and 2.

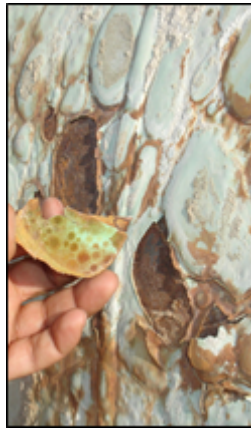

Figure 1: Bubbled or Blistered coating



Figure 2: Disbonded Coating

7.2.1 See [FORW Section 5.0](#) for contact information.

7.2.2 The Pipeline Integrity personnel may need to conduct an integrity examination for moisture, pH, and pipe condition before work continues.

7.3 The Pipe Wrap Competent Person shall also perform periodic inspections (at least daily) to ensure that the appropriate work practices are being followed.

8.0 Personal Protective Equipment, Other Equipment, Materials, Tools

8.1 The table in [Appendix A](#) provides the stock numbers and descriptions for the PPE, materials, and equipment that may be required for the removal and disposal asbestos containing coal tar/gaskets.

8.2 PPE for asbestos-containing pipe wrap or gaskets removal:

8.2.1 Standard work PPE:

1. Hardhat
2. Safety glasses
3. Safety-toed boots
4. Work gloves, etc.

8.2.2 Disposable flame resistant/retardant (FR) coveralls are available and may be worn to keep the pipe coating or gasket material off of clothes.

8.2.3 Respiratory protection is not required during removal of intact pipe wrap, provided the required work practices are followed.

UNCONTROLLED IF PRINTED

1. Employees may choose to wear a half-face, tight-fitting respirator equipped with P100 filters, provided they are medically qualified and have the appropriate respirator fit test.
2. Employees may also choose to wear a dust mask for comfort from general airborne dust.
3. If there is any doubt about an operation or exposures, contact AIC Safety Supervisor.

8.2.4 If the work to be performed requires Level I or Level II PPE per [WIGE 2.2](#), no additional PPE is required.

8.3 The following equipment, materials, and tools are required for asbestos-containing pipe wrap or gaskets removal:

8.3.1 A water solution to which surfactant (wetting agent) has been added to increase the ability of the liquid to penetrate ACM, such as:

1. Leak detection fluid
2. Soap and water solution

8.3.2 Pump spray bottle for amended water solution

8.3.3 Plastic bags, 6 mil minimum thickness.

8.3.4 Plastic sheeting, 6 mil minimum thickness.

8.3.5 Thin-film plastic wrap (i.e., "saran" wrap or shrink wrap, for pipe wrap removal)

8.3.6 Duct tape

8.3.7 Hammer/mallet, scraper, chisel, putty knife, sharp knife or machete

8.3.8 Solvent

8.3.9 Abrasive pads or metal file

8.3.10 Rags

8.3.11 Asbestos waste labels,

8.3.12 For gasket removal:

1. Caution tape
2. Asbestos warning signs

9.0 Pipe Wrap and Gasket Removal Procedures

9.1 All asbestos-containing gasket removal must be performed within a "Regulated Area" that is designated using asbestos warning sign and, if necessary, caution tape.

The use of power tools, grinders, and sanders, or other mechanical equipment or burning is strictly prohibited on asbestos-containing coating or gaskets.

9.2 When exposing or removing the pipe or other buried facility containing pipe wrap, take care to minimize damage to the pipe wrap.

9.3 Put on personal protective equipment.

- 9.4 Place plastic sheeting under the portion of the pipe where coal tar wrap or gasket is to be removed.
- 9.5 Wet the coal tar coating with an amended water solution. Leak detection fluid may be used.
 - 9.5.1 Keep the coating wet during removal.
 - 9.5.2 If necessary, use a sharp knife or other cutting tool to score the coating, to aid in the removal.
 - 9.5.3 To assist in containing the coal tar pipe coating to be removed, it is recommended to wrap with a thin film plastic wrap if feasible.
 - 9.5.4 Remove the coal tar coating with hammer to break the coating into large pieces.
 - 9.5.5 Once the majority of the coating is broken away from the pipe, cut the thin film plastic wrap along the top, allowing the material to drop onto the plastic sheeting on the ground.
 - 9.5.6 Use a scraper, putty knife or similar tool to complete removal.
 - 9.5.7 Use a solvent or amended water solution and abrasive pad/file to manually remove remaining residual coating material as needed.
- 9.6 Wet the gasket with an amended water solution. Leak detection fluid may be used.
 - 9.6.1 The gasket shall be kept wet during removal.
 - 9.6.2 Remove gaskets with scraper or other tool.
 - 9.6.3 Use a solvent or amended water solution and abrasive pad/file to manually remove remaining residual gasket material.
- 9.7 After coating or gasket has been removed, wipe pipe or flange surface down with wet rags/towels.
- 9.8 Once removal of the coal tar coating, or gasket is completed, ensure all pieces and any rags/towels used are on the plastic sheeting or in a plastic bag.
 - 9.8.1 Roll up the plastic sheeting.
 - 9.8.2 Secure with duct tape.
 - 9.8.3 Place the plastic into an asbestos labeled 6 mil (minimum) plastic bag.
- 9.9 Where sections of pipe are being removed, the pipe wrap on the remaining pipe should be cleared of all loose pieces prior to moving the pipe.
- 9.10 Removed section of pipe should be:
 - 9.10.1 Wrapped with a minimum 6 mil plastic sheeting, sealed with tape and labeled with the asbestos waste label (See [Figure 3](#)).
 - or
 - 9.10.2 Placed directly into a 6 mil plastic lined bin. The plastic must be sealed with tape at the end of the day and labeled with the asbestos waste label.



Figure 3 Asbestos Waste Labels

9.11 Perform clean-up according to the following:

- 9.11.1 Disposable wet wipes or wet rags should be used for wiping off tools and equipment, including Level I or Level II PPE, used during the removal.
- 9.11.2 Place all disposable items into the asbestos labeled plastic bag.
- 9.11.3 Remove disposable PPE, place in the asbestos labeled plastic bag and seal with duct tape
- 9.11.4 Wash hands, and face and arms as necessary.

10.0 Waste Transportation

10.1 All asbestos waste materials must be transported in accordance with DOT regulations.

10.2 Transportation of small quantities, less than 440 pounds, of asbestos waste may be transported in a sealed container/bag to the designated "Asbestos Storage for Disposal" (ASD) location without DOT placards or shipping manifests. See Figure 4. Refer to 49 CFR §173.6 (d).

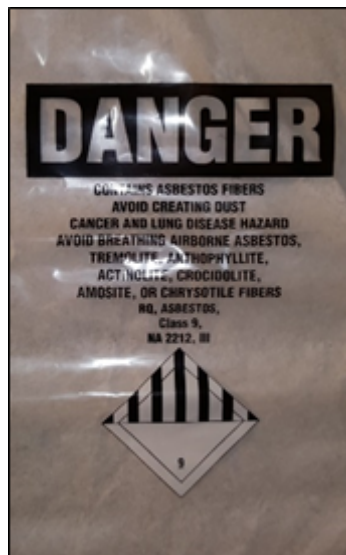

Figure 4 Asbestos Waste Bag

11.0 Collection and Storage for Disposal

- 11.1 Removed asbestos waste will be stored at a designated ASD location or stored temporarily on site in an approved disposal container pending laboratory analysis, and then transported to an approved disposal site.
- 11.2 Bags of asbestos waste shall be placed in open-top 55-gallon drums.

UNCONTROLLED IF PRINTED

11.2.1 Each drum shall be appropriately labeled.

11.2.2 The lids for all drums containing asbestos wastes shall be kept closed except when in the process of adding more waste.

11.3 Large items of asbestos waste, appropriately wrapped in plastic and labeled, that cannot be placed in drums shall be placed on the ground within the ASD location.

11.4 Stores personnel shall be notified when drums are full or large items are ready for pick-up. Stores will then contact Ameren Corporate Environmental Services to make arrangements for pick-up.

End of Instructions.

Operator Qualification (OQ) Required?

YES

0991 Coating Application and Repair - Brushed or Rolled

1001 Coating Application and Repair - Sprayed

1011 External Coating Application and Repair - Wrapped

Appendices

[Appendix A - PPE, Material, and Equipment](#)

Attachments

NONE.

Compliance Requirements

29 CFR §1926.110 Asbestos

49 CFR §173.6 Materials of trade exceptions.

49 CFR §173.216 Asbestos, blue, brown or white.

49 CFR §192.911 What are the elements of an integrity management program?

Reference Documents

[FORW Forward - Section 5 Contacts](#)

[WIGE 2.2 Working In Gaseous Environment: Personal Protective Equipment](#)

Document Rescission



MAIN 2.5 Main Installation: Pipe Coating and Gasket Removal, December 1, 2020

Revision Notes



Location of Changes	Summary of Changes
Reference Documents	Updated – WIGE replaces WWBG
Appendix A - PPE	Updated Stock Codes for Gloves – North NF11: red, vinyl-coated palms. Deleted the XS size.

UNCONTROLLED IF PRINTED

Appendix A - PPE, Material & Equipment

Item	Size	Stock #	Pictures/Comments
Disposable Tyvek coveralls (white, 25/case).	M	49-35-108	
	L	49-35-109	
	XL	15-51-420	
	2X	15-51-494	
	3X	15-51-748	
	4X	15-51-747	
Disposable FR coveralls (light blue and come with a hood, 25/case)	XL	49-25-147	
	2XL	49-25-148	
	3XL	49-25-149	
	4XL	49-25-150	
Gloves - North NF11 (red, vinyl-coated palms)	S	49 45 379	
	M	49 45 370	
	L	49 45 380	
	XL	49 45 381	
	2X	49 45 382	
1/2 Face Respirator - 3M 6200	Medium	49-15-540	
1/2 Face Respirator - 3M 6300	Large	49-15-535	
Respirator Cartridges, P100 - 3M 6001 (2/pkg)		49-15-963	
Caution Tape, yellow, roll ("CAUTION")	3" x 1000'	16-06-770	
"Danger - Asbestos" sign (for Regulated Area for gaskets)	5" X 7"	16-02-363	
Leak Detection Fluid (to use as amended water solution)	1 Gallon	49-17-190	
Sprayer, plastic bottle with trigger, for amended water solution	22 oz.	15-52-670	
Hudson sprayer #60183, for amended water solution	3 Gallons	49-25-154	
Solvent for residue removal: Parts Kleen aerosol Citrus Solv		15-51-666 15-52-881	Not currently stocked at MDF: need to field-verify effectiveness.

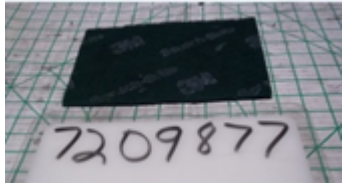
UNCONTROLLED IF PRINTED

Abrasive scouring pads	6" x 9"	72-09-877	
Clear poly sheeting roll - 6 mil, for waste containment	10' X 100'	49-06-201	
Thin plastic sheeting, roll, for pre-wrapping pipe	15" X 1,000'	49-03-202	
Asbestos disposal bags, plastic 6 mil, (50/roll)	38" X 60"	49-17-979	
Asbestos disposal bags, plastic 6 mil, (250/box)	24" X 24"	49-25-153	
Asbestos waste labels, vinyl-coated. (100/roll)	4" X 4"	16-04-576	
Asbestos waste labels	3" x 5"	16-04-900	
Asbestos waste labels, paper (individual labels)	2½ x 3½	16-04-166	
Open-top waste drum	55 gal.	22-08-252	
Waterless cleaner		15-52-707	
Tough Towels (150 sheets/container)	10½" X 12"	15-52-604	

1.0 Purpose

This procedure provides information on the insertion of PE main through abandoned gas mains or previously installed conduits. This procedure meets the requirements on 49 CFR §192.321.

2.0 Scope

This document addresses the following:

[3.0 Target Audience](#)

[4.0 General](#)

[5.0 Considerations](#)

[6.0 Planning](#)

[7.0 Tracer Wire Installation](#)

[8.0 Insertion Procedures](#)

[9.0 Conduit or Sleeve Insertion Procedures](#)

3.0 Target Audience

- Gas Engineering
- Gas Distribution Design Specialist
- Field Engineering Representatives
- Gas Field Personnel
- Gas Supervisors
- Gas Construction Services Personnel

4.0 General

4.1 There are two insertion scenario presented in this section:

4.1.1. Insertion of PE main through an abandoned gas main, and

4.1.2. Insertion of PE main through a previously installed non-metallic conduit.

4.2 Main insertion through abandoned gas main should only be performed with Supervising Engineer approval.

4.2.1. In these procedures the existing main to be abandoned will be referred to as conduit.

4.2.2. Replacement projects involving PE pipe main insertion through multiple segments of abandoned gas main require an Engineering review.

4.3 PE main can be inserted through a previously installed non-metallic conduit:

4.3.1. Under such hard surfaces; as roadways, driveways or parking lots.

4.3.2. In excavations to protect PE pipe from rock impingement.

4.4 New main shall not be inserted through any abandoned main or non-metallic conduit that does not meet the depth requirements as outlined in [MAIN 1](#).

4.5 PE mains inserted under highways, railroads or rivers shall be in accordance with permit requirements. Refer to [STLP 2.1](#) Casing Pipe Installation

5.0 Considerations

- 5.1 PE main insertion should be limited due to the difficulty of leak detection and installation of new service tee.
- 5.2 Inserting more than one block at a time should be avoid, if possible.
- 5.3 Existing line valve within the abandoned pipe segment should be removed or made inoperable by removing the operator prior to insertion.

6.0 Planning

- 6.1 Insertion of main may involve service disruption for multiple customers at one time.
 - 6.1.1. Plan each segment of insertion to minimize customer outages.
 - 6.1.2. Coordination between Ameren Illinois (AIC) crews and customers is essential as well as coordination among multiple crews working the same job.
 - 6.1.3. Notify customers well in advance of project date, so that any special needs by an individual customer can be addressed.
- 6.2 When engineering the project, ensure that guidance is provided as to which facilities will be inserted and which customers will be impacted.
- 6.3 An engineering insertion plan with written project specific procedures are need when inserting through multiply sections of abandoned gas main to be developed for each segment of insertion. The plan should indicate such items as:
 - 6.3.1. One-way feeds
 - 6.3.2. *Two-way feeds*
 - 6.3.3. *Different pressure systems*
 - 6.3.4. *Detail for each tie in*
 - 6.3.5. *Service lines to replace or tie-over*
- 6.4 Prior to beginning the project, the Gas Supervisor or Engineer shall review the plan for each segment in detail with crews.

7.0 Tracer Wire Installation

- 7.1 An approved tracer wire listed in Table 1 shall be pulled through the abandoned pipe with the new inserted pipe.

#14 solid soft drawn copper tracer wire, 18 66 677, is not approved for main insertion.

- 7.2 The tracer wire from inserted PE main shall be connected to the tracer wire of the existing PE main as required in [CORR 2.1 Section 7.0](#).
- 7.3 See [CORR 2.1 Section 7.0](#) for bonding recommendations at tie-in points to active steel mains.

Table 1 Approved Tracer Wire

Stock Code	Description	Spool Length	Tensile Strength
18 66 208	#12 Solid Soft Drawn Copper	500 ft.	198 lbs.

18 66 369	#12 Solid Soft Drawn Copper	1,500 ft.	198 lbs.
18 52 049	#10 Stainless Steel Stranded	530 ft.	1,260 lbs.
18 52 050	#10 Stainless Steel Stranded	1,000 ft.	1,260 lbs.

8.0 Insertion Procedures

- 8.1 Customers should be given prior notification that there will be service interruption.
- 8.2 To reduce customer down time, fuse together as much of the inserted PE pipe as possible before disconnecting any customers.
- 8.3 Following the insertion plan ([Section 6.3](#)), excavate at each end of the main to be inserted and at all proposed service tee locations.
- 8.4 Locate all valves necessary to isolate the section to be abandoned. If valves are not available, then identify location for line stopper fittings or squeeze offs, as necessary.
- 8.5 Turn off and lock the gas meter valve at each affected customer.
- 8.6 Isolate the main to be abandoned with the designated valves, line stopper fittings or squeeze offs.
- 8.7 Purge the segment to be abandoned according to [PURG 2](#) Purging: Methods.
- 8.8 Remove abandoned pipe sections at the tie-in locations leaving sufficient space for inserting the new main and making tie-ins.
- 8.9 Remove a segment of the abandoned pipe at the location of each proposed service tap.
- 8.10 Inspect all openings and remove burrs or sharp edges, which could damage the main as it is being inserted. Tools such as a pipe reamer, power grinder or file can be used to smooth the edges of the abandoned pipe.
- 8.11 Pull additional length of PE pipe through the abandoned pipe to inspect for damage. If the pipe is damaged then:
 - 8.11.1 Remove the inserted main.
 - 8.11.2 Inspect for cause of damage and make necessary corrections.
 - 8.11.3 Do not reuse the damaged pipe from the previous insertion.
 - 8.11.4 If multiple attempts at insertion have resulted in damage to the main, do not use the abandoned pipe as a casing.
- 8.12 When inserting coiled pipe, a section of straight pipe should be fused on to the leading end. An approved weak link shall be used if the main is to be pulled during the insertion. See [POLY 2.3](#) Polyethylene Pipe: Installation Requirements.
- 8.13 Plug the leading end of the main to prevent debris from entering the pipe.
- 8.14 Pad all locations where the main is entering and exiting the abandoned pipe to provide protection of the main during insertion.
 - 8.14.1 Protection methods may include:
 1. PE protector inserts
 2. Split pieces of PE pipe
 3. Tuff-N-Nuff rock shield. See [MAIN 1 Appendix A](#).
 4. Safety Wrap See [DAMG 1 Section 8.0](#).
 5. Link seals - See [STLP 2.1 Section 6.0](#).

UNCONTROLLED IF PRINTED

6. Preformed FRP Spacer - See [CORR 2.7 Subsection 12.3](#).

- 8.15 Insert main into the abandoned pipe and inspect the main and tracer wire for damage as it passes through cut out openings.
- 8.16 Make a final inspection of the inserted main, the leading edge and at all cutout openings in the conduit.
- 8.17 Fabricate any necessary piping for tie-ins on each end of the main.
- 8.18 Secure the protection methods in place by such means as tape, glue, adhesive or sealant.
- 8.19 Pressure test the inserted main as required in [PTST 1](#).
- 8.20 Tie-in the inserted main to the existing mains on either end of the job.
- 8.21 Introduce gas into the main and purge in accordance with [PURG 2](#) Purging: Methods.
- 8.22 Connect tested services to the inserted main.
 - 8.22.1. Purge service line.
 - 8.22.2. Reinstate service to customer.
- 8.23 Backfill as required in [MAIN 1](#). Compacted backfill under the exposed sections of the inserted main providing support to prevent possible shear points.
- 8.24 The inserted main shall be identified with sufficient information on the job As-Built construction plans that the location can designated in the AIC electronic mapping system.

9.0 Conduit or Sleeve Insertion Procedures (49 CFR §192.321)

- 9.1 Expose each end of the non- metallic conduit.
- 9.2 Ensure conduit is free of debris and the openings' edges are smooth.
- 9.3 Seal the leading end of PE pipe.
- 9.4 Insert the PE pipe and tracer wire through the conduit.
- 9.5 Pull additional length of PE pipe through and inspect the pipe for damage.
 - 9.5.1 If the pipe is damaged, remove the inserted pipe.
 - 9.5.2 Investigate the cause for the damage and correct if possible.

Do not reuse any damaged pipe from a previous insertion attempt.

- 9.5.3 Insert the main again and check for damage.
- 9.5.4 If the cause of the damage cannot be corrected, do not use the conduit
- 9.6 Seal both ends of the main until it is permanently tied-in using approved connections and fittings. See [POLY 2.5](#) Electrofusion or [POLY 2.4](#) Butt Fusion.
- 9.7 Compact the backfill material at the ends of the conduit to provide support for the main and to prevent the creation of a shear point.
- 9.8 Following table shows the minimum inside diameter (ID) of the conduit in which the PE main should be inserted.

Recommended Conduit Size

UNCONTROLLED IF PRINTED

Inserted Main Size	Minimum Conduit Size
2" IPS	4" ID
4" IPS	6" ID
6" IPS	8" ID
8" IPS	10" ID

9.9 The inserted section of main shall be identified on the job As-Built construction plans with sufficient information that the location can be designated in the AIC electronic mapping system.

End of Instructions.

Operator Qualification (OQ) Required?

YES

- 0041: Installation and Maintenance of Mechanical Electrical Connections
- 0051: Installation of Exothermic Electrical Connections
- 0061: Inspect or Test Cathodic Protection Bonds
- 0201: Visual Inspection of Installed Pipe and Components for Mechanical Damage
- 0301: Manually Opening and Closing Valves
- 0561: Pressure Test - Nonliquid Medium- MAOP Less than 100 Psi
- 0571: Pressure Test - Nonliquid Medium- MAOP Greater than or Equal to 100 PSI
- 0591: Leak Test at Operating Pressure
- 0641: Visually Inspect Pipe and Components Prior to Installation
- 0751: Joining of Plastic Pipe - Butt Heat Fusion: Manual
- 0761: Joining of Plastic Pipe - Butt Heat Fusion: Hydraulic Machine
- 0781: Joining of Plastic Pipe - Electrofusion
- 0801: Welding
- 0811: Visual Inspection of Welding and Welds
- 0861: Installation of Steel Pipe in a Ditch
- 0901: Installation of Plastic Pipe in a Ditch
- 0941: Install Tracer Wire
- 0951: Installation of Pipe Above Ground
- 0971: Installation and Maintenance of Casing Spacers, Vents and Seals
- 0981: Backfilling
- 0991: Coating Application and Repair - Brushed or Rolled
- 1001: Coating Application and Repair - Sprayed
- 1011: External Coating Application and Repair - Wrapped

UNCONTROLLED IF PRINTED

- 1081: Tapping a Pipeline (Tap Diameter 2 Inch or Less)
- 1091: Tapping a Pipeline (Tap Diameter Greater Than 2 Inch)
- 1101: Tapping a Pipeline with a Built-In Cutter
- 1131: Stopper (Stopp) Pipe
- 1141: Squeeze Off Plastic Pipe
- 1161: Installation of Customer Meters and Regulators - Residential and Small Commercial
- 1191: Maintenance of Service Valves Upstream of Customer Meter
- 1201: Temporary Isolation of Service Lines and Service Discontinuance
- 1291: Locate Underground Pipelines
- A001: Service Reconnect

Appendices

NONE.

Attachments

NONE.

Compliance Requirements

49 CFR §192.321 Installation of plastic pipe.

49 CFR §192.311 Repair of plastic pipe.

Reference Documents

[CORR 2.1 Corrosion Control: Cathodic Protection Design](#)

[MAIN 1 Main Installation: Requirements](#)

[POLY 1 Polyethylene Pipe: Requirements](#)

[PTST 1 Pressure Testing: Requirements](#)

[PURG 2 Purging: Methods](#)

Document Rescission

MAIN 2.06 Main Installation: Insertion, April 1, 2019.

Revision Notes

Location of Changes	Summary of Changes
Not applicable.	This is a new document.

1.0 Purpose

This procedure provides installation and material requirements for lateral taps.

2.0 Scope

This document addresses the following:

[3.0 Target Audience](#)

[4.0 PE Tees to PE Pipe](#)

[5.0 Steel Tees to PE Pipe](#)

[6.0 Steel Tees to Steel Pipe](#)

Appendices

[Appendix A - PE Tees to PE Pipe](#)

[Appendix B - Steel Tees to PE Pipe](#)

[Appendix C - Steel Tees to Steel Pipe](#)

3.0 Target Audience

- Gas Engineering
- Gas Distribution Design Specialist
- Field Engineering Representatives
- Gas Field Personnel
- Gas Supervisors
- Gas Construction Services Personnel

4.0 PE Tees to PE Pipe

- 4.1 High Volume Tee (See [Appendix A-1](#))
- 4.2 Inline Tee (See [Appendix A-2](#))
- 4.3 TDW Sidetap (See [Appendix A-3](#))

5.0 Steel Tees to PE Pipe

- 5.1 Mueller Tee: Steel to PE Pipe (See [Appendix B-1](#))
- 5.2 Mueller Curb Valve Tee: Steel to PE Pipe (See [Appendix B-2](#))
- 5.3 Mueller Bottom Out Tee: Steel to PE Pipe (See [Appendix B-3](#))
- 5.4 TDW Tee: Steel to PE Pipe (See [Appendix B-4](#))

6.0 Steel Tees to Steel Pipe

- 6.1 Mueller Tee (See [Appendix C-1](#))
- 6.2 Mueller Curb Valve Tee (See [Appendix C-2](#))
- 6.3 Mueller Bottom Out (See [Appendix C-3](#))
- 6.4 TDW Tee (See [Appendix C-4](#))

End of Instructions.

Operator Qualification (OQ) Required?

YES

- 0641: Visually Inspect Pipe and Components Prior to Installation
- 0681: Joining of Plastic Pipe - Stab Fittings
- 0751: Joining of Plastic Pipe - Butt Heat Fusion: Manual
- 0761: Joining of Plastic Pipe - Butt Heat Fusion: Hydraulic Machine
- 0781: Joining of Plastic Pipe - Electrofusion
- 0801: Welding

Appendices

- [Appendix A - PE Tees to PE Pipe](#)
- [Appendix B - Steel Tees to PE Pipe](#)
- [Appendix C - Steel Tees to Steel Pipe](#)

Attachments

NONE.

Compliance Requirements

NONE.

Reference Documents

- [TAPS 2.4 Tapping and Stopping: Mueller Tapping and Stopping Procedure](#)
- [TAPS 2.5 Tapping and Stopping: T.D. Williamson Tapping and Stopping Procedure](#)

Document Rescission

MAIN 3.1 Main Installation: Lateral Tap, April 1, 2021.

Revision Notes

Location of Changes	Summary of Changes
Subsection 5.2	Added "Curb" – Mueller Curb Valve Tee to PE Pipe
Subsection 6.2	Added "Curb" – Mueller Curb Valve Tee
Appendix B – B.2.1.1	Mueller Valve Tee, 19 33 562, may be substituted for the curb valve tee.
Appendix B – B-2 Mueller Valve Tee – Table 9 & 10	Updated stock code for Box, Curb, For 2" Valve Tee. Updated description for Tee, Steel, Curb Valve, 2", 1440 psig, with 2" x 2" Square Head
Appendix B – B-3 Mueller Bottom-Out Tees – Table 11 12	Change pressure rating form 2" Line Stopper to 250 psig Updated Stock Code for 6" Weld Inline Tee.

Appendix C – C-2 Mueller Curb Valve Tee – C-2.1.3	Mueller Valve Tee may be substituted for curb valve tee
Appendix C – C-2 Mueller Curb Valve Tee – Table 16	Updated stock code for Box, Curb, For 2" Valve Tee. Updated description for Tee, Steel, Curb Valve, 2", 1440 psig, with 2" x 2" Square Head
Appendix C – C-3 Mueller Bottom-Out Tee – Table 17	Change pressure rating form 2" Line Stopper to 250 psig Updated Stock Code for 4' and 6" Weld Inline Tee.

Appendix A, PE Tees to PE Pipe

A-1. High Volume Tee (See [Figure 1](#))

A-1.1 Installation

A-1.1.1 Connect new tracer wire to existing tracer wire.

A-1.1.2 Lateral connection shall be electrofusion or butt fusion.

A-1.2 Approved materials are listed in [Table 1](#) and [Table 2](#).

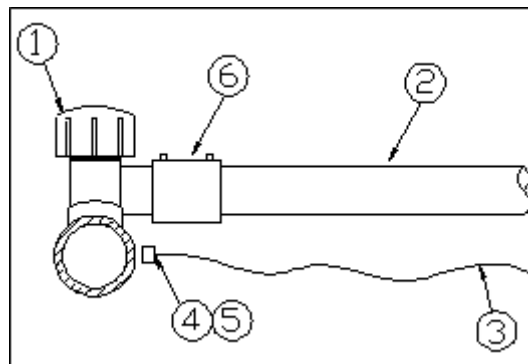

Figure 1
High Volume Tee

Table 1
High Volume Tee - Medium Density PE Pipe

PE2406/PE2708 - Medium Density PE Pipe - (Yellow) (G2113 ##)						
Item	Stock No.	Description	Quantity			
			22	32	42	62
1	19 22 412	Tee, Service, Electrofusion, 2" X 2", PE3408/PE4710	1			
	19 22 413	Tee, Service, Electrofusion, 3" X 2", PE3408/PE4710		1		
	19 22 414	Tee, Service, Electrofusion, 4" X 2", PE3408/PE4710			1	
	19 22 415	Tee, Service, Electrofusion, 6" X 2", PE3408/PE4710				1
2	32 05 001	Pipe, PE2406/PE2708, 2"	X	X	X	X
3	18 66 369	Wire Detector, # 12 AWG, TW, Cu.	X	X	X	X
4	17 54 842	Connector, Split Bolt, Copper, #16 to #10	1	1	1	1
5	49 62 001	Box, Splice, Plastic	1	1	1	1

6	19 22 278	Coupling, 2", Electrofusion, PE3408/PE4710	1	1	1	1
---	-----------	--	---	---	---	---

X - Number of feet required for specific installation.

Table 2
High Volume Tee - High Density PE Pipe

PE3408/PE4710 - High Density PE Pipe - (Black) (G2213 ##)						
Item	Stock No.	Description	Quantity			
			22	42	62	
1	19 22 412	Tee, Service, Electrofusion, 2" X 2", PE3408/PE4710	1			
	19 22 414	Tee, Service, Electrofusion, 4" X 2", PE3408/PE4710		1		
	19 22 415	Tee, Service, Electrofusion, 6" X 2", PE3408/PE4710			1	
2	32 22 031	Pipe, PE3408/PE4710, 2"	X	X	X	
3	18 66 369	Wire Detector, # 12 AWG, TW, Cu.	X	X	X	
4	17 54 842	Connector, Split Bolt, Copper, #16 to #10	1	1	1	
5	49 62 001	Box, Splice, Plastic	1	1	1	

X - Number of feet required for specific installation.

A-2. Inline Tee (See [Figure 2](#) and [Figure 3](#))

A-2.1 Installation

A-2.1.1 Connect new tracer wire to existing tracer wire.

A-2.1.2 Lateral connection shall be electrofusion or butt fusion.

A-2.1.3 It may be necessary to build a by-pass to prevent loss of service if the existing main does not have multiple feeds.

A-2.2 Approved materials are listed in [Table 3](#) and [Table 4](#).

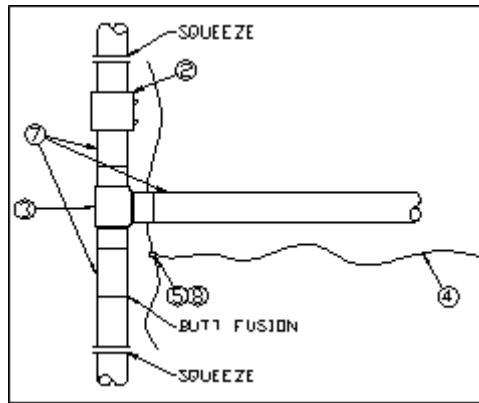

Figure 2
In-line Tee

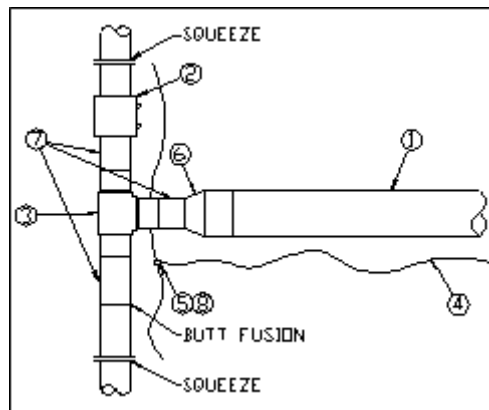

Figure 3
In-line Tee with reducer

Table 3
In-line Tee - Medium Density PE Pipe

PE2406/PE2708 - Medium Density PE Pipe - (Yellow) (G2123 ##)											
Item	Stock No.	Description	Quantity								
			22	34	44	46	48	66	68	86	88
1	32 05 008	Pipe, PE2406/PE2708, 4"		X							
	32 05 017	Pipe, PE2406/PE2708, 6"				X				X	
	32 05 018	Pipe, PE2406/PE2708, 8"					X		X		
2	19 22 278	Coupling, Electrofusion, PE3408/PE4710, 2"	1								
	19 22 369	Coupling, Electrofusion, PE3408/PE4710, 3"		1							
	19 22 370	Coupling, Electrofusion, PE3408/PE4710, 4"			1	1	1				
	19 22 371	Coupling, Electrofusion, PE3408/PE4710, 6"						1	1		
	19 22 279	Coupling, Electrofusion, PE3408/PE4710, 8"								1	1
3	19 17 193	Tee, PE2406/PE2708, Butt Fusion, 2"	1								
	19 17 106	Tee, PE2406/PE2708, Butt Fusion, 3"		1							
	19 17 292	Tee, PE2406/PE2708, Butt Fusion, 4"			1	1	1				

UNCONTROLLED IF PRINTED

	19 17 167	Tee, PE2406/PE2708, Butt Fusion, 6"						1	1		
	19 17 107	Tee, PE2406/PE2708, Butt Fusion, 8"								1	1
4	18 66 369	Wire Detector, # 12 AWG, TW, Cu.	X	X	X	X	X	X	X	X	X
5	17 54 842	Connector, Split Bolt, Copper, #16 to #10	1	1	1	1	1	1	1	1	1
6	19 17 066	Reducer, PE2406/PE2708, 3" X 4", Butt Fusion		1							
	19 17 067	Reducer, PE2406/PE2708, 4" X 6", Butt Fusion				1	1				
	19 17 068	Reducer, PE2406/PE2708, 6" X 8", Butt Fusion					1		1	1	
7	32 05 001	Pipe, PE2406/PE2708, 2"	X								
	32 05 016	Pipe, PE2406/PE2708, 3"		X							
	32 05 008	Pipe, PE2406/PE2708, 4"			X	X	X				
	32 05 017	Pipe, PE2406/PE2708, 6"						X	X		
	32 05 018	Pipe, PE2406/PE2708, 8"								X	X
8	49 62 001	Box, Splice, Plastic	1	1	1	1	1	1	1	1	1

X - Number of feet required for specific installation.

Table 4
Inline Tee - High Density PE Pipe

PE3408/PE4710 - High Density PE Pipe - (Black) (G2223 ##)							
Item	Stock No.	Description	Quantity				
			22	44	46	66	
1	32 22 022	Pipe, PE3408/PE4710, 6"			X		
2	19 22 278	Coupling, Electrofusion, PE3408/PE4710, 2"	1				
	19 22 370	Coupling, Electrofusion, PE3408/PE4710, 4"		1	1		
	19 22 371	Coupling, Electrofusion, PE3408/PE4710, 6"					1
3	19 22 237	Tee, PE3408/PE4710, Butt Fusion, 2"	1				
	19 22 238	Tee, PE3408/PE4710, Butt Fusion, 4"		1	1		
	19 22 239	Tee, PE3408/PE4710, Butt Fusion, 6"					1
4	18 66 369	Wire Detector, # 12 AWG, TW, Cu.	X	X	X	X	X
5	17 54 842	Connector, Split Bolt, Copper, #16 to #10	1	1	1	1	1
6	19 22 236	Reducer, PE3408/PE4710, 4" X 6", Butt Fusion			1		
7	32 22 031	Pipe, PE3408/PE4710, 2"	X				
	32 22 021	Pipe, PE3408/PE4710, 4"		X	X		
	32 22 022	Pipe, PE3408/PE4710, 6"					X
8	49 62 001	Box, Splice, Plastic	1	1	1	1	1

X - Number of feet required for specific installation.

A-3. TDW Sidetap (See [Figure 4](#))

A-3.1 Installation

A-3.1.1 Connect new tracer wire to existing tracer wire.

A-3.1.2 Lateral connection shall be electrofusion or butt fusion.

A-3.1.3 Contact the Gas Training Center for proper training and use of the T.D. Williamson side tapping equipment.

A-3.1.4 The Shortstop and Valve combo are available through the MDF.

A-3.1.5 Refer to [TAPS 2.7](#) for installation and tapping procedures.

A-3.2 Approved materials are listed in [Table 5](#) and [Table 6](#).

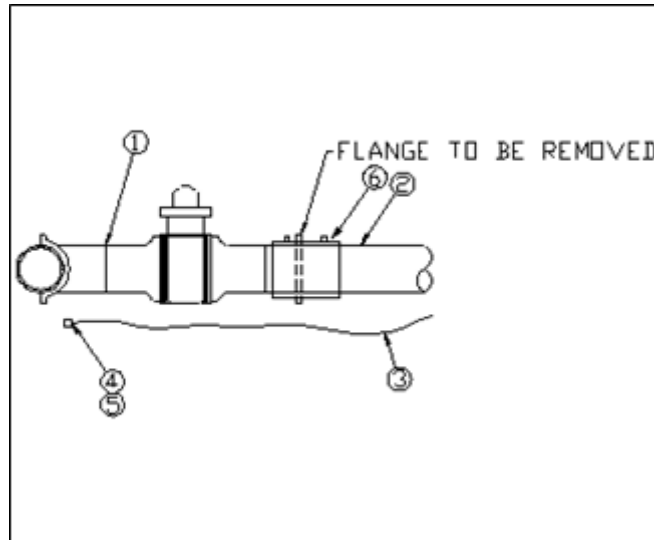

Figure 4
TDW Sidetap

Table 5
TDW Sidetap - Medium Density PE Pipe

PE2406/PE2708 - Medium Density PE Pipe - (Yellow) (G2133 ##)						
Item	Stock No.	Description	Quantity			
			44	64	84	
1	19 67 283	TDW Shortstop and Valve combo, PE3408/PE4710, 4" X 4"	1			
	19 67 282	TDW Shortstop and Valve combo, PE3408/PE4710, 6" X 4"		1		
	19 67 281	TDW Shortstop and Valve combo, PE3408/PE4710, 8" X 4"			1	
2	32 05 008	Pipe, PE2406/PE2708, 4"	X	X	X	
3	18 66 369	Wire Detector, # 12 AWG, TW, Cu.	X	X	X	
4	17 54 842	Connector, Split Bolt, Copper, #16 to #10	1	1	1	
5	49 62 001	Box, Splice, Plastic	1	1	1	
6	19 22 370	Coupling, 4", Electrofusion, PE3408/PE4710	1	1	1	

X - Number of feet required for specific installation.

Table 6
TDW Sidetap - High Density PE Pipe

PE3408/PE4710 - High Density PE Pipe - (Black) (G2233 ##)						
Item	Stock No.	Description	Quantity			
			44	64		
1	19 67 283	TDW Shortstop and Valve combo, PE3408/PE4710, 4" X 4"	1			
	19 67 282	TDW Shortstop and Valve combo, PE3408/PE4710, 6" X 4"		1		
2	32 05 008	Pipe, PE3408/PE4710, 4"	X	X		
3	18 66 369	Wire Detector, # 12 AWG, TW, Cu.	X	X		
4	17 54 842	Connector, Split Bolt, Copper, #16 to #10	1	1		
5	49 62 001	Box, Splice, Plastic	1	1		

6	19 22 370	Coupling, 4", Electrofusion, PE3408/PE4710	1	1
---	-----------	--	---	---

X - Number of feet required for specific installation.

Appendix B - Steel Tees to PE Pipe

Protective sleeve is required on fittings smaller than 2 inch and is optional on fittings 2 inch and larger.

Protective sleeve shall be installed as one piece and not split in half.

B-1. Mueller Tee: Steel Pipe to PE Pipe (See [Figure 5](#))

B-1.1 Installation

B-1.1.1 Contact the local operating center and verify compatibility of tapping and stopping equipment before calling for the installation of this procedure.

B-1.1.2 Ensure that all fittings have an adequate pressure rating for the pipeline on which they are being used.

B-1.1.3 If protective sleeve is installed, it shall be placed over the transition fitting. See Figure 5

B-1.2 Approved materials are listed in [Table 7](#) and [Table 8](#).

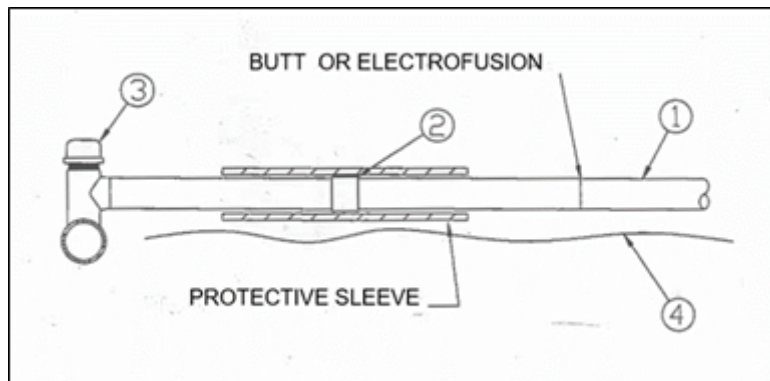

Figure 5
Mueller Tee and Steel transition fitting to PE Pipe

Table 7
Mueller Tee: Steel Pipe to Medium Density PE Pipe

PE2406 (G2141 ##)			
Item	Stock No.	Description	Quantity
			02
1	32 05 001	Pipe, PE2406, 2"	X
2	19 17 129	Transition Fitting, PE2406 to Steel, 2", with Protective Sleeve	1
3	19 33 286	Tee, Steel, Service Tee, Mueller, 2"	1

UNCONTROLLED IF PRINTED

4	18 66 369	Wire Detector, # 12 AWG, TW, Cu.	X
---	-----------	----------------------------------	---

X - Number of feet required for specific installation.

Table 8
Mueller Tee: Steel Pipe to High Density PE Pipe

PE3408 (G2241 ##)			
Item	Stock No.	Description	Quantity
			02
1	32 22 020	Pipe, PE3408, 2"	X
2	19 22 106	Transition Fitting, PE3408 to Steel, 2", with Protective Sleeve	1
3	19 33 286	Tee, Steel, Service Tee, Mueller, 2"	1
4	18 66 369	Wire Detector, # 12 AWG, TW, Cu.	X

X - Number of feet required for specific installation.

B-2. Mueller Curb Valve Tee: Steel Pipe to PE Pipe (See [Figure 6](#))

B-2.1 Installation

B-2.1.1 The Mueller Valve Tee, 19 33 562, may be substituted for the curb valve tee.

B-2.1.2 Contact the local operating center and verify compatibility of tapping and stopping equipment before calling for the installation of this standard.

B-2.1.3 In steel applications, ensure that all fittings have an adequate pressure rating for the pipeline on which it is being used.

B-2.1.4 If protective sleeve is installed it shall be placed over the transition fitting. See Figure 6.

B-2.2 Approved materials are listed in [Table 9](#) and [Table 10](#).

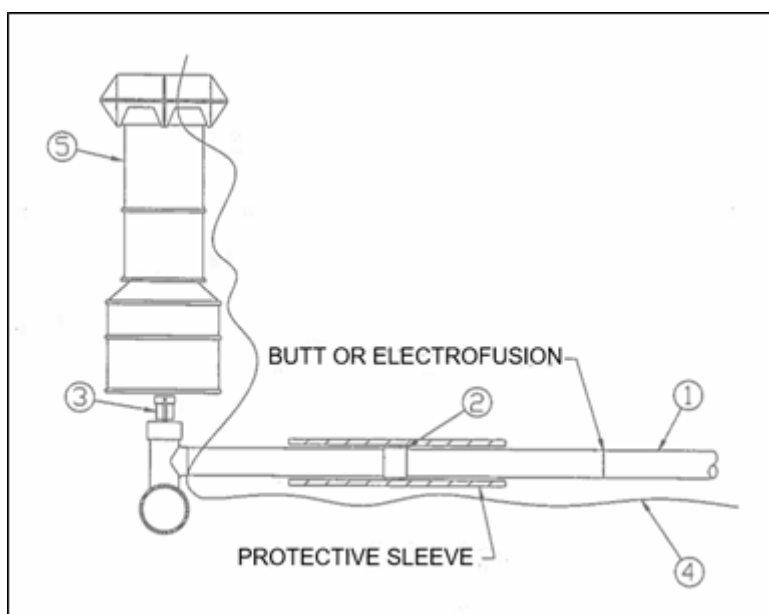

Figure 6
Mueller Curb Valve Tee and Steel Transition fitting to PE Pipe

Table 9
Mueller Valve Tee: Steel Pipe to Medium Density PE Pipe

UNCONTROLLED IF PRINTED

PE2406 (G 2151 ##)			
Item	Stock No.	Description	Quantity
			02
1	32 05 001	Pipe, PE2406, 2"	X
2	19 17 129	Transition Fitting, PE2406 to Steel, 2", with Protective Sleeve	1
3	19 12 230	Tee, Steel, Curb Valve, 2", 1440 psig, with 2" x 2" Square Head	1
4	18 66 369	Wire Detector, # 12 AWG, TW, Cu.	X
5	19 72 129	Box, Curb, For 2" Curb Valve Tees	1

X - Number of feet required for specific installation.

Table 10
Mueller Valve Tee: Steel Pipe to High Density PE Pipe

PE3408 (G 2251 ##)			
Item	Stock No.	Description	Quantity
			02
1	32 22 020	Pipe, PE3408, 2"	X
2	19 22 106	Transition Fitting, PE3408 to Steel, 2", with Protective Sleeve	1
3	19 12 230	Tee, Steel, Curb Valve, 2", 1440 psig, with 2" x 2" Square Head	1
4	18 66 369	Wire Detector, # 12 AWG, TW, Cu.	X
5	19 72 129	Box, Curb, For 2" Curb Valve Tees	1

X - Number of feet required for specific installation.

B-3. Mueller Bottom Out Tee:Steel Pipe to PE Pipe (See [Figure 7](#))

B-3.1 Installation

- B-3.1.1 Contact the local operating center and verify compatibility of tapping and stopping equipment before calling for the installation of this standard.
- B-3.1.2 An elbow may be used in place of the inline tee and cap
- B-3.1.3 If protective sleeve is installed it shall be placed over the transition fitting. See Figure 7.
- B-3.1.4 In the event that depth of the excavation is a concern, a T.D. Williamson M-Stoppp fitting may be used in place of the Mueller bottom out tee.
- B-3.1.5 See [TAPS 2.7](#), for minimum cutting/welding distances to prevent damage to the stopper.
- B-3.2 Approved materials are listed in [Table 11](#) and [Table 12](#).

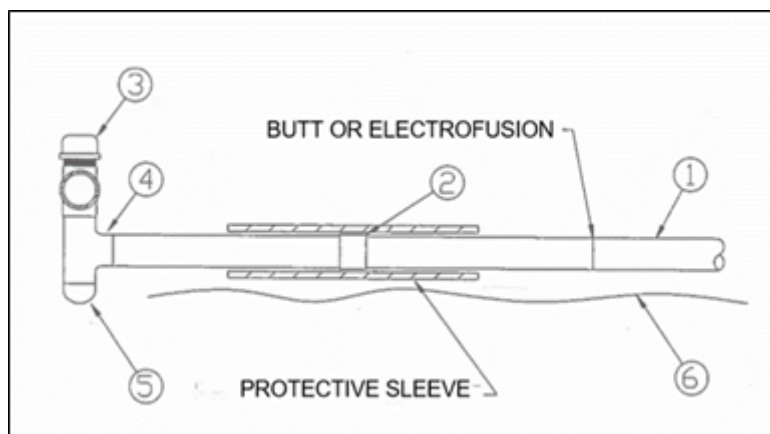

UNCONTROLLED IF PRINTED

Figure 7
Mueller Bottom Out Tee and Steel Transition Fitting to PE Pipe

Table 11
Mueller Bottom Out Tee: Steel Pipe to Medium Density PE Pipe

PE2406 (G2161 ##)						
Item	Stock No.	Description	Quantity			
			22	44	66	88
1	32 05 001	Pipe, PE2406, 2"	X			
	32 05 008	Pipe, PE2406, 4"		X		
	32 05 017	Pipe, PE2406, 6"			X	
	32 05 018	Pipe, PE2406, 8"				X
2	19 17 129	Sleeve, PE2406 to Steel, Transition, 2"	1			
	19 17 131	Sleeve, PE2406 to Steel, Transition, 4"		1		
	19 17 132	Sleeve, PE2406 to Steel, Transition, 6"			1	
	19 17 336	Sleeve, PE2406 to Steel, Transition, 8"				1
3	19 33 045	Line Stopper, Weld, Modified, 250 lb., 2"	1			
	19 12 470	Line Stopper, Weld, Modified, 275 lb., 4"		1		
	19 33 023	Line Stopper, Weld, Modified, 275 lb., 6"			1	
	19 33 034	Line Stopper, Weld, Modified, 275 lb., 8"				1
4	19 12 256	Tee, Weld, Inline, 2"	1			
	19 33 644	Tee, Weld, Inline, 4"		1		
	19 33 657	Tee, Weld, Inline, 6"			1	
	19 12 443	Tee, Weld, Inline, 8"				1
5	19 15 155	Cap, Steel, Weld, 2"	1			
	19 33 658	Cap, Steel, Weld, 4"		1		
	19 15 158	Cap, Steel, Weld, 6"			1	
	19 15 159	Cap, Steel, Weld, 8"				1
6	18 66 369	Wire Detector, # 12 AWG, TW, Cu.	X	X	X	X

Table 12
Mueller Bottom Out Tee: Steel Pipe to High Density PE Pipe

PE3408 (G2261 ##)						
Item	Stock No.	Description	Quantity			
			22	44	66	
1	32 22 020	Pipe, PE3408, 2"	X			
	32 22 021	Pipe, PE3408, 4"		X		
	32 22 022	Pipe, PE3408, 6"			X	
2	19 22 106	Sleeve, PE3408 to Steel, Transition, 2"	1			
	19 22 109	Sleeve, PE3408 to Steel, Transition, 4"		1		
	19 22 111	Sleeve, PE3408 to Steel, Transition, 6"			1	
3	19 33 045	Line Stopper, Weld, Modified, 250 lb., 2"	1			
	19 12 470	Line Stopper, Weld, Modified, 275 lb., 4"		1		

UNCONTROLLED IF PRINTED

	19 33 023	Line Stopper, Weld, Modified, 275 lb., 6"			1
4	19 12 256	Tee, Weld, Inline, 2"	1		
	19 33 644	Tee, Weld, Inline, 4"		1	
	19 33 657	Tee, Weld, Inline, 6"			1
5	19 15 155	Cap, Steel, Weld, 2"	1		
	19 33 658	Cap, Steel, Weld, 4"		1	
	19 15 158	Cap, Steel, Weld, 6"			1
6	18 66 369	Wire Detector, # 12 AWG, TW, Cu.	X	X	X

B-4. TDW Tee: Steel Pipe to PE Pipe (See [Figure 8](#))

B-4.1 Installation

B-4.1.1 Contact the local operating center and verify compatibility of tapping and stopping equipment before calling for the installation of this standard.

B-4.1.2 If protective sleeve is installed it shall be placed over the transition fitting.

B-4.1.3 If the depth of the fitting is a concern or a bottom outlet is needed, a TDW spherical tee may be used in place of the 3-way-tee.

B-4.2 Approved materials are listed in [Table 13](#) and [Table 14](#).

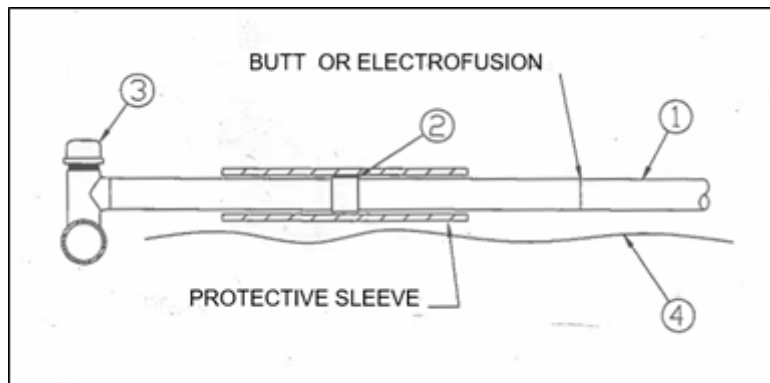

Figure 8
TDW Tee with Steel Transition fitting to PE Pipe

Table 13
TDW Tee with Steel Pipe to Medium Density PE Pipe

PE2406 (G2171 ##)						
Item	Stock No.	Description	Quantity			
			02	04	06	08
1	32 05 001	Pipe, PE2406, 2"	X			
	32 05 008	Pipe, PE2406, 4"		X		
	32 05 017	Pipe, PE2406, 6"			X	
	32 05 018	Pipe, PE2406, 8"				X
2	19 17 129	Sleeve, PE2406 to Steel, Transition, 2"	1			
	19 17 131	Sleeve, PE2406 to Steel, Transition, 4"		1		
	19 17 132	Sleeve, PE2406 to Steel, Transition, 6"			1	
	19 17 336	Sleeve, PE2406 to Steel, Transition, 8"				1
3	19 08 417	3-Way-Tee, Class 150, TDW, 2"	1			

UNCONTROLLED IF PRINTED

	19 12 197	3-Way-Tee, Class 150, TDW, 4"		1		
	19 23 616	3-Way-Tee, Class 150, TDW, 6"			1	
	19 23 619	3-Way-Tee, Class 150, TDW, 8"				1
4	18 66 369	Wire Detector, # 12 AWG, TW, Cu.	X	X	X	X

Table 14
TDW Tee: Steel Pipe to High Density PE Pipe

PE3408 (G2271 ##)						
Item	Stock No.	Description	Quantity			
			02	04	06	
1	32 22 020	Pipe, PE3408, 2"	X			
	32 22 021	Pipe, PE3408, 4"		X		
	32 22 022	Pipe, PE3408, 6"			X	
2	19 22 106	Sleeve, PE3408 to Steel, Transition, 2"	1			
	19 22 109	Sleeve, PE3408 to Steel, Transition, 4"		1		
	19 22 111	Sleeve, PE3408 to Steel, Transition, 6"			1	
3	19 08 417	3-Way-Tee, Class 150, TDW, 2"	1			
	19 12 197	3-Way-Tee, Class 150, TDW, 4"		1		
	19 23 616	3-Way-Tee, Class 150, TDW, 6"			1	
4	18 66 369	Wire Detector, # 12 AWG, TW, Cu.	X	X	X	

Appendix C - Steel to Steel Tees

C-1. Mueller Tee (See [Figure 9](#))

C-1.1 Installation

C-1.1.1 Contact the local operating center and verify compatibility of tapping and stopping equipment before calling for the installation of this standard.

C-1.1.2 Ensure that all fittings have an adequate pressure rating for the pipeline on which they are being used.

C-1.2 Approved materials are listed in [Table 15](#).

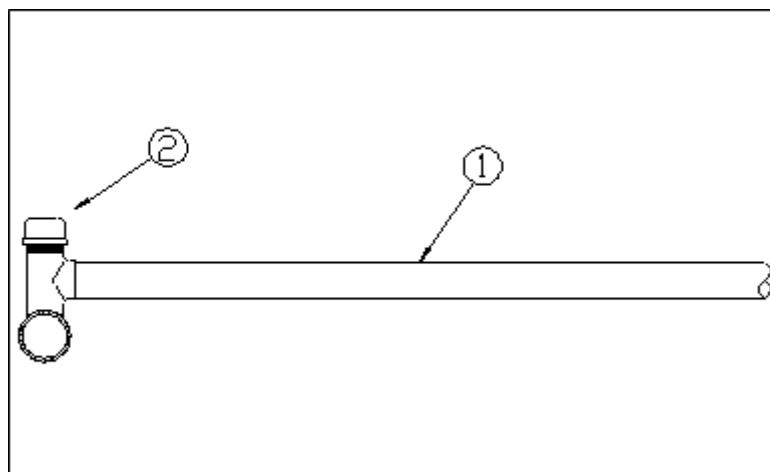

UNCONTROLLED IF PRINTED

Figure 9
Mueller Tee

Table 15
Mueller Tee

(G2311 ##)			
Item	Stock No.	Description	Quantity
			02
1	32 23 319	Pipe, Steel, 2"	X
2	19 33 286	Tee, Steel, Service Tee, Mueller, 2"	1

C-2. Mueller Curb Valve Tee (See [Figure 10](#))

C-2.1 Installation

C-2.1.1 Contact the local operating center and verify compatibility of tapping and stopping equipment before calling for the installation of this standard.

C-2.1.2 Ensure that all fittings have an adequate pressure rating for the pipeline on which it is being used.

C-2.1.3 The Mueller Valve Tee, 19 33 562, may be substituted for the curb valve tee.

C-2.2 Approved materials are listed in [Table 16](#).

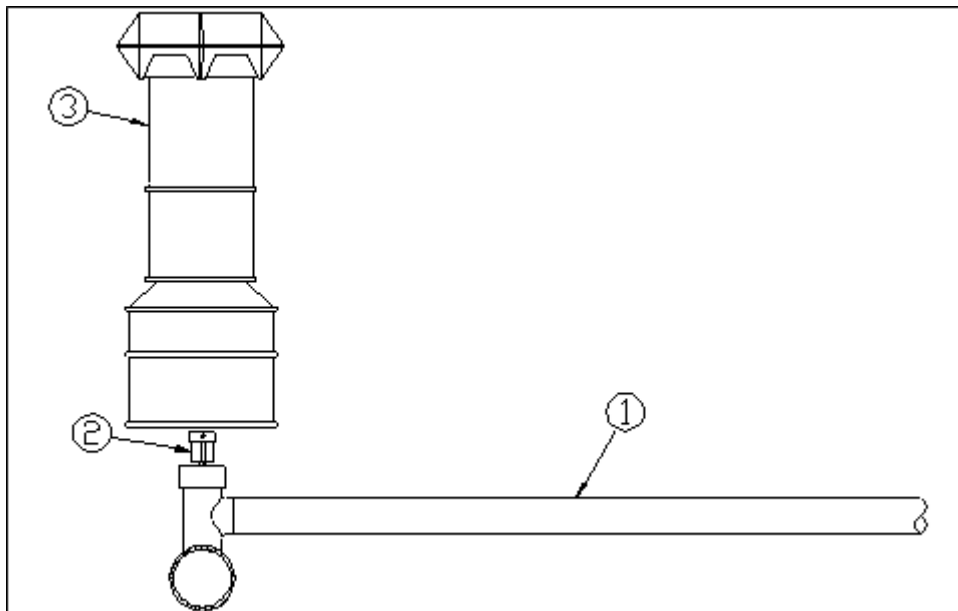

Figure 10
Mueller Valve Tee

Table 16
Mueller Valve Tee

(G2321 ##)			
Item	Stock No.	Description	Quantity

			02
1	32 23 319	Pipe, Steel, 2"	X
2	19 12 230	Tee, Steel, Curb Valve, 2", 1440 psig, with 2" x 2" Square Head	1
3	19 72 129	Box, Curb, For 2" Valve Tees	1

C-3. Mueller Bottom Out Tee (See [Figure 11](#))

C-3.1 Installation

C-3.1.1 Contact the local operating center and verify compatibility of tapping and stopping equipment before calling for the installation of this standard.

C-3.1.2 Ensure that all fittings have an adequate pressure rating for the pipeline on which they are being used.

C-3.1.3 An elbow may be used in place of the inline tee and cap.

C-3.1.4 In the event that depth of the excavation is a concern, a T.D. Williamson M-Stopp fitting may be used in place of the Mueller bottom out tee.

C-3.1.5 See [TAPS 2.4](#) for minimum cutting/welding distances to prevent damage to the stopper.

C-3.2 Approved materials are listed in [Table 17](#).

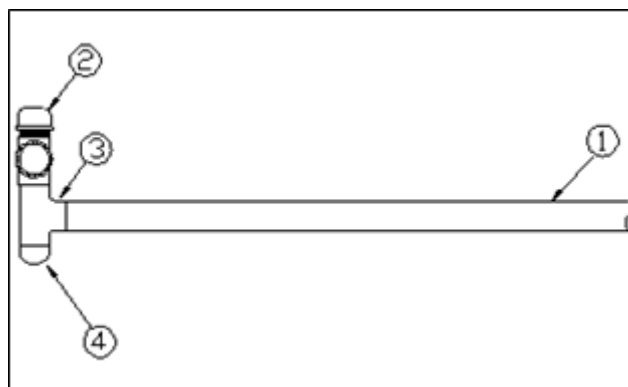

Figure 11
Mueller Bottom Out Tee

Table 17
Mueller Bottom Out Tee

(G2331 ##)						
Item	Stock No.	Description	Quantity			
			22	44	66	88
1	32 23 319	Pipe, Steel, 2"	X			
	32 23 330	Pipe, Steel, 4"		X		
	32 23 340	Pipe, Steel, 6"			X	
	32 23 348	Pipe, Steel, 8"				X
2	19 33 045	Line Stopper, Weld, Modified, 250 lb., 2"	1			
	19 12 470	Line Stopper, Weld, Modified, 275 lb., 4"		1		
	19 33 023	Line Stopper, Weld, Modified, 275 lb., 6"			1	

	19 33 034	Line Stopper, Weld, Modified, 275 lb., 8"				1
3	19 12 256	Tee, Weld, Inline, 2"	1			
	19 33 644	Tee, Weld, Inline, 4"		1		
	19 33 657	Tee, Weld, Inline, 6"			1	
	19 12 443	Tee, Weld, Inline, 8"				1
4	19 15 155	Cap, Steel, Weld, 2"	1			
	19 33 658	Cap, Steel, Weld, 4"		1		
	19 15 158	Cap, Steel, Weld, 6"			1	
	19 15 159	Cap, Steel, Weld, 8"				1

C-4. TDW Tee (See [Figure 12](#))

C-4.1 Installation

C-4.1.1 Contact the local operating center and verify compatibility of tapping and stopping equipment before calling for the installation of this standard.

C-4.1.2 Ensure that all fittings have an adequate pressure rating for the pipeline on which they are being used.

C-4.1.3 If the depth of the fitting is a concern or a bottom outlet is needed, a TDW spherical tee may be used in place of the 3-way-tee.

C-4.2 Approved materials are listed in [Table 18](#).

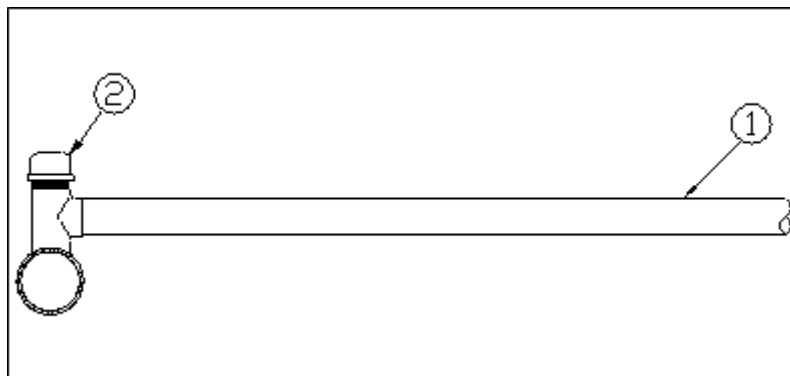

Figure 12
TDW Tee

Table 18
TDW Tee

(G2341 ##)						
Item	Stock No.	Description	Quantity			
			02	04	06	08
1	32 23 319	Pipe, Steel, 2"	X			
	32 23 330	Pipe, Steel, 4"		X		
	32 23 340	Pipe, Steel, 6"			X	
	32 23 348	Pipe, Steel, 8"				X
2	19 08 417	3-Way-Tee, Class 150, TDW, 2"	1			
	19 12 197	3-Way-Tee, Class 150, TDW, 4"		1		

UNCONTROLLED IF PRINTED

19 23 616	3-Way-Tee, Class 150, TDW, 6"			1	
19 23 619	3-Way-Tee, Class 150, TDW, 8"				1

MAIN INSTALLATION

October 1, 2021

MAIN 3.2 End of Main Extension

1.0 Purpose

This procedure provides installation and material requirements for end of main extensions.

2.0 Scope

This document addresses the following:

[3.0 Target Audience](#)[4.0 Main Extension - PE Pipe](#)[5.0 Main Extension - Steel to PE Pipe](#)[6.0 Main Extension - Steel to Steel Pipe](#)

Appendices

[Appendix A - Main Extension - PE Pipe](#)[Appendix B - Main Extension - Steel to PE Pipe](#)[Appendix C - Main Extension - Steel to Steel Pipe](#)**3.0 Target Audience**

- Gas Engineering
- Gas Distribution Design Specialist
- Field Engineering Representatives
- Gas Field Personnel
- Gas Supervisors
- Gas Construction Services Personnel

4.0 Main Extension - PE Pipe

- 4.1 PE Pipe (See [Appendix A-1](#))
- 4.2 PE Pipe, Increasing Size (See [Appendix A-2](#))
- 4.3 PE Pipe, Decreasing Size (See [Appendix A-3](#))

5.0 Main Extension - Steel to PE Pipe

- 5.1 Mueller Stopper - Steel to PE Pipe (See [Appendix B-1](#))
- 5.2 Mueller Stopper - Steel to PE Pipe Increasing Size (See [Appendix B-2](#))
- 5.3 Mueller Stopper - Steel to PE Pipe Decreasing Size (See [Appendix B-3](#))
- 5.4 TDW Stopper - Steel to PE Pipe (See [Appendix B-4](#))
- 5.5 TDW Stopper - Steel to PE Pipe Increasing Size (See [Appendix B-5](#))
- 5.6 TDW Stopper - Steel to PE Pipe Decreasing Size (See [Appendix B-6](#))

6.0 Main Extension - Steel to Steel Pipe

- 6.1 Mueller Stopper (See [Appendix C-1](#))
- 6.2 Mueller Stopper - Steel to Steel Pipe Increasing Size (See [Appendix C-2](#))
- 6.3 Mueller Stopper - Steel to Steel Pipe Decreasing Size (See [Appendix C-3](#))

UNCONTROLLED IF PRINTED

- 6.4 TDW Stopper (See [Appendix C-4](#))
- 6.5 TDW Stopper - Steel to Steel Pipe Increasing Size (See [Appendix C-5](#))
- 6.6 TDW Stopper - Steel to Steel Pipe Decreasing Size (See [Appendix C-6](#))

End of Instructions.

Operator Qualification (OQ) Required?

YES

- 0641: Visually Inspect Pipe and Components Prior to Installation
- 0681: Joining of Plastic Pipe - Stab Fittings
- 0751: Joining of Plastic Pipe - Butt Heat Fusion: Manual
- 0761: Joining of Plastic Pipe - Butt Heat Fusion: Hydraulic Machine
- 0781: Joining of Plastic Pipe - Electrofusion
- 0801: Welding

Appendices

- [Appendix A - Main Extension - PE Pipe](#)
- [Appendix B - Main Extension - Steel to PE Pipe](#)
- [Appendix C - Main Extension - Steel to Steel Pipe](#)

Attachments

NONE.

Compliance Requirements

NONE.

Reference Documents

- [TAPS 2.4 Tapping and Stopping: Mueller Tapping and Stopping Procedure](#)
- [TAPS 2.5 Tapping and Stopping: T.D. Williamson Tapping and Stopping Procedure](#)

Document Rescission

MAIN 3.2 Main Installation: End of Main Extension, April 1, 2021.

Revision Notes

Location of Changes	Summary of Changes
Appendix A – A-3 PE Pipe Decreasing Size – Table 6	Updated Stock Code for 4" x 6" Reducer PE 3408/PE4710
Appendix C – C-2 Mueller Stopper - Pipe Increasing Size – Table 20	Updated Stock Codes for: 2" x 4" and 4" x 6" Weld Steel Reducer

UNCONTROLLED IF PRINTED

Appendix C – C-3 Mueller Stopper - Pipe Decreasing Size – Table 21	Updated Stock Codes for: 3" x 2" and 4" x 2" Weld Steel Reducer
Appendix C – C-5 TDW Stopper – Pipe Increasing Size – Ta- ble 23	Updated Stock Codes for: 2" x 4" and 4" x 6" Weld Steel Reducer
Appendix C – C-6 TDW Stopper – Pipe Decreasing Size – Table 24	Updated Stock Codes for: 3" x 2", 4" x 2" and 6" x 4" Weld Steel Reduc- er.

Appendix A - Main Extension - PE Pipe

A-1. PE Pipe (See [Figure 1](#))

A-1.1 Installation

A-1.1.1 Connect new tracer wire to existing tracer wire.

A-1.1.2 End of main connection shall be electrofusion or butt fusion.

A-1.2 Approved materials are listed in [Table 1](#) and [Table 2](#).

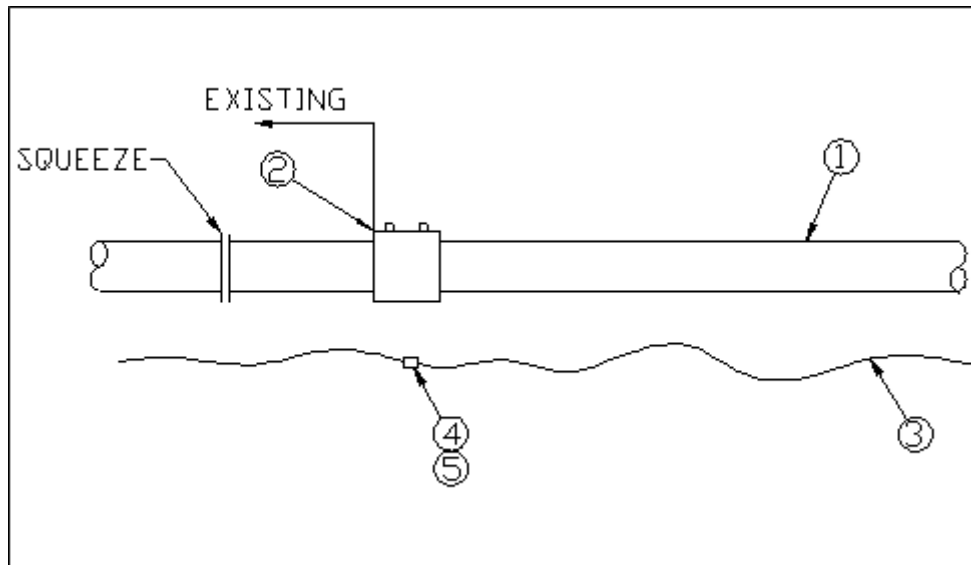

Figure 1

Main Extension - PE Pipe

Table 1

Main Extension (Medium Density PE Pipe)

PE2406/PE2708 - Medium Density PE Pipe - (Yellow) (G2513 ##)						
Item	Stock No.	Description	Quantity			
			22	44	66	88
1	32 05 001	Pipe, PE2406/PE2708, 2"	X			

UNCONTROLLED IF PRINTED

	32 05 008	Pipe, PE2406/PE2708, 4"		X		
	32 05 017	Pipe, PE2406/PE2708, 6"			X	
	32 05 018	Pipe, PE2406/PE2708, 8"				X
2	19 22 278	Coupling, Electrofusion, PE3408/PE4710, 2"	1			X
	19 22 370	Coupling, Electrofusion, PE3408/PE4710, 4"		1		
	19 22 371	Coupling, Electrofusion, PE3408/PE4710, 6"			1	
	19 22 279	Coupling, Electrofusion, PE3408/PE4710, 8"				1
3	18 66 369	Wire Detector, # 12 AWG, TW, Cu.	X	X	X	X
4	17 54 842	Connector, Split Bolt, Copper, #16 to #10	1	1	1	1
5	49 62 001	Box, Splice, Plastic	1	1	1	1

X - Number of feet required for specific installation

Table 2

Main Extension (High Density PE Pipe)

PE3408/PE4710 - High Density PE Pipe - (Black) (G2613 ##)						
Item	Stock No.	Description	Quantity			
			22	44	66	
1	32 22 020	Pipe, PE3408/PE4710, 2"	X			
	32 22 021	Pipe, PE3408/PE4710, 4"		X		
	32 22 022	Pipe, PE3408/PE4710, 6"			X	
2	19 22 278	Coupling, Electrofusion, PE3408/PE4710, 2"	1			
	19 22 370	Coupling, Electrofusion, PE3408/PE4710, 4"		1		
	19 22 371	Coupling, Electrofusion, PE3408/PE4710, 6"			1	
3	18 66 369	Wire Detector, # 12 AWG, TW, Cu.	X	X	X	
4	17 54 842	Connector, Split Bolt, Copper, #16 to #10	1	1	1	
5	49 62 001	Box, Splice, Plastic	1	1	1	

X - Number of feet required for specific installation

A-2. PE Pipe, Increasing Size (See [Figure 2](#))

A-2.1 Installation

A-2.1.1 Connect new tracer wire to existing tracer wire.

A-2.1.2 End of main connection shall be electrofusion or butt fusion.

A-2.2 Approved materials are listed in [Table 3](#) and [Table 4](#).

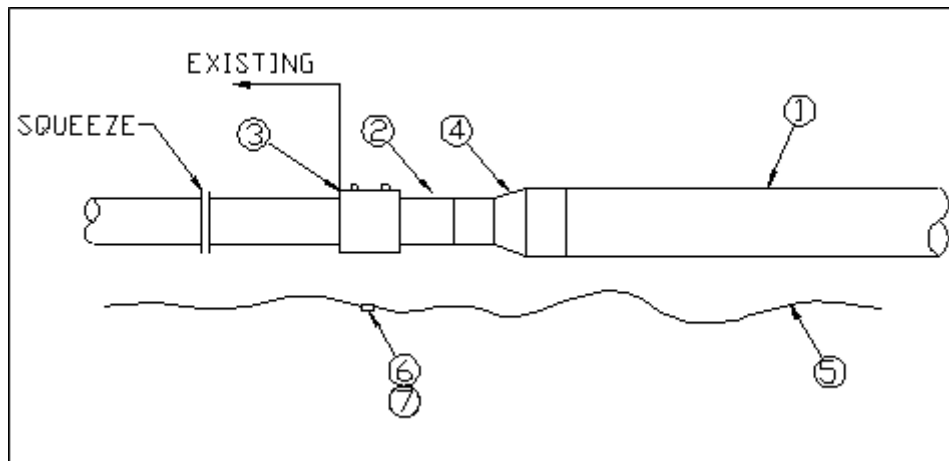

Figure 2
Main Extension, PE Pipe, Increasing size

Table 3
Increasing Main Size (Medium Density PE Pipe)

PE2406/PE2708 - Medium Density PE Pipe - (Yellow) (G2523 ##)							
Item	Stock No.	Description	Quantity				
			12	24	34	46	68
1	32 05 001	Pipe, PE2406/PE2708, 2"	X				
	32 05 008	Pipe, PE2406/PE2708, 4"		X	X		
	32 05 017	Pipe, PE2406/PE2708, 6"				X	
	32 05 018	Pipe, PE2406/PE2708, 8"					X
2	32 22 023	Pipe, PE2406/PE2708, 1 1/4"	X				
	32 05 001	Pipe, PE2406/PE2708, 2"		X			
	32 05 016	Pipe, PE2406/PE2708, 3"			X		
	32 05 008	Pipe, PE2406/PE2708, 4"				X	
	32 05 017	Pipe, PE2406/PE2708, 6"					X
3	19 22 368	Coupling, Electrofusion, PE3408/PE4710, 1 1/4"	1				
	19 22 278	Coupling, Electrofusion, PE3408/PE4710, 2"		1			
	19 22 369	Coupling, Electrofusion, PE3408/PE4710, 3"			1		
	19 22 370	Coupling, Electrofusion, PE3408/PE4710, 4"				1	
	19 22 371	Coupling, Electrofusion, PE3408/PE4710, 6"					1
4	19 17 324	Reducer, PE 2406/PE2708, Butt Fusion, 1 1/4" X 2"	1				
	19 17 064	Reducer, PE 2406/PE2708, Butt Fusion, 2" X 4"		1			
	19 17 066	Reducer, PE 2406/PE2708, Butt Fusion, 3" X 4"			1		
	19 17 067	Reducer, PE 2406/PE2708, Butt Fusion, 4" X 6"				1	
	19 17 068	Reducer, PE 2406/PE2708, Butt Fusion, 6" X 8"					1
5	18 66 369	Wire Detector, # 12 AWG, TW, Cu.	X	X	X	X	X
6	17 54 842	Connector, Split Bolt, Copper, #16 to #10	1	1	1	1	1
7	49 62 001	Box, Splice, Plastic	1	1	1	1	1

X - Number of feet required for specific installation

UNCONTROLLED IF PRINTED

Table 4
Increasing Main Size (High Density PE Pipe)

PE3408/PE4710 - High Density PE Pipe - (Black) (G2623 ##)				
Item	Stock No.	Description	Quantity	
			24	46
1	32 22 021	Pipe, PE3408/PE4710, 4"	X	
	32 22 022	Pipe, PE3408/PE4710, 6"		X
2	32 22 020	Pipe, PE3408/PE4710, 2"	X	
	32 22 021	Pipe, PE3408/PE4710, 4"		X
3	19 22 278	Coupling, Electrofusion, PE3408/PE4710, 2"	1	
	19 22 370	Coupling, Electrofusion, PE3408/PE4710, 4"		1
4	19 22 235	Reducer, PE3408/PE4710, Butt Fusion, 2" X 4"	1	
	19 22 236	Reducer, PE3408/PE4710, Butt Fusion, 4" X 6"		1
5	18 66 369	Wire Detector, # 12 AWG, TW, Cu.	X	X
6	17 54 842	Connector, Split Bolt, Copper, #16 to #10	1	1
7	49 62 001	Box, Splice, Plastic	1	1

X - Number of feet required for specific installation

A-3. PE Pipe, Decreasing Size (See [Figure 3](#))

A-3.1 Installation

A-3.1.1 Connect new tracer wire to existing tracer wire.

A-3.1.2 End of main connection shall be electrofusion or butt fusion.

A-3.2 Approved materials are listed in [Table 5](#) and [Table 6](#).

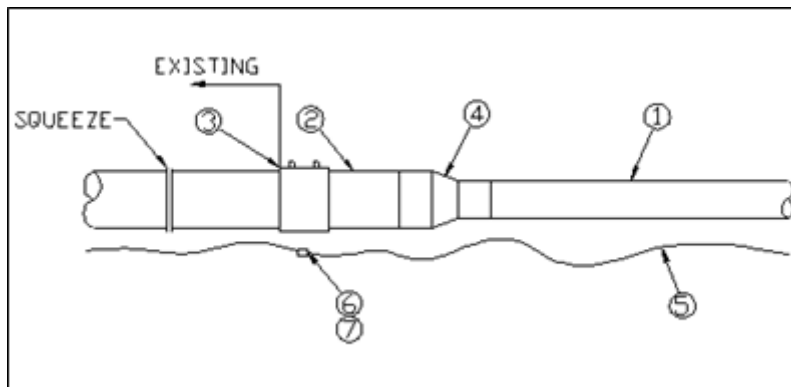

Figure 3

Main Extension, PE Pipe, Decreasing size

Table 5
Decreasing Main Size (Medium Density PE Pipe)

PE2406/PE2708 - Medium Density PE Pipe - (Yellow) (G2533 ##)
--

Item	Stock No.	Description	Quantity			
			32	42	64	86
1	32 05 001	Pipe, PE2406/PE2708, 2"	X	X		
	32 05 008	Pipe, PE2406/PE2708, 4"			X	
	32 05 017	Pipe, PE2406/PE2708, 6"				X
2	32 05 016	Pipe, PE2406/PE2708, 3"	X			
	32 05 008	Pipe, PE2406/PE2708, 4"		X		
	32 05 017	Pipe, PE2406/PE2708, 6"			X	
	32 05 018	Pipe, PE2406/PE2708, 8"				X
3	19 22 369	Coupling, Electrofusion, PE3408/PE4710, 3"	1			
	19 22 370	Coupling, Electrofusion, PE3408/PE4710, 4"		1		
	19 22 371	Coupling, Electrofusion, PE3408/PE4710, 6"			1	
	19 22 279	Coupling, Electrofusion, PE3408/PE4710, 8"				1
4	19 17 062	Reducer, PE2406/PE2708, Butt Fusion, 2" X 3"	1			
	19 17 064	Reducer, PE2406/PE2708, Butt Fusion, 2" X 4"		1		
	19 17 067	Reducer, PE2406/PE2708, Butt Fusion, 4" X 6"			1	
	19 17 068	Reducer, PE2406/PE2708, Butt Fusion, 6" X 8"				1
5	18 66 369	Wire Detector, # 12 AWG, TW, Cu.	X	X	X	X
6	17 54 842	Connector, Split Bolt, Copper, #16 to #10	1	1	1	1
7	49 62 001	Box, Splice, Plastic	1	1	1	1

X - Number of feet required for specific installation

Table 6

Decreasing Main Size (High Density PE Pipe)

PE3408/PE4710 - High Density PE Pipe - (Black) (G2633 ##)						
Item	Stock No.	Description	Quantity			
			42	64		
1	32 22 020	Pipe, PE3408/PE4710, 2"	X			
	32 22 021	Pipe, PE3408/PE4710, 4"			X	
2	32 22 021	Pipe, PE3408/PE4710, 4"	X			
	32 22 022	Pipe, PE3408/PE4710, 6"			X	
3	19 22 370	Coupling, Electrofusion, PE3408/PE4710, 4"	1			
	19 22 371	Coupling, Electrofusion, PE3408/PE4710, 6"			1	
4	19 22 235	Reducer, PE3408/PE4710, Butt Fusion, 2" X 4"	1			
	19 22 236	Reducer, PE3408/PE4710, Butt Fusion, 4" X 6"			1	
5	18 66 369	Wire Detector, # 12 AWG, TW, Cu.	X	X		
6	17 54 842	Connector, Split Bolt, Copper, #16 to #10	1	1		
7	49 62 001	Box, Splice, Plastic	1	1		

X - Number of feet required for specific installation

Appendix B - Main Extension - Steel to PE Pipe

NOTES

Protective sleeve is required on fittings smaller than 2 inch and is optional on fittings 2 inch and larger.

Protective sleeve shall be installed as one piece and not split in half.

B-1. Mueller Stopper: Steel to PE Pipe (See [Figure 4](#))

B-1.1 Installation

B-1.1.1 Contact the local operating center and verify compatibility of tapping and stopping equipment before calling for the installation of this standard.

B-1.1.2 The final tie-in weld shall be butt or socket weld. Socket weld is approved for 2 inch and smaller pipe.

B-1.1.3 If protective sleeve is installed, it shall be placed over the transition fitting. See Figure 4.

B-1.1.4 See [TAPS 2.4](#) for minimum cutting/welding distances to prevent damage to stopper.

B-1.2 Approved materials are listed in [Table 7](#) and [Table 8](#).

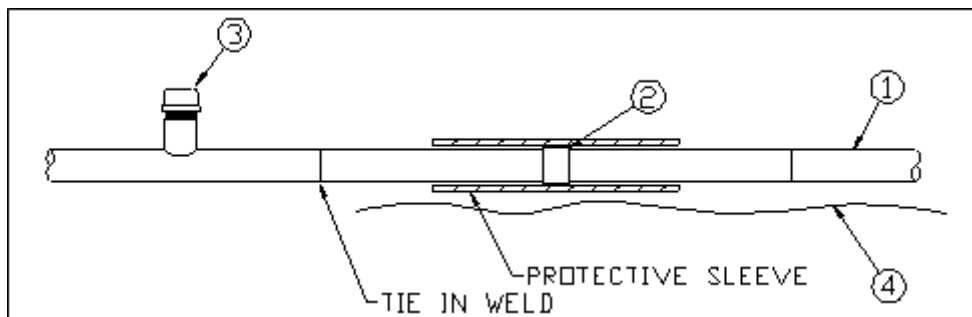

Figure 4

Muller Stopper and Steel Transition Fitting to PE Pipe

Table 7

Steel to Medium Density PE Pipe using a Mueller Stopper

PE2406 (G2541 ##)				
Item	Stock No.	Description	Quantity	
			22	44
1	32 05 001	Pipe, PE2406, 2"	X	
	32 05 008	Pipe, PE2406, 4"		X
2	19 17 129	Transition Fitting, PE2406 to Steel, 2", with Protective Sleeve	1	
	19 17 131	Transition Fitting, PE2406 to Steel, 2", with Protective Sleeve"		1
3	19 12 477	Fitting, Stopper, 2", Steel, Weld, Class 150, Mueller	1	
	19 23 148	Fitting, Stopper, 4", Steel, Weld, Class 150, Mueller		1
4	18 66 369	Wire Detector, # 12 AWG, TW, Cu.	X	X

X - Number of feet required for specific installation

Table 8
Steel to High Density PE Pipe using a Mueller Stopper

PE3408 (G2641 ##)				
Item	Stock No.	Description	Quantity	
			22	44
1	32 22 020	Pipe, PE3408, 2"	X	
	32 22 021	Pipe, PE3408, 4"		X
2	19 22 106	Transition Fitting, PE3408 to Steel, 2", with Protective Sleeve"	1	
	19 22 109	Transition Fitting, PE3408 to Steel, 4", with Protective Sleeve		1
3	19 12 477	Fitting, Stopper, 2", Steel, Weld, Class 150, Mueller	1	
	19 23 148	Fitting, Stopper, 4", Steel, Weld, Class 150, Mueller		1
4	18 66 369	Wire Detector, # 12 AWG, TW, Cu.	X	X

X - Number of feet required for specific installation

B-2. Mueller Stopper - Steel to PE Pipe Increasing Size (See [Figure 5](#))

B-2.1 Installation

- B-2.1.1 Contact the local operating center and verify compatibility of tapping and stopping equipment before calling for the installation of this standard.
- B-2.1.2 The final tie-in weld shall be butt or socket weld. Socket weld is approved for 2 inch and smaller pipe.
- B-2.1.3 If protective sleeve is install it shall be placed over the transition fitting. See Figure 5.
- B-2.1.4 See [TAPS 2.4](#) for minimum cutting/welding distances to prevent damage to stopper.

B-2.2 Approved materials are listed in [Table 9](#) and [Table 10](#).

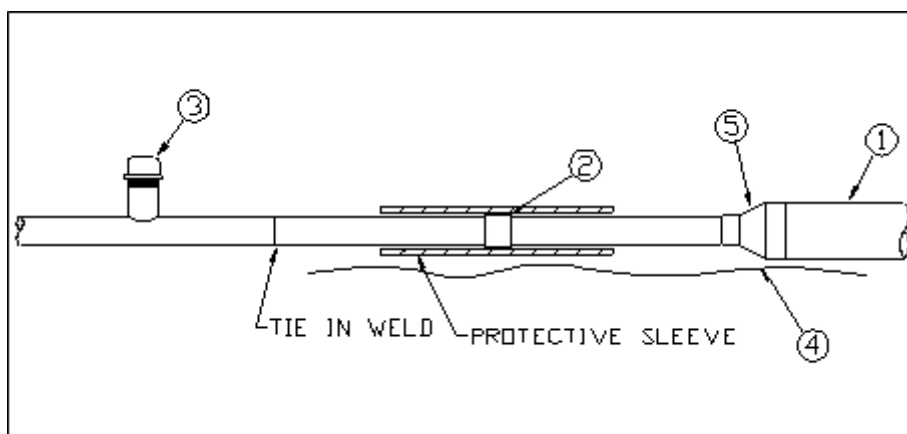

Figure 5

Mueller Stopper and Steel Transition Fitting to PE Pipe - Increasing Size

Table 9
Steel to Medium Density PE Pipe Increasing Size

PE2406 (G2542 ##)

Item	Stock No.	Description	Quantity			
			12	24	34	46
1	32 05 001	Pipe, PE2406, 2"	X			
	32 05 008	Pipe, PE2406, 4"		X	X	
	32 05 017	Pipe, PE2406, 6"				X
2	19 17 302	Transition Fitting, PE2406 to Steel, 1 1/4", with Protective Sleeve	1			
	19 17 129	Transition Fitting, PE2406 to Steel, 2", with Protective Sleeve		1		
	19 17 130	Transition Fitting, PE2406 to Steel, 3", with Protective Sleeve			1	
	19 17 131	Transition Fitting, PE2406 to Steel, 4", with Protective Sleeve				1
3	19 12 476	Fitting, Stopper, 1 1/4", Steel, Weld, Mueller	1			
	19 12 477	Fitting, Stopper, 2", Steel, Weld, Mueller		1		
	19 33 015	Fitting, Stopper, 3", Steel, Weld, Mueller			1	
	19 23 148	Fitting, Stopper, 4", Steel, Weld, Mueller				1
4	18 66 369	Wire Detector, # 12 AWG, TW, Cu.	X	X	X	X
5	19 17 324	Reducer, PE2406, 1 1/4" X 2", Butt Fusion	1			
	19 17 064	Reducer, PE2406, 2" X 4", Butt Fusion		1		
	19 17 066	Reducer, PE2406, 3" X 4", Butt Fusion			1	
	19 17 067	Reducer, PE2406, 4" X 6", Butt Fusion				1

X - Number of feet required for specific installation

Table 10
Steel to High Density PE Pipe Increasing Size

PE3408 (G2642 ##)						
Item	Stock No.	Description	Quantity			
			24	46		
1	32 22 021	Pipe, PE3408, 4"	X			
	32 22 022	Pipe, PE3408, 6"			X	
2	19 22 106	Transition Fitting, PE3408 to Steel, 2", with Protective Sleeve	1			
	19 22 109	Transition Fitting, PE3408 to Steel, 4", with Protective Sleeve			1	
3	19 12 477	Fitting, Stopper, 2", Steel, Weld, Mueller	1			
	19 23 148	Fitting, Stopper, 4", Steel, Weld, Mueller			1	
4	18 66 369	Wire Detector, # 12 AWG, TW, Cu.	X	X		
5	19 22 235	Reducer, PE3408, 2" X 4", Butt Fusion	1			
	19 22 236	Reducer, PE3408, 4" X 6", Butt Fusion			1	

X - Number of feet required for specific installation

B-3. Mueller Stopper - Steel to PE Pipe Decreasing Size

B-3.1 Installation (See [Figure 6](#))

B-3.1.1 Contact the local operating center and verify compatibility of tapping and stopping equipment before calling for the installation of this standard.

B-3.1.2 The final tie-in weld shall be butt or socket weld. Socket weld is approved for 2 inch and smaller pipe.

B-3.1.3 If protective sleeve is install it shall be placed over the transition fitting.
See Figure 6.

B-3.1.4 See [TAPS 2.4](#) for minimum cutting/welding distances to prevent damage to stopper.

B-3.2 Approved materials are listed in [Table 11](#) and [Table 12](#).

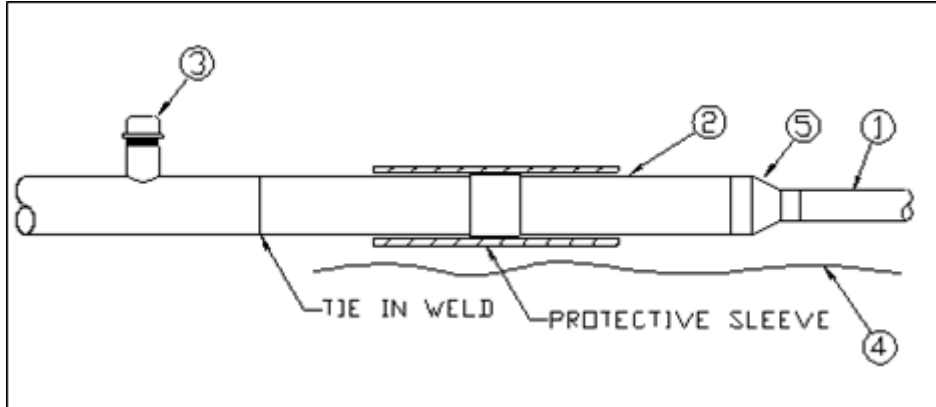

Figure 6

Mueller Stopper and Steel Transition Fitting to PE Pipe – Decreasing Size

Table 11

Steel to Medium Density PE Pipe Decreasing Size

PE2406 (G2543 ##)				
Item	Stock No.	Description	Quantity	
			32	42
1	32 05 001	Pipe, PE2406, 2"	X	X
2	19 17 130	Transition Fitting, PE2406 to Steel, 3", with Protective Sleeve	1	
	19 17 131	Transition Fitting, PE2406 to Steel, 4", with Protective Sleeve		1
3	19 33 015	Fitting, Stopper, 3", Steel, Weld, Mueller	1	
	19 23 148	Fitting, Stopper, 4", Steel, Weld, Mueller		1
4	18 66 369	Wire Detector, # 12 AWG, TW, Cu.	X	X
5	19 17 062	Reducer, PE2406, 3" X 2", Butt Fusion	1	
	19 17 064	Reducer, PE2406, 4" X 2", Butt Fusion		1

X - Number of feet required for specific installation

Table 12

Steel to High Density PE Pipe Decreasing Size

PE3408 (G2643 ##)			
Item	Stock No.	Description	Quantity
			42
1	32 22 020	Pipe, PE3408, 2"	X
2	19 22 109	Transition Fitting, PE3408 to Steel, 4", with Protective Sleeve	1
3	19 23 148	Fitting, Stopper, 4", Steel, Weld, Mueller	1
4	18 66 369	Wire Detector, # 12 AWG, TW, Cu.	X

5	19 22 235	Reducer, PE3408, 4" X 2", Butt Fusion	1
---	-----------	---------------------------------------	---

X - Number of feet required for specific installation

B-4. TDW Stopper - Steel to PE Pipe

B-4.1 Installation (See [Figure 7](#))

B-4.1.1 Contact the local operating center and verify compatibility of tapping and stopping equipment before calling for the installation of this standard.

B-4.1.2 The final tie-in weld shall be butt or socket weld. Socket weld is approved for 2 inch and smaller pipe.

B-4.1.3 If protective sleeve is install it shall be placed over the transition fitting. See Figure 7.

B-4.1.4 See [TAPS 2.5](#) for minimum cutting/welding distances to prevent damage to stopper.

B-4.2 Approved materials are listed in [Table 13](#) and [Table 14](#).

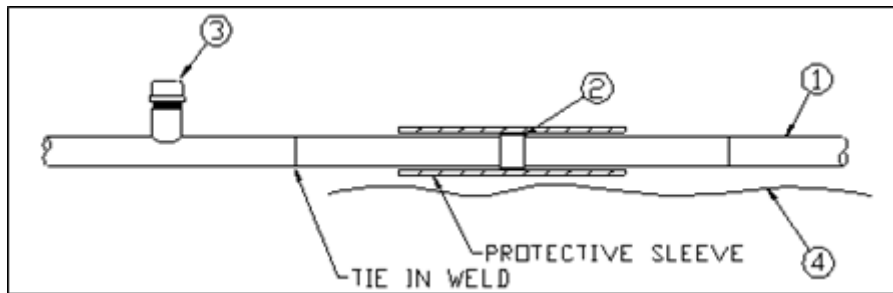

Figure 7

TDW Stopper and Steel Transition Fitting to PE Pipe

Table 13

Steel to Medium Density PE Pipe using a TDW Stopper

PE2406 (G2551 ##)						
Item	Stock No.	Description	Quantity			
			22	44	66	88
1	32 05 001	Pipe, PE2406, 2"	X			
	32 05 008	Pipe, PE2406, 4"		X		
	32 05 017	Pipe, PE2406, 6"			X	
	32 05 018	Pipe, PE2406, 8"				X
2	19 17 129	Transition Fitting, PE2406 to Steel, 2", with Protective Sleeve	1			
	19 17 131	Transition Fitting, PE2406 to Steel, 4", with Protective Sleeve		1		
	19 17 132	Transition Fitting, PE2406 to Steel, 6", with Protective Sleeve			1	
	19 17 336	Transition Fitting, PE2406 to Steel, 8", with Protective Sleeve				1
3	19 12 144	Fitting, Shortstopp, 2", Steel, Weld, Class 150, TDW	1			
	19 12 663	Fitting, Shortstopp, 4", Steel, Weld, Class 150, TDW		1		
	19 23 534	Fitting, Shortstopp, 6", Steel, Weld, Class 150, TDW			1	
	19 23 544	Fitting, Shortstopp, 8", Steel, Weld, Class 150, TDW				1

4	18 66 369	Wire Detector, # 12 AWG, TW, Cu.	X	X	X	X
---	-----------	----------------------------------	---	---	---	---

X - Number of feet required for specific installation

Table 14
Steel to High Density PE Pipe using a TDW Stopper

PE3408 (G2651 ##)						
Item	Stock No.	Description	Quantity			
			22	44	66	
1	32 22 020	Pipe, PE3408, 2"	X			
	32 22 021	Pipe, PE3408, 4"		X		
	32 22 022	Pipe, PE3408, 6"			X	
2	19 22 106	Transition Fitting, PE3408 to Steel, 2", with Protective Sleeve	1			
	19 22 109	Transition Fitting, PE3408 to Steel, 4", with Protective Sleeve		1		
	19 22 111	Transition Fitting, PE3408 to Steel, 6", with Protective Sleeve			1	
3	19 12 144	Fitting, Shortstopp, 2", Steel, Weld, Class 150, TDW	1			
	19 12 663	Fitting, Shortstopp, 4", Steel, Weld, Class 150, TDW		1		
	19 23 534	Fitting, Shortstopp, 6", Steel, Weld, Class 150, TDW			1	
4	18 66 369	Wire Detector, # 12 AWG, TW, Cu.	X	X	X	

X - Number of feet required for specific installation

B-5. TDW Stopper - Steel to PE Pipe Increasing Size (See [Figure 8](#))

B-5.1 Installation

- B-5.1.1 Contact the local operating center and verify compatibility of tapping and stopping equipment before calling for the installation of this standard.
- B-5.1.2 The final tie-in weld shall be butt or socket weld. Socket weld is approved for 2 inch and smaller pipe.
- B-5.1.3 If protective sleeve is install it shall be placed over the transition fitting. See [Figure 8](#).
- B-5.1.4 See [TAPS 2.5](#) for minimum cutting/welding distances to prevent damage to stopper.

B-5.2 Approved materials are listed in [Table 15](#) and [Table 16](#).

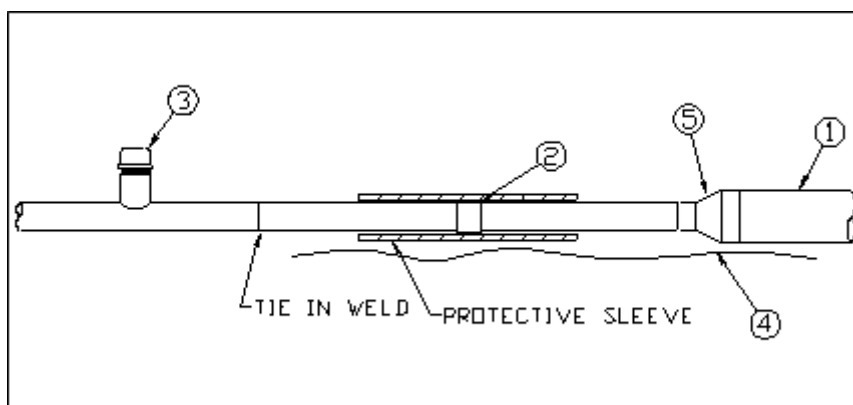

Figure 8

UNCONTROLLED IF PRINTED

TDW Stopper and Steel Transition Fitting to PE Pipe - Increasing Size

Table 15

Steel to Medium Density PE Pipe Increasing Size

PE2406 (G2552 ##)							
Item	Stock No.	Description	Quantity				
			12	24	34	46	68
1	32 05 001	Pipe, PE2406, 2"	X				
	32 05 008	Pipe, PE2406, 4"		X	X		
	32 05 017	Pipe, PE2406, 6"				X	
	32 05 018	Pipe, PE2406, 8"					X
2	19 17 302	Transition Fitting, PE2406 to Steel, 1 1/4", with Protective Sleeve	1				
	19 17 129	Transition Fitting, PE2406 to Steel, 2", with Protective Sleeve		1			
	19 17 130	Transition Fitting, PE2406 to Steel, 3", with Protective Sleeve			1		
	19 17 131	Transition Fitting, PE2406 to Steel, 4", with Protective Sleeve				1	
	19 17 132	Transition Fitting, PE2406 to Steel, 6", with Protective Sleeve					1
3	19 23 172	Fitting, Shortstopp, 1 1/4", Steel, Weld, TDW	1				
	19 12 144	Fitting, Shortstopp, 2", Steel, Weld, TDW		1			
	19 23 175	Fitting, Shortstopp, 3", Steel, Weld, TDW			1		
	19 12 663	Fitting, Shortstopp, 4", Steel, Weld, TDW				1	
	19 23 534	Fitting, Shortstopp, 6", Steel, Weld, TDW					1
4	18 66 369	Wire Detector, # 12 AWG, TW, Cu.	X	X	X	X	X
5	19 17 324	Reducer, PE2406, 1 1/4" X 2", Butt Fusion	1				
	19 17 064	Reducer, PE2406, 2" X 4", Butt Fusion		1			
	19 17 066	Reducer, PE2406, 3" X 4", Butt Fusion			1		
	19 17 067	Reducer, PE2406, 4" X 6", Butt Fusion				1	
	19 17 068	Reducer, PE2406, 6" X 8", Butt Fusion					1

X - Number of feet required for specific installation

Table 16

Steel to High Density PE Pipe Increasing Size

PE3408 (G2652 ##)				
Item	Stock No.	Description	Quantity	
			24	46
1	32 22 021	Pipe, PE3408, 4"	X	
	32 22 022	Pipe, PE3408, 6"		X
2	19 22 106	Transition Fitting, PE3408 to Steel, 2", with Protective Sleeve	1	
	19 22 109	Transition Fitting, PE3408 to Steel, 4", with Protective Sleeve		1
3	19 12 144	Fitting, Shortstopp, 2", Steel, Weld, TDW	1	
	19 12 663	Fitting, Shortstopp, 4", Steel, Weld, TDW		1
4	18 66 369	Wire Detector, # 12 AWG, TW, Cu.	X	X
5	19 22 235	Reducer, PE3408, 2" X 4", Butt Fusion	1	
	19 22 236	Reducer, PE3408, 4" X 6", Butt Fusion		1

X - Number of feet required for specific installation

UNCONTROLLED IF PRINTED

B-6. TDW Stopper - Steel to PE Pipe Decreasing Size (See [Figure 9](#))

B-6.1 Installation

B-6.1.1 Contact the local operating center and verify compatibility of tapping and stopping equipment before calling for the installation of this standard.

B-6.1.2 The final tie-in weld shall be butt or socket weld. Socket weld is approved for 2 inch and smaller pipe.

B-6.1.3 If protective sleeve is install it shall be placed over the transition fitting. See [Figure 9](#).

B-6.1.4 See [TAPS 2.5](#) for minimum cutting/welding distances to prevent damage to stopper.

B-6.2 Approved materials are listed in [Table 17](#) and [Table 18](#).

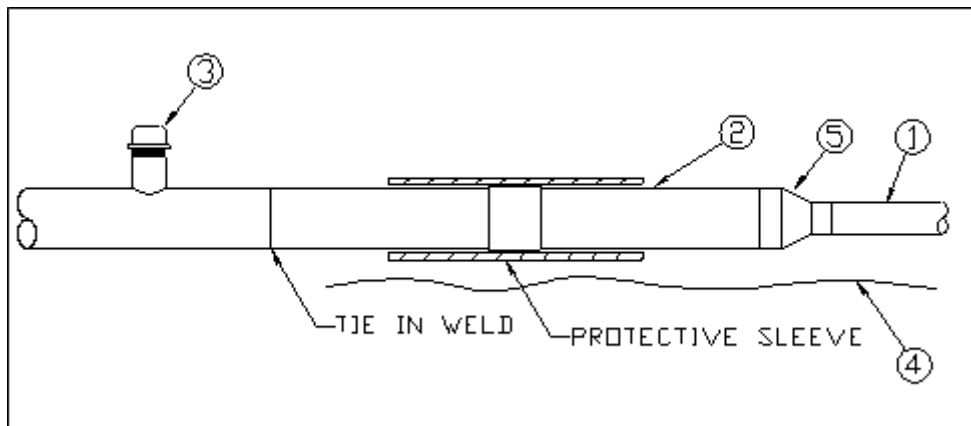

Figure 9

TDW Stopper and Steel Transition Fitting to PE Pipe - Decreasing Size

Table 17

Steel to to Medium Density PE Pipe Decreasing Size

PE2406 (G2553 ##)						
Item	Stock No.	Description	Quantity			
			32	42	64	86
1	32 05 001	Pipe, PE2406, 2"	X	X		
	32 05 008	Pipe, PE2406, 4"			X	
	32 05 017	Pipe, PE2406, 6"				X
2	19 17 130	Transition Fitting, PE2406 to Steel, 3", with Protective Sleeve	1			
	19 17 131	Transition Fitting, PE2406 to Steel, 4", with Protective Sleeve		1		
	19 17 132	Transition Fitting, PE2406 to Steel, 6", with Protective Sleeve			1	
	19 17 336	Transition Fitting, PE2406 to Steel, 8", with Protective Sleeve				1
3	19 23 175	Fitting, Shortstopp, 3", Steel, Weld, TDW	1			
	19 12 663	Fitting, Shortstopp, 4", Steel, Weld, TDW		1		
	19 23 534	Fitting, Shortstopp, 6", Steel, Weld, TDW			1	
	19 23 544	Fitting, Shortstopp, 8", Steel, Weld, TDW				1
4	18 66 369	Wire Detector, # 12 AWG, TW, Cu.	X	X	X	X
5	19 17 062	Reducer, PE2406, 3" X 2", Butt Fusion	1			

19 17 064	Reducer, PE2406, 4" X 2", Butt Fusion		1	
19 17 067	Reducer, PE2406, 6" X 4", Butt Fusion			1
19 17 068	Reducer, PE2406, 8" X 6", Butt Fusion			1

X - Number of feet required for specific installation

Table 18
Steel to High Density PE Pipe Decreasing Size

PE3408 (G2653 ##)				
Item	Stock No.	Description	Quantity	
			42	64
1	32 22 020	Pipe, PE3408, 2"	X	
	32 22 021	Pipe, PE3408, 4"		X
2	19 22 109	Transition Fitting, PE3408 to Steel, 4", with Protective Sleeve	1	
	19 22 111	Transition Fitting, PE3408 to Steel, 6", with Protective Sleeve		1
3	19 12 663	Fitting, Shortstopp, 4", Steel, Weld, TDW	1	
	19 23 534	Fitting, Shortstopp, 6", Steel, Weld, TDW		1
4	18 66 369	Wire Detector, # 12 AWG, TW, Cu.	X	X
5	19 22 235	Reducer, PE3408, 4" X 2", Butt Fusion	1	
	19 22 236	Reducer, PE3408, 6" X 4", Butt Fusion		1

X - Number of feet required for specific installation

Appendix C - Main Extension - Steel to Steel Pipe

C-1. Mueller Stopper (See [Figure 10](#))

C-1.1 Installation

C-1.1.1 Contact the local operating center and verify compatibility of tapping and stopping equipment before calling for the installation of this standard.

C-1.1.2 The final tie-in weld shall be butt or socket weld. Socket weld is approved for 2 inch and smaller pipe. If necessary, use a transition weld fitting.

C-1.1.3 Ensure that the stopper fitting has an adequate pressure rating for the pipeline to which it is being used.

C-1.1.4 See [TAPS 2.4](#) for minimum cutting/welding distances to prevent damage to stopper.

C-1.2 Approved materials are listed in [Table 19](#).

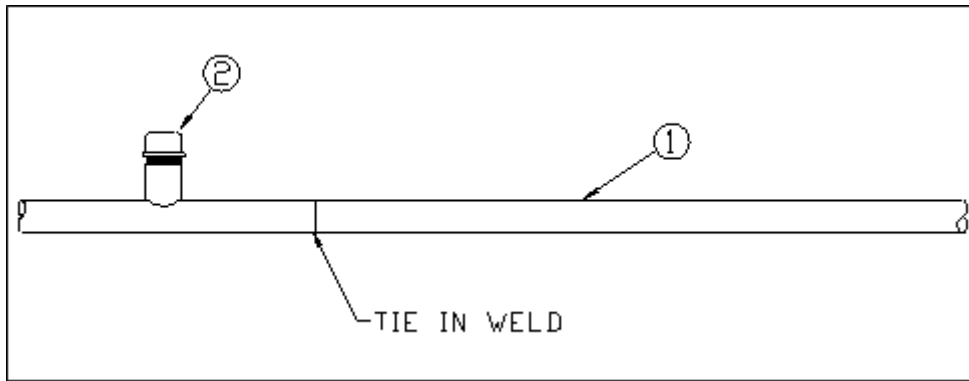

Figure 10
Steel to Steel with Mueller Stopper

Table 19
Steel to Steel Pipe with Mueller Stopper

(G2711 ##)				
Item	Stock No.	Description	Quantity	
			22	44
1	32 23 319	Pipe, Steel, 2"	X	
	32 23 330	Pipe, Steel, 4"		X
2	19 12 477	Fitting, Stopper, 2", Steel, Weld, Mueller	1	
	19 23 148	Fitting, Stopper, 4", Steel, Weld, Mueller		1

X - Number of feet required for specific installation

C-2. Mueller Stopper - Steel to Steel Pipe Increasing Size (See [Figure 11](#))

C-2.1 Installation

- C-2.1.1 Contact the local operating center and verify compatibility of tapping and stopping equipment before calling for the installation of this standard.
- C-2.1.2 The final tie-in weld shall be butt or socket weld. Socket weld is approved for 2 inch and smaller pipe. If necessary, use a transition weld fitting.
- C-2.1.3 Ensure that the stopper fitting has an adequate pressure rating for the pipeline to which it is being used.
- C-2.1.4 See [TAPS 2.4](#) for minimum cutting/welding distances to prevent damage to stopper.

C-2.2 Approved materials are listed in [Table 20](#).

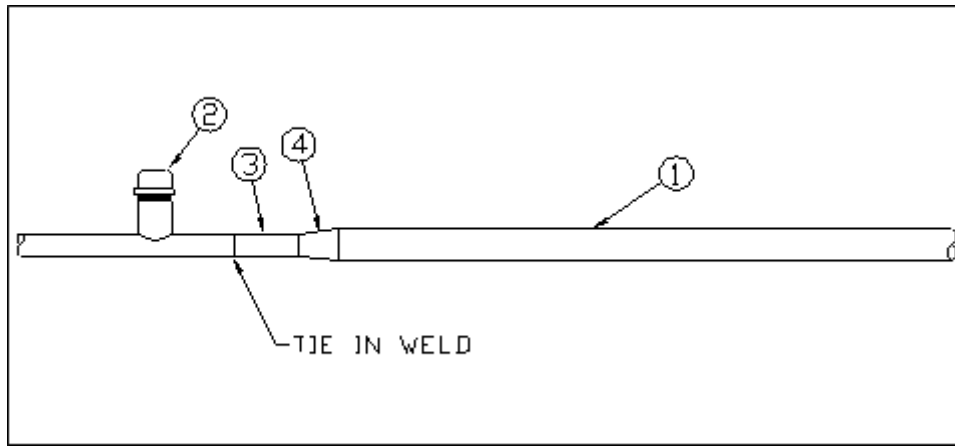

Figure 11

Steel to Steel Increasing Size - Mueller Stopper

Table 20

Steel to Steel Pipe Increasing Size with Mueller Stopper

(G2712 ##)						
Item	Stock No.	Description	Quantity			
			12	24	34	46
1	32 23 319	Pipe, Steel, 2"	X			
	32 23 330	Pipe, Steel, 4"		X	X	
	32 23 340	Pipe, Steel, 6"				X
2	19 12 476	Fitting, Stopper, 1 ¼", SteelWeld, Mueller	1			
	19 12 477	Fitting, Stopper, 2", Steel, Weld, Mueller		1		
	19 33 015	Fitting, Stopper, 3", Steel, Weld, Mueller			1	
	19 23 148	Fitting, Stopper, 4", Steel, Weld, Mueller				1
3	32 23 312	Pipe, Steel, 1 ¼"	X			
	32 23 319	Pipe, Steel, 2"		X		
	32 23 197	Pipe, Steel, 3"			X	
	32 23 330	Pipe, Steel, 4"				X
4	19 08 558	Reducer, Steel, 1 ¼" X 2", Weld	1			
	19 33 652	Reducer, Steel, 2" X 4", Weld		1		
	19 12 254	Reducer, Steel, 3" X 4", Weld			1	
	19 33 653	Reducer, Steel, 4" X 6", Weld				1

X - Number of feet required for specific installation

C-3. Mueller Stopper - Steel to Steel Pipe Decreasing Size (See [Figure 12](#))

C-3.1 Installation

C-3.1.1 Contact the local operating center and verify compatibility of tapping and stopping equipment before calling for the installation of this standard.

C-3.1.2 The final tie-in weld shall be butt or socket weld. Socket weld is approved for 2 inch and smaller pipe. If necessary, use a transition weld fitting.

C-3.1.3 Ensure that the stopper fitting has an adequate pressure rating for the pipeline to which it is being used.

C-3.1.4 See [TAPS 2.4](#) for minimum cutting/welding distances to prevent damage to stopper.

C-3.2 Approved materials are listed in [Table 21](#).

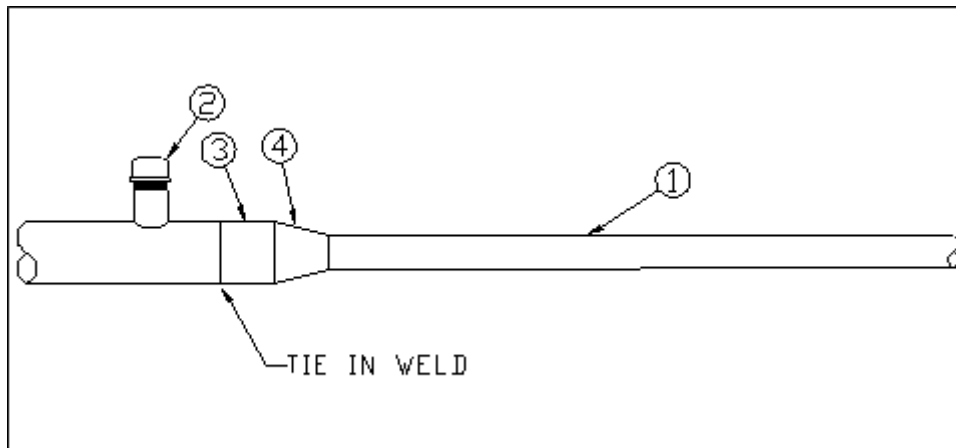

Figure 12

Steel to Steel Decreasing Size - Mueller Stopper

Table 21

Steel to Steel Pipe Decreasing Size with Mueller Stopper

(G2713 ##)				
Item	Stock No.	Description	Quantity	
			32	42
1	32 23 319	Pipe, Steel, 2"	X	X
2	19 33 015	Fitting, Stopper, 3", Steel, Weld, Mueller	1	
	19 23 148	Fitting, Stopper, 4", Steel, Weld, Mueller		1
3	32 23 197	Pipe, Steel, 3"	X	
	32 23 330	Pipe, Steel, 4"		X
4	19 33 148	Reducer, Steel, 3" X 2", Weld	1	
	19 33 652	Reducer, Steel, 4" X 2", Weld		1

X - Number of feet required for specific installation

C-4. TDW Stopper (See [Figure 13](#))

C-4.1 Installation

C-4.1.1 Contact the local operating center and verify compatibility of tapping and stopping equipment before calling for the installation of this standard.

C-4.1.2 The final tie-in weld shall be butt or socket weld. Socket weld is approved for 2 inch and smaller pipe. If necessary, use a transition weld fitting.

C-4.1.3 Ensure that the Shortstopp fitting has an adequate pressure rating for the pipeline to which it is being used.

C-4.1.4 See [TAPS 2.5](#) for minimum cutting/welding distances to prevent damage to stopper.

C-4.2 Approved materials are listed in [Table 22](#).

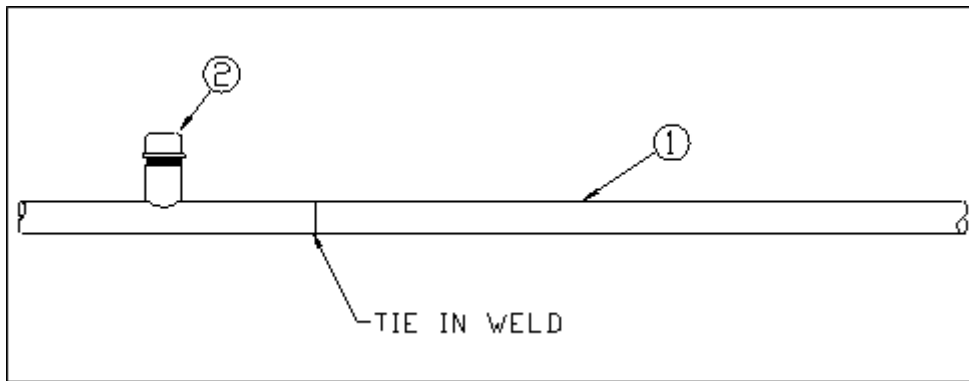

Figure 13

Steel to Steel with TDW Stopper

Table 22

Steel to Steel Pipe with TDW Stopper

(G2721 ##)						
Item	Stock No.	Description	Quantity			
			22	44	66	88
1	32 23 319	Pipe, Steel, 2"	X			
	32 23 330	Pipe, Steel, 4"		X		
	32 23 341	Pipe, Steel, 6"			X	
	32 23 348	Pipe, Steel, 8"				X
2	19 12 144	Fitting, Shortstopp, 2", Steel, Weld, TDW	1			
	19 12 663	Fitting, Shortstopp, 4", Steel, Weld, TDW		1		
	19 23 534	Fitting, Shortstopp, 6", Steel, Weld, TDW			1	
	19 23 544	Fitting, Shortstopp, 8", Steel, Weld, TDW				1

X - Number of feet required for specific installation

C-5. TDW Stopper - Steel to Steel Pipe Increasing Size (See [Figure 14](#))

C-5.1 Installation

C-5.1.1 Contact the local operating center and verify compatibility of tapping and stopping equipment before calling for the installation of this standard.

C-5.1.2 The final tie-in weld shall be butt or socket weld. Socket weld is approved for 2 inch and smaller pipe. If necessary, use a transition weld fitting.

C-5.1.3 Ensure that the Shortstopp fitting has an adequate pressure rating for the pipeline to which it is being used.

C-5.1.4 See [TAPS 2.5](#) for minimum cutting/welding distances to prevent damage to stopper.

C-5.2 Approved materials are listed in [Table 23](#).

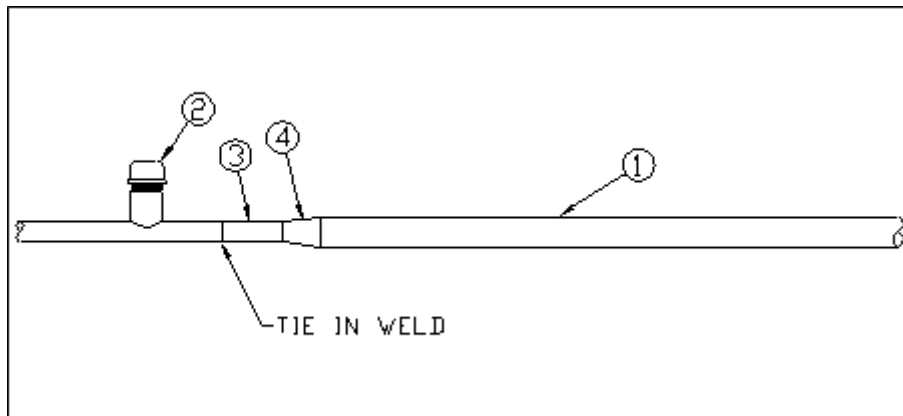

Figure 14

Steel to Steel Increasing Size - TDW Stopper

Table 23

Steel to Steel Pipe Increasing Size with TDW Stopper

(G2722 ##)							
Item	Stock No.	Description	Quantity				
			12	24	34	46	68
1	32 23 319	Pipe, Steel, 2"	X				
	32 23 330	Pipe, Steel, 4"		X	X		
	32 23 340	Pipe, Steel, 6"				X	
	32 23 348	Pipe, Steel, 8"					X
2	19 23 172	Fitting, Shortstopp, 1 1/4", Steel, Weld, TDW	1				
	19 12 144	Fitting, Shortstopp, 2", Steel, Weld, TDW		1			
	19 23 175	Fitting, Shortstopp, 3", Steel, Weld, TDW			1		
	19 12 663	Fitting, Shortstopp, 4", Steel, Weld, TDW				1	
	19 23 534	Fitting, Shortstopp, 6", Steel, Weld, TDW					1
3	32 23 312	Pipe, Steel, 1 1/4"	X				
	32 23 319	Pipe, Steel, 2"		X			
	32 23 197	Pipe, Steel, 3"			X		
	32 23 330	Pipe, Steel, 4"				X	
	32 23 340	Pipe, Steel, 6"					X
4	19 08 558	Reducer, Steel, 1 1/4" X 2", Weld	1				
	19 33 652	Reducer, Steel, 2" X 4", Weld		1			

UNCONTROLLED IF PRINTED

19 12 254	Reducer, Steel, 3" X 4", Weld			1	
19 33 653	Reducer, Steel, 4" X 6", Weld				1
19 08 565	Reducer, Steel, 6" X 8", Weld				1

X - Number of feet required for specific installation

C-6 TDW Stopper - Steel to Steel Pipe Decreasing Size (See [Figure 15](#))

C-6.1 Installation

C-6.1.1 Contact the local operating center and verify compatibility of tapping and stopping equipment before calling for the installation of this standard.

C-6.1.2 The final tie in weld shall be butt or socket weld. Socket weld is approved for 2 inch and smaller pipe. If necessary use a transition weld fitting.

C-6.1.3 Ensure that the Shortstopp fitting has an adequate pressure rating for the pipeline to which it is being used.

C-6.1.4 See [TAPS 2.5](#) for minimum cutting/welding distances to prevent damage to stopper.

C-6.2 Approved materials are listed in [Table 24](#).

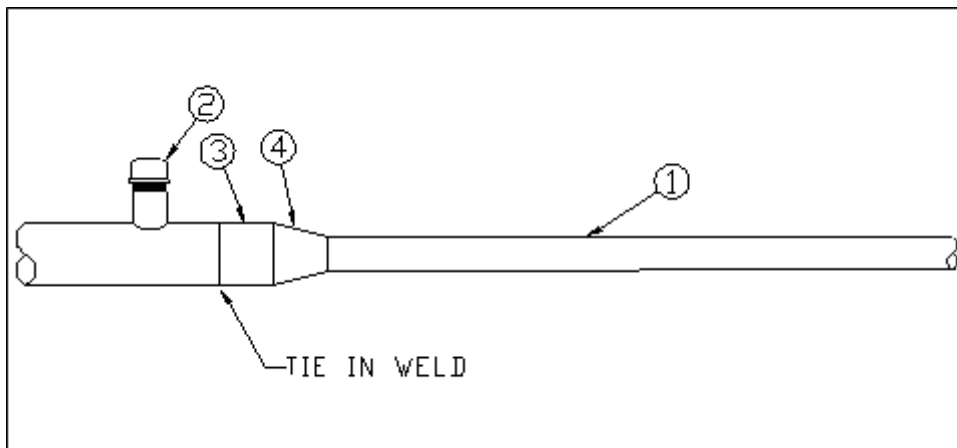

Figure 15

Steel to Steel Decreasing Size - TDW Stopper

Table 24

Steel to Steel Pipe Decreasing Size with TDW Stopper

(G2723 ##)						
Item	Stock No.	Description	Quantity			
			32	42	64	86
1	32 23 319	Pipe, Steel, 2"	X	X		
	32 23 330	Pipe, Steel, 4"			X	
	32 23 340	Pipe, Steel, 6"				X
2	19 23 175	Fitting, Shortstopp, 3", Steel, Weld, TDW	1			

UNCONTROLLED IF PRINTED

	19 12 663	Fitting, Shortstopp, 4", Steel, Weld, TDW		1		
	19 23 534	Fitting, Shortstopp, 6", Steel, Weld, TDW			1	
	19 23 544	Fitting, Shortstopp, 8", Steel, Weld, TDW				1
3	32 23 197	Pipe, Steel, 3"	X			
	32 23 319	Pipe, Steel, 4"		X		
	32 23 340	Pipe, Steel, 6"			X	
	32 23 348	Pipe, Steel, 8"				X
4	19 33 148	Reducer, Steel, 3" X 2", Weld	1			
	19 33 652	Reducer, Steel, 4" X 2", Weld		1		
	19 33 653	Reducer, Steel, 6" X 4", Weld			1	
	19 08 565	Reducer, Steel, 8" X 6", Weld				1

X - Number of feet required for specific installation

METR-Metering

METERING

October 1, 2022

METR 0 Table of Contents

[METR 1 Metering: Requirements](#)

- Section 1.0 Purpose
- Section 2.0 Scope
- Section 3.0 Target Audience
- Section 4.0 General
- Section 5.0 Care and Handling
- Section 6.0 Gas Meter Location
- Section 7.0 Installation
- Section 8.0 Regulator Vent Lines
- Section 9.0 Painting Meter Sets
- Section 10.0 Scheduled Removal of Inactive Meters
- Section 11.0 Removed Meters
- Operator Qualification (OQ)
- Compliance Requirements
- Reference Documents
- Document Rescission

[METR 2.1 Metering: Replacement and Retirement](#)

- Section 1.0 Purpose
- Section 2.0 Scope
- Section 3.0 Target Audience
- Section 4.0 Obsolete Meters
- Section 5.0 Meter Retirements
- Section 6.0 Meter Exchanges
- Section 7.0 Large-Volume Diaphragm Meter Replacement
- Section 8.0 Meters Removed from Field
- Section 9.0 Obstructions at Worksite
- Section 10.0 Painting Meter Set
- Section 11.0 Reporting

UNCONTROLLED IF PRINTED

Operator Qualification (OQ)

Appendices

Appendix A - Postcard Contact

Appendix B - Letter Contact

Compliance Requirements

Reference Documents

Document Rescission

METR 2.2 Metering: Meter Inspection and Testing - Field

Section 1.0 Purpose

Section 2.0 Scope

Section 3.0 Target Audience

Section 4.0 Sample Testing

Section 5.0 Periodic Testing

Section 6.0 Customer Requested Test

Section 7.0 Meter Header Inspection

Section 8.0 Records and Retention

Operator Qualification (OQ)

Appendices

Appendix A - AC Voltage Potential at Meter Set

Appendix B - Regulator Related Pictures

Compliance Requirements

Reference Documents

Document Rescission

METR 2.3 Metering: Meter Inspection and Testing - Shop

Section 1.0 Purpose

Section 2.0 Scope

Section 3.0 Target Audience

Section 4.0 General

Section 5.0 Prover Certification

Section 6.0 Bell Prover Testing -- Not Used by AIC

Section 7.0 Transfer Prover Testing

Section 8.0 New Meter Testing

Section 9.0 Records and Retention

Operator Qualification (OQ)

Appendices

UNCONTROLLED IF PRINTED

Appendix A - Meter Flow Rates

Compliance Requirements

Reference Documents

Document Rescission

METR 2.4 Metering: Meter Inspection and Testing - GTS

Section 1.0 Purpose

Section 2.0 Scope

Section 3.0 Target Audience

Section 4.0 General

Section 5.0 Rotary Meter Differential Testing

Section 6.0 Turbine Meter Testing

Section 7.0 Ultrasonic Meter Testing

Section 8.0 Records and Retention

Operator Qualification (OQ)

Compliance Requirements

Reference Documents

Document Rescission

METR 2.5 Metering: Gas Meter Bypass

Section 1.0 Purpose

Section 2.0 Scope

Section 3.0 Target Audience

Section 4.0 Basic Procedure

Section 5.0 Using Portable CNG Tank System with Angled-System Bypass Valve

Section 6.0 Using Portable CNG Tank with Grunsky Apparatus

Section 7.0 Using Portable CNG Tank with the Mueller Brisco Valve

Section 8.0 Refilling Portable CNG Tanks

Operator Qualification (OQ)

Compliance Requirements

Reference Documents

Document Rescission

METR 2.6 Metering: Pressure Gauges

Section 1.0 Purpose

Section 2.0 Scope

Section 3.0 Target Audience

UNCONTROLLED IF PRINTED

Section 4.0 General

Section 5.0 Gauge Definitions

Section 6.0 Use of Test Gauges

Section 7.0 Use of Calibrating Gauges (Portable Standard)

Section 8.0 Verification and Calibration

Section 9.0 Reference Standard

Section 10.0 Recordkeeping

Operator Qualification (OQ)

Appendices

Appendix A - Gauge Accuracy Verification

Compliance Requirements

Reference Documents

Document Rescission

METR 2.7 Metering: Gas Metering Corrections

Section 1.0 Purpose

Section 2.0 Scope

Section 3.0 Target Audience

Section 4.0 General

Section 5.0 Electronic Corrector Inspection-Verification Schedule

Section 6.0 Pressure Verification

Section 7.0 Temperature Verification

Section 8.0 AMI Reading Verification

Section 9.0 Gas Correcting Edits

Section 10.0 Maintenance Activity

Section 11.0 Atmospheric Corrosion Inspection / Follow-up

Section 12.0 Records

Operator Qualification (OQ)

Appendices

Appendix A - Electronic Corrector Documentation

Appendix B - Electronic Corrector Maintenance

Appendix C - Electronic Corrector Verification Form

Appendix D - Electronic Corrector Inspection Form

Compliance Requirements

Reference Documents

Document Rescission

UNCONTROLLED IF PRINTED

METR 2.8 Metering: Pressure Factor Metering

- Section 1.0 Purpose
- Section 2.0 Scope
- Section 3.0 Target Audience
- Section 4.0 General
- Section 5.0 Elevated Metering Pressure Considerations
- Section 6.0 Pressure Factor Metering
- Section 7.0 Pressure Factors
- Section 8.0 Electronic Correctors
- Section 9.0 Verification Process
- Section 10.0 Other Related Actions
- Section 11.0 Records
- Operator Qualification (OQ)
- Compliance Requirements
- Reference Documents
- Document Rescission

METR 2.9 Metering: Diaphragm Meter Repair

- Section 1.0 Purpose
- Section 2.0 Scope
- Section 3.0 Target Audience
- Section 4.0 General
- Section 5.0 Meter Repair Procedures
- Section 6.0 Contract Meter Repair - General
- Section 7.0 Contract Meter Repair - Equipment
- Section 8.0 Contractor Repair Specifications
- Section 9.0 Other Terms and Conditions - Contracted Repairs
- Section 10.0 Contractor Quotations
- Operator Qualification (OQ)
- Appendices
 - Appendix A - Domestic Meter "Class A" Repair - American & Rockwell
 - Appendix B - Domestic Meter "Class B" Repair:
 - Appendix B-1 - American & Rockwell Meters
 - Appendix B-2 - Sprague Meters
- Compliance Requirements
- Reference Documents

UNCONTROLLED IF PRINTED

Document Rescission

METR 2.10 Metering: Gas Meter Data Sheet

Section 1.0 Purpose

Section 2.0 Scope

Section 3.0 Target Audience

Section 4.0 Gas Meter Data Sheet

Section 5.0 Completion Instructions

Section 6.0 Report Distribution

Section 7.0 Gas Metering Review WFM

Operator Qualification (OQ)

Appendices

Appendix A - GMDS Completion Instructions

Appendix B - Gas Meter Data Sheet

Compliance Requirements

Reference Documents

Document Rescission

METR 3.1 Metering: Meter Sizing

Section 1.0 Purpose

Section 2.0 Scope

Section 3.0 Target Audience

Section 4.0 Sizing Criteria

Section 5.0 Approved Meters for New Installations

Section 6.0 Existing Diaphragm Meter Installations

Section 7.0 Existing Rotary Meter Installations

Operator Qualification (OQ)

Appendices

Appendix A - Approved Meters for New Locations

Appendix B - Capacities for Existing Diaphragm Meter Installations (Tables B-1 thru B-4)

Appendix C - Capacities for Existing Rotary Meter Installations

Compliance Requirements

Reference Documents

Document Rescission

METR 3.2 Metering: Regulator Sizing

UNCONTROLLED IF PRINTED

Section 1.0 Purpose

Section 2.0 Scope

Section 3.0 Target Audience

Section 4.0 General

Section 5.0 Regulator Sizing @ 7" w.c. Delivery Pressure

Section 6.0 Regulator Sizing @ 2 psig Delivery Pressure

Section 7.0 Regulator Sizing @ 5 psig Delivery Pressure

Section 8.0 Regulator Sizing @ 10 psig Delivery Pressure

Section 9.0 Alternative Regulator Sizing @ Various Delivery Pressures

Operator Qualification (OQ)

Appendices

Appendix A - New Regulators for Installation @ 7" w.c. Delivery Pressure

Appendix B - New Regulators for Installation @ 2 psig Delivery Pressure

Appendix C - New Regulators for Installation @ 5 psig Delivery Pressure

Appendix D - New Regulators for Installation @ 10 psig Delivery Pressure

Appendix E - Alternative Regulator Sizing @ Various Delivery Pressures

Compliance Requirements

Reference Documents

Document Rescission

METR 3.3 Metering: Diaphragm Meter Sets

Section 1.0 Purpose

Section 2.0 Scope

Section 3.0 Target Audience

Section 4.0 Diaphragm Meter Sets (Appendices)

Appendix A - 175/250 Meter, 7" w.c. Delivery, 1-60 psig Inlet

Appendix B - 175/250 Meter, 2 psig Delivery, 5-60 psig Inlet

Appendix C - 175/250 Meter, 7" w.c. Delivery, 61-100 psig Inlet

Appendix D - 175/250 Meter, 2 psig Delivery, 61-100 psig Inlet

Appendix E - 425 Meter, 7" w.c. Delivery, 1-60 psig Inlet

Appendix F - 425 Meter, Bypass, 7" w.c. Delivery, 1-60 psig Inlet

Appendix G - 425 Meter, Bypass, 2 & 5 psig Delivery, 15-60 psig Inlet

Appendix H - 630 Meter, 7" w.c. Delivery, 1-60 psig Inlet

Appendix I - 630 Meter, Bypass, 7" w.c. Delivery, 1-60 psig Inlet

Appendix J - 630 Meter, Bypass, 2, 5, & 10 psig Delivery, 5-60 psig Inlet

Appendix K - Multiple Meter Installation

UNCONTROLLED IF PRINTED

Operator Qualifications (OQ)

Appendices

(See Section 4.0 for List of Appendices A thru K (11 total))

Compliance Requirements

Reference Documents

Document Rescission

METR 3.4 Metering: Compact and Rotary Meter Sets

Section 1.0 Purpose

Section 2.0 Scope

Section 3.0 Target Audience

Section 4.0 Appendix List of Gas Meter Sets

Appendix A - 15C Compact Meter, 7" w.c. Delivery Pressure

Appendix B - 15C Compact Meter, 2 psig Delivery Pressure

Appendix C - 15C/3M Meter, 7" w.c. Delivery Pressure

Appendix D - 15C/3M Meter, 2 psig Delivery Pressure

Appendix E - 15C/3M Meter, 5 & 10 psig Delivery Pressure

Appendix F - 5M/7M Meter, 7" w.c. Delivery Pressure

Appendix G - 5M/7M Meter, 2 psig Delivery Pressure

Appendix H - 5M/7M Meter, 5 & 10 psig Delivery Pressure

Operator Qualification (OQ)

Appendices:

(See Section 4.0 for List of Appendices A thru H (8 total))

Compliance Requirements

Reference Documents

Document Rescission

METR 4 Metering: Forms and Reference Materials

Forms

References

Document Rescission

Appendices

Appendix A - Meter Test Schedules & Retention Requirements

Summary filed here in support of METR 2.2, 2.3, and 2.4.

End Table of Contents.

Document Rescission

METR 0 Metering – Table of Contents, October 1, 2020

Revision Notes

Location of Changes	Summary of Changes
METR 2.5	Added: Section 7.0 - Using Portable CNG Tank with the Mueller Brisco Valve (Actually added April 1, 2021) Section 8.0 - Refilling Portable CNG Tanks

METERING

April 1, 2023

METR 1 Requirements

1.0 Purpose

This document prescribes proper handling and installation of gas meters, auxiliary equipment, tertiary equipment, and regulators for Ameren Illinois (AIC) to ensure safe and accurate measurement of natural gas.

2.0 Scope

This document addresses the following:

[3.0 Target Audience](#)

[4.0 General](#)

[5.0 Care and Handling](#)

[6.0 Gas Meter Location](#)

[7.0 Installation](#)

[8.0 Regulator Vent Lines](#)

[9.0 Painting Meter Sets](#)

[10.0 Scheduled Removal of Inactive Meters](#)

[11.0 Removed Meters](#)

3.0 Target Audience

- Gas Engineering
- Gas Supervisors
- Gas Field Personnel
- Gas Technical Services (GTS) Supervisor
- Gas Meter Supervisor

4.0 General

4.1 Definitions

4.1.1 *Auxiliary Equipment* means an integral device attached directly or remotely to a gas meter. The function of auxiliary equipment is to adjust gas meter usage measurements for changes in gas temperature or pressure (e.g., correctors).

4.1.2 *Tertiary Equipment* means a device that electronically converts signals from a gas measurement system (meter or auxiliary equipment or both) to a useful form, such as flow rate (e.g., flow computers, remote monitoring devices (RMD)).

4.2 Sizing Tables

4.2.1 See Table 1 for sizing meters and regulators as approved for new installations.

Table 1: Sizing Table for Meters and Regulators, New Installations

Application	Section
Meter Sizing:	

New	METR 3.1
Existing	METR 3.1
Regulator Sizing: 7" w.c. Delivery Pressure	METR 3.2, Appendix A
2 psig Delivery Pressure	METR 3.2, Appendix B
5 psig Delivery Pressure	METR 3.2, Appendix C
10 psig Delivery Pressure	METR 3.2, Appendix D
Alternate Approved Regulators	METR 3.2, Appendix E

4.3 Where practical, no building should have more than one-meter location.

4.4 For installation requirements on the related service lines, see [SERV 1](#).

5.0 Care and Handling

5.1 The following equipment, as used to measure and report customer gas usage, shall be transported and handled in a manner that ensures the safe, proper, reliable, and accurate operation:

5.1.1 Gas Meters

5.1.2 Auxiliary Equipment (e.g., correctors)

5.1.3 Tertiary Equipment (e.g., remote meter display (RMD))

The care is to ensure that equipment is installed at a customer site in a manner to measure gas reliably and accurately.

5.2 Handling and Transporting Considerations

5.2.1 General

1. **Connections:** The inlet and outlet connections of gas meter shall always be capped or plugged when not in service.

Meters do not have to be capped when located in the meter proofing room, soaking room, or after they have been tested and waiting for repairs.

2. **Meters, auxiliary equipment, and tertiary equipment:** Items that have been dropped or excessively jarred should not be placed in service, but do the following:
 - 2 a. Identify this equipment as "dropped."
 - 2 b. Return equipment to the meter shop for testing and adjustment to verify it will operate correctly and record accurately.

5.2.2 **Transporting meters:** Haul meters in an upright position and secured in place.

UNCONTROLLED IF PRINTED

1. If possible, transport small diaphragm meters in the meter compartments of utility trucks.
 2. Make every effort to minimize the time meters are carried on trucks.
- 5.2.3 *Rotary and turbine meters*: Drain oil before transporting unit. Securely fasten in the transport vehicle.
- 5.2.4 *Correcting devices and other remote monitoring devices (RMDs)*: Carefully transport and handle prior to installation and after removal from service to prevent damage.
- 5.2.5 *Regulators*: Transport in utility truck compartments or secure in the transport vehicle.

Proper handling is critical when meters and auxiliary/tertiary equipment are removed from service so that subsequent accuracy test at the meter shop is representative of the unit accuracy when they were in service.

- 5.3 Gas meters removed as part of a "Sample Lot" shall be handled with extra care. The handling is especially critical as such meters are accuracy tested and the results used to statistically evaluate meter accuracy of an entire group of meters, which are commonly referred to as a "Sample Lot."

If sample meters are jarred, dropped, or improperly handled or transported, their accuracy can be affected - possibly resulting in inaccurate test results and failure of the gas meter Sample Lot. Such failure would then cause the entire Lot to be removed from service.

- 5.4 Meters that are not in service shall be stored in a secure, weather protected environment and stacked in an upright position in a manner recommended by the manufacturer.

The weather protected environment does not apply to utility vehicles used to transport meters.

6.0 Gas Meter Location

6.1 Residential Meters

- 6.1.1 New or relocated meter sets shall be located:
1. Immediately adjacent to and should be within 3 feet of an outside wall.
 2. In a location where venting gas will not accumulate.
 3. At a location readily accessible to AIC personnel during normal working hours and during an emergency.

- 6.1.2 New or relocated meters shall not be installed indoors unless an outdoor installation is not possible or would make meter installation financially impracticable.
- 6.1.3 If a new or relocated meter must be installed inside, it shall be as follows:
 - 1. As close to service line entrance as possible.
 - 2. Installed in a ventilated location.
 - 3. Installed not less than 3 feet from any ignition source, or any heat source which might damage the meter.
 - 4. Regulator must be located outside the building or in a separate meter or regulator building.

6.2 Commercial or Industrial Meters

- 6.2.1 Meter sets shall be installed in a location acceptable to the local Gas Supervisor or Gas Engineering.
- 6.2.2 Meters may be installed inside a designated meter building that is not used for human occupancy.

6.3 Unacceptable Meter Locations

- 6.3.1 In front of a building unless the property owner gives consent and there is no other suitable location.
- 6.3.2 In locations where the installation, reading, inspection, repairing, testing, changing, and removal of the meter could be difficult or hazardous.
- 6.3.3 In an unvented or inaccessible location.
- 6.3.4 In a bedroom, closet, bathroom, or small unventilated rooms.
- 6.3.5 Under stairways or fire escapes.
- 6.3.6 Within 3 feet of a heat source which could damage the meter or exposed the meter to temperatures that are outside those recommended by the manufacturer, typically higher than 140 °F or below -40 °F.
- 6.3.7 In direct contact with the soil, concrete, or other surfaces that will cause corrosion (unless the gas meter is designed for those conditions). This also applies to any auxiliary and tertiary equipment/instruments connected to the meter.
- 6.3.8 Directly under downspouts or other facilities that may cause icing conditions.
- 6.3.9 Under cooking equipment exhaust where cooking grease residue could coat the meter.
- 6.3.10 Where the service regulator vent is:
 - 1. Within 3 feet of any ignition source, such as:
 - 1 a. Electric meter base.
 - 1 b. Meter sockets.
 - 1 c. Electrical disconnect switches.
 - 1 d. Light switches and electrical receptacles.
 - 1 e. AC condensing unit.
 - 1 f. Heat pump.
 - 1 g. Stand-by generator.

UNCONTROLLED IF PRINTED

2. Above, below, or within 12 inches horizontally:
 - 2 a. To the side of a basement window that can be opened.
 - 2 b. First floor window that can be opened.
 - 2 c. Door.
 - 2 d. Stairs.
 - 2 e. Dryer vent.
 - 2 f. Gas appliance exhaust.
 - 2 g. Air intake/high efficiency gas appliance intake.
3. Where the service regulator cannot vent freely to the atmosphere.
4. If the requirements above cannot be reasonably met, consult with Supervising Engineer for approval to install an approved slam-shut regulator.

Approved Slam-Shut Regulators				
Model	Body Size	Delivery Pressure	Max Inlet Pressure	Stock Code
BelGas P100SX	1" x 1"	7" w.c	125 psig	62 06 495
PF – 25	1" x 1"	7" w.c	125 psig	62 06 496

- 4 a. Regulator capacity information is in [METR 3.2 Appendix A](#)
- 4 b. Manufacturer's Operating Manuals are in [METR 4](#)

6.4 Damage Protection

- 6.4.1 When practical, locate a newly installed or relocated gas meter in an area free of vehicular traffic.
- 6.4.2 Where meter is exposed to vehicular traffic or other outside forces, it shall be protected using guard posts or railings. See Table 2 for meter guards (prefab steel post) available through the AIC storeroom.

Table 2: Available Meter Guards - AIC Stock

Stock Code	Description
62 05 159	2-inch IPS legs and cross members
62 05 160	4-inch IPS legs and 2-inch IPS cross members
<i>Note:</i> See METR 4 for drawings of these prefab meter guards.	

- 6.4.3 To extent doable, provide protection from extreme weather elements, especially to regulators and related vents where there is potential for severe water or freezing conditions to interfere with regulator operation.
Example: Provide protection where ice or snow could come off roof and damage equipment.

6.5 AIC may relocate unacceptable meter sets (created by others) to an acceptable location at customer expense. An unacceptable location is one that violates the provisions of this standard or governing authority.

6.6 Refusal of Service

- 6.6.1 A meter or service may be refused to a customer if, in AIC judgement:

1. The metering installation is hazardous,
 2. Customer's installation piping or gas utilization equipment is hazardous, OR
 3. Conditions are such that gas service cannot be safely provided.
- 6.6.2 In refusing, AIC shall inform the customer in writing within 5 business days of the reason for refusal to provide gas service.

7.0 Installation

7.1 General

- 7.1.1 The *gas meter set* is defined as all pipe, regulator(s), fittings, and equipment from the outlet of meter valve to outlet connection of the meter or furthest downstream connection to an AIC installed fitting or equipment.
- 7.1.2 Gas meter sets and all associated equipment are the property of AIC. Only qualified AIC employees, contractors approved by AIC, or agents of AIC are authorized to install, relocate, modify, or maintain a meter set owned by AIC.

7.2 Installation Considerations

- 7.2.1 Meter sets shall be secure, upright, plumb and level in all directions to ensure meter accuracy and to prevent undue stress on the connecting piping and meter.
- 7.2.2 Where possible, effort should be made to install one of the following, downstream of the meter bar outlet, on new, replaced, relocated, or rebuilt gas meter sets:
1. A system bypass valve:
 - 1a. Angle Bypass Valve, 1" x1", (Stock Code 39 22 632), OR
 - 1b. Mueller Brisco Bypass Valve, 1" x 1", (Stock Code 39 01 140),
- or
2. A lock wing ball valve.
- 7.2.3 For new installation, the residential customer's fuel line should be:
1. Minimum of a 1-inch black-iron pipe passing through the structure wall or foundation (with appropriate sealed sleeve), or through the mobile home skirting; or
 2. CSST terminal bracket mounted to the outside wall.
- 7.2.4 The black-iron pipe should be connected to outlet of the meter bar or header. This provides additional support which reduces the stress on the meter set.

An exception to this would be in areas where installation of flex braided connectors is required or recommended to protect against subsurface subsidence or earthquakes.

- 7.2.5 The meter set should present a good appearance.
- 7.2.6 All gas meters shall be temperature compensated or have auxiliary and/or tertiary equipment that compensates for temperature.

- 7.3 All meters (diaphragm, rotary, and turbine) shall have a register or display on the meter or correcting device that displays the gas consumption in a definite and known proportion to the actual gas delivered to the customer. The register or display should be plainly visible for the customer to read. If requested, the Company will explain how to read the display and how the reading is used for billing.
- 7.4 Security
 - 7.4.1 All meters, auxiliary and tertiary equipment must have security seals installed or measures taken to secure the AIC equipment to deter unauthorized personnel from tampering with the equipment.
 - 7.4.2 All meter by-pass valves located upstream of the meter outlet shall be locked closed, when not in use, to deter unauthorized personnel from tampering with the valve.
 - 7.4.3 Regulators installed on fixed factor meter installations shall be security sealed in accordance with [METR 2.8, Subsection 6.4](#), under Pressure Factor Metering.
- 7.5 The meter connections and service piping should be inspected and cleaned before making any connections. Damaged threads, dirt, or other debris could damage the meter or cause a leak. Use AIC approved NO-OX-ID grease as shown in Table 3 on all threaded meter swivel connections.

Table 3: NO-OX-ID (No Oxide) Grease for Lubricating Gas Meter Swivels

Stock Code	Description
31 53 099	Grease - No Oxide: NO-OX-ID A-Special, 1# can
31 55 246	Grease - No Oxide: NO-OX-ID A-Special, 8 oz tube
31 59 733	Grease - No Oxide: NO-OX-ID Homac TL 101, 8 oz squeeze bottle

- 7.6 If a gas meter or regulator is located inside a building, then install a readily accessible shut-off valve outside the building.
- 7.7 Regulators located inside a building shall be vented to the outside with metallic pipe/tubing. See [Section 8.0](#)
- 7.8 Gas meter sets susceptible to flooding shall be addressed as follows:
 - 7.8.1 Regulator vent lines extended above expected high-water line, OR
 - 7.8.2 Regulator and meter installed above the expected high-water line, OR
 - 7.8.3 Designated as; need to be removed during flood conditions.

Gas meters will function when submerged but will need the AMI devices replaced following submergence.

- 7.9 All new residential meter sets shall have an insulating fitting installed upstream of meter at the time of construction.
- 7.10 Review all large-meter installations with Corrosion Control personnel (for that operating area) to determine proper insulation measures. See [CORR 2.1, Section 7.0](#), Insulating Points.

8.0 Regulator Vent Lines

- 8.1 Relief vent lines or relief stacks are to be made from metallic pipe/tubing.
- 8.2 All relief lines shall be the same diameter, or larger, than the regulator vent opening.
 - 8.2.1 Increase the vent diameter one pipe size every 10 feet to minimize flow restriction.
 - 1. The 10 feet may include up to 4 threaded fittings, (elbows, tees, etc.)
 - 2. If more than 4 threaded fittings are needed in the vent line, contact engineering for support.
 - 8.2.2 **Do Not** use street elbows.
 - 8.2.3 Keep the length of relief vent line as short as possible to minimize restriction and prevent adverse regulator operations.
 - 8.2.4 Contact Gas Engineering for relief vent lines greater than 45 feet in length.
- 8.3 Provide adequate support for vent line to prevent strain on the regulator case.
- 8.4 Locate the relief vent opening at least 12 inches above grade and ensure sufficient distance from sources of ignition and building openings.
- 8.5 The vent line shall be gas-tight, and termination shall be located such that:
 - 8.5.1 Gas can escape freely into the atmosphere,
 - 8.5.2 Water, ice, or snow cannot block the opening, and
 - 8.5.3 To weatherproof, provide a bug screen facing downward or a hinged rain cap.
 - 8.5.4 Vent lines connected to a regulator spring case or to the outlet side of a relief valve do **NOT** require pressure testing.

If a hinged rain cap is used, care should be taken when painting to not paint the cap shut or affect its operation.

- 8.6 Where relief venting may produce a large flow of gas in a public area, the vent termination should be installed above the pedestrian traffic.
- 8.7 Install a separate vent line for each regulator.

Multiple vent lines may be manifolded (using larger pipe) in accordance with accepted engineering practices to minimize backpressure in event of diaphragm failure.

- 8.8 Consult with Gas Engineering for any variance from the above, or questions concerning sizing.

9.0 Painting Meter Sets

- 9.1 All **uncoated** piping, fittings, and valves **should** be cleaned and coated with AIC approved paint at the time of installation **in accordance with CORR 1 Subsection 16.1 Painting Pipeline Facilities**.
- 9.2 Touch-up pre-painted meters and regulators with approved paint if needed.

9.3 Do not paint:

9.3.1 Regulator and relief valve vent openings.

9.3.2 Meter and regulator name plate badges.

9.3.3 Meter indexes.

9.3.4 Electronic Corrector or any other auxiliary equipment.

9.3.5 Remote Meter Reading Device or other tertiary equipment.

9.4 When completing routine work at the customer's premise, inspect the meter set condition, and complete any necessary re-painting or note it for scheduling future maintenance.

10.0 Scheduled Removal of Inactive Meters

10.1 Meters that have been inactive for 18 months or longer are identified each day by CSS and an OAS order with an MJ-87 (inactive Meter Removal) trouble code will be issued.

10.2 The Gas Supervisor should periodically review these orders and take action to ensure that the inactive meters are removed from service within 6 months.

10.3 When performing meter removals, gas field personnel should be alert to any indications that the structure is being demolished and report these structures to the Gas Supervisor for follow up action.

11.0 Removed Meters

11.1 Removed meters shall be returned to the shop in their removal condition.

11.2 Treat removed meters with the same care as a new meter since they must be tested for accuracy when returned to the meter shop. The follow-up test results can impact the customer's bill and any reports to the state commission. For handling and transporting meters, see [Subsection 5.2](#).

11.3 If a meter is removed from service and removed from the premise for any reason, it must be read and returned to the Gas Meter Shop for testing before the meter and/or any associated devices are adjusted, repaired, or replaced.

End of Instructions.

Operator Qualification (OQ) Required?

YES

0201: Visual Inspection of Installed Pipe and Components for Mechanical Damage

0301: Manually Opening and Closing Valves

0381: Spring Loaded Pressure Regulating Device-Inspection and Testing, Preventive and Corrective Maintenance

0591: Leak Test at Operating Pressure

0641: Visually Inspect Pipe and Components Prior to Installation

0711: Joining of Pipe - Compression Couplings

0721: Joining of Pipe - Threaded Joints

UNCONTROLLED IF PRINTED

0731: Joining of Pipe - Flange Assembly

0951: Installation of Pipe Above Ground

0961: Above Ground Supports and Anchors - Inspection, Preventive and Corrective Maintenance

1161: Installation of Meters and Regulators - Residential and Small Commercial

1171: Installing Meters - Large Commercial and Industrial

1181: Installing and Maintaining Pressure Regulating, Limiting, and Relief Device - Large Commercial & Industrial

1191: Maintenance of Service Valves Upstream of Meter

1201: Temporary Isolation of Service Lines and Service Discontinuance

A001: Service Reconnect

A003: Emergency Response

Appendices

NONE.

Attachments

NONE.

Compliance Requirements

49 CFR Part 192 Subpart H - Customer Meters, Service Regulators, and Service Lines

Illinois Commerce Commission (ICC) Title 83: Public Utilities, Part 501 Standards of Service for Gas Utilities and Alternative Gas Suppliers, specifically Subpart B: Natural Gas Measurement Requirements, available online [here](#).

Reference Documents

[CORR 2.1 Corrosion Control: Cathodic Protection Design](#)

[CORR 2.3 Corrosion Control: Coatings - Approved Paint Specification](#)

[METR 2.5 Metering: Gas Meter Bypass](#)

[METR 2.8 Metering: Pressure Factor Metering](#)

[METR 3.1 Metering: Meter Sizing](#)

[METR 3.2 Metering: Regulator Sizing](#)

[METR 4 Metering: Forms and Reference Materials](#)

[SERV 1 Service Line Installation: Requirements](#)

Document Rescission

METR 1 Metering: Requirements, October 1, 2022

Revision Notes

Location of Changes	Summary of Changes
---------------------	--------------------

<p>Subsection 9.1 Painting Meter Set</p>	<p>Revised: All uncoated piping, fittings, and valves should be cleaned and coated with AIC approved paint at the time of installation in accordance with CORR 1 Subsection16.1.</p> <p>Removed regulators and meters. These should already be painted when installed. Touch-up of regulators and meters is covered in Subsection 9.2</p>
--	---

METERING

April 1, 2023

METR 2.1 Replacement and Retirement

1.0 Purpose

This document prescribes the considerations for proper replacement and retirement of Ameren Illinois (AIC) gas meters to ensure safe and accurate measurement of natural gas under varying pressure conditions. This includes timely upgrading of equipment consistent with industry practice and gas measuring technology. Further, it addresses various replacement of meters and provides the available avenues for retiring gas meters in MMS.

2.0 Scope

This document addresses the following:

[3.0 Target Audience](#)[4.0 Obsolete Meters](#)[5.0 Meter Retirements](#)[6.0 Meter Exchanges](#)[7.0 Large-Volume Diaphragm Meter Replacement](#)[8.0 Meters Removed from Field](#)[9.0 Obstructions at Worksite](#)[10.0 Painting Meter Set](#)[11.0 Reporting](#)

Appendices

[Appendix A - Postcard Contact](#)[Appendix B - Letter Contact](#)**3.0 Target Audience**

- Gas Engineering
- Gas Supervisors
- Gas Field Personnel
- Gas Technical Services (GTS) Supervisor
- Gas Meter Supervisor

4.0 Obsolete Meters**4.1 General**

4.1.1 AIC has a wide variety of gas meters by various manufacturers, with different designs and case material, in service across the various operating territory. While most meters are mechanically reliable and accurate, some have been identified by current standards as obsolete.

4.1.2 This section identifies the obsolete meters that should be considered for replacement.

4.2 Replacing Obsolete Meters

UNCONTROLLED IF PRINTED

- 4.2.1 Residential gas meters that are considered obsolete should be exchanged, when possible, in conjunction with routine service work.
- 4.2.2 Exchanging these meters during routine service work will proactively reduce the number of problematic and/or obsolete meters while distributing the replacement cost over time.
- 4.2.3 This practice should reduce repeat visits, customer outages, and improve customer satisfaction.
- 4.2.4 Large diaphragm gas meters (EMCO, Sprague, and "B" Series) that are considered obsolete should be identified and replaced when resources are available based upon Region workload.
- 4.2.5 Gas meters shall not be replaced during routine service work solely based on age.
- 4.2.6 Table 1 identifies all those gas meters that are considered obsolete:

Table 1: Meters Considered Obsolete

METER TYPE	METER CODE
Diaphragm Meters	
Cast iron meters	Not Applicable
Meter/regulator combination units	02200 - 02240
American/Metric "B" series meters	Not Applicable
American 5B225 meters	01820, 01821, 01828, 01829, 91820 & 91821
Emco meters	01300 - 01370
Lancaster meters	01750, 01760
Rockwell 150 & RX meters	01500; RX per badge ID
Rockwell R175, R200 & R250 meters	01510, 01520, 01521, & 01530
Rockwell 310, 315 & 415 meters	01540; 01640, 01641, 01648, 01649 91640 & 91641; 01550, 01551, 01558, 01559, 91550 & 91551
Sprague 1A meters	01280
Sprague 175 & 240 meters with square index box	Not Applicable
Sprague Metris 250 meters	01270
Sprague 305 meters	01220
Sprague 400 large body meters (MCO1231)	(See above std. body)
Sprague 675 & 1000 meters	01240, 01241, 01248, 01249, 91240 & 91241; 01250, 01251, 01258, 01259, 91250 & 91251
Superior meters	01700 - 01720
Any meters that have appearance of being physically damaged by corrosive gases, abusive handling, fire, explosion, or over-pressurized	Not Applicable

Rotary Meters	
Roots/Connersville meters (old-style), sizes 2.5 x 7 through 28 x 42	Not Applicable
Roots meters, sizes 3M, 5M, 7M, 11M, and 16M with cast iron impellers	Not Applicable
American CVM meters	Not Applicable

5.0 Meter Retirements

5.1 Criteria for Retiring

5.1.1 Any gas meter that meets one or more of the following criteria should be retired once the meter has been "in-tested" and test results are recorded in MMS.

1. Small diaphragm meter (425 cfh or less) that:
 - 1 a. Is 30 years or older.
 - 1 b. Will require more than a "Class B" repair.
2. Damaged by exposure to corrosive gases, abusive handling, over-pressurization, fire, explosion, or is physically damaged.
3. Found with an internal leak.
4. Estimated repair cost exceeds 80% of a new meter (at similar capacity).

5.1.2 Turbine meters, orifice meters, and all other meters not covered above, may be retired at discretion of the Gas Meter Supervisor.

5.2 Procedure for Retiring Meters

5.2.1 All meters shall be retired in MMS.

5.2.2 A meter can be retired in the system by using **any one** of the following methods:

1. A report listing the gas meter retirements is passed to the Asset Management System (AMS) so that the meters can be removed from gas plant records.
2. A retirement exception (error) report is processed through Customer Service System (CSS) and forwarded to IL Metering and Projects for review and corrections when required.
 - 2 a. Under the system tab "Meter Data" - "Meter Information Update," click on the "Retire" button listed across the top.
 - 2 b. At the MMS "Receive Station."
 - 2 c. At the PC Prover test stand.
 - 2 d. At the MMS "Repair Station."

6.0 Meter Exchanges

6.1 General

6.1.1 Gas meters must be tested in accordance with Illinois Commerce Commission (ICC) regulations.

6.1.2 IL Metering and Projects is responsible for administering the various meter testing programs and will provide lists of meters to be tested to the various operating groups.

6.1.3 This procedure explains the testing programs and provides guidance to operating groups for scheduling and removing gas meters from service when they are due for test.

6.2 Meter Management System (MMS)

6.2.1 MMS is the computer system that provides overall support for AIC gas (and electric) meter testing activities.

6.2.2 MMS contains functionality to select meters for the sample, periodic, and mileage testing programs and produces the various lists, change orders, and other documents required to administer these programs.

6.2.3 MMS collects test information directly from various gas meter testing sites and transfers data to CSS.

6.3 Periodic Testing Program

6.3.1 *Periodic Testing* is a term applied to ICC's original rules for testing diaphragm gas meters on a fixed 10-year interval; thus, may not remain in service more than 120 months since the last test date (unless included in an approved sample testing program). This means that size 675 gas meters and larger shall be tested for accuracy at intervals not exceeding 120 months. And, this applies to any small meters that are not included in the sample testing program.

6.3.2 Periodic testing also includes a 60-month test requirement for all rotary and turbine meters. See [Paragraph 6.3.5](#).

6.3.3 Lists and Outage Analysis System (OAS) meter exchange and field test orders for meters due for periodic test may be distributed, typically in December. The list will contain the last test date for each meter listed.

6.3.4 The Gas Supervisor is responsible to ensure that all diaphragm meters are removed prior to their test due date.

6.3.5 The Gas Technical Services (GTS) Supervisor is responsible for ensuring rotary meter and turbine meter tests are performed prior to the due date from their last test date as follows:

1. Rotary meter differential tests performed at least *every 60 months*.
2. Turbine meter spin tests performed at least *every 12 months*.
3. Turbine accuracy tests performed at least *every 60 months*.

6.4 Mileage Testing Program

6.4.1 This testing program operates on the premise that measurement accuracy is a function of diaphragm cycles rather than years of service. However, it cannot extend the time limits. When considered, it is typically applied to larger size diaphragm meters.

The mileage testing program is not currently used at AIC. Therefore, details are not presented.

6.5 Sample Testing Program

6.5.1 AIC will provide notification to the ICC Staff of the intention to use "Sample testing." Since most gas meters maintain their accuracy for periods of 30 years or

longer, sample testing programs result in significant cost savings through reductions in the number of meters exchanged for test.

- 6.5.2 Meters subject to sample testing are assigned to meter lots as determined by manufacturer, size, and year installed. AIC meters are combined for sample testing purposes. The lots become eligible for sampling in their 9th year of service and are sampled each year thereafter until the lot fails, or in the alternative, all meters in the lot have been removed through normal attrition and sampling.
- 6.5.3 The sample test plan applicable to AIC is known as "Double Sampling" plan. Under such plan, an initial sample is selected and tested. Based upon the results of the first sample, the lot is either accepted, rejected, or identified as inconclusive. If the first results fall into the inconclusive category, a second sample is taken. Upon analysis of the second sample test results, the lot is either accepted or rejected.
- 6.5.4 Lists and OAS exchange orders for meters due for test under the first sample will typically be distributed in December. IL Metering and Projects will establish a due date for completion, typically by end of May. The advantages of this schedule are:
1. Allows work to be completed prior to construction season.
 2. Cooler temperatures facilitate operational checks of heating equipment upon completion of meter exchange.
 3. Early completion of the first sample allows time for second samples that might be required, or for completing any rejected lots.

6.6 Scheduling Meter Exchanges

- 6.6.1 All residential "sample meter" exchanges will be done by appointment unless otherwise approved by Gas Supervisor. Make initial contact with customers by phone, postcard, or letter at discretion of the Gas Supervisor. See [Appendix A](#) for a sample message. Avoid "Cold Calls" that result in wasted time and adverse customer reaction. To extent possible, schedule all meter exchanges during normal working hours to minimize costs and avoid overtime.

If meter set is equipped with a bypass valve for the use of a portable CNG tank, customer notification and/or presence is not necessary for the meter change.

- 6.6.2 Customers who fail to respond to an appointment request will receive a follow-up letter, which progressively stresses the urgency of the required work. Allow a minimum of one week for customer to respond before sending a third (final) letter. In event that the third letter is required, it will be sent via certified mail or CSS generated so that the final contact attempt is documented. See [Appendix B](#) for sample letter (also available in CSS).

6.7 Requesting Substitute Samples

- 6.7.1 From time to time, situations exist that make it extremely difficult to exchange a meter that is due for sample testing. In these circumstances, the Gas Supervisor may request that a test meter requirement be waived and that a substitute meter be selected. When a substitute meter is requested, it will be selected at random

from entire lot. This may result in work being shifted from one location to another. The Gas Supervisor should use such requests as a last resort.

6.7.2 No substitutes are allowed for meters identified for periodic testing.

6.8 Customer Satisfaction

6.8.1 Gas meter exchanges may require significant interaction with customers. As such, meter exchanges provide an opportunity to influence customer satisfaction, either positively or negatively, depending upon AIC performance.

6.8.2 To avoid dissatisfied customers, follow these practices:

1. Give customers advance notice by telephone, postcard, or letter that a meter test is due. An appointment will be made to do the meter exchange.
2. Make every effort to keep scheduled appointments. If an emergency arises that prevents honoring an appointment, then contact the customer and provide an explanation and apology.
3. Exercise care when entering a customer's home to avoid tracking in outside elements.
4. Never smoke in a customer's home.
5. Wipe off soap solution from exposed piping and floors.
6. Remove pilot lighting aids and related items from the home.
7. Always treat customers with courtesy and respect.

6.9 Malfunctioning Thermocouples and Control Valves

6.9.1 Occasionally, the pilot light on a gas appliance that has been shut off for meter exchange cannot be re-lit due to a defective thermocouple and/or control valve. In such instances, customers often claim that the equipment was damaged by gas field personnel since the appliance was working before the meter exchange. Rather than dispute such claims, the Gas Supervisor may authorize replacement of thermocouples and/or control valves at company expense when failure is identified at the time meter is exchanged.

6.9.2 This policy does not apply to:

1. Equipment that was not in service immediately prior to meter exchange, or
2. Any major repairs such as cracked heat exchangers, rusted or improper venting, defective piping, or similar items.

7.0 Large-Volume Diaphragm Meter Replacement

7.1 General

7.1.1 Large diaphragm gas meters are typically considered to be 800 cfh and larger.

7.1.2 The meter replacement could be for a like-size "Periodic" exchange or to rebuild/resize the meter set.

7.1.3 These procedures are established to perform safe and efficient meter replacement with minimal interruption to the customer's gas service.

7.1.4 Replacing this class of meter might require assistance of a vehicle equipped with crane.

7.1.5 The job assignment and meters/materials needed should be obtained from the OAS order on the assigned electronic device.

UNCONTROLLED IF PRINTED

7.2 Inspecting Customer Piping and Appliances

7.2.1 Gas field personnel shall look for code violations and/or hazardous conditions in accordance with the following:

1. NFPA 54, National Fuel Gas Code,
2. HUD Title 24 Building Code for manufactured housing, or
3. Applicable local codes.

7.2.2 If hazardous conditions exist and remediation work exceeds the normal scope of repair work performed by gas field personnel, then complete a Notice of Code Violation or a Hazardous Condition Warning tag and document on the OAS 6H screen.

7.3 Meter and Regulator Inspection

7.3.1 Before touching the meter set, check riser, meter, and customer piping for possibility of AC voltage with a "volt stick". If voltage is detected (i.e., volt-stick alarms), contact the Gas Supervisor to initiate an investigation of the voltage source prior to performing any additional work on energized section. See [METR 2.2, Subsection 7.2](#), AC Voltage on Meter Set.



Figure 1: Image of Volt Stick

7.3.2 Verify meter number.

7.3.3 Record the removed meter reading.

7.3.4 Check condition of the meter set.

7.3.5 Check regulator outlet pressure and lockup pressure:

1. On all "New-Service Connects."
2. Whenever a meter is exchanged or installed.
3. Whenever a meter valve or service regulator is changed.

7.4 Meter Header Inspection

7.4.1 Perform a "Meter Header Inspection" in accordance with [METR 2.2](#).

7.4.2 When weather conditions or other factors prevent any of the above inspections and maintenance work from being completed, gas field personnel shall document the condition and report to the Gas Supervisor for follow-up.

7.5 Meters Being Transported or Moved

7.5.1 Anytime a meter is moved, exercise care to prevent possible damage to meter or its ability to accurately measure gas consumption. Always handle meters carefully to avoid hitting, dropping, bumping, or any other disturbance that may negatively impact the meter operation. See [METR 1, Section 5.0](#), Care and Handling.

7.6 Exchanging the Meter

- 7.6.1 When exchanging the meter, use a backup wrench to prevent altering other piping or devices connected to meter.
- 7.6.2 Ensure that the bypass, where applicable, has been properly operated and that the load has been transferred to the bypass run.
- 7.6.3 For bypass operation, turn off the meter outlet valve first while monitoring an appropriate pressure gauge to ensure that gas supply to customer is not interrupted.
- 7.6.4 When a bypass operation is not used, closing the outlet valve will also eliminate any release of gas contained in the customer fuel line. The inlet valve to the meter can then be shut off to isolate meter.
- 7.6.5 If necessary, tap the meter nuts/unions with a hammer after applying penetrating oil to loosen rusted connections. Once the meter nuts/unions have been loosened, then remove the existing meter and set aside, taking care not to damage meter.
- 7.6.6 If the meter has inlet/outlet nipples, remove them and install them on the new meter. Clean and grease/dope old fittings to establish a gas tight seal to meter and connecting union.
- 7.6.7 Securely connect the replacement meter to inlet piping. Hand tighten the outlet meter nut/union, or flange, in order to purge air through meter to the outlet side once meter inlet valve is turned on. Once a slight natural gas odor is recognized, securely tighten the outlet connection. The meter, header, riser, and any other attachments that might have been altered shall be fully checked for leaks.
- 7.6.8 When transferring the load from, or to the meter, it is necessary to follow established bypass procedures. See [METR 2.5](#).
- 7.6.9 Perform an inspection of the customer's fuel line and appliances *only* if there is an interruption of gas service or customer complaint during the meter replacement.

7.7 Changing Correcting Devices

- 7.7.1 When doing a meter replacement, a correcting device exchange may be required.
 - 1. If the new meter does not have a correcting device, existing correcting device may be transferred to the new meter. Inspect the transferred correcting device to verify proper operations within 60 days following the meter exchange.
 - 2. If new meter has a correcting device on it, then input the required data to the OAS order and include on Gas Meter Data Sheet, [METR 2.10](#).
 - 3. Where the correcting device on existing meter is different than index on new meter (lbs. to in. or in. to lbs.), then the proper correcting device shall be provided for the new meter.
- 7.7.2 Meters with automated reading devices installed must be exchanged as a combined single unit. The AMI device must stay with the meter it was assigned to and is identified by that meter number.

8.0 Meters Removed from Field

- 8.1 Keep new or replacement meters separate from removed meters being returned from the field.

- 8.2 Ensure that removed meters have dirt or debris brushed off and that inlet and outlet ports have proper caps or plugs installed to keep out water, dirt, or debris. If no caps/plugs available, then use other protection (e.g., duct tape over the inlet/outlet connections) to prevent foreign material from entering meter.
- 8.3 Once meters are returned to the Service Center, handle them with care and place in appropriate location at the Service Center pending transfer to the gas meter shop.

9.0 Obstructions at Worksite

- 9.1 Obstructions at the worksite that interfere with performing meter replacement should be handled by the employee if they are minor and can be resolved reasonably.
- 9.2 Any significant obstructions (e.g., landscaping, large branches, material, drainage issues, vehicles, equipment) that may complicate the routine meter replacement shall be brought to the customer's attention for resolution; supervision is to be notified concerning the job. The Gas Supervisor or GTS Supervisor shall follow-up with the customer concerning removal of obstruction.
- 9.3 Evaluate the situation and advise the supervisor of observed alternatives to the obstruction issue impacting meter replacement. Enter information electronically for future reference.

10.0 Painting Meter Set

- 10.1 If above ground piping needs painted, it shall be done in accordance with [METR 1 Section 9.0 Painting Meter Set](#).

11.0 Reporting

- 11.1 Complete appropriate OAS orders.
- 11.2 Complete Gas Meter Data Sheet, as applicable, and distribute. See [METR 2.10](#).

End of Instructions.

Operator Qualification (OQ) Required?

YES

0201: Visual Inspection of Installed Pipe and Components for Mechanical Damage

0301: Manually Opening and Closing Valves

0641: Visually Inspect Pipe and Components Prior to Installation

0721: Joining of Pipe - Threaded Joints

0731: Joining of Pipe - Flange Assembly

0961: Above Ground Supports and Anchors-Inspection, Preventive and Corrective Maintenance

1161: Installation of Meters and Regulators - Residential and Small Commercial

1171: Installing Meters - Large Commercial and Industrial

1181: Installing and Maintaining Pressure Regulating, Limiting, and Relief Device - Large Commercial & Industrial

1191: Maintenance of Service Valves Upstream of Meter

UNCONTROLLED IF PRINTED

1201: Temporary Isolation of Service Lines and Service Discontinuance

A001: Service Reconnect

A003: Emergency Response

Appendices

[Appendix A - Postcard Contact](#)

[Appendix B - Letter Contact](#)

Attachments

NONE.

Compliance Requirements

Illinois Commerce Commission (ICC), TITLE 83, Chapter I, Subchapter d, Part 501, Subpart B: Natural Gas Measurement Requirements, available online [here](#).

Reference Documents

[CORR 1 Corrosion: Requirements](#)

[METR 1 Metering: Requirements](#)

[METR 2.2 Metering: Meter Inspection and Testing - Field](#)

[METR 2.3 Metering: Meter Inspection and Testing - Shop](#)

[METR 2.5 Metering: Gas Meter Bypass](#)

[METR 2.10 Metering: Gas Meter Data Sheet](#)

NFPA 54, National Fuel Gas Code

HUD Title 24 Building Code for manufactured housing

(See ICC compliance link above)

Document Rescission

METR 2.1 Metering: Replacement and Retirement, October 1, 2020.

Revision Notes

Location of Changes	Summary of Changes
Section 10.0 – Painting Meter Set	Revised 10.1 – If above grade piping, fittings or valves needs painted it shall be done in accordance with METR 1 Subsection 9.1 Painting Meter Sets. Removed 10.2

Appendix A - Postcard Contact

Initial Message 1: Contact by postcard, or phone,

AND, if necessary

Contact Effort 2: Use postcard if no response to initial contact.

CUSTOMER ACTION REQUIRED

[Or]

2nd NOTICE - CUSTOMER ACTION REQUIRED

Dear Valued Customer,

Your gas meter has been identified as due for test to comply with the Illinois Commerce Commission regulations. The meter must be replaced to be tested. For gas service to resume after replacing the meter, Ameren Illinois Utilities offer you a choice of two options:

1. Schedule an appointment to meet a representative at your residence to change the gas meter, inspect your appliances, and relight the pilot lights on your gas appliances. *(No charge for this service.)*
2. Identify a day to have the meter changed and your continuity of pilot service **left off**. This option allows you to relight your appliances at your convenience and you do not have to be present when a representative changes the meter. For appliances with electronic ignition, service would resume.

We ask that you call our office at xxx-xxx-xxxx during the hours of x:xx a.m. and x:xx p.m. to select the option you prefer for replacing your gas meter.

Appendix B - Final Letter Contact

Step 3: Letter used if previous contacts are ignored; send certified mail or use CSS generated letter so that third effort is documented.



CUSTOMER NAME

ADDRESS

CITY ST 99999

FINAL REQUEST:

METER APPOINTMENT REQUIRED

Service Address:	ADDRESS	Account Number	99999-99999
	CITY ST 99999	Meter Number	99999999

Dear Customer,

UNCONTROLLED IF PRINTED

This is our third attempt to contact you regarding need to test your natural gas meter. As explained in previous notices, your gas meter is due for testing, as required by the Illinois Commerce Commission.

Since the gas meter must be removed from service for testing, a short interruption of your gas service will be required while we install a replacement meter. Following the meter change, we will need access to your gas appliances to relight your appliances and restore gas service.

We had hoped to perform the meter change at a time convenient to you, so we could minimize the impact on your gas service. Unfortunately, we have not received a response to our previous requests for you to contact us regarding appointment.

As a result, our only remaining option is to change the meter and leave the gas supply off following the work. This work is currently scheduled to be performed on or after 9/9/99, unless you request a different appointment before that date. Please note that if we are called back to your home to relight appliances later, service charges may apply.

We once again urge you to call us to set up an appointment convenient to you so you can avoid an extended interruption of your gas service and possible service charges.

Thank you for your prompt attention to this matter.

Sincerely,

Customer Service: 1.800.755.5000

End of Appendices

METERING

May 15, 2022

METR 2.2 Meter Inspection and Testing - Field

1.0 Purpose

This procedure identifies requirements for various testing of Ameren Illinois (AIC) gas meters and testing equipment to meet or exceed accuracy limits and schedules established by the Illinois Commerce Commission (ICC). It includes the various criteria and guidelines governing the inspection and testing programs applicable to field activities.

2.0 Scope

This document addresses the following:

[3.0 Target Audience](#)

[4.0 Sample Testing](#)

[5.0 Periodic Testing](#)

[6.0 Customer Requested Test](#)

[7.0 Meter Header Inspection](#)

[8.0 Records and Retention](#)

Appendices

[Appendix A - AC Voltage Potential at Meter Set](#)

[Appendix B - Regulator Related Pictures](#)

3.0 Target Audience

- Gas Engineering
- Gas Supervisors
- Gas Field Personnel
- Gas Technical Services (GTS) Supervisor
- Gas Meter Supervisor
- Gas Meter Shop Foreman
- IL Metering and Projects Supervisor

4.0 Sample Testing

4.1 Regulatory Requirements

- 4.1.1 Illinois Administrative Code Part 501 allows for sample testing of all new and in-service diaphragm gas meters.
- 4.1.2 AIC must notify the ICC of intention to use "sample" testing.
- 4.1.3 The sample testing plan results shall be filed as part of the annual Form 21 report. IL Metering and Projects will provide the Form 21 data to Plant Account for formal filing of report.

4.2 Sampling Criteria

- 4.2.1 AIC practices the Double Sampling Plan for normal inspection as based on ANSI/ASQ Z1.4 2008, with General Inspection Level II at AQL of 6.5 using "Sampling Procedures and Tables for Inspection by Attributes." Sample lots are evalu-

UNCONTROLLED IF PRINTED

ated using the Kolmogorov-Smirnov (K-S) Test method with a (K-S) value of 95%.

1. Initial sample of meters is selected, removed from service, and tested. Based upon the results of the first sample, the lot is accepted, rejected, or identified as requiring re-sampling.
2. When re-sampling is required, a second sample lot (equal in size to the initial sample) is randomly selected. Those meters are removed from service and tested. The re-sampled lot is accepted or rejected based upon cumulative results of the first and second samples.
3. For sample testing, a meter is defined as out of tolerance when the average accuracy of the check rate and capacity rate tests is less than 97.0% OR greater than 103.0%.

4.3 Sample Lots

4.3.1 In the Meter Management System (MMS), assign gas meters (for sample testing) to meter lots as determined by:

1. Manufacturer,
2. Meter size, AND
3. Installation year.

4.3.2 Combine meters for sample testing purpose.

4.3.3 Sample the meter lots in their 9th year of service, and each year thereafter until:

1. The lot fails, OR
2. All meters in the lot have been removed through normal attrition and sampling.

4.3.4 IL Metering and Projects will evaluate small lots to determine if they should be scheduled for 100% change out.

4.3.5 There is no maximum in-service life for a gas meter in Illinois subject to Sample testing.

4.4 Annual Scheduling

4.4.1 Prior to scheduling, exclude any rejected lots from the current and previous years.

4.4.2 Following completion of the current year's Sample testing program, IL Metering and Projects will initiate the annual random sample selection process in MMS for the sample testing program that will be completed in the following year.

4.4.3 Customer lists and OAS exchange orders for meters due for test under 1st-round sampling will typically be distributed in *December*. Normal deadline for 1st-round exchanges will be *May 31*.

4.4.4 Following evaluation of 1st-round samples, if required, IL Metering and Projects, will initiate:

1. The MMS process for random selection of the 2nd sample gas meters, and
2. Customer lists and OAS exchange orders for 2nd sample meters will be generated and distributed.

3. Deadline for 2nd round meter exchanges will be determined by:

3 a. 1st-round completion of sample evaluations, and

3 b. Volume of the required 2nd-sample meter exchanges.

4.4.5 All required sample tests must be completed by end of the calendar year in which the tests are due for completion.

4.5 Requesting Substitute Sample Meters

4.5.1 It may be necessary to randomly select substitute samples to replace sample meters that were difficult to exchange or unable to be tested (e.g., lost, stolen, damaged).

4.5.2 Substitute samples will be chosen only when missing sample meter test results prevent the accept/resample/reject decision from being made.

4.5.3 When necessary, IL Metering and Projects will randomly select substitute samples from the lots that have missing sample meter test results.

4.6 Rejected Sample Lots

4.6.1 ICC Part 501 requires 100% removal of any remaining meters from a failed lot within 24 months after the current year's sampling. This is requirement for the sample testing process.

4.6.2 IL Metering and Projects will initiate the generation of customer lists and OAS exchange orders for all failed/rejected meters.

4.7 Sample Meter Test Results

4.7.1 Post the sample meter test results to MMS through the following methods:

1. *Sonic-Nozzle Provers*: Upload through the electronic interface to MMS.

2. *Manual Entry*: IL Metering and Projects may manually enter results into MMS for individual sample meters.

3. *Contractor Files*: IL Metering and Projects may receive results from contractor and upload to MMS by the batch upload process.

5.0 Periodic Testing

5.1 General

5.1.1 The term periodic testing applies to the original Illinois Commerce Commission rules for testing diaphragm gas meters on a 10-year interval.

5.1.2 This procedure identifies the requirements for periodic testing of gas meters not included in the AIC sample testing program.

5.1.3 Retain all required documentation such that it is readily available upon ICC request.

5.1.4 For testing of rotary and ultrasonic meters:

1. Rotary meters, see [METR 2.4, Section 5.0](#).

2. Ultrasonic meters, see [METR 2.4, Section 7.0](#).

5.2 Periodic Testing of Diaphragm Meters

5.2.1 Test all diaphragm gas meters that are not included in an approved sample testing program every *120 months* based upon the date of the last test.

UNCONTROLLED IF PRINTED

5.2.2 Typically, 800 scfh diaphragm meters and larger are to be tested according to the 10-year periodic schedule since they are not currently included in AIC's sample testing program.

5.3 Periodic Test Schedule

5.3.1 IL Metering and Projects will initiate the Periodic Meter Selection process each year - identifying meters in MMS as due for testing during the following year. Customer lists, OAS exchange, and field test orders will be processed and distributed. The list will contain the last test date for each meter listed.

5.3.2 Gas Supervisor is responsible to ensure that each diaphragm meter listed is removed from service prior to the test due date.

5.3.3 GTS Supervisor is responsible to ensure that the following actions are completed by the due date:

1. All listed rotary meters are tested.
2. All listed turbine meters are spin tested and/or accuracy tested.

5.4 Periodic Meter Test Results

5.4.1 Document all periodic meter test results in MMS (or as a paper record) through the following methods:

1. *OAS Entry*: Upload through the electronic interface to MMS.
2. *Manual Entry*: IL Metering and Projects may manually enter results into MMS for individual periodic meters.
3. *Contractor Files*: IL Metering and Projects may receive results from contractor and upload to MMS by the batch upload process.

6.0 Customer Requested Test

6.1 General

6.1.1 This procedure outlines the process to ensure proper notification of gas meter accuracy test results to all parties or their stated representatives.

6.1.2 *Customer Requested Test* is defined as any gas meter removed from service due to a customer complaint and request for an accuracy test.

6.1.3 The same requirements within this procedure apply to accuracy tests requested by an alternative gas supplier (AGS) or those requests received to have a Commission Staff member referee an accuracy test.

6.1.4 For a Commission Referee Test, the customer shall pay for the accuracy test based upon Schedule of Fees in ICC Code Part 501. Fee shall be refunded to the customer if gas meter is found to over-register gas by more than 2%.

6.2 AIC Requirements/Practices

6.2.1 Complete the accuracy test for a Customer Requested Test within *45 days* after receiving request, unless the customer agrees to a later time.

AIC has set a KPI goal to complete the test within *30 days*.

6.2.2 Perform accuracy test of the meter at no cost to the customer providing:

1. Meter has not been accuracy tested within *12 months* prior to the request. Otherwise, see [Paragraph 6.3.5](#).
2. Meter is rated below 16,000 cfh and does not require physical removal to complete test. Otherwise, see [Paragraph 6.3.6](#).
3. The requested test is not a Commission Referee Test.

6.2.3 All gas meters will be handled in accordance with the procedures contained in [METR 1, Section 5.0](#), Care and Handling.

6.3 Requested Meter Test

6.3.1 When receiving a request for a Customer Requested Test, the CSR (Customer Service Representative) initiates a Change Meter Order (CMO) with a "Reason for Order" of "Customer Request" to the local office. A WFM (Workflow Manager) shall be generated to the O.C. to notify the Gas Supervisor that a Customer Requested Test meter exchange is required.

1. Initiating the "Customer Requested Test" order will also generate a "Hold" for the gas meter in MMS. The "Hold" has comments in MMS to notify the meter shop co-worker "Receiving" the gas meter that special handling is required to complete the customer requested test.

6.3.2 The local Gas Supervisor will have the gas meter exchanged and tagged as "Customer Requested Test" with the actual reason for change, (Customer complaint) marked on the order. Arrange to transport the meter(s) to the gas meter shop.

6.3.3 Deliver the meter tagged "Customer Requested Test" to the gas meter shop within 5 business days following its removal from service.

6.3.4 Upon receiving meter, the gas meter shop foreman notifies the meter shop administrative clerk who will do the following:

1. Verify the request date to determine a valid test date.
2. Call the customer to schedule the test and see if the customer wants to witness the test. If the customer cannot be reached, the administrative clerk determines a valid date.
3. Notifies the foreman of the test date.

6.3.5 If the meter has been accuracy tested within the previous 12 months, advise the customer that charges may be pending for the additional accuracy testing per Section 501.260, 501.270, and 501.280 of the Illinois Administrative Code.

6.3.6 For meters rated at or above 16,000 cfh that require physical removal to perform test, the customer shall pay the costs associated with a Customer Requested Test.

1. The test charge shall not exceed \$10,000 for tests completed at AIC facility or \$25,000 for tests that require the meter to be sent to a non-affiliated third-party.
2. An itemized written cost statement for the requested test, the customer's agreement to pay the stated cost, and payment shall be received before any action is taken to remove the meter.
3. If meter is found to over-register by more than 2%, customer will be fully reimbursed those fees charged for the test.

UNCONTROLLED IF PRINTED

- 6.3.7 Schedule meter accuracy test within 15 days of receiving the Customer Requested Test gas meter in MMS at the gas meter shop. This time is required to schedule the test for a date, time and location for customer to witness the accuracy test, if desired.
1. Schedule test in the gas meter shop, unless the meter must be shipped to a third-party facility (for testing capacity reasons).
 2. Complete test as soon as possible if customer does not desire to witness test.
- 6.3.8 The gas meter shop foreman is responsible to complete the meter accuracy test at the scheduled date, time, and location with or without the customer presence. Should customer (or their designated representative) choose to witness the accuracy test, a gas meter supervisor or gas engineer should attend.
- 6.3.9 Record the accuracy test results as a "Customer Complaint" in MMS.
- 6.3.10 Provide a written summary of the accuracy test results to customer within *5 business days* of completing test.
- 6.3.11 Store meter temporarily to ensure that all parties have been notified of the accuracy test results.
1. Store for 90 days if there is no follow-up legal action pending.
 2. Store in excess of 90 days if there are ongoing or anticipated legal actions pending due to dispute with meter accuracy.
- 6.3.12 Gas meter subject to a Commission Referee Test for accuracy:
1. Meter shall not be disturbed upon receipt of notice unless in the presents of ICC Staff member or with authorization by Staff/customer. Document the authorization, including the name of person giving the authorization and date/time of the authorization.
 2. AIC co-worker or ICC Staff member shall transport a gas meter subject to Commission Referee Test to the testing facility and secure the meter to prevent potential tampering or disturbance from its in-service condition until the test begins.

7.0 Meter Header Inspection

7.1 General

- 7.1.1 This procedure describes inspections and maintenance that should be done at the meter set when performing any work on it.
- 7.1.2 This also addresses the potential hazards and precautions associated with the possibility of induced AC voltage on the meter set. See [Appendix A](#) for expanded discussion on AC voltage potential, especially with many older homes.

7.2 AC Voltage on Meter Set

- 7.2.1 An AC voltage risk occurs at the connection with customer piping due to improper grounding.
- 7.2.2 Before performing any work on a gas meter set, use a voltage stick to check for AC voltage on the listed locations. The AIC stock coded voltage tester (volt stick), 60 05 635, is a non-contact voltage tester, with an infrared thermometer, that will detect voltages from 12 VAC to 1000 VAC.
1. Service riser.

UNCONTROLLED IF PRINTED

2. Meter.
3. Customer fuel line.



Figure 1: Image of Volt Stick Klein Model NCVT-4IR

If voltage is detected, contact the Dispatcher to request an Electric person to measure voltage.

Volt stick models NCVT-3 or NCVT-3P can continue to be used, but take care to select the lower voltage when using a volt stick with voltage ranges.

7.3 AC Voltage Action Table

- 7.3.1 Do not work on the meter set if the measured voltage is 15 volts or higher until the voltage source has been eliminated. See [Table 1](#).

National Society of Corrosion Engineers (NACE) has a Recommended Practice RP 0177-2000 that defines a shock hazard as 15 volts AC.

Table 1: Voltage Action

	Voltage on Riser	Voltage on Customer Piping	Voltage on Both, Riser and Customer Piping
Volt Stick "Alarms"	Contact Dispatcher, Request Electric Service person to measure voltage. (See Paragraph 7.2.2.)	Contact Dispatcher, Request Electric Service person to measure voltage.	Contact Dispatcher, Request Electric Service person to measure voltage.
Measured Voltage at Less than 15 volts	<ul style="list-style-type: none"> • Not a Hazardous Condition. • No Corrective Action Required. 	<ul style="list-style-type: none"> • Not a Hazardous Condition. • No Corrective Action Required. 	<ul style="list-style-type: none"> • Not a Hazardous Condition. • No Corrective Action Required.

UNCONTROLLED IF PRINTED

<p>Measured Voltage at 15 Volts or Greater</p>	<p>Electric Department / Corrosion Tech to Investigate Source and Determine Corrective Action.</p>	<p>Electric Service person to notify Customer they have excessive voltage on their piping. Advise Customer to contact an electrician or HVAC contractor.</p>	<p>Electric Department / Corrosion Tech to Investigate Source and Determine Corrective Action.</p>
--	--	--	--

7.3.2 In non-Ameren electric service areas, Dispatcher should contact the appropriate electric service provider to request assistance.

7.3.3 The best remedial action for AIC facilities is to control the AC voltage at the source.

7.4 Inspections/Maintenance on Meter Sets

7.4.1 Perform the following checks when installing/changing gas meter or doing any work on the meter set:

1. Before touching meter set, check for possibility of AC voltage with a "volt stick". If voltage is detected, see [Subsection 7.2](#).
2. Check riser at the soil-to-air interface for disbonded coating and corrosion and address corrective action in accordance with [CORR 1, Subsection 15.5](#).
3. Check aboveground piping for atmospheric corrosion in accordance with [CORR 1, Section 15.0](#), Atmospheric Corrosion. Repair coating and paint meter set where needed. See [CORR 1, Section 16.0](#), Painting Pipeline Facilities.
4. Check the 10LT meter spud for corroded welds and replace when corrosion is encountered. See Figure 2.



Figure 2: RW Lyall 10LT Corroded Meter Spud Welds

5. Check meter header for strain on piping; ensure that it is essentially level.
6. Check that the riser meter valve is accessible.
7. Check or ensure meter is not partially buried or setting on ground.
8. Check for old abandoned risers that were not cut off below ground level when service was replaced. If encountered, cut off 6" below grade.
9. Check regulator for proper installation, to include bug screen being clear, relief properly/freely vented to atmosphere, and spring cap.
10. Check the meter set for foreign grounding from telephone or cable TV; report to Gas Supervisor for follow up action when encountered.
11. Check banded regulators for corroded band bolts and replace regulator when encountered. See [Appendix B, Figure B-1](#) for images of banded regulators.

UNCONTROLLED IF PRINTED

12. Check for substandard regulators and report to Gas Supervisor when encountered. See [Appendix B, Figure B-2](#) for images of substandard regulators.

Whenever a substandard regulator is identified that may contain mercury, notify the Gas Supervisor. Do not replace, remove, or disturb the regulator without specific handling instructions from AIC Environmental & Safety.

13. Check for Fisher 254 or American 1213B meter bar regulator assembly and install a vent/splash guard where encountered.
 14. Whenever any above deficiencies are noted, correct immediately or document in ClickMobile and report to Gas Supervisor for follow-up action.
- 7.4.2 If disassembling the meter set, perform the added corrective action or maintenance as follows:
1. Replace Mueller interlock meter valves or other obsolete or defective meter valves.
 2. Grease meter hubs with "NO-OX-IDE" grease.

7.5 Regulator Vent/Splash Guard

- 7.5.1 Gas field personnel to install a regulator guard when a meter-bar type regulator (either Fisher 254 or American 1213 B) is encountered while performing work on customer premises.
- 7.5.2 The guards (stock code 62 56 266) are for regulators with a $\frac{3}{4}$ " NPT relief vent opening. Ensure that the relief vent outlet and guard threads are the same size before beginning to insert.
- 7.5.3 The installation process for regulator guards is as follows:
 1. Remove and discard the original screen from relief vent opening.
 2. Check both the relief vent opening and the guard opening to ensure there are no obstructions.
 3. Apply a light coating of pipe joint compound to the exposed guard threads.
 4. Using both hands, position the guard beneath the relief vent opening. Hand-tighten the guard until top of guard seats snugly against the vent base.

Over-tightening the guard into the vent base might cause damage to the guard.

5. For a picture of the completed assembly showing regulator guard in the meter bar type regulator, see [Appendix B, Figure B-3](#).

8.0 Records and Retention

- 8.1 File and retain all new inspection records in Click, Maximo, or OAS. However, some historical records may be retained in their paper form.

- 8.2 See the expanded and consolidated summary titled "Meter Test Schedules & Retention Requirements" located in [METR 4](#) under References. (in support of METR 2.2, 2.3, and 2.4).

End of Instructions.

Operator Qualification (OQ) Required?

YES

0201: Visual Inspection of Installed Pipe and Components for Mechanical Damage

0301: Manually Opening and Closing Valves

0381: Spring Loaded Pressure Regulating Device-Inspection and Testing, Preventive and Corrective Maintenance

0591: Leak Test at Operating Pressure

0641: Visually Inspect Pipe and Components Prior to Installation

0711: Joining of Pipe - Compression Couplings

0721: Joining of Pipe - Threaded Joints

0731: Joining of Pipe - Flange Assembly

0951: Installation of Pipe Above Ground

0961: Above Ground Supports and Anchors-Inspection, Preventive and Corrective Maintenance

1161: Installation of Meters and Regulators - Residential and Small Commercial

1171: Installing Meters - Large Commercial and Industrial

1181: Installing and Maintaining Pressure Regulating, Limiting, and Relief Device - Large Commercial & Industrial

1191: Maintenance of Service Valves Upstream of Meter

1201: Temporary Isolation of Service Lines and Service Discontinuance

A001: Service Reconnect

A003: Emergency Response

Appendices

[Appendix A - AC Voltage Potential at Meter Set](#)

[Appendix B - Regulator Related Pictures](#)

Attachments

NONE.

Compliance Requirements

Illinois Commerce Commission (ICC) Title 83: Public Utilities, Part 501, Standards of Service for Gas Utilities and Alternative Gas Suppliers, specifically Subpart B: Natural Gas Measurement Requirements, available online [here](#).

Reference Documents

UNCONTROLLED IF PRINTED

AIC Reference Forms:

Gas Instrument Calibration Data Sheet

Reference Meter Test Results Report / Weekly Gas Reference Meter [Test] Results Report

[METR 1 Metering: Requirements](#)

[METR 2.3 Metering: Meter Inspection and Testing - Shop](#)

[METR 2.4 Metering: Meter Inspection and Testing - GTS](#)

[METR 4 Metering: Forms and Reference Materials](#)

Document Rescission

METR 2.2 Metering – Meter Inspection and Testing, December 15, 2021

Revision Notes

Location of Changes	Summary of Changes
Paragraph 7.2.2 – Volt Stick	Updated Stock Code, 60 05 635, for volt stick model NCVT-4IR. Previous Stock Code, 65 36 383, is being directed to new Stock Code.

Appendix A - AC Voltage Potential at Meter Set

A-1. Overview

A-1.1 An AC voltage risk associated with the utility gas system occurs at the connection with customer. Many older homes relied upon the water piping systems for grounding. Over the years, some of these electrical grounds have been disconnected or rendered inoperable by the installation of plastic water lines in and outside the house. In such cases, if an electrical appliance goes to ground it can energize the gas fuel line through the hot water heater, or in the case of a furnace, at the furnace itself. This can cause up to 120 V AC to appear on the fuel line which creates 120V potential between the gas service and the customer fuel line.

A-1.2 If insulated meter spuds are used, the meter and the fuel line can also be at 120 V AC potential difference.

A-2. Code and Standard References Related to AC Grounding and Gas Piping

A-2.1 The NEC specifically prohibits using underground gas piping as a grounding electrode.

250.52 Grounding Electrodes

(B) Electrodes Not Permitted for Grounding: The following shall not be used as grounding electrodes:

- (1) Metal underground gas piping system
- (2) Aluminum electrodes

A-2.2 The National Association of Corrosion Engineers (NACE) has a Recommend Practice RP 0177-2000 that defines a shock hazard as 15 volts AC:

"Shock Hazard: A condition considered to exist at an accessible part in a circuit between the part and ground or other accessible part if the open-circuit AC potential is more than 15 V (root mean square [rms]) and capable of delivering 5 mA or more."

A-2.3 The National Fuel Gas Code Handbook (2009 Edition) (NFPA 54) sections 7.13 *Electrical Bonding and Grounding*, 7.14 *Electrical Circuits*, and 7.15 *Electrical Connections* address the grounding of gas fuel lines. Per this code, gas fuel lines are to be grounded but are not to be used as a grounding conductor.

A-3. AC Voltage Check at Customer Meter Sets

A-3.1 Before performing any work on a gas meter set, use a voltage stick to check for AC voltage on the locations listed below. See [Subsection 7.2](#), AC Voltage on Meter Set.

A-3.1.1 Service riser.

A-3.1.2 Meter.

A-3.1.3 Customer fuel line.

A-3.2 Do not work on the meter set if the measured voltage is 15 volts or higher until the voltage source has been eliminated. See Table 5, under [Subsection 7.3](#), AC Voltage Action Table which addresses voltage found at 1) riser, 2) customer piping, or 3) both the riser and customer piping.

A-4. Measuring AC Procedure (If needed in addition to voltage stick)

A-4.1 Connect leads from Digital Multimeter (DM) as follows:

A-4.1.1 Red lead to volt/ohm terminal.

A-4.1.2 Black lead to common terminal.

A-4.2 Select VAC (volts AC) choice on DM/voltmeter.

A-4.3 Connect clip end of red lead to pipe or structure to be tested.

A-4.4 Connect clip end of black lead to the half-cell.

A-4.5 Remove orange protective cap from reference electrode.

A-4.6 Place the porous plug of electrode into moist soil.

A-4.7 Observe and record reading.

Appendix B - Regulator Related Pictures

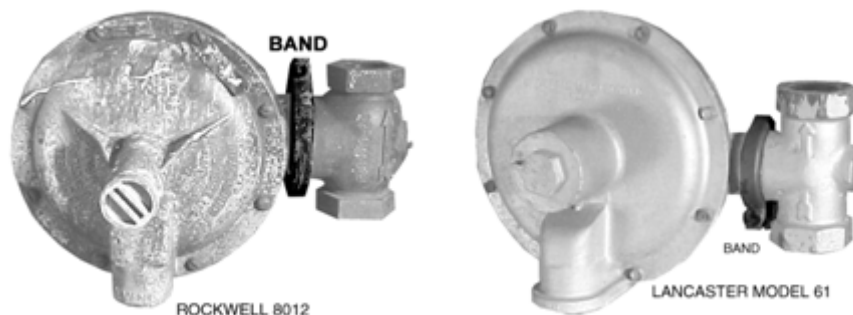

Figure B-1: Banded Regulators

UNCONTROLLED IF PRINTED

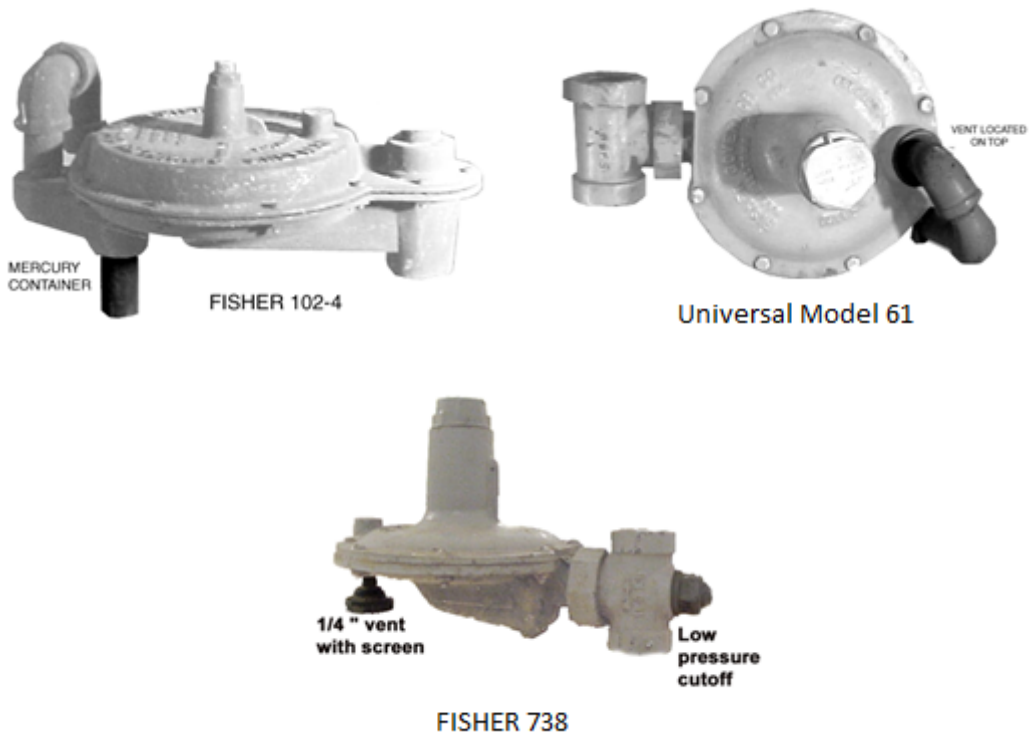

Figure B-2: Substandard Regulators



Figure B-3: Regulator with "Regulator Guard"

End of Appendices

METERING

October 1, 2020

METR 2.3 Meter Inspection and Testing - Shop

1.0 Purpose

This procedure identifies requirements for various testing of Ameren Illinois (AIC) gas meters and testing equipment to meet or exceed accuracy limits and schedules established by the Illinois Commerce Commission (ICC). It includes the various criteria and guidelines governing the testing programs applicable to shop activities.

2.0 Scope

This document addresses the following:

[3.0 Target Audience](#)

[4.0 General](#)

[5.0 Prover Certification](#)

[6.0 Bell Prover Testing - Not used by AIC for testing gas meters](#)

[7.0 Transfer Prover Testing](#)

[8.0 New Meter Testing](#)

[9.0 Records and Retention](#)

Appendices

[Appendix A - Meter Flow Rates](#)

3.0 Target Audience

- Gas Engineering
- Gas Supervisors
- Gas Field Personnel
- Gas Technical Services (GTS) Supervisor
- Gas Meter Supervisor
- Gas Meter Shop Foreman
- IL Metering and Projects Supervisor

4.0 General

4.1 For related coverage and requirements, see METR 1 as follows:

4.1.1 Definitions and sizing of equipment - [Section 4.0](#).

4.1.2 Care and handling of meters - [Section 5.0](#).

5.0 Prover Certification

5.1 General

5.1.1 Calibrate and certify all sonic-nozzle provers at least every *12 months*.

5.1.2 Recertify all transfer provers at least every *36 months* by either:

1. Sending (in protective crate) to an approved certification service, or
2. Recertify locally by an approved contract service.

UNCONTROLLED IF PRINTED

- 5.1.3 Require all gas meter testing contractors used to repair and test AIC meters to provide *proof annually* that their testing equipment has been *certified within the last 36 months*, or at least every *12 months for sonic-nozzle provers*.

5.2 Verification of Meter Shop Reference Meters

- 5.2.1 Perform a verification test weekly on each transfer prover by using an AL800 reference meter.
- 5.2.2 Perform a verification test weekly on each operating sonic-nozzle prover by using the following non-temperature compensating reference meters:
 1. American AC250: For meters having a badge capacity rating of 275 cfh or less.
 2. American AL425: For meters having a badge capacity rating greater than 275 cfh.

5.3 Documentation of Reference Meter Verifications

- 5.3.1 Record the following test data in MMS for each operating prover that is tested with a reference meter:

1. Date of test.
2. Banner Eye:
 - 2 a. Open rate results (% accuracy).
 - 2 b. Open rate time.
 - 2 c. Check rate results (% accuracy).
 - 2 d. Check rate time.
 - 2 e. Average accuracy (%).
3. AIMS:
 - 3 a. Open rate results (% accuracy).
 - 3 b. Check rate results (% accuracy).
 - 3 c. Average accuracy (% accuracy).

- 5.3.2 From MMS (reports section), run the Reference Meter Test Results Report for each operating meter shop reference meter.

- 5.3.3 Log the results on each prover for a visual reference of the bell or sonic-nozzle prover's accuracy and to assist with determining when corrective actions are required.

- 5.3.4 The Gas Metering Supervisor for each meter shop is responsible to review the reference meter logs weekly and shall initiate appropriate actions to correct accuracy deficiencies.

5.4 Corrective Actions

- 5.4.1 When performing a *weekly reference meter verification test*, corrective action may be required for one or more of the provers being tested. Take corrective actions when any of the following occurs:

1. Percent accuracy of the open rate test or check rate test exceeds $\pm 0.5\%$ from the other provers.
2. Spread between open rate and check rate exceeds 1.0%.

UNCONTROLLED IF PRINTED

3. Average percent accuracy between provers exceeds 0.5%.
 4. Variance between the banner eye and AIMS exceeds 0.5%.
 5. Prover room temperature fluctuates more than 4°F during any 24-hour period.
- 5.4.2 Perform an additional verification test after any corrective actions are taken to verify the provers are operating within established accuracy limits.
 - 5.4.3 Document all corrective actions that are completed on the Weekly Gas Reference Meter [Test] Results Report.
 - 5.4.4 Each meter shop shall document weekly a reference meter verification test for each meter and prover combination.

If there is no meter testing activity during a given week, a reference meter verification test is not required. Complete the Weekly Gas Reference Meter [Test] Results Report to indicate that no meter testing was performed during that week.

6.0 Bell Prover Testing - Not used by AIC for testing gas meters

7.0 Transfer Prover Testing

7.1 General

- 7.1.1 This procedure outlines the testing of meters with a capacity of 630 cfh or greater using a transfer prover.

7.2 "In-testing" Preparation

- 7.2.1 All meters removed from service must be in-tested prior to repair or retirement. Test those meters having a capacity of 630 cfh or greater with a transfer prover or sonic-nozzle prover of required capacity.

If there is an AMR device attached, check to ensure that the battery has been disconnected.

- 7.2.2 Purge and exercise meter prior to testing.

Recommend the prover hose have one loop in the hose when proving rotary meters.

- 7.2.3 Each meter shall be tested at the following flow rates of the meter badge capacity:
 1. Check-flow rate: Must be between 20% and 33%. Use approximately 30% for consistency.

2. Open-flow rate: Must be at approximately 100%.

7.2.4 See [Appendix A](#) for the check-flow rates and open-flow rates, along with the test volume, for each size meter.

7.2.5 For greater than 10,000 cfh capacity meters, the check-flow rate will be 30% of meter capacity, if possible, and open-flow rate will be the maximum prover volume capability.

7.3 In-testing Meters

7.3.1 When a meter is in-tested, complete the following activities:

1. Select the correct preconfigured test.
2. Verify the correct master meter has been selected.
3. Begin the test by selecting "Start" button.
4. Verify the temperature has stabilized. Test will automatically start when stabilized.
5. Ensure all tests are greater than 30 seconds duration.
6. After completing the test, verify the results for inaccuracies. The meter must be retested if it appears the test results are not correct and/or the prover did not function properly.
7. Enter the test results into MMS.

7.3.2 Cap the meter hubs.

7.4 Test Results

7.4.1 Record the following data and enter in MMS:

1. Meter readings.
2. Test results (% accuracy).
3. Differential test results for both the check-flow rate and open-flow rate.

7.4.2 Verify all other information listed in MMS for accuracy.

7.4.3 Record test results for non-registering or damaged meters as 0% on the check-flow rate and open-flow rate. Record this information in the comment column and on the test type.

7.4.4 Meters that are obsolete or damaged can be retired at the receive station, in-test station, or set aside for retirement later.

7.5 Adjust-Testing

7.5.1 When a meter is repaired by AIC or a contractor, it must be "adjust-tested" prior to installation. Complete the adjust-test using the same procedures described previously for in-testing a meter.

7.5.2 Adjust all diaphragm meters to test within $\pm 0.5\%$ of 100% average accuracy and have no more than 1.0% spread between the check-flow rate and open-flow rate tests.

7.5.3 All rotary meters shall have an average adjust-test accuracy of $\pm 0.75\%$ of 100% accuracy and no more than 1.0% spread between the check-flow rate and open-flow rate test results.

UNCONTROLLED IF PRINTED

1. If the initial adjustment test is out of tolerance, adjust meter and re-test until it meets these specifications.
2. Retire meters that cannot be adjusted to specifications.

7.5.4 Check output pulses on rotary meters for proper operation.

7.6 AMR Device Verification

7.6.1 Verify all meters that have an AMR module by the GPREP software to ensure the following items are programmed correctly.

1. Meter serial number.
2. Meter manufacture code.
3. Module ID or LAN ID.
4. Meter constant or drive rate.
5. Reading.
6. Rollover point or reading at which meter will again start at zero.

8.0 New Meter Testing

8.1 General

8.1.1 New gas meters will be tested in accordance with the regulatory requirements of the ICC.

8.2 Diaphragm Meters

8.2.1 Enter all diaphragm gas meters purchased by AIC into MMS per manufacturer's file by the following steps *under the heading "Meter Data"*:

1. Add New Meters.
2. Manufacturer File.
3. Params (tab) - Enter information.
 - 3 a. Query the input file. This will automatically populate the Qty. field.
 - 3 b. Index Reading.
 - 3 c. Meter Code.
 - 3 d. Drive Rate.
 - 3 e. Purchase Date.
 - 3 f. Inventory Status.
 - 3 g. Shop Location.
 - 3 h. Removal Code, required.
 - 3 i. Repair Code.
 - 3 j. Service Center.
 - 3 k. Check Random Sample box.
 - 3 l. Module.
 - 3 m. Select Appropriate File Profile.
 - 3 n. Select OK.

UNCONTROLLED IF PRINTED

4. Preview (tab)

- 4 a. By selecting the "OK" button on the Param tab, the screen shifts to the preview tab and will automatically download the manufacturer's information to MMS.
- 4 b. Review downloaded information on the screen by checking test results, meter numbers, and quantity. Note the lot number that was generated by selecting the Random Sample box.
- 4 c. Select "OK" again to load meters into database.

8.3 Sample Testing Basis - New Diaphragm Meters

- 8.3.1 Randomly sample all new diaphragm meters purchased using ANSI/ASQ Z1.4-2008 single sampling for normal inspections, Inspection Level II with an AQL of 1.0% and accuracy between 99.25% - 100.75%.
- 8.3.2 Evaluate sample lots by using the Kolmogorov-Smirnov (K-S) Test with a (K-S) value of 95%.
- 8.3.3 Use Table 1 to determine the number of meters to be sampled.
- 8.3.4 The reject column identifies the number of meters that must fail the accuracy requirements, differential requirements, and/or spread requirements to reject the entire lot.

Table 1: Meter Sampling

Single Sampling New Meters and Modules		
Lot Size	Sample Size	Reject Number
2 to 8	2	1
9 to 15	3	1
16 to 25	5	1
26 to 50	8	1
51 to 90	13	1
91 to 150	20	1
151 to 280	32	2
281 to 500	50	2
501 to 1200	80	3
1201 to 3200	125	4
3201 to 10,000	200	6
10,001 to 35,000	315	8
This Table is based on ANSI/ASQ Z1.4-2008, General Inspection Level II - Single Sampling Plan for Normal Inspection		

8.4 Sample Selection - New Diaphragm Meters

- 8.4.1 When loading new diaphragm meters in MMS by batch or by manufacturer's file (see [Paragraph 8.2.1](#)), a new sample lot number is produced once the Random Sample box is checked. The lot number is populated in the New Meter Random Selection file.

- 8.4.2 Select this file from the Meter Data menu. Choose the assigned sample lot number. Query this lot number to populate the fields. Select "ANSI/ASQ Z1.4-2008 New Meter" as the sample standard and Inspection Level II.
- 8.4.3 The appropriate sample size should be displayed based on the Lot Size.
- 8.4.4 Check the manual selection box and then select the serial numbers of the meters randomly chosen for sample based upon [Table 1](#).
- 8.4.5 MMS has the capability to randomly select individual meters from the new meter lot.
- 8.4.6 Deselecting the manual selection box and selecting the "Random" button will populate a system generated list of meters randomly chosen.
- 8.5 Testing New Diaphragm Meters (Samples)
 - 8.5.1 Temper the meters in the prover room at table height for a minimum of 12 hours. The gas meters should come from the manufacturer with a Form 120 sticker attached, which includes a bar code.
 - 8.5.2 After the meters have been tempered, test the meters with the appropriate prover testing equipment.
- 8.6 Evaluate New Meter Samples
 - 8.6.1 After all the sample meters have been tested, evaluate the lot by using the "Evaluate New Meter Sample" program in MMS under Meter Data menu.
 - 8.6.2 Select the lot number to evaluate and query.
 - 8.6.3 The evaluation unit for new meters will be "Other" and the evaluation method will be Kolmogorov-Smirnov (K-S) Test.
 - 8.6.4 AIC will evaluate new meters based on the open, check, differential, and spread results, with a K-S% of 95%.
 - 8.6.5 Once these criteria are specified, select the method button to move to the Evaluate tab, where:
 - 1. AQL should be 1.0,
 - 2. Sampling technique will be Attributes, AND
 - 3. Normal inspection.
 - 8.6.6 Set the limits for Proof 99.25% - 100.75%, differential 0.00 - 0.50, and spread 0.00 - 1.00 and evaluate.
 - 8.6.7 Each meter must fall within the limits set for proof, differential, and spread to pass.
 - 8.6.8 The lot will PASS or FAIL based upon the criteria listed in [Table 1](#).
 - 8.6.9 If the lot passes, then, (from the process lot tab) ensure the inventory status, shop location, and service center are all correct.
 - 8.6.10 Select "OK" to accept the evaluation. The inventory status of all meters in the lot will be changed to available.
 - 8.6.11 If the lot fails, a second sample will be performed.
 - 1. If the 2nd sample passes, AIC will accept the meters.

2. If the 2nd sample fails, the manufacturer will be notified of the results and the meters will be shipped back to the manufacturer (freight collect) or AIC will test the entire lot at the manufacturer's expense.

8.7 Rotary and Turbine Meters

- 8.7.1 New rotary and turbine meters may be sample tested following the same procedures as those for diaphragm meters. Depending on the quantity of rotary or turbine meters received, all the meters (in the small lot) may require that each be tested.
- 8.7.2 Meters will be tested in accordance with the Transfer Prover Testing procedure (see [Section 7.0](#)), or the Turbine Meter Testing procedure (see [METR 2.4, Section 6.0](#)).
- 8.7.3 All meters must have accuracy between 99.25% - 100.75% and be within a 1% spread.
- 8.7.4 If a meter (or lot) is found to be outside the acceptable range, manufacturer will be notified, and meter(s) will be shipped to the manufacturer (freight collect).

8.8 Test Results

- 8.8.1 Maintain all test results from the manufacturer or from testing by AIC personnel in MMS or as a paper document.

9.0 Records and Retention

- 9.1 In summary, file and retain all new inspection records in Click, Maximo, or OAS. However, some historical records may be retained in their paper form.
- 9.2 See the expanded and consolidated summary titled "Meter Test Schedules & Retention Requirements" located in [METR 4](#) under References. (in support of METR 2.2, 2.3, and 2.4).

End of Instructions.

Operator Qualification (OQ) Required?

NO.

Appendices

[Appendix A - Meter Flow Rates](#)

Attachments

NONE.

Compliance Requirements

Illinois Commerce Commission (ICC) Title 83: Public Utilities, Part 501, Standards of Service for Gas Utilities and Alternative Gas Suppliers, specifically Subpart B: Natural Gas Measurement Requirements, available online [here](#).

Reference Documents

AIC Reference Form: Reference Meter Test Results Report / Weekly Gas Reference Meter [Test] Results Report

[METR 1 Metering: Requirements](#)

UNCONTROLLED IF PRINTED

[METR 2.2 Metering: Meter Inspection and Testing - Field](#)

[METR 2.4 Metering: Meter Inspection and Testing - GTS](#)

[METR 4 Metering: Forms and Reference Materials](#)

Document Rescission

METR 2.06 Metering: Prover Accuracy Certification and Verification, January 1, 2017.

METR 2.07 Metering: Bell Prover Testing, January 1, 2017.

METR 2.08 Metering: Transfer Prover Testing, January 1, 2017.

METR 2.26 Metering: New Meter Testing, January 1, 2018.

Revision Notes

Location of Changes	Summary of Changes
Not applicable.	This is a new document.

Appendix A - Meter Flow Rates

Meter Size	Check-Flow Rate (cfh)	Volume	Open-Flow Rate (cfh)	Volume
630	189.0	2 cu. ft.	630.0	10 cu. ft.
675	200.0	10 cu. ft.	675.0	20 cu. ft.
750	225.0	10 cu. ft.	750.0	20 cu. ft.
800	240.0	10 cu. ft.	800.0	50 cu. ft.
Rotary 8C	240.0	10 cu. ft.	800.0	50 cu. ft.
1000	300.0	10 cu. ft.	1000.0	50 cu. ft.
Rotary 11C	330.0	10 cu. ft.	1100.0	50 cu. ft.
80B	360.0	20 cu. ft.	1200.0	50 cu. ft.
1400	420.0	10 cu. ft.	1400.0	50 cu. ft.
Rotary 15C	450.0	10 cu. ft.	1500.0	50 cu. ft.
1600	480.0	10 cu. ft.	1600.0	50 cu. ft.
Rotary 2M	600.0	10 cu. ft.	2000.0	50 cu. ft.
2300	690.0	20 cu. ft.	2300.0	50 cu. ft.
250B	900.0	20 cu. ft.	3000.0	100 cu. ft.
3000	900.0	20 cu. ft.	3000.0	100 cu. ft.
Rotary 3M	900.0	20 cu. ft.	3000.0	100 cu. ft.
Rotary 3.5M	1050.0	20 cu. ft.	3500.0	100 cu. ft.
500B	1440.0	50 cu. ft.	4800.0	200 cu. ft.
5000	1500.0	20 cu. ft.	5000.0	100 cu. ft.
Rotary 5M	1500.0	20 cu. ft.	5000.0	100 cu. ft.
Rotary 5.3M	1590.0	20 cu. ft.	5300.0	100 cu. ft.
4 1/2	2100.0	50 cu. ft.	7000.0	100 cu. ft.
Rotary 7M	2100.0	50 cu. ft.	7000.0	100 cu. ft.

UNCONTROLLED IF PRINTED

10000	3000.0	50 cu. ft.	10000.0	200 cu. ft.
-------	--------	------------	---------	-------------

End of Appendices

METERING

October 1, 2022

METR 2.4 Meter Inspection and Testing - GTS/GCD

1.0 Purpose

This procedure identifies requirements for various testing of Ameren Illinois (AIC) gas meters and testing equipment to meet or exceed accuracy limits and schedules established by the Illinois Commerce Commission (ICC). It includes the various criteria and guidelines governing the inspection and testing programs applicable to Gas Technical Services (GTS) and Gas Control and Dispatch (GCD) activities.

2.0 Scope

This document addresses the following:

[3.0 Target Audience](#)

[4.0 General](#)

[5.0 Rotary Meter Differential Testing](#)

[6.0 Turbine Meter Testing](#)

[7.0 Ultrasonic Meter Testing](#)

[8.0 Records and Retention](#)

3.0 Target Audience

- Gas Engineering
- Gas Tech Services (GTS) Supervisor
- Gas Tech Services (GTS) Technicians
- Supervisor, Gas SCADA
- Gas Control Technicians (GCT)
- Gas Meter Supervisor
- Gas Meter Shop Foreman
- IL Metering and Projects Supervisor
- Gas Control and Dispatch

4.0 General

4.1 For related coverage and requirements, see [METR 1](#) as follows:

4.1.1 Definitions and sizing of equipment - [Section 4.0](#).

4.1.2 Care and handling of meters - [Section 5.0](#).

4.1.3 Gas meter locations - [Section 6.0](#).

4.1.4 Installation considerations - [Section 7.0](#).

4.2 For Customer Requested Test, see [METR 2.2, Section 6.0](#).

5.0 Rotary Meter Differential Testing

5.1 General

5.1.1 *Differential pressure testing* is the industry standard for testing rotary gas meters at a service location and is done by measuring the pressure drop across the meter inlet and outlet.

UNCONTROLLED IF PRINTED

5.1.2 Any significant increase in the rotary meter's internal resistance to flow at a known volume and pressure will increase the pressure drop across the meter. Therefore, rotary meter differential test is a prime indicator of meter condition. Items that can cause an increase in the internal resistance of a rotary meter include:

1. Binding of the impellers,
2. Dirt or debris,
3. Worn bearings,
4. Oil too heavy, and/or
5. Incorrect oil level.

5.1.3 Manufacturer test results have shown that an increase of up to 50% in differential pressure can be tolerated without affecting the rotary meter accuracy by more than 1% at flow rates of 10% to 100% of meter capacity.

5.2 Initial Differential Test

5.2.1 Perform a differential test on each new rotary gas meter installation to establish an acceptable differential (and baseline reference) related to individual piping configurations and operating pressures. See [Subsection 5.5](#) for test procedure.

5.2.2 Complete the initial test within *6 months* of the meter's "In Service" date.

5.2.3 Complete the differential test by establishing a minimum flow rate of 10% of the meter capacity.

5.2.4 The initial test will establish the "Last Test Date", which is used to determine when the meter is due for the next periodic meter test.

5.3 Periodic Test

5.3.1 Complete a differential test by establishing a minimum flow rate of 10% of the meter capacity. See [Subsection 5.5](#) for test procedure.

5.3.2 Perform a differential test on in-service rotary meters at least *every 60 months* from the last test date to verify that the differential pressure does not exceed 50% increase over the following:

1. Initial differential test, OR
2. Manufacturer's acceptable limits.

5.3.3 If operating conditions prevent getting a meter differential pressure reading and conditions are properly documented, then verification may be delayed until test can be conducted or 4 months, whichever is shorter.

If verification is delayed due to operating conditions, maintain documentation for 3 years addressing conditions that prevented verification within the required 60 months. If requested, provide documentation to authorized Commission representative.

5.3.4 In lieu of differential pressure testing, an accuracy test may be done on the rotary meter. See [METR 2.3, Section 7.0](#) for transfer prover testing. The average

accuracy is determined by averaging the accuracy at the check flow and open flow rates.

5.4 Equipment

5.4.1 *Differential measurement:* Use an electronic instrument or manometer to measure the differential pressure on all rotary gas meters as follows:

1. Range readable to 0.10 inches water column (W.C.) or 0.10 psig,
2. Pressure rating must be good for the operating pressure of the meter being tested.
3. Examples of acceptable electronic instruments include:
 - 3 a. Meriam Smart Manometer.



- 3 b. Versi-Test Calibrator.



A liquid manometer is an acceptable alternative.

5.4.2 *Timing device:* A clock, stop-watch, or other timing device is required to time the meter for calculating flow rate through the meter. However, an electronic index capable of displaying flow rate could eliminate the need for a separate timing device.

5.4.3 *Pressure gauge:* A calibrating gauge (see [METR 2.6](#)) is required to measure the operating pressure on the meter.

5.4.4 *Computer:* A laptop with current software version installed as applicable:

1. Dresser's Differential Test Acceptance Calculator (dP Calculator) - for Dresser meters,
2. Romet Differential Calculator - for Romet meters, or
3. Manufacturer's factory differential pressure curves - acceptable alternative for reference.

5.5 Differential Test

The following activities are required to provide accurate differential test results:

UNCONTROLLED IF PRINTED

- 5.5.1 Install a calibrating gauge to measure the meter pressure.
- 5.5.2 Install the differential pressure test equipment into the meter inlet and outlet differential taps. Follow the manufacturer's instructions for proper installation and operating procedures.
- 5.5.3 Verify or establish a stable flow through the meter. The minimum flow rate for a proper test must be 10% of the meter capacity.
- 5.5.4 Time/clock the meter or interrogate the meter's electronic index to determine if the minimum test flow requirement is met.
- 5.5.5 Record differential pressure reading, metering pressure, and test flow rate. The flow rate is either calculated or read from an electronic index.
- 5.5.6 Repeat the test to verify an accurate average reading.
- 5.5.7 Compare test data to existing manufacturer's factory differential pressure base-line curves or use laptop software as listed in [Paragraph 5.4.4](#) to determine the condition of the meter (**PASS** or **FAIL**).

Be sure to use dP Calculator software on Dresser meters and Romet Calculator software on Romet meters.

- 5.5.8 Remove all test equipment and confirm the meter is returned to normal operating conditions.
- 5.5.9 Ensure pressure sensing line to the corrector is in open or "On" position.

5.6 Test Record

- 5.6.1 Record the following items to document the differential test:
 - 1. Test date.
 - 2. Employee performing test.
 - 3. Calculated flow rate (cfh).
 - 4. Meter pressure.
 - 5. Differential pressure.
 - 6. Index reading.
- 5.6.2 Show results, as applicable, to manufacturer's acceptable curve, Dresser's Differential Test Acceptance Calculator (dP Calculator), or Romet Differential Calculator for **PASS** or **FAIL** resultant.
- 5.6.3 Any maintenance activities performed on the meter (e.g., meter oil change, flushing meter).

5.7 Follow-up Action

- 5.7.1 Check the recorded differential pressure against the following:
 - 1. Factory Characteristic Accuracy and Differential Curves,
 - 2. dP Calculator,
 - 3. Romet Differential Calculator,

UNCONTROLLED IF PRINTED

4. Prover Test Curves, OR
5. Graphs generated from differential pressure test data obtained during the initial installation.

5.7.2 If differential is more than 50% higher than AIC's initial differential test or manufacturer's differential curve, the meter is not functioning properly.

1. Perform corrective maintenance on the meter in the field to reduce differential pressure to an acceptable level and retest within 7 days, or possibly exchange the meter if the differential pressure cannot be reduced.
2. Corrective maintenance might include:
 - 2 a. Changing the oil, OR
 - 2 b. Cleaning the meter impeller chamber, i.e., flushing with an approved solvent.
3. If the pressure differential cannot be reduced to less than a 50% increase over the original value, then the meter must be replaced within 60 days.

5.7.3 If replacement is required and meter is of sufficient size that portions of customer's structure require modification to remove meter, then AIC will replace the meter within 90 days unless AIC and customer agree to a longer period, not to exceed 180 days.

5.7.4 Send removed meters promptly to the gas meter shop for testing and corrective action.

5.7.5 Schedule corrective maintenance activity or meter replacement if it cannot be accomplished during the initial site visit.

5.8 AMR/AMI Reading Verification

5.8.1 Verify AMR/AMI (automated meter reading / advanced metering infrastructure) reads are in alignment with field meter readings.

5.8.2 AMR/AMI readings lag field readings by 24-48 hours. The 7-day history function on the AMRC screen in OAS can be used to help determine alignment.

5.9 Rotary Meter Records

5.9.1 Maintain the differential test results for life of the meter in MMS.

5.9.2 Historical test results may be maintained in MMS or as a paper record.

6.0 Turbine Meter Testing

6.1 General

6.1.1 Spin testing is the industry standard for testing turbine gas meters at a service location and is done by measuring the time required for the meter rotor to stop spinning.

6.1.2 Accuracy testing of turbine meters shall be done by an actual calibration accuracy test.

6.2 Testing Requirements

6.2.1 Turbine Spin Test

1. If meter is equipped with external lubrication fittings, spin test and, if necessary, lubricate the turbine at least every 12 months.

UNCONTROLLED IF PRINTED

2. If meter is not equipped with external lubrication fittings or external means of verifying meter operation, then spin test every 6 months. The single-rotor turbine meter might require the measurement cartridge be physically removed from the meter body for spin testing.
3. A spin test is not required for a dual-rotor turbine meter if it has an external means of verifying rotor condition, then verify rotor condition at least every 6 months to ensure the rotor performance meets the manufacturer's guidelines.
4. Dual-rotor turbine meters have the technology to perform a "spin-down" test while the rotors are still installed in the meter body.

6.2.2 Turbine Accuracy Test

1. Perform accuracy test on single-rotor turbine meters at least every *60 months*. Complete test as follows:
 - 1 a. Use at least 4 different flow rates when testing atmospherically and 5 different flow rates when testing at the expected operating pressure.
 - 1 b. Test pressure shall fall within the range of 50% less than or 2 times greater than the meter operating pressure.
 - 1 c. Meter can be accuracy tested with natural gas or air. When using air, the test shall account for the Reynolds number equivalent.
2. For a dual-rotor turbine meter that has an external means of verifying meter accuracy, perform an accuracy test at least every *120 months providing*:
 - 2 a. The meter accuracy is verified at least every *6 months*, AND
 - 2 b. Meter performance meets the manufacturer's guidelines.

6.3 Required Equipment

- 6.3.1 A clock, stop-watch, or timing device to measure the time required for the meter rotor to stop spinning.
- 6.3.2 A calibrating gauge (see [METR 2.6](#).) to measure the operating pressure on the meter.
- 6.3.3 Prover equipment with enough capacity to test meter accuracy at a single flow rate between 10% and 105% of the rated capacity.

6.4 Spin Test

The following activities are required to provide accurate spin test results:

- 6.4.1 Check meter pressure.
- 6.4.2 Perform spin test in a draft free area with the measuring cartridge in its normal operating position. Place a wind block on the downstream or outlet side of cartridge.
- 6.4.3 Spin the rotor vigorously.
- 6.4.4 Time or clock the rotor to determine time required for rotor to stop spinning.
- 6.4.5 Repeat test at least 3 times to verify an accurate average reading.
- 6.4.6 Record the spin time.

6.5 Minimum Spin Times

UNCONTROLLED IF PRINTED

6.5.1 Table 1 and Table 2 and Table 3 list the minimum spin times recommended by the manufacturer for out-of-body cartridge assemblies with plastic rotors.

Table 1: American GT Turbo-Meters - Spin Times

Model	3-GT	4-GT	6-GT	8-GT	12-GT
Size (Inches)	3	4	6	8	12
Seconds	50	30	65	90	100

Table 2: Rockwell Mark II Turbo-Meters - Spin Times

Model	T-18	T-30	T-60	T-140
Size (Inches)	4	6	8	12
Seconds	50	140	180	300

Table 3: Sensus Auto-Adjust Turbine Meters – Spin Times
Minimum Spin Times w/o readout at ambient air temperature

Main Rotor							
Meter	Size	Above 59°F (seconds)	59°F to 50°F (seconds)	50°F to 40°F (seconds)	40°F to 30°F (seconds)	30°F to 19°F (seconds)	Below 19°F
A100U45/30	4"	110	108	105	99	94	Do Not Test
A150U45/30	6"	170	167	162	153	145	Do Not Test
A200U45/30	8"	300	294	285	270	255	Do Not Test
A300U45/30	12"	400	392	380	360	340	Do Not Test
Sense Rotor							
Meter	Size	Above 59°F (seconds)	59°F to 50°F (seconds)	50°F to 40°F (seconds)	40°F to 30°F (seconds)	30°F to 19°F (seconds)	Below 19°F
A100U45/30	4"	200	196	190	180	170	Do Not Test
A150U45/30	6"	200	196	190	180	170	Do Not Test
A200U45/30	8"	300	294	285	270	255	Do Not Test
A300U45/30	12"	300	294	285	270	255	Do Not Test

6.6 Spin Test Record

6.6.1 Record the following items to document the spin test:

1. Test date.
2. Employee performing test.
3. Meter pressure.
4. Spin time.
5. Index reading.
6. Meter cartridge number.
7. Comparison to acceptable time for **PASS** or **FAIL** resultant.

UNCONTROLLED IF PRINTED

8. Any maintenance or corrective actions taken as a result of the test.

6.7 Accuracy Test

6.7.1 Perform the following activities to provide accurate test results:

1. Clean meter body and rotor assembly.
2. Lubricate bearings.
3. Run test on meter at a rate between 10% and 105% of the rated capacity.
4. Record accuracy test results.

6.7.2 For turbine meters equipped with a detachable rotor module, test module in either the service meter body or a test meter body.

6.8 Accuracy Test Record

6.8.1 Record the following items to document the accuracy test:

1. Test date.
2. Employee or contract service provider performing test.
3. Flow rates.
4. Accuracy test results.
5. Meter cartridge number.
6. Comparison to acceptable accuracy for **PASS** or **FAIL** resultant.

6.9 Follow-up Action

6.9.1 Check recorded spin time against the factory recommended times.

6.9.2 If spin time is not acceptable (i.e., equal to or greater than the minimum spin time specified by manufacturer), then correct the spin time by cleaning, lubricating, and/or repairing the meter.

6.9.3 Accuracy shall be within acceptable limits of $\pm 1\%$.

6.9.4 If necessary, schedule corrective maintenance activity or meter replacement.

6.10 Turbine Meter Records

6.10.1 Maintain turbine meter test results for life of the meter in MMS.

7.0 Ultrasonic Meter Testing

7.1 General

7.1.1 This procedure provides guidelines for periodically inspecting ultrasonic meters (USM's) and interrogating the associated instrumentation using meter manufacturer's application software to verify proper meter operation.

7.1.2 The *absolute digital time travel* (ADTT) measurement method is used for natural gas based on American Gas Association (AGA) Report No. 9 specifications for custody transfer flow measurement.

7.1.3 Ultrasonic meter parameters were developed by Gas Technology Institute (GTI) on device specific meter modules and spool piece for corrected gas velocity and speed of sound.

7.2 Ultrasonic Meter Inspection Schedule

UNCONTROLLED IF PRINTED

- 7.2.1 Periodically inspect and interrogate (using manufacturer's software) the ultrasonic meters installed as customer meters or the gas storage facilities injection/withdrawal meters at least every *3 months* to verify overall instrument operating condition.
- 7.2.2 At least 2 of the quarterly maintenance reports in a calendar year must be with gas flowing through the meter.
- 7.2.3 With gas flowing through the meter, use manufacturer's software to create a maintenance report that captures *at least 2 minutes of data*. The software uses the captured data to generate reports and graphs detailing the ultrasonic transducer's performance and the overall meter performance. Save the reports to document the current meter condition and to develop diagnostic benchmarks.
- 7.2.4 Perform all the following inspections:
 1. Path velocities.
 2. Gain levels.
 3. Gain limits.
 4. Performance percentage.
 5. Meter output frequency range.
 6. Speed of sound verification.
 7. Verification that the flow computer and USM have the correct settings, including:

Ultrasonic meter pulses represent actual cubic feet (ACF or acf) of flow through the meter.

- 7 a. Meter pulse uncorrected actual per cubic feet factor.
 - 7 b. Internal diameter of pipe.
 - 7 c. Validation of flow computer operation by independent calculation of corrected volume, thermal output, and meter adjustment factors.
- 7.2.5 If transducer performance (e.g., signal-to-noise ratio (SNR), gain values) change over time from the original installation or last inspection, it could be due to build-up of impurities on the transducer face. Take corrective actions per manufacturer's instructions.
- 7.2.6 Verify that the meter frequency output reflects the on-site flow computer frequency input.
- 7.2.7 Confirm that the on-site flow computer uses the same meter factor (pulses per actual cubic feet) as the USM.
- 7.2.8 Flow calibrate multi-path ultrasonic meters at least every *120 months*. Calibration of meter package shall include meter, flow conditioner, thermowells, and meter tubes.
 1. AIC may forego the 120-month flow calibration requirement IF:
 - 1 a. The periodic inspection documents can demonstrate that the meter meets manufacturer's tolerances, AND

UNCONTROLLED IF PRINTED

- 1 b. An internal inspection of the meter body performed at least every 120 months indicates that the meter has not accumulated internal deposits OR incurred other damage that would affect its accuracy

7.3 Transmitter Inspection

- 7.3.1 Verify all transmitters used in conjunction with flow computers for proper operation at least every *6 months*.
- 7.3.2 Verify electronic pressure and temperature transmitters for accuracy according to recommended procedures outlined by the transmitter manufacturer.
- 7.3.3 Verify that the transmitter signals (4 - 20 mA) reflect the corresponding input value to the on-site flow computer.
- 7.3.4 Confirm that the transmitter output scaling matches the on-site flow computer input.
- 7.3.5 Record the verification/inspection for accuracy and calibration adjustments on the AIC Gas Instrument Calibration Data Sheet.

7.4 Gas Chromatograph Operational Check

- 7.4.1 When an online gas chromatograph (GC) is used in the volume computation, verify GC is properly sampling the measured gas stream and that unit calibration is performed at a minimum programmed cycle at least once every 24 hours.
- 7.4.2 If a GC is used in measurement calculation at a natural gas storage facility and the facility is not injecting or withdrawing gas, then AIC may suspend its calibration until resuming injection or withdrawal operation.
- 7.4.3 Confirm that the GC is not in an alarm state or has any unacknowledged alarms.
- 7.4.4 Verify at least every *3 months* that the gas component un-normalized mole % variance is within $\pm 1.5\%$ of the gas contained within the calibration gas cylinder and that the values are being received at the meter and the on-site flow computer.
- 7.4.5 Request assistance if there are large differences in values.
- 7.4.6 Re-certify or replace the calibrated gas reference cylinder at least every *36 months*.

7.5 Inspection Records

- 7.5.1 Complete and save electronic versions of the Gas Instrument Calibration Data Sheets for pressure and temperature transmitters.
- 7.5.2 Save electronic copies of manufacturer's software generated maintenance and/or inspection reports plus software generated meter configuration files. Save maintenance logs and meter configuration files for *equipment life PLUS 3 years*.
- 7.5.3 Send electronic copies of above records to the Gas Meter Engineer - Decatur Central Meter Shop.
- 7.5.4 Maintain all meter configuration files plus calibration, inspection, and maintenance records on the USM SharePoint site or as a paper record for *5 years*.
- 7.5.5 For multi-path ultrasonic meters, maintain documents covering accuracy tests for *10 years*.

7.6 Follow Up Action

UNCONTROLLED IF PRINTED

- 7.6.1 If degradation of the ultrasonic transducer signal quality is noted, then take corrective action such as cleaning or replacing the transducer per manufacturer's instructions.
- 7.6.2 If pressure or temperature transmitter cannot be adjusted within the manufacturer's stated accuracy for span being used during calibration, replace the transmitter.
- 7.6.3 Inspect the physical properties of the meter run for abnormal operations.
- 7.6.4 As applicable, investigate, record findings of, and repair the following deficiencies:
 - 1. Atmospheric corrosion,
 - 2. UV degradation,
 - 3. Flange bolts,
 - 4. External wiring,
 - 5. Meter environment, AND
 - 6. Stresses.

8.0 Records and Retention

- 8.1 In summary (to above qualifications), file and retain all new inspection records in Click, Maximo, or OAS. However, some historical records may be retained in their paper form.
- 8.2 See the expanded and consolidated summary titled "Meter Test Schedules & Retention Requirements" located in [METR 4](#) under References. (in support of METR 2.2, 2.3, and 2.4).

End of Instructions.

Operator Qualification (OQ) Required?

YES

0201: Visual Inspection of Installed Pipe and Components for Mechanical Damage

0301: Manually Opening and Closing Valves

0381: Spring Loaded Pressure Regulating Device-Inspection and Testing, Preventive and Corrective Maintenance

0591: Leak Test at Operating Pressure

0641: Visually Inspect Pipe and Components Prior to Installation

0721: Joining of Pipe - Threaded Joints

0731: Joining of Pipe - Flange Assembly

0951: Installation of Pipe Above Ground

0961: Above Ground Supports and Anchors-Inspection, Preventive and Corrective Maintenance

1161: Installation of Meters and Regulators - Residential and Small Commercial

1171: Installing Meters - Large Commercial and Industrial

UNCONTROLLED IF PRINTED

1181: Installing and Maintaining Pressure Regulating, Limiting, and Relief Device - Large Commercial & Industrial

1191: Maintenance of Service Valves Upstream of Meter

1201: Temporary Isolation of Service Lines and Service Discontinuance

A001: Service Reconnect

A003: Emergency Response

Appendices

NONE.

Attachments

NONE.

Compliance Requirements

Illinois Commerce Commission (ICC) Title 83: Public Utilities, Part 501, Standards of Service for Gas Utilities and Alternative Gas Suppliers, specifically Subpart B: Natural Gas Measurement Requirements, available online [here](#).

Reference Documents

AIC Reference Form: Gas Instrument Calibration Data Sheet

[METR 1 Metering: Requirements](#)

[METR 2.2 Metering: Meter Inspection and Testing - Field](#)

[METR 2.3 Metering: Meter Inspection and Testing - Shop](#)

[METR 2.6 Metering: Pressure Gauges](#)

[METR 4 Metering: Forms and Reference Materials](#)

American Gas Association (AGA) Report No. 9, Measurement of Gas by Multipath Ultrasonic Meters, Latest Edition (Second Edition, April 2007)

Document Rescission

METR 2.4 Metering: Meter Inspection and Testing – GTS, October 1, 2021

Revision Notes

Location of Changes	Summary of Changes
HEADER	Added GCD
1.0 Purpose	Added – Gas Control and Dispatch (GCD)
3.0 Target Audience	Added: Gas Tech Services (GTS) Technicians Supervisor, Gas SCADA Gas Control Technicians (GCT) Removed: Gas Supervisors Gas Field Personnel

UNCONTROLLED IF PRINTED

Subsection 6.5 – Minimum Spin Times	Added Table 3: Sensus Auto-Adjust Turbine Meters – Spin Times
Paragraph 6.5.1	Added "Table 3"
Paragraph 7.3.4 – Transmitter Inspection	"transmitter" replaces "flow transmitter" – Confirm that the transmitter output scaling matches the on-site flow computer input.

METERING

October 1, 2022

METR 2.5 Gas Meter Bypass

1.0 Purpose

This document provides procedure for Ameren Illinois (AIC) to bypass the gas meter and to maintain customer's gas service when the normal supply is temporarily shut-off.

2.0 Scope

This document addresses the following:

[3.0 Target Audience](#)

[4.0 Basic Procedure](#)

[5.0 Using Portable CNG Tank System with Angled-System Bypass Valve](#)

[6.0 Using Portable CNG Tank with Grunsky Apparatus](#)

[7.0 Using Portable CNG Tank with the Mueller Briso Valve](#)

[8.0 Refilling Portable CNG Bottles](#)

3.0 Target Audience

- Gas Engineering
- Gas Supervisors
- Gas Field Personnel
- Gas Technical Services (GTS) Supervisor
- Gas Meter Supervisor

4.0 Basic Procedure

4.1 Bypassing meter can be used for the following situations:

4.1.1 Meter exchange.

4.1.2 Meter set repair or replacement.

4.1.3 Regulator repair or replacement.

4.1.4 Meter valve replacement.

4.1.5 Riser replacement.

4.1.6 Gas service line repair or renewal.

4.1.7 Local system pressure monitoring that involves a temporary meter removal.

4.2 Prior to touching gas meter set, check the following with "volt-stick" for possible voltage in accordance with [METR 2.2, Subsection 7.2](#) , AC Voltage on Meter Set:

4.2.1 Riser,

4.2.2 Meter, AND

4.2.3 Customer piping.

4.3 If possible, bypass operation should be done with little or no-load present. If the furnace is operating, consider waiting for it to cycle off to conserve CNG tank pressure.

UNCONTROLLED IF PRINTED

- 4.4 Use a portable CNG tank with a minimum of 600 psig to provide the bypass gas service.
- 4.5 Confirm customer delivery pressure.
 - 4.5.1 Use appropriate delivery pressure from the CNG tank system to ensure uninterrupted service.
 - 4.5.2 DO NOT overpressure customer fuel piping system with an incorrectly set delivery pressure from the CNG tank system.
- 4.6 All reconnected fittings shall be checked for leaks with leak detection fluid or leak detection instrument once gas service is restored.
- 4.7 Following restoration of service, observe the meter index for movement to ensure meter has returned to normal operation,

5.0 Using Portable CNG Tank System with Angled-System Bypass Valve

- 5.1 Crack open CNG bottle valve to purge air from feed line.
 - 5.1.1 Confirm that bottle delivery pressure matches the customer delivery pressure.
 - 5.1.2 Adjust CNG bottle pressure as necessary.
- 5.2 Remove plug fitting from the angled system bypass valve.
- 5.3 Connect CNG bottle hose fitting to the angled system bypass valve.
- 5.4 Loosely connect CNG bottle hose, open the CNG bottle hose valve to purge any remaining air, then tighten hose fitting.
- 5.5 Completely close the angled system bypass valve.
 - 5.5.1 Customer is now being supplied from CNG bottle.
 - 5.5.2 Monitor gauges at tank to ensure correct pressure to the customer is maintained throughout the process.
- 5.6 Meter set riser valve can be shut-off if needed.
- 5.7 To reinstate gas to customer:
 - 5.7.1 Ensure that meter set riser valve is completely opened, then completely open the angled system bypass valve to revert the customer back to metered distribution gas.
 - 5.7.2 Turn off the CNG tank bottle valve.
 - 5.7.3 Remove the CNG tank bottle hose and fitting.
 - 5.7.4 Replace the angled system bypass valve port plug.
 - 5.7.5 DO NOT lock the angled system bypass valve.

6.0 Using Portable CNG Tank with Grunsky Apparatus

- 6.1 Tee must be in proper alignment for CNG system to work.
- 6.2 Loosen plug on the tee being used; do not remove plug.
- 6.3 Place bag with correct size bayonet over tee. See Figure 1 for equipment picture.

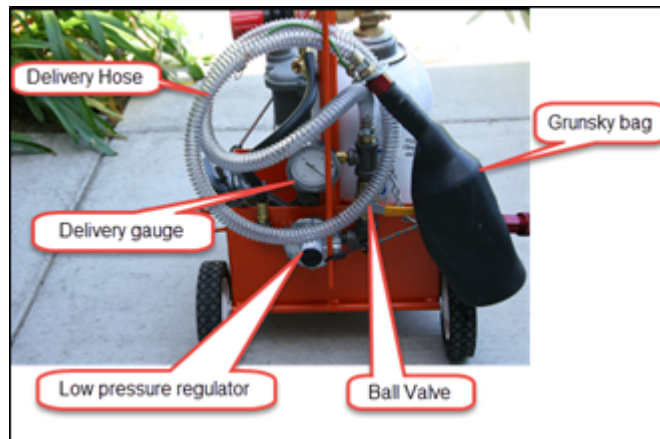

Figure 1: Grunsky Apparatus

- 6.4 Open main valve of the CNG tank and hose valve.
- 6.5 Open purge cap on the bag and squeeze bag to get air out.
- 6.6 Remove plug by squeezing bag and grasping plug; loosen with fingers and let plug drop into bag.
- 6.7 Force proper size bayonet into pipe through the tee, locking it with a twisting motion. No gas should be coming from the bag purge cap - signifying a good seal.
- 6.8 Monitor gauges at tank to ensure correct pressure to the customer is maintained throughout the process.
- 6.9 Meter set riser valve can be shut-off, if needed.
- 6.10 To reinstate gas to customer:
 - 6.10.1 With purge cap on bag open, back bayonet out of tee.
 - 6.10.2 Insert plug into tee and snugly tighten by hand. Bag to remain on the tee while replacing plug into tee.
 - 6.10.3 Shut off CNG tank and remove bag.
 - 6.10.4 Back off plug in the tee; do not remove; apply pipe dope to the plug and tighten with a wrench.

7.0 Using Portable CNG Tank System with the Mueller Brisco Valve

- 7.1 Crack open CNG bottle valve to purge air from feed line.
 - 7.1.1 Confirm that bottle delivery pressure matches the customer delivery pressure.
 - 7.1.2 Adjust CNG bottle pressure as necessary.
- 7.2 Remove the bypass plug fitting from the valve.
- 7.3 Connect CNG bottle hose fitting to the valve.
- 7.4 Loosely connect CNG bottle hose, open the CNG bottle hose valve to purge any remaining air, then tighten hose fitting.
- 7.5 Move lockwing 1/4 turn to allow bypass.

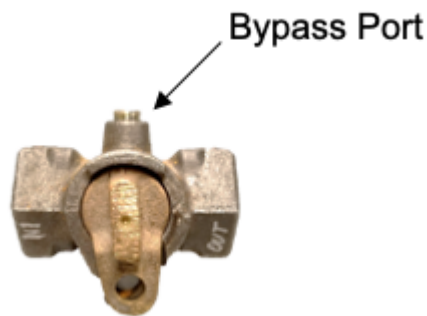

Figure 2: Brisco Valve in Bypass Position

- 7.5.1 Customer is now being supplied from CNG bottle.
- 7.5.2 Monitor gauges at tank to ensure correct pressure to the customer is maintained throughout the process.
- 7.6 Meter set riser valve can be shut-off if needed.
- 7.7 To reinstate gas to customer:
 - 7.7.1 Ensure that meter set riser valve is completely opened, then completely open the bypass valve to revert the customer back to metered distribution gas.



Figure 3: Brisco Valve in Normal Open Position

- 7.7.2 Turn off the CNG tank bottle valve.
- 7.7.3 Remove the CNG tank bottle hose and fitting.
- 7.7.4 Replace the angled system bypass valve port plug and inspect for leaks.
- 7.7.5 DO NOT lock the angled system bypass valve.

8.0 Refilling Portable CNG Bottles

- 8.1 When the small CNG bottle's pressure has reduced to 600 psig or below, the bottle should be refilled.
- 8.2 Locate the nearest CNG trailer, which are listed in **EMER 2.9 Subsection 5.0** and contact the Gas Technical Services (GTS) representative for that area.
 - 8.2.1 The CNG trailers should be used to refill the small CNG bottles, by trained GTS employees.
 - 8.2.2 The CNG trailers are pressurized to 3,600 psig and a regulator shall be used when filling the small CNG bottles to a maximum pressure of 2,000 psig.

In accordance with 49 CFR 173.6, the combined gross weight of all Materials of Trade must be less than 440 lbs. transported on any one vehicle.

8.3 Only qualified individuals should refill the small CNG bottles.

8.3.1 Locate the 3,600 PSIG port on the CNG trailer,

8.3.2 Ensure the trailer and small CNG bottle valve are closed,

8.3.3 Connect your hose and regulator assembly kit between the trailer port and threaded bottle connection. This assembly should include:

1. Ralston hose (QTQT-HOS-6ft). – 2 each
2. Concoa Series 493 Regulator.
3. Tee fitting with a valve in line purge.
4. Left-hand threaded connector for bypass tank outlet

8.3.4 Reset the regulator to ensure that outlet pressure does not exceed the maximum of 2,000 PSIG.

8.3.5 Slowly open the trailer valve to pressurize the line.

8.3.6 Set the regulator to the required outlet pressure.

8.3.7 Purge the pressurized line prior to opening the CNG bottle valve to ensure no air is introduced to the CNG bottle.

8.3.8 Slowly open the small CNG bottle valve and allow the pressures to equalize.

8.3.9 Once the bottle has reached its desired pressure, close the trailer and small CNG bottle valves.

8.3.10 Vent and disconnect the hose and regulator assembly.

End of Instructions.

Operator Qualification (OQ) Required?

YES

301: Manually Opening and Closing Valves

0591: Leak Test at Operating Pressure

0721: Joining of Pipe - Threaded Joints

0731: Joining of Pipe - Flange Assembly

0961: Above Ground Supports and Anchors-Inspection, Preventive and Corrective Maintenance

1161: Installation of Meters and Regulators - Residential and Small Commercial

1171: Installing Meters - Large Commercial and Industrial

1181: Installing and Maintaining Pressure Regulating, Limiting, and Relief Device - Large Commercial & Industrial

1191: Maintenance of Service Valves Upstream of Customer Meter

UNCONTROLLED IF PRINTED

A001: Service Reconnect

A003: Emergency Response

Appendices

NONE.

Attachments

NONE.

Compliance Requirements

NONE

Reference Documents

[METR 2.2 Metering: Meter Inspection and Testing - Field](#)

Document Rescission

METR 2.5 Metering – Gas Meter Bypass, April 1, 2021

Revision Notes

Location of Changes	Summary of Changes
2.0 Scope	Added Section 8.0 – Refilling Portable CNG Bottles
Section 8.0 Refilling Portable CNG Bottles	Operating instructions for refilling portable CNG bottles from CNG trailer by a qualified person.

METR 2.6 Pressure Gauges

1.0 Purpose

This document addresses the type or quality of pressure gauges that Ameren Illinois (AIC) uses in establishing and maintaining its high standards for measuring gas or regulating pressures throughout the distribution system. Also, it identifies requirements for periodically verifying the accuracy of the different category gauges.

2.0 Scope

This document addresses the following:

[3.0 Target Audience](#)

[4.0 General](#)

[5.0 Gauge Definitions](#)

[6.0 Use of Test Gauges](#)

[7.0 Use of Calibrating Gauges \(Portable Standard\)](#)

[8.0 Verification and Calibration](#)

[9.0 Reference Standard](#)

[10.0 Recordkeeping](#)

Appendices

[Appendix A - Gauge Accuracy Verification](#)

3.0 Target Audience

- Gas Engineering
- Gas Supervisors
- Gas Field Personnel
- Gas Technical Services (GTS) Supervisor
- Gas Meter Supervisor
- Gas Meter Shop Foreman

4.0 General

- 4.1 Certain activities require that a specific type of pressure gauge be utilized to ensure an adequate degree of accuracy for that task.
- 4.2 This procedure identifies when a test gauge or calibrating pressure gauge shall be used.
- 4.3 Pressure gauges used during construction and/or maintenance to establish or verify MAOP are addressed in [PTST 1, Section 8.0](#). Test Recording Methods.
- 4.4 All test and calibrating gauges shall be stored and transported in a protective case.
- 4.5 If a test or calibrating gauge is mishandled, dropped, or suspected of showing incorrect readings for any reason, it must be verified for accuracy.

5.0 Gauge Definitions

- 5.1 *Test Gauge* is a designated pressure gauge, ASME Grade 2A or 3A, with accuracy of at least $\pm 0.5\%$ full scale. It is periodically verified for accuracy and used for activities that require reading accuracy.
 - 5.1.1 A spring test gauge usually has features such as definitive zero, mirrored scale, knife-edged pointer, and a serial number.
 - 5.1.2 Face of a spring test gauge normally has "Test Gauge" printed on the face.
 - 5.1.3 A digital gauge that meets the minimum accuracy requirement can be used in lieu of a spring test gauge.
 - 5.1.4 Test gauges are entered and maintained in Maximo.
- 5.2 *Calibrating Gauge* (Aka "Portable Standard") is a designated pressure gauge with an accuracy of at least $\pm 0.10\%$ full scale, Grade 4A.
 - 5.2.1 A calibrating gauge can be used in the field to verify accuracy of an electronic pressure correcting device, calibrating pressure transducers, or in other situations where a high degree of accuracy is required.
- 5.3 *Portable Standards* mean instruments that can be used in the field or the meter shop to test the accuracy of auxiliary and tertiary equipment, transmitters, and other equipment associated with correcting a meter output.
- 5.4 *Reference Standards* mean instruments that are used only for verifying the accuracy of portable standards and whose accuracy is traceable back to the national standard as maintained by the National Institute of Standards and Technology (NIST) or its successor.

Reference Standards are for use in a shop environment only and never taken to the field.

6.0 Use of Test Gauges

- 6.1 "Zero" gauges prior to exposing them to the gas pressure.
- 6.2 Use a test gauge when performing the below activities. However, a calibrating gauge can also be used to perform these functions.
 - 6.2.1 Establishing regulator and relief valve set pressures at a new regulator station.
 - 6.2.2 Adjusting regulator and relief valve set pressures at all existing regulator stations.
 - 6.2.3 Verifying the pressure reading of permanently installed process gauges and pressure recording chart instruments.
 - 6.2.4 Verifying accuracy of process gauges used to record leak and/or strength test that verifies pipe/system MAOP.

7.0 Use of Calibrating Gauges (Portable Standard)

- 7.1 Use a calibrating gauge when performing the more sensitive tasks listed below.
 - 7.1.1 Establishing the regulator set pressure for all new customers metered at an elevated pressure (2 psig or greater).
 - 7.1.2 Performing the annual metering pressure verification for all commercial customers metered at an elevated pressure.

UNCONTROLLED IF PRINTED

- 7.1.3 Adjusting regulator operating pressures for all customers metered at an elevated pressure.
- 7.1.4 Verifying proper operation of electronic correctors, transmitters, other auxiliary and tertiary equipment connected to a meter, plus other equipment associated with correcting a meter output.

8.0 Verification and Calibration

8.1 Test Gauges

- 8.1.1 Verify each test gauge for accuracy once each calendar year, not to exceed 15 months.
- 8.1.2 Verify test gauge accuracy by comparing the test gauge reading to a calibrating test gauge or a dead weight tester at zero, half-scale, and full-scale readings.
- 8.1.3 For successful verification, the difference between gauge readings must be within its given tolerance, based upon the pressure range and accuracy of the test gauge.
- 8.1.4 For Ashcroft Model 1084 gauges, see [Appendix A](#) for the accuracy verification tolerances.
- 8.1.5 If the verification fails, the test gauge must have a 3-point calibration performed using a calibrating gauge or a dead-weight tester.

8.2 Calibrating Gauges

- 8.2.1 Each calibrating gauge shall be verified for accuracy against a certified reference standard at least every *12 months*.
- 8.2.2 For annual calibration/verification, the gauge may be done by a GTS person or sent to a 3rd party service.

9.0 Reference Standard

- 9.1 The reference standard shall be certified at least every *36 months* or by the certification due date.

10.0 Recordkeeping

- 10.1 The verification and calibration history for all test gauges, calibrating gauges, and reference standard shall be maintained in Maximo for *life of the gauge plus 3 years*.

End of Instructions.

Operator Qualification (OQ) Required?

YES

0301: Manually Opening and Closing Valves

0381: Spring Loaded Pressure Regulating Device-Inspection and Testing, Preventive and Corrective Maintenance

1161: Installation of Meters and Regulators - Residential and Small Commercial

1171: Installing Meters - Large Commercial and Industrial

1181: Installing and Maintaining Pressure Regulating, Limiting, and Relief Device - Large Commercial & Industrial

UNCONTROLLED IF PRINTED

A003: Emergency Response

Appendices

[Appendix A - Gauge Accuracy Verification](#)

Attachments

NONE.

Compliance Requirements

Illinois Commerce Commission (ICC) Title 83: Public Utilities, Part 501, Standards of Service for Gas Utilities and Alternative Gas Suppliers, specifically Subpart B: Natural Gas Measurement Requirements, available online [here](#).

Reference Documents

[METR 2.6 Metering: Pressure Gauges](#)

[METR 2.7 Metering: Gas Metering Corrections](#)

Document Rescission

METR 2.22 Metering: Pressure Gauges, January 1, 2018.

Revision Notes

Location of Changes	Summary of Changes
Not applicable.	This is a new document.

Appendix A - Gauge Accuracy Verification

Ashcroft Model 1084 Gauges		
Stock Code	Pressure Range	Verification Tolerance
49-22-443	0 - 15 psig	± 0.1 psig
49-22-444	0 - 30 psig	± 0.2 psig
49-22-445	0 - 60 psig	± 0.5 psig
49-22-446	0 - 100 psig	± 0.5 psig
61-12-288	0 - 160 psig	± 1.0 psig
49-22-447	0 - 200 psig	± 1.0 psig
49-22-448	0 - 300 psig	± 2.0 psig
49-22-449	0 - 400 psig	± 2.0 psig
49-22-450	0 - 600 psig	± 5.0 psig
49-22-451	0 - 1000 psig	± 5.0 psig

METERING

October 1, 2022

METR 2.7 Gas Metering Corrections**1.0 Purpose**

This procedure identifies electronic correcting equipment for accurate metering and billing of gas by Ameren Illinois (AIC), all in accordance with provisions established by the Illinois Commerce Commission (ICC). It includes installation, operations, and verification of such devices as a critical function in AIC gas metering operations.

2.0 Scope

This document addresses the following:

[3.0 Target Audience](#)[4.0 General](#)[5.0 Electronic Corrector New Installation, Field Exchange or Transfer Process](#)[6.0 Electronic Corrector Inspection-Verification Schedule](#)[7.0 Pressure Verification](#)[8.0 Temperature Verification](#)[9.0 AMI Reading Verification](#)[10.0 Gas Correcting Edits](#)[11.0 Maintenance Activities](#)[12.0 Atmospheric Corrosion Inspections / Follow-up](#)[13.0 Records](#)

Appendices

[Appendix A - Electronic Corrector Documentation](#)[Appendix B - Electronic Corrector Maintenance](#)[Appendix C - Electronic Corrector Verification Form](#)[Appendix D - Electronic Corrector Inspection Form](#)**3.0 Target Audience**

- Gas Engineering
- Gas Supervisors
- Gas Field Personnel
- Gas Technical Services (GTS) Supervisor
- Gas Meter Supervisor
- Gas Meter Shop Foreman
- IL Metering and Projects Supervisor
- Customer Accounts Department (CAD) Supervisor

4.0 General

- 4.1 An electronic corrector is typically selected and utilized for loads equal to or greater than 15,000 scfh; hence, large volume customers. It must be utilized in instances where the elevated metering pressure is greater than 15 psig.

UNCONTROLLED IF PRINTED

AIC's company use gas meters operating above 15 psig on January 01, 2017 shall be grandfathered and no electronic corrector is required.

- 4.2 This procedure identifies the requirement to periodically inspect/verify the proper operation of electronic correctors on meters to ensure that gas is measured accurately.
- 4.3 This addresses the requirements when an installation, with an elevated metering pressure, is subject to field actions regarding electronic correctors at customer premise as follows:
 - 4.3.1 Recently installed or addition.
 - 4.3.2 Changes.
 - 4.3.3 Removed.
 - 4.3.4 Billing constant changed on an account.

5.0 Electronic Corrector New Installation Field Exchange or Transfer Process

- 5.1 Gas Meter Shop and Gas Technical Services co-workers shall be responsible for programming electronic correctors.
 - 5.1.1 Gas Meter Shop co-workers will preconfigure gas meter/corrector/AMI assemblies for field installations.
 - 1. Verify the corrector parameters are correct for the gas meter combination.
 - 2. Save a copy of the Item File Report to the Gas Meter Data Sheet folder on the O:/drive
 - 5.1.2 Regional gas field personnel will verify the following items when installing a pre-configured assembly from the gas meter shop:
 - 1. Verify the pressure sensing line valve is "Open".
 - 2. Record meter reading and plug in the AMI module.
 - 3. Contact GTS Technician to verify the corrector is programmed and configured correctly if a corrector is transferred from one gas meter to another.
 - 5.1.3 GTS Technician shall complete the following activities:
 - 1. Device Programming Verification:
 - 1 a. Verify the electronic corrector programming for proper configuration to ensure measurement accuracy. Verify Item Codes to include:
 - a. Base Pressure (#3 – 14.73).
 - b. Atmospheric Pressure (#4 – 14.4).
 - c. % Specific Gravity (#53).
 - d. % N2 for Supercompressibility (#54).
 - e. % CO2 for Supercompressibility (#55).
 - f. Corrected Volume Units (#90 – MCF).

- g. Uncorrected Volume Units (#92 – CCF).
 - h. Ch. A Output (#93 CorVol Pulses).
 - i. Meter Index Rate (#98 – specific to meter).
 - j. Fixed Pressure Factor (#109 – 0 or Live)
 - k. Fixed Super Factor (#110 – 0 or Live)
 - l. Fixed Temp Factor (#111 – specific to TC on meter: "Live" if meter is non-TC with no temperature probe. If Temp is fixed, Item #1055 must be "No" and Item 1162 must be "60" on an EC630.).
 - m. Time (#203)
 - n. Date (#204)
 - o. Ch. A Pulse On/Off (#1041 should be Closed – 50 ms NS Open – 250+ ms).
 - p. Ch. A Pulse output (#1193 – 1000CF)
- 1 b. Verification of additional Item Codes may be relevant based upon the specific installation.
- 1 c. Device Installation Verification:
- a. Confirm device is installed properly on the meter or instrument drive.
 - b. Verify pressure sensing line valve is "Open".
 - c. Verify mechanical uncorrected dial index displays the correct units of measure and matches the electronic uncorrected.
- 1 d. Attach a copy of the Item File Report to the GMDS.

6.0 Electronic Corrector Inspection-Verification Schedule

- 6.1 Inspect and verify each new, exchanged, or transferred electronic corrector installed at a customer premise *within 60 days* for proper operation.
- 6.2 During the verification process, the activities and particulars outlined in [Appendix A](#) Electronic Corrector Documentation shall be documented on [Appendix C](#) Electronic Corrector Verification Form.
- 6.2.1 Where possible, a different co-worker than the one that originally completed the corrector installation or transfer should complete the follow-up verification.
- 6.3 Customer Service System (CSS) will automatically initiate the generation of an OAS order (MJ44) immediately after the corrector is installed on an account in CSS, or after being transferred to a gas meter at the premise based upon "set date".
- 6.4 Inspect and verify each electronic corrector installed at a meter installation at least *every 60 months* for proper operation.
- 6.5 The Gas Tech Services (GTS) Supervisor is responsible to schedule the inspections of electronic correctors.

7.0 Pressure Verification

- 7.1 Verify the electronic corrector pressure transducer for proper operation by comparing the corrector pressure reading to a calibrating gauge reading.

UNCONTROLLED IF PRINTED

- 7.1.1 The difference between the calibrating gauge pressure reading and the electronic corrector pressure reading must be within $\pm 1.0\%$. See the pressure verification equation ([Subsection 7.5](#)) that calculates the acceptable verification tolerance for each metering pressure.
- 7.1.2 The transducer pressure shall be verified at zero and flowing pressure.
- 7.2 In addition, verify the pressure transducer reading at zero-reference pressure (atmospheric pressure). If zero-reference pressure is greater than ± 0.2 psig, reset the zero-reference point to zero according to the manufacturer's procedures.
- 7.3 If pressure transducer cannot be verified for proper operation, schedule the electronic corrector for repair or replacement.

Due to the accuracy of electronic corrector pressure transducers, the calibrating gauge utilized for verification must have a full-scale accuracy range of $\pm 0.10\%$ or better.

- 7.4 Document the "As Found" and "As Left" pressure sensing valve position to the corrector.
- 7.5 Pressure Verification Equation.
 - 7.5.1 The equation below identifies the verification tolerance when comparing the electronic corrector pressure reading to a calibrating gauge reading.

$$\text{Metering Pressure} \times 0.01 = \text{Allowable Pressure Variance (Above or Below Metering Pressure)}$$

8.0 Temperature Verification

- 8.1 Verify the electronic corrector temperature transducer for proper operation by comparing the corrector reading to a temperature instrument.
 - 8.1.1 The difference between the temperature instrument and the electronic corrector reading must be within ± 2.5 °F.
 - 8.1.2 Verify temperature at 32 °F (ice bath).
 - 8.1.3 Also, verify temperature in one of 3 ways:
 1. At 75 °F,
 2. Flowing gas temperature, OR
 3. Temperature of gas at the meter.
- 8.2 If temperature transducer or the electronic corrector temperature reading cannot be verified for proper operation during either of these tests, schedule for repair or replacement.

9.0 AMI Reading Verification

- 9.1 Verify AMI (advanced metering infrastructure) reads are in alignment with field meter readings. See [Appendix A, Section A-7](#) for the verification process or [Appendix B, Section B-7](#) for the inspection process.

10.0 Gas Correcting Edits

UNCONTROLLED IF PRINTED

10.1 General

10.1.1 The Gas Correcting Edit process in CSS is intended to monitor the accuracy of electronic correcting devices installed on gas meters.

10.1.2 By proactively monitoring the accuracy of electronic correctors, AIC can maintain accurate metering for large volume accounts and detect events that might negatively impact gas revenues and require billing adjustments.

10.2 Electronic Correcting Device and CSS Setup

10.2.1 Set up electronic correcting devices to display the Corrected Usage, Pressure, and Temperature (when equipped).

10.2.2 Set up each account with an electronic correcting device in CSS to the appropriate "Meter Point Type," which depends on the type of correcting device.

10.2.3 Set up devices capable of correcting gas volumes for pressure only or for both pressure and temperature as "GasCorDev-Illinois".

10.3 Required Data Elements

10.3.1 The following data elements are required to complete the gas correcting edit process. These readings are normally gathered monthly by the meter reading system for each account.

1. Corrected index reading.
2. Uncorrected index reading.

10.3.2 For accounts with the "Meter Point Type" of "GasCorDev-Illinois," use pressure and temperature tables established in CSS to calculate the corrector edits with the corrected and uncorrected index readings provided from the meter.

1. Gas meter pressure.
2. Gas meter temperature.

Although most correcting devices are capable of correcting for temperature, the temperature correction may already be performed by the meter. For temperature compensated meters, correcting device temperature is programmed at a fixed value of 60 °F

10.3.3 The gas correcting edit calculations use the following:

1. Atmospheric pressure of 14.40 psig,
2. Base pressure of 14.73 psig, and
3. Base temperature of 60 °F.

10.4 Gas Correcting Edits Application

10.4.1 The automated gas correcting edits are performed after the monthly reading values are obtained for each account having an electronic gas correcting device installed.

10.5 Gas Correcting Edit Process

10.5.1 The "Meter Point Type" for each account identifies the expected reading types to be retrieved from field for the gas correcting edit calculations.

The process compares the calculated corrected usage (that is derived from the uncorrected readings, pressure, and temperature) versus the actual corrected usage value from the correcting device.

10.5.2 The calculated corrected usage should be:

1. Within $\pm 10\%$ of the corrected value for meters where gas pressure is regulated upstream of the meter, or
2. Within $\pm 30\%$ of the corrected value for meters where gas pressure is regulated downstream of the meter.

10.5.3 If the comparison of calculated corrected usage to the actual corrected usage exceeds the allowable criterion, billing is stopped for that account. This is a "Failed" edit. A CSS WFM is generated for a prompt investigation to be completed before initiating billing.

10.6 Follow-up Actions

10.6.1 Gas correcting edits that "Pass" are provided in a daily Vista "Passed Report" with edit details for review by:

1. Gas Operations and Services.
2. IL Metering and Projects.

10.6.2 Gas correcting edits that "Fail" are provided in a daily Vista "Failed Report" and a WFM is generated to be worked by Customer Accounts Department (CAD).

10.6.3 CAD to initially review account for any obvious meter reading or other data errors. If obvious errors are detected, the WFM can be overridden or CAD can request the meter be re-read. When new readings are obtained, the gas correcting edits are run on new readings to re-determine the pass or fail status.

10.6.4 CAD to create a Miscellaneous Gas Operations Support WFM for any failed edits that require a field investigation. Gas Tech Services investigates the problem and sends a Miscellaneous Customer Accounts WFM back to CAD with follow-up information from the investigation.

10.6.5 For gas correcting edits performed manually, any failed edits should follow a similar procedure. Upon notification of a failed edit, Gas Tech Services will perform an investigation and provide any follow-up information to CAD in case billing adjustments are necessary.

11.0 Maintenance Activities

11.1 When the electronic corrector inspection and verification process indicates a need for maintenance, then complete maintenance activities as outlined on [Appendix B](#) - Electronic Corrector Maintenance, and document the review/actions onto Electronic Corrector Inspection Form. See [Appendix D](#).

12.0 Atmospheric Corrosion Inspections / Follow-up

12.1 See [Appendix B, Section B-6](#), Atmospheric Corrosion Inspection.

- 12.2 Document in ClickMobile those gas metering facilities that have any corrosion control inspection activities marked (Y) for YES. Information will be transferred to Maximo for tracking and scheduling the required follow-up actions.
- 12.3 For required corrective action, follow the procedures identified in [CORR 1, Section 15.0](#), Atmospheric Corrosion. Maximo will track and maintain a record of corrective action.

13.0 Records

- 13.1 Complete the electronic corrector inspection order in OAS.
- 13.2 Document all the electronic corrector verification information on the Electronic Corrector Verification Form. See [Subsection 4.4](#) and [Appendix A](#). For form, see [Appendix C](#).
- 13.3 Document all electronic corrector inspection information on the Electronic Corrector Inspection Form. See [Subsection 10.1](#) and [Appendix B](#). For form, see [Appendix D](#).
- 13.4 The completed forms shall be reviewed by the GTS Supervisor and forwarded to IL Metering.
- 13.5 The inspection information shall be maintained for *10 years*.

End of Instructions.

Operator Qualification (OQ) Required?

YES

- 0191: Measure Atmospheric Corrosion
- 0301: Manually Opening and Closing Valves
- 0641: Visually Inspect Pipe and Components Prior to Installation
- 1161: Installation of Meters and Regulators - Residential and Small Commercial
- 1171: Installing Meters - Large Commercial and Industrial

Appendices

- [Appendix A - Electronic Corrector Documentation](#)
- [Appendix B - Electronic Corrector Maintenance](#)
- [Appendix C - Electronic Corrector Verification Form](#)
- [Appendix D - Electronic Corrector Inspection Form](#)

Attachments

NONE.

Compliance Requirements

Illinois Commerce Commission (ICC) Title 83: Public Utilities, Part 501, Standards of Service for Gas Utilities and Alternative Gas Suppliers, specifically Subpart B: Natural Gas Measurement Requirements, available online [here](#).

Reference Documents

- [CORR 1 Corrosion Control: Requirements](#)

Document Rescission

UNCONTROLLED IF PRINTED

METR 2.7 Metering: Gas Metering Corrections, October 1, 2020

Revision Notes

Location of Changes	Summary of Changes
2.0 Scope	New Section 5.0 Electronic Corrector New Installation, Field Exchange or Transfer Process Section 9.0 – AMI Reading Verification – Removed AMR
Form 4.4	Removed
Section 5.0 Electronic Corrector New Installation, Field Exchange or Transfer Process	New – Process identifies what tasks are to be performed by Gas Meter Shop personnel, Regional gas field personnel and GTS Technicians,
Subsection 6.2 – Electronic Corrector Inspection-Verification Process	New - During the verification process, the activities and particulars outlined in Appendix A Electronic Corrector Documentation shall be documented on Appendix C Electronic Corrector Verification Form.
Subsection 6.3	New - Customer Service System (CSS) will automatically initiate the generation of an OAS order (MJ44) immediately after the corrector is installed on an account in CSS, or after being transferred to a gas meter at the premise based upon "set date".
9.0 AMI Reading Verification	Removed AMR from title
9.1	Removed references to AMR.
Appendix A Electronic Corrector Documentation – A-1	Added "exchange" along with installation and transfer that require documentation.
A-3 Device Programming Verification	Added A-3.1.8 – Ch. A Output (#93 CorVol Pulses)
A-3 Device Programming Verification	Expanded A-3.1.12 - Fixed Temp Factor (#111 – specific to TC on meter "Live" if meter is non-TC with no temperature probe. If Temp is fixed, Item #1055 must be "No" and #1162 must be "60" on an EC350.)
A-3 Device Programming Verification	Added A-3.1.15 - Ch. A Pulse On/Off (#1014 should be Closed – 50 ms and Open – 250+ ms)
A-3 Device Programming Verification	Added A-3.1.16 - Ch. A Pulse output (#1193 – 1000 CF)
A-7 AMI Reading Verification	Removed AMR A-7.1 – Removed AMR A-7.2 - Removed AMR
Appendix B Electronic Corrector	Removed AMR B-7.1 – Removed AMR

UNCONTROLLED IF PRINTED

Maintenance – B-7	B-7.2 - Removed AMR
Appendix C – Electronic Corrector Verification Form	Update with April 27, 2022 version. AMI replaces AMR Under Device Programming- Added: 93 Ch. A Output 1014 Ch. A Pulse On/Off 1193 Ch. A Pulse output
Appendix D – Electronic Corrector Inspection Form	Updated with April 27, 2022 version. AMI replaces AMR Under Temperature Verification: Removed Temperature Simulator Tolerance Acceptable

Appendix A - Electronic Corrector Documentation

- A-1. *Requirement:* During the follow-up electronic corrector installation, exchange, or transfer verification process, complete the following activities and document on the Electronic Corrector Verification Form. See [Appendix C](#).
- A-2. *Meter Information:* Record the following items as indicated.
- A-2.1 Corrected Reading.
 - A-2.2 Electronic Uncorrected Reading.
 - A-2.3 Mechanical Uncorrected Reading.
 - A-2.4 Meter Index Reading - If available, record the uncorrected meter index reading.
 - A-2.5 Meter Number.
 - A-2.6 Meter Size - Record meter size.
 - A-2.7 Temperature Compensated box - Record Yes or No.
- A-3. *Device Programming Verification*
- A-3.1 Verify the electronic corrector programming for proper configuration to ensure measurement accuracy. Verify Item Codes to include:
 - A-3.1.1 Base Pressure (#13 - 14.73).
 - A-3.1.2 Atmospheric Pressure (#14 - 14.4).
 - A-3.1.3 % Specific Gravity (#53).
 - A-3.1.4 %N₂ for Supercompressibility (#54).
 - A-3.1.5 %CO₂ for Supercompressibility (#55).
 - A-3.1.6 Corrected Volume Units (#90 - MCF).
 - A-3.1.7 Uncorrected Volume Units (#92 - CCF).
 - A-3.1.8 Ch. A Output (#93 CorVol Pulses)
 - A-3.1.9 Meter Index Rate (#98 - specific to meter).
 - A-3.1.10 Fixed Pressure Factor (#109 - 0 or Live).

UNCONTROLLED IF PRINTED

A-3.1.11 Fixed Super Factor (#110 - 0 or Live).

A-3.1.12 Fixed Temp Factor (#111 - specific to TC on meter "Live" if meter is non-TC with no temperature probe. If Temp is fixed, Item #1055 must be "No" and #1162 must be "60" on an EC350.)

A-3.1.13 Time (#203).

A-3.1.14 Date (#204).

A-3.1.15 Ch. A Pulse On/Off (#1014 should be Closed – 50 ms and Open – 250+ ms).

A-3.1.16 Ch. A Pulse output (#1193 – 1000 CF).

A-3.2 Verifications of additional Item Codes may be relevant based upon the specific installation.

A-4. *Device Installation Verification*

A-4.1 Confirm device is installed properly on the meter or instrument drive.

A-4.2 Verify pressure sensing line valve is "Open."

A-4.3 Verify mechanical uncorrected dial index displays the correct units of measure and matches the electronic uncorrected read.

A-4.4 Verify additional items that may be relevant based upon the specific installation.

A-5. *Corrector Information*

A-5.1 Corrector Type - Record type or model.

A-5.2 Corrector Manufacturer.

A-5.3 Corrector Serial Number.

A-5.4 Alarms Displayed - Identify any alarms displayed & record the alarm type.

A-6. *Corrector Edit Calculation*

A-6.1 Verify proper operation of electronic corrector by completing a corrector edit when adequate usage has been registered by the corrector.

A-6.1.1 Edit is completed by comparing the corrected usage determined by the device to the calculated usage.

A-6.1.2 Calculated usage utilizes the raw uncorrected usage multiplied by the total correction factor from the device.

A-6.1.3 Difference should be less than 10% for gas metering installations where the gas is regulated upstream of meter.

A-6.1.4 Difference should be less than 30% for gas metering installations where gas is regulated downstream of meter.

A-7. *AMI Reading Verification*

A-7.1 Verify AMI reads are in alignment with field meter readings.

A-7.2 AMI readings lag field readings by 24-48 hours. The 7-day history function on the AMRC screen in OAS can be used to help determine alignment

A-8. *Follow-up Action/Remarks*

A-8.1 Record any follow-up actions or remarks that are applicable to complete the verification.

UNCONTROLLED IF PRINTED

- A-8.2 Communicate proper notification of potential billing adjustments to CAD (by the GTS Supervisor).

Appendix B - Electronic Corrector Maintenance

- B-1. *Requirement:* When the electronic corrector inspection process indicates a need for maintenance, then complete the below maintenance activities and document the review/actions onto Electronic Corrector Inspection Form. See [Appendix D](#).
- B-2. *Meter Maintenance:* Record the following items as indicated.
 - B-2.1 Corrected Reading.
 - B-2.2 Electronic Uncorrected Reading.
 - B-2.3 Mechanical Uncorrected Reading.
 - B-2.4 Meter Index Reading - If available, record the uncorrected meter index reading.
 - B-2.5 Meter Number.
 - B-2.6 Meter Size.
- B-3. *Corrector Maintenance:* Verify/Record the following items as indicated.
 - B-3.1 Corrector Type - Record type or model.
 - B-3.2 Corrector Manufacturer.
 - B-3.3 Alarms Displayed - Identify any alarms displayed & record the alarm type.
 - B-3.4 Corrector Date Set - Verify date is correct & reset if required (except Mini-P).
 - B-3.5 Corrector Time Set - Verify time is correct & reset if required (except Mini-P).
- B-4. *Battery Maintenance*
 - B-4.1 Main Battery Voltage - Record voltage. Replace battery pack or D-cell batteries if voltage is:
 - B-4.1.1 equal or less than 5.50 volts for the 9-volt replacement pack, or
 - B-4.1.2 equal or less than 4.30 volts for the 6-volt battery receptacle pack.
 - B-4.2 Wake Cycles (Lithium batteries) - Record the main battery wake cycles from Item #59. Replace battery if the wake cycles are:
 - B-4.2.1 greater than 10,000,000 cycles for an ECAT, or
 - B-4.2.2 greater than 40,000,000 cycles for a Mini-AT.
 - B-4.3 Main Battery Replaced - Record if replaced.
 - B-4.4 Memory Battery Voltage - Record the voltage from Item #51. Replace battery if the voltage is:
 - B-4.4.1 equal to or less than 2.10 volts for an ECAT, or
 - B-4.4.2 equal to or less than 3.60 volts for a Mini-AT.
 - B-4.5 Memory Battery Replaced - Record if replaced.
- B-5. *Follow-up Action/Remarks:*
 - B-5.1 Record any follow-up actions or remarks that are required to complete the inspection of the corrector.

B-5.2 Proper notification of potential billing adjustments shall be communicated to CAD by the GTS Supervisor.

B-6. *Atmospheric Corrosion Inspection*: Inspect the gas metering facilities for the following items and indicate (Yes/No).

B-6.1 Atmospheric corrosion (Y/N).

B-6.2 Disbonded coating (Y/N).

B-6.3 Needs paint (Y/N).

B-7. *AMI Reading Verification*

B-7.1 Verify AMI reads are in alignment with field meter readings.

B-7.2 AMI readings lag field readings by 24-48 hours. The 7-day history function on the AMRC screen in OAS can be used to help determine alignment.

Appendix C - Electronic Corrector Verification Form

[\(View/download PDF version\)](#)



April 27th 2022

Electronic Corrector Verification Form

General

Customer Name: _____
 Address: _____ Town: _____
 Date: _____
 Employee Name: _____ Supv. Review and Date _____

Meter Information

Meter Number: _____ Meter Size: _____ TC: yes no

Meter

Corrected Reading: _____ **AMI** Corrected Reading: _____
 Electronic Uncorrected Reading: _____ Uncorrected Reading: _____
 Mechanical Uncorrected Reading: _____ AMRC Reading Date: _____
 Meter Index Reading: _____

Device Programming

08. Gas Pressure: _____	13. Base Pressure: _____
14. Atmospheric Pressure: _____	26. Temperature: _____
53. % Specific Gravity: _____	54. %N2 for Supercomp.: _____
55. %CO2 for Supercomp.: _____	90. Corrected Volume Units: _____
92. Uncorrected Volume Units: _____	93. Ch. A Output CorVol Pulses _____
98. Meter Index Drive Rate: _____	109. Fixed or Live Pressure _____
110. Fixed or Live Super: _____	111. Fixed or Live Temperature: _____
203. Time: _____	204. Date: _____
1014. Ch.A Pulse On/Off _____	1193. Ch. A Pulse Output _____

Remarks: _____

Device Installation

Pressure Valve Open: yes no
 Device properly installed: yes no
 Mechanical Uncorrected Unit of Measure: _____

Corrector Information

Corrector Type: _____
 Corrector Manufacturer: _____
 Alarms Displayed on Arrival: yes no
 Alarm Type: _____

Corrector Edit

Corrected Usage = (Current Corrected Read-Previous Corrected Read) X 10 = _____
 Calculated Usage = (Current Uncorrected Read - Previous Uncorrected Read) X Correction Factor = _____
 % Difference = ((Recorded Usage - Calculated Usage)/Corrected Usage) X 100 = _____

Follow-up Action

CAD Notification Required yes no

Appendix D - Electronic Corrector Inspection Form

[\(View/download PDF version\)](#)



April 27th 2022

Electronic Corrector Inspection Form

General

Customer Name: _____
 Address: _____ Town: _____
 Date: _____
 Employee Name: _____ Supv. Review and Date _____

Meter Information

Meter Number: _____ Meter Size: _____ TC:yes no

Meter

Corrected Reading: _____ **AMI** Corrected Reading: _____
 Electronic Uncorrected Reading: _____ Uncorrected Reading: _____
 Mechanical Uncorrected Reading: _____ AMRC Reading Date: _____
 Meter Index Reading: _____

Pressure Verification

Allowable Pressure Variance = Meter Pressure X +/- 0.01

Corrector Pressure: _____ Test Gauge Pressure: _____ Zero Reference: _____
 Pressure Transducer Reset Zero Reference: yes no **As Found Pressure Valve Open** yes no
 Pressure Reading Tolerance Acceptable: yes no **As Left Pressure Valve Open** yes no
 Remarks: _____

Temperature Verification

Corrector Temperature: _____ Instrument Temperature _____ Corrector Temp: _____ Ice Bath (32Deg) _____
 Temperature Reading Tolerance Acceptable yes no
 Remarks: _____

Corrector

Corrector Type: _____ Corrector Number: _____
 Corrector Manufacturer: _____
 Alarms Displayed on Arrival: yes no Alarm Type: _____
 Corrector Date Set yes no
 Corrector Time Set yes no

Battery

Main Battery Voltage: _____
 Wake Cycles: _____
 Main Battery Replaced: yes no
 Memory Battery Voltage: _____
 Memory Battery Replaced: yes no

Corrosion Inspections *(If Yes, Document in Click Mobile)*

Atmospheric Corrosion yes no
 Disbonded Coating yes no
 Needs Paint yes no

Follow-up Action

CAD Notification Required yes no

Supersedes: October 1, 2021

METERING

October 1, 2021

METR 2.8 Pressure Factor Metering

1.0 Purpose

This document identifies the means of accounting for pressure on gas sales by applying fixed pressure factors or using electronic correcting equipment, all to provide accurate metering and billing of gas by Ameren Illinois (AIC) in accordance with provisions established by the Illinois Commerce Commission (ICC). It includes application considerations and implementation followed by process verification.

2.0 Scope

This document addresses the following:

[3.0 Target Audience](#)[4.0 General](#)[5.0 Elevated Metering Pressure Considerations](#)[6.0 Pressure Factor Metering](#)[7.0 Pressure Factors](#)[8.0 Electronic Correctors](#)[9.0 Verification Process](#)[10.0 Other Related Actions](#)[11.0 Records](#)**3.0 Target Audience**

- Gas Engineering
- Gas Supervisors
- Region Gas Engineer
- Gas Field Personnel
- Gas Technical Services (GTS) Supervisor
- Gas Meter Supervisor
- Gas Meter Shop Foreman
- Gas Operations and Services Supervisor
- IL Metering and Projects Supervisor
- Customer Accounts Department (CAD) Supervisor

4.0 General

- 4.1 Natural gas is normally measured at a standard metering pressure of 0.25 psig (7" w.c.).
- 4.2 Since natural gas is compressible, there is additional gas in each cubic foot at an elevated pressure. Therefore, the measured gas volume must be corrected for the elevated pressure effect when metered above the standard metering pressure.
- 4.3 The volume correction at elevated pressure may be accomplished by applying a pressure factor (billing constant) or using an electronic corrector.
- 4.4 Gas usage of larger volume customers may be measured more efficiently and economically by utilizing an elevated metering pressure.

UNCONTROLLED IF PRINTED

- 4.5 This procedure provides selection guidelines for determining when to use pressure factor metering or an electronic corrector for metering at pressures above the standard metering pressure.

5.0 Elevated Metering Pressure Considerations

- 5.1 Elevated metering pressure is typically provided to large-volume commercial and industrial gas customers when their equipment operates at higher pressure.
 - 5.1.1 AIC may also elect to use an elevated metering pressure in order to install a smaller, more economical meter.
- 5.2 When elevated metering pressure is used, the measured volume displayed on the meter index must be corrected for the additional gas volume in each cubic foot. The resultant is referred to as "corrected" volume.
- 5.3 A residential, commercial, or industrial customer may request a delivery pressure of 2 psig or greater.
 - 5.3.1 The elevated delivery pressure may be provided at AIC discretion based on customer's equipment requirements and AIC's available system pressure.
- 5.4 When a customer requests an elevated delivery pressure of 2 psig or greater, complete the Elevated Delivery Pressure Request Form (see [METR 4](#)).
 - 5.4.1 The customer must sign the form acknowledging the requested pressure.
- 5.5 Prior to approving an elevated metering pressure, Gas Engineering shall verify that the distribution system has enough pressure and capacity to meet the requested delivery requirements.
- 5.6 The Region Gas Engineer should select the lowest possible metering pressure based on the customer's requirements and a typical interior piping design. In addition, design the meter set piping configuration to prevent excessive pressure drop or pressure variation at meter outlet.

6.0 Pressure Factor Metering

- 6.1 First type of elevated metering pressure correction is using a pressure factor, which is subject to the following:
 - 6.1.1 Requires the gas be regulated at a constant pressure prior to entering meter.
 - 6.1.2 Volume of gas measured by the meter is multiplied by a pressure factor (referred to as billing constant in the CSS system) to calculate the corrected volume.
 - 6.1.3 Typically selected for loads less than 15,000 scfh.
 - 6.1.4 Can only be used on elevated metering pressure equal to or less than 15 psig.
 - 6.1.5 Company use gas meters operating above 15 psig on January 01, 2017 shall be grandfathered and installation of an electronic corrector is not required.

Regardless of load size and delivery pressure, pressure factor metering shall not be used at locations where distribution system capacity constraints do not allow a constant delivery pressure to be maintained through the meter.

- 6.2 The approved elevated pressures for pressure factor metering are 2 psig, 5 psig, 10 psig, and 15 psig.
- 6.3 When pressure factor metering is selected, the Region Gas Engineer specifies the meter and regulating equipment.
- 6.4 The regulator that is selected and sized for pressure factor metering must be capable of holding a constant outlet pressure to within $\pm 1.0\%$ of the absolute billing pressure under the anticipated load conditions.
 - 6.4.1 Adjust the regulator to the selected metering pressure with gas flowing.
 - 6.4.2 Attach a metal tag showing the elevated metering pressure, placing it in a visible location near the regulator or meter index.
 - 6.4.3 If a constant pressure cannot be maintained, evaluate installing a different regulator or an electronic corrector.
- 6.5 Use a calibrating gauge to set and verify the metering pressure on all new and existing pressure factor meter sets. See [METR 2.6, Section 5.0](#), Gauge Definitions.
- 6.6 See [Section 7.0](#) for the pressure factor corresponding to the approved elevated metering pressure,
- 6.7 Adjust the gas metering pressure if the "As Found" pressure is found to be greater than ± 0.25 psig from the expected pressure.

7.0 Pressure Factors

- 7.1 Calculate the pressure factors using the following formula:

$$Pf = (Pg + 14.40) / 14.73 \text{ psia}$$

Where:

Pf = Pressure Factor

Pg = Gauge Pressure (psig)

14.40 psia = Average Atmospheric Pressure

14.73 psia = Pressure Base

Table 1: Calculated Pressure Factors

Metering Pressure (psig)	Pressure Factor
2	1.113
5	1.317
10	1.656
15	1.996

8.0 Electronic Correctors

- 8.1 The second type of elevated metering pressure correction is installing an electronic corrector on the meter. The electronic correcting device continuously monitors the metering pressure. It automatically corrects the gas volume for the elevated pressure, flowing gas temperatures, and supercompressibility. Application of an electronic corrector is subject to the following:
 - 8.1.1 Gas flow does not have to be controlled at a constant pressure prior to entering the meter.

- 8.1.2 Typically selected for loads equal to or greater than 15,000 scfh.
- 8.1.3 Specifically used where the elevated metering pressure is greater than 15 psig; however, applications greater than 15 psig shall be approved by Gas Tech Engineering or IL Metering and Projects.
- 8.2 When an electronic corrector is selected, the Region Gas Engineer or Gas Tech Engineer will coordinate with IL Metering and Projects on reviewing and specifying the meter and regulating equipment to be used.
- 8.3 Any meter with metering pressure of 175 psig or greater shall be approved by Gas Tech Engineering and by IL Metering and Projects.

9.0 Verification Process

9.1 General

- 9.1.1 IL Metering and Projects will provide each Region and GTS with a list of gas meters that have a billing constant greater than 1.
 - 1. List to contain customer name, address, meter number, meter pressure, and billing constant.
 - 2. List will be generated annually prior to commencing the verification process that includes verifying CSS records for accuracy plus a site audit of metering pressure for each location.
- 9.1.2 Create investigation orders in OAS for all premises with a factor billed elevated meter pressure.

9.2 Pressure Factor Verification

- 9.2.1 Check the metering pressure for accuracy using a calibrating gauge at the meter outlet. See [METR 2.6, Section 5.0](#), Gauge Definitions.
- 9.2.2 Complete the metering pressure check with gas flowing through the meter. Flow may be due to normal customer operation or can be established by properly venting gas to atmosphere. Flow rate shall be less than 90% of meter capacity at the designated fixed-factor operating pressure.
- 9.2.3 Verify metering pressure at least every 36 months.
 - 1. If pressure check cannot be completed with gas flowing, identify the account as an incomplete verification and re-schedule the pressure check.
 - 2. If conditions that prevent meter verification are documented, verification may be delayed until those conditions cease to exist or for 4 months, whichever is shorter.
- 9.2.4 The employee completing the pressure check shall record the following:
 - 1. "As Found" pressure.
 - 2. "As Left" pressure.
 - 3. Pressure check date.
 - 4. Employee completing pressure check.
 - 5. Index reading.
 - 6. Additional remarks or comments.
 - 7. Any identified discrepancies that require follow-up action (enter under comments).

UNCONTROLLED IF PRINTED

8. Pressure tag installed on the meter (Y/N).

9.2.5 A physical check of gas metering pressure is not required per the pressure factor verification for the following:

1. Residential rate accounts that have an equal to or less than 5 psig metering pressure and have a meter with rated capacity under 700 cfh.
2. Non-residential rate accounts that have an equal to or less than 2 psig metering pressure and have a meter with rated capacity under 700 cfh.

9.3 Pressure Factor Verification with Recording Chart

9.3.1 The Gas Supervisor may determine that the metering pressure of certain customer accounts should be verified over an extended operating period.

9.3.2 This verification method can be done by installing a pressure recording chart (mechanical or electronic) typically for a period of 1-3 days.

9.3.3 The recorded pressure data is then averaged to determine if any adjustments to the metering pressure are required.

9.3.4 This pressure verification step is discretionary, but it should be done if believed that the existing regulator cannot maintain the metering pressure within $\pm 1/4$ psig.

9.4 Possible Billing Adjustments

9.4.1 Notify the Gas Supervisor if the physical check of metering pressure differs from the listed pressure by more than $\pm 1/4$ psig. The Gas Supervisor should verify the correct metering pressure and have the pressure adjusted accordingly by gas field personnel.

9.4.2 Any account on the CSS list that is identified with an incorrect metering pressure and/or billing constant shall be left "As Found" until the Gas Supervisor determines the required follow-up action.

There may have been a pressure change in the field that was not properly updated on the CSS account or the CSS record may be incorrect.

9.4.3 No pressure adjustments are required by the field personnel for metering locations with a mechanical or electronic correcting device. If the metering pressure is different than the listed pressure, it should be identified for follow-up action by the Gas Meter Supervisor.

10.0 Other Related Actions

10.1 The regulator that is used in conjunction with fixed factor billing shall be secured if it is discovered that the pressure setting has been tampering with. The regulator spring cap can be secured by means of installing a seal wire, where possible, or by other means. Twist wire seals are available through the Gas Meter Shop or MDF (Stock Code 62 55 093). Electric department wire seals are also acceptable.

10.2 AMR/AMI Reading Verification

10.2.1 Verify AMR/AMI reads are in alignment with field meter readings.

10.2.2 AMR/AMI readings lag field readings by 24-48 hours. Use the 7-day history function on the AMRC screen in OAS to help determine alignment of readings.

10.3 Corrosion Control Inspections

10.3.1 Complete corrosion control inspection activities on the gas metering facilities as follows:

1. Document atmospheric corrosion inspection in ClickMobile per [CORR 1, Section 15.0](#), Atmospheric Corrosion.
2. Document any disbonded coating and/or painting needs within ClickMobile if follow-up is required.
3. Transfer information to Maximo for scheduling and tracking of any required follow-up actions.

10.3.2 The corrective action work required will follow the procedures identified in [CORR 1, Section 15.0](#), Atmospheric Corrosion. Maximo will track and maintain a record of corrective action.

11.0 Records

11.1 The Gas Supervisor is responsible for reviewing the Gas Meter Data Sheet (GMDS) for pressure factor metering or when an electronic corrector is installed. (See [METR 2.10](#).) These records are required to perform the field verification of elevated metering pressure and to verify the associated pressure factor contained in CSS.

11.2 Distribute the GMDS to the appropriate individuals/departments as shown on the GMDS. (See [METR 2.10, Section 6.0](#), Report Distribution.)

11.3 Transfer any GMDSs that are completed on the paper form to the electronic form for distribution. (See [METR 4](#) for form.)

11.4 File completed Elevated Delivery Pressure Request forms at the Operating Center.

11.5 Retain all pressure factor verification records for 3 years.

End of Instructions.

Operator Qualification (OQ) Required?

YES

0191: Measure Atmospheric Corrosion

0301: Manually Opening and Closing Valves

0641: Visually Inspect Pipe and Components Prior to Installation

1161: Installation of Meters and Regulators - Residential and Small Commercial

1171: Installing Meters - Large Commercial and Industrial

Appendices

NONE.

Attachments

NONE.

Compliance Requirements

UNCONTROLLED IF PRINTED

Illinois Commerce Commission (ICC) Title 83: Public Utilities, Part 501, Standards of Service for Gas Utilities and Alternative Gas Suppliers, specifically Subpart B: Natural Gas Measurement Requirements, available online [here](#).

Reference Documents

[CORR 1 Corrosion Control: Requirements](#)

[METR 2.6 Metering: Pressure Gauges](#)

[METR 2.10 Metering: Gas Meter Data Sheet](#)

[METR 4 Metering: Forms and Reference Materials](#)

Document Rescission

METR 2.8 Metering: Pressure Factor Metering, April 1, 2021.

Revision Notes

Location of Changes	Summary of Changes
Paragraph 6.4.1	Change to – Adjust the regulator to the selected pressure setting with gas flowing.
Subsection 10.1	Moved language from Section 6.0 regarding the sealing of regulator spring cap on fixed factor metering if tampering with the pressure setting is discovered.

METERING

October 1, 2020

METR 2.9 Diaphragm Meter Repair

1.0 Purpose

This document addresses procedures and methods for repairing domestic diaphragm meters, other larger meters, and related equipment by Ameren Illinois (AIC), plus use of outside contract services, to ensure accurate and reliable gas measurement to the customers. All repairing is in accordance with code requirements of the Illinois Commerce Commission (ICC).

2.0 Scope

This document addresses the following:

[3.0 Target Audience](#)

[4.0 General](#)

[5.0 Meter Repair Procedures](#)

[6.0 Contract Meter Repair - General](#)

[7.0 Contract Meter Repair - Equipment](#)

[8.0 Contractor Repair Specifications](#)

[9.0 Other Terms and Conditions - Contracted Repairs](#)

[10.0 Contractor Quotations](#)

Appendices

[Appendix A - Domestic Meter "Class A" Repair - American & Rockwell](#)

[Appendix B - Domestic Meter "Class B" Repair:](#)

[Appendix B-1 - American & Rockwell Meters](#)

[Appendix B-2 - Sprague Meters](#)

3.0 Target Audience

- Gas Metering Supervisor
- Gas Meter Shop Foreman
- IL Metering and Projects Supervisor
- Purchasing Department

4.0 General

4.1 Criteria for category of diaphragm meter repair are as follows:

4.1.1 *"Class A" repair* is the less extensive repair level and typically involves meters that meet ALL the following criteria:

1. No more than 10 years old,
2. "In-test" average accuracy within +/- 1.5% (i.e., between 98.5% and 101.5%), and
3. Test accuracy spread within 1.2%.

4.1.2 *"Class B" repair* is more extensive repairs typically going beyond the bounds described above for Class A repair.

UNCONTROLLED IF PRINTED

- 4.2 For criteria and procedure for retiring meters, see [METR 2.1, Subsection 5.0](#), Meter Retirements. Some basic criteria for retiring meters include:
 - 4.2.1 Meters over 30 years old.
 - 4.2.2 Leaking diaphragm or tangent arms on diaphragm meters requiring replacement.
 - 4.2.3 Broken parts.
- 4.3 Gas meter contract testing and repair services include AIC gas meters, electronic correcting devices, and related proving equipment.
- 4.4 AIC may choose to utilize contract services to supplement the available AIC resources that perform meter repair and testing activities.
- 4.5 When logistically and economically practical, the meter or device manufacturer shall be utilized for testing and repair services.

5.0 Meter Repair Procedures

- 5.1 Class A Repair:
 - 5.1.1 American Domestic Meter - See [Appendix A](#)
 - 5.1.2 Rockwell Domestic Meter - See [Appendix A](#)
- 5.2 Class B Repair:
 - 5.2.1 American Domestic Meter - See [Appendix B-1](#)
 - 5.2.2 Rockwell Domestic Meter - See [Appendix B-1](#)
 - 5.2.3 Sprague Domestic Meter - See [Appendix B-2](#)

6.0 Contract Meter Repair - General

- 6.1 Contract services may be used for the following purposes:
 - 6.1.1 Repair and "adjust-testing" of diaphragm meters.
 - 6.1.2 Repair of rotary meters.
 - 6.1.3 Accuracy testing and repair of turbine meters.
 - 6.1.4 Re-certification of gas meter proving equipment to meet regulatory requirements.
 - 6.1.5 Repair and/or conversion of electronic correcting devices.
- 6.2 IL Metering and Projects is responsible for:
 - 6.2.1 Identifying suitable contract service providers to meet the respective testing and repair requirements, and
 - 6.2.2 Coordinating with Purchasing Department to secure quotations and award contracts.
- 6.3 Prospective bidders shall furnish a detailed list itemizing all parts and services included under each class and size of meter repair specified by AIC.
- 6.4 Contract testing and calibration of AIC gas meters and devices shall be performed by a contractor in compliance with all AIC procedures as well as Illinois Administrative Code Part 501.
- 6.5 When using a contract service provider, AIC will periodically conduct site inspections and monitor the work being performed on AIC meters (or devices) at the contractor's facilities for quality assurance.

7.0 Contract Meter Repair - Equipment

7.1 Diaphragm Meters

- 7.1.1 Adequate preparations shall be taken to protect diaphragm meters prior to being shipped to a contractor for repair.
- 7.1.2 Following in-testing by AIC, small and large capacity diaphragm meters (that are not retired) shall be prepared for shipping to a predetermined contract testing/repair facility. All meters will be picked up by contractor's freight service.
- 7.1.3 Shipping procedures:
1. Ship small diaphragm meters (425 cfh and smaller) in wire meter baskets, at least 30 meters per basket, with plywood (or OSB) separating the levels.
 2. Where baskets cannot be used, palletize 60 to 100 meters per 3 or 4 level pallets.
 3. Separate pallet levels with plywood (or OSB); shrink-wrap the entire pallet.
 4. Secure larger capacity meters (630 cfh and larger) as required to protect them during shipping.
 5. Multiple meters may be banded together or shrink-wrapped for shipping.
- 7.1.4 Contractor shall pick up all diaphragm meters from, and return them to, the respective AIC gas meter shop locations shown below. Contractor is responsible for returning the meters in the shipped baskets along with the plywood/OSB separators or properly packaged on pallets.

- AIC - Decatur Meter Shop
2655 N MLK Drive
Decatur, IL 62526
Attention: Gas Meter Supervisor

- AIC - Peoria Gas Meter Shop
7064 West US Highway 150
Edwards, Illinois 61528
Attention: Gas Meter Supervisor

7.2 Rotary Meters, Turbine Meters, and Gas Correcting Devices

- 7.2.1 The Gas Metering Supervisor of each meter shop is responsible for securing quotations and shipping instructions from the contractor for meter and equipment services needed and for returning rotary meters, turbine meters, and correcting devices that have been tested and/or repaired.

8.0 Contractor Repair Specifications

- 8.1 Where repairs to small diaphragm gas meters can be economically justified by contract services, AIC will specify the level of work to be done by the Contractor.
- 8.2 In aggregate, the meter maintenance, parts replacement, testing, and calibration activities that AIC believes are economically justified is defined as "Class B" repairs.
- 8.2.1 A Class B repair includes the following activities:
1. In-test (if required).
 2. Remove top.

3. Grind valves.
4. Replace worn pins, bushings, arms, and gears.
5. Replace top gaskets.
6. Test diaphragms for leaks and meter for internal leaks.
7. Pressure test the meter at case pressure to test for external leaks. AMR/AMI module, if equipped, shall be removed if the meter is to be submerged in water for test.
8. Check the index for excess dirt and free movement. Replace as necessary. Manufacturer specific index replacements are as follows:
 - 8 a. American meters - Replace indexes with holes or cotter pins in the "dog" drive. Replace all plastic indexes having black gears.
 - 8 b. Rockwell meters - Replace all plastic indexes having white gears.
 - 8 c. Sprague meters - Replace all indexes having 2 silver rivets and/or the "claw" type drive dog.
9. Prove or calibrate meter to within $\pm 1/2\%$ accuracy, with no more than a 1% spread between the check rate and capacity rate tests. Meters with an AMR/AMI device shall be tested or calibrated with the AMR/AMI module installed.
10. Sandblast, wheelbrute, or wire brush to give the meter a clean appearance.
11. Paint meters with AGA Standard #49 Gray. Cover all indexes during painting activity.

9.0 Other Terms and Conditions - Contracted Repairs

- 9.1 Small diaphragm meters (425 cfh and smaller), requiring more than a Class B repair to meet AIC specifications, shall be identified as "un-repairable" and retired at contractor's facility. See [Subsection 9.4](#) for handling and quality control procedure.
- 9.2 The AMR/AMI module on any meter retired by the contractor shall be returned to AIC.
- 9.3 Contractor shall submit detailed invoices showing the following:
 - 9.3.1 Complete breakdown of all applicable charges, including separate costs for labor and material.
 - 9.3.2 Additional parts required to complete large diaphragm meter repairs at the price identified in the contract quotation / specifications.
 - 9.3.3 "Credit" to AIC for each meter identified as "un-repairable" and retired at contractor's facility. Also, a list of retired meters by manufacturer, meter number, and reason for retiring the unit shall be furnished.
 - 9.3.4 Test results by both hard copy and electronic file (in a format readable by MMS) after the completion of each batch.
 - 9.3.5 Electronic copy of the programming (marriage) and MRB (divorce) files for all meters, where applicable.
- 9.4 Upon return of the repaired lot to AIC, a sample population based on the total number repaired will be pulled.
 - 9.4.1 The sample will be visually inspected and tested to ensure they have been repaired and adjusted to AIC specifications.

UNCONTROLLED IF PRINTED

- 9.4.2 If the sample fails (based on the tests performed on AIC provers), AIC will proceed with the following steps at our discretion.

Based on the results of the visual inspection and test results, Step 1 may be skipped and either Step 2 or 3 immediately executed.

- *Step 1:* AIC will pull a second sample for testing. If the second sample passes, the entire lot will be accepted. If the second sample fails, either Step 2 or 3 will be executed.
- *Step 2:* AIC will return the entire lot to the vendor for retesting, or
- *Step 3:* AIC will test 100% of the lot and adjust the meters as necessary at vendor's expense.

10.0 Contractor Quotations

- 10.1 The quoted prices for testing and repair services shall include, at a minimum, the following items:

- 10.1.1 Itemized prices for testing by meter class.
- 10.1.2 Standard repair parts by repair class
- 10.1.3 Additional non-standard repair parts by repair class.
- 10.1.4 Itemized cost for labor and materials.
- 10.1.5 Preparation of test results files.

End of Instructions.

Operator Qualification (OQ) Required?

NO.

Appendices

[Appendix A - Domestic Meter "Class A" Repair - American & Rockwell](#)

[Appendix B - Domestic Meter "Class B" Repair:](#)

[Appendix B-1 - American & Rockwell Meters](#)

[Appendix B-2 - Sprague Meters](#)

Attachments

NONE.

Compliance Requirements

Illinois Commerce Commission (ICC) Title 83: Public Utilities, Part 501, Standards of Service for Gas Utilities and Alternative Gas Suppliers, specifically Subpart B: Natural Gas Measurement Requirements, available online [here](#).

Reference Documents

[METR 2.1 Metering: Replacement and Retirement](#)

Document Rescission

UNCONTROLLED IF PRINTED

METR 2.10 Metering: Small Diaphragm Meter Repair, July 1, 2012.

METR 2.11 Metering: Contract Meter Repair, January 1, 2017.

Revision Notes

Location of Changes	Summary of Changes
Not applicable.	This is a new document.

Appendix A - Domestic Meter "Class A" Repair - American & Rockwell

"Class A" repair criteria: 1) ≤ 10 years old; 2) "In-test" average accuracy within $\pm 1.5\%$; AND 3) Test accuracy spread within 1.2%. See [Section 4.0](#).

There is no *"Class A" repair* for Sprague domestic meters

A-1. American & Rockwell Domestic Meters

Following is the procedure for *"Class A" repair* of both American and Rockwell domestic meters, with respective qualification inserted where applicable:

1. Verify the meter age.
 - A. If meter is 30 years old or more (based on meter badge information or MMS), retire meter.
 - B. Verify the meter badge is securely affixed to the meter and that the meter number is legible. Replace/repair if necessary.
2. If at any point more than 1 screw is broken while removing the index cover or hand-hole cover, retire meter.
3. Meters ≤ 8 years old, that are found to have manufacturers defects, should be returned to the manufacturer for warranty repair.
4. Index action:
 - A. For non-AMR/AMI meters, remove the index cover, gasket, and index. If the cover is a vented, tinted, Lexan-style and is in good shape, it may be reused. Dispose of gasket.
 - B. If the meter is AMR/AMI equipped, **do not remove** the AMR/AMI module unless it is damaged or found to be inoperable.
 - C. Check index for excess dirt and free movement.
 - D. Evaluate replacing index as follows:
 - (1) *American*: Replace indexes with holes or cotter pins in the "dog drive."
 - (2) *American*: Replace plastic indexes having black gears.
 - (3) *Rockwell*: Replace plastic indexes having white gears.

UNCONTROLLED IF PRINTED

5. Sandblast the meter, if necessary, to remove excess dirt or debris.
6. Remove hand-hole cover and discard gasket.
7. Blow out the meter with air and check internal mechanism, including tangent, arms, and wheel/gears. Verify that tangent arms are mounted in the correct position. See [Paragraph 4.2.2](#) regarding possible retirement.
8. Inspect adjustment nuts for looseness and inspect solder-point strength. Rotate tangent/arm assembly to check for "fluid" movement of arms and valves. *If meter inspection reveals a problem that requires a "Class B" repair, proceed to the Class B repair procedure.* See [Appendix B-1](#).
9. Sparingly oil tangent and arms.

Excess oil can attract valve dust and debris, impeding movement and registration.

10. Install the hand-hole cover using a new gasket.
 - A. Ensure a tamper screw is properly positioned to seal the index cover, or
 - B. Install a tamper plug cup if the hand-hole cover is not equipped with a tamper screw.
11. Clean spuds with wire wheel, brush, or rag.
12. Pressure test:
 - A. For non-AMR/AMI meters, pressure test the meter using the dry leak test (or dunk tank) to check for leaks.
 - B. For AMR/AMI meters, dry leak test at case pressure to check for leaks.
 - C. Leaks discovered through a dry leak test require the index or AMR/AMI module to be removed and additional leak testing (in dunk tank) to identify leak location. If a leak is found at a case gasket, replace gasket.
13. Clean the meter (or sandblast if necessary) to provide a clean surface for painting.
14. *For non-AMR/AMI meters:* install the index, new gasket, and cover. The old index may be re-used if in good shape (and not replaced in step 4).
 - A. If the current index cover is not the tinted, vented, Lexan-type cover; replace with a new cover and gasket.
 - B. Ensure a tamper screw is properly positioned to seal the hand-hole cover or install a tamper plug.
15. *For AMR/AMI equipped meters:* verify operation of the module by "busting it" to verify transmission and connecting to GPREP to verify the reading.
 - A. If difference between index and module readings is ≥ 4 , exchange the module.
 - B. If difference is ≤ 3 , reprogram the module.
 - C. Install the index (verifying proper movement), correct the module reading or exchange the module as necessary.
 - D. If the index has been replaced, reprogram the module with the new reading.

- E. Place a cover screw/tamper plug kit in the module and install cover.
16. Enter the repair in MMS.
17. Place the meter on a pallet/cart for adjust-testing.

Appendix B - Domestic Meter "Class B" Repair

"Class B" repair is more extensive repairs typically going beyond the bounds described for Class A in [Section 4.0](#).

B-1. American & Rockwell Domestic Meters

Following is the procedure for *"Class B" repair* of both American and Rockwell domestic meters, with respective qualification inserted where applicable:

1. Verify the meter age.
 - A. If meter is 30 years old or more (based on meter badge information or MMS), retire meter.
 - B. Verify the meter badge is securely affixed to the meter and that the meter number is legible. Replace/repair if necessary.
2. If at any point more than 1 screw is broken while removing the index cover, hand-hole cover, or meter top, retire meter.
3. Meters \leq 8 years old, that are found to have manufacturer's defects, should be returned to the manufacturer for warranty repair.
4. Index action:
 - A. For non-AMR/AMI meters, remove the index cover, gasket, and index. If the cover is a vented, tinted, Lexan-style and is in good shape, it may be reused. Dispose of gasket.
 - B. If the meter is AMR/AMI equipped:
 - (1) *American*: Do not remove the AMR/AMI module unless it is damaged or found to be inoperable.
 - (2) *Rockwell*: Remove AMR/AMI module and discard gasket.
 - C. Check index for excess dirt and free movement.
 - D. Evaluate replacing index as follows:
 - (1) *American*: Replace indexes with holes or cotter pins in the "dog drive."
 - (2) *American*: Replace plastic indexes having black gears.
 - (3) *Rockwell*: Replace plastic indexes having white gears.
5. Sandblast the meter, if necessary, to remove excess dirt or debris.
6. Remove hand-hole cover and discard gasket.
7. Remove the meter top and discard the gasket.
8. Check the tangent. Rotate the tangent arm assembly to check for "fluid" movement of arms and valves. Retire meter if it is worn or damaged and requires replacement.

UNCONTROLLED IF PRINTED

9. Inspect adjustment nuts and solder-joint strength.
10. Check diaphragms for leaks. If a diaphragm leak is discovered, retire meter.
11. Grind valves and valve seats. Reinstall valves on meter.
12. Replace worn pins, bushings, and plastic arms as needed. (Rockwell: Retire meter if metal arms are damaged that require replacement.)
13. *Rockwell*: Replace the port seal (exhaust washer).
14. Sparingly oil tangent and arms.

Excess oil can attract valve dust and debris, impeding movement and registration.

15. Inspect axle box seal and wheel. Replace if worn or damaged. Note (Rockwell): If the area around the seal appears green, remove the seal, grease area and re-install seal. Replace seal if it appears worn or damaged. Green discoloration around the seal is an indication of a leak.
16. Clean spuds with wire wheel, brush, or rag.
17. Install new top gasket and install meter top.
18. Install the hand-hole cover using a new gasket.
 - A. Ensure a tamper screw is properly positioned to seal the index cover, or
 - B. Install a tamper plug cup if the hand-hole cover is not equipped with a tamper screw.
19. Pressure test:
 - **American Meter**
 - A. For non-AMR/AMI meters, pressure test meter using the dry leak test (or dunk tank) to check for leaks.
 - B. For AMR/AMI meters, dry leak test at case pressure to check for leaks.
 - C. Leaks discovered through a dry leak test require the index or AMR/AMI module to be removed and additional leak testing (in dunk tank) to identify leak location. If a leak is found at a case gasket, replace gasket.
 - **Rockwell Meter**
 - A. Pressure test meter using the dunk tank to check for leaks.
20. Clean the meter (or sandblast if necessary) to provide a clean surface for painting.
21. For non-AMR/AMI meters; install the index, new gasket, and cover. The old index may be re-used if in good shape (and not replaced in step 4).
 - A. If the current index cover is not the tinted, vented, Lexan-style; replace with a new cover and gasket.
 - B. Ensure a tamper screw is properly positioned to seal the hand-hole cover or install a tamper plug.
22. For AMR/AMI equipped meters, verify operation of the module by "busting it" to verify transmission and connecting to GPREP to verify the reading.

UNCONTROLLED IF PRINTED

- A. If difference between index and module readings is ≥ 4 , exchange the module.
 - B. If difference is ≤ 3 , reprogram the module.
 - C. Install the module and index (verifying proper movement), correct the module reading or exchange the module as necessary.
 - D. If the index has been replaced, reprogram the module with the new reading.
 - E. Place a cover screw/tamper plug kit in the module and install cover.
23. Enter the repair in MMS.
24. Place the meter on a pallet/cart for adjust-testing.

B-2. Sprague Domestic Meters

Following is the procedure for "Class B" repair of the Sprague domestic meter:

- 1. Verify the meter age.
 - A. If meter is 30 years old or more (based on meter badge information or MMS), retire meter.
 - B. Verify the meter badge is securely affixed to the meter and that the meter number is legible. Replace/repair if necessary.
- 2. If at any point more than 1 screw is broken while removing the index cover or hand-hole cover, retire meter.
- 3. Meters ≤ 8 years old, that are found to have manufacturer's defects, should be returned to the manufacturer for warranty repair.
- 4. Index action:
 - A. Remove index cover, gasket, index, and AMR/AMI module (if equipped). Discard the gasket.
 - B. Check index for excess dirt and free movement.
 - C. Replace indexes that have 2 silver rivets or the "claw-type" drive dog.
- 5. Sandblast the meter, if necessary, to remove excess dirt or debris.
- 6. Remove meter top and discard gasket.
- 7. Check diaphragms for leaks. Retire meter if a diaphragm leak is discovered.
- 8. Check worm gear and index drive in the meter top for proper operation.
 - A. Replace worn or damaged parts.
 - B. If needed, replace the top if a spare is available.
 - C. Verify proper height of the valve with new top, if applicable.
- 9. Grind the valve and valve seat.
- 10. Remove pipe dope from adjustment screw hole and remove screw. Clean, replace, and tighten screw.
- 11. Reinstall valve on the meter.
- 12. Inspect IDM synthetic seal and replace if worn or damaged. Replace all "original" white seals (which tend to leak).

UNCONTROLLED IF PRINTED

13. Clean spuds with wire wheel, brush, or rag.
14. Replace top gasket and install meter top.
15. Pressure test the meter using the dunk tank to check for leaks. If a leak is found at the front or back case gasket, replace gasket.
16. Clean the meter (or sandblast if necessary) to provide a clean surface for painting.
17. For non-AMR/AMI meters, install the index (verify proper movement), new gasket, and cover. The old index may be re-used if in good shape (and not replaced in step 4).
 - A. If the current index cover is not the tinted, vented, Lexan-style; replace with a new cover and gasket.
 - B. Install 2 tamper seals.
18. For AMR/AMI equipped meters, verify operation of the module by "busting it" to verify transmission and connecting to GPREP to verify the reading.
 - A. If difference between index and module readings is ≥ 4 , exchange the module.
 - B. If difference is ≤ 3 , reprogram the module.
 - C. Install the module and index (verifying proper movement), correct the module reading or exchange the module as necessary.
 - D. If the index has been replaced, reprogram the module with the new reading.
 - E. Place a cover screw/tamper plug kit in the module and install cover.
19. Enter the repair in MMS.
20. Place the meter on a pallet/cart for adjust-testing.

End of Appendices

METERING

October 1, 2022

METR 2.10 Gas Meter Data Sheet**1.0 Purpose**

This procedure provides the instructions for completing and processing the Gas Meter Data Sheet (GMDS) to maintain accurate gas metering records on meter installations. Further, it outlines the verification process to follow for addressing elevated metering pressure facilities. The Sarbanes-Oxley Act of 2002 (SOX) is a federal law passed to help protect investors from fraudulent financial reporting by corporations. At AIC, impacted processes include meter reading and customer billing. Such controls require the GMDS gas meter data sheet to be compared to the account and the CSS WFM cleared within 90 days of the physical transaction.

The 90 days begins on the date of the physical transaction. This requirement makes it critical that every step of completing the orders and data entry are completed with urgency, accuracy, and in a timely fashion.

2.0 Scope

This document addresses the following:

[**3.0 Target Audience**](#)[**4.0 Gas Meter Data Sheet**](#)[**5.0 Completion Instructions**](#)[**6.0 Report Distribution**](#)[**7.0 Gas Metering Review WFM**](#)

Appendices

[**Appendix A - GMDS Completion Instructions**](#)[**Appendix B - Gas Meter Data Sheet**](#)**3.0 Target Audience**

- Gas Engineering
- Gas Field Personnel
- Gas Technical Services (GTS) Supervisor
- Supervisor Illinois Meter Shops
- Gas Meter Shop Foreman
- Gas Supervisor
- IL Metering and Projects Supervisor
- IL Customer Accounts
- IL GTClerical

4.0 Gas Meter Data Sheet

4.1 The Gas Meter Data Sheet (GMDS) is a comprehensive document intended to capture all pertinent information for an elevated metering pressure installation that is added, re-

UNCONTROLLED IF PRINTED

moved, or changed in the field. See [Section 5.0](#) and the [Appendix A](#) for instructions to complete the form.

4.1.1 This information is also maintained and utilized for weekly metering verification and pressure factor verification process that is performed annually. See [METR 2.8](#) Pressure Factor Metering

4.2 Gas field personnel shall accurately complete the GMDS for any of the following:

4.2.1 A gas meter set that operates at an elevated metering pressure (greater than 12" w.c.) and is:

1. Installed
2. Exchanged
3. Removed

4.2.2 Elevated metering pressure is increased or decreased, such as:

1. Increase from 7" w.c. to 2 psig
2. Decrease from 5 psig to 2 psig, etc.

4.2.3 Electronic corrector is:

1. Installed
2. Exchanged
3. Removed

4.2.4 Meter Index is changed on any meter with elevated metering pressure.

4.2.5 Data corrections for adjusting metering pressure error and corresponding billing constants in Customer Service System (CSS).

4.2.6 A regulator or relief valve on a meter set operating at an elevated pressure is:

1. Installed
2. Exchanged
3. Modified, i.e., changes in metering or delivery pressure settings

A GMDS is not required when exchanging a regulator and/or relief valve with a "like kind" which does not affect billing accuracy.
Example: Replacing failed 289H relief valve with another relief valve that has the same set pressures as the failed 289H.

4.3 Modifying programming parameters on an electronic corrector that could affect billing adjustments.

4.3.1 Adjusting the pulse output to an AMI module, OR

4.3.2 Change to meter drive rate, etc

4.4 This procedure is not applicable to ultra-sonic meters (USM) installed at a customer's premise.

5.0 Completion Instructions

UNCONTROLLED IF PRINTED

- 5.1 Gas field personnel should check the appropriate option at top of GMDS (form) that describes the need for processing the form. See added qualifications in [Appendix A, Section A-1](#).
- 5.2 While at the customer's premise, applicable pictures will be taken **and** attached to the GMDS including:
 - 5.2.1 Gas meter serial number badge.
 - 5.2.2 Gas meter index.
 - 5.2.3 Pressure gauge reading, if applicable.
 - 5.2.4 Corrector serial number badge.
 - 5.2.5 Corrector item file, if applicable.
 - 5.2.6 Any other appropriate pictures, such as corrected and uncorrected meter readings.
- 5.3 See the following appendices for guidance on completing the GMDS:
 - 5.3.1 [Appendix A](#) - Provides numbered instructions as synchronized references for entering/completing respective items on the GMDS report.
 - 5.3.2 [Appendix B](#) - Shows an open GMDS (form) with tracking numbers in response or data boxes as linked to the numbered instructions outlined in Appendix A.

6.0 Report Distribution

- 6.1 After supervisor approval, a copy of each completed GMDS will be forwarded electronically to the appropriate co-workers/department. An email alert will be sent from ILGMD-SALERT. The GMDS Teams App will automatically route the completed GMDS to the appropriate co-workers/department.
- 6.2 Send GMDS copy electronically to IL Customer Accounts (IL CAD) @PeoriaGasTransportation or MO Customer Accounts (MO CAD) @DLMV90GasMO when the Teams App is not available and:
 - 6.2.1 There are potential billing adjustments,
 - 6.2.2 Account is a gas transportation customer, OR
 - 6.2.3 Meter has a corrector added.
- 6.3 Send GMDS copy on 11M and larger meter installs, exchanges, and removals to @ILGTClerical.

7.0 Gas Metering Review WFM

- 7.1 To facilitate data verification of installations that have an elevated metering pressure, a batch query will run in CSS each week. This query will identify accounts that have had any changes performed in the field and create a "Gas Metering Review Required" WFM (Workflow Manager software). See Table 1.

Table 1: Gas Metering Verification Review

	With Correcting Device	Using Pressure Factor > 1
New Meter Installed	√	√
Meter Exchanged	√	√
Pressure Method Changed	Removed Service - Switched to Constant Pressure Factor	Switched to Correcting Device

UNCONTROLLED IF PRINTED

Exchanged	√	Pressure Change
Removed Meter	√	√
Other		See Note 1.
Note 1: When a CMO to self has been detected on a meter requiring a correcting device.		

- 7.2 The Supervisor Illinois Meter Shops is responsible for completing the "Gas Metering Review Required" WFM. Complete the WFM by verifying that information on the GMDS is consistent with information contained in CSS. The data verification shall include:
 - 7.2.1 Meter point type.
 - 7.2.2 Pressure.
 - 7.2.3 Pressure factor.
 - 7.2.4 Billing constant.
 - 7.2.5 Meter readings.
 - 7.2.6 Number of dials.
- 7.3 Any discrepancies between the GMDS and CSS must be investigated with the appropriate Regional or GTS supervision to identify the appropriate corrective action. All corrections should be completed in CSS and on the GMDS before the WFM is completed in CSS.
- 7.4 Gas Meter Multiplier Changed WFM
 - 7.4.1 The CSS billing constant for most customer accounts typically does not change once established. However, the billing constant is susceptible to being changed unknowingly when completing an OAS order or by someone performing account maintenance. To detect possible billing errors, create a "Gas Meter Multiplier Changed" WFM when a billing constant is changed in CSS.
 - 7.4.2 The Supervisor Illinois Meter Shops is responsible for completing the "Gas Meter Multiplier Changed" WFM. Complete by verifying the correct metering pressure and associated billing constant. If an error is found, send a Miscellaneous WFM to the appropriate Region or GTS Supervisor with detailed instructions identifying the corrective action. Complete all corrections in CSS and on the GMDS before the "Meter Multiplier Changed" WFM is completed in CSS.

End of Instructions.

Operator Qualification (OQ) Required?

YES

- 0201: Visual Inspection of Installed Pipe and Components for Mechanical Damage
- 0301: Manually Opening and Closing Valves
- 0641: Visually Inspect Pipe and Components Prior to Installation
- 1161: Installation of Meters and Regulators - Residential and Small Commercial
- 1171: Installing Meters - Large Commercial and Industrial

UNCONTROLLED IF PRINTED

1181: Installing and Maintaining Pressure Regulating, Limiting, and Relief Device - Large Commercial & Industrial

1201: Temporary Isolation of Service Lines and Service Discontinuance

A001: Service Reconnect

A003: Emergency Response

Appendices

[Appendix A - GMDS Completion Instructions](#)

[Appendix B - Gas Meter Data Sheet](#) (2 pages)

Attachments

NONE.

Compliance Requirements

Illinois Commerce Commission (ICC) Title 83: Public Utilities, Part 501, Standards of Service for Gas Utilities and Alternative Gas Suppliers, specifically Subpart B: Natural Gas Measurement Requirements, available online [here](#).

Reference Documents

[METR 2.7 Metering: Gas Metering Corrections](#)

[METR 2.8 Metering: Pressure Factoring Metering](#)

Document Rescission

METR 2.10 Metering – Gas Meter Data Sheet, October 1, 2021

Revision Notes

Location of Changes	Summary of Changes
Paragraph 4.1.1	New - This information is also maintained and utilized for weekly metering verification and pressure factor verification process that is performed annually. See METR 2.8 Pressure Factor Metering
Paragraph 4.2.1 Complete GMDS for the following	Changed to metering pressure greater than 12" w.c.
Paragraph 4.2.2 Complete GMDS for the following	Updated - Elevated metering pressure is increased or decreased, such as: 2. Decrease from 5 psig to 2 psig
Paragraph 4.2.5 Data Corrections	Consolidated information - Data corrections for adjusting metering pressure error and corresponding billing constants in Customer Service System (CSS)
Paragraph 4.2.6 Complete GMDS for the following	Deleted "Removed" – GMDS not required when regulator and/or relief valve is removed. Updated: Modified, i.e. changes in metering or delivery pressure settings

UNCONTROLLED IF PRINTED

Paragraph 4.2.6 Complete GMDS for the following	Added NOTE: A GMDS is not required exchanging a regulator and/or relief valve with a "like kind" which does not affect billing accuracy.
Former Subsec- tions 4.3 & 4.4	Removed- Information relocated.
Subsection 4.3	Modifying programming parameters on an electronic corrector that could affect billing adjustments. 4.3.1 Adjusting the pulse output to an AMI module, OR 4.3.2 Change to meter drive rate, etc.
Subsection 4.4	This procedure is not applicable to ultra-sonic meters (USM) installed at a customer's premise.
Subsection 5.2 Completion In- structions – applic- able pictures	Grammatical correction – "and" replaced "too"
Paragraph 5.2.3	Added – "if applicable"
Paragraph 5.2.5	New – Corrector item file, if applicable
Paragraph 5.2.6	Added – such as corrected and uncorrected meter readings
Subsection 6.2 – Report Distribution	Added – when Teams App is not available and:
Subsection 6.3	Removed – and @IL Cust Service Key Account
Appendix A – GMDS Completion Instructions – A-3.5	Added - Also, attach all of the required pictures to the electronic GMDS for the work performed

Appendix A - GMDS Completion Instructions

A-1. General

A-1.1 At top of the GMDS, gas field personnel should check 1 of the 5 options which best describe why the GMDS is being completed.

A.1.1.1 If the choice checked is "Other" provide an explanation in Remarks section on back of the form.

A-1.2 The instructions below are numbered items as synchronized references to an open GMDS (form) with tracking numbers in the response or data entry boxes. See "number flagged" GMDS in [Appendix B](#).

A-2. Installation Information

A-2.1 General Customer Information

1. Date: Enter meter installed or turned on date.
2. Meter #: Enter the 8-digit manufacturer serial number shown on the nameplate or badge. Enter leading "zeros" if the manufacturer's serial number on

UNCONTROLLED IF PRINTED

the meter is less than 8 characters. For legacy CILCO meters, the AIC meter number may be entered, for reference, in the Remarks section on the back of form.

3. CRTS#: Enter the Construction Request Tracking System number provided for gas metering projects from customer related work requests.
4. Legacy Company/Rate Zone: Check the appropriate legacy company or rate zone for the operating area where the customer is located.
5. Action/Reason: Check 1 of the 5 options which best describes why the GMDS is being completed.
6. Customer: Enter customer name.
7. Address: Enter address where gas service is being furnished.
8. OAS#: Enter OAS order number, if applicable.
9. City: Enter the city (town) where the customer is located.
10. Employee Name/ID: Enter the employee name completing the customer order or performing the work.
11. Laptop/Asset#: Enter the company laptop/asset number for the device used to complete any programming or downloading data.
12. Employee Phone#: Enter a phone number where the employee completing the GMDS can be contacted for any necessary follow-up.

A-2.2 Installation Information

13. Meter Size: Enter the actual gas meter size from the meter badge (e.g., 16M175 TC, AL-800).
14. Meter Code: Enter the 5-digit gas meter code (e.g., meter code for 16M175 TC meter is 04361). A listing of gas meter codes is available from the Gas Metering Supervisor.
15. Customer Classification: Mark the appropriate rate class for customer.
16. By-Pass: Identify if the meter installation has a bypass installed; check "Yes" or "No".
17. Meter Drive: Enter the cubic feet per revolution for the meter index test hand that identifies the volume of gas passing through meter each time the test hand completes 1 revolution. Many meters have multiple test hands; so, choose the largest drive-rate value. Mark the appropriate value which will generally be 1 ft, 2 ft, 5 ft, 10 ft, 100 ft, or 1000 ft.
18. Meter temperature compensation: Enter TC or Non-TC.
19. Gas Transportation Customer: Identify if the meter installation is for a gas transportation customer account; check "Yes" or "No".
20. Test Plugs: Identify if test plugs are installed; check "Yes" or "No".
21. Meter Left: Indicate the "As Left" status of meter when leaving site.

A-2.3 Pressure Factor Information (No Corrector/Corrector Removed)

22. Meter Pressure: Enter the approved elevated metering pressure established for the installation. Standard elevated metering pressures for new installa-

tions are 2 psig, 5 psig, 10 psig, and 15 psig. The pressure should be identified and/or verified with a calibrating gauge.

23. Meter Reading: Enter the meter index reading - enter as "right justified" with leading zeros. If no meter index, note such in Remarks section on back of form, or enter "N/A" in the reading field.
24. Meter Pressure Tagged: Identify if the meter has either a stainless steel or brass pressure tag attached; check "Yes" or "No".
25. Number of Dials: Identify the number of dials on the meter index; the number of dials does not include the test hand(s). Check the number of dials, typically 4, 5, or 6.

A-2.4 Auxiliary Equipment Information

26. Manufacturer: Enter the manufacturer of auxiliary equipment being installed (e.g., Mercury, American).
27. Serial Number: Enter the manufacturer's serial number of the auxiliary equipment.
28. Model Type: Enter the auxiliary equipment model type (e.g., Mini-AT100).
29. Meter Pressure: Enter the approved elevated metering pressure established for the installation. Pressure should be identified and/or verified with a calibrating gauge. The pressure should match the pressure displayed on corrector within ± 0.5 psig.
30. Pressure Transducer Range: Enter the pressure range for the pressure transducer that is installed in the correcting device (e.g., 0 - 100 psig, 0 - 60 psig).
31. Programmed Unit of Measure: Enter the unit of gas measurement as programmed into the correcting device. It is generally programmed to display in hundreds of cubic feet (CCF) or thousands of cubic feet (MCF). Therefore, check the appropriate value which is "CCF (100)" or "MCF (1000)".
32. Corrected Reading: Enter the corrected meter reading from the LCD display of the electronic correcting device. Enter reading as "right justified" with leading zeros and a maximum of 6 digits.
33. Corrected Reading Multiplier: Identify the corrected reading multiplier (aka CSS billing constant). The corrected reading multiplier will correspond to the programmed unit of measure for the corrector (see item #29). If the programmed unit of measure is CCF, the corrected reading multiplier will be "1". If programmed unit of measure is MCF, the corrected reading multiplier will be "10". Check the appropriate value; "1" or "10".
34. Uncorrected Reading: Enter uncorrected meter reading from LCD display of the electronic correcting device. Enter reading as "right justified" with leading zeros and a maximum of 6 digits.
35. Instrument Base Mechanical Reading: Enter the uncorrected mechanical reading found at the base of correcting device.
36. Rotary Meter Index Reading: Enter rotary meter index reading for rotary meter installations.
37. Time of Day: Enter the time and check "am" or "pm" corresponding to data downloads.

UNCONTROLLED IF PRINTED

38. LAN ID: Enter 8 characters with leading zeroes, as necessary.
39. Site ID #1: Enter the #1 site ID from the auxiliary equipment (Item 200 programmed with corrector serial number). Note: completely fill each field with 8 digits using leading zeros.
40. Site ID #2: Enter the #2 site ID from the auxiliary equipment (Item 201 programmed with the meter number). Note: completely fill each field with 8 digits using leading zeros.
41. Device Baud Rate: Check the appropriate baud rate for the installed auxiliary equipment.
42. Device Phone #: Enter the phone number necessary to communicate with auxiliary equipment.

A-2.5 Meter Set Regulator/Relief Information

The regulator and relief valve portion of form is to identify the basic equipment for elevated pressure metering installations. Additional information about the regulator and relief equipment may be provided in Remarks section.

43. Regulator Location(s): Identify the locations of all regulators associated with the meter installation. Check all that apply.
44. Regulator Model: Enter the regulator model number (e.g., Fisher 99).
45. Regulator Type: Identify the regulator type; check one.
46. Regulator Body Size: Enter the regulator body size.
47. Orifice Size/Trim Size: Enter the regulator orifice/trim size.
48. Spring Color/Range: Enter the regulator spring range and color.
49. Regulator Set Point: Enter the regulator set point.
50. Relief Model: Enter the relief valve model number (e.g., Fisher 63 EG).
51. Relief Size: Enter the relief valve body size.
52. Delivery Pressure ?: Check if this regulator provides the delivery pressure to customer.
53. Relief Set Point: Enter the relief valve set point.
54. Regulator Model: Enter the regulator model number (e.g., Fisher 99).
55. Regulator Type: Identify the regulator type; check one.
56. Regulator Body Size: Enter the regulator body size.
57. Orifice Size/Trim Size: Enter the regulator orifice/trim size.
58. Spring Color/Range: Enter the regulator spring range and color.
59. Regulator Set Point: Enter the regulator set point.
60. Relief Model: Enter the relief valve model number (e.g., Fisher 63 EG).
61. Relief Size: Enter the relief valve body size.

UNCONTROLLED IF PRINTED

- 62. Delivery Pressure ? : Check if this regulator provides the delivery pressure to customer.
- 63. Relief Set Point: Enter the relief valve set point.
- 64. Supervisor Review Initials: Enter the initials of the supervisor completing the review of completed form.
- 65. Date: Enter date form was reviewed.

A-3. Removal Information (Page 2 of 2)

A-3.1 General Customer Information

- 66. Date: Enter the date the metering equipment was removed.
- 67. Meter #: Enter 8-digit manufacturer serial number shown on the nameplate or badge of meter. Enter leading "zeros" if the manufacturer serial number is less than 8 characters. For legacy CILCO meters, enter the AIC meter number, for reference, in the Remarks section.
- 68. CRTS#: Enter the Construction Request Tracking System number provided for gas metering projects from customer related work requests.
- 69. Customer: Enter the customer name.
- 70. Address: Enter the address where gas metering equipment is being removed.
- 71. OAS#: Enter the OAS order number, if applicable.
- 72. City: Enter the city (town) where the customer is located.
- 73. Employee Name/ID: Enter the name of the employee completing the customer order or performing the work.
- 74. Laptop/Asset#: Enter company laptop/asset number for the device used to complete any programming or downloading data.
- 75. Employee Phone #: Enter a phone number where the employee completing the GMDS can be contacted for any necessary follow-up.

A-3.2 Removal Information

- 76. Meter Size: Enter the actual gas meter size from the meter badge (e.g., 16M175 TC, AL-800).
- 77. Meter Code: Enter the 5-digit gas meter code (e.g., meter code for 16M175 TC meter is 04361). A listing of gas meter codes is available from the Gas Metering Supervisor.
- 78. Customer Classification: Mark the appropriate rate class for customer.

A-3.3 Pressure Factor Information (No Corrector/Corrector Removed)

- 79. Meter Pressure: Enter the approved elevated metering pressure established for the installation. Standard elevated metering pressures for new installations are 2 psig, 5 psig, 10 psig, and 15 psig. The pressure should be identified and/or verified with a calibrating gauge.
- 80. Meter Reading: Enter the meter index reading - enter as "right justified" with leading zeros. If no meter index, note such in Remarks section or enter "N/A" in the reading field.

81. Number of Dials: Identify the number of dials on meter index; the number of dials does not include the test hand(s). Check the number of dials, typically 4, 5, or 6.

A-3.4 Auxiliary Equipment Information

82. Manufacturer: Enter the manufacturer of auxiliary equipment being removed; (e.g., Mercury, American).
83. Serial Number: Enter the manufacturer's serial number of the auxiliary equipment.
84. Model Type: Enter the auxiliary equipment model type (e.g., Mini-AT100).
85. Meter Pressure: Enter the approved elevated metering pressure established for the installation. Pressure should be identified and/or verified with a calibrating gauge. The pressure should match the pressure displayed on corrector within ± 0.5 psig.
86. Programmed Unit of Measure: Enter the unit of gas measurement as programmed into correcting device. It is generally programmed to display in hundreds of cubic feet (CCF) or thousands of cubic feet (MCF). Therefore, check the appropriate value which is "CCF (100)" or "MCF (1000)".
87. Corrected Reading: Enter the corrected meter reading from the LCD display of the electronic correcting device. Enter reading as "right justified" with leading zeros and a maximum of 6 digits.
88. Uncorrected Reading: Enter the uncorrected meter reading from LCD display of the electronic correcting device. Enter reading as "right justified" with leading zeros and a maximum of 6 digits.
89. Instrument Base Mechanical Index: Enter the uncorrected mechanical reading found at the base of correcting device.
90. Rotary Meter Index Reading: Enter rotary meter index reading for the rotary meter removed.

A-3.5 Remarks and Review

91. Remarks: Enter additional information that will assist with completing the order. **Also, attach all of the required pictures to the electronic GMDS for the work performed.**
92. Illinois Distribution List: Identifies the routing of copies for a completed Gas Meter Data Sheet.
93. Missouri Distribution List: Identifies the routing of copies for a completed Gas Meter Data Sheet.
94. Supervisor Review Initials: Enter the initials of the supervisor completing the review of the completed form.
95. Date: Enter the date the form was reviewed.

Appendix B - Gas Meter Data Sheet

[\(View/download PDF version\)](#)

UNCONTROLLED IF PRINTED

		GAS METER DATA SHEET	
DATE 1	METER # 2	CRTS# 3	
RATE ZONE I	RATE ZONE II	RATE ZONE III	
4 <input type="checkbox"/> AMEREN CIPS	<input type="checkbox"/> AMEREN CILCO	<input type="checkbox"/> AMEREN IP	<input type="checkbox"/> AMEREN MISSOURI
ACTION/REASON			
5 <input type="checkbox"/> INSTALLATION <input type="checkbox"/> EXCHANGE <input type="checkbox"/> REMOVAL <input type="checkbox"/> REPLACED ELECTRONIC CORRECTOR <input type="checkbox"/> OTHER (EXPLAIN IN REMARKS)			
CUSTOMER: 6	OAS# 8		
ADDRESS: 7	CITY: 9		
EMPLOYEE NAME / ID: 10	LAPTOP / ASSET#: 11	EMPLOYEE PHONE#: 12	
INSTALLATION INFORMATION			
METER SIZE: 13	METER CODE: 14	<input type="checkbox"/> RESIDENTIAL <input checked="" type="checkbox"/> NONRESIDENTIAL	
BY PASS: 10 <input type="checkbox"/> YES <input type="checkbox"/> NO	METER DRIVE: <input type="checkbox"/> 1 FT <input type="checkbox"/> 2 FT <input type="checkbox"/> 5 FT <input type="checkbox"/> 10 FT <input type="checkbox"/> 100 FT <input type="checkbox"/> 1000 FT	18 <input type="checkbox"/> TC	<input type="checkbox"/> Non-TC
19 GAS TRANSPORT CUSTOMER: <input type="checkbox"/> YES <input type="checkbox"/> NO	20 TEST PLUGS: <input type="checkbox"/> YES <input type="checkbox"/> NO	21 METER LEFT: <input type="checkbox"/> ON <input type="checkbox"/> OFF <input type="checkbox"/> LOCKED	
PRESSURE FACTOR INFORMATION (NO CORRECTOR/CORRECTOR REMOVED)			
METER PRESSURE: <input type="checkbox"/> 7" <input type="checkbox"/> 2" <input type="checkbox"/> 5" <input type="checkbox"/> 10" <input type="checkbox"/> 15" <input type="checkbox"/> OTHER 22	METER READING: 23		
METER PRESSURE TAG: 24 <input type="checkbox"/> YES <input type="checkbox"/> NO	NUMBER OF DIAL: 25 <input type="checkbox"/> 4 <input type="checkbox"/> 5 <input type="checkbox"/> 6		
AUXILIARY EQUIPMENT INFORMATION			
MANUFACTURER: 26	CORRECTED READING: 32		
SERIAL NUMBER: 27	CORRECTED READING MULTIPLIER: 33 <input type="checkbox"/> 1 <input type="checkbox"/> 10		
MODEL TYPE: 28	UNCORRECTED READING: 34		
METER PRESSURE: 29	INSTRUMENT BASE MECHANICAL READING: 35		
PRESSURE TRANSDUCER RANGE: 30	ROTARY METER INDEX READING: 36		
31 PROGRAMMED UNIT OF MEASURE (CSS CORRECTED COUNTER VALUE): <input type="checkbox"/> CCF (100) <input type="checkbox"/> MCF (1000)			
TIME OF DAY: 37 <input type="checkbox"/> AM <input type="checkbox"/> PM	LAN ID: 38		
SITE ID #1: 39	DEVICE BAUD RATE: <input type="checkbox"/> 2400 <input type="checkbox"/> 9600		
SITE ID #2: 40	DEVICE PHONE #: 42		
METER SET REGULATOR/RELIEF INFORMATION			
43 REGULATOR LOCATION(s): <input type="checkbox"/> UPSTREAM OF METER <input type="checkbox"/> DOWNSTREAM OF METER <input type="checkbox"/> DOWN & UPSTREAM OF METER <input type="checkbox"/> MONITOR			
REGULATOR MODEL: 44	RELIEF MODEL: 50	REGULATOR MODEL: 54	RELIEF MODEL: 60
45 REGULATOR TYPE: <input type="checkbox"/> 1 ST Cut <input type="checkbox"/> 2 ND Cut <input type="checkbox"/> MONITOR <input type="checkbox"/> WORKER		REGULATOR TYPE: <input type="checkbox"/> 1 ST Cut <input type="checkbox"/> 2 ND Cut <input type="checkbox"/> MONITOR <input type="checkbox"/> WORKER	
REGULATOR BODY SIZE: 46	RELIEF SIZE: 51	REGULATOR BODY SIZE: 56	RELIEF SIZE: 61
ORIFICE SIZE/TRIM SIZE: 47	52 DELIVERY PRESS? <input type="checkbox"/>	ORIFICE SIZE/TRIM SIZE: 57	DELIVERY PRESS? <input type="checkbox"/> 62
SPRING COLOR/RANGE: 48	SPRING COLOR/RANGE: 58		
REGULATOR SET POINT: 49	RELIEF SET POINT: 53	REGULATOR SET POINT: 59	RELIEF SET POINT: 63
STK # 37-41-384 FORM # 5877	Revision 7/11/18	Supervisor Review Initials: 64	Date: 65
Page 1 of 2			

Appendix B - Gas Meter Data Sheet (Page 2)



GAS METER DATA SHEET

DATE: <input type="text" value="66"/>	METER #: <input type="text" value="67"/> <input type="text"/> <input type="text"/> <input type="text"/> <input type="text"/> <input type="text"/>	CRTS#: <input type="text" value="68"/>
CUSTOMER: <input type="text" value="69"/>	OAS#: <input type="text" value="71"/>	
ADDRESS: <input type="text" value="70"/>	CITY: <input type="text" value="72"/>	
EMPLOYEE NAME / ID: <input type="text" value="73"/>	LAPTOP / ASSET#: <input type="text" value="74"/>	EMPLOYEE PHONE#: <input type="text" value="75"/>
REMOVAL INFORMATION		
METER SIZE: <input type="text" value="76"/> <input type="text"/> <input type="text"/> <input type="text"/> <input type="text"/> <input type="text"/>	METER CODE: <input type="text" value="77"/> <input type="text"/> <input type="text"/> <input type="text"/> <input type="text"/>	<input type="checkbox"/> RESIDENTIAL <input checked="" type="checkbox"/> NONRESIDENTIAL <input type="text" value="78"/>
PRESSURE FACTOR INFORMATION (NO CORRECTOR/CORRECTOR REMOVED)		
METER PRESSURE: <input type="checkbox"/> 7" <input type="checkbox"/> 2" <input type="checkbox"/> 5" <input type="checkbox"/> 10" <input type="checkbox"/> 15" <input type="checkbox"/> OTHER <input type="text" value="79"/>		
METER READING: <input type="text" value="80"/> <input type="text"/> <input type="text"/> <input type="text"/> <input type="text"/> <input type="text"/>		
NUMBER OF DIALS: <input type="checkbox"/> 4 <input type="checkbox"/> 5 <input type="checkbox"/> 6 <input checked="" type="checkbox"/> 81		
AUXILIARY EQUIPMENT INFORMATION		
MANUFACTURER: <input type="text" value="82"/>	CORRECTED READING: <input type="text" value="87"/> <input type="text"/> <input type="text"/> <input type="text"/> <input type="text"/> <input type="text"/>	
SERIAL NUMBER: <input type="text" value="83"/>	UNCORRECTED READING: <input type="text" value="88"/> <input type="text"/> <input type="text"/> <input type="text"/> <input type="text"/> <input type="text"/>	
MODEL TYPE: <input type="text" value="84"/>	INSTRUMENT BASE MECHANICAL INDEX <input type="text" value="89"/> <input type="text"/> <input type="text"/> <input type="text"/> <input type="text"/> <input type="text"/>	
METER PRESSURE: <input type="text" value="85"/>	ROTARY METER INDEX READING <input type="text" value="90"/> <input type="text"/> <input type="text"/> <input type="text"/> <input type="text"/> <input type="text"/>	
<input checked="" type="checkbox"/> 86 PROGRAMMED UNIT OF MEASURE (CSS CORRECTED COUNTER VALUE): <input type="checkbox"/> CCF (100) <input type="checkbox"/> MCF (1000)		

Remarks:

Illinois Distribution List (copy both sides) (Reference O&M for Routing Instructions): <input type="text" value="92"/> <ol style="list-style-type: none"> Local Office @IL_GMDS @PeoriaGasTransport - IL Customer Accounts (IL CAD) @IL_GT_Clerical - (for 11M & Larger) STK # 37-41-384 FORM # 5877	Missouri Distribution List (copy both sides): <input type="text" value="93"/> <ol style="list-style-type: none"> Local Office Gas Metering Supervisor MO Customer Accounts (MO CAD): @DLMV90GasMO for Gas Transport Accounts Revision 7/11/18 Page 2 of 2
	Supervisor Review Initials: <input type="text" value="94"/> Date: <input type="text" value="95"/>

UNCONTROLLED IF PRINTED

METERING

October 1, 2021

METR 3.1 Meter Sizing

1.0 Purpose

This standard prescribes the sizing criteria and capacities for gas meters approved for new or existing installations by Ameren Illinois (AIC).

2.0 Scope

This document addresses the following:

[3.0 Target Audience](#)[4.0 Sizing Criteria](#)[5.0 Approved Meters for New Installations](#)[6.0 Existing Diaphragm Meter Installations](#)[7.0 Existing Rotary Meter Installations](#)

Appendices

[Appendix A - Approved Meters for New Locations](#)[Appendix B - Capacities for Existing Diaphragm Meter Installations](#)[Appendix B-1 - Capacities for American and Rockwell Meters](#)[Appendix B-2 - Capacities for Sprague Meters](#)[Appendix B-3 - Capacities for American Meters at Higher Pressure](#)[Appendix B-4 - NOTES common to all Appendix B Tables](#)[Appendix C - Capacities for Existing Rotary Meter Installations](#)**3.0 Target Audience**

- Gas Engineering
- Gas Supervisors
- Gas Field Personnel
- Gas Technical Services (GTS) Supervisor
- Gas Meter Supervisor
- Gas Tech Engineering (GTE)

4.0 Sizing Criteria

4.1 Contact Gas Tech Engineering for selection and approval of meters larger than:

- 4.1.1 Roots 7M175,
- 4.1.2 Delivery pressure greater than 10 psig, OR
- 4.1.3 A connected load greater than 10,000 scfh.

4.2 Meter Sizing Criteria

4.2.1 Size meters for the maximum load according to the following criteria - meters operating at:

1. Inches delivery (normally considered to be 7 inches w.c.) shall be sized for a maximum differential of 1 inch w.c.

UNCONTROLLED IF PRINTED

2. Pounds delivery (e.g., 2, 5, 10, 15 psig) shall be sized for a maximum differential of at least 2 inches w.c.
3. Distribution line pressure shall be sized for maximum load at minimum distribution pressure.

5.0 Approved Meters for New Installations

5.1 See [Appendix A](#) for approved meters applicable to new gas service installations.

6.0 Existing Diaphragm Meter Installations

6.1 See [Appendix B](#) that lists capacities for existing diaphragm meter installations as follows:

- [Appendix B-1](#) - Capacities for American and Rockwell Meters
- [Appendix B-2](#) - Capacities for Sprague Meters
- [Appendix B-3](#) - Capacities for American Meters at Higher Pressure
- [Appendix B-4](#) - NOTES common to all Appendix B Tables

7.0 Existing Rotary Meter Installations

7.1 See [Appendix C](#) that lists capacities for existing rotary meter installations.

End of Instructions.

Operator Qualification (OQ) Required?

NONE.

Appendices

[Appendix A - Approved Meters for New Locations](#)

[Appendix B - Capacities for Existing Diaphragm Meter Installations](#)

[Appendix B-1 - Capacities for American and Rockwell Meters](#)

[Appendix B-2 - Capacities for Sprague Meters](#)

[Appendix B-3 - Capacities for American Meters at Higher Pressure](#)

[Appendix B-4 - NOTES common to all Appendix B Tables](#)

[Appendix C - Capacities for Existing Rotary Meter Installations](#)

Attachments

NONE.

Compliance Requirements

Illinois Commerce Commission (ICC) Title 83: Public Utilities, Part 501, Standards of Service for Gas Utilities and Alternative Gas Suppliers, specifically Subpart B: Natural Gas Measurement Requirements, available online [here](#).

Reference Documents

NONE.

Document Rescission

METR 3.1 Metering: Meter Sizing, October 1, 2020.

UNCONTROLLED IF PRINTED

Revision Notes

Location of Changes	Summary of Changes
Appendix A – A-1	AC630: No Fixed Factor billing above 15 psig and corrector cannot be attached to the meter.
Appendix B – B-1	AL425 or AC630: No Fixed Factor billing above 15 psig and corrector cannot be attached to the meter.
Appendix B – B-2	Sprague #3, #4, #5: No Fixed Factor billing above 15 psig and corrector cannot be attached to the meter.

Appendix A - Approved Meters for New Installations

A-1. Capacities for approved new meter installations:

Meter Capacities (CFH) (Notes 1 & 2)							
Meter Type	Metering Pressure						
	7" w.c.	2 psig	5 psig	10 psig	15 psig	20 psig	25 psig
American AC 250 (3)	375	660	750				
American AL 425 10 lb.	640	970	1,100				
American AC 630	910	1,390	1,515	1,710	1,890		
Roots 15C175 (4)	1,500	1,670	2,000	2,500	3,000	3,500	4,000
Roots 3 / 3.5M175 (4)	3,000	3,340	4,000	5,000	6,000	7,000	8,000
Roots 5 / 5.5M175 (4)	5,000	5,570	6,600	8,300	10,000	11,700	13,400
Roots 7M175	7,000	7,790	9,200	11,600	14,000	16,300	18,700

(Yellow Shaded area indicates sizing by Gas Tech Engineering.) **Notes:** (1) Capacities at 7" w.c. metering pressure are for 1" w.c. pressure drop across the meter. (2) Capacities are for 0.60 specific gravity gas. (3) Alternate meter option includes the Sensus R275 AccuWave. (4) Alternate meter options include the American 15C, 3.5M and 5.5M or Romet of comparable sizes.

Appendix B - Capacities for Existing Diaphragm Meter Installations

B-1. Capacities for American and Rockwell meters:

Meter Capacities (CFH) (Notes 1, 2 & 3 - See Section B-4 .)							
Meter Type	Metering Pressure						
	7" w.c.	2 psig	5 psig	10 psig	15 psig	20 psig	25 psig
American 175 AL	260	500	565				
American AL 5B-225	324						
American AC 250	375	660	750				
American AL 250	375	660	750				
American AL 425 10 lb.	640	970	1,100	1,350			
American AL 425	640	970	1,100	1,350	1,500		
American AC 630	910	1,390	1,515	1,710	1,890		
American AL 800	1,200	1,840	2,100	2,600	2,800	3,200	3,500
American AL1000	1,500	2,380	2,700	3,400	3,700	4,100	4,600

UNCONTROLLED IF PRINTED

American Metric 80B	1,700	2,640	3,100	3,700	4,300	4,800	5,300
American AL1400	2,100	3,250	3,700	4,600	5,000	5,600	6,200
American AL 2300	3,450	5,440	6,200	7,700	8,400	9,400	10,400
American Metric 250B	4,250	6,550	7,500	8,900	10,000	12,000	13,000
American 500B	7,000	10,920	12,500	15,000	17,000	19,000	21,000
American AL 5000	7,500	11,920	13,500	17,000	18,500	20,600	23,000
Rockwell Emco 0	277						
Rockwell Emco #1	400						
Rockwell R 175	240	500	565				
Rockwell 250	375	600	750				
Rockwell R 275	375	600	750				
Rockwell Emco 2	615						
Rockwell 750	1,100	1,790	2,070	2,480	2,840	3,130	
Rockwell 3000	2,010	3,250	3,880	4,660	5,400	5,820	6,700
Rockwell 5000	3,710	5,500	6,450	7,750	9,000	10,100	11,100
Rockwell 10000	7,000	11,000	12,900	15,550	18,000	20,200	22,300

B-2. Capacities for Sprague meters:

Meter Capacities (CFH) (Notes 1, 2 & 3 - See Section B-4)							
Meter Type	Metering Pressure						
	7" w.c.	2 psig	5 psig	10 psig	15 psig	20 psig	25 psig
Sprague 175	240	500	565				
Sprague 1A	241						
Sprague 175 AL	240	500	565				
Sprague 240	350	585	660				
Sprague 250	375	660	750				
Sprague #2	435						
Sprague #3	575	930	1,050	1,250	1,440		
Sprague #4	918	1,430	1,625	1,930	2,220		
Sprague #5	1,428	2,210	2,500	2,970	3,420		

B-3. Capacities for American meters at higher pressure:

Meter Capacities (CFH) (Notes 1, 2 & 3 - See Section B-4)						
Meter Type	Metering Pressure					
	30 psig	35 psig	40 psig	45 psig	50 psig	55 psig
American AL 800	3,700	4,050	4,400	4,750	5,100	5,380
American 80B	5,800	6,275	6,750	7,225	7,700	8,104
American AL 1400	6,500	7,125	7,750	8,375	9,000	9,500
American AL 2300	11,400	12,300	13,200	14,100	15,000	15,800
American 250B.	14,000	15,000	16,000	17,000	18,000	19,200
American 500B	23,000	25,000	27,000	29,000	31,000	32,600
American AL 5000	25,000	27,000	29,000	31,000	33,000	34,800

UNCONTROLLED IF PRINTED

B-4. NOTES common to all Appendix B tables:

1. Capacities at 7" w.c. metering pressure are for 1" w.c. pressure drop across the meter.
2. Capacities above 7" w.c. metering pressure are for 2" w.c. pressure drop across the meter.
3. Capacities are for 0.60 specific gravity gas.

Appendix C - Capacities for Existing Rotary Meter Installations

C-1. Capacities for existing rotary meter installations:

Meter Capacities (CFH) (Notes 1 & 2)										
Meter Type	Metering Pressure									
	7" w.c.	2 psig	5 psig	10 psig	15 psig	20 psig	25 psig	40 psig	50 psig	125 psig
Roots 8C175 Line Mount	800	890	1,050	1,330	1,600	1,870	2,140	2,960	3,500	7,570
Roots 11C175 Line Mount	1,100	1,230	1,450	1,820	2,200	2,570	2,940	4,060	4,810	10,400
Roots 15C175 Line Mount	1,500	1,670	2,000	2,500	3,000	3,500	4,000	5,500	6,600	14,200
Roots 2M175 Line Mount	2,000	2,230	2,630	3,310	3,890	4,670	5,350	7,350	8,740	18,900
Roots 3M175 Line Mount	3,000	3,340	4,000	5,000	6,000	7,000	8,000	11,100	13,100	28,400
Roots 5M175 Line Mount	5,000	5,570	6,600	8,300	10,000	11,700	13,400	18,500	21,900	47,300
Roots 7M175 Line Mount	7,000	7,790	9,200	11,600	14,000	16,300	18,700	25,900	30,600	66,200
Roots 11M175 Line Mount	11,000	12,240	14,500	18,200	22,000	25,700	29,400	40,600	48,100	104,100
Roots 16M175 Line Mount	16,000	17,810	21,100	26,500	31,900	37,400	42,800	59,100	70,000	151,400
Roots 23M125 Foot Mount	23,000	25,600	30,300	38,100	45,900	53,700	61,500	84,900	100,600	217,700
Roots 38M125 Foot Mount	38,000	42,290	50,000	62,900	75,800	88,700	101,700	140,300	166,100	359,600
Roots 56M125 Foot Mount	56,000	62,330	73,800	92,700	111,800	130,800	149,800	206,800	244,800	434,900
Roots 102M125 Foot Mount	102,000	113,530	134,300	168,900	203,600	238,200	272,900	376,700	445,900	965,300

Notes:

1. Capacities at 7" w.c. metering pressure are for 1" w.c. pressure drop across the meter.
2. Capacities are for 0.60 specific gravity gas.

End of Appendices

METERING

April 1, 2023

METR 3.2 Regulator Sizing

1.0 Purpose

This standard prescribes the capacities for gas regulators approved for new installations by Ameren Illinois (AIC) with various delivery pressures ranging from 7 inches w.c. to 10 psig.

2.0 Scope

This document addresses the following:

[3.0 Target Audience](#)[4.0 General](#)[5.0 Regulator Sizing @ 7" w.c. Delivery Pressure](#)[6.0 Regulator Sizing @ 2 psig Delivery Pressure](#)[7.0 Regulator Sizing @ 5 psig Delivery Pressure](#)[8.0 Regulator Sizing @ 10 psig Delivery Pressure](#)[9.0 Alternative Regulator Sizing @ Various Delivery Pressures](#)

Appendices

[Appendix A - New Regulators for Installation @ 7" w.c. Delivery Pressure](#)[Appendix B - New Regulators for Installation @ 2 psig Delivery Pressure](#)[Appendix C - New Regulators for Installation @ 5 psig Delivery Pressure](#)[Appendix D - New Regulators for Installation @ 10 psig Delivery Pressure](#)[Appendix E - Alternative Regulator Sizing @ Various Delivery Pressures](#)**3.0 Target Audience**

- Gas Engineering
- Gas Supervisors
- Gas Field Personnel
- Gas Technical Services (GTS) Supervisor
- Gas Meter Supervisor
- Gas Tech Engineering (GTE)

4.0 General

- 4.1 The standard covered herein is based on proven and acceptable regulators with tables constructed to show delivery capacities at the operating pressure parameters (i.e., given inlet pressure and established delivery pressure).
- 4.2 Contact Gas Tech Engineering (GTE) for selection and approval of regulators with connected loads greater than 10,000 CFH, delivery pressure greater than 10 psig, and/or inlet pressures greater than 60 psig.
- 4.3 Contact engineering for slam-shut regulator selection when a clearance issue is identified between an ignition source or building vent and the existing gas service regulator relief vent that can't be relocated.

5.0 Regulator Sizing @ 7" w.c. Delivery Pressure

UNCONTROLLED IF PRINTED

- 5.1 See [Appendix A](#) for approved regulators and their respective capacities for new installations to deliver 7" w.c. pressure to the customer.

6.0 Regulator Sizing @ 2 psig Delivery Pressure

- 6.1 See [Appendix B](#) for approved regulators and their respective capacities for new installations to deliver 2 psig pressure to the customer.

7.0 Regulator Sizing @ 5 psig Delivery Pressure

- 7.1 See [Appendix C](#) for approved regulators and their respective capacities for new installations to deliver 5 psig pressure to the customer.

8.0 Regulator Sizing @ 10 psig Delivery Pressure

- 8.1 See [Appendix D](#) for approved regulators and their respective capacities for new installations to deliver 10 psig pressure to the customer.

9.0 Alternative Regulator Sizing @ Various Delivery Pressures

- 9.1 See [Appendix E](#) for possible alternative regulators and their respective capacities for new installations to deliver various pressure to the customer. (i.e., 7" w.c., 2 psig, 5 psig, or 10 psig).
- 9.2 See [Subsection 4.2](#) on contacting Gas Tech Engineering for selection and approval.

End of Instructions.

Operator Qualification (OQ) Required?

NO.

Appendices

[Appendix A - New Regulators for Installation @ 7" w.c. Delivery Pressure](#)

[Appendix B - New Regulators for Installation @ 2 psig Delivery Pressure](#)

[Appendix C - New Regulators for Installation @ 5 psig Delivery Pressure](#)

[Appendix D - New Regulators for Installation @ 10 psig Delivery Pressure](#)

[Appendix E - Alternative Regulator Sizing @ Various Delivery Pressures](#)

Attachments

NONE.

Compliance Requirements

49 CFR §192.197 Control of the pressure of gas delivered from high-pressure distribution systems.

Illinois Commerce Commission (ICC) Title 83: Public Utilities, Part 501, Standards of Service for Gas Utilities and Alternative Gas Suppliers, Subpart D: Gas Service Standards, specifically Sections 501.500 Pressure Regulation and 501.540 Good Engineering Practice, available online [here](#).

Reference Documents

NONE.

Document Rescission

UNCONTROLLED IF PRINTED

METR 3.2 Regulator Sizing – October 1, 2022

Revision Notes

Location of Changes	Summary of Changes
Subsection 4.2	Gas Tech Engineering (GTE) replaces Gas Tech Services Engineering.
Appendix C – 5 PSIG Delivery Pressure	Contact GTE when 2" Fisher 299H with either 3/8" orifice or 1/2" orifice is proposed when Minimum Distribution Pressure is 80 PSIG or greater. Removed Note (5) that had been added in October 1, 2022
Appendix D – 10 PSIG Delivery Pressure	Contact GTE when 2" Fisher 299H with 3/8" orifice is proposed when Minimum Distribution Pressure is 80 PSIG or greater. Contact GTE when 2" Fisher 299H with 1/2" orifice is proposed when Minimum Distribution Pressure is 60 PSIG or greater. Removed Note (6) that had been added in October 1, 2022
Appendix E – Alternative Regulator Sizing = E-1 – 7" w.c. Delivery Pressure	Updated the Relief Valve for 2" Itron B34R with 1/4" orifice and 3/8" orifice. Added Notes: (8) for 2" Itron B34R with 3/8" orifice – Do Not exceed 125 psig MAOP Inlet Pressure. (9) for 2" Itron B34R with 1/2" orifice – Do Not exceed 75 psig MAOP Inlet Pressure. (10) for 2" Itron B34R with 5/8" orifice – Do Not exceed 60 psig MAOP Inlet Pressure.
Appendix E – E-2 – 2 psig Delivery Pressure	Contact GTE replaced capacity value for 2" Itron B34-2 with 3/8" orifice. Note (6) – Added Itron
Appendix E – E-3 – 5 psig Delivery Pressure	Note (3) – Itron replaces Actaris
Appendix E – E-4 – 10 psig Delivery Pressure	Note (3) – Itron replaces Actaris

Appendix A - Regulators for New Installation @ 7" w.c. Delivery Pressure

Regulator Capacities (SCFH) (1)							
Regulator Type	Stock No.	Minimum Distribution Pressure					
		5 psig	10 psig	15 psig	20 psig	30 psig	40 psig

UNCONTROLLED IF PRINTED

3/4" X 1" Itron B42R 1/8" x 3/16" Ori- fice (2)	62 06 172	280	390	470	550	700	870
3/4" X 1" American 1813C 1/8" x 3/16" Ori- fice (3)	62 06 172	250	350	425	500	600	750
3/4" X 1" Itron B42R 3/16" Ori- fice (2)	62 06 187	400	625	850	1,100	1,400	1,750
3/4" X 1" American 1813C 3/16" Ori- fice, (3)	62 06 187	450	700	900	1,100	1,400	1,700
3/4" X 1" Itron B42R 1/4" Ori- fice (2) (8)	62 06 484 Engineering only	500	850	1,200	1,450	2,000	2,200
3/4" X 1" American 1813C 1/4" Ori- fice (3) (4)	62 06 484 Engineering only	650	1,000	1,400	1,700	2,300	2,500
1" x 1" Itron B42R 1/8" x 3/16" Ori- fice (2)	62 06 493	280	390	470	550	700	870
1" X 1" American 1813C 1/8" x 3/16" Ori- fice (3)	62 06 493	250	350	425	500	600	750
1" x 1" Itron B42R 3/16" Ori- fice (2)	62 06 475	400	625	850	1,100	1,400	1,750
1" X 1" American 1813C 3/16" Ori- fice (3)	62 06 475	450	700	900	1,100	1,400	1,700
1" X 1" Itron B42R 1/4" Orifice (2) (8)	62 06 494 Engineering only	500	850	1,200	1,450	2,000	2,200
1" X 1" American 1813C 1/4" Ori- fice (3) (4)	62 06 494 Engineering only	650	1,000	1,400	1,700	2,300	2,500
1" x 1" Pietro Fiorentini FE25 (Slam-Shut)	62 06 496	910	910	910	910	910	910
1" x 1" BelGas P100SX (Slam-Shut)	62 06 495	1,132	1,358	1,403	1,539	1,539	1,539
1-1/4" Fisher CS400IR 3/16" Ori- fice (5)	62 06 175	500	750	1000	1,100	1,500	1,900
1-1/4" Fisher CS400IR 1/4" Ori- fice (5) (6)	Non-Stock Engineering only	800	1,200	1,700	1,900	2,700	2,800
2" Fisher CS806-IQ 3/8" Ori- fice (7)	62 06 180	1,670	2,750	3,670	4,630	6,330	7,930
2" Fisher CS806-IQ 1/2" Ori- fice (7)	62 06 151	2,520	4,190	6,350	7,910	10,350	12,000

Regulator Capacities (SCFH)					
Regulator Type	Stock No.	Minimum Distribution Pressure			
		60 psig	80 psig	100 psig	125 psig
3/4" X 1" Itron B42R 1/8" x 3/16" Ori- fice (2)	62 06 172	1,190	1,590	1,870	2280
3/4" X 1" American 1813C 1/8" x 3/16" Ori- fice (3)	62 06 172	1,000	1300	1,600	2000
3/4" X 1" Itron B42R 3/16" Ori- fice, (2)	62 06 187	2,300	Contact GTE	Contact GTE	Contact GTE

UNCONTROLLED IF PRINTED

3/4" X 1" American 1813C 3/16" Orifice (3)	62 06 187	2,400	Contact GTE	Contact GTE	Contact GTE
3/4" X 1" Itron B42R 1/4" Orifice (8)	62 06 484 Engineering only	2,500			
3/4" X 1" American 1813C 1/4" Orifice (3) (4)	62 06 484 Engineering only	2,500			
1" x 1" Itron B42R 1/8" x 3/16" Orifice (2)	62 06 493	1,190	1,590	1,870	2280
1" X 1" American 1813C 1/8" x 3/16" Orifice (3)	62 06 493	1,000	1,300	1,600	2000
1" x 1" Itron B42R 3/16" Orifice (2)	62 06 475	2,300	Contact GTE	Contact GTE	Contact GTE
1" X 1" American 1813C 3/16" Orifice (3)	62 06 475	2,400	Contact GTE	Contact GTE	Contact GTE
1" X 1" Itron B42R 1/4" Orifice (2) (8)	62 06 494 Engineering only	2,500			
1" X 1" American 1813C 1/4" Orifice (3) (4)	62 06 494 Engineering only	2,500			
1" x 1" Pietro Fiorentini FE25 (Slam-Shut)	62 06 496	910	910	910	910
1" x 1" BelGas P100SX (Slam-Shut)	62 06 495	1,539	1,539	1,539	1,539
1-1/4" Fisher CS400IR 3/16" Orifice (5)	62 06 175	2,600	Contact GTE		
1-1/4" Fisher CS400IR 1/4" Orifice (5) (6)	Non-Stock Engineering only				
2" Fisher CS806-IQ 3/8" Orifice (7)	62 06 180	10,800	Contact GTE	Contact GTE	Contact GTE
2" Fisher CS806-IQ 1/2" Orifice (7)	62 06 151	12,500	Contact GTE	Contact GTE	Contact GTE

(Shaded area with no capacity indicates max operating inlet pressure is exceeded for a given orifice.)

Notes:

- (1) Capacities are for 0.60 specific gravity gas with 1% absolute droop. Relief capacities are calculated using 60 psig inlet and 2 psig customer MEP.
- (2) Itron B42R use Main Spring R17444-B42R (Brown), 6" to 8" w.c. range, set 7" w.c.
- (3) American 1813C use Main Spring 70017P044 (Yellow), 5.5" to 8.5" w.c. range, set 7" w.c. with no vent pipe.
- (4) American 1813C- Engineering Only - **Do not exceed 48 psig MAOP inlet pressure** (limited by internal relief capacity). For MAOP greater than 48 psig, use 1" Fisher 289L Relief Valve with 13A7916X012 Spring, range 12" to 40" w.c., set 14" w.c., maximum buildup @ 2 psig, and capacity 8 MCF. (Stock Code 39 22 037)
- (5) Fisher CS400IR use Main Spring GE30188X012 (Gold), 6 to 8" w.c., set 7" w.c.
- (6) Fisher CS400IR - Engineering Only - Order 1/4" orifice and install in 62 06 175 if extra capacity is necessary. Use Main spring GE30188X012 (Gold), 6 to 8" w.c., set 7" w.c. **Do not exceed 54 psig MAOP inlet pressure** (limited by internal relief capacity). For MAOP greater than 54 psig, use 1" Fisher 289L Relief Valve with

UNCONTROLLED IF PRINTED

- 13A7916X012 Spring, range 12" to 40" w.c., set 14" w.c., maximum buildup @ 2 psig, and capacity 8 MCF. (Stock Code 39 22 037)
- (7) Fisher CS806-IQ use Main Spring GE30338X012 (Black), 5.5" to 8.5" w.c., set 7" w.c. Internal Relief set point 18 - 25" w.c., maximum buildup @ 2 psig. Secondary seat operation = 25" w.c. at full inlet.
- (8) Itron B42R - Engineering Only - Order 1/4" orifice and install in 62 06 187 if extra capacity is necessary. **Do not exceed 28 psig MAOP Inlet pressure** (limited by internal relief capacity). For MAOP over 28 psig, use 1" Fisher 289L Relief Valve with 13A7916X012 Spring, range 12" to 40" w.c., set 14" w.c., maximum buildup @ 2 psig, and capacity 8 MCF. (Stock Code 39 22 037)
- (9) Overpressure protection (slam-shut) reset shall follow manufacturer's recommendations.
- (10) Pietro Fiorentini FE25 use Main Spring (Yellow), 6" to 8" w.c. range, set 7" w.c., relief set at 14" w.c., slam shut set at 28" w.c
- (11) Belgas P100SX use Main Spring (007), 6" to 8" w.c. range, set 7" w.c., relief set at 14" w.c., slam shut set at 28" w.c

Appendix B - Regulators for New Installation @ 2 psig Delivery Pressure

Regulator Capacities (SCFH) (1)								
Regulator Type	Stock No.	Minimum Distribution Pressure						
		5 psig	10 psig	15 psig	20 psig	30 psig	40 psig	60 psig
3/4" X 1" Itron B42R 3/16" Orifice, 1-2 psig (2)	62 06 173	230	370	500	600	900	1,100	1,600
3/4" X 1" American 1813C 3/16" Orifice (3)	62 06 173	350	600	800	1,000	1,300	1,700	2,500
3/4" X 1" Itron B42R 1/4" Orifice, 1-2 psig (2)(7)	62 06 482	290	490	650	840	1,230	1,600	2,240
3/4" X 1" American 1813C 1/4" Orifice (3)	62 06 482	450	750	1,000	1,200	1,700	2,200	2,500
1" x 1" Itron B42R 3/16" Orifice, 1-2 psig (2)	62 06 486	230	370	500	600	900	1,100	1,600
1" X 1" American 1813C 3/16" Orifice (3)	62 06 486	350	600	800	1,000	1,300	1,700	2,500
1-1/4" American 1813C 1/4" Orifice (3)	62 06 483	500	850	1,200	1,700	2,500	2,500	2,500
1-1/4" Fisher CS400IR 1/4" Orifice (9)	62 06 483	710	900	1,200	1,600	2,300	3,200	4,400
1" X 1" Itron CL31N 1/4" Orifice (4)(7)	62 06 487	800	1450	1750	2,100	2,800	3400 (10)	4000 (10)
2" Fisher CS826-IQ 3/8" Orifice (5)	62 06 485	1,100	1,840	2,560	3,290	4,680	6,730	10,580
2" Fisher CS826-IQ 1/2" Orifice (5)	62 06 149	1,530	2,260	3,760	4,930	8,120	11,580	16,950
2" Fisher 299H 3/8" Orifice, (6) (7)	Non-stock	2,100	3,340	4,360	5,150	6,640	8,120	11,090

UNCONTROLLED IF PRINTED

2" Fisher 299H 1/2" Orifice (8)	(6)	Non-stock	3,640	5,810	7,580	8,960	11,540	14,120	19,280
---------------------------------	-----	-----------	-------	-------	-------	-------	--------	--------	--------

Regulator Capacities (SCFH)					
Regulator Type	Stock No.	Minimum Distribution Pressure			
		80 psig	100 psig	125 psig	
3/4" X 1" Itron B42R 3/16" Orifice, 1-2 psig (2)	62 06 173	Contact GTE	Contact GTE	Contact GTE	
3/4" X 1" American 1813C 3/16" Orifice (3)	62 06 173	Contact GTE	Contact GTE		
3/4" X 1" Itron B42R 1/4" Orifice, 1-2 psig (2) (7)	62 06 482				
3/4" X 1" American 1813C 1/4" Orifice (3)	62 06 482				
1" x 1" Itron B42R 3/16" Orifice, 1-2 psig (2)	62 06 486	Contact GTE	Contact GTE	Contact GTE	
1" X 1" American 1813C 3/16" Orifice (3)	62 06 486	Contact GTE	Contact GTE		
1-1/4" American 1813C 1/4" Orifice (3)	62 06 483	Contact GTE			
1-1/4" Fisher CS400IR 1/4" Orifice (9)	62 06 483	Contact GTE	Contact GTE	Contact GTE	
1" X 1" Itron CL31N 1/4" Orifice (4) (7)	62 06 487	Contact GTE	Contact GTE	Contact GTE	
2" Fisher CS826-IQ 3/8" Orifice (5)	62 06 485	Contact GTE	Contact GTE	Contact GTE	
2" Fisher CS826-IQ 1/2" Orifice (5)	62 06 149	Contact GTE	Contact GTE		
2" Fisher 299H 3/8" Orifice (6) (7) (8)	Non-stock	Contact GTE	Contact GTE	Contact GTE	
2" Fisher 299H 1/2" Orifice (6) (8)	Non-stock	Contact GTE	Contact GTE	Contact GTE	

(Shaded area with no capacity indicates max operating inlet pressure is exceeded for a given orifice.)

Notes:

- (1) Capacities are for 0.60 specific gravity gas with a 1% absolute droop. Relief capacities are calculated using 60 psig inlet and 6 psig customer MEP.
- (2) Itron B42R use Main Spring (Yellow/Black), 1 to 2 psig, set 2 psig,
- (3) American 1813C use Main Spring 70017P049 (Red - Red), 42" w.c. to 2.0 psig range, set 2 psig with no vent pipe.
- (4) Itron CL31N use Pilot Spring 762639 (Blue), 1 to 20 psig, set 2 psig.
- (5) Fisher CS826-IQ use Main Spring GE30342X012 (Blue), 1 to 2.5 psig, set 2 psig, Internal Relief Set Point 2.25 - 4 psig. Maximum buildup 4.4 psig.
- (6) Fisher 299H use Pilot Spring T13593T0012 (Light Blue), 1 to 3.25 psig, set 2 psig.
- (7) Use 1" Fisher 289H Relief Valve with 1D892327022 Spring, 4 to 15 psig, set 4 psig, maximum buildup 6 psig, and capacity 15 MCF. (Stock No. 39 22 034)
- (8) Use 2" Fisher 289H relief valve with 1B536927052 Spring (Red Stripe), 4 to 10 psig, set 4 psig, maximum buildup 6 psig, capacity 30 MCF. (Stock No. 39 10 398)
- (9) Fisher CS400IR use Main Spring GE30190Z012, 1 to 2 psig (Black), set 2 psig
- (10) Itron CL 31N with 1" outlet piping will limit capacity to 3,000 SCFH

Appendix C - Regulators for New Installation @ 5 psig Delivery Pressure

Regulator Capacities (SCFH) (1)									
Regulator Type	Stock No.	Minimum Distribution Pressure							
		10 psig	15 psig	25 psig	40 psig	60 psig	80 psig	100 psig	125 psig
1" X 1" Itron CL31N 1/4" Orifice (2) (3)	62 06 487	1050	1700	2450	3400 (4)	4000 (4)	4000 (4)	4000 (4)	4000 (4)
2" Fisher 299H 1/4" X 3/8" Orifice	Non-stock	1,390 (2)	1,870 (2)	2,570 (2)	3,530 (2)	4,820 (2)	6,110 (2)	7,400 (2)	9,020 (2)
2" Fisher 299H 3/8" Orifice	Non-stock	2,910 (2)	4,190 (2)	5,890 (2)	8,120 (2)	11,090 (2)	Contact GTE	Contact GTE	Contact GTE
2" Fisher 299H 1/2" Orifice	62 06 211	5,050 (2)	7,280 (2)	10,250 (2)	14,120 (2)	19,280 (2)	Contact GTE	Contact GTE	Contact GTE

Notes:

- (1) Capacities are for 0.60 specific gravity gas with 1% absolute droop. Relief capacities are calculated using 60 psig inlet and 10 psig customer MEP.
- (2) Use 1" Fisher 289H Relief Valve with 1D892327022 Spring, 4 to 15 psig, set 7 psig, maximum buildup 10 psig, and capacity 22 MCF. (Stock No. 39 22 034)
- (3) Itron CL31N use pilot spring 762639 (Blue), 1 to 20 psig, set 5 psig.
- (4) Itron CL31N with 1" outlet piping capacity is limited to 3,000 SCFH.

Appendix D - Regulators for New Installation @ 10 psig Delivery Pressure

Regulator Capacities (SCFH) (1)								
Regulator Type	Stock No.	Minimum Distribution Pressure						
		15 psig	25 psig	40 psig	60 psig	80 psig	100 psig	125 psig
1" X 1" Itron CL31N 1/4" Orifice (4)	62 06 487 (2)	1000	2275	3400 (5)	4000 (5)	4000 (5)	4000 (5)	4000 (5)
2" Fisher 299H 1/4" X 3/8" Orifice (2) (3)	Non-stock	1,580	2540	3,530	4,820	6,110 (2)	7,400 (2)	9,020 (2)
2" Fisher 299H 3/8" Orifice (3)	Non-stock (2)	3,280	5710	8,120	11,090	Contact GTE	Contact GTE	Contact GTE
2" Fisher 299H 1/2" Orifice (3)	62 06 211 (2)	5,690	9930	14,120	Contact GTE	Contact GTE	Contact GTE	Contact GTE

Notes:

- (1) Capacities are for 0.60 specific gravity gas with 1% absolute droop. Relief capacities are calculated using 60 psig inlet and 16 psig customer MEP.
- (2) Use 1" Fisher 289H Relief Valve with 1D892327022 Spring, 4 to 15 psig, set 13 psig, maximum buildup 16 psig, and capacity 24.7 MCF. (Stock No. 39 22 034)
- (3) Remove 2.75 to 6 psig (Orange) spring from stock regulator. Install pilot spring (Red), T13600T0012, 5 to 16 psig spring, set 10 psig.
- (4) Itron CL31N use pilot spring 762639 (Blue), 1 to 20 psig, set 10 psig.
- (5) Itron CL31N with 1" outlet piping capacity is limited to 3,000 SCFH.

Appendix E - Alternative Regulator Sizing @ Various Delivery Pressures

Use only when approved manufacturer's regulators are not available.
 Contact Gas Tech Engineering for selection / approval of regulators with capacities > 10,000 CFH and/or inlet pressures > 60 psig.

E-1. 7 Inches w.c.

Regulator Capacities (SCFH) (1)										
Regulator Type	Stock No.	Minimum Distribution Pressure								
		5 psig	10 psig	15 psig	20 psig	30 psig	40 psig	60 psig	80 psig	100 psig
1-1/4" American 1813C-HC, 1/4" Orifice (3) (4)	62 06 175	700	1,100	1,300	1,900	2,500	3,200	(4)		
1 1/4" Itron B31R 1/4" Orifice, 5.5-8.5" Spring (5)	Non-stock	830	1,470	1,570	1,670	2,550	2,600	2,700	2,750	2,770
1 1/4" Itron B31R 3/8" Orifice, 5.5-8.5" Spring (5)	Non-stock	1,400	2,200	2,380	2,560	2,680	2,750	2,930		
1 1/4" Itron B31R 1/2" Orifice, 5.5-8.5" Spring (5)	Non-stock	1,750	2,400	2,525	2,650	2,700	2,760			
2" Itron B34R 1/4" Orifice, 5-8" Spring	Non-stock	1,000 (5)	1,500 (5)	1,825 (5)	2,150 (5)	2,750 (5)	3,450 (5)	4,500 (5)	4,900 (5)	7,400 (5)
2" Itron B34R 3/8" Orifice, 5-8" Spring (8)	Non-stock (6)	2,000	3,400	4,200	5,000	6,500	8,000	9,500	10,000	10,000
2" Itron B34R 1/2" Orifice, 5-8" Spring (6) (9)	Non-stock	2,400	3,500	6,000	8,500	10,000	10,000	10,000		
2" Itron B34R 3/4" Orifice, 5-8"	Non-stock	6,800	10,000	10,000	10,000	10,000	10,000	10,000		

UNCONTROLLED IF PRINTED

Spring (10)	(6)																
----------------	-----	--	--	--	--	--	--	--	--	--	--	--	--	--	--	--	--

(Shaded area shows where max operating inlet pressure is exceeded for a given orifice.)

Notes:

- (1) Capacities are for 0.60 specific gravity gas with 1% absolute droop. Relief capacities are calculated using 60 psig inlet and 2 psig customer MEP.
- (2) All regulators set at 7" w.c. with no vent pipe.
- (3) Use 70017P044 Regulator Spring (yellow), 5.5" to 8.5" w.c. range, set 7" w.c. with no vent pipe.
- (4) *Do not exceed 48 psig MAOP inlet pressure* (Limited by internal relief capacity). For MAOP greater than 48 psig: Use 1" Fisher 289L Relief Valve with 13A7916X012 Spring, range 12" to 40" w.c., setting 14" w.c., maximum buildup 2 psig, and capacity 8 MCF. (Stock Code 39 22 037)
- (5) Use 1" Fisher 289L Relief Valve with 13A7916X012 Spring, range 12" to 40" w.c., setting 14" w.c., maximum buildup 2 psig, and capacity 8 MCF. (Stock Code 39 22 037)
- (6) Use 2" Fisher 289H Relief Valve with 0.5 to 2.25# spring, setting 14" w.c., maximum buildup 2 psig, and capacity 21 MCF. (Stock Code 39 22 048)
- (7) Use 2" Fisher 289P-6365 Relief Valve with 0.5 to 2# spring, setting 14" w.c., maximum buildup 2 psig, and capacity 30.7 MCF. (Stock Code 39 22 095) (spring change required.)
- (8) Do Not exceed 125 psig MAOP Inlet Pressure.
- (9) Do Not exceed 75 psig MAOP Inlet Pressure.
- (10) Do Not exceed 60 psig MAOP Inlet Pressure.

E-2. 2 psig Delivery Pressure

Regulator Capacities (SCFH) (1)											
Regulator Type	Stock No.	Minimum Distribution Pressure (psig)									
		5 psig	10 psig	15 psig	20 psig	30 psig	40 psig	60 psig	80 psig	100 psig	125 psig
1" X 1" American 1813C 1/4" Orifice & (4) (3)	Non-stock	450	750	1,000	1,200	1,700	2,200	2,500			
2" Itron B34R 1/4" Orifice, 1-2 psig Spring	Non-stock	500	1,000	1,025	1,050	2,200	2,700	4,000	4,800	6,400	7,000
2" Itron B34R 3/8" Orifice, 1-2 psig Spring (4)	Non-stock	1,000	1,800	2,050	2,300	3,700	6,000	9,500	12,500	12,800	
2" Itron B34R 1/2" Orifice, 1-2 psig Spring (4)	Non-stock	1,700	2,700	3,950	5,200	7,000	10,800	14,000	16,000	22,000	
2" Itron CL-34-2 1/4" Ori- fice & (6)	Non- (4) stock	800	1,400	1,800	2,100	2,700	3,300	4,600	5,800	7,100	

2" Itron CL-34-2 3/8" Ori- fice & (6)	Non- (4) Stock	2,000	3,300	4,200	4,900	6,300	7,800	10,000	12,800	Con- tact GTE	
2" Itron CL-34-2 1/2" Ori- fice & (6)	Non- (3) Stock	3,500	5,700	7,200	8,500	11,000	13,500	18,500	22,400		

Notes:

- (1) Capacities are for 0.60 specific gravity gas with 1% absolute droop. Relief capacities are calculated using 60 psig inlet and 6 psig customer MEP.
- (2) All regulators set 2 psig with no vent pipe.
- (3) Use 70017P049 regulator spring, 42" w.c. to 2.0 psig range, setting 2 psig with no vent pipe.
- (4) Use 1" Fisher 289H Relief Valve with 1D892327022 Spring, 4 to 15 psig, setting 4 psig, maximum buildup 6 psig, and capacity 15 MCF. (Stock No. 39 22 034)
- (5) Use 2" Fisher 289H relief valve with 1B536927052 spring, 4 to 10 psig, setting 4 psig, maximum buildup 6 psig, capacity 30 MCF. (Stock No. 39 10 398)
- (6) **Itron** CL-34-2 with BROWN main closing spring, GREEN pilot spring, 1.5 to 10 psig control range, set 2 psig.

E-3. 5 psig Delivery Pressure

Regulator Capacities (SCFH) (1)										
Regulator Type	Stock No.	Minimum Distribution Pressure (psig)								
		10 psig	15 psig	20 psig	30 psig	40 psig	60 psig	80 psig	100 psig	125 psig
2" Itron CL-34-2 1/4" Orifice (3) & (4)	Non-stock	1,200	1,700	2,100	2,700	3,300	4,600	5,800	7,100	
2" Itron CL-34-2 3/8" Orifice (3) & (4)	Non-stock	2,800	4,000	4,900	6,300	7,800	10,000	12,800	16,000	
2" Itron CL-34-2 1/2" Orifice (3) & (4)	Non-stock	4,900	6,900	8,500	11,000	13,500	18,500	22,400		

Notes:

- (1) Capacities are for 0.60 specific gravity gas with 1% absolute droop. Relief capacities are calculated using 60 psig inlet and 10 psig customer MEP.
- (2) All regulators set 5 psig.
- (3) **Itron** CL-34-2 with BROWN main closing spring, GREEN pilot spring, 1.5- to 10 psig control range, set 5 psig.
- (4) Use 1" Fisher 289H Relief Valve with 1D892327022 Spring, 4 to 15 psig, setting 7 psig, maximum buildup 10 psig, and capacity 22 MCF. (Stock No. 39 22 034)

E-4. 10 psig Delivery Pressure

Regulator Capacities (SCFH) (1)		
Regulator Type	Stock No	Minimum Distribution Pressure (psig)

UNCONTROLLED IF PRINTED

		15 psig	20 psig	30 psig	40 psig	60 psig	80 psig	100 psig	125 psig
2" Itron CL-34-2 1/4" Ori- fice (3) & (4)	Non- stock	1,300	1,900	2,700	3,300	4,600	5,800	7,100	
2" Itron CL-34-2 3/8" Ori- fice (3) & (4)	Non- stock	3,100	4,500	6,300	7,800	10,000	12,800	16,000	
2" Itron CL-34-2 1/2" Ori- fice (3) & (4)	Non- stock	5,500	7,800	11,000	13,500	18,500	22,400		

Notes:

- (1) Capacities are for 0.60 specific gravity gas with 1% absolute droop. Relief capacities are calculated using 60 psig inlet and 16 psig customer MEP.
- (2) All regulators set 10 psig.
- (3) Itron CL-34-2 with BROWN main closing spring, GREEN pilot spring, 1.5 to 10 psig control range, set 10 psig.
- (4) Use 1" Fisher 289H Relief Valve with 1D892327022 Spring, 4 to 15 psig, setting 13 psig, maximum buildup 16 psig, and capacity 24.7 MCF. (Stock No. 39 22 034)

End of Appendices

METERING

April 1, 2023

METR 3.3 Diaphragm Meter Sets

1.0 Purpose

This document provides the standard designs for various diaphragm meter sets as approved and used by Ameren Illinois (AIC).

2.0 Scope

This document addresses the following:

[3.0 Target Audience](#)

[4.0 Diaphragm Meter Sets](#)

Appendices

(See [Section 4.0](#) for List of Appendices A thru K (11 total))

3.0 Target Audience

- Gas Engineering
- Gas Supervisors
- Gas Field Personnel
- Supervisor Illinois Meter Shops

4.0 Diaphragm Meter Sets

The following list summarizes the respective appendices as attached showing 1) the approved standard drawings, 2) related bills-of-material, and 3) instructions for installing the diaphragm meter sets:

[Appendix A](#) - 175/250 Meter, 7" w.c. Delivery, 1-60 psig Inlet

[Appendix B](#) - 175/250 Meter, 2 psig Delivery, 5-60 psig Inlet

[Appendix C](#) - 175/250 Meter, 7" w.c. Delivery, 61-125 psig Inlet

[Appendix D](#) - 175/250 Meter, 2 psig Delivery, 61-125 psig Inlet

[Appendix E](#) - 425 Meter, 7" w.c. Delivery, 1-60 psig Inlet

[Appendix F](#) - 425 Meter, Bypass, 7" w.c. Delivery, 1-60 psig Inlet

[Appendix G](#) - 425 Meter, Bypass, 2 & 5 psig Delivery, 15-60 psig Inlet

[Appendix H](#) - 630 Meter, 7" w.c. Delivery, 1-60 psig Inlet

[Appendix I](#) - 630 Meter, Bypass, 7" w.c. Delivery, 1-60 psig Inlet

[Appendix J](#) - 630 Meter, Bypass, 2, 5, & 10 psig Delivery, 5-60 psig Inlet

[Appendix K](#) - Multiple Meter Installation

End of Instructions.

Operator Qualification (OQ) Required?

NO.

Appendices

UNCONTROLLED IF PRINTED

See [Section 4.0](#) for list of Appendices A thru K (11 total).

Attachments

NONE.

Compliance Requirements

NONE.

Reference Documents

NONE.

Document Rescission

METR 3.3 Diaphragm Meter Sets – October 1, 2022

Revision Notes

Location of Changes	Summary of Changes
Appendix A through D – 175/250 Meter	Grammatical correction only' Material Lists – Item 3 – CCV replaced CVV Installation – 1. CCV replaced CVV

Appendix A - 175/250 Meter, 7" w.c. Delivery, 1-60 psig Inlet

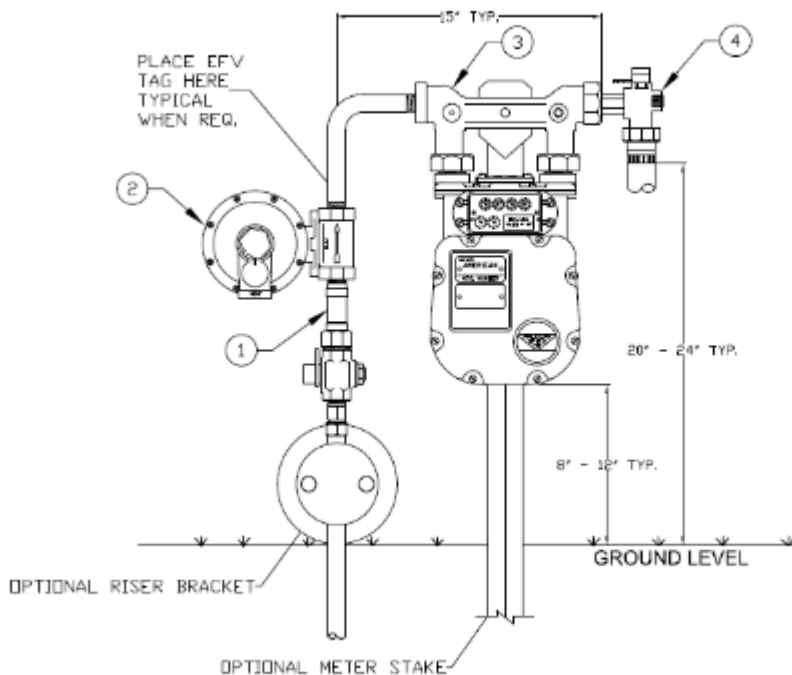

Assembly Number: G4111 ##			
Item	Stock No.	Description	Quantity

UNCONTROLLED IF PRINTED

			01	02
1	19 83 204	3/4" Nipple, Coated, 3" Length	1	
	19 83 200	1" Nipple, Coated, 3" Length		1
2	62 06 187	Regulator, 3/4" FNPT Inlet X 1" FNPT Outlet, Itron B42R or American 1813C, 3/16" Orifice	1	
	62 06 475	Regulator, 1" FNPT Inlet X 1" FNPT Outlet, Itron B42R or American 1813C, 3/16" Orifice		1
3	62 05 161	Bar, Meter, 1" 90-Degree Curved Inlet, 1" Union Outlet with Bypass CCV , 20 Lite Nuts	1	1
	62 05 010	Bar, Meter, 1" 90-Degree Curved Inlet, 1" Union Outlet , 20 Lite Nuts	1(1)	1(1)
4	39 22 632	Valve, Ball, 90-Degree, 3/8" Bypass, 1" Union Nut Inlet x 1" Insulated FNPT Outlet	1(1)	1(1)
	39 01 140	Valve, Plug, Bypass, Straight, 1" FNPT, Non-Insulated, 100 psig, Mueller H-11475, Brisco	1(1)	1(1)

Installation

1. Meter bar, 62 05 161, comes with a bypass **CCV** already installed eliminating the need for the Angle Valve or the Mueller Brisco Valve.
2. Install Angle Valve (Item 4 - 90-Degree Ball Valve) or Mueller Brisco Valve by threading the 1" union nut inlet onto the meter bar.
3. The Angle Valve can be rotated to fit local conditions.
4. Customer piping will be connected to the 1" FNPT outlet.
5. The meter may require additional support. Use a meter stake when conditions do not allow using the riser bracket.
6. The length of the nipple (Item 1) can be altered based on field conditions.
7. Any coating that was damaged during installation shall have paint applied upon completion. See [CORR 2.3, Appendix J](#) for approved paint.
8. The Angle Valve shall be in the closed position for normal operation.
9. Maximum Emergency Pressure (MEP) is 2 psig downstream of meter set.

Appendix B - 175/250 Meter, 2 psig Delivery, 5-60 psig Inlet

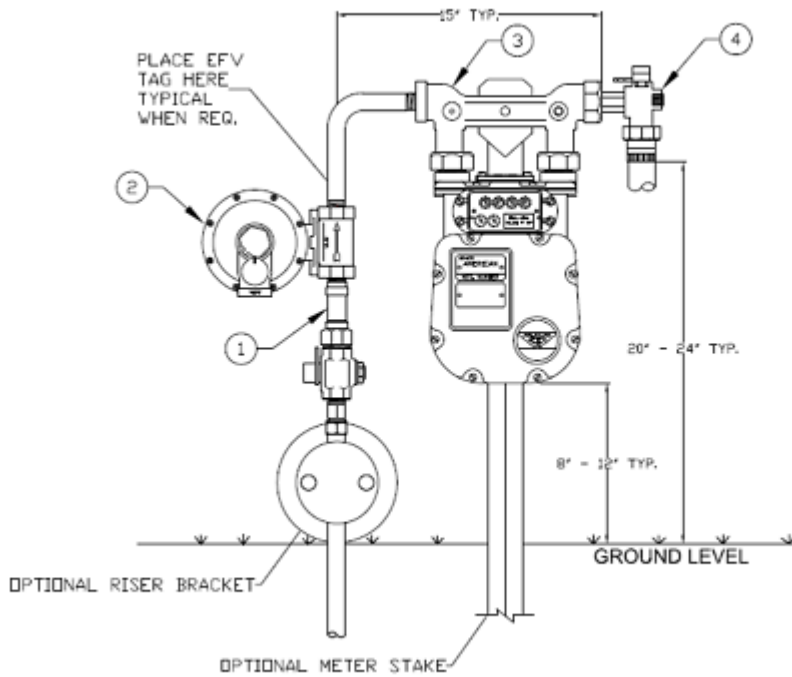

Assembly Number:				
Item	Stock No.	Description	Quantity	
			01	02
1	19 83 204	3/4" Nipple, Coated, 3" Length	1	
	19 83 200	1" Nipple, Coated, 3" Length		1
2	62 06 173	Regulator, 3/4" FNPT Inlet X 1" FNPT Outlet, Itron B42R or American 1813C with 3/16" Orifice	1	
	62 06 486	Regulator, 1" FNPT Inlet x 1" FNPT Outlet, Itron B42R or American 1813C with 3/16" Orifice		1
3	62 05 161	Bar, Meter, 1" 90-Degree Curved Inlet, 1" Union Outlet with Bypass CCV , 20 Lite Nuts	1	1
	62 05 010	Bar, Meter, 1" 90-Degree Curved Inlet, 1" Union Outlet, 20 Lite Nuts	1(1)	1(1)
4	39 22 632	Valve, Ball, 90-Degree, 3/8" Bypass, 1" Union Nut Inlet x 1" Insulated FNPT Outlet	1(1)	1(1)
	39 01 140	Valve, Plug, Bypass, Straight, 1" FNPT, Non-Insulated, 100 psig, Mueller H-11475, Brisco	1(1)	1(1)

Installation

1. Meter bar, 62 05 161, comes with a bypass **CCV** already installed eliminating the need for the Angle Valve or the Mueller Brisco Valve.
2. Install Angle Valve (Item 4 - 90-Degree Ball Valve) or Mueller Brisco Valve by threading the 1" union nut inlet onto the meter bar.
3. The Angle Valve can be rotated to fit local conditions.
4. Customer piping will be connected to the 1" FNPT outlet.
5. The meter may require additional support. Use a meter stake when conditions do not allow using the riser bracket.
6. The length of the nipple (Item 1) can be altered based on field conditions.

UNCONTROLLED IF PRINTED

7. Any coating that was damaged during installation shall have paint applied upon completion. See [CORR 2.3, Appendix J](#) for approved paint.
8. The Angle Valve shall be in the closed position for normal operation.
9. Maximum Emergency Pressure (MEP) is 6 psig downstream of meter set.

Appendix C - 175/250 Meter, 7" w.c. Delivery, 61-125 psig Inlet

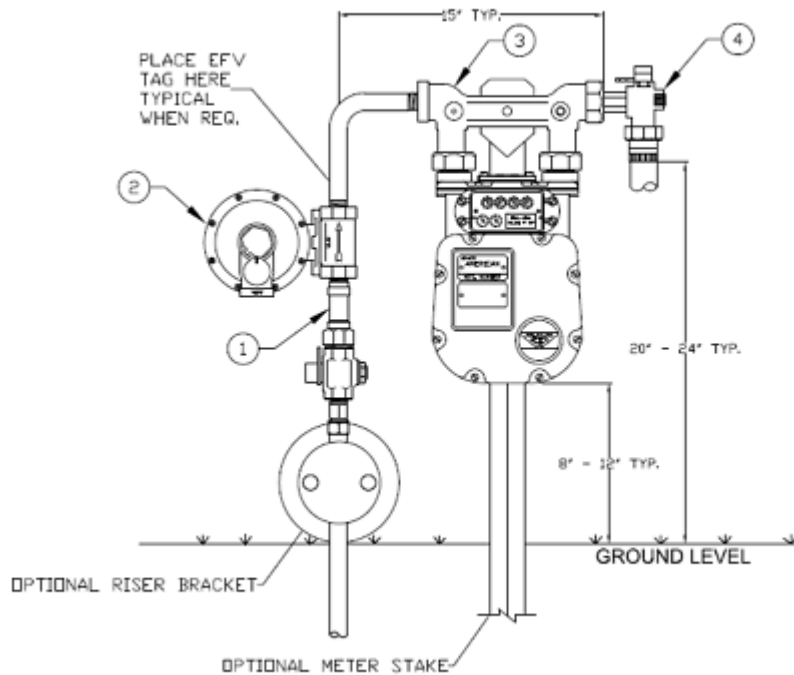

Assembly Number:				
Item	Stock No.	Description	Quantity	
			01	02
1	19 83 204	¾" Nipple, Coated, 3" Length	1	
	19 83 200	1" Nipple, Coated, 3" Length		1
2	62 06 172	Regulator, ¾" FNPT Inlet X 1" FNPT Outlet, Itron B42R, or American 1813C, 1/8"x 3/16" Orifice	1	
	62 06 493	Regulator, 1" FNPT Inlet X 1" FNPT Outlet, Itron B42R or American 1813C, 1/8" x 3/16" Orifice		1
3	62 05 161	Bar, Meter, 1" 90-Degree Curved Inlet, 1" Union Outlet with Bypass CCV , 20 Lite Nuts	1	1
	62 05 010	Bar, Meter, 1" 90-Degree Curved Inlet, 1" Union Outlet, 20 Lite Nuts	1(1)	1(1)
4	39 22 632	Valve, Ball, 90-Degree, 3/8" Bypass, 1" Union Nut Inlet x 1" Insulated FNPT Outlet	1(1)	1(1)
	39 01 140	Valve, Plug, Bypass, Straight, 1" FNPT, Non-Insulated, 100 psig, Mueller H-11475, Brisco	1(1)	1(1)

Installation

1. Meter bar, 62 05 161, comes with a bypass **CCV** already installed eliminating the need for the Angle Valve or the Mueller Brisco Valve.

2. Install Angle Valve (Item 4 - 90-Degree Ball Valve) or Mueller Brisco Valve by threading the 1" union nut inlet onto the meter bar.
3. The Angle Valve can be rotated to fit local conditions.
4. Customer piping will be connected to the 1" FNPT outlet.
5. The meter may require additional support. Use a meter stake when conditions do not allow using the riser bracket.
6. The length of the nipple (Item 1) can be altered based on field conditions.
7. Any coating that was damaged during installation shall have paint applied upon completion. See [CORR 2.3, Appendix J](#) for approved paint.
8. The Angle Valve shall be in the closed position for normal operation.
9. Maximum Emergency Pressure (MEP) is 2 psig downstream of meter set.

Appendix D - 175/250 Meter, 2 psig Delivery, 61-125 psig Inlet

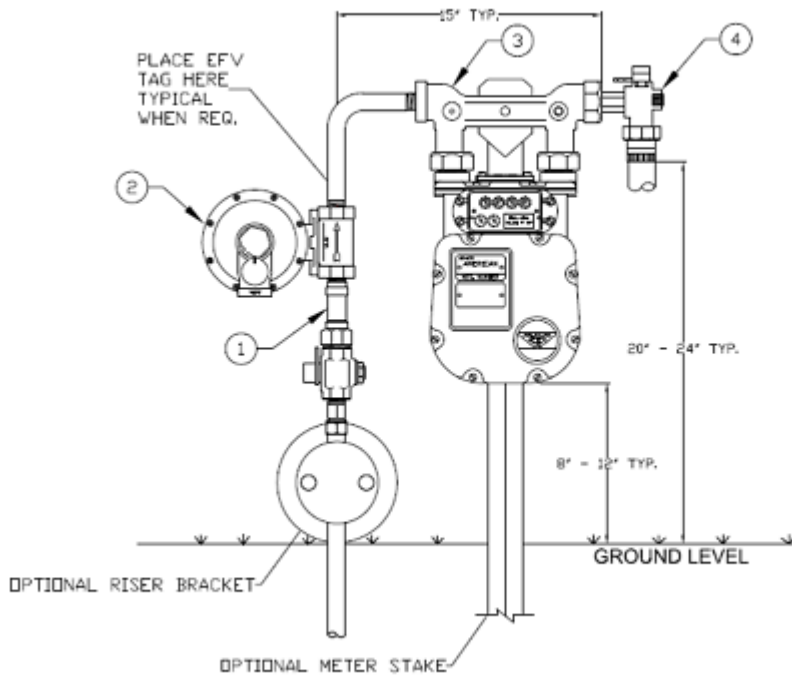

Assembly Number:				
Item	Stock No.	Description	Quantity	
			01	02
1	19 83 204	3/4" Nipple, Coated, 3" Length	1	
	19 83 200	1" Nipple, Coated, 3" Length		1
2	62 06 172	Regulator, 3/4" FNPT Inlet X 1" FNPT Outlet, Itron B42R, or American 1813C, 1/8"x 3/16" Orifice	1	
	62 06 493	Regulator, 1" FNPT Inlet X 1" FNPT Outlet, Itron B42R or American 1813C, 1/8" x 3/16" Orifice		1
3	62 05 161	Bar, Meter, 1" 90-Degree Curved Inlet, 1" Union Outlet with Bypass CCV, 20 Lite Nuts	1	1

UNCONTROLLED IF PRINTED

	62 05 010	Bar, Meter, 1" 90-Degree Curved Inlet, 1" Union Outlet, 20 Lite Nuts	1(1)	1(1)
4	39 22 632	Valve, Ball, 90-Degree, 3/8" Bypass, 1" Union Nut Inlet x 1" Insulated FNPT Outlet	1(1)	1(1)
	39 01 140	Valve, Plug, Bypass, Straight, 1" FNPT, Non-Insulated, 100 psig, Mueller H-11475, Brisco	1(1)	1(1)

Installation

1. Meter bar, 62 05 161, comes with a bypass **CCV** already installed eliminating the need for the Angle Valve or the Mueller Brisco Valve.
2. Install Angle Valve (Item 4 - 90-Degree Ball Valve) or Mueller Brisco Valve by threading the 1" union nut inlet onto the meter bar.
3. The Angle Valve can be rotated to fit local conditions.
4. Customer piping will be connected to the 1" FNPT outlet.
5. The meter may require additional support. Use a meter stake when conditions do not allow using the riser bracket.
6. The length of the nipple (Item 1) can be altered based on field conditions.
7. Any coating that was damaged during installation shall have paint applied upon completion. See [CORR 2.3, Appendix J](#) for approved paint.
8. The Angle Valve shall be in the closed position for normal operation.
9. Maximum Emergency Pressure (MEP) is 6 psig downstream of meter set.

Appendix E - 425 Meter, 7" w.c. Delivery, 1-60 psig Inlet

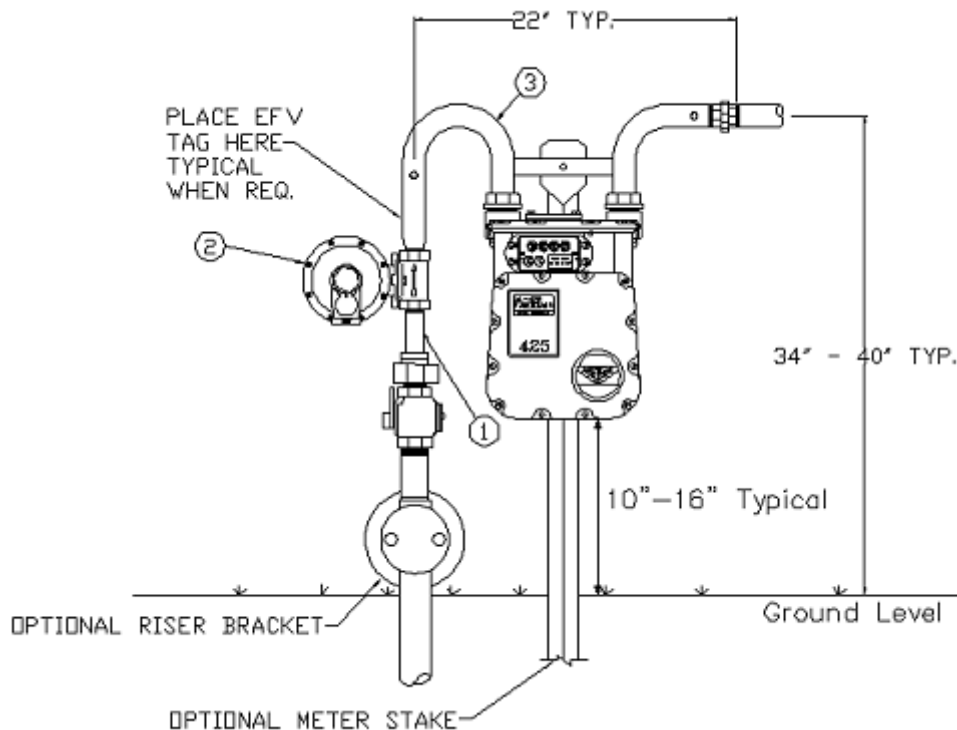

Assembly Number: G4211##				
Item	Stock No.	Description	Quantity	
			01	02
1	19 83 204	3/4" Nipple, Coated, 3" Length	1	

UNCONTROLLED IF PRINTED

	19 83 200	1" Nipple, Coated, 3" Length		1
2	62 06 187	Regulator, 3/4" FNPT Inlet X 1" FNPT Outlet, Itron B42R or American 1813C, 3/16" Orifice	1	
	62 06 475	Regulator, 1" FNPT Inlet X 1" FNPT Outlet, Itron B42R or American 1813C, 3/16" Orifice		1
3	62 05 122	Bar, Meter, 1 1/4" 180-Degree w/ 1" Inlet, 1 1/4" Union Outlet, 30 Lite Nuts	1	

Installation

1. The meter may require additional support. Use a meter stake when conditions do not allow for the use of the riser bracket.
2. The length of the nipple (Item 1) can be altered based on field conditions.
3. Any coating that was damaged during installation shall have paint applied upon completion.
4. Maximum Emergency Pressure (MEP) is 2 psig downstream of meter set.

Appendix F - 425 Meter, Bypass, 7" w.c. Delivery, 1-60 psig Inlet

The bypass option should consider customer's equipment & application.

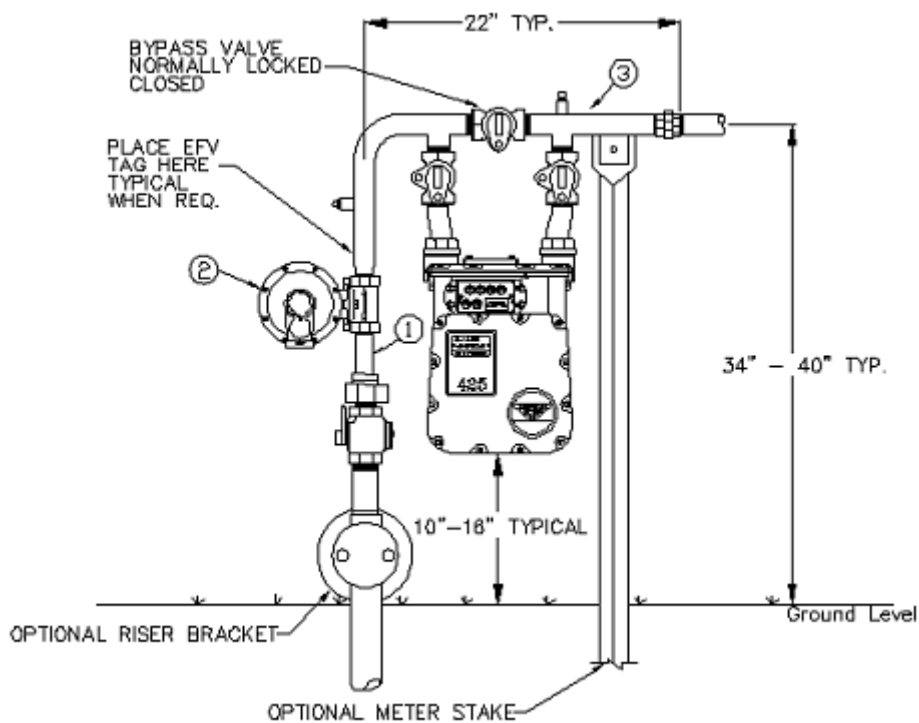

Assembly Number: G4212##				
Item	Stock No.	Description	Quantity	
			01	02
1	19 83 204	3/4" Nipple, Coated, 3" Length	1	
	19 83 200	1" Nipple, Coated, 3" Length		1

2	62 06 187	Regulator, 3/4" FNPT Inlet X 1" FNPT Outlet, Itron B42R or American 1813C, 3/16" Orifice	1	
	62 06 475	Regulator, 1" FNPT Inlet X 1" FNPT Outlet, Itron B42R or American 1813C, 3/16" Orifice		1
3	62 54 370	Bar, Meter, 1-1/4" 90-Degree w/ 1" Inlet, 1-1/4" Union Outlet, Bypass w/ Valves, 30 Lite Nuts	1	

Installation

1. The meter may require additional support. Use a meter stake when conditions do not allow using the riser bracket.
2. The length of the nipple (Item 1) can be altered based on field conditions.
3. Any coating that was damaged during installation shall have paint applied upon completion.
4. The bypass valve shall be locked in the closed position with a barrel lock.
5. Maximum Emergency Pressure (MEP) is 2 psig downstream of meter set.

Appendix G - 425 Meter, Bypass, 2 & 5 psig Delivery, 15-60 psig Inlet

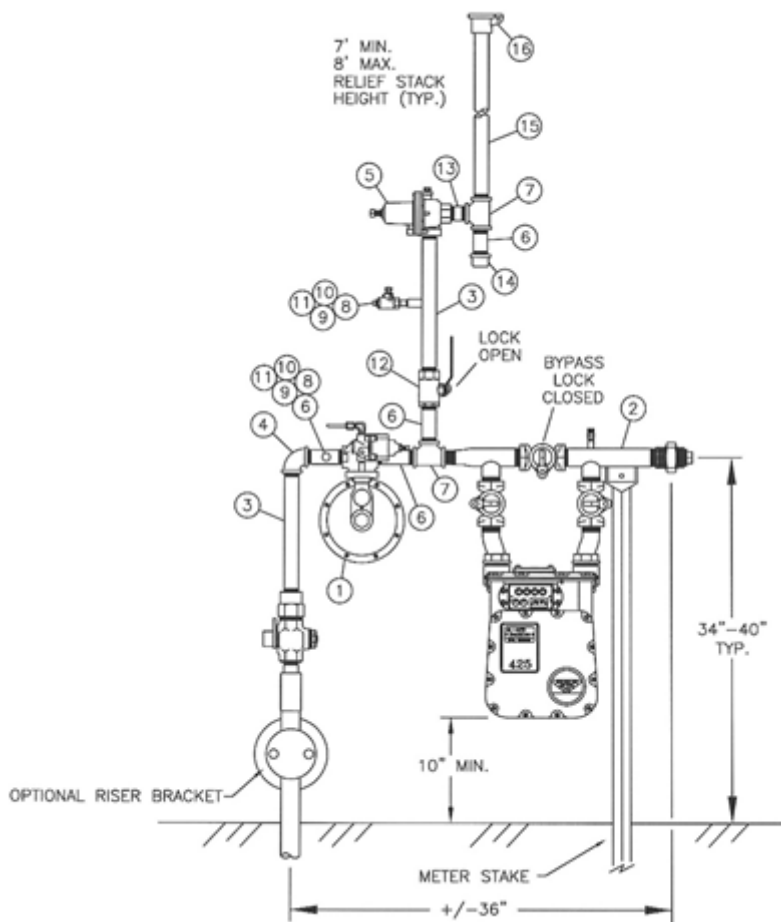

Assembly Number:			
Item	Stock No.	Description	Quantity

UNCONTROLLED IF PRINTED

1	62 06 487	Regulator, 1"x1" Itron CL-31N, 1-20# Spring, Blue, 1/4" Orifice	1
2	62 54 423	Bar, Meter, 1" x 1-1/4" Straight, AL-425 with Bypass, 30LT nuts, 1-1/4" union outlet.	1
3	19 73 480	Nipple, Pipe, Sch 40, MNPT, 1" x 11"	2
4	19 56 047	Elbow, Pipe, 90-Degree, MI, FNPT, 1" x 1"	1
5	39 22 034	Valve, Relief, 1", Fisher 289H, 4-15# Spring, • Set 4 psig for 2 psig Delivery Pressure • Set 7 psig for 5 psig Delivery Pressure	1
6	19 58 103	Nipple, Pipe, Sch 40, MNPT, 1" x 4"	4
7	19 56 111	Tee, Pipe, 1" x 1" x 1", Malleable Iron, FNPT	2
8	19 23 022	Coupling, Pipe, Steel, 3000#, FNPT, 1/4"	2
9	19 73 419	Nipple, Pipe, Sch 40, MNPT, 1/4" x 1 1/2"	2
10	39 22 560	Valve, Ball, 1/4", Bronze, 600#	2
11	19 73 514	Plug, Pipe, Black MI, 1/4", Screw	2
12	39 22 150	Valve, Ball, 1", Bronze, 600#, w/ Locking Device	1
13	19 58 099	Nipple, Pipe, Sch 40, MNPT, 1" x 2"	1
14	19 33 666	Cap, Pipe, FNPT, MI, 150#, 1"	1
15	32 23 306	Pipe, Steel, 1", 0.133 Wall, Black	5 Ft.
16	49 22 026	Cap, Rain, 1", Aluminum	1

Installation

1. See [METR 3.2](#) for regulator sizing information.
2. A rigid service riser should be installed 18" from the building wall.
3. The meter should be adequately supported. A meter stake should be used to support the meter bar. Riser bracket should be used whenever possible. On paved surface, a jack-stand (49-22-067) may be used in place of meter stake.
4. The meter set shall be insulated at the meter valve.
5. Length of 1" x 11" inlet nipple can be altered as required by field conditions.
6. Any coating that was damaged during installation shall have paint applied upon completion.
7. The **BYPASS** valve shall be locked in the **CLOSED** position with a barrel lock.
8. **Relief valve** stack shall be locked in the **OPEN** position.
9. Maximum Emergency Pressure (MEP) downstream of meter set is:
 - 6 psig MEP for 2 psig delivery.
 - 10 psig MEP for 5 psig delivery.

UNCONTROLLED IF PRINTED

Appendix H - 630 Meter, 7" w.c. Delivery, 1-60 psig Inlet

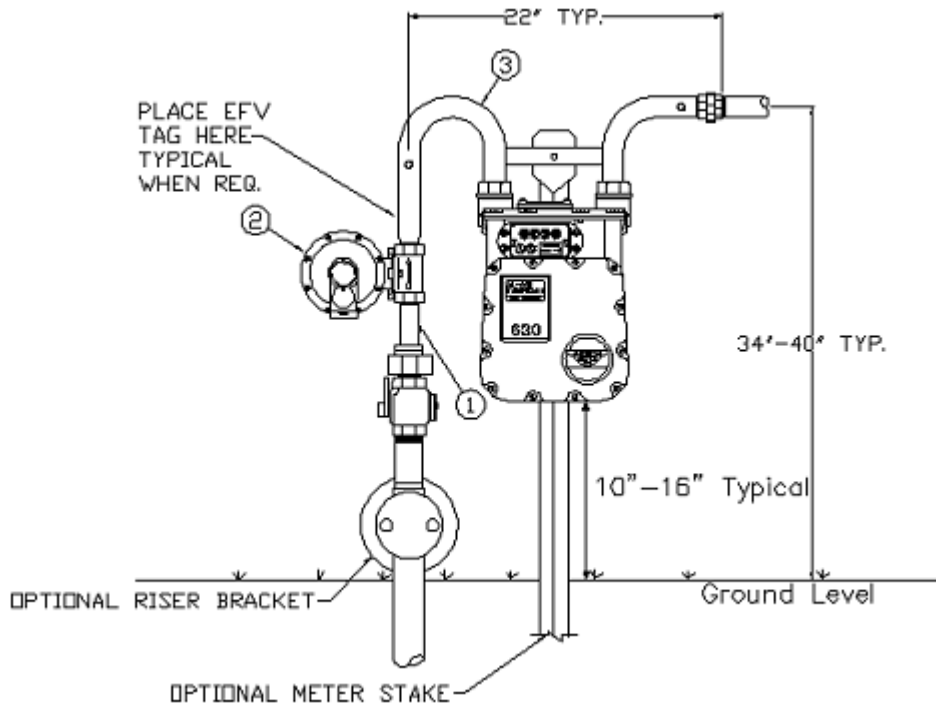

Assembly Number: G4311##				
Item	Stock No.	Description	Quantity	
			01	02
1	19 83 204	3/4" Nipple, Coated, 3" Length	1	
	19 83 200	1" Nipple, Coated, 3" Length		1
2	62 06 187	Regulator, 3/4" FNPT Inlet X 1" FNPT Outlet, Itron B42R or American 1813C, 3/16" Orifice	1	
	62 06 475	Regulator, 1" FNPT Inlet X 1" FNPT Outlet, Itron B42R or American 1813C, 3/16" Orifice		1
3	62 05 119	Bar, Meter, 1-1/4" 180-Degree w/ 1" Inlet, 1-1/4" Union Outlet, 45 Lite Nuts	1	

Installation

1. The meter may require additional support. Use a meter stake when conditions do not allow using the riser bracket.
2. The length of the nipple (Item 1) can be altered based on field conditions.
3. Any coating that was damaged during installation shall have paint applied upon completion.
4. Maximum Emergency Pressure (MEP) is 2 psig downstream of meter set.

Appendix I - 630 Meter, Bypass, 7" w.c. Delivery, 1-60 psig Inlet

The bypass option should consider customer's equipment & application.

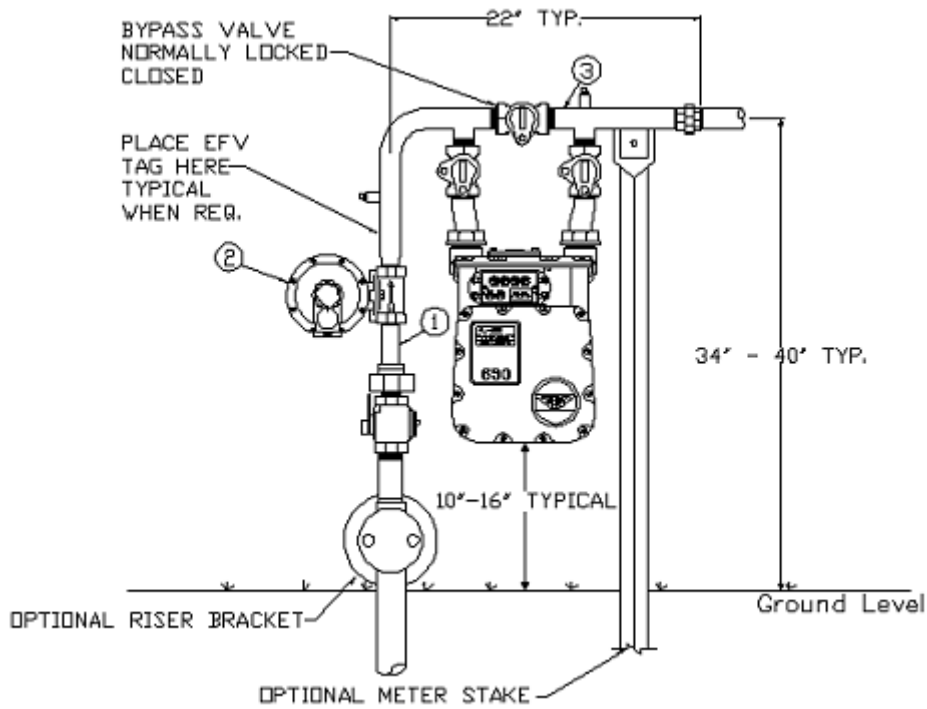

Assembly Number: G4312 ##				
Item	Stock No.	Description	Quantity	
			01	02
1	19 83 204	3/4" Nipple, Coated, 3" Length	1	
	19 83 200	1" Nipple, Coated, 3" Length		1
2	62 06 187	Regulator, 3/4" FNPT Inlet X 1" FNPT Outlet, Itron B42R or American 1813C, 3/16" Orifice	1	
	62 06 475	Regulator, 1" FNPT Inlet X 1" FNPT Outlet, Itron B42R or American 1813C, 3/16" Orifice		1
3	62 54 396	Bar, Meter, 1-1/4" 90-Degree w/ 1" Inlet, 1-1/4" Union Outlet, Bypass w/ Valves, 45 Lite Nuts	1	1

Installation

1. The meter may require additional support. Use a meter stake when conditions do not allow using the riser bracket.
2. The length of the nipple (Item 1) can be altered based upon field conditions.
3. Any coating that was damaged during installation shall have paint applied upon completion.
4. The bypass valve shall be locked in the closed position with a barrel lock.
5. Maximum Emergency Pressure (MEP) is 2 psig downstream of meter set.

Appendix J - 630 Meter, Bypass, 2, 5, & 10 psig Delivery, 15-60 psig Inlet

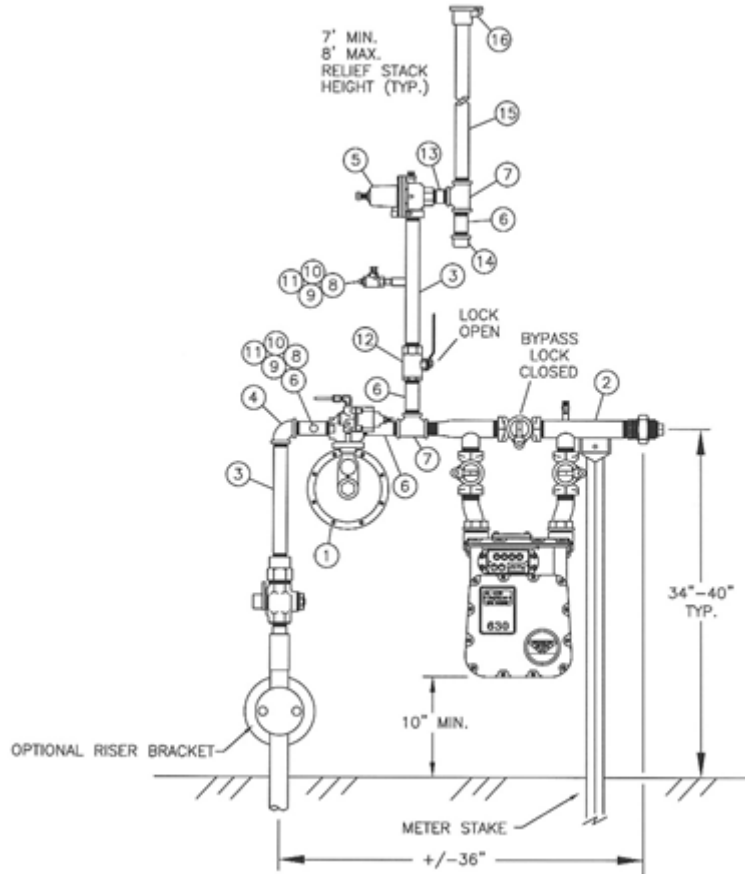

Assembly Number:			
Item	Stock No.	Description	Quantity
1	62 06 487	Regulator, 1"x1" Itron CL-31N, 1-20# Spring, Blue, 1/4" Orifice	1
2	62 54 422	Bar, Meter, 1" x 1-1/4" Straight, AC-630 with Bypass, 45LT nuts, 1-1/4" union outlet.	1
3	19 73 480	Nipple, Pipe, Sch 40, MNPT, 1" x 11"	2
4	19 56 047	Elbow, Pipe, 90-Degree, MI, FNPT, 1" x 1"	1
5	39 22 034	Valve, Relief, 1", Fisher 289H, 4-15# Spring, • Set 4 psig for 2 psig Delivery Pressure • Set 7 psig for 5 psig Delivery Pressure • Set 13 psig for 10 psig Delivery Pressure	1
6	19 58 103	Nipple, Pipe, Sch 40, MNPT, 1" x 4"	4
7	19 56 111	Tee, Pipe, 1" x 1" x 1", Malleable Iron, FNPT	2
8	19 23 022	Coupling, Pipe, Steel, 3000#, FNPT, 1/4"	2
9	19 73 419	Nipple, Pipe, Sch 40, MNPT, 1/4" x 1-1/2"	2
10	39 22 560	Valve, Ball, 1/4", Bronze, 600#	2
11	19 73 514	Plug, Pipe, Black MI, 1/4", Screw	2
12	39 22 150	Valve, Ball, 1", Bronze, 600#, w/ Locking Device	1

UNCONTROLLED IF PRINTED

13	19 58 099	Nipple, Pipe, Sch 40, MNPT, 1" x 2"	1
14	19 33 666	Cap, Pipe, FNPT, MI, 150#, 1"	1
15	32 23 306	Pipe, Steel, 1", 0.133 Wall, Black	5 Ft.
16	49 22 026	Cap, Rain, 1", Aluminum	1

Installation

1. See [METR 3.2](#) for regulator sizing information.
2. A rigid service riser should be installed 18" from the building wall.
3. The meter should be adequately supported. A meter stake should be used to support the meter bar. Riser bracket should be used whenever possible. On paved surface, a jack-stand (49-22-067) may be used in place of meter stake.
4. The meter set shall be insulated at the meter valve.
5. Length of 1" x 11" inlet nipple can be altered as required by field conditions.
6. The **BYPASS** valve shall be locked in the **CLOSED** position with a barrel lock.
7. **Relief valve** stack shall be locked in the **OPEN** position.
8. Maximum Emergency Pressure (MEP) downstream of meter set is:
 - 6 psig MEP for 2 psig delivery.
 - 16 psig MEP for 10 psig delivery.
 - 10 psig MEP for 5 psig delivery.
9. Any coating that was damaged during installation shall have paint applied upon completion.

Appendix K - Multiple Meter Installation

K-1 - 175/250 Class Meter - Single Row

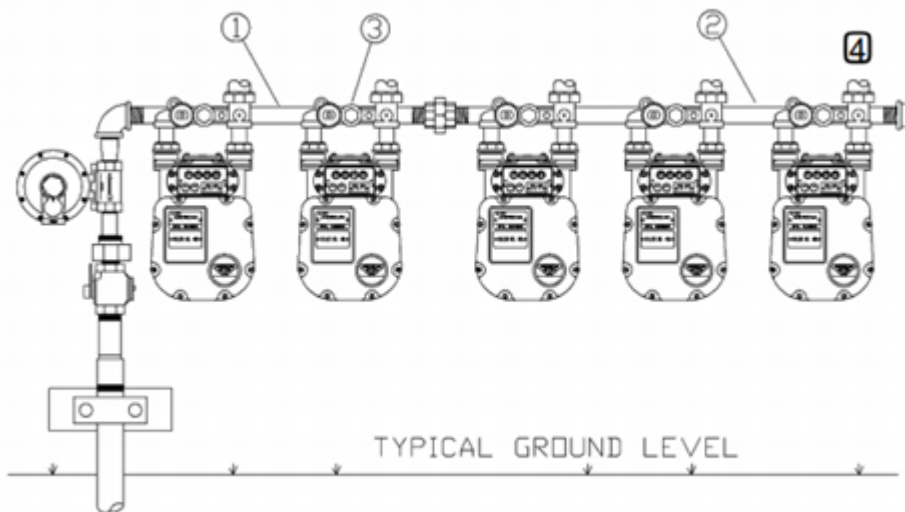

Assembly Number:		
Item	Stock No.	Description

UNCONTROLLED IF PRINTED

1	62 05 021	Header, Multimeter, 1-1/4" x 24" (for two meters)
2	62 05 022	Header, Multimeter, 1-1/4" x 36" (for three meters)
	62 04 321	Header, Multimeter, 1-1/4" x 48" (for four meters)
	62 04 323	Header, Multimeter, 1-1/4" x 72" (for six meters)
3	62 05 011	Bar, Meter, 1" Inlet, 1" Outlet, 20LT, w/ built in valve
4	39 22 632	Valve, Ball, 90-Degree, 3/8" Bypass, 1" Union Nut Inlet x 1" Insulated FNPT Outlet, OR
	39 01 140	Valve, Plug, Bypass, Straight, 1" FNPT, Non-Insulated, 100 psig, Mueller H-11475, Brisco

Installation

1. The regulator and piping up to the header should be sized according to the number of meters and the projected load.
2. All threaded fittings can be replaced with welded fittings.
3. Threaded fittings cannot be back welded.
4. Any coating that was damaged during installation shall have paint applied upon completion.

K-2 - 175/250 Class Meter - Dual Row

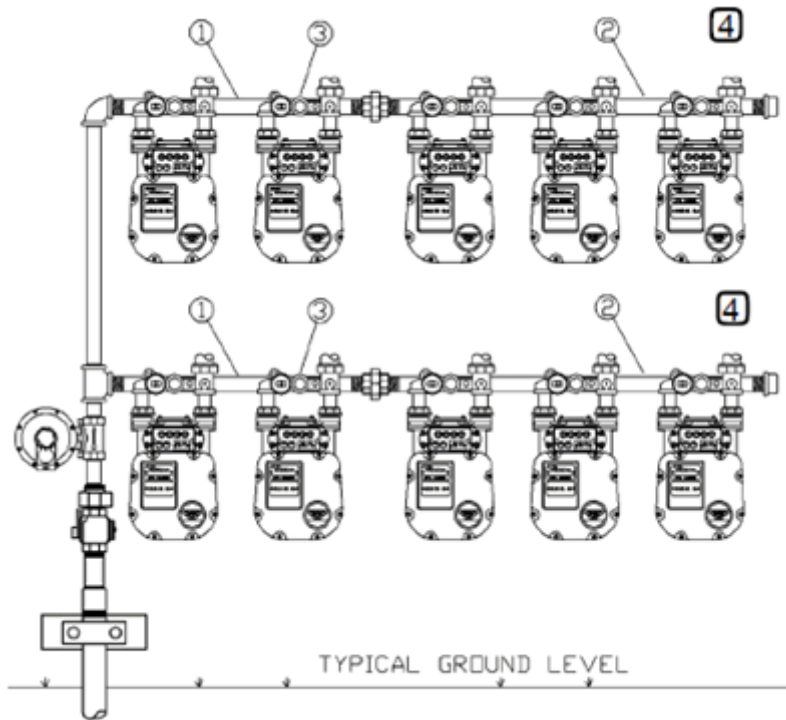

Assembly Number:		
Item	Stock No.	Description
1	62 05 021	Header, Multimeter, 1-1/4" x 24" (for two meters)
2	62 05 022	Header, Multimeter, 1-1/4" x 36" (for three meters)
	62 04 321	Header, Multimeter, 1-1/4" x 48" (for four meters)
	62 04 323	Header, Multimeter, 1-1/4" x 72" (for six meters)
3	62 05 011	Bar, Meter, 1" Inlet, 1" Outlet, 20LT, w/ built in valve
4	39 22 632	Valve, Ball, 90-Degree, 3/8" Bypass, 1" Union Nut Inlet x 1" Insulated FNPT Outlet, OR
	39 01 140	Valve, Plug, Bypass, Straight, 1" FNPT, Non-Insulated, 100 psig, Mueller H-11475, Brisco

UNCONTROLLED IF PRINTED

Installation

See **Installation** notes above under [Section K-1](#).

K-3 - 425 Meter

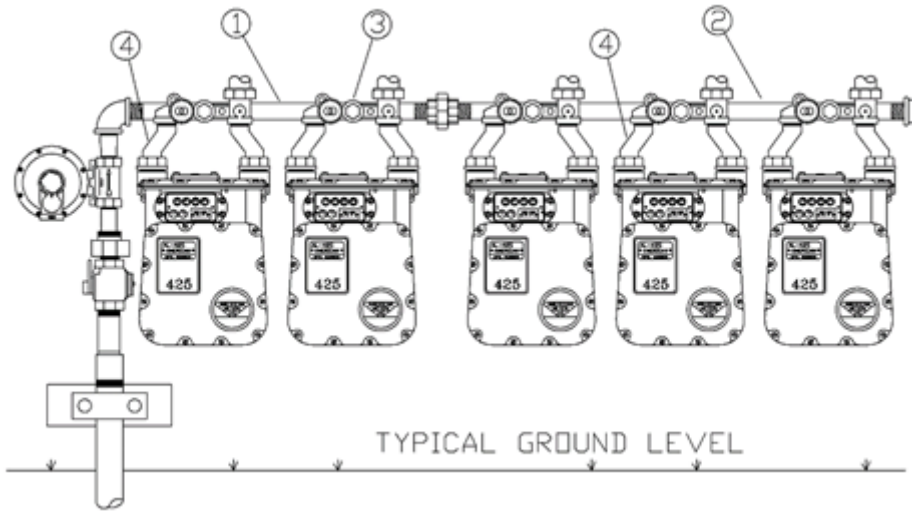

Assembly Number:		
Item	Stock No.	Description
1	62 05 021	Header, Multimeter, 1-1/4" x 24" (for two meters)
2	62 05 022	Header, Multimeter, 1-1/4" x 36" (for three meters)
	62 04 321	Header, Multimeter, 1-1/4" x 48" (for four meters)
	62 04 323	Header, Multimeter, 1-1/4" x 72" (for six meters)
3	62 05 153	Bar, Meter, 1" Inlet, 1" Outlet, w/ built in valve
4	62 54 405	Swivel, Meter, 1", 1-1/4" Offset, 30LT
5	62 54 308	Nut, Meter, 30LT

Installation

See **Installation** notes above under [Section K-1](#).

End of Appendices

METERING

October 1, 2021

METR 3.4 Compact and Rotary Meter Sets

1.0 Purpose

This document provides the standard designs for various compact and rotary meter sets as approved and used by Ameren Illinois .

2.0 Scope

This document addresses the following:

[3.0 Target Audience](#)

[4.0 Appendix List of Gas Meter Sets](#)

Appendices

(See [Section 4.0](#) for List of Appendices A thru H (8 total))

3.0 Target Audience

- Gas Engineering
- Gas Supervisors
- Gas Field Personnel
- Gas Technical Services (GTS) Supervisor
- Gas Meter Supervisor
- Gas Tech Engineering (GTE)

4.0 Appendix List of Gas Meter Sets

The following list summarizes the respective appendices as attached showing 1) the AIC approved standard drawings, 2) related bills-of-material, and 3) instructions for installing the compact and rotary meter sets:

[Appendix A - 15C Compact Meter, 7" w.c. Delivery Pressure](#)

[Appendix B - 15C Compact Meter, 2 psig Delivery Pressure](#)

[Appendix C - 15C/3M Meter, 7" w.c. Delivery Pressure](#)

[Appendix D - 15C/3M Meter, 2 psig Delivery Pressure](#)

[Appendix E - 15C/3M Meter, 5 & 10 psig Delivery Pressure](#)

[Appendix F - 5M/7M Meter, 7" w.c. Delivery Pressure](#)

[Appendix G - 5M/7M Meter, 2 psig Delivery Pressure](#)

[Appendix H - 5M/7M Meter, 5 & 10 psig Delivery Pressure](#)

End of Instructions.

Operator Qualification (OQ) Required?

NO.

Appendices

See [Section 4.0](#) for list of Appendices A thru H (8 total).

Attachments

UNCONTROLLED IF PRINTED

NONE.

Compliance Requirements

NONE.

Reference Documents

NONE.

Document Rescission

METR 3.4 Metering: Compact and Rotary Meter Sets, October 1, 2020

Revision Notes

Location of Changes	Summary of Changes
Appendices A through H	Corrected the 2" Adjustable Pipe Support Length to 22 inches from 21 inches per EMPRV and MRC

Appendix A - 15C Compact Meter, 7" w.c. Delivery Pressure

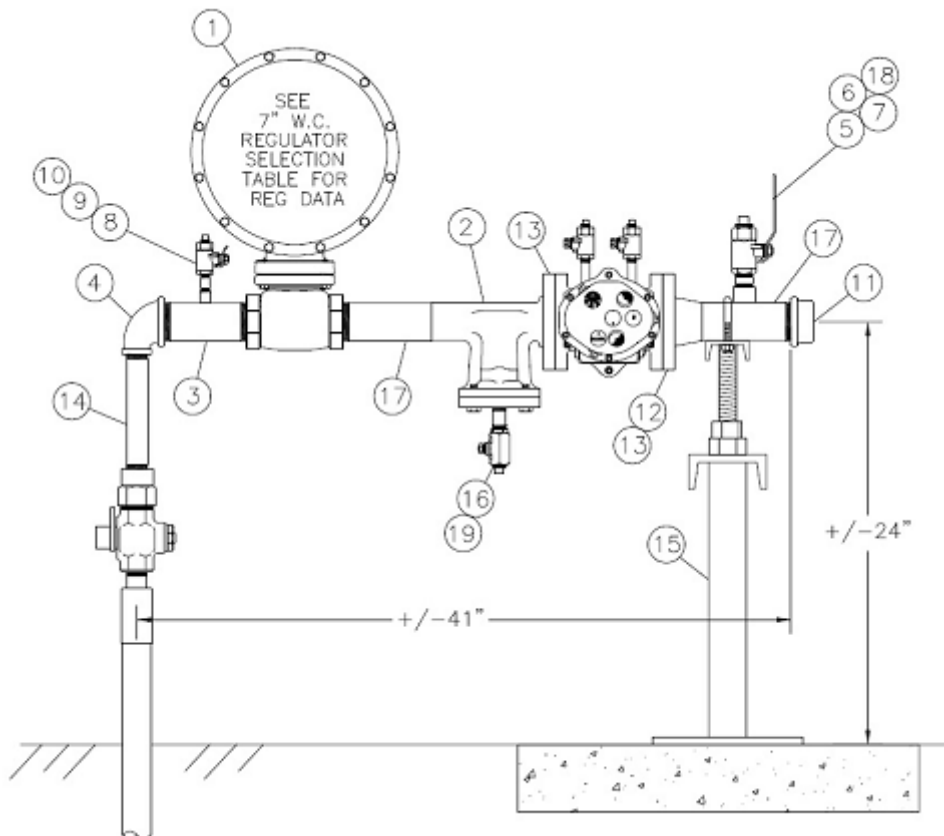

Item	Stock No.	Description	Quantity	
			01	02
1	62 06 180	Regulator, 2", Screwed, Fisher CS806-IQ, 3/8" Orifice	1	1
2	62 05 151	Strainer, Tee, 2", Weld x Flange, 150#, 40-Mesh Filter	1	1
3	19 83 179	Nipple, Pipe, Sch 40, MNPT, 2" x 6", w/ 1/4" Test Port	1	1
4	19 56 474	Elbow, Pipe, 90-Degree, Reducing, MI, FNPT, 2" x 1"	1	
	19 58 486	Elbow, Pipe, 90-Degree, MI, 150", FNPT, 2"		1

UNCONTROLLED IF PRINTED

5	19 58 081	Nipple, Pipe, Sch 40, MNPT, 3/4" x 2"	1	1
6	39 22 139	Valve, Ball, 3/4", Bronze, 600#, w/ Locking Device	1	1
7	19 39 220	Plug, Pipe, Steel, 3000#, MNPT, 3/4"	1	1
8	19 73 419	Nipple, Pipe, Sch 40, MNPT, 1/4" x 1 1/2"	1	1
9	39 22 560	Valve, Ball, 1/4", Bronze, 600#, w/ Locking Device	1	1
10	19 73 514	Plug, Pipe, Steel, 3000#, MNPT, 1/4"	1	1
11	19 33 672	Cap, Pipe, FNPT, MI, 150#, 2"	1	1
12	19 08 420	Flange, Pipe, Weld Neck, 2", 150#, Steel, Flat Face	1	1
13	29 64 487	Gasket, Flange, Ring, 2", 150#, Flat Face	2	2
14	19 58 106	Nipple, Pipe, Sch 40, MNPT, 1" x 6"	1	
	19 58 498	Nipple, Pipe, Sch 40, MNPT, 2" x 6"		1
15	49 22 067	Support, Pipe, 2", Adjustable, 22" Long	1	1
16	19 73 446	Nipple, Pipe, Sch 40, MNPT, 1/2" x 2"	1	1
17	19 73 495	Nipple, Pipe, 2", 6" Long, Threaded One End	2	2
18	19 23 869	Threadolet, 3/4" Outlet, 3000#, Weld x Thread	1	1
19	39 22 232	Valve, Ball, 1/2", Bronze, 600#, w/ Locking Device	1	1

Installation

1. See [METR 3.2](#) for regulator sizing information.
2. Regulator can be oriented in any position provided that the relief vent outlet is pointed downward.
3. A rigid service riser should be installed 18" from the building wall.
4. The meter should be adequately supported. If a stable surface such as a concrete sidewalk or a paved parking lot is not available to support the meter set, a concrete pad or pier should be installed.
5. The meter set shall be insulated at the meter valve.
6. The meter shall be installed using coated bolts provided with the meter. (Dresser Part No. 010044-003, Stock Number 21 54 541)
7. Maximum Emergency Pressure (MEP) is 2 psig downstream of meter set.

Appendix B - 15C Compact Meter, 2 psig Delivery Pressure

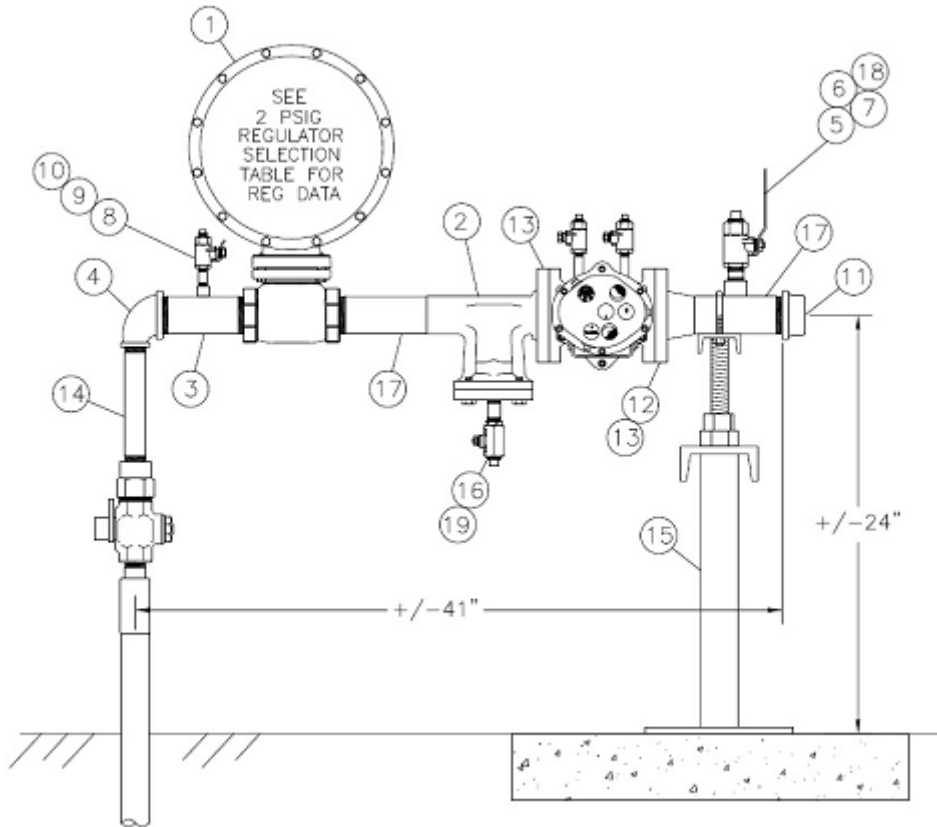

Item	Stock No.	Description	Quantity	
			01	02
1	62 06 485	Regulator, 2", Screwed, Fisher CS826-IQ, 3/8" Orifice	1	1
2	62 05 151	Strainer, Tee, 2", Weld x Flange, 150#, 40-Mesh Filter	1	1
3	19 83 179	Nipple, Pipe, Sch 40, MNPT, 2" x 6", w/ 1/4" Test Port	1	1
4	19 56 474	Elbow, Pipe, 90-Degree, Reducing, MI, FNPT, 2" x 1"	1	
	19 58 486	Elbow, Pipe, 90-Degree, MI, 150", FNPT, 2"		1
5	19 58 081	Nipple, Pipe, Sch 40, MNPT, 3/4" x 2"	1	1
6	39 22 139	Valve, Ball, 3/4", Bronze, 600#, w/ Locking Device	1	1
7	19 39 220	Plug, Pipe, Steel, 3000#, MNPT, 3/4"	1	1
8	19 73 419	Nipple, Pipe, Sch 40, MNPT, 1/4" x 1-1/2"	1	1
9	39 22 560	Valve, Ball, 1/4", Bronze, 600#, w/ Locking Device	1	1
10	19 73 514	Plug, Pipe, Steel, 3000#, MNPT, 1/4"	1	1
11	19 33 672	Cap, Pipe, FNPT, MI, 150#, 2"	1	1
12	19 08 420	Flange, Pipe, Weld Neck, 2", 150#, Steel, Flat Face	1	1
13	29 64 487	Gasket, Flange, Ring, 2", 150#, Flat Face	2	2
14	19 58 106	Nipple, Pipe, Sch 40, MNPT, 1" x 6"	1	
	19 58 498	Nipple, Pipe, Sch 40, MNPT, 2" x 6"		1
15	49 22 067	Support, Pipe, 2", Adjustable, 22 " Long	1	1
16	19 73 446	Nipple, Pipe, Sch 40, MNPT, 1/2" x 2"	1	1
17	19 73 495	Nipple, Pipe, 2", 6" Long, Threaded One End	2	2
18	19 23 869	Threadolet, 3/4" Outlet, 3000#, Weld x Thread	1	1
19	39 22 232	Valve, Ball, 1/2", Bronze, 600#, w/ Locking Device	1	1

Installation

UNCONTROLLED IF PRINTED

1. See [METR 3.2](#) for regulator sizing information.
2. Regulator can be oriented in any position provided that the relief vent outlet is pointed downward.
3. A rigid service riser should be installed 18" from the building wall.
4. The meter should be adequately supported. If a stable surface such as a concrete sidewalk or a paved parking lot is not available to support the meter set, a concrete pad or pier should be installed.
5. The meter set shall be insulated at the meter valve.
6. The meter shall be installed using coated bolts provided with the meter. (Dresser Part No. 010044-003, Stock Number 21 54 541)
7. Maximum Emergency Pressure (MEP) is 6 psig downstream of meter set.

Appendix C - 15C/3M Meter, 7" w.c. Delivery Pressure

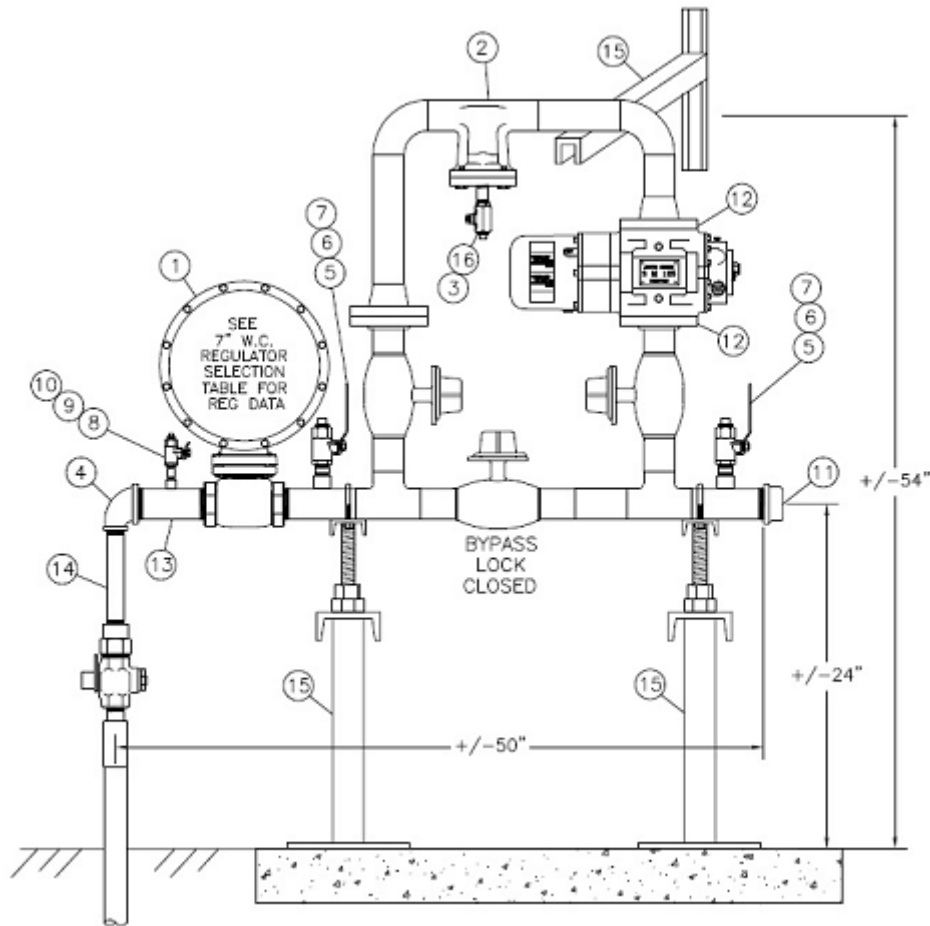

Item	Stock No.	Description	Quantity			
			01	02	03	04
1	62 06 180	Regulator, 2", Screwed, Fisher CS806-IQ, 3/8" Orifice	1	1		
	62 06 151	Regulator, 2", Screwed, Fisher CS806-IQ, 1/2" Orifice			1	1
2	62 05 104	Assembly, Fabricated, Meter, Rotary, 15C/3M, 2"	1	1	1	1
3	19 73 446	Nipple, Pipe, Sch 40, MNPT, 1/2" x 2"	1	1	1	1
4	19 56 474	Elbow, Pipe, 90-Degree, Reducing, MI, FNPT, 2" x 1"	1		1	

UNCONTROLLED IF PRINTED

	19 58 486	Elbow, Pipe, 90-Degree, MI, 150", FNPT, 2"		1		1
5	19 58 081	Nipple, Pipe, Sch 40, MNPT, 3/4" x 2"	2	2	2	2
6	39 22 139	Valve, Ball, 3/4", Bronze, 600#, w/ Locking Device	2	2	2	2
7	19 39 220	Plug, Pipe, Steel, 3000#, MNPT, 3/4"	2	2	2	2
8	19 73 419	Nipple, Pipe, Sch 40, MNPT, 1/4" x 1-1/2"	1	1	1	1
9	39 22 560	Valve, Ball, 1/4", Bronze, 600#, w/ Locking Device	1	1	1	1
10	19 73 514	Plug, Pipe, Steel, 3000#, MNPT, 1/4"	1	1	1	1
11	19 33 672	Cap, Pipe, FNPT, MI, 150#, 2"	1	1	1	1
12	29 64 487	Gasket, Flange, Ring, 2", 150#, Flat Face	2	2	2	2
13	19 83 179	Nipple, Pipe, Sch 40, MNPT, 2" x 6", w/ 1/4" Test Port	1	1	1	1
14	19 58 106	Nipple, Pipe, Sch 40, MNPT, 1" x 6"	1		1	
	19 58 498	Nipple, Pipe, Sch 40, MNPT, 2" x 6"		1		1
15	49 22 067	Support, Pipe, 2", Adjustable, 22" Long	2	2	2	2
16	39 22 232	Valve, Ball, 1/2", Bronze, 600#, w/ Locking Device	1	1	1	1
	Non-Stock	Uni-strut pipe support (or equivalent) - Field Determined	1	1	1	1

Installation

1. See [METR 3.2](#) for regulator sizing information.
2. Regulator can be oriented in any position provided that the relief vent outlet is pointed downward.
3. A rigid service riser should be installed 18" from the building wall.
4. The meter should be adequately supported. If a stable surface such as a concrete sidewalk or a paved parking lot is not available to support the meter set, a concrete pad or piers should be installed.
5. The meter set shall be insulated at the meter valve.
6. The meter shall be installed using coated bolts provided with the meter. (Dresser Part No. 010044-003, Stock Number 21 54 541)
7. Uni-strut bracing (or equivalent) should be installed on the top of meter loop (as shown) when conditions warrant additional lateral support for the meter set.
8. Bypass valve shall be locked in the **Closed** position
9. Maximum Emergency Pressure (MEP) is 2 psig downstream of meter set.

Appendix D - 15C/3M Meter, 2 psig Delivery Pressure

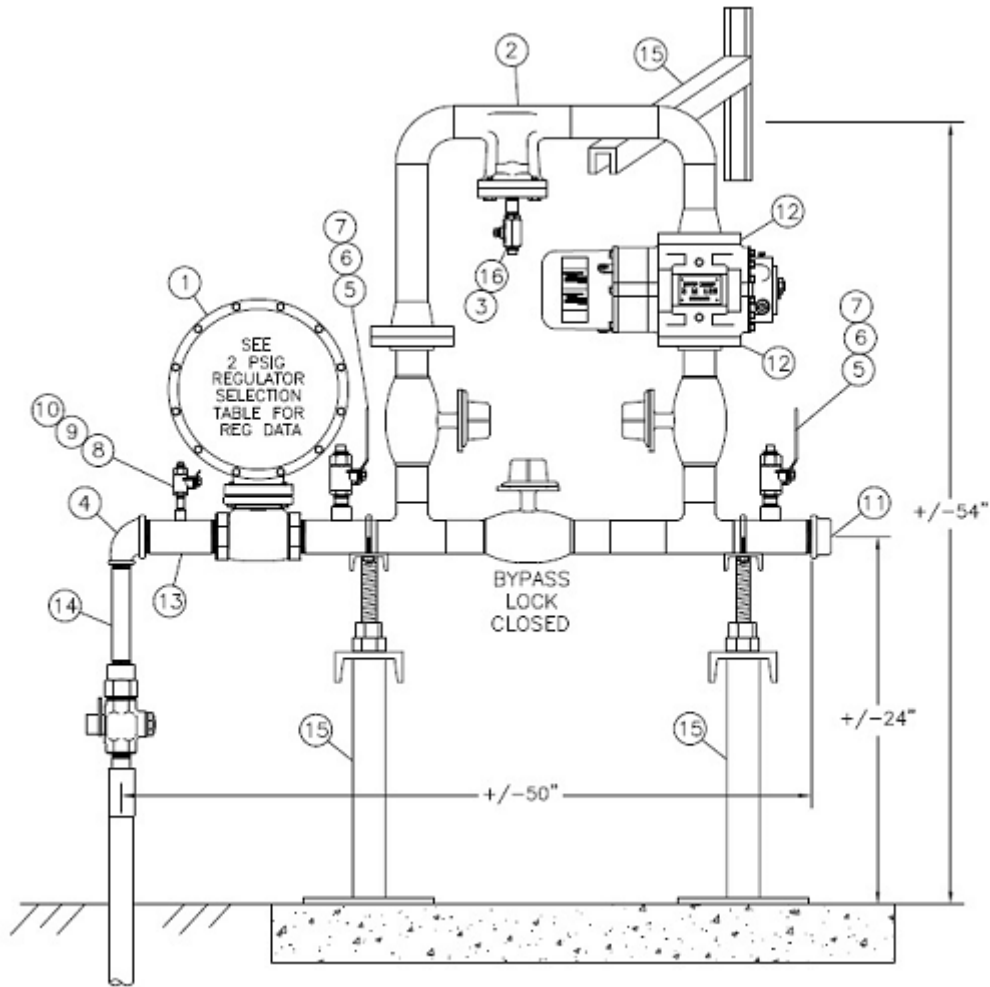

Item	Stock No.	Description	Quantity			
			01	02	03	04
1	62 06 485	Regulator, 2", Screwed, Fisher CS826-IQ, 3/8" Orifice			1	1
	62 06 149	Regulator, 2", Screwed, Fisher CS826-IQ, 1/2" Orifice	1	1		
2	62 05 104	Assembly, Fabricated, Meter, Rotary, 15C/3M, 2"	1	1	1	1
3	19 73 446	Nipple, Pipe, Sch 40, MNPT, 1/2" x 2"	1	1	1	1
4	19 56 474	Elbow, Pipe, 90-Degree, Reducing, MI, FNPT, 2" x 1"	1		1	
	19 58 486	Elbow, Pipe, 90-Degree, MI, 150#, FNPT, 2"		1		1
5	19 58 081	Nipple, Pipe, Sch 40, MNPT, 3/4" x 2"	2	2	2	2
6	39 22 139	Valve, Ball, 3/4", Bronze, 600#, w/ Locking Device	2	2	2	2
7	19 39 220	Plug, Pipe, Steel, 3000#, MNPT, 3/4"	2	2	2	2
8	19 73 419	Nipple, Pipe, Sch 40, MNPT, 1/4" x 1 1/2"	1	1	1	1
9	39 22 560	Valve, Ball, 1/4", Bronze, 600#, w/ Locking Device	1	1	1	1
10	19 73 514	Plug, Pipe, Steel, 3000#, MNPT, 1/4"	1	1	1	1
11	19 33 672	Cap, Pipe, FNPT, MI, 150#, 2"	1	1	1	1
12	29 64 487	Gasket, Flange, Ring, 2", 150#, Flat Face	2	2	2	2
13	19 83 179	Nipple, Pipe, Sch 40, MNPT, 2" x 6", w/ 1/4" Test Port	1	1	1	1
14	19 58 106	Nipple, Pipe, Sch 40, MNPT, 1" x 6"	1		1	
	19 58 498	Nipple, Pipe, Sch 40, MNPT, 2" x 6"		1		1
15	49 22 067	Support, Pipe, 2", Adjustable, 22" Long	2	2	2	2

UNCONTROLLED IF PRINTED

16	39 22 232	Valve, Ball, 1/2", Bronze, 600#, w/ Locking Device	1	1	1	1
	Non-Stock	Uni-strut pipe support (or equivalent) - Field Determined	1	1	1	1

Installation

1. See [METR 3.2](#) for regulator sizing information.
2. Regulator can be oriented in any position provided that the relief vent outlet is pointed downward.
3. A rigid service riser should be installed 18" from the building wall.
4. The meter should be adequately supported. If a stable surface such as a concrete sidewalk or a paved parking lot is not available to support the meter set, a concrete pad or piers should be installed.
5. If an electronic corrector is required, rotate meter 90-degrees for clearance.
6. The meter set shall be insulated at the meter valve.
7. The meter shall be installed using coated bolts provided with the meter. (Dresser Part No. 010044-003, Stock Number 21 54 541)
8. Uni-strut bracing (or equivalent) should be installed on the top of meter loop (as shown) when conditions warrant additional lateral support for the meter set.
9. Bypass valve shall be locked in the **Closed** position.
10. Maximum Emergency Pressure (MEP) is 6 psig downstream of meter set.

Appendix E - 15C/3M Meter, 5 & 10 psig Delivery Pressure

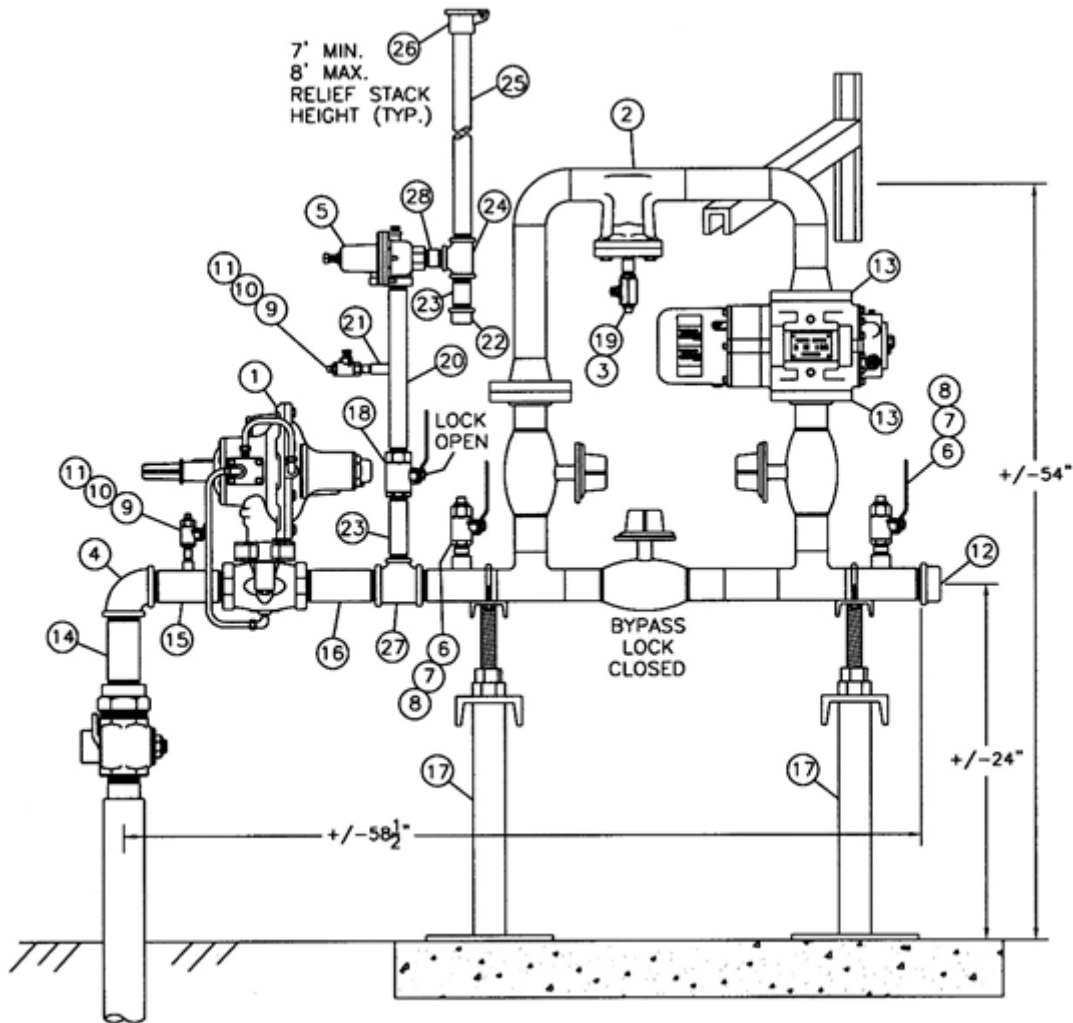

Item	Stock No.	Description	Quantity With	
			1" Riser	2" Riser
1	62 06 211	Regulator, 2", Screwed, Fisher 299H, 1/2" Orifice	1	1
2	62 05 104	Assembly, Fabricated, Meter, Rotary, 15C/3M, 2"	1	1
3	19 73 446	Nipple, Pipe, Sch 40, MNPT, 1/2" x 2"	1	1
4	19 56 474	Elbow, Pipe, 90-Degree, Reducing, MI, FNPT, 2" x 1"	1	
	19 58 486	Elbow, Pipe, 90-Degree, MI, 150", FNPT, 2"		1
5	39 22 034	Valve, Relief, 1", Fisher 289H, 4-15# Spring, • Set 7 psig for 5 psig Delivery Pressure • Set 13 psig for 10 psig Delivery Pressure	1	1
6	19 58 081	Nipple, Pipe, Sch 40, MNPT, 3/4" x 2"	2	2
7	39 22 139	Valve, Ball, 3/4", Bronze, 600#, w/ Locking Device	2	2
8	19 39 220	Plug, Pipe, Steel, 3000#, MNPT, 3/4"	2	2
9	19 73 419	Nipple, Pipe, Sch 40, MNPT, 1/4" x 1 1/2"	2	2

UNCONTROLLED IF PRINTED

10	39 22 560	Valve, Ball, ¼", Bronze, 600#, w/ Locking Device	2	2
11	19 73 514	Plug, Pipe, Steel, 3000#, MNPT, ¼"	2	2
12	19 33 672	Cap, Pipe, FNPT, MI, 150#, 2"	1	1
13	29 64 487	Gasket, Flange, Ring, 2", 150#, Flat Face	2	2
14	19 58 106	Nipple, Pipe, Sch 40, MNPT, 1" x 6"	1	
	19 58 498	Nipple, Pipe, Sch 40, MNPT, 2" x 6"		1
15	19 83 179	Nipple, Pipe, Sch 40, MNPT, 2" x 6", w/ ¼" Test Port	1	1
16	19 58 498	Nipple, Pipe, Sch 40, MNPT, 2" x 6"	1	1
17	49 22 067	Support, Pipe, 2", Adjustable, 22" Long	2	2
18	39 22 150	Valve, Ball, 1", Bronze, 600#, w/ Locking Device	1	1
19	39 22 232	Valve, Ball, ½", Bronze, 600#, w/ Locking Device	1	1
20	19 73 480	Nipple, Pipe, Sch 40, MNPT, 1" x 11"	1	1
21	19 23 022	Coupling, Pipe, Steel, 3000#, FNPT, ¼"	1	1
22	19 33 666	Cap, Pipe, FNPT, MI, 150#, 1"	1	1
23	19 58 103	Nipple, Pipe, Sch 40, MNPT, 1" x 4"	2	2
24	19 56 111	Tee, Pipe, 1" x 1" x 1", Malleable Iron, FNPT	2	2
25	32 23 306	Pipe, Steel, 1", 0.133 Wall, Black	5	5
26	49 22 026	Cap, Rain, 1", Aluminum	1	1
27	19 73 061	Tee, Pipe, 2" x 2" x 1", Malleable Iron, FNPT	1	1
28	19 58 099	Nipple, Pipe, Sch 40, MNPT, 1" x 2"	1	1
	Non-Stock	Uni-strut pipe support (or equivalent) - Field Determined	1	1

Installation

1. See [METR 3.2](#) for regulator sizing information
2. A rigid service riser should be installed 18" from the building wall.
3. The meter should be adequately supported. If a stable surface such as a concrete sidewalk or a paved parking lot is not available to support the meter set, a concrete pad or piers should be installed.
4. If an electronic corrector is required, rotate meter 90-degrees for clearance.

UNCONTROLLED IF PRINTED

5. The meter set shall be insulated at the meter valve.
6. The meter shall be installed using coated bolts provided with the meter.
(Dresser Part No. 010044-003, Stock Number 21 54 541)
7. Uni-strut bracing (or equivalent) should be installed on the top of meter loop (as shown) when conditions warrant additional lateral support for the meter set.
8. **Bypass** valve shall be locked in the **Closed** position.
9. The **relief valve** stack shall be locked in the **Open** position.
10. Maximum Emergency Pressure (MEP) downstream of meter set is:
 - 10 psig MEP for 5 psig delivery
 - 16 psig MEP for 10 psig delivery.

Appendix F - 5M/7M Meter, 7" w.c. Delivery Pressure

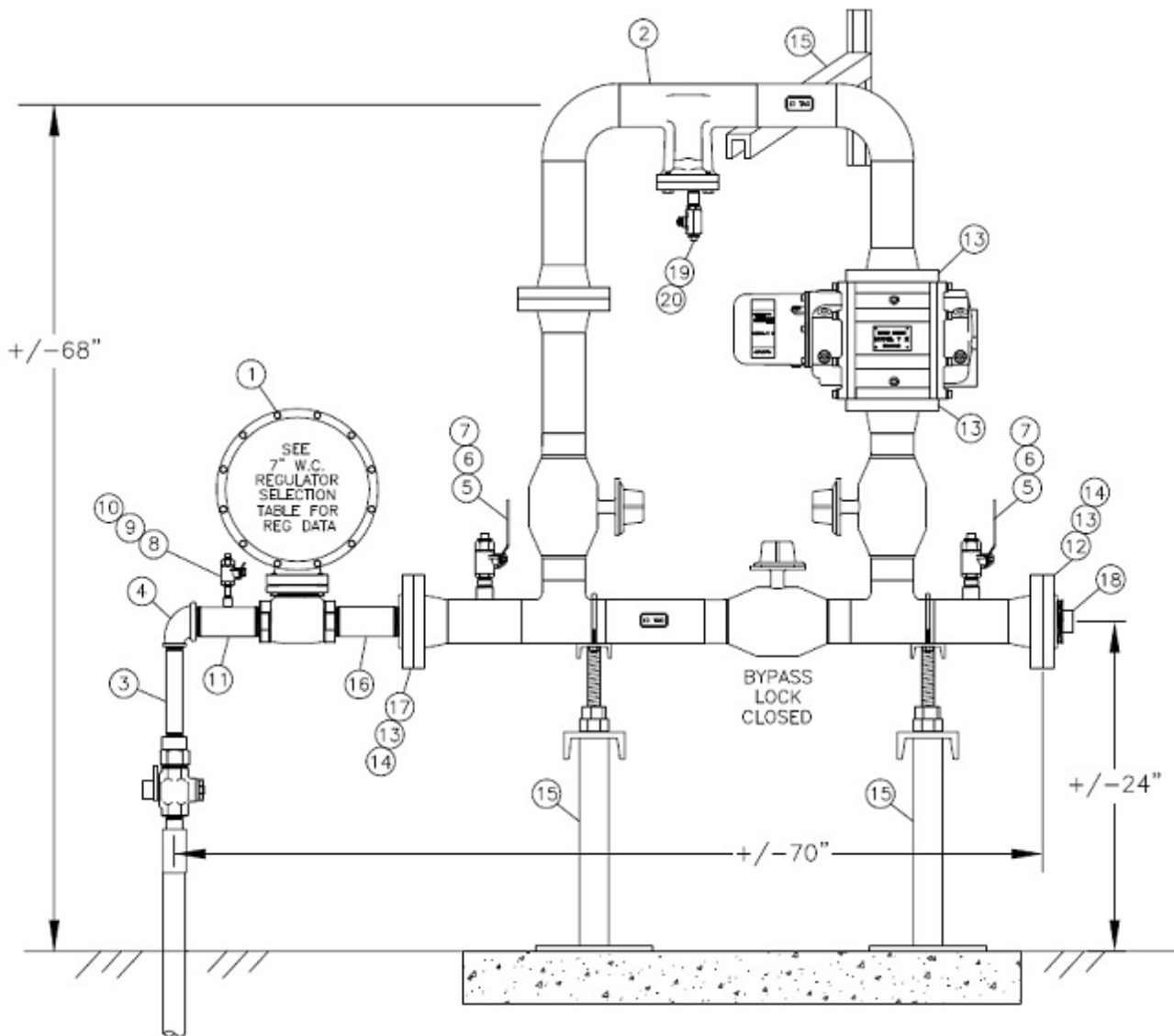

Item	Stock No.	Description	Quantity			
			01	02	03	04
1	62 06 180	Regulator, 2", Screwed, Fisher CS806-IQ, 3/8" Orifice	1	1		
	62 06 151	Regulator, 2", Screwed, Fisher CS806-IQ, 1/2" Orifice			1	1

UNCONTROLLED IF PRINTED

2	62 05 155	Assembly, Fabricated, Meter, Rotary, 5M/7M, 3"	1	1	1	1
3	19 58 106	Nipple, Pipe, Sch 40, MNPT, 1" x 6"	1		1	
	19 58 498	Nipple, Pipe, Sch 40, MNPT, 2" x 6"		1		1
4	19 56 474	Elbow, Pipe, 90-Degree, Reducing, MI, FNPT, 2" x 1"	1		1	
	19 58 486	Elbow, Pipe, 90-Degree, MI, 150", FNPT, 2"		1		1
5	19 58 081	Nipple, Pipe, Sch 40, MNPT, 3/4" x 2"	2	2	2	2
6	39 22 139	Valve, Ball, 3/4", Bronze, 600#, w/ Locking Device	2	2	2	2
7	19 39 220	Plug, Pipe, Steel, 3000#, MNPT, 3/4"	2	2	2	2
8	19 73 419	Nipple, Pipe, Sch 40, MNPT, 1/4" x 1 1/2"	1	1	1	1
9	39 22 560	Valve, Ball, 1/4", Bronze, 600#, w/ Locking Device	1	1	1	1
10	19 73 514	Plug, Pipe, Steel, 3000#, MNPT, 1/4"	1	1	1	1
11	19 83 179	Nipple, Pipe, Sch 40, MNPT, 2" x 6", w/ 1/4" Test Port	1	1	1	1
12	19 23 363	Flange, Pipe, Threaded, 150#, Steel, 3"	1	1	1	1
13	29 64 489	Gasket, Flange, Ring, 3", 150#, Flat Face	4	4	4	4
14	21 56 335	Bolt, Hex Head, 5/8" x 2 1/2", w/ Nut	8	8	8	8
15	49 22 067	Support, Pipe, 2", Adjustable, 22" Long	2	2	2	2
16	19 58 498	Nipple, Pipe, Sch 40, MNPT, 2" x 6"	1	1	1	1
17	19 23 367	Flange, Pipe, Threaded, 150#, 3" x 2"	1	1	1	1
18	19 56 493	Plug, Pipe, MI, 3"	1	1	1	1
19	19 73 446	Nipple, Pipe, Sch 40, MNPT, 1/2" x 2"	1	1	1	1
20	39 22 232	Valve, Ball, 1/2", Bronze, 600#, w/ Locking Device	1	1	1	1
	Non-Stock	Uni-strut pipe support (or equivalent) - Field Determined	1	1	1	1

Installation

1. See [METR 3.2](#) for regulator sizing information.
2. Regulator can be oriented in any position provided that the relief vent outlet is pointed downward.
3. The meter loop accommodates both 5M and 7M meters by rotating the top assembly and the basket of the tee strainer.
4. A rigid service riser should be installed 18" from the building wall.
5. The meter should be adequately supported. If a stable surface such as a concrete sidewalk or a paved parking lot is not available to support the meter set, a concrete pad or piers should be installed.
6. The meter set shall be insulated at the meter valve.
7. The meter shall be installed using coated bolts provided with the meter. (Dresser Part No. 010044-003, Stock Number 21 54 541)
8. Uni-strut bracing (or equivalent) should be installed on the top of the meter loop (as shown) when conditions warrant additional lateral support for the meter set.
9. Bypass valve shall be locked in the **Closed** position.
10. Maximum Emergency Pressure (MEP) is 2 psig downstream of meter set.

Appendix G - 5M/7M Meter, 2 psig Delivery Pressure

UNCONTROLLED IF PRINTED

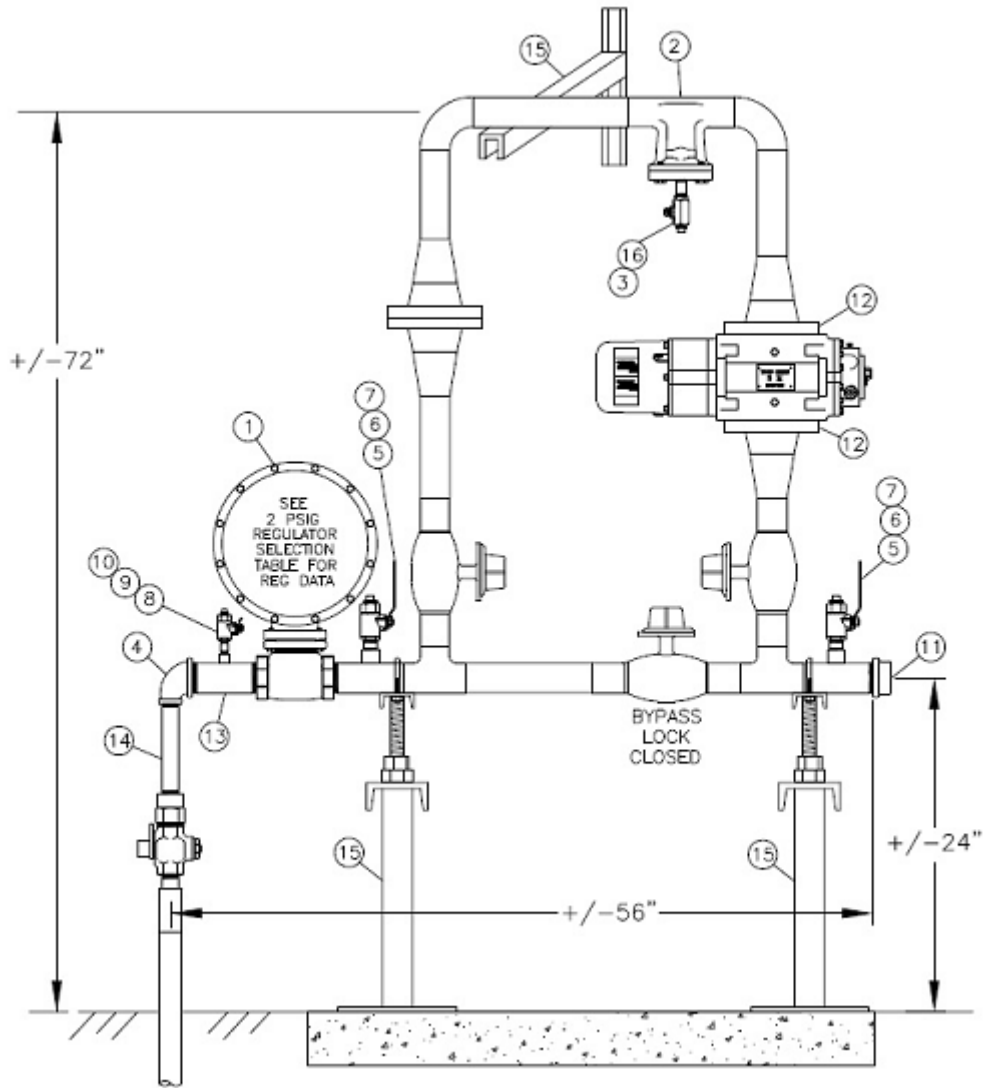

Item	Stock No.	Description	Quantity			
			01	02	03	04
1	62 06 485	Regulator, 2", Screwed, Fisher CS826-IQ, 3/8" Orifice			1	1
	62 06 149	Regulator, 2", Screwed, Fisher CS826-IQ, 1/2" Orifice	1	1		
2	62 05 120	Assembly, Fabricated, Meter, Rotary, 5M/7M, 2"	1	1	1	1
3	19 73 446	Nipple, Pipe, Sch 40, MNPT, 1/2" x 2"	1	1	1	1
4	19 56 474	Elbow, Pipe, 90-Degree, Reducing, MI, FNPT, 2" x 1"	1		1	
	19 58 486	Elbow, Pipe, 90-Degree, MI, 150#, FNPT, 2"		1		1
5	19 58 081	Nipple, Pipe, Sch 40, MNPT, 3/4" x 2"	2	2	2	2
6	39 22 139	Valve, Ball, 3/4", Bronze, 600#, w/Lock	2	2	2	2
7	19 39 220	Plug, Pipe, Steel, 3000#, MNPT, 3/4"	2	2	2	2
8	19 73 419	Nipple, Pipe, Sch 40, MNPT, 1/4" x 1 1/2"	1	1	1	1
9	39 22 560	Valve, Ball, 1/4", Bronze, 600#	1	1	1	1
10	19 73 514	Plug, Pipe, Black MI, 1/4", Screw	1	1	1	1
11	19 33 672	Cap, Pipe, FNPT, MI, 150#, 2"	1	1	1	1
12	29 64 489	Gasket, Flange, Ring, 3", 150#, Flat Face	2	2	2	2
13	19 83 179	Nipple, Pipe, Sch 40, MNPT, 2" x 6", w/ 1/4" Test Port	1	1	1	1
14	19 58 106	Nipple, Pipe, Sch 40, MNPT, 1" x 6"	1		1	

UNCONTROLLED IF PRINTED

	19 58 498	Nipple, Pipe, Sch 40, MNPT, 2" x 6"		1		1
15	49 22 066	Support, Pipe, 2", Adjustable, 22" Long	2	2	2	2
16	39 22 232	Valve, Ball, 1/2", Bronze, 600#, w/ Locking Device	1	1	1	1
	40 89 374	Uni-strut pipe channel, 1-5/8" x 1-5/8" x 10' Long	1	1	1	1

Installation

1. See [METR 3.2](#) for regulator sizing information.
2. Regulator can be oriented in any position provided that the relief vent outlet is pointed downward.
3. The meter loop accommodates both 5M and 7M meters by rotating the top assembly and basket of the tee strainer.
4. A rigid service riser should be installed 18" from the building wall.
5. The meter should be adequately supported. If a stable surface such as a concrete sidewalk or a paved parking lot is not available to support the meter set, a concrete pad or piers should be installed.
6. If an electronic corrector is required, rotate meter 90-degrees for clearance.
7. The meter set shall be insulated at the meter valve.
8. The meter shall be installed using coated bolts provided with the meter. (Dresser Part No. 010044-003, Stock Number 21 54 541)
9. Uni-strut bracing (or equivalent) should be installed on top of the meter loop (as shown) when conditions warrant additional lateral support for the meter set.
10. Bypass valve shall be locked in the **Closed** position.
11. Maximum Emergency Pressure (MEP) is 6 psig downstream of meter set.

Appendix H - 5M/7M Meter, 5 & 10 psig Delivery Pressure

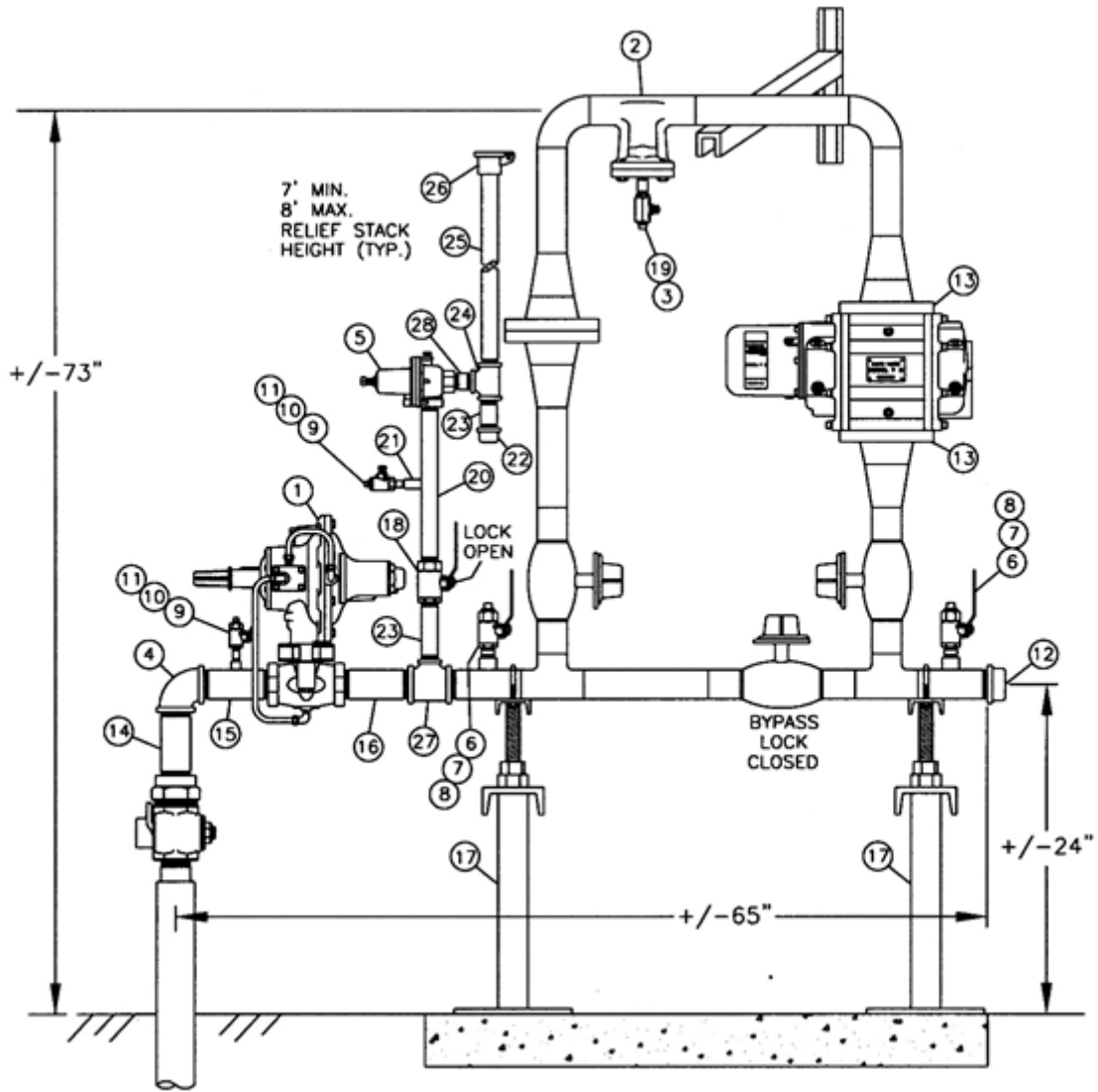

Item	Stock No.	Description	Quantity With	
			1" Riser	2" Riser
1	62 06 211	Regulator, 2", Screwed, Fisher 299H, 1/2" Orifice	1	1
2	62 05 120	Assembly, Fabricated, Meter, Rotary, 5M/7M, 2"	1	1
3	19 73 446	Nipple, Pipe, Sch 40, MNPT, 1/2" x 2"	1	1
4	19 56 474	Elbow, Pipe, 90-Degree, Reducing, MI, FNPT, 2" x 1"	1	
	19 58 486	Elbow, Pipe, 90-Degree, MI, 150", FNPT, 2"		1
5	39 22 034	Valve, Relief, 1", Fisher 289H, 4-15# Spring, • Set 7 psig for 5 psig Delivery Pressure • Set 13 psig for 10 psig Delivery Pressure	1	1
6	19 58 081	Nipple, Pipe, Sch 40, MNPT, 3/4" x 2"	2	2
7	39 22 139	Valve, Ball, 3/4", Bronze, 600#, w/ Locking Device	2	2
8	19 39 220	Plug, Pipe, Steel, 3000#, MNPT, 3/4"	2	2

UNCONTROLLED IF PRINTED

9	19 73 419	Nipple, Pipe, Sch 40, MNPT, ¼" x 1 ½"	2	2
10	39 22 560	Valve, Ball, ¼", Bronze, 600#	2	2
11	19 73 514	Plug, Pipe, Black MI, ¼", Screw	2	2
12	19 33 672	Cap, Pipe, FNPT, MI, 150#, 2"	1	1
13	29 64 489	Gasket, Flange, Ring, 3", 150#, Flat Face	2	2
14	19 58 106	Nipple, Pipe, Sch 40, MNPT, 1" x 6"	1	
	19 58 498	Nipple, Pipe, Sch 40, MNPT, 2" x 6"		1
15	19 83 179	Nipple, Pipe, Sch 40, MNPT, 2" x 6", w/ ¼" Test Port	1	1
16	19 58 498	Nipple, Pipe, Sch 40, MNPT, 2" x 6"	1	1
17	49 22 067	Support, Pipe, 2", Adjustable, 22" Long	2	2
18	39 22 150	Valve, Ball, 1", Bronze, 600#, w/ Locking Device	1	1
19	39 22 232	Valve, Ball, ½", Bronze, 600#, w/ Locking Device	1	1
20	19 73 480	Nipple, Pipe, Sch 40, MNPT, 1" x 11"	1	1
21	19 23 022	Coupling, Pipe, Steel, 3000#, FNPT, ¼"	1	1
22	19 33 666	Cap, Pipe, FNPT, MI, 150#, 1"	1	1
23	19 58 103	Nipple, Pipe, Sch 40, MNPT, 1" x 4"	2	2
24	19 56 111	Tee, Pipe, 1" x 1" x 1", Malleable Iron, FNPT	2	2
25	32 23 306	Pipe, Steel, 1", 0.133 Wall, Black	5	5
26	49 22 026	Cap, Rain, 1", Aluminum	1	1
27	19 73 061	Tee, Pipe, 2" x 2" x 1", Malleable Iron, FNPT	1	1
28	19 58 099	Nipple, Pipe, Sch 40, MNPT, 1" x 2"	1	1
	Non-Stock	Uni-strut pipe support (or equivalent) - Field Determined	1	1

Installation

1. See [METR 3.2](#) for regulator sizing information.
2. The meter loop accommodates both 5M and 7M meters by rotating the top assembly and basket of the tee strainer.
3. A rigid service riser should be installed 18" from the building wall.

UNCONTROLLED IF PRINTED

4. The meter should be adequately supported. If a stable surface such as a concrete sidewalk or a paved parking lot is not available to support the meter set, a concrete pad or piers should be installed.
5. If an electronic corrector is required, rotate meter 90-degrees for clearance.
6. The meter set shall be insulated at the meter valve.
7. The meter shall be installed using coated bolts provided with the meter. (Dresser Part No. 010044-003, Stock Number 21 54 541)
8. Uni-strut bracing (or equivalent) should be installed on top of the meter loop (as shown) when conditions warrant additional lateral support for the meter set.
9. **Bypass valve** shall be locked in the **Closed** position.
10. The **relief valve** stack shall be locked in the **Open** position.
11. Maximum Emergency Pressure (MEP) downstream of meter set is:
 - 10 psig MEP for 5 psig delivery
 - 16 psig MEP for 10 psig delivery

End of Appendices

METERING

October 1, 2022

METR 4 Forms and Reference Materials

Click on the links below to open the documents.

Forms

1. [Electronic Corrector Inspection Form – Fillable \(April 27, 2022\)](#)
2. [Electronic Corrector Verification Form – Fillable \(April 27, 2022\)](#)
3. [Elevated Delivery Pressure Request Form](#)
4. [Gas Meter Data Sheet \(Rev 08-13-2018\)](#)
5. [Ultrasonic Meter Inspection Form - Daniel Meter](#)
6. [Ultrasonic Meter Inspection Form - Instromet Meter](#)
7. [Ultrasonic Meter Inspection Form - Sick Meter](#)

References

- [Appendix A - Meter Test Schedules & Retention Requirements](#) (in support of [METR 2.2](#), [METR 2.3](#), and [METR 2.4](#))

Manufacturer References:

1. [American 1813C Tech Bulletin](#)
2. [A Y McDonald Portable Bypass Kit Instructions](#)
3. [Fisher CS400 Series Regulator Bulletin](#), January, 2020
4. [Fisher CS800 Series Regulator Bulletin](#), July, 2019
5. [Fisher 289H Relief Valve, Oct 2014](#)
6. [Fisher 299 Regulator Bulletin](#), September, 2020
7. [Gas Auxiliary Equipment](#)
8. [Grunsky Gas Meter Quick Change Equipment](#)
9. [Grunsky Portable CNG Tank and Bag Procedures](#)
10. [Itron B31 Series Regulator](#), September, 2018
11. [Itron B34 Series Regulator](#), August, 2018
12. [Itron B42 Series Regulator](#), September, 2018
13. [Itron CL31 Series Commercial Regulator](#), September, 2018
14. [Itron CL34 Series Regulator](#), September, 2018
15. [Meter Guards, 2-inch Posts - Updated](#)
16. [Meter Guards, 4-inch Posts - Updated](#)
17. [BelGas P100SX Operating Manual](#)
18. [PF FE 25 Operating Manual](#)

End of Section.

UNCONTROLLED IF PRINTED

Document Rescission

METR 4 Forms and Reference Materials, December 15, 2021

Revision Notes

Location of Changes	Summary of Changes
Forms	<p>Updated:</p> <p>Electronic Corrector Inspection Form – Fillable (April 27, 2022)</p> <p>Electronic Corrector Verification Form – Fillable (April 27, 2022)</p> <p>New:</p> <p>Ultrasonic Meter Inspection Form - Daniel Meter</p> <p>Ultrasonic Meter Inspection Form - Instromet Meter</p> <p>Ultrasonic Meter Inspection Form - Sick Meter</p>
Appendix A – Ultrasonic Meter	Transmitter Inspection interval changed to 6 months rather than 3 months

Appendix A - Meter Test Schedules & Retention Requirements

Equipment or Action	Test Requirement	Schedule Requirement	Tolerance or Comments	File Location	Record Retention
Sample Testing (Ref METR 2.2, Sect. 4.0)	Sample "Lot" in 9th service year & every year thereafter	Complete test annually by 12/31	± 3%	MMS	For meter life
<ul style="list-style-type: none"> Requires Plan be filed annually with Form 21 report. Distribute 1st round list in Dec.; Exchange meters by 5/31. Rejected Lots to be 100% removed w/in 24 months after current year sampling. 					
Periodic Testing (Ref METR 2.2, Sect. 5.0) (Meters not included in sample testing program)	• Diaphragm meters ≥ 800 cfh	10-yr interval		MMS (or paper)	For meter life
	• Rotary meters	• Field differential or shop accuracy every 60 months	• Max 50% higher than initial • Clean/retest w/in 7 days • Replace w/in 60 days	MMS (or paper)	For meter life
		For meters impacting structure, see METR 2.4, 5.7.3.			
		Conditions delay test, then do ASAP or by 4 months, whichever is shorter. (See METR 2.4, 5.3.3)		MMS (or paper)	3 yrs - Qualify delay regarding 60-month test
	• Turbine meter	Accuracy test every 60 months	Press. range w/in 50% to 2X operating pressure	MMS (or paper)	For meter life
• Dual-rotor turbine meter	• Accuracy test every 120 mo. if ext. lube • A means to verify accuracy every 6 mo. • Spin test (lubricate?) every 12			MMS (or paper)	For meter life

UNCONTROLLED IF PRINTED

		months • Spin test every 6 mo. if no ext. lube fittings			
	• Ultrasonic meter • Related transmitters	• Interrogate every 3 months • Flow calibrate every 120 months (See METR 2.4, 8.2.8)	Test as pkg w/ other components	MMS (or paper)	5 or 10 Years (See 11.5)
		Verify/calib. every 6 mo.		MMS (or paper)	5 years
Prover Certification (Ref METR 2.3, Sect. 5.0)	• All provers	Calibrate & certify every 36 months		MMS	At least 3 years
	• Sonic-nozzle provers	Calibrate & certify every 12 months		MMS	At least 3 years
	• Meter shop reference meters	Verification test every 3 months	Use AL800 reference meter	MMS	At least 3 years
	• Meter shop sonic-nozzle prover	Verification test weekly	Use non-temp. comp. ref. meter: • American AC250 for ≥275 cfm meters • American AL425 for > 275 cfm meters	MMS	At least 3 years
Gas Metering Supervisor (ea. Shop) to review reference meter logs weekly.			• Typ. ± 0.5% • Spread max 1% • Room temp change max 4°F	Weekly Gas Ref. Meter Results Report	At least 3 years
Transfer Prover (Ref METR 2.3, Sect.7.0) (For meters ≥ 630 cfm rating)			• Check between 20%-33%; typ. 30% • Open flow @ 100% • Ensure >30 sec	MMS	At least 3 years
	Adjust-Tested (Following repair)		• Diaphragm meters w/in 0.5% • Rotary meters w/in 0.75% • Max 1% spread between check-flow & open-flow	MMS	At least 3 years
	AMR Verification		Ensure correctly programmed	MMS	At least 3 years
Rotary Meter Diff. Test (Ref METR 2.4, Sect. 5.0)	Initial test	W/in 6 months after "In-Service" date	Conduct @ 10% capacity	MMS*	For meter life
	Periodic test	• Every 60 months • If conditions delay test, then do AS-AP or by 4 months, whichever is shorter. (See METR 2.4, 5.3.3)	• Conduct @ 10% capacity • Max 50% increase • Do maint. & retest w/in 7 days	MMS* (Historical records may be paper copy)	For meter life
• Alternate test can be accuracy test. • If meter cannot be corrected, must replace w/in 60 days.					
Turbine Meter (Ref METR 2.4, Sect.6.0)	Spin test	• Every 12 months (if ext. lube fittings) • Every 6 mo. (if no ext. lube fit-	Spin 3 times & average (See METR 2.4 Tables 1 & 2 for min. spin times)	MMS	For meter life

UNCONTROLLED IF PRINTED

		tings) • Not req'd for dual-rotor turbine; Verify cond. @ 6 mo.	(See METR 2.4, 6.2.1, 3)		
	Accuracy test	<ul style="list-style-type: none"> • Every 60 months • Test w/in 50% to 200% of meter operating. pressure 	<ul style="list-style-type: none"> • Use 4 flow rates when atm. testing • Run between 10% & 105% of rated capacity • Do 5 flow rates at opr. pressure • Req'd w/in 1% 	MMS	For meter life
	Accuracy test for dual-rotor turbine	<ul style="list-style-type: none"> • Every 120 months • Verify @ 6 months 	(See METR 2.4, 6.2.2, 2)	MMS	For meter life
Ultrasonic Meter (Ref METR 2.4, Sect.7.0)	Multi-path ultrasonic	Verify condition every 3 months	<ul style="list-style-type: none"> • 2 of 4 yearly reports must be w/gas flowing • Min. 2 minutes of data 	USM Share-Point (or paper)	5 years
		Flow calibrate every 120 months		USM Share-Point (or paper)	Accuracy test: 10 years
	Transmitter inspection	Every 6 months		Save electronic copies	Send to Decatur Meter Shop
	Gas Chromatograph operational check	<ul style="list-style-type: none"> • Every 3 months • Recertify/ replace ref cylinder every 36 months 	W/in ± 1.5%	USM Share-Point (or paper)	Equipment life PLUS 3 years
New Meters (Ref METR 2.3, Sect.8.0)	Level II with an AQL of 1.0%	Randomly sample all	<ul style="list-style-type: none"> • W/in 0.75% • Max spread 1% 	MMS (or paper)	For meter life
Customer Requested Test (Ref METR 2.2, Sect.6.0)		Complete test w/in 45 days (See METR 2.2, Sect. 6.0 for Referee test)		MMS	Results to customer w/in 5 business days
Meter Header Inspection (Ref METR 2.2, Sect.7.0)			See METR 2.2, Sect. 7.0 for requirements	ClickMobile Report to Gas Supervisor	At least 3 years

ODOR-Odorization

ODORIZATION

April 1, 2021

ODOR 0 Table of Contents

ODOR 1 Odorization: Requirements

Section 1.0 Purpose
Section 2.0 Scope
Section 3.0 Target Audience
Section 4.0 General
Section 5.0 Odorant Properties and Types
Section 6.0 Odorant Concentration
Section 7.0 Monthly Odorization Report
Operator Qualification
Compliance Requirements
Reference Documents
Document Rescission

ODOR 2.1 Odorization: Odorant Intensity Sampling and Testing

Section 1.0 Purpose
Section 2.0 Scope
Section 3.0 Target Audience
Section 4.0 General
Section 5.0 Employee Threshold Testing
Section 6.0 Intensity Test Instruments
Section 7.0 Odorant Intensity Test Sites and Schedule
Section 8.0 Odorant Intensity Testing
Section 9.0 Sniff Tests
Section 10.0 Records
Operator Qualification
Appendices
 Appendix A - Odorant Intensity Testing Work Flow
Compliance Requirements
Reference Documents

UNCONTROLLED IF PRINTED

Document Rescission

ODOR 2.2 Odorization: Odorant Operations and Transportation

Section 1.0 Purpose

Section 2.0 Scope

Section 3.0 Target Audience

Section 4.0 Odorization Location

Section 5.0 Odorization Equipment

Section 6.0 Odorization Operation and Inspection

Section 7.0 Liquid Odorant Tank to Tank Transfer

Section 8.0 Records

Operator Qualification

Compliance Requirements

Reference Documents

Document Rescission

ODOR 2.3 Odorization: Emergency Response

Section 1.0 Purpose

Section 2.0 Scope

Section 3.0 Target Audience

Section 4.0 General

Section 5.0 Emergency Response Actions

Section 6.0 Odorization Emergency Situations

Operator Qualification

Appendices

Appendix A - Odorant Event Report

Compliance Requirements

Reference Documents

Document Rescission

ODOR 3 Odorization: Forms and Reference Materials

Forms

References

Document Rescission

End Table of Contents.

Document Rescission

UNCONTROLLED IF PRINTED

ODOR 0 Odorization: Table of Contents, October 1, 2020.

Revision Notes

Location of Changes	Summary of Changes
ODOR 1	Removed Appendix A – Monthly Odorization Report

ODORIZATION

April 1, 2023

ODOR 1 Requirements

1.0 Purpose

This document describes specifications for odorant properties and required odorant concentration levels in natural gas transported by Ameren Illinois (AIC).

Odorization of natural gas must meet the minimum requirements of 49 CFR §192.625.

2.0 Scope

This document addresses the following:

[3.0 Target Audience](#)[4.0 General](#)[5.0 Odorant Properties and Types](#)[6.0 Odorant Concentration](#)[7.0 Monthly Odorization Report](#)**3.0 Target Audience**

- Gas Tech Engineering (GTE)
- Gas Tech Services (GTS) Supervisors
- Gas Tech Services (GTS) Personnel
- Gas Storage Engineering (GTS)
- Gas Storage Field Supervisors
- Gas Storage Field Operators
- Gas Field Personnel
- Gas Supervisors
- Gas Control

4.0 General

- 4.1 The primary method for ensuring the safety of the general public and AIC natural gas customers is by introducing the proper amount of odorant into the natural gas transported through AIC gas system. Odorant is introduced into the natural gas provided by AIC pipeline suppliers.
- 4.2 Annually, AIC distributes information to all of their customers explaining why odorant is added to natural gas and how customers should respond if they detect a "rotten egg" smell in or around their home or place of business.



5.0 Odorant Properties and Types

- 5.1 AIC uses a Mercaptan blend which sufficiently odorizes natural gas when added in the proper quantity. The following odorant blends are currently allowed:
- 5.1.1 **80% Tertiary Butyl Mercaptan (TBM) and 20% Methyl Ethyl Sulfide (MES):**
Commonly called S-20.
- 5.1.2 **15% Secondary Butyl Mercaptan (S-Butyl) and 85% Hexane (n-Hexane):**
Commonly called H-85.

H-85 shall only be used in controlled circumstances.
Never use H-85 as a substitute for S-20.

5.2 The odorant blend must meet the following requirements (Table 1):

Table 1: Odorant Requirements

	
It shall have an unpleasant, distinctive odor that is readily identifiable with natural gas ("rotten egg") and is different from other odors in the area.	It must not be harmful to persons, materials, or piping exposed to it in normal concentrations.
It must be capable of maintaining a relatively constant odor level.	It must not lose more than 2.5% of its weight in water.
In normal concentrations, it must be completely combustible in a gas flame.	It must not produce any toxic or corrosive products.

6.0 Odorant Concentration

6.1 Odorant is introduced into the gas system at a rate such that a person with a normal sense of smell can readily detect it in concentrations of 20% (1/5th) of the lower explosive limit (LEL), or approximately 1% gas in air. Ameren's average target odorization introduction rate is:

6.1.1 **S-20 (80/20) blends:** One pound of odorant per million standard cubic feet of corrected gas volume (1 Lb/MMSCF).

6.1.2 **H-85 (15/85) blends:** Four pounds of odorant per million standard cubic feet of corrected gas volume (4 Lb/MMSCF).



6.2 Table 2 shows the target range of acceptable odorant concentration levels for S-20 (80/20) and H-85 (15/85) odorant blends.

6.3 Odorizer type and target injection rates can vary depending on station size, flow rates, and system design. Adjust the odorizer if necessary:

6.3.1 To maintain odorant concentration at recommended levels.

6.3.2 To optimize or supplement odorant concentration at storage fields, during pipeline conditioning (pickling) procedures, and at locations where supply sources do not provide adequate odor intensity.

Table 2: Odorant Concentration Levels

Odorant Blend	Odorant Concentration Levels - Target Range (Pounds of odorant per million standard cubic feet of gas)				
	Out of range 	Target range 			Out of range 
		Minimum	Recommended	Maximum	
S-20	Less than 0.50	0.50	1.0	1.5	Greater than 1.5
H-85	Less than 3.0	3.0	4.0	6.0	Greater than 6.0

UNCONTROLLED IF PRINTED

Response	If intensity test reading is out of range, then verbally notify GTS Supervisor. Take corrective action immediately.	No action required	If intensity test reading is out of range, then verbally notify GTS Supervisor. Take corrective action immediately.
	If calculated usage is out of range, then Maximo will generate an Odorant Injection Rate Investigation. Take corrective action immediately.		If calculated usage is out of range, then Maximo will generate an Odorant Injection Rate Investigation. Take corrective action immediately.

7.0 Monthly Odorization Report

Farm tap odorizers are exempt from monthly checks.

- 7.1 Use the Monthly Odorization Report as a worksheet to calculate the following values each month. See **ODOR 3**.
 - 7.1.1 Odorant usage
 - 7.1.2 Rate of odorization, AND/OR
 - 7.1.3 Odorant reserve (amount of odorant in storage).
- 7.2 Determine odorant injection/usage rate and amount of odorant in storage each month.
 - 7.2.1 Calculate the average odorant usage by measuring the volume of liquid odorant consumed during a specified period of time (normally monthly) and dividing that number by the measured corrected volume of gas during the same period, and enter monthly usage in Maximo.

$$\text{Average Odorant Usage} = \frac{\text{Actual Volume of Odorant Consumed for a specific period [Lbs]}}{\text{Corrected Volume of Gas Delivered for a specific period [MMSCF]}}$$

- 1. If calculated usage is out of range, then Maximo will generate an Odorant Injection Rate Investigation.
 - 1 a. *S-20 (80/20) blends*: Calculated usage is out of range if less than 0.50 OR greater than 1.5 Lbs/MMSCF.
 - 1 b. *H-85 (15/85) blends*: Calculated usage is out of range if less than 3.0 OR greater than 6.0 Lbs/MMSCF.
- 7.2.2 If the warning message is displayed, then:
 - 1. Verbally notify GTS Supervisor or Gas Storage Supervisor.
 - 2. Take corrective action immediately to reestablish odorization rate at target level. Corrective actions may include:
 - 2 a. Increasing, decreasing, stopping or performing "valve-off" of odorizer
 - 2 b. Flaring
 - 2 c. Gas system purging
 - 2 d. Site mitigation
 - 2 e. Verification:

- (i) Performing odorant intensity tests with approved equipment
- (ii) Increasing odorizer operational inspection frequency
- (iii) Other actions as specified by GTS Management

7.3 GTS Supervisor shall conduct an annual review of the average odorant injection rates, by-pass rates, and actual quantities of odorant consumed at each odorizer installation. This review ensures adequate odorization and provides documentation that each odorizer site is configured, adjusted and operating properly and has provided the prescribed odorant-to-gas ratio specific to that site.

7.3.1 Calculate the annual odorant usage rate for each odorizer (odorant absorbed or injected):

$$\text{Average Odorant Usage} = \frac{\text{Actual Volume of Odorant Consumed for a specific period [Lbs]}}{\text{Corrected Volume of Gas Delivered for a specific period [MMSCF]}}$$

End of Instructions.

Operator Qualification (OQ) Required?

YES

1211: Odorization - Periodic Sampling

1221: Odorization - Odorizer Inspection, Testing, Preventive and Corrective Maintenance

1371: Operate Gas Pipeline – System Control Center Operations

Appendices

NONE

Attachments

NONE.

Compliance Requirements

49 CFR §192.625 Odorization of gas.

Reference Documents

NONE.

Document Rescission

ODOR 1 Odorization: Requirements, October 1, 2021.

Revision Notes

Location of Changes	Summary of Changes
Paragraph 6.3.2 Table 2 – Odorant Concentration Levels	Target Range – Maximum for S-20 – Changed to 1.5 from 1.25. Out of Range – S-20 – Changed to Greater than 1.5.
Paragraph 7.2.1 Item 1a.	S-20 – Out of Range if greater than 1.5 Lbs/MMSCF

ODORIZATION

April 1, 2023

ODOR 2.1 Odorant Intensity Sampling and Testing

1.0 Purpose

This document describes the requirements for odorant intensity sampling and testing.

The odorization of gas services must meet the minimum requirements of 49 CFR §192.625.

2.0 Scope

This document addresses the following:

[3.0 Target Audience](#)[4.0 General](#)[5.0 Employee Threshold Testing](#)[6.0 Intensity Test Instruments](#)[7.0 Odorant Intensity Test Sites and Schedule](#)[8.0 Odorant Intensity Testing](#)[9.0 Sniff Tests](#)[10.0 Records](#)

Appendices

[Appendix A - Odorant Intensity Testing Work Flow](#)**3.0 Target Audience**

- Gas Engineering
- Gas Tech Engineering (GTE)
- Gas Field Personnel
- Gas Supervisors
- Gas Tech Service (GTS) Supervisors
- Gas Tech Service (GTS) Personnel

4.0 General

- 4.1 To ensure proper odorization (concentration of odorant), Ameren Illinois (AIC) requires periodic sampling and testing of the natural gas transported within its system. Qualified gas field personnel perform odorant intensity tests and sniff tests.
- 4.1.1 *Odorant intensity tests:* Odorant intensity tests are performed monthly at selected sampling sites, using an approved instrument. The instrument must be capable of determining the percentage of gas in air at which the odor becomes readily detectable to a person with a normal sense of smell. See [Section 8.0](#) Odorant Intensity Testing.
- 4.1.2 *Sniff tests:* Sniff tests are performed in the course of routine gas field work by personnel using their nose. Sniff tests supplement the monthly odorant intensity tests. See [Section 9.0](#) Sniff Tests.
- 4.2 Gas field personnel who perform the odorant intensity tests and sniff tests must be periodically examined to verify that they have a normal sense of smell.

UNCONTROLLED IF PRINTED

4.2.1 A person's normal sense of smell can be affected by smoking, eating spicy foods, chewing tobacco or gum, or the presence of other strong odors. Health-related conditions (e.g., head cold, allergies) can also affect sense of smell.

4.2.2 Avoid prolonged or repetitive exposure to natural gas because the odorant will cause olfactory fatigue.

4.2.3 See [Section 5.0](#) Employee Threshold Testing.

4.3 Gas field personnel must have working knowledge of the odorant sampling instruments and understand manufacturer operating instructions.

5.0 Employee Threshold Testing

5.1 Threshold testing gives a comparative indication of an operator's ability to recognize odorant on any given day.

5.2 Before performing odorant intensity testing, the operator's threshold level should be tested by another employee.

5.2.1 Have the operator and attending employee obtain a threshold detection level on an odorized gas source, typically at the employee's work location.

5.2.2 Report the threshold test in the ClickMobile Comment section for the first intensity test performed for the day.

6.0 Intensity Test Instruments

Always operate odorant intensity instruments in accordance with manufacturer instructions.

6.1 Odorant test instruments use the principle of combining a gas and air sample mixture in a chamber where an operator then uses their nose to rate the odor intensity of the sample.

6.2 AIC uses **2 approved portable air dilution instruments to determine odor intensity:**

6.2.1 Health Odorator 2.

6.2.2 YZ-DTEX Odorant Detection System.

6.3 Perform calibration once each calendar year, not to exceed 12 months. Record results in Maximo.

7.0 Odorant Intensity Test Sites and Schedule

Choosing the proper test point locations is critical to the success of the odorization process.

7.1 Tasks and Responsibilities

7.1.1 *Schedule and locations:* (GTS Supervisor, GTS Engineer OR Gas Engineer) shall establish odorant intensity test schedule and determine test sites. At a minimum, sites will be sampled once per calendar month.

- 7.1.2 *Survey plan:* (Gas Supervisor OR Gas Engineer) shall establish a survey plan which lists pre-determined test sites. Pre-determined test sites will have Test Point IDs established in Maximo for each odorized system.
- 7.1.3 *Annual review:* Sample sites should be reviewed by (GTS Supervisor, GTS Engineer OR Gas Engineer) AND by Operations as part of the annual System Review.

7.2 Test Site Selection

Test points should **not** be established at regulator stations, where soft components (e.g. gaskets and boots) can absorb concentrated gas smells, deceiving or creating a bias in test results.



- 7.2.1 Choose survey test points throughout the system, to test odor levels under a variety of conditions and to provide a baseline for future troubleshooting.
- 7.2.2 The number of sites selected will depend on the size and configuration of the odorized system, location of the delivery points, and locations at end of mains. Consider plotting test points on system maps to allow review as areas of growth or change occur.
- 7.2.3 Consider the following when selecting test point locations:
 - 1. *Endpoints of the system:* If odorant is adequate at the ends of the system, then it is reasonable to assume that there is adequate odorization at all points in between.
 - 2. *Areas of low or changing flow rates, anticipated gas flows in summer and winter months:* Small loads on long, dead-end pipeline systems are more likely to experience odorant fade than large metropolitan areas with considerable gas usage.
 - 3. *Known problem areas, areas known to cause odorant masking or fade:* Typical causes include:
 - 3 a. High liquid levels within the pipeline
 - 3 b. Dust, rust, dry contaminants, or pipeline debris
 - 3 c. Gas processing equipment (especially desulfurization equipment)
 - 4. *New construction:* At the end of recently installed long gas main extension, steel or plastic.
 - 5. *Random locations:* Metering locations with pre-existing quick connect couplings such as at schools, or other public facilities may be chosen depending on their location in the system.

8.0 Odorant Intensity Testing

Abnormal (out-of-range) odorant intensity readings must be immediately verbally reported to the Supervisor so that corrective action can be taken.

- 8.1 Perform odorant intensity testing once each calendar month at sampling sites identified by the Gas Supervisor and designated in Maximo.
- 8.2 Both a Threshold and Readily Detectable Level are required during the monthly odorant intensity test point readings. Gradually increase the gas content of the sample to obtain a Threshold Detection Level (TDL) first and then a Readily Detectable Level (RDL) next.
 - 8.2.1 *Threshold Detection Level*: Percent gas in air reading where the concentration of odorant in the mixture is identified as barely detectable.
 - 8.2.2 *Readily Detectable Level (Olfactory Level)*: Percent gas in air reading where the concentration of odorant in the mixture is identified as readily detectable.
- 8.3 Odorant Intensity Readings
 - 8.3.1 Acceptable odorant intensity readings (Readily Detectable Levels) are from 0.1% up to and including 0.8% gas in air. See Table 1 below.

Table 1 Odorant Intensity

	Odorant Intensity - Readily Detectable Level (RDL)		
	Too Strong 	Acceptable 	Too Weak 
Reading	Less than 0.1% gas in air	0.1% - 0.8% gas in air	More than 0.8% gas in air
Response	Immediately notify GTS Supervisor verbally	No action needed	Immediately notify GTS Supervisor verbally

8.3.2 If the reading is less than 0.1% OR more than 0.8%, then:

1. Immediately notify GTS Supervisor verbally so that required corrective action can be taken.
2. Document corrective actions in ClickMobile and Maximo.
3. Repeat the intensity testing daily (including weekends and holidays) until reading is within the acceptable range.

- 8.4 During the test, pause frequently to breathe fresh air to avoid olfactory fatigue, which desensitizes the sense of smell. Allow a minimum of 15 minutes between odorant intensity and readings.
- 8.5 When a customer is available during the odorant intensity test, ask the customer if they would like to participate in Threshold and Readily Detectable tests. Document the results of the customer's odorant intensity testing.

9.0 Sniff Tests

Daily work on customer premises provides frequent opportunities to ensure that gas odor is readily detectable.

- 9.1 Sniff tests supplement the monthly odorant intensity tests. See [GLOS](#) for definition of sniff test.
- 9.2 Gas field personnel should use their nose to sniff the gas when performing leak investigation work on customer premises. See [LEAK 2.3](#) Leak Investigation Form.

UNCONTROLLED IF PRINTED

9.3 If gas field personnel suspect over-odorized (strong smelling) OR under-odorized (weak smelling) gas that is not readily detectable, then:

9.3.1 Personnel shall immediately verbally contact their Supervisor or other AIC management personnel.

9.3.2 Gas Supervisor will immediately schedule odorant intensity checks in the suspected area to determine the actual intensity value.

9.3.3 All odorization events should be referred to GTS Supervisor or GTS Technician.

10.0 Records

10.1 Odorant Intensity Test records shall be retained in Maximo for a minimum of 5 years.

End of Instructions.

Operator Qualification (OQ) Required?

YES

1211: Odorization - Periodic Sampling

1221: Odorization - Odorizer Inspection, Testing, Preventive and Corrective Maintenance

Appendices

[Appendix A - Odorant Intensity Testing Work Flow](#)

Attachments

NONE.

Compliance Requirements

49 CFR §192.625 Odorization of gas.

Reference Documents

[GLOS Glossary](#)

[LEAK 2.3 Leak Management: Leak Investigation Form](#)

Heath Odorator 2 Operator's Manual available online [here](#).

[YZ-DTEX DX1000G/L Instruction & Operating Manual \(See **ODOR 3**\)](#)

Document Rescission

ODOR 2.1 Odorant Intensity Sampling and Testing, May 15, 2022

Revision Notes

Location of Changes	Summary of Changes
Subsection 6.2	Added the YZ-DTEX instrument as approved for determining odor intensity.

Appendix A - Odorant Intensity Testing Work Flow

A-1. The flowchart below provides a quick reference for the work flow based on the results of the monthly odorant intensity testing.

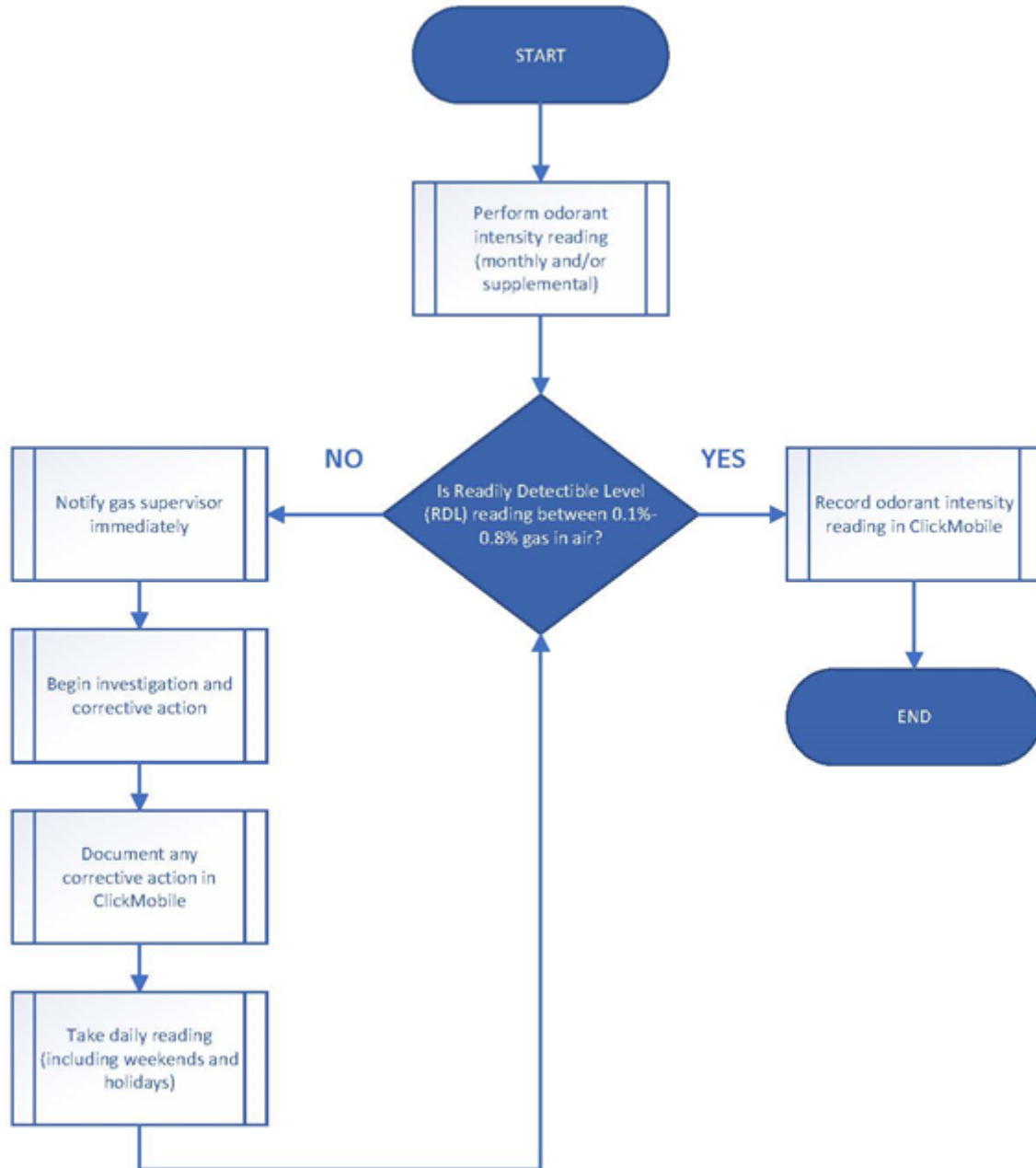

ODORIZATION

October 1, 2022

ODOR 2.2 Odorization Operations and Transportation

1.0 Purpose

This document addresses odorizer location, equipment, operations and inspection along with odorant transfer and transport.

The odorization of gas services must meet the minimum requirements of 49 CFR §192.625.

The transportation of liquid odorant must meet the minimum requirements of 49 CFR Part 172: Subpart D - Marking, Subpart E - Labeling, and Subpart F - Placarding.

2.0 Scope

This document addresses the following:

[3.0 Target Audience](#)

[4.0 Odorization Location](#)

[5.0 Odorization Equipment](#)

[6.0 Odorization Operation and Inspection](#)

[7.0 Liquid Odorant Tank to Tank Transfer](#)

[8.0 Records](#)

3.0 Target Audience

- Gas Tech Services (GTS) Supervisors
- Gas Tech Services (GTS) Personnel
- Gas Storage Field Supervisors
- Gas Storage Field Operators
- Gas Control Personnel

4.0 Odorization Location

- 4.1 Odorizer equipment is typically installed at the point of supplier delivery and the point of withdrawal from a storage field.
- 4.2 Where individual customers are served by an unodorized line, odorization equipment shall be installed.
- 4.3 Odorization equipment is located to ensure that all gas supplied by the Ameren Illinois' (AIC) gas system is adequately odorized so that it is readily detectable by an individual with normal sense of smell.

5.0 Odorization Equipment

- 5.1 Approved types of odorizer equipment include wick, bypass, drip or positive injection.
- 5.2 Odorizers and associated piping must be carefully designed and installed to avoid liquid or vapor leakage.
- 5.3 Odorizer equipment must introduce odorant into the gas stream without wide variations in the level of odorant.

6.0 Odorization Operation and Inspection

UNCONTROLLED IF PRINTED

- 6.1 Adequate odorization requires careful monitoring of the odorizers, odorization rates, odorant consumption, odorant levels, and odorant intensity. See [ODOR 1](#) Requirements.
- 6.2 Remote monitoring of odorization
 - 6.2.1 Odorization equipment may be equipped with remote monitoring of injection rates and usage.
 - 6.2.2 Where applicable, Gas Control will monitor odorizer operations that have remote monitoring capability.
- 6.3 Response to abnormal operating conditions in odorization operations
 - 6.3.1 When Gas Control is remotely monitoring, then:
 - 1. Gas Control will verbally contact the appropriate Gas Technical Services (GTS) OR Gas Storage Supervisor for instructions, OR dispatch a GTS technician or Gas Storage Operator to investigate.
 - 2. GTS technicians OR Gas Storage Operator should contact Gas Control upon arrival at the odorization station.
 - 3. After completing the investigation and/or repair, verbally notify Gas Control of the investigation results and subsequent follow-up action.
 - 4. GTS Technician OR Gas Storage Operator will perform an investigation and document the following:
 - 4 a. As found conditions
 - 4 b. Immediate corrective actions
 - 4 c. As left conditions
 - 4 d. If follow-up action is required.
 - 5. Gas Control will complete and close-out their alarm management documentation.
 - 6.3.2 Un-telemetered odorizers and odor-related issues:
 - 1. GTS Technician OR Gas Storage Operator will perform an investigation and document the following:
 - 1 a. As found conditions
 - 1 b. Immediate corrective actions
 - 1 c. As left conditions
 - 1 d. If follow-up action is required.
- 6.4 Inspections
 - 6.4.1 In-service odorizers
 - 1. Inspect all in-service odorizers at least monthly and enter into ClickMobile. More frequent inspections may be necessary depending on the type of odorizer, means of monitoring odorant storage level, characteristics of gas demand and time of year (e.g., grain drying season).
 - 2. Check the piping connected to the odorizer odorant leaks and atmospheric corrosion and document on the Odorizer Inspection Form in ClickMobile.
 - 6.4.2 Farm tap odorizers

UNCONTROLLED IF PRINTED

1. Inspect annually for condition, operation, usage and refill when required.
2. Perform an annual intensity test to verify gas is odorized.

7.0 Liquid Odorant Tank to Tank Transfer

Natural gas odorant, mercaptan, is a Class 3 flammable liquid designated hazardous by PHMSA Hazardous Material Regulation Guide (HMRG).

7.1 General

- 7.1.1 **Safety is our top priority.** Always follow safe practices when handling, storing, transporting, or disposing of odorant.
- 7.1.2 Mercaptan liquid is lighter than water. Mercaptan vapor is heavier than air.

7.2 Personal Safety and PPE

- 7.2.1 Individuals shall be qualified through appropriate training and experience in handling liquid odorant.
- 7.2.2 Individuals shall be familiar with the location of tank valves and shut-offs before beginning transfer.
- 7.2.3 Use the weather to your advantage. Avoid low atmospheric pressures and unfavorable winds when working with odorant.
- 7.2.4 Ensure that the proper class of fire extinguisher, minimum rating 20-B/C, is on site during the transfer.
- 7.2.5 Wear non-permeable gloves and eye goggles when working on or near pressurized odorant lines. Consider also wearing respirators with organic cartridges and non-static clothing.
- 7.2.6 Have an eye wash solution readily available.

7.3 Preparing to Transport

- 7.3.1 Delivery vehicle is the tank or container of odorant that is brought to the odorizer site for transfer to the odorant storage tank.
- 7.3.2 HAZMAT endorsement (x) is required on CDL to transport hazardous materials in bulk.
 1. Bulk odorant loads of 1001 pounds OR 119 gallons (OR more) must be placarded with identification number 3336 (Mercaptans, Liquid, Flammable) and a hazard class 3 (Flammable Liquid). See Figure 1.
 2. Placard shall be displayed on all four sides of the truck or trailer and be readily visible and unobscured.
 3. Placards must remain displayed on bulk odorant delivery, even when empty.



Figure 1: DOT HAZMAT Placard for bulk odorant loads

7.3.3 Shipping papers are required with hazmat loads that exceed the Material of Trade Exception for a Class 3, Packing Group 1/2/3 material.

7.3.4 Ameren Shipping Paper for Odorant must be properly completed and remain within reach of the driver during transport. Contact GTS for more information. Shipping papers are always required, whether the tanks are empty or full. See [ODOR 3](#) for a template of the Ameren Shipping Paper.

7.4 Transferring Liquid Odorant from Delivery Vehicle to Odorant Storage Tank

7.4.1 General

1. Use closed-loop odorant transfer methods whenever possible.
2. Avoid open pouring or siphoning of liquid odorant **except** when filling wick odorizer(s).

7.4.2 Before beginning transfer

1. Bonding wire between delivery vehicle and odorant storage tank

Failure to maintain the bonding connection creates the risk that static charge can become a source of ignition.

- 1 a. **Always** bond the delivery vehicle and the odorant storage tank by connecting them with a bonding wire. The connection shall be maintained through the entire transfer process to eliminate risk of static charge being a source of ignition.

2. Hoses and fittings

Recommended replacement hoses for liquid odorants are SAE 100R7 or SAE 100R8 hoses with thermoplastic core, polyurethane cover and convoluted stainless steel with braided wrap.

- 2 a. Verify that hoses are compatible with liquid odorant and have the correct pressure rating.
- 2 b. Hoses should be pressure tested annually.
- 2 c. Check hoses and fittings for cracks and damage. If damage is found, then dispose of hoses and fittings properly.

7.4.3 Performing the transfer

UNCONTROLLED IF PRINTED

1. To create adequate differential to move odorant into the storage tank, the delivery vehicle pressure should be 10 to 20 psig greater than the storage tank pressure.
 - 1 a. Delivery vehicle typical pressure is 0-40 psig. **Do not** exceed 40 psig maximum.
 - 1 b. **Do not** fill storage tank to more than 80% of its known volume to allow for thermal expansion of the liquid.
 - 1 c. Pressure in the storage tank may need to be lowered to facilitate a safe transfer of odorant. Storage tank does not need to be blown-down completely, but only low enough to allow for transfer.
 - (i) **Do not** blow down any odorant vessel to the atmosphere.
 - (ii) Use flaring of vapor from the storage tank to avoid migrating gas odors and subsequent complaints from the general public. Before flaring, check environment, wind speed and direction, and the surrounding area for potentially combustible materials.
2. Commercial odorant delivery may use compression or vacuum to transfer the odorant between the storage tank and delivery vehicle.
3. Use a pressure regulated standing pilot flame at the flare to ensure ignition and complete incineration of the odorant vapor and possible hydrocarbons.
4. Use tank-top connections whenever possible. **Do not use** tank-bottom valves or connectors.
5. Use blow-back connections to clear lines of suspended liquid odorant prior to disconnecting and depressurizing.

7.4.4 After completing the transfer

1. Clean all tools and fittings with deodorizing agent to mitigate odors in transit.
2. Avoid public areas. Clothing will likely become permeated and contaminated with odorant, but personnel may not be able to detect odor due to olfactory fatigue.

8.0 Records

- 8.1 Monthly inspections and odorization rates shall be maintained in Maximo for a minimum period of 5 years. Paper documents may be used as supplemental information.
- 8.2 Gas Control maintains electronic SCADA records of monitored odorizer operations.
- 8.3 Ameren Shipping Paper for Odorant transportation has a retention period of 2 years and copies must be filed locally at the OC or saved electronically to a known and discoverable drive.

End of Instructions.

Operator Qualification (OQ) Required?

YES

1211: Odorization - Periodic Sampling

UNCONTROLLED IF PRINTED

1221: Odorization - Odorizer Inspection, Testing, Preventive and Corrective Maintenance

1371: Operate Gas Pipeline – System Control Center Operations

Appendices

NONE

Attachments

NONE.

Compliance Requirements

49 CFR Part 172 Hazardous Materials Table, Special Provisions, Hazardous Materials Communications, Emergency Response Information, Training Requirements, and Security Plans: Subpart D - Marking, Subpart E - Labeling, Subpart F - Placarding.

49 CFR §192.625 Odorization of gas.

Reference Documents

NONE.

Document Rescission

ODOR 2.2 Odorization: Odorization Operation, April 1, 2021.

Revision Notes

Location of Changes	Summary of Changes
Appendix A	Deleted

ODORIZATION

October 1, 2021

ODOR 2.3 Emergency Response

1.0 Purpose

This document addresses emergency response guidelines related to liquid odorant spills, vaporized odorant releases, and low/high odorant intensity situations.

2.0 Scope

This document addresses the following:

[3.0 Target Audience](#)[4.0 General](#)[5.0 Emergency Response Actions](#)[6.0 Odorization Emergency Situations](#)

Appendices

[Appendix A - Odorant Event Report](#)**3.0 Target Audience**

- Gas Engineering
- Gas Field Personnel
- Gas Supervisors
- Gas Tech Services (GTS) Supervisors
- Gas Tech Services (GTS) Personnel
- Gas Storage Field Supervisors
- Gas Storage Field Operators

4.0 General

- 4.1 Individuals handling odorant shall be trained in accordance with 49 CFR §172.704.
- 4.2 Odorant spill kits are readily available at strategic gate stations located throughout Ameren Illinois operating centers.

5.0 Emergency Response Actions

- 5.1 Emergency response requires immediate, continuous action.
- 5.1.1 Verbally contact:
1. GTS OR Gas Storage Supervisor,
 2. Dispatch, AND
 3. Local AIC Region support.
- 5.1.2 GTS OR Gas Storage Supervisor shall notify Gas Compliance of the emergency event.
- 5.1.3 GTS OR Gas Storage Supervisor should contact Gas Leadership and Team CPR as needed.
- 5.1.4 Initiate and complete the Odorant Event Report. See [Appendix A](#).

6.0 Odorization Emergency Situations

UNCONTROLLED IF PRINTED

6.1 Uncontrolled Release of Odorant (Liquid odorant spills and vaporized odorant releases)

Liquid and vaporized odorant are extremely flammable.

6.1.1 Take the following safety precautions:

1. Establish a Safe Zone around odorant release. Consider the wind direction, weather conditions, and impact on population.
2. Remove/de-energize ignition sources.
3. Use appropriate PPE. A minimum of Level 1 PPE is required when there is pooling, standing, or an uncontrolled release of odorant liquid or vapor. (See [WIGE 2.2](#) Personal Protective Equipment for Level 1 PPE.)

6.1.2 Stop and contain the release

1. Deploy spill kit contents.
2. Cover any liquid odorant release. Use dirt or plastic.
3. Distribute deodorants and odor masking agents.
4. Determine areas affected by odorant release.
5. **Do not** use any type of bleach (including dry, chlorine, hypochlorites or hydrogen peroxides) when addressing odorant spills or release.

6.1.3 Take corrective action to minimize event

1. Consider HazWaste contamination issues and contact Ameren Environmental as needed.
2. Review remaining odorant inventory.
3. If odorant contamination occurs, then take the following actions before leaving site:
 - 3 a. Quarantine personnel and equipment.
 - 3 b. Address personal hygiene.
 - 3 c. Dispose of or contain contaminated clothing in a sealed container.
 - 3 d. Decontaminate exposed equipment.
 - 3 e. Select an exit route for transporting contained clothing and equipment that minimizes exposure to the general public.

6.2 Low/High Odorant Intensity Situations (Odor Intensity is outside the O&M thresholds of 0.1% to 0.8% Gas-In-Air)

- 6.2.1 When possible, obtain more than one opinion on the gas odor's intensity before making decisions.
- 6.2.2 When possible, validate operation of the Odorator, by comparison, to another calibrated Odorator to verify an odorant event.
- 6.2.3 Perform additional odorant intensity testing as needed.
- 6.2.4 Review odorizer valve settings.
- 6.2.5 Review remaining odorant inventory.

UNCONTROLLED IF PRINTED

6.2.6 Determine piping configurations for possible flow channeling.

6.2.7 Consider HazWaste contamination issues. Contact Ameren Environmental as needed.

End of Instructions.

Operator Qualification (OQ) Required?

YES

1211: Odorization - Periodic Sampling

1221: Odorization - Odorizer Inspection, Testing, Preventive and Corrective Maintenance

Appendices

[Appendix A - Odorant Event Report](#)

Attachments

NONE.

Compliance Requirements

49 CFR §172.704 Hazardous Materials Table, Special Provisions, Hazardous Materials Communications, Emergency Response Information, Training Requirements, And Security Plans - Training requirements.

49 CFR §192.625 Odorization of gas.

Reference Documents

[WIGE 2.2 Working In Gaseous Environment: Personal Protective Equipment](#)

Document Rescission

ODOR 2.3 Odorization – Emergency Response, October 1, 2020

Revision Notes

Location of Changes	Summary of Changes
Paragraph 6.1.1	WIGE 2.2 replaces WWBG 2.2

Appendix A - Odorant Event Report

[\(View/download PDF version\)](#)



January 28th, 2019

Odorant Event Report

General Information

Completed By: _____ Date: _____ Time: _____
 On Site Contact: _____ Contact Phone Number: _____

Site Specific Information

Town: _____ Station Name/GPS: _____
 Meter Count: _____ Effected Gas System: _____
 Odorizer Type: _____ Leak Call Count: _____

Site Issues *(Complete all that apply)*

Safe Zone/Secure Zone Required. Yes No
 Under or Over Odorized? Under Over N/A
 Odorant Leak? Yes No
 Pickling Procedures? Yes No
 If yes to Odorant Leak - Leak Contained. Yes No
 Liquid or Vapor Release? Liquid Vapor
 Outside Entities on Scene? Police Fire Dept. Media EPA

Damage/Cause of Event: _____

Injury/Accident Associated. _____

Facilities Evacuated. *(List)* _____

High Profile Customers on System? *(List)* _____

Actions Taken *(Complete all that apply)*

O&M ODOR Emer:	Yes <input type="checkbox"/>	No <input type="checkbox"/>	Quarantine Personnel & Equipment:	Yes <input type="checkbox"/>	No <input type="checkbox"/>
Purge Plan:	Yes <input type="checkbox"/>	No <input type="checkbox"/>	OH2 Sampling:	Yes <input type="checkbox"/>	No <input type="checkbox"/>
Odorator Intensity Test:	Yes <input type="checkbox"/>	No <input type="checkbox"/>	Sniff Test:	Yes <input type="checkbox"/>	No <input type="checkbox"/>
Odorant Spill Kit:	Yes <input type="checkbox"/>	No <input type="checkbox"/>	Returned to Service:	Yes <input type="checkbox"/>	No <input type="checkbox"/>
Update Maximo with Remaining Odorant Inventory <i>(if necessary)</i>			Yes <input type="checkbox"/>	No <input type="checkbox"/>	

Follow-up Action

Odorant Intensity Reading *(readily detectable)*

OH2 Reading *(bMMSCF)*

As Found: _____

As Found: _____

As Left: _____

As Left: _____

TimeLine of Events

Date & Time: _____ Location: _____ OH2**(bMMSCF)**: _____ Odorator**(readily detectable)**: _____

Date & Time: _____ Location: _____ OH2**(bMMSCF)**: _____ Odorator**(readily detectable)**: _____

Date & Time: _____ Location: _____ OH2**(bMMSCF)**: _____ Odorator**(readily detectable)**: _____

Date & Time: _____ Location: _____ OH2**(bMMSCF)**: _____ Odorator**(readily detectable)**: _____



TimeLine of Events – Continued

January 28th, 2019

Date & Time: _____ Location: _____ OH2(b/MMSCF): _____ Odorator(readily detectable): _____

Date & Time: _____ Location: _____ OH2(b/MMSCF): _____ Odorator(readily detectable): _____

Date & Time: _____ Location: _____ OH2(b/MMSCF): _____ Odorator(readily detectable): _____

Date & Time: _____ Location: _____ OH2(b/MMSCF): _____ Odorator(readily detectable): _____

Date & Time: _____ Location: _____ OH2(b/MMSCF): _____ Odorator(readily detectable): _____

Date & Time: _____ Location: _____ OH2(b/MMSCF): _____ Odorator(readily detectable): _____

Date & Time: _____ Location: _____ OH2(b/MMSCF): _____ Odorator(readily detectable): _____

Date & Time: _____ Location: _____ OH2(b/MMSCF): _____ Odorator(readily detectable): _____

Date & Time: _____ Location: _____ OH2(b/MMSCF): _____ Odorator(readily detectable): _____

Date & Time: _____ Location: _____ OH2(b/MMSCF): _____ Odorator(readily detectable): _____

Date & Time: _____ Location: _____ OH2(b/MMSCF): _____ Odorator(readily detectable): _____

Date & Time: _____ Location: _____ OH2(b/MMSCF): _____ Odorator(readily detectable): _____

Date & Time: _____ Location: _____ OH2(b/MMSCF): _____ Odorator(readily detectable): _____

Date & Time: _____ Location: _____ OH2(b/MMSCF): _____ Odorator(readily detectable): _____

Date & Time: _____ Location: _____ OH2(b/MMSCF): _____ Odorator(readily detectable): _____

Date & Time: _____ Location: _____ OH2(b/MMSCF): _____ Odorator(readily detectable): _____

Date & Time: _____ Location: _____ OH2(b/MMSCF): _____ Odorator(readily detectable): _____

Date & Time: _____ Location: _____ OH2(b/MMSCF): _____ Odorator(readily detectable): _____

Date & Time: _____ Location: _____ OH2(b/MMSCF): _____ Odorator(readily detectable): _____

Date & Time: _____ Location: _____ OH2(b/MMSCF): _____ Odorator(readily detectable): _____

Date & Time: _____ Location: _____ OH2(b/MMSCF): _____ Odorator(readily detectable): _____

Date & Time: _____ Location: _____ OH2(b/MMSCF): _____ Odorator(readily detectable): _____

Date & Time: _____ Location: _____ OH2(b/MMSCF): _____ Odorator(readily detectable): _____

Date & Time: _____ Location: _____ OH2(b/MMSCF): _____ Odorator(readily detectable): _____

Date & Time: _____ Location: _____ OH2(b/MMSCF): _____ Odorator(readily detectable): _____

Date & Time: _____ Location: _____ OH2(b/MMSCF): _____ Odorator(readily detectable): _____

Date & Time: _____ Location: _____ OH2(b/MMSCF): _____ Odorator(readily detectable): _____

Date & Time: _____ Location: _____ OH2(b/MMSCF): _____ Odorator(readily detectable): _____

UNCONTROLLED IF PRINTED

ODORIZATION

April 1, 2023

ODOR 3 Forms and Reference Materials

Click on the links below to open the documents.

Forms

1. [Monthly Odorization Report \(Form Number A-2513\)](#)
2. [Ameren Shipping Paper - Odorant \(Updated\)](#)
3. [Odorant Event Report 1-28-2019 Fillable](#)

References

1. [Heath Odorator 2 Operator's Manual](#)
2. [YZ - NJEX 6300G Instruction & Operating Manual](#)
3. [YZ – NJEX 7300G Instruction & Operating Manual - 06-2021](#)
4. [YZ – NJEX 8300G Natural Gas Odorization System – 02-2011](#)
5. [ZECK Z9000 User's Manual Rev 1](#)
6. [ZECK Z9000 Installation and Maintenance Manual Rev 3](#)
7. [Dosaodor-D Odorant Injection System Instruction Manual](#)
8. [ODOR Handy plus Manual Version August 2011](#)
9. [Becker ACD-300 Charcoal Deodorizer](#)
10. [GPL 750 Installation and Maintenance Manual](#)
11. [GPL 750 User's Guide](#)
12. [Service Telephone Numbers for Odorizer Systems](#)
13. [YZ-DTEX DX1000G/L Instructions & Operating Manual](#)

End of Section.

Document Rescission

ODOR 3 Odorization – Forms and Reference Materials, October 1, 2022

Revision Notes

Location of Changes	Summary of Changes
Reference Materials	Added: YZ-DTEX DX1000G/L Operating Manual.

QQAL-Operator Qualification

Operator Qualification

October 1, 2022

QQAL 0 Table of Contents

QQAL 1 Requirements

- Section 1.0 Purpose
- Section 2.0 Scope
- Section 3.0 Target Audience
- Section 4.0 Program Implementation
- Section 5.0 Identification of Covered Tasks
- Section 6.0 Abnormal Operating Conditions (AOC)
- Section 7.0 Evaluation Guidelines, AIC Employees
- Section 8.0 Disqualified, AIC Employees
- Section 9.0 Non Qualified Individuals, AIC Employees
- Section 10.0 Program Effectiveness
- Section 11.0 Management of Change
- Section 12.0 Documentation & Record Keeping, AIC Employees
- Section 13.0 Training, AIC Employees
- Section 14.0 Refresher Training, AIC Employees
- Section 15.0 Contractors
- Section 16.0 Contractor Review Meeting
- Section 17.0 Mutual Assistance
- Section 18.0 Mergers and Acquisitions
- Appendix A - Definitions

QQAL 2.1 Covered Task List

- Section 1.0 Purpose
- Section 2.0 Scope
- Section 3.0 Target Audience
- Section 4.0 Cover Task List

QQAL 2.2 Cover Tasks AOCs

- Section 1.0 Purpose
- Section 2.0 Scope

UNCONTROLLED IF PRINTED

Section 3.0 Target Audience

Section 4.0 Covered Task AOC's

[QQAL 4 Forms and Reference Materials](#)

Forms

[Ameren Illinois Contractor Hiring Checklist](#)

[OQ Task Disqualification Notice](#) – Updated

[OQ Contractor OQ Plan Approval Form](#)

References

Attachments

Document Rescission

End Table of Contents.

Revision Notes

Location of Changes	Summary of Changes
Entire Document	Format of document has been changed to match the format of October 2022 Issue

1.0 Purpose

- 1.1 This Operator Qualification (OQ) program establishes the requirements and responsibilities for the qualification of individuals who perform covered tasks that may impact the safety or integrity of the pipeline facilities.
- 1.2 The program establishes procedures to ensure that personnel who perform covered tasks are qualified or are working under the direct observation of a qualified individual, within the limits of identified Span of Control.
- 1.3 The program also addresses the requirement that individuals performing covered tasks must have the ability to recognize and react to abnormal operating conditions.
- 1.4 This document meets the federal requirements of 49 CFR Part 192; Subpart N, and Illinois Administrative Code 520.

2.0 Scope

This document addresses the following:

[3.0 Target Audience](#)

[4.0 Program Implementation](#)

[5.0 Identification of Covered Task](#)

[6.0 Abnormal Operating Conditions](#)

[7.0 Evaluation Guidelines, AIC Employees](#)

[8.0 Disqualification, AIC Employees](#)

[9.0 Non-Qualified Individuals, AIC Employees](#)

[10.0 Program Effectiveness](#)

[11.0 Management of Change](#)

[12.0 Documentation & Record Keeping, AIC Employees](#)

[13.0 Training, AIC Employees](#)

[14.0 Refresher Training, AIC Employees](#)

[15.0 Contractors](#)

[16.0 Contractor Review Meeting](#)

[17.0 Mutual Assistance](#)

[18.0 Mergers and Acquisitions](#)

Appendices

[Appendix A - Definitions](#)

3.0 Target Audience

- Gas Supervisors
- Gas Field Personnel
- Gas Tech Services (GTS) Personnel
- Gas Tech Services (GTS) Supervisors
- Operator Qualification Personnel
- Gas Storage Personnel and Supervisors

4.0 Program Implementation

- 4.1 Ameren Illinois (AIC) Gas Operator Qualification (OQ) Department is responsible for the implementation and administration of the OQ Plan and will review the Plan at least once each calendar year, not to exceed 15 months.

5.0 Identification of Covered Tasks

- 5.1 The AIC Covered Task List is based on a review of the ASME B31Q Pipeline Personnel Qualification Standard (2016 Edition), to assist in the determination of covered tasks.
- 5.2 During this review, AIC determines which of the ASME B31Q tasks apply and which do not apply to AIC based on operator specific facilities and procedures.
- 5.3 A task that meets the requirements of the four-part test which is not referenced in the ASME B31Q will be added as an AIC specific covered task. The criteria for the four-part test are as follows:
- 5.3.1 Is the task performed on a pipeline facility?
 - 5.3.2 Is the task an operations or maintenance task?
 - 5.3.3 Is the task performed as a requirement of 49 CFR 192?
 - 5.3.4 Does the task affect the operation or integrity of the pipeline?
- 5.4 Upon revision of the B31Q Standard, AIC Gas OQ Department will review the covered task list in Appendix A of the Standard to determine any:
- 5.4.1 Newly identified tasks to be implemented at AIC as new Covered Tasks.
 - 5.4.2 Revised or removed tasks which result in revision or removal of AIC Covered Tasks.
 - 5.4.3 Tasks that are no longer performed at AIC due to changes in pipeline facilities or procedures. These tasks will be removed from the AIC Covered Task list.
- 5.5 The AIC Covered Task list is found in [OQAL 2.1](#) of this part. Each Covered Task will contain the following:
- 5.5.1 Covered Task Number and Description.
 - 5.5.2 Re-evaluation Interval.
 - 5.5.3 Initial and Subsequent Evaluation Method.
 - 5.5.4 Span of Control.

6.0 Abnormal Operating Conditions (AOC)

- 6.1 An AOC is a condition that may indicate a malfunction of a component or deviation from normal operations that may; (a) indicate a condition exceeding design limits, or (b) result in a hazard(s) to persons, property, or the environment.

- 6.2 AIC has adopted the generic list of AOC's contained in Appendix E of the ASME B31Q Standard as follows:
 - 6.2.1 Unplanned escape of product from a pipeline.
 - 6.2.2 Fire or explosion.
 - 6.2.3 Unexplained/Unplanned pressure deviation (increase, decrease, high, low, absent).
 - 6.2.4 Unexplained/Unplanned flow rate deviation (high flow, low flow, not flow).
 - 6.2.5 Pipeline damage (line hit, lightning strikes, tornado, flood, earthquakes, etc.).
 - 6.2.6 Activation of a safety device (pressure relief, emergency shutdown, high pressure shutdowns, case pressure shutdown, high temperature shutdown, etc.).
 - 6.2.7 Unexplained/Unplanned status change (unit start-up, unit shutdown, valve open, valve close, etc., without being directed to do so).
 - 6.2.8 Communications, control system or power interruption or failure.
 - 6.2.9 Inadequate odorization or reports of gas odor.
- 6.3 AIC maintains task specific AOC's where applicable in the Covered Task Summary documents.

7.0 Evaluation Guidelines, AIC Employees

7.1 Evaluation Criterion

- 7.1.1 The qualification criterion used to qualify an individual to perform a covered task and to determine that the individual is able to recognize and react to AOCs may consist of a number of evaluation materials such as:
 1. ASME B31Q Pipeline Personnel Qualification Standard.
 2. AIC Developed Examinations.
 3. AIC Outsourced Examinations.
 4. Ameren Illinois Operating & Maintenance (O&M) Plan.
 5. Manufacturer's Instructions.

7.2 Evaluator and Proctor Selection and Testing Restrictions

- 7.2.1 Evaluators will be selected based on their knowledge of the covered task. A list of approved evaluators, along with their credentials will be kept on file by AIC Gas OQ Department.
- 7.2.2 Any written or computer-based exams will be taken under the observation of an evaluator or an approved exam proctor. A list of approved proctors will be kept on file by AIC Gas OQ Department.
- 7.2.3 Proctors and Evaluators must ensure that individuals being evaluated do not use cell phones, cameras, or other recording devices during written examinations.
- 7.2.4 The AIC Gas O&M Plan or other pertinent instructions may be referenced during performance evaluations, but only as provided by the AIC Gas OQ Department.

7.3 Evaluation Process

7.3.1 The evaluator will use one or more of the Evaluation Methods and the established evaluation criterion to evaluate an individual's ability to perform a covered task.

7.3.2 An individual who is qualified under the evaluation process will be able to:

1. Perform the covered task.
2. Recognize and react to an AOC.

7.4 Evaluation Process, Initial

7.4.1 The initial evaluation process will be used to evaluate the knowledge, skills and abilities of each employee performing covered tasks and their ability to recognize and react to AOCs

7.5 Evaluation Process, Failure to Qualify 1st Attempt

7.5.1 When an employee is unable to successfully complete a covered task, the following process will be implemented.

1. The failure will be communicated to the employee and to their Supervisor.
2. AIC Gas OQ Staff will recommend remedial training required for the employee. This training may include a review of applicable procedures, supplemental classroom training, Computer Based Training (CBT), and/or additional OJT (on the job training) on the covered task, under the guidance of a qualified employee.
3. The scope of remedial training required will determine the time frame that the employee must wait prior to being re-evaluated for qualification. This will typically be a period of 5 calendar days but may be adjusted depending on the remedial training needs of the employee.

7.6 Evaluation Process, Failure to Qualify 2nd Attempt

7.6.1 When an employee fails the 2nd attempt to qualify on a covered task:

1. The failure will be communicated to the employee and to their Supervisor.
2. A meeting will be arranged by AIC OQ Department and the local Gas Supervision within 30 days of the 2nd failure.
 - 2 a. At that time a field evaluation will be arranged.
 - 2 b. A determination will be made regarding the remedial action to be taken, i.e., retraining or reassignment into another job classification.

7.7 Evaluation Methods

7.7.1 An individual's knowledge, skills and abilities to perform a covered task and to recognize and react to AOCs will be evaluated by a documented process using one or more of the evaluation methods. The qualification methods and the acceptable criteria are as follows:

Evaluation Method	Acceptance Criteria
Written Examination	80%
Oral Examination	80%

Hands-on Examination	Pass/Fail
Field Observation	Pass/Fail

- 7.7.2 Hands-on examinations may involve observation supplemented by appropriate queries that can be made during:
 1. Performance on the job.
 2. On-the-job training.
 3. Field Simulations.
- 7.7.3 Field Observation may include work performed in the field as observed by Gas Quality Assurance (QA) Consultant, Gas OQ staff, or Gas Supervisor.
- 7.7.4 The evaluation processes selected for initial and subsequent evaluations are based on a DIF (Difficult, Importance, Frequency of performance) Analysis for AIC and is documented in the AIC Covered Task List in [OQAL 2.1](#).

7.8 Re-Evaluation Intervals

- 7.8.1 AIC will utilize the DI (Difficulty and Importance) Analysis referenced in the Appendix A of the ASME B31Q Covered Task list, as the basis for establishing re-evaluation intervals.
- 7.8.2 AIC will conduct a Frequency Analysis for each Covered Task to establish a DIF Analysis to determine the proper re-evaluation interval for each Covered Task for AIC.
- 7.8.3 If a change is made to a re-evaluation interval for a Covered Task, the change will be effective for an employee at the time that individual becomes due for and is requalified on the covered task.
- 7.8.4 Subsequent re-evaluation of an individual's qualification to perform covered tasks may not exceed the re-evaluation intervals listed in the Covered Task List plus an additional grace period of 3 months.

7.9 Reasons to Re-evaluate Qualification

- 7.9.1 There may be a reason to believe that an individual is no longer qualified to perform a covered task. Some possible reasons an individual's qualification(s) may need to be reevaluated:
 1. Loss of motor skills, vision, impairment, etc.
 2. Statement from a physician.
 3. Unsatisfactory performance of a covered task.
 4. Off work for more than 12 months.
- 7.9.2 If there is reason to believe that an individual is no longer qualified to perform a covered task, the individual will be re-evaluated in accordance with the Evaluation Process.
- 7.9.3 AIC Gas OQ Department will provide instructions to the Gas Supervisor who has the responsibility for determining when such an evaluation is necessary.

7.10 Reportable Incident Re-Evaluation

UNCONTROLLED IF PRINTED

7.10.1 If there is reason to believe that an individual's performance of a covered task may have contributed to a reportable incident, as defined in [INCD 1](#), the following process is to be used to determine if a reevaluation is required:

1. The individual's qualification will be immediately suspended for the appropriate covered task until an investigation can be conducted to determine if the employee's performance contributed to the incident.
2. An investigation of the incident will be completed according to [INVE 2.1](#).
3. If the investigation indicates that employee's performance did not contribute to the incident, then a re-evaluation of the employee is not required, and the qualification will be reinstated.
4. If the investigation indicates that there is reason to believe that an individual's performance of a covered task contributed to the incident, then the individual will be disqualified, and will require a successful re-qualification for the covered task, as outlined in the Disqualification, AIC Employees section of this procedure.

7.10.2 AIC Gas OQ Staff will review the following for all reportable incidents:

1. Identify the individuals involved.
2. Identify the covered tasks and/or AOCs involved.
3. Determine if all actions taken were in accordance with the AIC O&M Plan.
4. Identify and implement any revisions to the OQ Plan that may prevent a recurrence of the incident.

8.0 Disqualification, AIC Employees

8.1 When an employee is disqualified for a covered task, the OQ Task Disqualification Form (See [OQAL 4](#)) will be completed and promptly communicated with Gas Operations.

8.2 When an employee is disqualified to perform a covered task, the following process will be implemented.

8.2.1 AIC OQ Staff will recommend remedial training required for the employee. This training may include a review of applicable procedures, supplemental classroom training, CBT, and/or additional OJT (on the job training) on the covered task(s), under the guidance of a qualified employee.

8.2.2 The scope of remedial training required will determine the time frame that the employee must wait prior to being re-evaluated for qualification. This will typically be a period of 5 calendar days, but may be adjusted depending on the remedial training needs of the employee.

8.2.3 Re-evaluation for a disqualified employee will be conducted using the same evaluation methods used for the initial qualification.

8.2.4 Remedial training completed will be documented in the Reinstatement section of the OQ Task Disqualification Notice Form, along with the date.

8.2.5 Disqualification and any subsequent requalification of a covered task will be communicated both to the affected employee and to their Supervisor.

9.0 Non-Qualified Individuals, AIC Employees

- 9.1 Non-Qualified individuals are allowed to perform covered tasks under certain circumstances, including, but not limited to, the non-qualified individual's participation in OJT training or when working as part of a crew.
- 9.2 Non-Qualified individuals may perform a covered task if all three of the following conditions are met:
 - 9.2.1 A qualified individual is assigned to direct and observe non-qualified individual(s) during the performance of a covered task. Direct and observe means that the qualified individual must be focused on the task at hand.
 - 9.2.2 A qualified individual is able to recognize and react to an AOC and take immediate corrective action when necessary.
 - 9.2.3 The ratio of non-qualified individuals to a qualified individual shall not exceed the span of control ratio as identified in the Covered Task List in [OQAL 2.1](#).
 - 9.2.4 A Non-qualified individual may not weld on steel pipe, join PE pipe, or perform any other task where the span of control is 1:0.

10.0 Program Effectiveness

- 10.1 At an interval of 3 years not to exceed 39 months, the OQ program shall be reviewed to appraise its effectiveness.
 - 10.1.1 This review shall determine whether the program is being implemented as documented.
 - 10.1.2 Appraise whether it is effective as implemented. AND
 - 10.1.3 Include provisions to update the OQ program based on the results from the implementation and effectiveness appraisals.
- 10.2 Two required measures will be tracked to appraise program effectiveness:
 - 10.2.1 Number of individuals performing covered tasks found to have contributed to an event or action that adversely affects the safety or integrity of the pipeline
 - 10.2.2 Number of pipeline damages/leaks attributed to the performance of damage prevention or excavation activities by employees or contractor employees of Ameren Illinois.
- 10.3 In addition to the two required measures, the following measures should also be considered to appraise program effectiveness:
 - 10.3.1 Effectiveness of the methods of evaluation for individual qualifications.
 - 10.3.2 Number of events or actions that adversely affect the safety or integrity of the pipeline within a specific timeframe.
 - 10.3.3 Number of individuals with qualifications suspended or revoked.
 - 10.3.4 Number of reasonable cause investigations.
 - 10.3.5 Review of feedback received from evaluators, employees, contractors, other affected individuals, and ICC audits regarding:
 - 1. Training.
 - 2. Evaluation issues.
 - 3. Procedural issues.
 - 4. AOC recognition and reaction issues.

5. Subsequent qualification intervals effectiveness.
6. Span of control effectiveness.

10.3.6 Review of the findings of the Quality Assurance program.

10.4 A review of the DIF Analysis for each Covered Task will be conducted during the Program Effectiveness review to determine if any changes are needed to the subsequent evaluation method or interval

11.0 Management of Change

11.1 AIC Gas OQ Department staff will communicate all changes to covered tasks to the individuals performing covered task(s).

11.2 These changes may include, but are not limited to:

- 11.2.1 Revisions to AIC policies or procedures.
- 11.2.2 Changes to State or Federal regulations.
- 11.2.3 New equipment, material and/or technology.

11.3 Changes will be evaluated for impact and communicated to qualified individuals according to the following protocol

11.3.1 Low Impact Change:

1. Low Impact changes, such as grammatical changes, have no impact on the completion of a covered task.
2. No communication of the change is required.

11.3.2 Medium Impact Change:

1. Medium Impact changes include minor company policy changes, or other changes that may impact the performance of a covered task.
2. Requires documented notification to affected individuals, typically through written communication such as Gas Training Updates or Material Updates.

11.3.3 High Impact Change:

1. High Impact changes include Significant Revisions to the Gas O&M Plan Procedures.
2. Requires documented communication to affected individuals before the change is implemented.
3. A record of the review of the communication by AIC Qualified individuals will be maintained electronically in the Insight Learning Management System.

11.4 AIC will communicate to the ICC Pipeline Safety Program when significant OQ written program changes are made. Significant changes include but are not limited to:

- 11.4.1 Increasing evaluation intervals,
- 11.4.2 Increasing span of control ratios,
- 11.4.3 Eliminating covered tasks,
- 11.4.4 Mergers and/or acquisition changes,
- 11.4.5 Evaluation method changes (such as written vs. observation), or
- 11.4.6 Wholesale changes made to the OQ Plan.

12.0 Documentation & Record Keeping, AIC Employees

12.1 AIC will ensure all employees' qualification records are maintained using electronic and/or hard copy. These records will contain:

- 12.1.1 The individual being qualified.
- 12.1.2 The covered tasks the individual is qualified to perform.
- 12.1.3 The method of evaluation per task.
- 12.1.4 Scores of written test.
- 12.1.5 The date qualification was completed.
- 12.1.6 The due date for the next subsequent re-qualification.
- 12.1.7 The name of evaluator.

12.2 Records of prior qualification of individuals including those no longer performing covered tasks shall be retained for a period of up to 8 years, 5 years beyond the expiration of the qualification.

13.0 Training, AIC Employees

13.1 All AIC gas apprentices will be evaluated for qualification on covered tasks as they progress through the AIC Gas Apprentice Training Program.

13.2 AIC Gas Training staff will determine the training requirements based on the job classification requirements, for initial training.

13.3 The initial method of evaluation for each covered task is identified in the Covered Task List in [OQAL 2.1](#).

13.4 Individuals that perform covered tasks will also be trained and evaluated to ensure that they possess the knowledge, skills and abilities to:

- 13.4.1 Follow the requirements of this rule.
- 13.4.2 Carry out the procedures in the AIC O&M Plan including emergency response procedures.
- 13.4.3 Use instruments and equipment related to the covered task they perform.
- 13.4.4 Know all the characteristics and hazards of the gas transported, including flammability range, toxicity, olfactory and corrosive properties.
- 13.4.5 Recognize all potential ignition sources.
- 13.4.6 Recognizing all AOCs that are likely to cause emergencies including gas leaks and equipment or facility malfunction or failure. Predict potential consequences of these conditions and take appropriate corrective steps.
- 13.4.7 Take steps necessary to control any accidental release of gas and to minimize the potential for a fire or explosion.
- 13.4.8 Know the proper use of firefighting procedures and equipment, fire suits and breathing apparatus by utilizing, where feasible, a simulated pipeline emergency condition.

14.0 Refresher Training, AIC Employees

- 14.1 In addition to OQ evaluations, individuals that perform covered tasks will receive refresher training.
- 14.2 This refresher training will focus on core areas of a specific covered task or a group of related covered tasks.
- 14.3 Topics may be chosen by applicability to work groups or based on field performance observations, with at least one refresher training topic covered each calendar year.
- 14.4 In addition, refresher training on Leak Management Procedures will be conducted on an annual basis.
- 14.5 Additional refresher training will be given when it is determined as being necessary.

15.0 Contractors

- 15.1 A contractor performing a covered task that is not operating under the AIC OQ Plan will be required to forward their company Operator Qualification Plan to AIC Gas OQ Department and AIC Construction Services prior to the beginning of any work on AIC property.
- 15.2 AIC OQ staff is responsible for the evaluation of the contractor's OQ Plan. Once the contractor OQ Plan has been evaluated and approved, the contractor's name will be placed on an "Approved Contractor List".
- 15.3 AIC Gas OQ staff will evaluate Contractor OQ plans that use the **Energy World Net (EWN)** industry OQ Consortium as the basis for qualification.
- 15.4 The AIC contractor OQ Plan evaluation will consist of the following items:
 - 15.4.1 Drug and Alcohol Plan - Ensure that the contractor has a compliant Drug and Alcohol Plan and is in a Satisfactory Status.
 - 15.4.2 Environmental/Safety Violation Disclosure Form - Ensure this form has been completed and received by AIC.
 - 15.4.3 Use of Subcontractors - Ensure that any Subcontractors that are used are either qualified under the Contractor's OQ Plan, or that the Subcontractor has their own OQ Plan. All Subcontractor OQ Plans must be submitted to and approved by AIC Gas OQ Department prior to performing work.
 - 15.4.4 Covered Tasks: Ensure that the Contractors Covered Tasks align with the approved OQ Consortium provider and are equivalent to the AIC Covered Task List.
 - 15.4.5 Span of Control: Ensure that the Contactor's Span of Control is aligned with the approved OQ Consortium provider or more stringent.
 - 15.4.6 Requalification Interval: Ensure that the Contractor's requalification intervals are aligned with the approved OQ Consortium provider, or more frequent.
 - 15.4.7 Abnormal Operation Conditions: Ensure that the Contractor's AOCs align with the approved OQ Consortium provider, or the list of AOCs in the AIC OQ Plan.
 - 15.4.8 Disqualification Procedure: Ensure that the Contractor OQ Plan defines when individuals will be suspended or disqualified from performing a covered task.
 - 1. This must include a provision for suspending the qualification of individuals whose performance of a covered task may have contributed to a reportable incident, as defined in **INCD 1**.

2. The Contractor OQ Plan must also specify a minimum duration between evaluation attempts, after a disqualification or failure to qualify. This shall be a minimum duration of 1 day depending on remedial training required.

15.4.9 Management of Change: Ensure that the Contractor's OQ Plan contains a provision for communicating changes in pertinent AIC policies or procedures.

15.4.10 Qualification Records: Ensure that the Contractor's OQ Plan defines a record retention period of at least 5 years for individual's prior qualification records and for those individuals no longer performing covered tasks.

15.4.11 Documentation of the Contractor's OQ Plan Review and approval, including resolution of any gaps noted, will be documented on the AIC Contractor OQ Plan Review Form (See [OQAL 4](#)).

15.5 Hiring Requirements for Contractors Qualified Under the AIC OQ Plan

15.5.1 These requirements apply to the hiring of all contractors who will perform covered task work on AIC gas facilities and are not covered under an OQ plan.

15.5.2 These contractors are working under the AIC OQ Plan/Task List as follows:

1. Typically receiving an Ameren ID # / Badge
2. AIC OQ Staff will confirm training and perform OQ evaluations for these contractors. OQ Credentials will be documented using the AIC Covered Task List.
3. OQ Credentials documented in Insight LMS (where an Ameren ID is issued)
4. The employee who initiates the hiring of these contractors is someone from Region Operations or one of the Gas Services and Operations groups, etc.
5. An example of such contractors would be temporary employees hired through Zempleo/Guidant, or spray-applied painting contractors.

15.5.3 Subsequent OQ requirements will be monitored by the AIC Gas OQ Department.

16.0 Contractor Review Meeting

16.1 An initial review meeting will be conducted by AIC Construction Services prior to the commencement of a new contractor performing work on AIC facilities.

16.2 This meeting will review and identify any required training and testing for the contractor employees on AIC specific requirements.

16.3 In addition, this OQ Review meeting will cover the following:

16.3.1 Covered Tasks:

1. Contractor personnel shall be qualified for the core tasks identified for the work to be performed.

16.3.2 Span of Control:

1. All contractors initially working under Span of Control should work toward qualification after training and OJT.

16.3.3 Suspension or Loss of Qualification:

1. AIC must be notified of any contractor personnel who becomes disqualified to perform a covered task while working for AIC.

2. AIC and the contractor will investigate any incidents that may result in the loss or suspension of qualifications.
3. AIC has the right to determine if an individual will be allowed to continue work on its facilities.

16.3.4 Communication of Change:

1. AIC will notify all contractor personnel of pertinent changes in the same manner as it notifies AIC employees.

16.3.5 Record Keeping

1. Qualification records of all contractor employees shall be sent to AIC Gas OQ Department prior to work beginning on AIC facilities
2. All qualifications records of the contractor's personnel shall be kept by the following:
 - 2 a. AIC Gas OQ Department
 - 2 b. Contractor - OQ Records must be accessible on the job site.

16.3.6 Additional Responsibilities of the Contractor

1. It is the responsibility of the Contractor to notify AIC Construction Services of any individuals that are non-qualified and/or new to the job site.
2. AIC retains the right to allow or disallow any individual(s) or contractor(s) on the property.

17.0 Mutual Assistance

17.1 Employees, contractors, subcontractors and employees of other companies providing mutual aid to AIC as part of a protracted emergency must follow the requirements of the AIC O&M Plan.

17.2 AIC will identify the scope of work for the mutual response and the associated Covered Tasks to be performed.

17.3 AIC will request the following information for individuals responding to a mutual aid request:

17.3.1 List of qualified employees with covered tasks they are qualified to perform.

17.3.2 Evaluation process.

17.3.3 Date of qualifications and expiration dates.

17.4 Upon review of this information, AIC will determine and administer any training and qualification evaluations required for the responding parties prior to beginning work to ensure they have the knowledge, skills, and ability to perform the required work.

18.0 Mergers and Acquisitions

18.1 A. In the event of a merger or acquisition, AIC and the newly merged or acquired company will initially operate under separate OQ Plans until a consolidation review is performed.

18.2 As soon as practical, a consolidation review will be conducted of the OQ Plans for each company to identify if the OQ Plans will remain separate or be merged into one OQ Plan. The review may identify any best practices from the merged or acquired companies which should be incorporated into the AIC OQ Plan.

18.3 If the consolidation review results in a merged OQ Plan, AIC will identify and conduct any supplemental training and qualification evaluations required for all impacted individuals who were previously qualified under a changed OQ Plan as a result of the consolidation.

18.4 Records of prior qualification for qualified individuals who are acquired with the merger or acquisition, including those no longer performing covered tasks, shall be retained for a period of up to 8 years, 5 years beyond the expiration of the qualification.

End of Instructions.

Operator Qualification (OQ) Required?

NO

Appendices

[Appendix A - Definitions](#)

Attachments

NONE.

Compliance Requirements

49 CFR §192.805 Qualification of Pipeline Personnel: Qualification Program

49 CFR §192.809 Qualification of Pipeline Personnel: General

Reference Documents

[INCD 1 Incident Reporting: Requirements](#)

[INVE 2.1 Investigation of Incidents: Incident Investigation](#)

[OQAL 2.1: Operator Qualification: Covered Task List](#)

[OQAL 4: Operator Qualification: Forms and Reference Materials](#)

Document Rescission

OQAL 1 Operator Qualification: Requirements, October 1, 2022

Revision Notes

Location of Changes	Summary of Changes
Covered Task	Update: 1061 – Span of Control – 1.2 or Manufacture's Recommendation. Added: 1281 Mobile Gas Leakage Survey - Optical Methane A004 Mobile Gas Leakage Survey: Laser Spectroscopy

Appendix A - Definitions

<u>Term</u>	Definition
Ability	The mental and physical capacity to perform a task.
Abnormal Operating Condition (AOC)	<p>A condition that may indicate a malfunction of a component or deviation from normal operations that may:</p> <ol style="list-style-type: none"> 1. Indicate a condition exceeding design limits; or 2. Result in a hazard(s) to persons, property, or the environment.
Affected Individual	An individual who performs a covered task(s) or who has qualification program implementation responsibility.
Covered Task	<p>An activity, identified by the Operator, that:</p> <ol style="list-style-type: none"> 1. Can affect the safety or integrity of the pipeline. 2. Is performed on a pipeline facility. 3. Is an operations or maintenance task. 4. Is performed as a requirement of 49 CFR 192. 5. Affects the operation or integrity of the pipeline.
Covered Task Summary	Contains task specific information, AOC's and O&M procedure references associated with each covered task.
Commission	To verify that pipeline equipment or components function within specified parameters, prior to or during placing in service.
DI Analysis	An analysis that explores the difficulty (D) and importance (I) of each task.
DIF Analysis	An analysis that explores the Difficulty (D), Importance (I), and Frequency (F), of each task.
Direct and Observe	The process by which a qualified individual oversees the work activities of a non-qualified individual(s), and is able to take immediate corrective action when necessary.
Evaluation	A process established to determine an individual's ability to perform a covered task(s). The term can be used to refer to the process, examination instruments(s) or both. The process may entail one or more evaluation method or one or more distinct evaluation instruments.
Evaluation Criteria	The specific knowledge and skill an individual must possess and demonstrate to be qualified to perform a covered task.

Evaluator	An individual who has the qualifications and has been identified to conduct performance evaluations and written / oral evaluations to determine if the individual is qualified to perform a task(s), and recognize and react to abnormal operating conditions.
Knowledge	A body of information applied directly to the performance of a task.
Mutual Aid	Pipeline operator personnel assistance (aid) provided to another pipeline operator in the performance of covered task(s).
On the Job Training (OTJ)	Instruction at or near the work setting and properly documented in individuals file.
Performance	Demonstration of the knowledge, skill or abilities required for a task(s).
Personnel	Individuals who may perform covered task(s).
Pipeline	All parts of the facility through which gas moves in transportation, including pipe, valves, appurtenances attached to pipe, compressors, metering stations, regulator stations, delivery stations, holders, and fabricated assemblies.
Proctor	An individual selected to administer a written examination.
Qualified	An individual who has been evaluated and can: <ol style="list-style-type: none"> 1. Perform assigned covered task(s); and 2. Recognize and react to abnormal operating conditions.
Safety or Integrity	The state of a pipeline that demonstrates either operational safety (as affected by maintenance, construction, and operating activities) or the ability to withstand the stresses imposed during operations.
Skill	The ability to perform acquired mental and physical activities to perform a task(s).
Span of Control	The maximum number of non-qualified individuals that a qualified individual is allowed to direct and observe.
Subject Matter Resource	An individual(s) that possesses knowledge and experience in the process / discipline and who is recognized as an expert by Ameren Illinois management.

Subsequent Qualification	A process to evaluate / test, an individual(s) who is currently qualified to perform a covered task(s).
Suspension	Temporary cancellation of qualifications of a qualified individual from performing identified covered task(s).
Task	A defined unit of work, having an identifiable beginning and end, and specifications that are observable and measurable.
Training	Instruction designed around tasks and the related knowledge and skills needed for competent performance.
Training Program	The written description, processes, procedures, training materials, evaluations, etc. that establish and document training identified by Ameren Illinois.

Operator Qualification

April 1, 2023

OQAL 2.1 Covered Task List**1.0 Purpose**

This section lists the Covered Task List in order from lowest Task Number to Highest.

2.0 Scope

This document addresses the following:

[3.0 Target Audience](#)[4.0 Cover Task List](#)**3.0 Target Audience**

- Gas Supervisors
- Gas Field Personnel
- Gas Tech Services (GTS) Personnel
- Gas Tech Services (GTS) Supervisors
- Gas Storage Field Supervisors
- Gas Storage Field Personal
- Gas Operator Qualification Personnel

4.0 Covered Task List

Number	Covered Task	Re-eval Intervals	Initial Method of Evaluation	Subsequent Method of Evaluation	Span of Control
0001	Measure Structure-to-Electrolyte Potential	5 yrs	P&W/O	W/O	1:1
0011	Conduct Close Interval Survey	3 yrs	P&W/O	W/O	1:1
0021	Measure Soil Resistivity	3 yrs	P&W/O	W/O	1:1
0031	Inspect and monitor Galvanic Ground Beds/Anodes	5 yrs	P&W/O	W/O	1:1
0041	Installation and Maintenance of Mechanical Electrical Connections	5 yrs	P&W/O	W/O	1:1
0051	Installation of Exothermic Electrical Connections	3 yrs	P&W/O	W/O	1:1

UNCONTROLLED IF PRINTED

0061	Inspect or Test Cathodic Protection Bonds	5 yrs	P&W/O	W/O	1:1
0071	Inspect or Test Cathodic Protection Electrical Isolation Devices	5 yrs	P&W/O	W/O	1:1
0081	Install Cathodic Protection Electrical Isolation Devices	5 yrs	P&W/O	W/O	1:1
0091	Troubleshoot In-Service Cathodic Protection System	3 yrs	P&W/O	W/O	1:1
0101	Inspect Rectifier and Obtain Readings	5 yrs	P&W/O	W/O	1:1
0111	Maintain Rectifier	3 yrs	P&W/O	W/O	1:1
0121	Collect Sample for Internal Corrosion Measuring	3 yrs	P&W/O	W/O	1:1
0131	Insert and Remove Coupons/Probes for Internal Corrosion Monitoring	3 yrs	P&W/O	W/O	1:1
0141	Visual Inspection for Atmospheric Corrosion	3 yrs	P&W/O	W/O	1:1
0151	Visual Inspection of Buried Pipe and Components when Exposed	3 yrs	P&W/O	W/O	1:1
0161	Visual Inspection for Internal Corrosion	3 yrs	P&W/O	W/O	1:1
0171	Measure External Corrosion	3 yrs	P&W/O	P&W/O	1:1
0181	Measure Internal Corrosion	3 yrs	P&W/O	P&W/O	1:1
0191	Measure Atmospheric Corrosion	3 yrs	P&W/O	P&W/O	1:1
0201	Visual Inspection of Installed Pipe and Components for Mechanical Damage	3 yrs	P&W/O	P&W/O	1:1
0211	Measure and Characterize Mechanical Damage on Installed Pipe and Components	3 yrs	P&W/O	P&W/O	1:1
0221	Inspect Test and Maintain Sensing Devices	3 yrs	P&W/O	W/O	1:1

UNCONTROLLED IF PRINTED

0231	Inspect Test and Maintain Programmable Logic Controllers	3 yrs	P&W/O	W/O	1:1
0301	Manually Opening and Closing Valves	3 yrs	P&W/O	W/O	1:3
0311	Adjust and Monitor Flow or Pressure-Manual Valve Operation	3 yrs	P&W/O	P&W/O	1:1
0321	Valve Corrective Maintenance	3 yrs	P&W/O	W/O	1:2
0331	Valve-Visual Inspection and Partial Operation	3 yrs	P&W/O	W/O	1:2
0341	Valve-Preventive Maintenance	3 yrs	P&W/O	W/O	1:2
0351	Pneumatic Actuator/Operator Inspection and Testing, Preventive and Corrective Maintenance	3 yrs	P&W/O	P&W/O	1:2
0361	Electric Actuator/Operator Inspection and Testing, Preventive and Corrective Maintenance	3 yrs	P&W/O	P&W/O	1:2
0371	Hydraulic Actuator/Operator Inspection and Testing, Preventive and Corrective Maintenance	3 yrs	P&W/O	P&W/O	1:2
0381	Spring Loaded Pressure Regulating Device-Inspection and Testing, Preventive and Corrective Maintenance	3 yrs	P&W/O	W/O	1:1
0391	Pilot-Operated Pressure Regulating Device-Inspection and Testing, Preventive and Corrective Maintenance	3 yrs	P&W/O	W/O	1:1
0401	Controller Type Pressure Regulating Device-Inspection and Testing, Preventive and Corrective Maintenance	3 yrs	P&W/O	P&W/O	1:1
0411	Spring Loaded Pressure Limiting and Relief Device-Inspection and Testing, Preventive and Corrective Maintenance	3 yrs	P&W/O	W/O	1:1
0421	Pilot-Operated Pressure Limiting and Relief Device-Inspection and Testing,	3 yrs	P&W/O	W/O	1:1

UNCONTROLLED IF PRINTED

	Preventive and Corrective Maintenance				
0431	Pneumatic Loaded Pressure Limiting and Relief Device-Inspection and Testing, Preventive and Corrective Maintenance	3 yrs	P&W/O	W/O	1:1
0441	Compressor Start-Up And Shutdown - Manual	3 yrs	P&W/O	W/O	1:1
0461	Compressor Preventive Maintenance	3 yrs	P&W/O	W/O	1:2
0471	Reciprocating Compressor Inspection, Testing and Corrective Maintenance	3 yrs	P&W/O	W/O	1:2
0481	Centrifugal Compressor Inspection, Testing and Corrective Maintenance	3 yrs	P&W/O	P&W/O	1:2
0491	Rotary Compressor Inspection, Testing and Corrective Maintenance	3 yrs	P&W/O	P&W/O	1:2
0551	Explosive Atmosphere Detection and Alarm System Performance Test and Corrective Maintenance	3 yrs	P&W/O	P&W/O	1:1
0561	Pressure Test - Nonliquid Medium-MAOP Less than 100 Psi	3 yrs	P&W/O	W/O	1:2
0571	Pressure Test - Nonliquid Medium-MAOP Greater than or Equal to 100 Psi	3 yrs	P&W/O	W/O	1:2
0581	Pressure Test- Liquid Medium	3 yrs	P&W/O	W/O	1:2
0591	Leak Test at Operating Pressure	3 yrs	P&W/O	W/O	1:1
0601	NDT - Radiographic Testing	3 yrs	P&W/O	W/O	1:3
0611	NDT - Liquid Penetrant Testing	3 yrs	P&W/O	W/O	1:2
0621	NDT - Magnetic Particle Testing	3 yrs	P&W/O	W/O	1:2
0631	NDT - Ultrasonic Testing	3 yrs	P&W/O	W/O	1:2

UNCONTROLLED IF PRINTED

0641	Visually Inspect Pipe and Components Prior to Installation	5 yrs	P&W/O	W/O	1:2
0681	Joining of Plastic Pipe - Stab Fittings	1yr	P&W/O	P&W/O	1:0
0691	Joining of Pipe - Non-Bottom Out Compression Couplings	1yr	P&W/O	P&W/O	1:0
0701	Joining of Pipe - Bottom Out Compression Couplings	1yr	P&W/O	P&W/O	1:0
0721	Joining of Pipe - Threaded Joints	3 yrs	P&W/O	W/O	1:2
0731	Joining of Pipe - Flange Assembly	3 yrs	P&W/O	W/O	1:4
0751	Joining of Plastic Pipe - Butt Heat Fusion: Manual	1yr	P&W/O	P&W/O	1:0
0761	Joining of Plastic Pipe - Butt Heat Fusion: Hydraulic Machine	1yr	P&W/O	P&W/O	1:0
0781	Joining of Plastic Pipe - Electrofusion	1yr	P&W/O	P&W/O	1:0
0801	Welding	1 yr	P&W/O	P&W/O	1:0
0811	Visual Inspection of Welding and Welds	3 yrs	P&W/O	P&W/O	1:1
0821	Tubing & Fitting Installation - Instrument, Control and Sampling	3 yrs	P&W/O	W/O	1:2
0861	Installation of Steel Pipe in a Ditch	3 yrs	P&W/O	W/O	1:5
0871	Installation of Steel Pipe in a Bore	3 yrs	P&W/O	W/O	1:2
0881	Installation of Steel Pipe Plowing/Pull-in	3 yrs	P&W/O	W/O	1:2
0891	Field Bending of Steel Pipe	3 yrs	P&W/O	W/O	1:1
0901	Installation of Plastic Pipe in a Ditch	3 yrs	P&W/O	W/O	1:5
0911	Installation of Plastic Pipe in a Bore	3 yrs	P&W/O	W/O	1:2

UNCONTROLLED IF PRINTED

0921	Installation of Plastic Pipe in Plowing/ Pull-in	3 yrs	P&W/O	W/O	1:2
0931	Installation of Plastic Pipe in Plowing/ Planting	3 yrs	P&W/O	W/O	1:2
0941	Install Tracer Wire	3 yrs	P&W/O	W/O	1:5
0951	Installation of Pipe Above Ground	3 yrs	P&W/O	W/O	1:3
0961	Above Ground Supports and Anchors- Inspection, Preventive and Corrective Maintenance	3 yrs	P&W/O	W/O	1:4
0971	Installation and Maintenance of Cas- ing Spacers, Vents and Seals	3 yrs	P&W/O	W/O	1:3
0981	Backfilling	3 yrs	P&W/O	W/O	1:3
0991	Coating Application and Repair - Brushed or Rolled	3 yrs	P&W/O	W/O	1:5
1001	Coating Application and Repair - Sprayed	3 yrs	P&W/O	W/O	1:5
1011	External Coating Application and Re- pair - Wrapped	3 yrs	P&W/O	W/O	1:5
1020	Perform Electrical inspection of Pipe Coating (Holiday Detection or Jeeping)	3 yrs	P&W/O	P&W/O	1:1
1041	Install Mechanical Clamps and Sleeves - Bolted	3 yrs	P&W/O	W/O	1:2
1051	Fit-Up of Weld Type Repair Sleeve	3 yrs	P&W/O	W/O	1:2
1061	Install Composite Sleeve	3 yrs	P&W/O	W/O	1:2 or Mfr's rec- om- men- dation
1071	Repair of Steel Pipe by Grinding	3 yrs	P&W/O	W/O	1:1

UNCONTROLLED IF PRINTED

1081	Tapping a Pipeline (Tap Diameter 2 Inch or Less)	3 yrs	P&W/O	P&W/O	1:2
1091	Tapping a Pipeline (Tap Diameter Greater than 2 Inch)	3 yrs	P&W/O	P&W/O	1:2
1101	Tapping a Pipeline With a Built-In Cutter	3 yrs	P&W/O	W/O	1:2
1131	Stopper (Stoppie) Pipe	3 yrs	P&W/O	P&W/O	1:2
1141	Squeeze Off Plastic Pipe	3 yrs	P&W/O	P&W/O	1:2
1151	Squeeze Off Steel Pipe	3 yrs	P&W/O	W/O	1:2
1161	Installation of Customer Meters and Regulators - Residential and Small Commercial	3 yrs	P&W/O	W/O	1:1
1171	Installing Customer Meters - Large Commercial and Industrial	3 yrs	P&W/O	W/O	1:1
1181	Installing and Maintaining Customer Pressure Regulating, Limiting, and Relief Device - Large Commercial & Industrial	3 yrs	P&W/O	W/O	1:1
1191	Maintenance of Service Valves Upstream of Customer Meter	3 yrs	P&W/O	W/O	1:1
1201	Temporary Isolation of Service Lines and Service Discontinuance	3 yrs	P&W/O	W/O	1:1
1211	Odorization - Periodic Sampling	5 yrs	P&W/O	P&W/O	1:1
1221	Odorization - Odorizer Inspection, Testing, Preventive and Corrective Maintenance	5 yrs	P&W/O	P&W/O	1:5
1231	Inside Gas Leak Investigation	1 yrs	P&W/O	P&W/O	1:1
1241	Outside Gas Leak Investigation	1 yrs	P&W/O	P&W/O	1:1
1261	Walking Gas Leakage Survey	1 yrs	P&W/O	P&W/O	1:1

UNCONTROLLED IF PRINTED

1271	Mobile Gas Leakage Survey - Flame Ionization	1 yrs	P&W/O	W/O	1:1
1281	Mobile Gas Leakage Survey - Optical Methane	1 yrs	P&W/O	W/O	1:1
1285	Inspect Water Crossing	3 yrs	P&W/O	P&W/O	1:1
1291	Locate Underground Pipelines	3 yrs	P&W/O	P&W/O	1:1
1301	Install and Maintain Pipeline Markers	5 yrs	W/O	W/O	1:4
1311	Inspect Pipeline Surface Conditions - Patrol Right of Way or Easement	5 yrs	P&W/O	W/O	1:1
1321	Damage Prevention During Excavation Activities by or on Behalf of The Operator	3 yrs	W/O	W/O	1:1
1331	Damage Prevention During Third Party Excavation or Encroachment Activities as Determined Necessary by Operator	3 yrs	W/O	W/O	1:1
1341	Provide or Assure Adequate Pipeline Support During Operator Initiated Excavation Activities	3 yrs	W/O	W/O	1:3
1351	Vault Inspection and Maintenance	3 yrs	W/O	W/O	1:1
1361	Station Emergency Shutdown System - Inspection, Testing and Corrective Maintenance	3 yrs	P&W/O	P&W/O	1:1
1371	Operate Gas Pipeline - System Control Center Operations	3 yrs(Plus)	P&W/O	P&W/O	1:1
1381	Operate Gas pipeline - Local Facility Remote-Control Operations	3 yrs	P&W/O	P&W/O	1:1
1411	Indirect Inspection Techniques	3 yrs	P&W/O	W/O	1:1
1631	Launching and/or Receiving Internal Devices (Pigs) with a temporary launcher and/or receiver for Lines Out of Service	3 yrs	P&W/O	P&W/O	1:2

UNCONTROLLED IF PRINTED

1641	Launching and/or Receiving Internal Devices (Pigs) for Lines In-Service	3 yrs	P&W/O	P&W/O	1:2
1651	Purge – Flammable or Inert Gas	3 yrs	P&W/O	W/O	1:1
1671	Inspect and Maintain a Pipeline Heater	3 yrs	P&W/O	W/O	1:1
1681	Inspect, Test, and Maintain Liquid Knockout (Dehydration) System	3 yrs	P&W/O	W/O	1:3
1691	Inspect, Test, and Maintain Glycol Dehydration System	3 yrs	P&W/O	W/O	1:3
1701	Inspect, Test, and Maintain Mole Sieve Dehydration System	3 yrs	P&W/O	W/O	1:3
A001	Service Reconnect	3 yrs	P&W/O	P&W/O	1:1
A002	Abandonment	3 yrs	P&W/O	W/O	1:1
A003	Emergency Response	1 yrs	P&W/O	P&W/O	1:1
A004	Mobile Gas Leakage Survey: Laser Spectroscopy	1 yrs	P&W/O	W/O	1:1

End of Instructions.

Operator Qualification (OQ) Required?

NO

Appendices

NONE

Attachments

NONE.

Compliance Requirements

- 49 CFR Part 192, Subpart N – Qualification of Pipeline Personnel
- IL Adm. Code Title 83, Part 520 – Training Programs for Natural Gas System Operating Personnel (General Order 204)
- ASME B31Q – Pipeline Personnel Qualification Standard

Reference Documents

NONE

Document Rescission

UNCONTROLLED IF PRINTED

QQAL 2.1 Operator Qualifications: Covered Task List, October 1, 2022

Revision Notes

Location of Changes	Summary of Changes
Covered Task	Update: 1061 – Span of Control – 1.2 or Manufacture's Recommendation. Added: 1281 Mobile Gas Leakage Survey - Optical Methane A004 Mobile Gas Leakage Survey: Laser Spectroscopy

OOAL 2.2 Covered Task AOC's

1.0 Purpose

This document lists AIC's Covered Tasks AOC's, in alphabetical order, to comply with 49 CFR Part 192 Subpart N Qualifications of Pipeline Personnel.

2.0 Scope

This document addresses the following:

[3.0 Target Audience](#)

[4.0 Covered Tasks AOC's](#)

3.0 Target Audience

- Gas Supervisors
- Gas Field Personnel
- Gas Tech Services (GTS) Personnel
- Gas Tech Services (GTS) Supervisors
- Operator Qualification
- Gas Storage Field Supervisors
- Gas Storage Field Personnel
- Gas Operator Qualifications Personnel

4.0 Covered Tasks AOC's

Abandonment		Task #	A002
Task Guidance	This task includes the steps necessary to isolate and purge mains and services when taken out of service.		
Task Specific AOC's			
<ol style="list-style-type: none"> 1. Hazardous air / gas mixture in piping 2. Isolated sections not purged 3. Gas ignition 4. Unplanned loss of service 			

Above Ground Supports and Anchors - Inspection, Preventive and Corrective Maintenance	Task #	0961
--	---------------	-------------

Task Guidance	This task includes verification that the above ground supports and anchors are installed in accordance with specifications, prior to or during placing in service. This task also includes the repair or replacement, alteration or refurbishment of above ground supports and anchors, and actions to keep the above ground supports and anchors functioning as specified.
Task Specific AOC's	
<ol style="list-style-type: none"> 1. Damage to pipe 2. Damage to coating 3. Improper pipe support 4. Corrosion 	

Adjust and Monitor Flow or Pressure-Manual Valve Operation		Task #	0311
Task Guidance	This task includes the adjustment of flow or pressure either manually or using the valve actuator at the valve site. It also includes valve identification, notifications and pressure verification.		
Task Specific AOC's			
<ol style="list-style-type: none"> 1. Inoperable valve 2. Damage to facilities 3. Pressure deviation 4. Interruption of service 5. Gas leak 			

Backfilling		Task #	0981
Task Guidance	This task includes visually inspecting backfill material, installation of pipe protective material (i.e. padding, shading, and rock shield), verification of firm support and placing backfill in lifts or layers as specified.		
Task Specific AOC's			

<ol style="list-style-type: none"> 1. Unsupported pipe 2. Unacceptable backfill materials 3. Damage to pipe 4. Damage to coating
--

Centrifugal Compressor Inspection, Testing and Corrective Maintenance		Task #	0481
Task Guidance	This task includes verification that a new, replaced, or rebuilt compressor is functioning within specified parameters, prior to or during placing in service. This task includes the repair, alteration or refurbishment of compressors. This task does not include maintenance of the compressor driver.		
Task Specific AOC's			
<ol style="list-style-type: none"> 1. Equipment Malfunction 2. Gas Leak 			

Coating Application and Repair - Brushed or Rolled		Task #	0991
Task Guidance	This task includes the surface preparation and application or repair of coatings using a brush or roller. This task includes painting to inhibit corrosion, and internal or external applications of coatings, on pipes, tanks, etc.		
Task Specific AOC's			
<ol style="list-style-type: none"> 1. Improper pipe surface preparation 2. Inadequate coverage 			

Coating Application and Repair - Sprayed		Task #	1001
Task Guidance	This task includes the surface preparation and application or repair of coatings using a sprayer. This task includes painting to in-		

	hibit corrosion, and internal or external applications of coatings, on pipes, tanks, etc.
Task Specific AOC's	
<ol style="list-style-type: none"> 1. Improper pipe surface preparation 2. Inadequate coverage 	

Collect Sample for Internal Corrosion Monitoring		Task #	0121
Task Guidance	This task includes the collection and handling of samples (gas, liquids, solids) for internal corrosion monitoring and preventing contamination of the sample.		
Task Specific AOC's			
<ol style="list-style-type: none"> 1. Debris in source valve 2. Water in gas 3. Leak on source valve 			

Compressor Preventative Maintenance		Task #	0461
Task Guidance	This task encompasses actions (e.g., lubrication, adjustment, etc.) to keep compressors operating safely and efficiently. This task does not include maintenance of the compressor driver.		
Task Specific AOC's			
<ol style="list-style-type: none"> 1. Equipment malfunction 2. Gas Leak 			

Compressor Start-up and Shutdown - Manual		Task #	0441
Task Guidance	This task includes manual startup and shutdown of a compressor, (e.g., reciprocating, centrifugal, rotary) at the driver control panel.		

Task Specific AOC's
<ol style="list-style-type: none"> 1. Equipment malfunction 2. Gas leak

Conduct Close Interval Survey		Task #	0011
Task Guidance	This task includes gathering electrical potential readings along the pipeline at specified intervals and recording data.		
Task Specific AOC's			
<ol style="list-style-type: none"> 1. AC Voltage on structure 2. Deficient P.S. reading 3. Broken test wire 4. Bad soil conditions 			

Controller Type Pressure Regulating Device - Inspection and Testing, Preventative and Corrective Maintenance		Task #	0401
Task Guidance	This task includes verification that the pressure regulating device is functioning within specified parameters, after installation, and prior to or during placing in service. This task also includes the repair or replacement, alteration or refurbishment of pressure regulating device, and actions to keep the pressure regulating device operating safely and efficiently.		
Task Specific AOC's			
<ol style="list-style-type: none"> 1. Failure to lock up 2. Lost pressure to control regulator 3. Lost mv signal to regulator 4. Inability to increase or decrease pressure 5. Excessive droop 			

Damage Prevention During Excavation Activities by or on Behalf of the Operator		Task #	1321
Task Guidance	This task includes assuring the performance of damage prevention activities during excavation activities (e.g., verifying underground pipelines are marked, providing required notifications, use of spotter/swamper to guide equipment operator, probing, hand digging, pot holing to verify location of bore-head, etc.).		
Task Specific AOC's			
<ol style="list-style-type: none"> 1. No locates 2. Missed locates 3. Not following proper JULIE procedures 			

Damage Prevention During Third Party Excavation or Encroachment Activities as Determined Necessary by Operator		Task #	1331
Task Guidance	When an operator inspects third party excavations or encroachment activities, this task includes the inspection or those activities and actions to protect the operators' facilities such as work stoppage and requiring proper support for operators' pipeline facility. (Watch and Protect)		
Task Specific AOC's			
<ol style="list-style-type: none"> 1. Damage to facility 2. Facilities not properly supported 3. Gas leak 			

Direct Examination Techniques		Task #	1421
Task Guidance	This task includes direct examination (e.g., ultrasonic examination, coating holiday testing, visual examination, etc.).		
Task Specific AOC's			
<ol style="list-style-type: none"> 1. Equipment malfunction 			

2. Holiday in coating

Electric Actuator/Operator Inspection and Testing, Preventive and Corrective Maintenance		Task #	0361
Task Guidance	This task includes verification that the actuator/operator is functioning within specified parameters, after installation, and prior to or during placing in service. This task also includes the repair, replacement, alteration or refurbishment of actuator/operator, and actions to keep actuator/operator operating safely and efficiently.		
Task Specific AOC's			
1. Equipment malfunction			

Emergency Response		Task #	A003
Task Guidance	This task includes the necessary guidance to insure the safety of the Public, Gas Customers and Company Employees during Natural Gas Emergencies.		
Task Specific AOC's			
<ol style="list-style-type: none"> 1. Hazardous Gas Concentration Indoors, Outdoors or in Sanitary Sewers 2. Major Leaks or Line Breaks 3. Fire, Ignition or Explosion - Gas Related 4. Explosion / Fire near Gas Pipeline Facilities 5. High Pressure Situation 			

Explosive Atmosphere Detection and Alarm System Performance Test, and Corrective Maintenance		Task #	0551
Task Guidance	This task includes verification that the permanently installed explosive atmosphere detection and alarm system is functioning within specified parameters, after installation, and prior to or during placing in service. This task also includes the performance test, and the repair or replacement of fixed explosive atmosphere detection and alarm system.		

Task Specific AOC's
<ol style="list-style-type: none"> 1. Explosive atmosphere detected 2. Equipment malfunction

External Coating Application and Repair - Wrapped		Task #	1011
Task Guidance	This task includes the surface preparation and application or repair of coatings using cold wrap or wax wrap. This task includes the surface preparation and application or repair of coatings using hot wrap.		
Task Specific AOC's			
<ol style="list-style-type: none"> 1. Damage to existing wrap/coating 2. Improper pipe surface preparation 3. Improper installation of wrap 			

Field Bending of Steel Pipe		Task #	0891
Task Guidance	This task includes the field bending of steel pipe as specified and inspection of completed field bends.		
Task Specific AOC's			
<ol style="list-style-type: none"> 1. Damaged or kinked pipe 2. Damaged coating 3. Bend beyond minimum allowed radius 			

Fit-Up Weld Type Repair Sleeve		Task #	1051
Task Guidance	This task includes the preparation and fit-up of weld type repair sleeves.		

Task Specific AOC's
<ol style="list-style-type: none"> 1. Improper selection of material on sleeve. 2. Incorrect electrode selection. 3. Improper cleanliness of pipe. 4. Failure to UT pipe for wall thickness.

Hydraulic Actuator/Operator Inspection and Testing, Preventive and Corrective Maintenance		Task #	0371
Task Guidance	This task includes verification that the actuator/operator is functioning within specified parameters, after installation and prior to or during placing service. This includes the repair, replacement, alteration or refurbishment of the actuator/ operator and actions to keep the actuator/operator operating safely and efficiently.		
Task Specific AOC's			
<ol style="list-style-type: none"> 1. Equipment malfunction 			

Insert and Remove Coupons/Probes for Internal Corrosion Monitoring		Task #	0131
Task Guidance	This task includes inserting and removing coupons/probes for internal corrosion monitoring and preventing contamination or damage of the coupons/probes		
Task Specific AOC's			
<ol style="list-style-type: none"> 1. Missing coupon 2. Damage to coupon holder 3. Gas leak 4. Internal Corrosion 			

Inside Gas Leak Investigation	Task #	1231
-------------------------------	--------	------

<p>Task Guidance</p>	<p>This task includes the investigation of reported or discovered leaks inside a building in relation to emergency response. This also includes initiation of precautionary actions (make safe). Repairing and proving the integrity of customer piping and lighting customer utilization equipment is not included.</p>
<p>Task Specific AOC's</p>	
<ol style="list-style-type: none"> 1. Gas leak 2. Gas concentrations 10% LEL or more 3. Gas related fire or explosion 4. Damaged distribution facilities 5. Material defects on distribution facilities 6. Equipment malfunction on distribution facilities 	

<p>Inspect and Maintain a Pipeline Heater</p>		<p>Task #</p>	<p>1671</p>
<p>Task Guidance</p>	<p>This task includes verification that the pipeline heater is functioning within specified parameters. This task also includes actions to keep the pipeline heater operating safely and efficiently. This task does not include inspecting, testing, and maintaining pressure-regulating and pressure-relief devices as addressed in:</p> <ol style="list-style-type: none"> 1. Task 0381, Inspect, Test, and Maintain Spring-Loaded, Pressure-Regulating Device. 2. Task 0411, Inspect, Test, and Maintain Spring-Loaded, Pressure-Limiting of Pressure-Relief Device. 		
<p>Task Specific AOC's</p>			
<ol style="list-style-type: none"> 1. Corrosion 2. Glycol Leakage 3. Inoperable Safety Equipment 4. Poor Burner Operation / Improper Temperature 5. Re-lighter Failure 			

Inspect and Monitor Galvanic Ground Beds/Anodes		Task #	0031
Task Guidance	This task includes inspecting and monitoring the electrical potential of galvanic ground beds/anodes		
Task Specific AOC's			
<ol style="list-style-type: none"> 1. Broken wire 2. Dry soil 3. Depleted anodes 			

Inspect or Test Cathodic Protection Bonds		Task #	0061
Task Guidance	This task includes inspecting the physical integrity and testing of cathodic protection bonds		
Task Specific AOC's			
<ol style="list-style-type: none"> 1. Broken bond 2. Damaged Components 3. Stray Current 			

Inspect or Test Cathodic Protection Electrical Isolation Devices		Task #	0071
Task Guidance	This task includes inspecting the physical integrity and testing electrical isolation devices.		
Task Specific AOC's			
<ol style="list-style-type: none"> 1. Deteriorated isolation device 2. Device does not provide electrical isolation 3. Gas leak 			

Inspect Pipeline Surface Conditions - Patrol Right of Way or Easement		Task #	1311
Task Guidance	This task includes performing right-of-way or easement patrol (e.g., walking, flying or driving) to visually identify signs of leaks, encroachments, conditions of the right of way, or any other signs of potential impact to pipeline safety or integrity. This includes reporting an emergency condition.		
Task Specific AOC's			
<ol style="list-style-type: none"> 1. Encroachments 2. Potential dangers to pipeline 3. Poor condition or access to right of way 4. Damage to facilities 5. Gas Leaks 			

Inspect Rectifier and Obtain Readings		Task #	0101
Task Guidance	This task includes inspecting the rectifier for damage and deterioration and obtaining readings as specified.		
Task Specific AOC's			
<ol style="list-style-type: none"> 1. Equipment failure 2. Damage to Rectifier 3. Debris inside cabinet 4. AC Voltage detected on Rectifier case 			

Inspect, Test and Maintain Liquid Knockout (Dehydration) System		Task #	1681
Task Guidance	This task includes verification that the liquid knockout system is functioning within specified parameters after installation and prior to or during placement in service. This task also includes actions to keep the system operating safely and efficiently.		
Task Specific AOC's			

1. Improper dump valve level controller operation
2. Pressure relief valve relieving on vessel
3. Dump valve leaking by to liquid storage tank system

Inspect, Test and Maintain Glycol Dehydration System		Task #	1691
Task Guidance	This task includes verification that the glycol dehydration system is functioning within specified parameters after installation and prior to or during placement in service. This task also includes the repair or replacement, alteration, or refurbishment of the dehydration system and actions to keep the system operating safely and efficiently.		
Task Specific AOC's			
<ol style="list-style-type: none"> 1. Glycol Pump failure 2. Leaks anywhere on the system 3. High or low glycol temperature in the re-boiler section of the regenerator unit 			

Inspect, Test and Maintain Mole Sieve Dehydration System		Task #	1701
Task Guidance	This task includes verification that the mole sieve (dry-bed) dehydration system is functioning within specified parameters after installation and prior to or during placement in service. This task also includes the repair or replacement, alteration, or refurbishment of the dehydration system and actions to keep the system operating safely and efficiently.		
Task Specific AOC's			
<ol style="list-style-type: none"> 1. High or low gas temperatures 2. Gas valve misalignment 3. No or low gas flow through the system on regeneration process 			

Inspect, Test and Maintain Programmable Logic Controllers		Task #	0231
--	--	---------------	-------------

Task Guidance	This task includes verification that the PLC is functioning within specified parameters, after a PLC has been installed, and prior to or during placing in service. This task also includes actions to repair or replace PLCs and components, and adjusting set points or output as specified.
Task Specific AOC's	
<ol style="list-style-type: none"> 1. No power to unit 2. Incorrect Calibration 3. Loss of Communication 	

Inspect, Test and Maintain Sensing Devices		Task #	0221
Task Guidance	This task includes verification that the sensing device is functioning within in specified parameters, after a sensing device has been installed and prior to or during placing in service. This task also includes action to repair or replace sensing devices and adjust set points or output.		
Task Specific AOC's			
<ol style="list-style-type: none"> 1. Incorrect calibration 2. Equipment malfunction 3. Power interruption 			

Inspect Water Crossing		Task #	1285
Task Guidance	This task includes using visual inspection by divers, and/or instrumented detection equipment (sonar, probing, etc.) to inspect underwater pipeline facilities and crossing conditions. This task does not include the items addressed in Task 1481, Diving: Perform Temporary Marking of Underwater Pipeline.		
Task Specific AOC's			
<ol style="list-style-type: none"> 1. Missing or damage markers 2. Missing or outdated warning sticker on marker 			

3. Gas leak

Install and Maintain Pipeline Markers		Task #	1301
Task Guidance	This task includes determining the location, placing and maintaining permanent pipeline markers.		
Task Specific AOC's			
<ol style="list-style-type: none"> 1. Missing or damage of markers 2. Missing or outdated warning sticker on marker 			

Install Cathodic Protection Electrical Isolation Devices		Task #	0081
Task Guidance	This task includes the installation of electrical isolation devices.		
Task Specific AOC's			
<ol style="list-style-type: none"> 1. Device does not provide electrical isolation 2. Gas leak 			

Install Composite Sleeve		Task #	1061
Task Guidance	This task includes preparation and installation and of composite sleeves.		
Task Specific AOC's			
<ol style="list-style-type: none"> 1. Improper surface preparation 2. Improper sleeve installation 3. Gas leak 			

Install Mechanical Clamps and Sleeves - Bolted		Task #	1041
---	--	---------------	-------------

Task Guidance	This task includes the preparation, installation and inspection of bolted mechanical clamps and sleeves.
Task Specific AOC's	
<ol style="list-style-type: none"> 1. Equipment malfunction 2. Gas leak 	

Install Tracer Wire		Task #	0941
Task Guidance	This task includes the installation of a tracer wire with plastic pipe including verification of continuity. Electrical connections are addressed in: ASME 0041 - Installation and Maintenance of Mechanical Electrical Connections; and ASME 0051 - Installation of Exothermic Electrical Connections.		
Task Specific AOC's			
<ol style="list-style-type: none"> 1. Damaged wire 2. Damaged wire insulation 3. Wire lacks electrical continuity 			

Installation and Maintenance of Casing Spacers, Vents and Seals		Task #	0971
Task Guidance	This task includes the installation of casing spacers, vents and seals. This task also includes the evaluation, repair or replacement, of casing vents and seals.		
Task Specific AOC's			
<ol style="list-style-type: none"> 1. Pipe insulator failure 2. Blocked casing vent 3. Missing or incorrect signage 4. Gas leak 			

Installation and Maintenance of Mechanical Electrical Connections		Task #	0041
Task Guidance	This task includes making the mechanical connections and repair of tracer wire, test leads, bonds, shunts, etc.		
Task Specific AOC's			
<ol style="list-style-type: none"> 1. Damaged or broken wire 2. Loose connection 3. Corroded connectors 			

Installation of Customer Meters and Regulators - Residential and Small Commercial		Task #	1161
Task Guidance	This task includes locating, and hanging/setting the meter. Attaching a meter bracket does not require qualification as long as a qualified individual completes the installation in accordance with the steps in this task. Proving the integrity of customer piping and lighting customer utilization equipment is not included. The removal and replacement of a meter is a job made up of at least this task and ASME 1201 - Temporary Isolation of Service Lines and Service Discontinuance. As such, a covered task has not been identified for the removal and replacement of residential and small commercial meters and regulators.		
Task Specific AOC's			
<ol style="list-style-type: none"> 1. Improper location 2. Damaged meter 3. Pressure variances 4. Regulator does not lock-up. 5. Improperly supported piping & components 6. Gas leak 			

Installation of Exothermic Electrical Connections		Task #	0051
--	--	---------------	-------------

Task Guidance	This task includes making exothermic (e.g., thermit, cadweld and pin-brazing) connections of tracer wire, test leads, bonds, shunts, etc.
Task Specific AOC's	
<ol style="list-style-type: none"> 1. Hazardous environment/ ignition source 2. Possible damage to pipe 3. Loose connection 4. Gas leak 	

Installation of Pipe Above Ground		Task #	0951
Task Guidance	This task includes the handling and installation of pipe above ground for Transmission, Main, Service and Hazardous Liquid Pipelines to prevent damage.		
Task Specific AOC's			
<ol style="list-style-type: none"> 1. Improper pipe support 2. Gas leak 			

Installation of Plastic Pipe in a Bore		Task #	0911
Task Guidance	After boring is completed, this task includes the handling, pulling in and inspection of exposed pipe. The installation of a tracer wire is addressed in ASME 0941 - Install Tracer Wire.		
Task Specific AOC's			
<ol style="list-style-type: none"> 1. Material defect 2. Damage to pipe 3. Improper burial depth 4. Damaged tracer wire 5. Stress on Pipe 			

Installation of Plastic Pipe in a Ditch		Task #	0901
Task Guidance	After excavation is completed, this task includes the handling, lowering in, and fitting of plastic pipe in a ditch to prevent damage and to assure firm support under and around pipe. The installation of a tracer wire is addressed in ASME 0941 - Install Tracer Wire. This task does not include material inspections as addressed in ASME 0641 - Visually Inspect Pipe and Components Prior to Installation.		
Task Specific AOC's			
<ol style="list-style-type: none"> 1. Material defect 2. Damage to pipe 3. Improper burial depth 4. Stress on pipe 			

Installation of Plastic Pipe in Plowing/Planting		Task #	0931
Task Guidance	This task includes the handling, plowing/planting of plastic pipe, and inspection of exposed pipe. The installation of a tracer wire is addressed in ASME 0941 - Install Tracer Wire.		
Task Specific AOC's			
<ol style="list-style-type: none"> 1. Material defect 2. Damage to pipe 3. Improper burial depth 4. Damaged tracer wire 5. Stress on pipe 			

Installation of Plastic Pipe in Plowing/Pull-In		Task #	0921
--	--	---------------	-------------

Task Guidance	This task includes the handling, plowing/pull-in of plastic pipe, and inspection of exposed pipe. The installation of a tracer wire is addressed in ASME 0941 - Install Tracer Wire.
Task Specific AOC's	
<ol style="list-style-type: none"> 1. Material defect 2. Damage to pipe 3. Improper burial depth 4. Damaged tracer wire 5. Stress on pipe 	

Installation of Steel Pipe in a Bore		Task #	0871
Task Guidance	After boring is completed, this task includes the handling, pulling in and inspection of exposed pipe and coating for Transmission, Main, Service and Hazardous Liquid Pipelines to prevent damage. This task does not include material inspections as addressed in ASME 0641 - Visually Inspect Pipe and Components Prior to Installation.		
Task Specific AOC's			
<ol style="list-style-type: none"> 1. Damage to pipe 2. Damage to coating 3. Improper burial depth 4. Stress on pipe 			

Installation of Steel Pipe in a Ditch		Task #	0861
Task Guidance	After excavation is completed, this task includes the handling, lowering in, and fitting of steel pipe to a ditch for Transmission, Main, Service and Hazardous Liquid Pipelines, to prevent damage and to assure firm support under and around pipe.		
Task Specific AOC's			

<ol style="list-style-type: none"> 1. Stress on pipe 2. Improper burial depth 3. Damage to pipe 4. Damage to coating
--

Installation of Steel Pipe Plowing/Pull-In		Task #	0881
Task Guidance	This task includes the handling, plowing/pull-in of steel pipe, and inspection of exposed pipe and coating for Transmission, Main, Service and Hazardous Liquid Pipelines to prevent damage. This task does not include material inspections as addressed in ASME 0641 - Visually Inspect Pipe and Components Prior to Installation.		
Task Specific AOC's			
<ol style="list-style-type: none"> 1. Damage to pipe 2. Damage to coating 3. Improper burial depth 4. Stress on pipe 			

Installing and Maintaining Customer Pressure Regulating, Limiting, and Relief Device - Large Commercial and Industrial		Task #	1181
Task Guidance	This task includes installing and maintaining pressure regulating, limiting, and relief device. It also includes locating vent and installation of vent piping.		
Task Specific AOC's			
<ol style="list-style-type: none"> 1. Gas leak 2. Pressure variances 3. Regulator will not lock up 4. Lacks proper support 			

Installing Customer Meters - Large Commercial and Industrial		Task #	1171
Task Guidance	<p>This task includes locating, and hanging/setting the meter. Attaching a meter bracket/support does not require qualification as long as a qualified individual completes the installation in accordance with the steps in this task. Proving the integrity of customer piping and lighting customer utilization equipment is not included. The removal and replacement of a meter is a job made up of at least this task and ASME 1201 - Temporary Isolation of Service Lines and Service Discontinuance. As such a covered task has not been identified for the removal and replacement of large commercial and industrial meters and regulators.</p>		
Task Specific AOC's			
<ol style="list-style-type: none"> 1. Improper location 2. Damaged meter 3. Pressure variances 4. Regulator does not lock-up 5. Unsupported piping & components 6. Gas leak 			

Joining of Pipe - Flange Assembly		Task #	0731
Task Guidance	<p>This task includes the assembly of flanges, bolting in sequence and torque, as specified.</p>		
Task Specific AOC's			
<ol style="list-style-type: none"> 1. Damaged pipe or components 2. Gas leak 3. Improper flange rating for pressure application 			

Joining of Pipe - Non-Bottom Out Compression Couplings		Task #	0691
---	--	---------------	-------------

Task Guidance	<p>This task includes the joining of pipe 2 in. (50 mm) and less, with nonbottom-out compression couplings and inspection of completed joints. A nonbottom-out compression coupling is one that requires tightening to a specified torque or number of turns.</p>
Task Specific AOC's	
<ol style="list-style-type: none"> 1. Improper installation 2. Gas leak 	

Joining of Pipe - Threaded Joints		Task #	0721
Task Guidance	<p>This task includes the joining of threaded pipe with threaded fittings, and the inspection of completed joints. The joining of components with threaded connections is addressed in the component covered task.</p>		
Task Specific AOC's			
<ol style="list-style-type: none"> 1. Damaged pipe or components 2. Gas leak 3. Improper Joint Compound 			

Joining of Plastic Pipe - Bottom Out Compression Coupling		Task #	0701
Task Guidance	<p>This task includes the joining of pipe 2 inch and less with bottom out compression couplings and inspection of completed joints. A bottom out compression coupling is one that is designed to prevent over tightening by contact (bottoming out) of the nut with a square shoulder or mating surface.</p>		
Task Specific AOC's			
<ol style="list-style-type: none"> 1. Improper installation 2. Gas leak 3. Not bottoming out 			

Joining of Plastic Pipe - Butt Heat Fusion: Hydraulic Machine		Task #	0761
Task Guidance	This task include the assembly and joining of plastic pipe by butt heat fusion using a hydraulic machine and inspection of completed joints.		
Task Specific AOC's			
<ol style="list-style-type: none"> 1. Misaligned pipe 2. Unacceptable melt /joint 3. Contaminated pipe 			

Joining of Plastic Pipe - Butt Heat Fusion: Manual		Task #	0751
Task Guidance	This task includes the assembly and joining of plastic pipe by butt fusion and inspection of completed joints.		
Task Specific AOC's			
<ol style="list-style-type: none"> 1. Pipe contaminated 2. Unacceptable melt / joint 3. Pipe misaligned 			

Joining of Plastic Pipe - Electrofusion		Task #	0781
Task Guidance	This task includes the assembly and joining of plastic pipe by electrofusion and inspection of completed joints.		
Task Specific AOC's			
<ol style="list-style-type: none"> 1. Contaminated pipe or fitting 2. Not scrapped properly 3. Fitting not centered 			

<ol style="list-style-type: none"> 4. Error code on box 5. Equipment malfunction
--

Joining of Plastic Pipe - Stab Fittings		Task #	0681
Task Guidance	This task includes the joining and inspection of plastic pipe with stab fittings and inspection of completed joints.		
Task Specific AOC's			
<ol style="list-style-type: none"> 1. Improper stab depth 2. Gas leak 			

Launching and or Receiving Internal Devices (Pigs) for Lines In-Service		Task #	1641
Task Guidance	This task consist of isolating pipeline barrels, relieving pressure, inserting or removing internal devices (pigs), pressurizing barrel, and launching/receiving internal devices (pigs).		
Task Specific AOC's			
<ol style="list-style-type: none"> 1. Improperly sized device (pig) 2. Exceeding MAOP 3. Improper valve sequence 4. Device (pig) signal failure 5. Stuck device (pig) 			

Launching and or Receiving Internal Devices (Pigs) with a Temporary Launcher or Receiver for Lines Out of Service		Task #	1631
Task Guidance	This task consist of inserting or removing internal devices (pigs) on pipeline systems not in service.		
Task Specific AOC's			

1. Improperly sized device (pig)
2. Exceeding MAOP
3. Improper valve sequence
4. Device (pig) signal failure
5. Stuck device (pig)

Leak Test at Operating Pressure		Task #	0591
Task Guidance	This task includes the detection of leaks at operating pressure with leak detection fluid.		
Task Specific AOC's			
<ol style="list-style-type: none"> 1. Leak test failure/ Gas leak 2. Equipment malfunction 			

Locate Underground Pipelines		Task #	1291
Task Guidance	This task includes locating underground pipelines utilizing maps, records, and locating equipment. It also includes placing temporary markers or markings.		
Task Specific AOC's			
<ol style="list-style-type: none"> 1. Equipment malfunction 2. Facilities difficult to locate 3. False signals 			

Maintain Rectifier		Task #	0111
Task Guidance	This task includes verification that the rectifier is functioning within specified parameters, after a rectifier has been hung and AC power connected, and prior to or during placing in service. This task		

	also includes actions to repair or replace in service rectifiers or components.
Task Specific AOC's	
<ol style="list-style-type: none"> 1. Equipment failure 2. Damage to Rectifier 3. Debris inside cabinet 4. AC Voltage detected on Rectifier case 	

Maintenance of Service Valves Upstream of Customer Meter		Task #	1191
Task Guidance	This task includes removing, replacing and maintaining service valves upstream of customer meter.		
Task Specific AOC's			
<ol style="list-style-type: none"> 1. Damaged component 2. Valve does not operate 3. Valve is not accessible (buried) 4. Gas leak 			

Manually Opening and Closing Valves		Task #	0301
Task Guidance	This task includes manually opening and closing valves, (e.g., pipeline start up and shutdown, flow direction, pigging, tank switching, etc.), at the valve site, either manually or using the valve actuator. It also includes valve identification, notifications and pressure verification.		
Task Specific AOC's			
<ol style="list-style-type: none"> 1. Inoperable valve 2. Damage to facilities 3. Pressure deviation 			

<ol style="list-style-type: none"> 4. Gas leak 5. Interruption of service

Measure and Characterize Mechanical Damage on Installed Pipe and Components		Task #	0211
Task Guidance	This task includes activities to measure and characterize mechanical damage (e.g., dents, gouges, cracks) on installed pipe and components, including investigation to determine the extent of damage and recording data.		
Task Specific AOC's			
<ol style="list-style-type: none"> 1. Damaged coating 2. Damage to pipe or component 3. Gas leak 4. Interruption of service 5. Pressure variances 			

Measure Atmospheric Corrosion		Task #	0191
Task Guidance	This task includes activities to measure and characterize atmospheric corrosion, including investigation to determine the extent of corrosion and recording data.		
Task Specific AOC's			
<ol style="list-style-type: none"> 1. Pit depth exceeds limits 2. Gas leak 			

Measure External Corrosion		Task #	0171
Task Guidance	This task includes activities to measure and characterize external corrosion, including investigation to determine the extent of corrosion and recording data.		

Task Specific AOC's	
<ol style="list-style-type: none"> 1. Pit depth exceeds limits 2. Gas leak 	

Measure Internal Corrosion		Task #	0181
Task Guidance	This task includes activities to measure and characterize internal corrosion, including investigation to determine the extent of corrosion and recording data.		
Task Specific AOC's			
<ol style="list-style-type: none"> 1. Foreign substance in pipe 2. Pit depth exceeds limits 3. Gas leak 			

Measure Soil Resistivity		Task #	0021
Task Guidance	This task includes using measurement equipment to measure soil resistivity and recording data		
Task Specific AOC's			
<ol style="list-style-type: none"> 1. Poor soil conditions 2. Buried metallic structures in the area 3. Incorrect resistivity calculations 4. Defective equipment 5. Inaccurate locates 			

Measure Structure-to-Electrolyte Potential		Task #	0001
---	--	---------------	-------------

Task Guidance	This task includes using measurement equipment to take a reading of the potential between the structure (pipe, tanks, etc.) being tested and the soil and recording data.
Task Specific AOC's	
<ol style="list-style-type: none"> 1. AC Voltage on Structure 2. Deficient P/S reading 3. Unfavorable soil surface conditions 4. Damaged test station 	

Mobile Gas Leakage Survey: Flame Ionization		Task #	1271
Task Guidance	This task includes conducting a mobile (other than walking) gas leakage survey utilizing leak-detection survey equipment (e.g., flame ionization, optical methane, and laser), documentation, and reporting a condition.		
Task Specific AOC's			
<ol style="list-style-type: none"> 1. Gas Leak 2. Equipment malfunction 3. Damaged facilities 4. Unfavorable weather conditions 			

Mobile Gas Leakage Survey: Laser Spectroscopy		Task #	A004
Task Guidance	This task includes conducting a mobile (other than walking) gas leak survey utilizing Laser Spectroscopy (Advanced Mobile Leak Detection) survey equipment, documentation and reporting an emergency condition.		
Task Specific AOC's			
<ol style="list-style-type: none"> 1. Gas Leak 2. Equipment malfunction 			

- 3. Unfavorable weather conditions
- 4. Damaged Facilities

Mobile Gas Leakage Survey - Optical Methane		Task #	1281
Task Guidance	This task includes conducting a mobile (other than walking) gas leak survey utilizing optical methane detection survey equipment, documentation and reporting an emergency condition.		
Task Specific AOC's			
<ul style="list-style-type: none"> 1. Gas Leak 2. Equipment malfunction 3. Unfavorable weather conditions. 4. Damaged Facilities 			

NDT - Liquid Penetrate Testing		Task #	0611
Task Guidance	This task includes liquid dye penetrate testing and evaluation of test results.		
Task Specific AOC's			
<ul style="list-style-type: none"> 1. Pipe or component contamination 2. Deterioration or material defect 			

NDT - Magnetic Particle Testing		Task #	0621
Task Guidance	This task includes magnetic particle testing and evaluation of test results.		
Task Specific AOC's			
<ul style="list-style-type: none"> 1. Pipe or component contamination 			

2. Deterioration or material defect

NDT Radiographic Testing		Task #	0601
Task Guidance	This task includes radiographic testing and evaluation of testing results.		
Task Specific AOC's			
<ol style="list-style-type: none"> 1. Pipe or component contamination 2. Deterioration or material defect 			

NDT - Ultrasonic Testing		Task #	0631
Task Guidance	This task includes ultrasonic testing and evaluation of test results. This task excludes wall thickness determination with a UT wall thickness device.		
Task Specific AOC's			
<ol style="list-style-type: none"> 1. Pipe or component contamination 2. Deterioration or material defect 			

Odorization - Odorizer Inspection, Testing, Preventive and Corrective Maintenance		Task #	1221
Task Guidance	This task includes verification that the odorizer is functioning within specified parameters after installation or replacement and prior to or during placing in service. This task includes the repair, replacement, alteration or refurbishment of the odorizer and actions to keep the odorizer operating safely and efficiently.		
Task Specific AOC's			
<ol style="list-style-type: none"> 1. Over or Under Odorization 2. Gas leak 			

<ol style="list-style-type: none"> 3. Equipment malfunction 4. Odorant leak / spill

Odorization - Periodic Sampling		Task #	1211
Task Guidance	This task includes the periodic sampling of gas to verify concentration of odorant by use of instrumentation or verification of presence of odor by sniff test.		
Task Specific AOC's			
<ol style="list-style-type: none"> 1. Odorization level too low 2. Gas leak 3. Equipment malfunction 			

Operate Gas Pipeline – System Control Center Operations		Task #	1371
Task Guidance	This task includes the remote control operations of a gas pipeline (e.g., monitor operating parameters, notifications, remotely adjusting and maintaining pressure, remotely starting and stopping compressors, etc.)..		
Task Specific AOC's			
<ol style="list-style-type: none"> 1. Overpressure situation 2. Under pressure situation 			

Operate Gas Pipeline - Local Facility Remote-Control Operations		Task #	1381
Task Guidance	This task includes the local facility remote control operations of a gas pipeline (e.g., monitor operating parameters, notifications, remotely adjusting and maintaining pressure, remotely starting and stopping compressors, etc.).		
Task Specific AOC's			

1. Overpressure situation
2. Under pressure situation

Outside Gas Leak Investigation		Task #	1241
Task Guidance	This task includes the investigation of reported or discovered outside leaks of the operators' lines. Task also includes initiation of precautionary actions (make safe).		
Task Specific AOC's			
<ol style="list-style-type: none"> 1. Gas related fire or explosion 2. Blowing gas 3. Hazardous Environment 4. Damaged components 5. Material defect 6. Equipment malfunction 			

Perform Electrical inspection of Pipe Coating (Holiday Detection or Jeeping)		Task #	1020
Task Guidance	This task includes the electrical inspection of pipe coating (i.e., holiday detection, jeeping)		
Task Specific AOC's			
<ol style="list-style-type: none"> 1. Equipment malfunction 2. Holiday in coating 			

Pilot Operated Pressure Regulating Device - Inspection and Testing, Preventative and Corrective Maintenance		Task #	0391
Task Guidance	This task includes verification that the pressure-regulating device is functioning within specified parameters after installation and prior to or during placing in service. This includes repair or replacement, alteration or refurbishment of the pressure-regulating de-		

	vice and actions to keep the pressure-regulating device operating safely and efficiently.
Task Specific AOC's	
<ol style="list-style-type: none"> 1. Pressure Above or Below expected value 2. Pressure exceeding MAOP 3. Failure to lock up 4. Gas leak 	

Pilot-Operated Pressure Limiting and Relief Device - Inspection and Testing, Preventative and Corrective Maintenance		Task #	0421
Task Guidance	This task includes verification that the pressure limiting or relief device is functioning within specified parameters, after installation, and prior to or during placing in service. This task also includes the repair or replacement, alteration or refurbishment of pressure limiting or relief device, and actions to keep the pressure limiting or relief device operating safely and efficiently.		
Task Specific AOC's			
<ol style="list-style-type: none"> 1. Pressure Above or Below expected value 2. Pressure Exceeding MAOP 3. Failure to reseal 4. Gas leak 			

Pneumatic Actuator/Operator Inspection and Testing, Preventative and Corrective Maintenance		Task #	0351
Task Guidance	This task includes verification that the actuator/operator is functioning within specified parameters, after installation, and prior to or during placing in service. This task also includes the repair, replacement, alteration or refurbishment of actuator/operator, and actions to keep actuator/operator operating safely and efficiently.		
Task Specific AOC's			
<ol style="list-style-type: none"> 1. Equipment malfunction 			

2. Gas Leak

Pneumatic Loaded Pressure Limiting and Relief Device - Inspection and Testing, Preventative and Corrective Maintenance		Task #	0431
Task Guidance	This task includes verification that the pressure limiting or relief device is functioning within specified parameters, after installation, and prior to or during placing in service. This task also includes the repair or replacement, alteration or refurbishment of pressure limiting or relief device, and actions to keep the pressure limiting or relief device operating safely and efficiently. (Pressure or Flow Controllers)		
Task Specific AOC's			
<ol style="list-style-type: none"> 1. Pressure Above or Below expected value 2. Pressure exceeding MAOP 3. Gas leak 			

Pressure Test - Liquid Medium		Task #	0581
Task Guidance	This task includes achieving test pressure and durations, and record keeping.		
Task Specific AOC's			
<ol style="list-style-type: none"> 1. Pressure test failure 2. Equipment failure 3. Excessive water left in pipe 			

Pressure Test - Non-liquid Medium - MAOP Greater Than or Equal to 100 Psi		Task #	0571
Task Guidance	This task includes achieving test pressure and durations, and record keeping.		

Task Specific AOC's	
<ol style="list-style-type: none"> 1. Pressure test failure 2. Equipment failure 	

Pressure Test - Non-liquid Medium - MAOP Less Than 100 Psi		Task #	0561
Task Guidance	This task includes achieving test pressure and durations, and record keeping.		
Task Specific AOC's			
<ol style="list-style-type: none"> 1. Pressure test failure 2. Equipment failure 			

Provide or Assure Adequate Pipeline Support During Operator Initiated Excavation Activities		Task #	1341
Task Guidance	This task includes the actions necessary to provide or assure adequate pipeline support during excavation activities (e.g., installing bridging, bracing, etc.).		
Task Specific AOC's			
<ol style="list-style-type: none"> 1. Damage to pipeline 2. Pipeline not properly supported 3. Gas leak 			

Purge- Flammable or Inert Gas		Task #	1651
Task Guidance	This task includes actions to be taken to safely purge pipeline facilities using natural gas, inert gas or air.		
Task Specific AOC's			

1. Hazardous gas/air mixture
2. Isolated sections not purged
3. Gas Ignition
4. Unplanned loss of service

Reciprocating Compressor Inspection, Testing and Corrective Maintenance		Task #	0471
Task Guidance	This task includes verification that a new, replaced, or rebuilt compressor is functioning within specified parameters, prior to or during placing in service. This task includes the repair, alteration or refurbishment of compressors. This task does not include maintenance of the compressor driver.		
Task Specific AOC's			
<ol style="list-style-type: none"> 1. Equipment malfunction 2. Gas leak 			

Repair of Steel Pipe by Grinding		Task #	1071
Task Guidance	This task includes the verification of minimal wall thickness requirements and removal of defects by grinding.		
Task Specific AOC's			
<ol style="list-style-type: none"> 1. Excessive removal of wall. 2. Too aggressive of sanding pad on buffing wheel. 3. Inadequate grinding/buff. 			

Rotary Compressor Inspection, Testing and Corrective Maintenance		Task #	0491
Task Guidance	This task includes verification that a new, replaced, or rebuilt compressor is functioning within specified parameters, prior to or during placing in service. This task includes the repair, alteration or		

UNCONTROLLED IF PRINTED

	refurbishment of compressors. This task does not include maintenance of the compressor driver.
Task Specific AOC's	
<ol style="list-style-type: none"> 1. Equipment malfunction 2. Gas leak 	

Service Reconnect		Task #	A001
Task Guidance	This task includes reinstatement of gas service to customer equipment. This task may include inspection and relighting customer equipment.		
Task Specific AOC's			
<ol style="list-style-type: none"> 1. Gas leak 2. Damage to components 3. Codes/hazards with customer facilities 4. Faulty equipment 5. Failed appliance safety 6. Meter does not register flow 			

Spring Loaded Pressure Regulating Device - Inspection and Testing, Preventive and Corrective Maintenance		Task #	0381
Task Guidance	This task includes verification that the pressure regulating device is functioning within specified parameters, after installation, and prior to or during placing in service. This task also includes the repair or replacement, alteration or refurbishment of pressure regulating device, and actions to keep the pressure regulating device operating safely and efficiently.		
Task Specific AOC's			
<ol style="list-style-type: none"> 1. Regulator does not lock up 2. Pressure deviation 			

- | |
|---|
| <ol style="list-style-type: none"> 3. Missing vent screen / adjustment cap 4. Vent improperly oriented 5. Gas leak |
|---|

Spring-Loaded Pressure Limiting and Relief Device - Inspection, Testing, Preventive and Corrective Maintenance		Task #	0411
Task Guidance	This task includes verification that the pressure limiting or relief device is functioning within specified parameters, after installation, and prior to or during placing in service. This task also includes the repair or replacement, alteration or refurbishment of pressure limiting or relief device, and actions to keep the pressure limiting or relief device operating safely and efficiently.		
Task Specific AOC's			
<ol style="list-style-type: none"> 1. Relief valve will not open 2. Relief valve will not reseal 3. Over-pressurization 4. Gas leak 			

Squeeze Off Plastic Pipe		Task #	1141
Task Guidance	This task includes the squeeze off of plastic pipe. This also includes the selection, installation and removal of squeeze off tools and monitoring pressure to assure system pressure requirements are maintained.		
Task Specific AOC's			
<ol style="list-style-type: none"> 1. Damage to pipeline 2. Exceeding squeeze down and release rates. 3. Loss of system pressure 4. Gas leak 			

Squeeze Off Steel Pipe		Task #	1151
Task Guidance	This task includes the squeeze off of steel pipe. This also includes the selection, installation and removal of squeeze off tools and monitoring pressure to assure system pressure requirements are maintained.		
Task Specific AOC's			
<ol style="list-style-type: none"> 1. Loss of system pressure 2. Gas leak 			

Station Emergency Shutdown (ESD) system - Inspection, Testing and Corrective Maintenance		Task #	1361
Task Guidance	<p>This task includes verification that the station emergency shutdown system is functioning within specified parameters after installation and prior to or during placing in service</p> <p>This task also includes the repair or replacement, alteration, or refurbishment of the station emergency shutdown system and actions to verify operation and maintain the station emergency shutdown system.</p>		
Task Specific AOC's			
<ol style="list-style-type: none"> 1. Inoperable valves 2. Hazardous environment 3. Pressure deviation 4. Wrong sequence of valves to shut down 			

Stopper (Stopp) Pipe		Task #	1131
Task Guidance	This task includes the insertion and removal of a stopper (stopple). It also includes pressure verification and monitoring pressure to assure system pressure requirements are maintained.		
Task Specific AOC's			

1. Equipment failure
2. Interruption of service
3. Inadequate stop-off
4. Gas leak

Tapping a Pipeline (Tap Diameter 2 Inch or Less)		Task #	1081
Task Guidance	This task includes performing tapping including the installation of the isolation valve and tapping equipment, and removal of isolation valve, as specified. Installation of fittings is addressed in: ASME 0801 - Welding; and ASME 1041 - Install Mechanical Clamps and Sleeves - Bolted.		
Task Specific AOC's			
<ol style="list-style-type: none"> 1. Damage to pipeline 2. Equipment malfunction 3. Release of kinetic energy 4. Interruption of Service 5. Gas leak 			

Tapping a Pipeline (Tap Diameter Greater Than 2 Inch)		Task #	1091
Task Guidance	This task includes performing tapping including the installation of the isolation valve and tapping equipment, and removal of isolation valve, as specified. Installation of fittings is addressed in: ASME 0801 - Welding; and ASME 1041 - Install Mechanical Clamps and Sleeves - Bolted.		
Task Specific AOC's			
<ol style="list-style-type: none"> 1. Damage to pipeline 2. Equipment malfunction 3. Release of kinetic energy 4. Interruption of Service 			

5. Gas leak

Tapping a Pipeline With a Built-In Cutter		Task #	1101
Task Guidance	This task includes tapping a pipe with an installed fitting that contains a built-in cutter. Installation of fittings is addressed in: ASME 0771 - Joining of Plastic Pipe - Sidewall Heat Fusion; ASME 0781 - Joining of Plastic Pipe - Electrofusion; ASME 0801 Welding; and ASME 1041 - Install Mechanical Clamps and Sleeves - Bolted.		
Task Specific AOC's			
<ol style="list-style-type: none"> 1. Material defect 2. Equipment malfunction 3. Damage to pipeline 4. Gas leak 			

Temporary Isolation of Service Lines and Service Discontin- ance		Task #	1201
Task Guidance	This task includes closing and locking service valves upstream of the customer meter or installation of a mechanical device or fitting to prevent the flow of gas.		
Task Specific AOC's			
<ol style="list-style-type: none"> 1. Damaged components 2. Gas leak 			

Troubleshoot in-Service Cathodic Protection System		Task #	0091
Task Guidance	This task applies to operational Cathodic Protection Systems and includes activities to determine why the CP system and components are not functioning and the identification of corrective action.		

Task Specific AOC's
<ol style="list-style-type: none"> 1. Damaged or defective components 2. Corrosion 3. Short on system 4. Stray current 5. Gas leak

Tubing and Fitting Installation - Instrument, Control, and Sampling		Task #	0821
Task Guidance	This task includes the preparation, bending, joining, and installation of instrument, control and sampling line tubing and fittings containing product.		
Task Specific AOC's			
<ol style="list-style-type: none"> 1. Improper Connection 2. Gas Leak 3. Non-compatible Material 			

Valve - Preventive Maintenance		Task #	0341
Task Guidance	This task encompasses actions (e.g., lubrication, winterization, packing adjustment, etc.) to keep valves operating safely and efficiently.		
Task Specific AOC's			
<ol style="list-style-type: none"> 1. Inoperable valve 2. Grease will not penetrate valve 3. Damage to facilities 4. Gas leak 			

Valve - Visual Inspection and Partial Operation		Task #	0331
Task Guidance	This task includes visual inspection, partial operation (function test), and lubrication of valves.		
Task Specific AOC's			
<ol style="list-style-type: none"> 1. Inoperable valve 2. Damaged valve 3. Gas leak 4. Pressure deviation 5. Customer loss 			

Valve Corrective Maintenance		Task #	0321
Task Guidance	This task includes the repair, replacement, alteration or refurbishment of valves.		
Task Specific AOC's			
<ol style="list-style-type: none"> 1. Grease will not penetrate valve 2. Inoperable valve 3. Damaged valve 4. Pressure deviation 5. Gas leak 			

Vault Inspection and Maintenance		Task #	1351
Task Guidance	This task applies to the inspection and maintenance of vaults housing pressure regulating and pressure limiting equipment, having a volumetric internal content of 200 cubic feet or more. It includes inspection of ventilating equipment, vault cover, sufficient drainage and structural integrity. Investigation to identify product leakage is addressed in: ASME 1231 - Inside Gas Leak Investiga-		

	tion; ASME 1241 - Outside Gas Leak Investigation; and ASME 1251 - Hazardous Liquid Leak Investigation.
Task Specific AOC's	
<ol style="list-style-type: none"> 1. Gas leak 2. Structural deterioration of vault 3. Ventilating system not working 4. Insufficient drainage 	

Visual Inspection for Atmospheric Corrosion		Task #	0141
Task Guidance	This task includes the inspection of pipe and pipeline components exposed to the atmosphere for the purpose of detecting atmospheric corrosion.		
Task Specific AOC's			
<ol style="list-style-type: none"> 1. Defective coating 2. Atmospheric corrosion 3. Damage to components 4. Gas leak 			

Visual Inspection for Internal Corrosion		Task #	0161
Task Guidance	This task includes the inspection of the internal surface of pipe and pipeline components, including tapping coupons, when exposed for the purpose of detecting internal corrosion.		
Task Specific AOC's			
<ol style="list-style-type: none"> 1. Internal corrosion 2. Foreign substance in pipe 3. Gas Leak 			

Visual Inspection of Buried Pipe and Components When Exposed		Task #	0151
Task Guidance	This task includes the inspection of buried pipe and pipeline components when exposed for the purpose of detecting external corrosion and evaluating coating integrity.		
Task Specific AOC's			
<ol style="list-style-type: none"> 1. Unsatisfactory coating 2. Corrosion on pipe 3. Damaged components 4. Gas leak 			

Visual Inspection of Installed Pipe and Components for Mechanical Damage		Task #	0201
Task Guidance	This task includes activities associated with the inspection of installed pipe and components for the purpose of detecting mechanical damage (e.g., dents, gouges, cracks).		
Task Specific AOC's			
<ol style="list-style-type: none"> 1. Unsatisfactory coating 2. Damage to pipe or components 3. Gas leak 4. Fire or Explosion 5. Pressure Variances 6. Interruption of service 			

Visual Inspection of Welding and Welds		Task #	0811
Task Guidance	This task includes inspection of the welding process (e.g., equipment set up, material fit-up/alignment, handling of welding materials) inspection of welds to identify visually detectable defects. This task should be performed by a person qualified in accordance with API 1104 or other acceptable standard or practice.		
Task Specific AOC's			

<ol style="list-style-type: none"> 1. Arc strikes 2. Unacceptable weld profile 3. Improper Welding Procedure Specification

Visually Inspect Pipe and Components Prior to Installation		Task #	0641
Task Guidance	This task includes the visual examination of pipe and pipeline components, prior to installation, to identify visually determinable damage and defects.		
Task Specific AOC's			
<ol style="list-style-type: none"> 1. Mechanical damage 2. Material defects 3. Unacceptable Coating 			

Walking Gas Leakage Survey		Task #	1261
Task Guidance	This task includes conducting a walking gas leak survey utilizing gas detection survey equipment, documentation, and reporting an emergency condition.		
Task Specific AOC's			
<ol style="list-style-type: none"> 1. Gas leak 2. Corrosion 3. Damage to facilities 4. Improper Installation 5. Equipment malfunction 			

Welding	Task #	0801
----------------	---------------	-------------

Task Guidance	This task includes the assembly and joining of steel pipelines by welding, and repair of welds, in accordance with welding procedures. This task should be performed by a person qualified in accordance with API 1104 or other acceptable standard or practice.
Task Specific AOC's	
<ol style="list-style-type: none"> 1. Excessive cap height or insufficient fill to form a cap. 2. Unacceptable weld profile. 3. Improper Welding Procedure Specification 	

End of Instructions.

Operator Qualification (OQ) Required?

NO

Appendices

NONE

Attachments

NONE.

Compliance Requirements

49 CFR Part 192, Subpart N – Qualification of Pipeline Personnel
 IL Adm. Code Title 83, Part 520 – Training Programs for Natural Gas System Operating Personnel (General Order 204)

Reference Documents

NONE

Document Rescission

OQAL 2.02 Covered Tasks AOC's, October 1, 2022

Revision Notes

Location of Changes	Summary of Changes
Covered Tasks AOC's	Added - Mobile Gas Leakage Survey – Laser Spectroscopy, Task # A004

Operator Qualification

October 1, 2022

OQAL 4 Forms and Reference Materials

Click on the links below to open the documents.

Forms

1. [Ameren Illinois Contractor Hiring Checklist](#)
2. [OQ Task Disqualification Notice](#) – Updated
3. [OQ Contractor OQ Plan Approval Form](#)

End of Section.

Document Rescission

OQAL 4 Forms and Reference Materials, May 15, 2022

Revision Notes

Location of Changes	Summary of Changes
Entire Document	Format of document has been changed to match the format of October 2022 Issue

PCBH-PCB Handling

PCB Handling

May 15, 2022

PCBH 0 Table of Contents

[PCBH 1 PCB Handling: Requirements](#)

- Section 1.0 Purpose
- Section 2.0 Scope
- Section 3.0 Target Audience
- Section 4.0 General Information
- Section 5.0 Contact Information
- Section 6.0 Testing
- Section 7.0 Disposal
- Reference Documents
- Document Rescission

[PCBH 2.0 PCB Handling: Sampling Liquid from Gas Piping Systems](#)

- Section 1.0 Purpose
- Section 2.0 Scope
- Section 3.0 Target Audience
- Section 4.0 General
- Section 5.0 Equipment
- Section 6.0 Sampling Liquids in Pipeline Facilities
- Section 7.0 Sampling Liquids Contained in Equipment
- Section 8.0 Testing
- Document Rescission
- Revision Notes

[PCBH 2.1 PCB Handling: Positive PCB Detection](#)

- Section 1.0 Purpose
- Section 2.0 Scope
- Section 3.0 Target Audience
- Section 4.0 General Information
- Section 5.0 Positive PCB Detection
- Section 6.0 Non-PCB Detection

UNCONTROLLED IF PRINTED

Section 7.0 Inspection of Customer's Facilities

Document Rescission

Revision Notes

PCBH 2.2 PCB Handling: Staging Area and Disposal Protocol

Section 1.0 Purpose

Section 2.0 Scope

Section 3.0 Target Audience

Section 4.0 General Information

Section 5.0 Positive PCB Detection

Section 6.0 Non-PCB Detection

Section 7.0 Inspection of Customer's Facilities

Document Rescission

Revision Notes

PCBH 2.3 PCB Handling: Liquid Release Protocol

Section 1.0 Purpose

Section 2.0 Scope

Section 3.0 Target Audience

Section 4.0 PPE for Liquid Release Cleanup

Section 5.0 Inside Home Release

Section 6.0 Outside Release

Document Rescission

Revision Notes

PCBH 2.4 PCB Handling: Wipe and Soil Sampling

Section 1.0 Purpose

Section 2.0 Scope

Section 3.0 Target Audience

Section 4.0 General Information

Section 5.0 Wipe Sampling

Section 6.0 Soil Sampling

Document Rescission

Revision Notes

PCBH 3 PCB Handling: Forms and Reference Materials

Forms

End of Table of Contents.

Document Rescission

PCBH 0 PCB Handling: Table of Contents, October 1, 2021.

Revision Notes

Location of Changes	Summary of Changes
Table of Contents	PCBH 2.0 replaces PCBH 2

1.0 Purpose

This document provides general information and contact information that is to be used where oily liquid hydrocarbons are present or suspected to be present in Ameren Illinois (AIC) pipeline facilities, gas storage field facilities or customer owned facilities.

2.0 Scope

This document addresses the following:

[3.0 Target Audience](#)

[4.0 General Information](#)

[5.0 Contact Information](#)

[6.0 Testing](#)

[7.0 Disposal](#)

3.0 Target Audience

- Gas Supervisor
- Gas Field Personnel
- Gas Tech Services (GTS) Supervisor
- Gas Tech Services (GTS) Personnel
- Gas Storage Field Supervisor
- Gas Storage Field Personnel
- Gas Meter Shop Personnel
- IL Safety Supervisor
- Manager Environmental Support & Waste Management

4.0 General Information

- 4.1 Oily liquid hydrocarbons shall be treated as containing more than 49 ppm Polychlorinated Biphenyls (PCBs) until proven otherwise through testing or system knowledge.
- 4.2 PCB sampling equipment is the same as that used by the Electric Department and is available through local Operating Center storerooms or the MDF.
- 4.3 Sample of the oily liquid hydrocarbon should be sent to the Ameren Laboratory Services, 1530 Singleton St., St Louis, MO 63103, phone number 314-554-4257.
- 4.4 PCBs do not readily evaporate so airborne levels are expected to be low so respiratory protection is usually not required.
- 4.5 Prior to performing any inspection or work on gas facilities or meters which contain, or expected to contain, oily liquid hydrocarbons that could be contaminated with PCBs, personnel should be familiar with the information in the **PCB section of the** Ameren Illinois (AIC) Safety Manual.
- 4.6 Primary potential route of exposure is through contact with the skin so the appropriate PPE, rubber or nitrile gloves and coveralls should be worn as necessary.
 - 4.6.1 Wash hands after working with the facilities and before eating or drinking.
 - 4.6.2 Clean tools and equipment after the work

- 4.7 Normal work clothing and PPE can be worn when working with gas equipment or facilities where liquids are totally enclosed and not subject to spillage.
- 4.8 **Personal** Protective Equipment (PPE) can be found through: Co-Worker Connect, Business Segments/Ameren Illinois/IL Safety/PPE & Safety Equipment/PCB Equipment/Pigging and PCB PPE.
- 4.9 A designated Staging area at the Operating Center should be established where collect items can be inspected for **potential** sampling and for disposal **of collected equipment**.

5.0 Contact Information

- 5.1 Gas field personnel, Gas Tech Services (GTS) personnel or gas storage field personnel shall immediately notify their supervisor when:
 - 5.1.1 Oily liquid hydrocarbons could be found in:
 1. AIC gas transmission or distribution mains or service lines.
 2. AIC regulator stations and valve stations
 3. Gas storage field piping and equipmentOr
 4. Customer piping,
 5. Customer gas appliance controls.
- 5.2 Gas Supervisor, GTS Supervisor or Gas Storage Supervisor shall immediately contact their Supervisor who will make the following personnel aware of the situation:
 - 5.2.1 Operations Management,
 - 5.2.2 AIC Safety Supervisor,
 - 5.2.3 Ameren Environmental Support and Waste Management personnel.
 1. Contact information can be found at <https://ameren.sharepoint.com/sites/Environmental/Waste>
- 5.3 Ameren Environmental Support and Waste Management personnel will provide guidance on:
 - 5.3.1 Sampling procedures.
 - 5.3.2 Cleanup procedures.
 - 5.3.3 Necessary PPE.
 - 5.3.4 Need for further inspection.
 - 5.3.5 Disposal process

6.0 Testing

- 6.1 Ameren Laboratory Services will provide information on how samples should be prepared and shipped to the lab for analysis.

Ameren Laboratory Services, 1530 Singleton St., St Louis, MO 63103. Phone number is 314-554-4257

- 6.2 Samples of oily liquid shall be shipped to Ameren Laboratory Services
- 6.3 The Sampling Inspection Form should accompany the samples.
- 6.4 Ameren Laboratory Services will send back the final analysis:
 - 6.4.1 If analysis shows less than 50 ppm, the liquid is considered a Non-PCB waste.
- 6.5 Facilities where test results indicate the oily liquid is PCB contaminated, 50 ppm or greater, Environmental Support and Waste Management may specify additional inspection **requirements**.

7.0 Disposal

- 7.1 The laboratory test analysis will determine the appropriate disposal process.
- 7.2 If the analysis shows 50 ppm or greater, the liquid is PCB contaminated and shall be handled as a PCB **regulated** waste.

Environmental Support and Waste Management shall be notified. They will make the arrangements for pickup and proper disposal of PCB liquid.

- 7.2.1 The PCB contaminated liquid shall be placed in a steel drum and labeled Caution PCB. Liquid would need to be drained from the equipment and placed in drums.
- 7.2.2 The equipment that contained the PCBs shall be placed in plastic bags and label PCB Contaminated Waste. Place bags in drums if possible, otherwise double bag and label.

Gas Meter Shop shall be notified that the gas meter contained PCB's and is scheduled for disposal.

- 7.2.3 The drum label must indicate:
 - 1. Item that oil came from. i.e. gas meter, gas pipeline, gas regulator
 - 2. Location where item was located.
 - 3. Date item was removed.
 - 4. Estimated weight of the oil in lbs.
- 7.2.4 Drums and bags to be disposed shall be stored in a specified location awaiting pickup.

7.3 If the analysis shows less than 50 ppm the liquid is **considered** non-PCB and **the associated waste may be** handled as a **non-hazardous** waste material.

7.3.1 The collected liquids, materials, equipment, disposable PPE and cleanup material should be bagged and placed into drums, if possible.

7.3.2 Drums/bags should be labeled Waste Material.

7.3.3 Drums/bags shall be stored in a specified location awaiting pickup.

7.3.4 Gas meters shall be drained of liquids and returned to the Gas Meter shop in the normal manner.

End of Instructions.

Operator Qualification (OQ) Required?

NO.

Appendices

NONE.

Attachments

NONE.

Compliance Requirements

NONE.

Reference Documents

NONE.

Document Rescission

PCBH 1 PCB Handling: Requirements, May 15, 2022

Revision Notes

Location of Changes	Summary of Changes
Subsection 4.5	PCB section of Ameren Illinois (AIC) Safety Manual replaced Ameren Illinois (AIC Safety Manual, Section 19.2.
Subsection 4.8	Grammatical correction – "personal" replaced "personnel"
Subsection 4.9	Inserted "potential" – inspected for potential sampling. Added of "collected equipment" – disposal of collected equipment.
Subsection 6.5	"requirements" replaced "is needed" – specify additional requirements.
Subsection 7.2	"regulated" replaced "hazards" – PCB regulated waste.

UNCONTROLLED IF PRINTED

Subsection 7.3	Revised – If the analysis shows less than 50 ppm the liquid is considered non-PCB and the associated waste may be handled as a non-hazardous waste material.
Paragraph 7.3.2	Spelling correction – "labeled" replaces "label"

PCBH 2.0 Sampling Liquid from Gas Piping Systems

1.0 Purpose

This document provide methods for sampling oily liquid hydrocarbons that are present in gas meters or gas piping systems including those in gas storage field., including items such as; regulators, valves or pig launchers/receivers.

2.0 Scope

This document addresses the following:

[3.0 Target Audience](#)

[4.0 General Information](#)

[5.0 Equipment](#)

[6.0 Sampling Liquids in Pipeline Facilities](#)

[7.0 Sampling Liquids Contained in Equipment](#)

[8.0 Testing](#)

3.0 Target Audience

- Gas Supervisor
- Gas Field Personnel
- Gas Tech Services (GTS) Supervisor
- Gas Tech Services (GTS) Personnel
- Gas Storage Field Supervisor
- Gas Storage Field Personnel
- Gas Meter Shop Personnel
- Manager Environmental Support & Waste Management

4.0 General Information

4.1 Oily liquid hydrocarbons may accumulate at:

- 4.1.1 Low points in the gas transmission or distribution system,
- 4.1.2 Gas meters,
- 4.1.3 Gas regulator station equipment,
- 4.1.4 Gas storage field piping systems,
- 4.1.5 Gas storage field facilities,
- 4.1.6 Customer piping or appliance controls

If possible, gas flow should be shut-off prior to accessing the facility for sampling.

4.2 Sampling procedures assumes the oily liquid hydrocarbon contains more than 49 ppm of PCBs.

- 4.3 Surfaces around the sampling location shall be protected from contamination due to spillage.

5.0 Equipment

- 5.1 The following equipment will need to be available when sampling:
 - 5.1.1 Inspection Form – See [PCBH 3](#).
 - 5.1.2 PPE – Safety glasses, disposable nitrile or latex gloves (one pair per sample).
 - 5.1.3 40 ml volatile organic analysis vial with Teflon (TFE) lined 1 ml caps.
 - 5.1.4 Disposable 10 ml pipettes and bulbs.
 - 5.1.5 Secondary sample container bags and labels.
 - 5.1.6 Disposable adsorbent pads, plastic sheeting or paper towels.
 - 5.1.7 Plastic disposable bags.
 - 5.1.8 Camera

6.0 Sampling Liquids in Pipeline Facilities

- 6.1 Prior to beginning sampling, inspect the area around or beneath the pipe, if there is evidence of spillage of an oily liquid, the Supervisor shall call Ameren Spill Hot Line 314-554-2683 to report evidence of a potential release of oily liquids.
- 6.2 Record appropriate information and observations about sample location on the Inspection Form. See [PCBH 3](#).
- 6.3 Photo document the sample area.
- 6.4 Put on PPE, nitrile or latex gloves, safety glasses and long sleeve shirt in addition to routine PPE.
- 6.5 Place plastic sheeting under pipeline at the sampling location if there is a possibility spillage.
- 6.6 Place absorbent pads on the sheeting.
- 6.7 Slowly open access point to determine if oily liquid hydrocarbon is present.
- 6.8 If pipeline is pressurized:
 - 6.8.1 Collect 25 to 20 ml of the oily liquid into container.
 - 6.8.2 Clean plastic container may be used to collect the sample.
 - 6.8.3 Transfer the collect liquid to the 40 ml vial.
- 6.9 If sampling a drip leg:
 - 6.9.1 Use pipette to collect sample the oily liquid that accumulates in base of cap.
 - 6.9.2 Empty pipette into 40 ml vial.
- 6.10 Label the oily liquid samples and complete Inspection Form.

NOTE:	Supervisor shall notify Ameren Environmental Support and Waste Management if an oily liquid is found or there is evi-
--------------	---

UNCONTROLLED IF PRINTED

dence of an oily liquid. Refer to **PCBH 1 Paragraph 5.2.3** for contact information.

- 6.11 Store samples out of direct sunlight, cool to 40 degrees F.
- 6.12 Wipe up spills from the sample area or fold up the plastic sheeting ensure no liquid escapes.
- 6.13 Place the removed contaminated equipment, piping and material in separate plastic bags for further inspection and possible sampling.
- 6.14 Ensure bags are securely sealed.
- 6.15 Place disposable PPE and cleanup materials in a plastic bag.
- 6.16 Place and secure bags and drums in the cargo area of a Company truck for delivery to the designated Staging area for the Operating Center.
- 6.17 Bags should be placed in drums if possible.
- 6.18 Label the drums or bags for off-site disposal.
- 6.19 Store drums at in a designated Staging area until lab results are received.

7.0 Sampling Liquids Contained in Equipment

- 7.1 When the presence of liquids in a gas meter, regulators or other equipment is recognized the following steps should be taken.
 - 7.1.1 Put on PPE, nitrile or latex gloves, safety glasses and long sleeve shirt in addition to routine PPE.
 - 7.1.2 Area under and around the equipment shall be checked for evidence of pre-existing spill.
 1. Look for visible signs of a spill.
AND
 2. Smell for the presence of mercaptan.
 3. Immediately

Gas Supervisor shall call Ameren Spill Hot Line 314-554-2683 to report evidence of a release of oily liquids.

- 3 a. Collect soil samples from beneath the meter and the disconnect points.
- 3 b. If hard surface is beneath the meter set a wipe sample may need to be taken for analysis. Refer to **PCBH 2.4 Section 5.0** Wipe Sampling

UNCONTROLLED IF PRINTED

- 7.1.3 Prior to removing the meter or equipment protect the area against any potential spill by:
 - 1. Installing plastic sheeting beneath the meter set or equipment.
 - 2. Taping plastic sheeting on the adjacent wall of the structure.
 - 3. Placing absorbent pads on the sheeting beneath the meter or equipment.
 - 4. Having plastic lined containers available to collect any oily liquids.
- 7.1.4 Shut-off gas flow to the meter or equipment
- 7.1.5 Disconnect meter or equipment from piping.
- 7.1.6 If possible, verify the presence of liquids without tipping the meter or equipment to remove liquids.
- 7.1.7 Cap, plug or seal the inlet and outlet of the meter or equipment.
- 7.1.8 Place the meter or equipment in a plastic bag.
- 7.1.9 A sample of liquid can be obtained at this point or at the Staging Area.
- 7.1.10 Check the connecting piping for evidence of an oily liquid hydrocarbon.

Gas Supervisor shall notify Ameren Environmental Support and Waste Management if an oily liquid is found or there is evidence of an oily liquid. Refer to [PCBH 1 Paragraph 5.2.3](#) for contact information.

- 7.1.11 Pipe, regulator or valve that have evidence of an oily liquids hydrocarbon shall be removed and placed in plastic bags for possible testing at the Staging Area.
- 7.2 Complete a Gas Meter Removal order in OAS/EDGE
- 7.3 Place disposable PPE and cleanup materials a plastic bag
- 7.4 Place and secure bags and drums in the cargo area of a Company truck for delivery to the designated Staging area for the Operating Center
- 7.5 Bags should be placed in drums if possible
- 7.6 Label the drums or bags for off-site disposal
- 7.7 Store drums in a designated Staging area at the Operating Center until lab results are received.

8.0 Testing

- 8.1 Refer to [PCBH 1 Section 6.0](#) Testing

End of Instructions.

Operator Qualification (OQ) Required?

NO.

UNCONTROLLED IF PRINTED

Appendices

NONE.

Attachments

NONE.

Compliance Requirements

NONE.

Reference Documents

NONE.

Document Rescission

PCBH 2.01 PCB Handling: Inspection of Residential and Commercial Properties, April 1, 2021.

PCBH 2.06 PCB Handling: Sampling Liquids from Gas Piping Systems, February 1, 2010.

Revision Notes

Location of Changes	Summary of Changes
Entire Document	Reformatted

1.0 Purpose

This document provides the instructions on what actions are to be taken based on the laboratory results of the oily liquid samples.

2.0 Scope

This document addresses the following:

[3.0 Target Audience](#)

[4.0 General Information](#)

[5.0 Positive PCB Detection](#)

[6.0 Non-PCB Detection](#)

[7.0 Inspection of Customer's Facilities](#)

3.0 Target Audience

- Gas Supervisor
- Gas Field Personnel
- Gas Tech Services (GTS) Supervisor
- Gas Tech Services (GTS) Personnel
- Gas Storage Field Supervisor
- Gas Storage Field Personnel
- Gas Meter Shop Personnel
- Manager Environmental Support & Waste Management

4.0 General Information

- 4.1 Laboratory results of 50 ppm or higher is the positive indication the oily liquids contain PCBs and are to be considered a PCB contaminated material.
- 4.2 Laboratory results of less than 50 ppm, the oily liquids is considered to be non-PCB.

5.0 Positive PCB Detection

- 5.1 Ameren Environmental Support and Waste Management shall be immediately notified that PCBs have been positively detected by a laboratory analysis.
- 5.2 Operations Management shall be notified that PCBs has been positively detected.
- 5.3 The Supervisor, (Gas, Gas Tech Services or Storage Field), shall provide the following information:
 - 5.3.1 Copy of the laboratory report.
 - 5.3.2 Gas facility sampled.
 - 5.3.3 Location of gas facility sampled.
 - 5.3.4 Additional facilities that could be affected.
 - 5.3.5 Potential impact on customer facilities.

- 5.3.6 Any indication of spillage on unprotected surfaces.
 - 5.3.7 Actions taken if there was indication of spillage.
 - 5.3.8 Was indication of spillage reported to the Spill Hot Line [PCBH 2.0 Subsection 6.1](#).
- 5.4 Ameren Environmental Support and Waste Management will determine:
- 5.4.1 If additional sampling is needed.
 - 5.4.2 What additional inspections should be performed?
 - 5.4.3 What actions should be taken by Operations personnel?
 - 5.4.4 What actions should be taken by Environment Contractor?
- 5.5 If spillage on unprotected surfaces was indicated, Ameren Environmental Support and Waste Management will evaluate and provide the spill response procedures.
- 5.6 The Supervisor, (Gas, Gas Tech Services or Storage Field), shall ensure the removed facilities where the samples were taken are properly prepared for disposal. See [PCBH 1 Section 7.0](#) Disposal.

6.0 Non-PCB Detection

- 6.1 Ameren Environmental Support and Waste Management shall be notified the laboratory results indicated a non-PCB oily liquid as present.
- 6.2 Operations Management shall determine if additional inspections are warranted.
- 6.3 The Supervisor, (Gas, Gas Tech Services or Storage Field), shall ensure the removed facilities where the samples were taken are properly prepared for disposal. See [PCBH 1 Section 7.0](#) Disposal.

7.0 Inspections of Customer's Facilities

- 7.1 If the laboratory results indicate the presence of PCBs in a gas meter, additional inspection of a customer's piping and facilities may be justified.
- 7.2 Gas Superintendent and Regional Management with input from Ameren Environmental Support and Waste Management will make that decision.
- 7.3 Ameren Environmental Support and Waste Management may provide additional information or instructions to follow during the inspection.
- 7.4 Gas Superintendent will ensure the appropriate AIC Public Relations personnel are made aware that inspection of customer facilities is being scheduled.
- 7.5 Inspection process will be as follows:
 - 7.5.1 Customer will be contacted and informed that an inspection of their facilities need to be inspected to ensure PCBs have not migrated pass the gas meter.
 - 7.5.2 Provide customer with copy of the PCB Fact Sheet. See [PCBH 3](#).
 - 7.5.3 Schedule an inspection time with the customer.
 - 1. Customer must be present at time of inspection.
 - 2. Customer must allow access to their gas facilities.

UNCONTROLLED IF PRINTED

- 7.5.4 Inspection of the facilities shall follow the same procedures for protecting the customer's premises from unintentional contamination as described in **PCBH 2.0** Sampling Liquids from Gas Piping Systems.
- 7.5.5 If oily liquid hydrocarbon is found in the customer's facilities, the item shall be removed, placed in plastic bag, transported to and sampled at the Staging Area.
1. Removed item shall be replaced.
 2. Sampling of item for PCBs shall be in accordance with **PCBH 2.0**
 3. Disposal of the item will be in accordance with **PCBH 1 Section 7.0** Disposal
- 7.5.6 The following materials that may be needed would include such items as:

Materials
Pan
5-gallon bucket (22 08 272)
Plastic sheeting (49 06 201)
Pipe caps
Pipe nipples
Lables
Duct tape
Meter Exchange Tags
Absorbent pads

End of Instructions.

Operator Qualification (OQ) Required?

NO.

Appendices

NONE.

Attachments

NONE.

Compliance Requirements

NONE.

Reference Documents

NONE.

Document Rescission

PCBH 2.1 PCB Handling: Positive PCB Detection, October 1, 2021

Revision Notes

Location of Changes	Summary of Changes
Paragraph 5.3.8	Reference link to Spill Hot Line phone number added: PCBH 2.0 Subsection 6.1.

PCBH 2.2 Staging Area and Disposal Protocol

1.0 Purpose

This sections provides information and procedures for handling collected material at the Staging Area and the Disposal pickup location.

2.0 Scope

This document addresses the following:

[3.0 Target Audience](#)

[4.0 General Information](#)

[5.0 Staging Area Protocol](#)

[6.0 Disposal Area Protocol](#)

3.0 Target Audience

- Gas Supervisor
- Gas Field Personnel
- Gas Tech Services (GTS) Supervisor
- Gas Tech Services (GTS) Personnel
- Gas Storage Field Supervisor
- Gas Storage Field Personnel
- Gas Meter Shop Personnel
- Storeroom Personnel
- Manager Environmental Support & Waste Management

4.0 General Information

- 4.1 Staging Area is a designated location at the Operating Center or Gas Storage Field where the removed equipment and material collected during the sampling operations are to be stored until the results of the laboratory analysis are received.
- 4.2 GTS Supervisors should either utilize an Operating Center's designated Staging Area or designate their own Staging Area.
- 4.3 Sampling of oily liquids contained in the equipment may be required at the Staging Area.
- 4.4 The laboratory results will dictate how the collected samples are to be handled for disposal.
 - 4.4.1 50 ppm PCB or greater is a PCB contaminated waste requiring licensed waste hauler to a licensed disposal site.
 - 4.4.2 Less than 50 ppm PCB can be disposed of as general waste.
- 4.5 Operating Center Supervisor, GTS Supervisor and Gas Storage Field Supervisor will consult with the AIC Storeroom Supervisor as to the location of the disposable material pick-up site for.
 - 4.5.1 PCB contaminated waste.

4.5.2 Non-PCB waste.

- 4.6 Stores personnel will coordinate with Environmental Support & Waste Management on the pick-up of the PCB contaminated waste.

5.0 Staging Area Protocol

- 5.1 Items collected and bagged at the worksite should be placed in 55 gallon steel drums with lids.
- 5.2 The drums are to be labeled as to their content.
- 5.3 Material items such as pipe, drip leg and fittings should be placed in a separate drum than disposable PPE, plastic sheeting, absorbent pads and clean-up materials.
- 5.4 Gas meters containing liquids will need to be placed in a separate drum after samples of the liquid are obtained.
- 5.5 Sampling of the oily liquid hydrocarbon shall follow the sampling procedures in [PCBH 2.0](#) Sampling Liquid from Gas System.

Ensure area is protected from any spillage prior to beginning sampling operations.

- 5.6 The results of laboratory analysis will determine how the Staging Area material will be handled.
- 5.6.1 Laboratory analysis results show 50 ppm or more of PCB:
1. Item is considered contaminated with PCBs.
 2. The drums containing the sampled item along with all the material collected at the site shall have an Ameren Caution Contains PCB label.
 3. Gas Supervisor, GTS Supervisor or Gas Storage Field Supervisor shall notify Manager Environmental Support and Waste Management that PCB contaminated material will be delivered to the designated Disposal pick-up location.
 4. If a gas meter is found contain PCB liquid, contact Gas Meter Shop.
 - 4 a. Gas Supervisor shall advise Gas Meter Shop Supervisor that the gas meter is to be disposed.
 - 4 b. Obtain the instructions on the required steps to have the meter removed from meter inventory.
 5. Gas Supervisor shall notify local Storeroom Supervisor as when the contaminated material will be delivered.
- 5.6.2 Laboratory analysis results show less than 50 ppm of PCB.
1. Item is considered non-PCB.
 2. The drums containing the sampled item along with all the material collected at the site shall be labeled as Waste Material.

3. Gas Supervisor, GTS Supervisor or Gas Storage Field Supervisor shall notify Manager Environmental Support and Waste Management that non-PCB material will be delivered to the designated Disposal pick-up location.
4. Gas Supervisor shall notify Gas Meter Shop supervisor that the gas meter did not contain PCB liquids. Refer to [PCBH 1 Paragraph 7.3.4](#).

6.0 Disposal Area Protocol

- 6.1 The drums containing the PCB contaminated material shall be delivered to the designated waste pick-up location.
 - 6.1.1 Gas Supervisor, GTS Supervisor or Gas Storage Field Supervisor shall confirm with Storeroom personnel and Environmental Support the pick-up location and delivery of the material.
 - 6.1.2 Environmental Support will arrange and coordinate the pick-up with a licensed hazardous waste hauler.
- 6.2 Refer to [PCBH 1 Section 7.0](#) Disposal for more details.

End of Instructions.

Operator Qualification (OQ) Required?

NO.

Appendices

NONE.

Attachments

NONE.

Compliance Requirements

NONE.

Reference Documents

NONE.

Document Rescission

PCBH 2.04 – Liquid Inspection Protocol Staging Area, January 1, 2011

Revision Notes

Location of Changes	Summary of Changes
Entire Document	Reformatted

UNCONTROLLED IF PRINTED

1.0 Purpose

This document provides procedures to follow if oily liquids are released from a meter, appliance drip leg or gas piping facilities either during routine work or when conducting an inspection.

2.0 Scope

This document addresses the following:

[3.0 Target Audience](#)

[4.0 PPE for Liquid Release Cleanup](#)

[5.0 Inside Home Release](#)

[6.0 Outside Release](#)

3.0 Target Audience

- Gas Supervisor
- Gas Field Personnel
- Gas Tech Services (GTS) Supervisor
- Gas Tech Services (GTS) Personnel
- Gas Storage Field Supervisor
- Gas Storage Field Personnel
- Gas Meter Shop Personnel
- Manager Environmental Support & Waste Management

4.0 PPE for Liquid Release Cleanup

4.1 All or part of the listed PPE may be worn depending on the release size:

- 4.1.1 Nitrile or latex gloves.
- 4.1.2 Safety glasses.
- 4.1.3 Tyvek suit.
- 4.1.4 Disposable PVC boots.
- 4.1.5 Face shield or goggles if splashing liquids is possible.

5.0 Inside Home Release

5.1 If the oily liquid is released into a bucket, onto plastic sheeting or absorbent pads, gas field personnel shall do the following:

- 5.1.1 Seal the item from which the oily liquid was released.
- 5.1.2 Release into bucket:
 1. Close the plastic bag, if one is in the bucket, or

2. Place bucket in a plastic bag and close the bag
3. Carry the bucket out of the house and secure in the cargo area of a Company truck.

Remove from the house as soon as possible to minimize indoor odors

5.1.3 Release onto plastic sheeting or absorbent pads:

1. Carefully wrap them up in the plastic sheeting ensuring not to spill any of the liquid.
2. Place in a bucket or a plastic bag.
3. Carry the bucket or plastic bag out of the house and secure in the cargo area of a Company truck.

5.1.4 Place the disposable PPE in a plastic bag and secure in the cargo area of a Company truck.

5.1.5 Take the items to the designated location at the Operating Center and place them in 55 gallon drums. Refer to [PCBH 1 Subsection 4.9](#) Staging area.

5.1.6 Obtain sample of liquid. Refer to [PCBH 2.0 Subsection 7.2](#) Sampling the oily liquid.

5.1.7 No additional cleanup or environmental testing will be necessary.

5.2 If the oily liquid is released onto unprotected surfaces inside the home, gas field personnel shall do the following:

5.2.1 Contact Gas Supervisor and provide details of the situation.

5.2.2 Put on the appropriate PPE to prevent direct contact with the liquid. Refer to [Subsection 4.1](#).

1. If appropriate PPE is not readily available:
 - 1 a. Contact Supervisor to have PPE brought to site.
 - 1 b. Keep everyone away from the area.
 - 1 c. If possible, take necessary steps to keep liquids from entering floor drains.

5.2.3 Immediately place absorbent pads on the spilled liquid.

5.2.4 Place absorbent pads around floor drains, where applicable.

5.2.5 Gas Supervisor shall:

1. Immediately call Ameren Spill Hotline, [PCBH 2.0 Subsection 6.1](#), to report the spill.
2. Contact Ameren Environment Support and Waste Management to report the release. Refer to [PCBH 1 Paragraph 5.2.3](#) for contact information.
3. Ameren Environment Support and Waste Management personnel will advise Gas Supervisor as to actions that should be taken.

UNCONTROLLED IF PRINTED

- 5.2.6 Soak up and wipe up the spilled material as best as possible.
- 5.2.7 If permanent cleanup cannot be immediately performed:
 - 1. Cover the area with absorbent pads.
 - 2. Cover the pad and area with plastic sheeting to prevent tracking.
 - 3. Ask homeowner to avoid the area until permanent cleanup is performed.

Depending on the size and quantity of the release, Ameren Environmental Support and Waste Management may schedule a qualified spill contractor to perform the permanent cleanup

- 5.2.8 Place cleanup materials and disposable PPE in a plastic bag and place in the cargo area of a Company truck.
- 5.2.9 Take the items to the designated location at the Operating Center and place them in 55 gallon drums. Refer to [PCBH 1 Subsection 4.9](#) Staging area.
- 5.2.10 Gas Supervisor shall consult with Environmental Support and Waste Management on how to clean-up materials should be sampled.

6.0 Outside Release

- 6.1 If the oily liquid is released onto a protected outside surface such as into a bucket, onto plastic sheeting or onto absorbent pads the gas field personnel shall do the following:
 - 6.1.1 Seal the item from which the oily liquid was released.
 - 6.1.2 Release into bucket:
 - 1. Close the plastic bag, if one is in the bucket, or
 - 2. Place bucket in a plastic bag and close the bag
 - 3. Place the bucket and secure in the cargo area of a Company truck.
 - 6.1.3 Released onto plastic sheeting or absorbent pads:
 - 1. Carefully wrap them up in the plastic sheeting ensuring not to spill any of the liquid.
 - 2. Place in a bucket or a plastic bag.
 - 3. Carry the bucket or plastic bag out of the house and secure in the cargo area of a Company truck.
 - 6.1.4 Place the disposable PPE in a plastic bag and secure it in the cargo area of a Company truck.
 - 6.1.5 Take the items to the designated location at the Operating Center and place them in 55 gallon drums. Refer to [PCBH 1 Subsection 4.9](#) Staging area.
 - 6.1.6 Obtain sample of liquid. Refer to [PCBH 2.0 Subsection 7.2](#) Sampling the oily liquid.
 - 6.1.7 No additional cleanup or environmental testing will be necessary.

- 6.2 If the oily liquid is released on unprotected outside surface, gas field personnel shall do the following:
- 6.2.1 Contact Gas Supervisor and provide details of the situation.
 - 6.2.2 Put on the appropriate PPE to prevent direct contact with the liquid. Refer to [Subsection 4.1](#).
 - 1. If appropriate PPE is not readily available:
 - 1 a. Contact Supervisor to have PPE brought to site.
 - 1 b. Keep everyone away from the area.
 - 1 c. If possible, take necessary steps to keep liquids from entering floor drains.
 - 6.2.3 Immediately place absorbent pads on the spilled liquid.
 - 6.2.4 Place absorbent pads around floor drains, where applicable.
 - 6.2.5 Gas Supervisor shall:
 - 1. Immediately call Ameren Spill Hotline, [PCBH 2.0 Subsection 6.1](#), to report the spill.
 - 2. Contact Ameren Environment Support and Waste Management to report the release. Refer to [PCBH 1 Paragraph 5.2.3](#) for contact information.
 - 3. Ameren Environment Support and Waste Management personnel will advise Gas Supervisor as to actions that should be taken.
 - 6.2.6 Soak up and wipe up the spilled material as best as possible.
 - 6.2.7 Follow the instruction provided by Environment Support and Waste Management personnel on how to remove or treat the spill area.
 - 6.2.8 Place cleanup materials and disposable PPE in a plastic bag and place in the cargo area of a Company truck.
 - 6.2.9 Take the items to the designated location at the Operating Center and place them in 55 gallon drums. Refer to [PCBH 1 Subsection 4.9](#) Staging area.

End of Instructions.

Operator Qualification (OQ) Required?

NONE.

Appendices

NONE.

Attachments

NONE.

Compliance Requirements

NONE.

Reference Documents

NONE.

UNCONTROLLED IF PRINTED

Document Rescission

PCBH 2.3 PCB Handling: Liquid Release Protocol, October 1, 2021

Revision Notes

Location of Changes	Summary of Changes
Paragraph 5.2.5	Hyperlink PCBH 2.0 Subsection 6.1 , replaces the Spill Hot Line phone number.
Paragraph 6.2.5 – Item 1.	Hyperlink PCBH 2.0 Subsection 6.1 , replaces the Spill Hot Line phone number.

PCBH 2.4 Wipe and Soil Sampling**1.0 Purpose**

This section provides the instructions for collecting Wipe Samples and Surface Soil Samples for analysis of PCB contamination

2.0 Scope

This document addresses the following:

[3.0 Target Audience](#)[4.0 General Information](#)[5.0 Wipe Sampling](#)[6.0 Soil Sampling](#)**3.0 Target Audience**

- Gas Supervisor
- Gas Field Personnel
- Gas Tech Services (GTS) Supervisor
- Gas Tech Services (GTS) Personnel
- Gas Storage Field Supervisor
- Gas Storage Field Personnel
- Gas Meter Shop Personnel
- Manager Environmental Support & Waste Management

4.0 General Information

- 4.1 Solid or soil surfaces that have been exposed to oily liquid hydrocarbons may need to be sampled to determine if they are PCB contaminated.
- 4.2 Solid surfaces such as metal, concrete or asphalt will require a wipe sample.
- 4.3 The wipe sample is accomplished by using a sterile pads or filter paper, saturated with a hexane solution, to wipe the surface. A template with a cutout area of 10 cm x 10 cm will define the area to be wiped.

Hexane is flammable, no smoking or open flames are allowed during sampling.

- 4.4 Wipe sampling should be performed in a well-ventilated area.
- 4.5 Surface soil samples typically involved shallow sampling, up to 3 inches in depth, of the soil.
 - 4.5.1 Samples are obtained using hand tools to collect the samples. A clean disposable nitrile or latex glove should be worn for sample collection.
 - 4.5.2 Clean shovels, trowels or other tools may be used to initially loosen the soil from around the perimeter of the area to be sampled.

- 4.5.3 The tools used to loosen the soil should not come in contact with the soil being sampled.

5.0 Wipe Sampling

5.1 The following equipment will be needed:

- 5.1.1 Sampling Form. Refer to [PCBH 3](#).
- 5.1.2 PPE – Safety glasses, disposable nitrile or latex gloves (one pair per sample).
- 5.1.3 Wipe Kits – Provided by Ameren Laboratory Services. Refer to [PCBH 1 Section 6.0](#).
 - 1. Sample container.
 - 2. Hexane solvent.
 - 3. Sterile pads.
 - 4. Sampling template.
- 5.1.4 Sampling template with 10 cm x 10 cm cutout , and masking tape.
- 5.1.5 Secondary sample container bags and labels.
- 5.1.6 Plastic disposable bags.
- 5.1.7 Camera.

5.2 The following procedures should be followed as closely as possible depending on the surface being sampled.

- 5.2.1 Record the appropriate information and observations of the sampling location on the Sampling Form. Refer to [PCBH 3](#).
- 5.2.2 Photo document the sample area.
- 5.2.3 Open the Sampling Kit.
 - 1. Prepare a blank sample:
 - 2. Saturate a sterile pad with the hexane solution.
 - 3. Place the saturate sterile pad in the sampling container.
 - 4. Label as Blank Sample.

Blank sample is used to identify potential introduction of contaminants through the sampling methods, the pad, solvent of sample container

- 5.2.4 Place the sampling template over the area and secure with the masking tape.
- 5.2.5 Put on a new pair of disposable nitrile or latex gloves.
- 5.2.6 Saturate a sterile pad with the hexane solution.
- 5.2.7 Wipe the template area using firm strokes:
 - 1. Use only one side of the sterile pad to wipe the area.

UNCONTROLLED IF PRINTED

2. Wipe the sample area vertically twice with the sterile pad, then,
3. Wipe the sample area horizontally twice with the same sterile pad.

Insure the sample area has been completely wiped.

4. Place the sterile pad in the sample container and close.
 5. Label the sample and complete the documentation on Sampling Form.
 6. Store out of direct sunlight, cool to 40 degrees F.
- 5.3 If additional wipe samples are needed on the same item, follow the above process for each wipe sample except a Blank Sample is not required unless the sampling extends beyond one day.
- 5.4 Refer to [PCBH 1 Section 6.0](#) Testing for information on sending samples to Ameren Laboratory Services.

6.0 Soil Sampling

- 6.1 The following equipment will be needed:
- 6.1.1 Sampling Form. Refer to [PCBH 3](#).
 - 6.1.2 PPE – Safety glasses, disposable nitrile or latex gloves (one pair per sample).
 - 6.1.3 Laboratory cleaned 4 oz. sample containers available from Ameren Laboratory Services. Refer to [PCBH 1 Section 6.0](#).
 - 6.1.4 Secondary sample container bags and labels
 - 6.1.5 Clean shovel or stainless steel trowels.
 - 6.1.6 Plastic disposal bags.
 - 6.1.7 Camera
- 6.2 The following procedures should be followed as closely as possible depending on the surface being sampled.
- 6.2.1 Single use disposable nitrile or latex gloves and sampling tools.
 - 6.2.2 Sampling tools shall be clean and free of dirt or other contaminants. A clean stainless steel trowels is an acceptable sampling tool.
 - 6.2.3 Record appropriate information and observations about the sampling location on the Sampling Form. Refer to [PCBH 3](#).
 - 6.2.4 Photo document the selected sample area.
 - 6.2.5 If necessary, a clean spade or trowel may be utilized to loosen the soil around the perimeter of the sample area prior to sample collection.

The spade and trowel used to loosen the soil shall not be used to collect the sample and should avoid contact with the soils to be collected for analysis.

6.2.6 Put on new pair of disposable nitrile or latex gloves.

6.2.7 Collect soil sample using hand collection method and place in the laboratory provided container. A clean tool should be used to assist in the collection.

1. Remove and discard any of the following from the soil sample:

1 a. Large rocks.

1 b. Organic material such as roots, twigs, insects, worms, etc.

6.2.8 Label the sample and complete the documentation on Sampling Form.

6.2.9 Store the sample out of direct sunlight.

6.3 If additional soil samples are needed from the same area, follow the above process for sample.

6.4 Refer to [PCBH 1 Section 6.0](#) Testing for information on sending samples to Ameren Laboratory Services.

End of Instructions.

Operator Qualification (OQ) Required?

NO.

Appendices

NONE.

Attachments

NONE.

Compliance Requirements

NONE.

Reference Documents

NONE.

Document Rescission

PCBH 2.4 PCB Handling: Wipe and Soil Sampling, October 1, 2021

Revision Notes

Location of Changes	Summary of Changes
Throughout this document	Ameren Laboratory Services replaced Ameren UEC Laboratory Services

UNCONTROLLED IF PRINTED

PCB Handling

October 1, 2021

PCBH 3 Forms and Reference Materials

These documents are available on the Organizational Data Drive at O:\Gas Operating & Maintenance Plan\PCBH - PCB Handling\Forms and Reference Materials

Forms

[1. PCB Fact Sheet \(Rev. 04/01/2021\)](#)

[2. Sampling Inspection Form](#)

End of Section.

Document Rescission

PCBH 4 Forms and Reference Materials, April 1, 2021

Revision Notes

Location of Changes	Summary of Changes
Entire Document	Reformatted

PIGG-Pigging

PIGGING

October 1, 2020

PIGG 0 Table of Contents

PIGG 1 Pigging: Requirement

- Section 1.0 Purpose
- Section 2.0 Scope
- Section 3.0 Target Audience
- Section 4.0 Requirements
- Operator Qualification (OQ)
- Compliance Requirements
- Reference Documents
- Document Rescission

PIGG 2.1 Pigging: Pigging Operation

- Section 1.0 Purpose
- Section 2.0 Scope
- Section 3.0 Target Audience
- Section 4.0 Pigging Process
- Section 5.0 Types of Pigs
- Section 6.0 Launching and Receiving Process
- Section 7.0 Safety and Environmental
- Section 8.0 Natural Gas Pipeline Materials
- Section 9.0 Personal Protective Measures
- Section 10.0 Disposal of Waste Material or Clean PPE After Use
- Operator Qualification (OQ)
- Compliance Requirements
- Reference Documents
- Document Rescission

End Table of Contents.

Document Rescission

PIGG 0 Pigging: Table of Contents, July 1, 2020.

UNCONTROLLED IF PRINTED

Revision Notes

Location of Changes	Summary of Changes
Not applicable.	This is a new document.

PIGG 1 Requirement

1.0 Purpose

This procedure provides requirements for pigging in accordance with 49 CFR §§ 192.493 and 192.750.

2.0 Scope

This document addresses the following:

[3.0 Target Audience](#)

[4.0 Requirements](#)

3.0 Target Audience

- Gas Tech Engineering (GTE)
- Gas Integrity Management (IM)
- Supervisor Corrosion Control
- Gas Tech Services (GTS) Supervisors
- Gas Tech Services (GTS) Personnel

4.0 Requirements

- 4.1 Gas Tech Engineering (GTE) and Gas Integrity Management (IM) shall prepare written project specific pigging plan with procedures to safely complete the planned operation.
- 4.1.1 In-line inspection (ILI) project plan procedures shall be in accordance with Ameren Illinois (AIC) Pipeline Integrity Management In-Line Inspection Procedures. These procedures shall be in comply with the references listed in 49 CFR §192.493.
- 4.1.2 The plan shall be reviewed with the project personnel prior to beginning pigging operations.
- 4.2 Each new transmission line and each section of a transmission line where the pipe, valve, fitting, or other component is replaced, must be designed and constructed to accommodate the passage of an instrumented ILI tool.
- 4.2.1 This requirement does not apply to the following:
1. Manifolds.
 2. Station piping at regulator stations or meter station.
 3. Piping associated with natural gas underground storage facilities unless the piping is a continuous run of transmission line between storage facilities.
 4. Crossovers.
 5. An ILI tool is not commercially available for the size of pipe being installed.
- 4.2.2 Construction of new or replaced transmission line to accommodate an ILI tool is not required if:
1. An emergency is encountered.
 2. Unforeseen construction problems arise.
 3. Construction time restraints exists.

4. Operator determines it is impractical.

Within 30 days after discovering one of the above conditions exist, AIC Pipeline Integrity Management shall petition PHMSA for approval, in accordance with 49 CFR §190.9. If petition is denied within 1 year of submittal, AIC shall modify that section to accommodate passage of an ILI.

4.2.3 Any launcher or receiver used after July, 2021 shall be equipped with a device capable of safely relieving pressure in the barrel before removal or opening.

4.2.4 Launchers and receivers shall be pressure tested to at least the MAOP of the line being pigged. Refer to [PTST 1.1 Appendix E](#) Fabricated Unit/Assembly or Short Sections of Pipe.

End of Instructions.

Operator Qualification (OQ) Required?

NO.

Appendices

NONE.

Attachments

NONE.

Compliance Requirements

49 CFR §190.9 Petitions for finding or approval.

49 CFR §192.493 In-Line inspection of pipelines.

49 CFR §192.750 Launcher and receiver safety.

Reference Documents

[PTST 1.1 Pressure Testing: Test Pressure and Duration Requirements Tables](#)

Document Rescission

PIGG 1 Pigging: Requirements, July 1, 2020.

Revision Notes

Location of Changes	Summary of Changes
Not applicable.	This is a new document.

PIGG 2.1 Pigging Operation

1.0 Purpose

This procedure provides the instructions for activities related to pigging of transmission pipeline facilitates.

2.0 Scope

This document addresses the following:

[3.0 Target Audience](#)

[4.0 Pigging Process](#)

[5.0 Types of Pigs](#)

[6.0 Launching and Receiving Process](#)

[7.0 Safety and Environmental](#)

[8.0 Natural Gas Pipeline Materials](#)

[9.0 Personal Protective Measures](#)

[10.0 Disposal of Waste Material or Clean PPE After Use](#)

3.0 Target Audience

- Gas Tech Engineering (GTE)
- Gas Integrity Management (IM)
- Supervisor Corrosion Control
- Gas Control
- Gas Construction Personnel
- Gas Tech Services (GTS) Supervisors
- Gas Tech Services (GTS) Personnel

4.0 Pigging Process

4.1 Pigging refers to the practice of using internal pipeline tools called "pigs" to perform maintenance or inspection activities on pipelines without disrupting its operation.

4.2 Pigging activities can be one or more of the following:

4.2.1 Removal of debris from pipelines such as:

1. Mill scale.
2. Rust.
3. Dirt.
4. Fluids.

4.2.2 In-line inspection (ILI) of the the pipe to gather information that may include:

1. Corrosion.
2. Cracks.
3. Pipe deformation.
4. Wall thickness variations.

4.2.3 Establishing a baseline for future comparison for integrity purposes.

4.3 A pig is normally propelled through the pipeline using available gas pressure, compressed air, water, remote controlled robotic technology, or tethered application. See [Figure 6](#).

4.3.1 The pig must travel the length of inspectable pipeline at steady and controllable speeds.

4.3.2 The pig will be an acceptable obstruction and will need a positive pressure behind it (the differential pressure) to cause it to move.

4.3.3 Any variation in the amount of obstruction (i.e., debris, liquids, etc.) will change the differential pressure necessary to move the pig.

1. This may result in a stop-start motion, known as speed excursions, which should be avoided.

4.4 Average pressure required for pigging will vary depending on the type of pig and the pipeline outside diameter and length.

The pressure shall not exceed the maximum allowable operating pressure (MAOP) of the line.

4.5 Launching and receiving pig traps are required.

4.5.1 A launcher is required at the upstream end of the section to be pigged to introduce the pig into the pipeline.

4.5.2 A receiver is at the downstream end of the pipeline section being pigged to land the pig.

4.5.3 All launcher or receiver pig traps shall be equipped with a pressure relief device. Before inserting or removing pigs, relieve pressure in the barrel to prevent opening of the pig traps while under pressure.

5.0 Types of Pigs

5.1 Pigs typically used at Ameren Illinois (AIC) include the following.

5.1.1 Poly / Foam Pigs

1. Soft and made out malleable foam (See [Figure 1](#)):
2. Generally used for pipe cleaning prior to maintenance and inspection.



Figure 1: Foam Cleaning Pig

5.1.2 Brush or Scraper Pigs (See [Figure 2](#)):

1. Used for aggressive cleaning.



Figure 2: Brush Cleaning Pig

5.1.3 Gauging Pigs (See Figure 3 and 4):

1. Used to confirm a minimum internal pipeline diameter.
2. A gauge plate attached to a brush or scraper pig sized slightly smaller than the pipeline diameter is used to determine the minimum internal pipeline diameter.
3. Deflections to the gauge plate can be measured to identify if a smart pig can successfully pass through the pipeline.



Figure 3: Gauging Pig



Figure 4: Bent Gauge Plate

5.1.4 Smart or Intelligent pigs (ILI Tool): (See Figure 5)

1. ILI tools for geometry or metal loss will be particular to the ILI vendor and specific capabilities may vary.



Figure 5: Combination Smart Pig and Cleaning Pig

6.0 Launching and Receiving Process

- 6.1 The written pigging plan shall include procedures for performing the following activities which are common with all types of pigs. See Figure 6 for a schematic of pig launching and receiving facilities.
- 6.2 Typical activities conducted during launching operations:
 - 6.2.1 Isolate launching trap.
 - 6.2.2 Drain and depressurize the launching trap.
 1. If ILI pig is to be launched, ensure all tool diagnostic checks are complete and operational (ready to load).
 - 6.2.3 Load the pig until front cups or discs are firmly seated into the reduced section of the trap.
 1. Open equalizing valve between the launching trap and the pipeline to ensure the pig does not unseat.

Damage may occur if the ILI tool hits the trap isolation valve before or when being launched.

- 6.2.4 Contact Gas Control to ensure the desired inspection flow rate is achieved.
- 6.2.5 Open the trap isolation valve.
- 6.2.6 Launch the pig by diverting and increasing flow through the kicker line (see [Figure 6](#)) while isolating the normal operations valve.
- 6.2.7 Restore launching trap to original state.
- 6.3 Typical activities conducted during receiving operations:
 - 6.3.1 Set up the receiving trap by ensuring valve settings are appropriate as outlined in pigging procedure.

If using ILI tool, damage may occur if the tool hits the trap isolation valve or receiver closure door.

6.3.2 Receive the pig:

1. If using ILLI tool, ensure pig has cleared the isolation valve otherwise damage may occur when attempting to isolate trap by closing valve.

6.3.3 Open mainline valve.

6.3.4 Close the kicker line/bypass valve.

6.3.5 Close the receiver trap valve.

6.3.6 Drain and depressurize the receiving trap.

Be aware of the pressure which may be trapped between the tool modules.

6.3.7 Ensure area behind the receiving trap closure door is clear of personnel and equipment (line of fire).

6.3.8 Per environmental guidelines, be prepared to capture any line debris.

6.3.9 Open receiver trap closure door.

6.3.10 Remove the pig.

6.3.11 Restore the receiving launcher to original state.

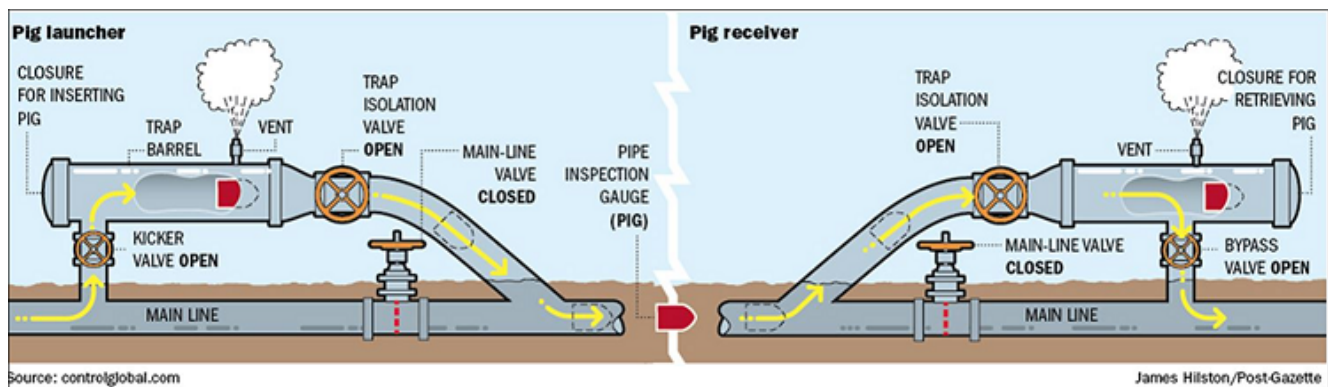

Figure 6: Pig Launching and Receiving Schematic

7.0 Safety and Environmental

7.1 Contact AIC Safety Supervisor with questions regarding:

7.1.1 Safe work procedures.

7.1.2 PPE, or

7.1.3 Arrangements for additional screening for radiation.

7.2 Contact Ameren Environment Services prior to beginning the pigging operation with questions about:

7.2.1 Testing.

7.2.2 Appropriate handling and/or disposal.

7.3 Significant and detailed planning efforts shall be taken to ensure the safety of workers, public and property during each pigging operation.

UNCONTROLLED IF PRINTED

- 7.3.1 All unauthorized individuals and public shall be kept away from launcher and receiving areas.
 - 7.3.2 AIC personnel shall monitor pressure to ensure pipeline pressure does not exceed the pipeline MAOP.
 - 7.4 Pigging plan shall address environmental issues which can be anticipated:
 - 7.4.1 AIC personnel shall follow guidelines for safe handling, sampling and disposal of solids and/or fluids.
 - 7.4.2 Solids and fluids removed from the pipeline shall be considered for sampling and testing for PCBs or other hazardous or detrimental constituents. Refer to [PCBH 2.0](#).
 - 7.4.3 Pipeline scale and sludge may contain low levels of iron sulfide.
 - 1. Iron sulfide can be an eye, skin, and respiratory irritant.
 - 2. Iron sulfide carries the risk of spontaneous combustion when dry.
- Iron sulfides removed from a pipe must be kept wet or stored in a sealed barrel to prevent combustion and harm to personnel.
- 7.4.4 Specific testing and waste handling may be required depending on the waste sampling profiles
 - 7.4.5 Results of the testing will be evaluated for determining the appropriate waste disposal method.
 - 1. Cleaning pigs (foam and/or cups, discs, etc.) may need to be disposed of in a similar manner as the solids and fluids.
 - 2. Containment and storage for these pigs should be considered.

8.0 Natural Gas Pipeline Materials

- 8.1 Natural gas materials may contain low levels of:
 - 8.1.1 Naturally Occurring Radioactive Materials (NORM)
 - 8.1.2 Iron sulfide
 - 8.1.3 Polychlorinated Biphenyls (PCBs).
- 8.2 NORM may be present in natural gas as a result of geological formations where the gas was extracted.
 - 8.2.1 NORM exists in the form of particulate radionuclides in sludge or scale, as well as radon gas.
 - 8.2.2 The scale and sludge can be unpredictable in form (wet or dry).
 - 8.2.3 Radiation content in the scale/sludge is generally very low, and is short-lived, returning to background levels within 24 hours of removal of the gas source.
 - 8.2.4 NORM presents a risk only if it is ingested or inhaled.
 - 8.2.5 The potential risk of inhalation is considered low.
- 8.3 Pipeline scale and sludge may contain low levels of iron sulfide. Refer to section [7.4.3](#).

9.0 Personal Protective Measures

- 9.1 The primary potential routes of exposure to these materials are:
- 9.1.1 Through the skin, or
 - 9.1.2 Through inadvertent ingestion, such as eating food with contaminated hands.
 - 9.1.3 Airborne exposure to these materials is also possible, however the risk is considered very low, due to the nature of the materials.
 - 9.1.4 Exposure protection primarily involves:
 - 1. Prevent skin contact by wearing appropriate PPE and good hygiene.
 - 2. Limit work areas to personnel who have the required training and PPE.
 - 9.1.5 Respirator use is voluntary.
 - 1. If respirators are worn, they shall be NIOSH-approved with tight-fitting face pieces and P100/organic vapor cartridges
 - 2. Users must be medically qualified and trained for respirator use.

10.0 Disposal of Waste Material or Clean PPE After Use

- 10.1 Prior to removing material from the pipeline:
- 10.1.1 It may be necessary to cover ground surfaces with plastic sheeting to prevent contamination.
 - 10.1.2 Approved waste containers shall be available, if needed.
 - 10.1.3 Any contact with clothing or body parts contaminated with internal pipeline liquids or debris shall be cleaned with soap and water before eating, drinking, or other activities.
 - 10.1.4 Clean tools and equipment as necessary.

End of Instructions.

Operator Qualification (OQ) Required?

YES

- 0151: Visual Inspection of Buried Pipe and Components when Exposed
- 0201: Visual Inspection of Installed Pipe and Components for Mechanical Damage
- 0301: Manually Opening and Closing Valves
- 0311: Adjust and Monitor Flow or Pressure - Manual Valve Operation
- 0321: Valve Corrective Maintenance
- 0331: Valve - Visual Inspection and Partial Operation
- 0341: Valve - Preventive Maintenance
- 1371: Operate Gas Pipeline - System Control Center Operations
- 1411: Indirect Inspection Techniques
- 1421: Direct Examination Techniques

UNCONTROLLED IF PRINTED

1631: Launching and/or Receiving Internal Devices (Pigs) with a Temporary Launcher and/or Receiver for Lines Out of Service

1641: Launching and/or Receiving Internal Devices (Pigs) for Line In-Service

Appendices

NONE.

Attachments

NONE.

Compliance Requirements

NONE.

Reference Documents

[PCBH 2 PCB Handling: Sampling Liquid from Gas Piping Systems](#)

Document Rescission

PIGG 2.1 Pigging: Pigging Operation, October 1, 2020.

Revision Notes

Location of Changes	Summary of Changes
Target Audience	Added Gas Control

PMRK-Pipeline Markers

PIPELINE MARKERS

October 1, 2020

PMRK 0 Table of Contents

[PMRK 1 Pipeline Markers: Requirements](#)

Section 1.0 Purpose
Section 2.0 Scope
Section 3.0 Target Audience
Section 4.0 Maintenance
Section 5.0 Line Marker Warning
Section 6.0 Placement
Operator Qualification (OQ)
Compliance Requirements
Document Rescission

[PMRK 2 Pipeline Markers: Pipeline Facility Markers](#)

Section 1.0 Purpose
Section 2.0 Scope
Section 3.0 Target Audience
Section 4.0 Safety
Section 5.0 Pipeline Markers (See Appendix A)
Section 6.0 Pipeline Marker Signs (See Appendix B)
Operator Qualification (OQ)
Appendices
 Appendix A - Pipeline Markers
 Appendix B - Pipeline Marker Signs
Compliance Requirements
Document Rescission

End of Table of Contents.

Document Rescission

PMRK 0 Pipeline Markers: Table of Contents, September 1, 2016.

Revision Notes

UNCONTROLLED IF PRINTED

Location of Changes	Summary of Changes
Not applicable.	This is a new document.

PIPELINE MARKERS

April 1, 2023

PMRK 1 Requirements

1.0 Purpose

This document specifies the requirements for the installation and maintenance of markers and signage for gas pipeline facilities.

Installed pipeline markers and signs must meet the minimum requirements of 49 CFR §192.707.

2.0 Scope

This document addresses the following:

[3.0 Target Audience](#)[4.0 Maintenance](#)[5.0 Line Marker Warning](#)[6.0 Placement](#)

3.0 Target Audience

- Gas Engineering
- Gas Distribution Design Specialist
- Gas Field Personnel
- Gas Supervisors
- Gas Construction Services Personnel
- Gas Storage Field Supervisor
- Gas Storage Field Personnel

4.0 Maintenance

- 4.1 Pipeline facilities must be properly marked and maintained.
- 4.2 Gas Supervisor or Gas Storage Field Supervisor is responsible for ensuring that all gas pipeline facilities have the proper type and amount of signage.
- 4.3 Inspect signs and line markers during routine patrols.

Repair and replace deteriorated signs and line markers.

- 4.4 All pipeline markers and signs installed on pipeline facilities, regulator stations, odorization stations, and storage fields must have the Ameren Illinois logo and phone number. See [Section 5.1, Figure 1](#).
- 4.5 If a marker or sign is found without the Ameren Illinois (AIC) logo and phone number and it cannot be immediately corrected, then follow these steps:
 - 4.5.1 Document in Click Mobile as "Pipeline Marker / Signage Issue".
 - 4.5.2 Replace marker or sign within 30 days.

5.0 Line Marker Warning

UNCONTROLLED IF PRINTED

5.1 Pipeline markers shall have the following warning message written legibly on a background of a sharply contrasting color:

5.1.1 **"Warning", "Caution" or "Danger"** followed by **"Gas Pipeline"**. Letters must be at least 1-inch high with ¼-inch stroke. See Figure 1 for an example.



Figure 1: Sample Pipeline Marker

5.1.2 Company name, **"Ameren Illinois"**

5.1.3 Company telephone number, **1-800-755-5000**.

5.1.4 One-Call contact info.

6.0 Placement

6.1 *Class 1 and Class 2 locations*: Pipeline markers and/or signs must be placed as close as practical over each buried transmission line, high pressure distribution main or distribution main, without encroaching on the integrity of the line or main, and at the following locations:

6.1.1 Public road crossings

6.1.2 Railroad crossings

6.1.3 Fence lines, where practical

6.1.4 New cathodic protection test stations, where possible

6.1.5 At locations and intervals that clearly identifies the pipeline route and readily warns the public of the presence of a buried gas pipeline.

6.1.6 AIC gas facilities, such as:

1. Storage fields

2. Odorizer stations

UNCONTROLLED IF PRINTED

3. Pipeline valve stations

- 6.2 *Class 3 and Class 4 locations*: Pipeline markers and/or signs must be placed **as close** as practical over each transmission line without encroaching on the integrity of the line, unless placement of the pipeline marker or sign is impractical.
- 6.3 *Above ground transmission lines, high pressure distribution mains and/or distribution mains*: Facilities that are accessible to the public must have pipeline markers and/or signs placed along each section.
- 6.3.1 This includes unfenced facilities such as:
1. Regulator stations
 2. Valve stations
 3. Bridge crossings
- 6.3.2 Consider installing pipeline markers at farm taps located in areas where vegetation growth may inhibit visibility.
- 6.4 *Waterway crossings and other deep ravines*: Navigable water crossings must have a **"Do Not Anchor or Dredge"** sign. See [GLOS](#) for definition of Navigable waterways.
- 6.5 *Other locations designated by the Gas Supervisor*: To reduce possibility of damage or for HCA identification.
- 6.6 *Regulator stations*: Shall be identified with pipeline markers or signs as per [REGS 2.1](#) where practical.

End of Instructions.

Operator Qualification (OQ) Required?

YES

1291 Locate Underground Pipelines

1301 Install and Maintain Pipeline Markers

1311 Inspect Pipeline Surface Conditions - Patrol Right of Way or Easement.

Appendices

NONE.

Attachments

NONE.

Compliance Requirements

49 CFR §192.707 Line markers for mains and transmission lines.

Reference Documents

NONE.

Document Rescission

PMRK 1 Pipeline Markers: Requirements, October 1, 2020

UNCONTROLLED IF PRINTED

Revision Notes

Location of Changes	Summary of Changes
Subsection 6.2	Grammatical – inserted "as close". Pipeline markers and/or signs must be placed as close as practical over each transmission line without encroaching on the integrity of the line, unless placement of the pipeline marker is impractical.

PIPELINE MARKERS

October 1, 2022

PMRK 2 Pipeline Facility Markers

1.0 Purpose

This document covers specifications, part numbers and installation instructions for approved pipeline markers.

All procedures in this document are in accordance with 49 CFR §192.707 and pipeline marker manufacturer recommendations.

2.0 Scope

This document addresses the following:

[3.0 Target Audience](#)

[4.0 Safety](#)

[5.0 Pipeline Markers \(See Appendix A\)](#)

[6.0 Pipeline Marker Signs \(See Appendix B\)](#)

Appendices

[Appendix A - Pipeline Markers](#)

[Appendix B - Pipeline Marker Signs](#)

3.0 Target Audience

- Gas Engineering
- Gas Distribution Design Specialist
- Gas Field Personnel
- Gas Supervisors
- Gas Construction Services Personnel
- Gas Storage Field Supervisor
- Gas Storage Field Personnel

4.0 Safety

- 4.1 If the location of the pipeline marker is not covered under a valid JULIE Dig Number for Ameren Illinois, call 811 to obtain a valid dig number before installing the pipeline marker(s).

5.0 Pipeline Markers (See [Appendix A](#))

- 5.1 COTT Pipeline Markers (See [Appendix A-1](#))
- 5.2 Carsonite Pipeline Markers (See [Appendix A-2](#))
- 5.3 Rhino TriView Pipeline Markers (See [Appendix A-3](#))

6.0 Pipeline Marker Signs (See [Appendix B](#))

- 6.1 Vertical Pipeline Marker Signs (See [Appendix B-1](#))
- 6.2 Horizontal Pipeline Marker Signs (See [Appendix B-2](#))
- 6.3 Replacement Horizontal Pipeline Marker Signs (See [Appendix B-3](#))
- 6.4 Navigable Water Crossing Sign (See [Appendix B-4](#))

UNCONTROLLED IF PRINTED

End of Instructions.

Operator Qualification (OQ) Required?

YES

0981 Backfilling

1291 Locate Underground Pipelines

1341 Provide or Assure Adequate Pipeline Support During Operator Initiated Excavation Activities

Appendices

[Appendix A - Pipeline Markers](#)

[Appendix B - Pipeline Marker Signs](#)

Attachments

NONE.

Compliance Requirements

49 CFR §192.707 Line markers for mains and transmission lines.

Reference Documents

NONE.

Document Rescission

PMRK 2 Pipeline Markers: Pipeline Facility Markers, October 1, 2021

Revision Notes

Location of Changes	Summary of Changes
Appendix B-4 – River Crossing Sign	3a. - Illinois was missing - Illinois River

Appendix A - Pipeline Markers

A-1. COTT Pipeline Markers

General

- A. See [Figure 1](#) for COTT pipeline markers are approved for installation.
- B. Each COTT marker requires 2 labels, one on each side.

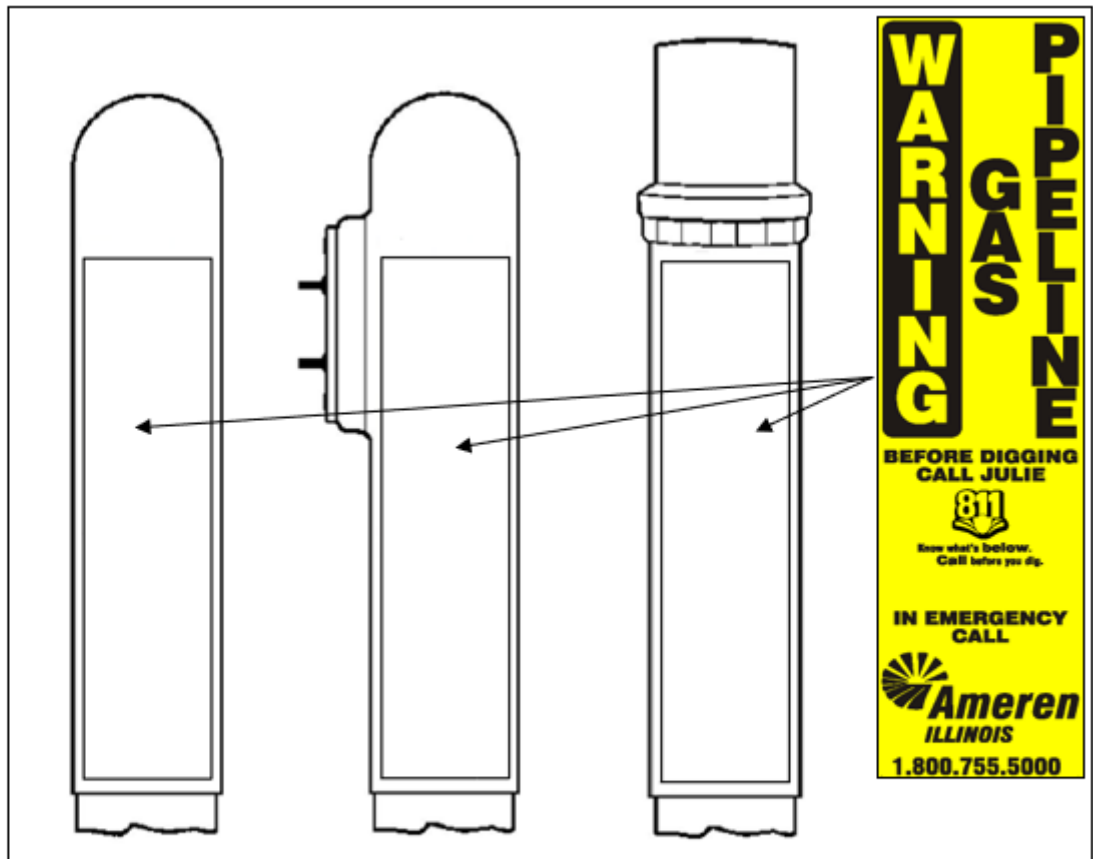

Marker Type	7-foot Marker	6-foot Marker with Finklet	6-foot Marker with Big Fink	Replacement Label (2)
Stock No.	16-02-630	16-02-628	16-02-629	16-14-049

Figure 1: COTT Pipeline Markers

Installation

1. Refer to [Figure 2](#) for typical installation of COTT marker.
2. Dig 4-1/2 inches diameter hole 2-3 feet deep.
3. If marker contains a cathodic protection test point, bring lead wire up through post and connect before installing marker.
4. Rest marker assembly on top of hole with plastic anchor in place.
5. Push marker assembly to bottom of hole.
6. Align marker straight in hole, then backfill and tamp.

In areas where the marker posts are susceptible to damage by activities such as mowing, agricultural operation or construction activities, a COTT marker can be placed over a steel post. Note that this installation method will differ from [Figure 2](#) as it will not be necessary to set the marker 2-3 feet into the ground and use the flexible plastic anchor.

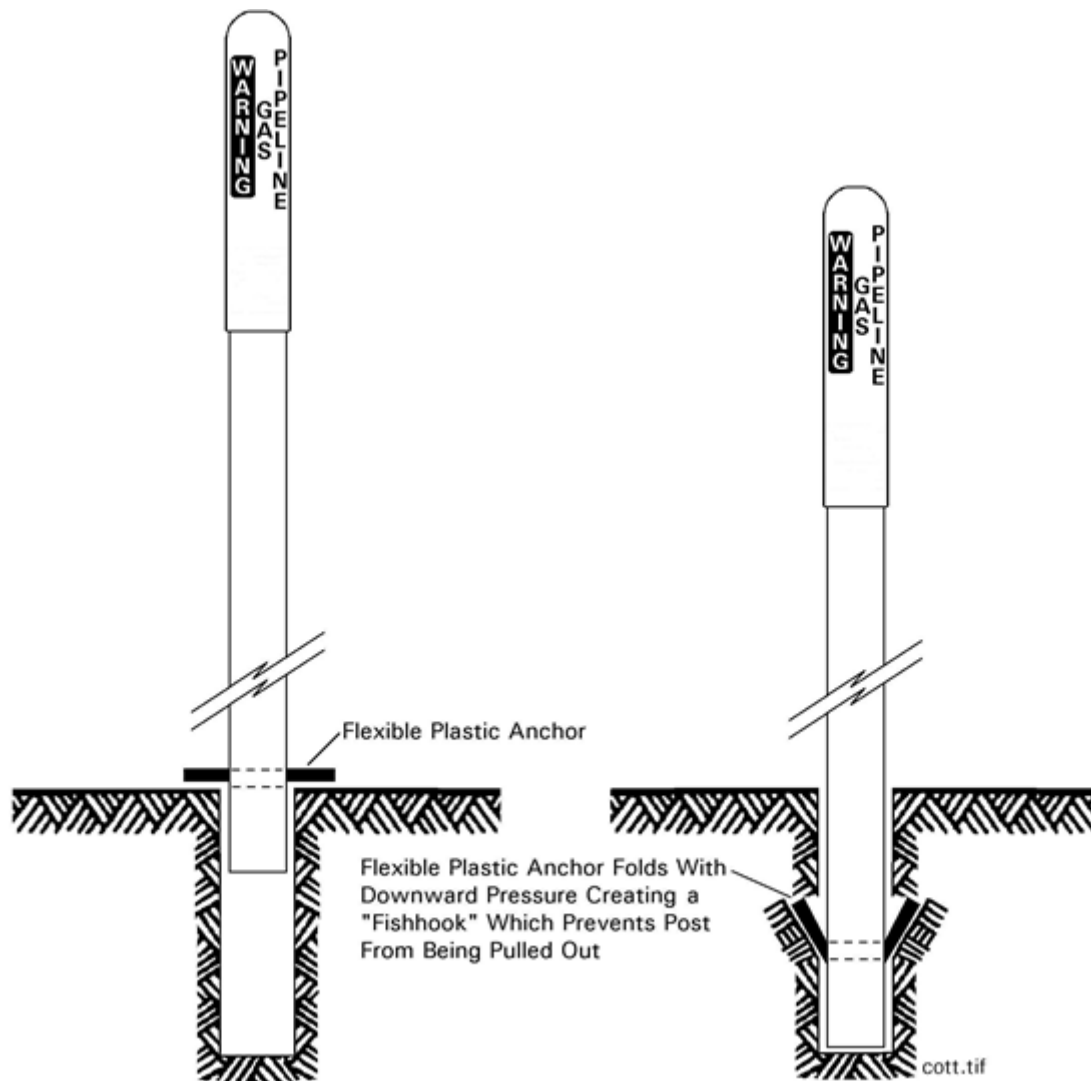
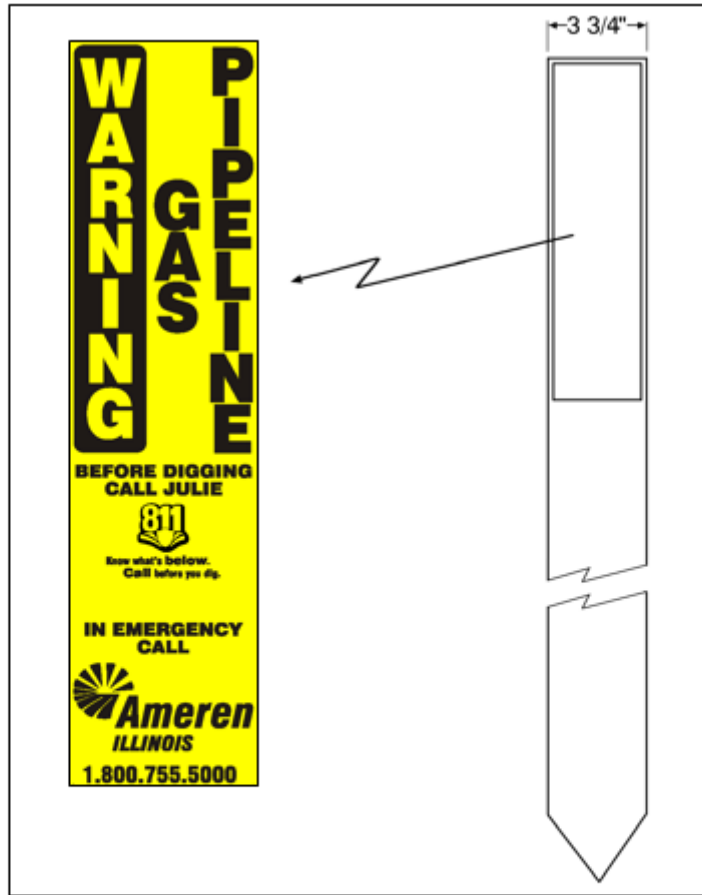

Figure 2: COTT Pipeline Marker Installation (Typical)

A-2. Carsonite Pipeline Markers

General

- A. See [Figure 3](#) for Carsonite pipeline markers are approved for installation.
- B. Each Carsonite pipeline marker requires 2 labels, one on each side.



Item	Replacement Label (2)	Carsonite Marker (78" Length)
Stock No.	16 04 993	16 04 832

Figure 3: Carsonite Pipeline Markers

Installation

1. See [Figure 4](#) and [Figure 5](#) for Carsonite pipeline marker installation.

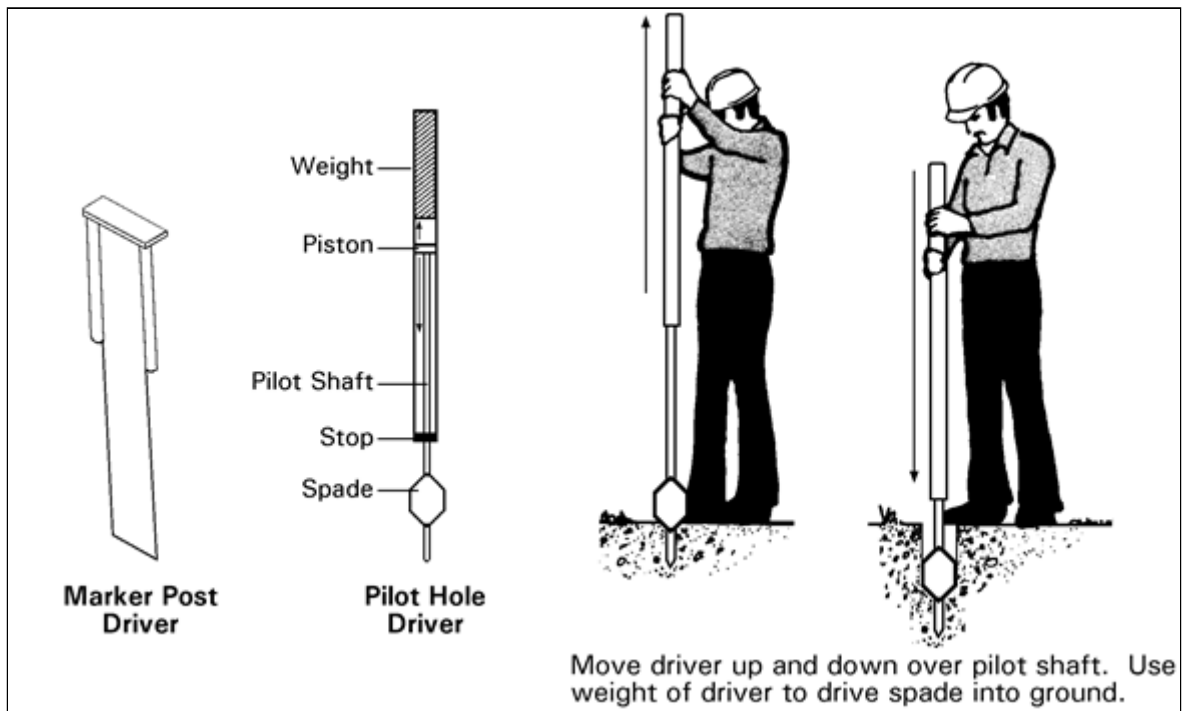

Figure 4: Pilot Hole Driver Installation

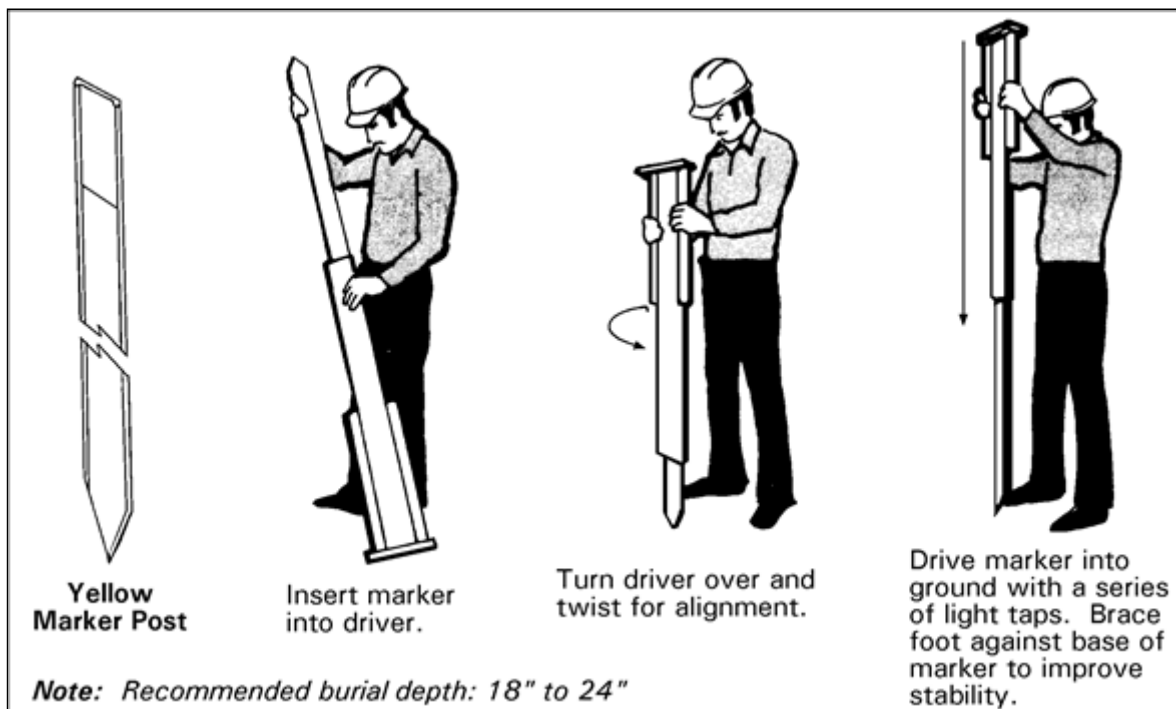

Figure 5: Pipeline Marker Post Driver Installation

A-3. Rhino TriView Pipeline Markers

General

- A. See [Figure 6](#) for Rhino TriView pipeline markers approved for installation.
 1. The basic TriView XL (formerly TriView 400) Marker is 66 inches tall.
 2. The TriView Extension is 120 inches tall, and must be used for areas with high vegetation or crops.

- B. Each Rhino pipeline marker requires 3 labels, one on each face of the triangular shaped post.

Installation

1. TriView XL (formerly TriView 400) was designed to slide over flat fiberglass but it can also be buried or placed over U-channel and round metal posts, up to 2" IPS. See [Figure 7](#) for example placement over an existing post.
 - A. TriView XL (formerly TriView 400) can be direct buried by digging an 18-inch deep hole, inserting the marker and backfilling with dirt. Marker must be straightened and soil backfill tamped frequently.



Item	Rhino TriView XL (formerly TriView 400) (66" Length)	Rhino TriView Extension (120" Length)
Stock No.	16 02 685	16 02 687

Figure 6: Rhino TriView Markers

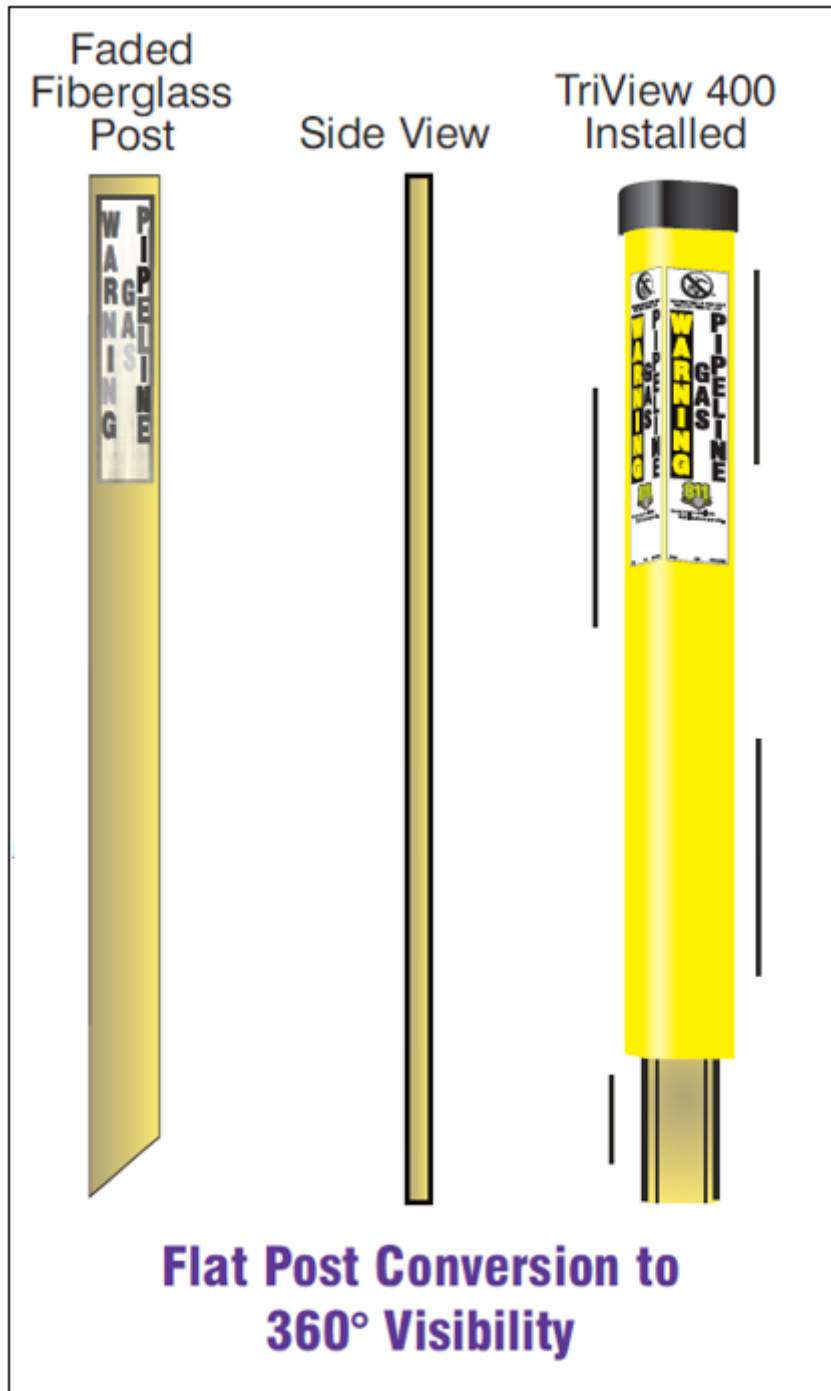

Figure 7: Rhino TriView Marker Installation over Existing Post

2. TriView Extension Marker was designed for areas where high vegetation or crops can obscure visibility or marker is susceptible to damage. See [Figure 8](#) for installation example.
 - A. Extension marker is 120 inches tall but comes in two (2) sections for ease of handling and installation.
 - B. Extension marker is designed for installation over U-channel or other metal post.
 - C. Extension marker includes mounting post and connectors.

Slide part A over a u-channel or other post and fasten at the bottom.
Then fit part B on top and fasten in the middle.

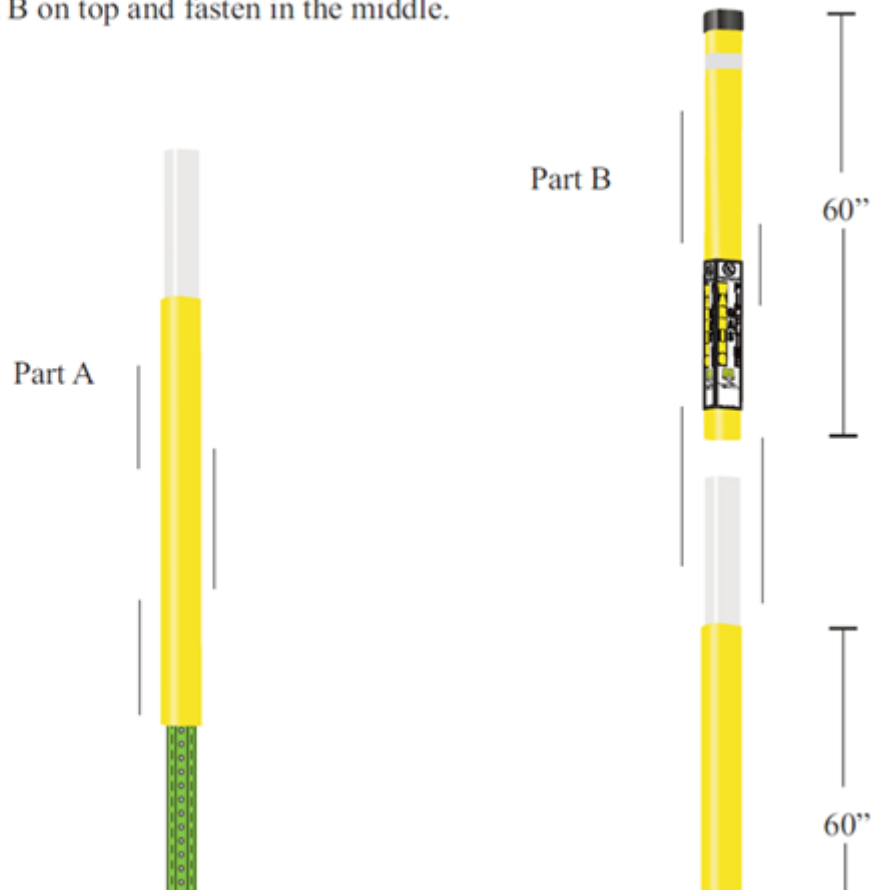

Figure 8: Rhino TriView Extension Marker Installation

Appendix B - Pipeline Marker Signs

General

1. See [Figure 9](#) for vertical pipeline marker signs and [Figure 10](#) and [Figure 11](#) for horizontal pipeline marker signs that can be used instead of Carsonite, COTT or Rhino pipeline markers to mark natural gas pipeline presence.
2. Pipeline marker signs can be attached to a steel post.

B-1. Vertical Pipeline Marker Signs

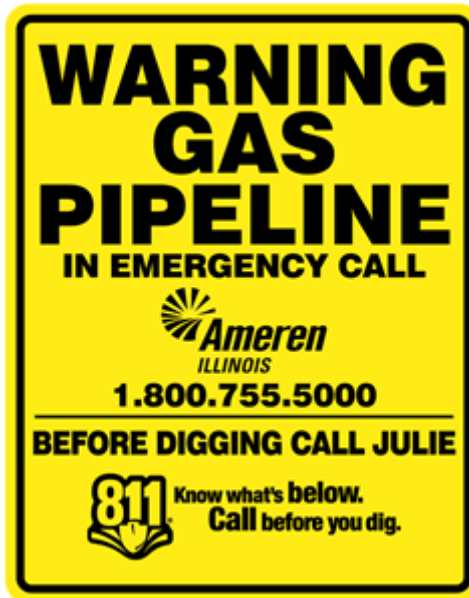

Item	Vertical Pipeline Marker Sign (10" H x 8" W)
Stock No.	16 02 409

Figure 9: Vertical Pipeline Marker Sign

B-2. Horizontal Pipeline Marker Signs



Item	Horizontal Pipeline Marker Sign (10" H x 14" W)
Stock No.	16 02 605

Figure 10: Horizontal Pipeline Marker Sign

B-3. Replacement Horizontal Pipeline Marker Signs

1. Pipeline marker sign shown above in [Appendix B-2](#) is valid until existing supply is depleted and existing signs need replacement.



Item	Replacement Horizontal Pipeline Marker Sign (10" H x 14" W)
Stock No.	16 02 700

Figure 11: Replacement Horizontal Pipeline Marker Sign

B-4. Navigable Water Crossing Sign: (Stock Code 16 02 606)

1. Sign is to be installed so that it is readable from the waterway and will be installed on both sides of the channel if required by the governing agency.
2. Existing signs remain valid until they are replaced by this new sign.
3. Navigable waterways in Illinois are:
 - a. Illinois River
 - b. Mississippi
 - c. Lower portion of Kaskaskia River

Sign – 96" x 48"



- a. Aluminum sign panel.
- b. Mounting holes are drilled during the installation process.

5. Mounting Kit

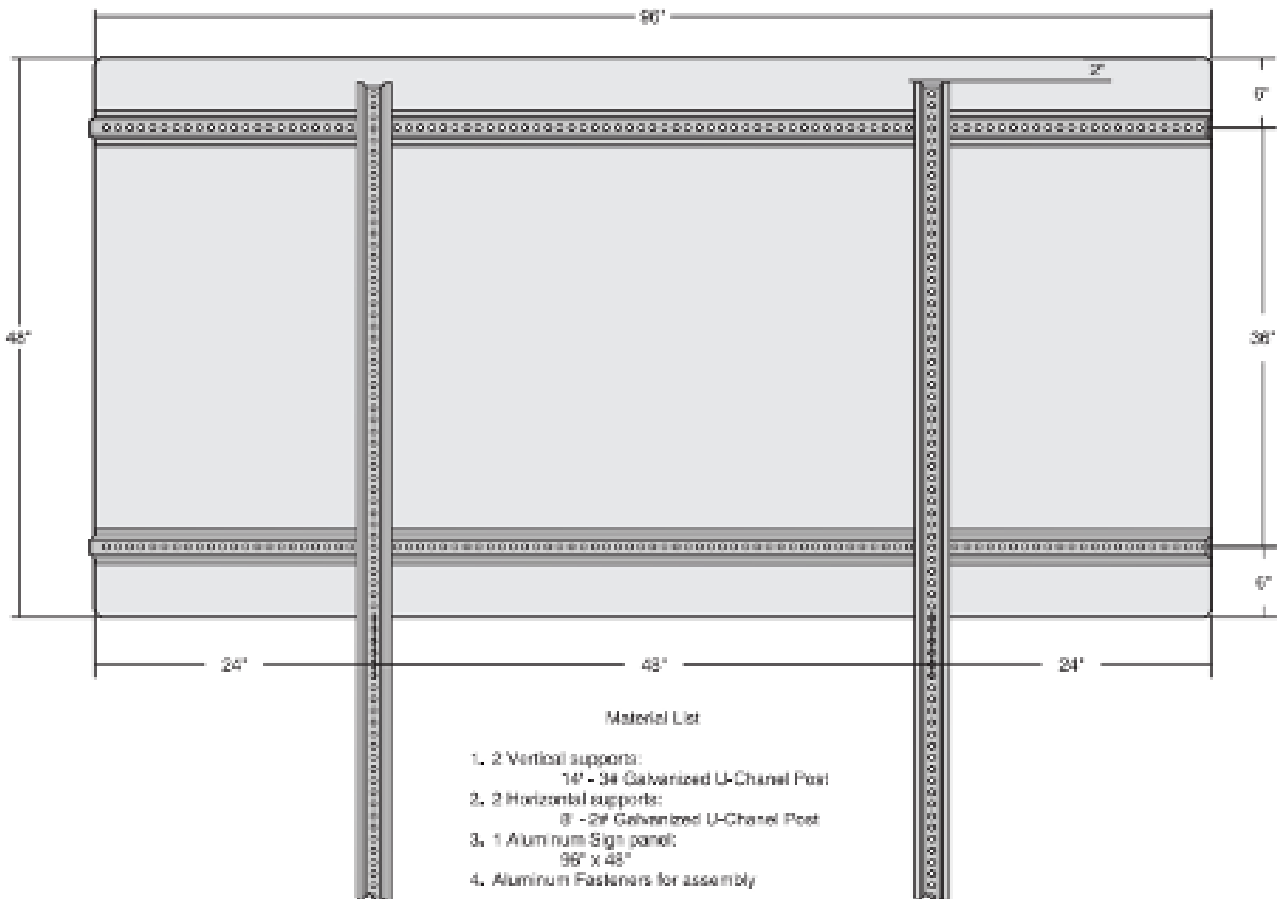

UNCONTROLLED IF PRINTED

- a. Two vertical supports: 14 feet long, 3# Galvanized U-Channel Post
- b. Two horizontal supports: 8 feet long, 2# Galvanized U-Channel Post
- c. Assembly Kit
 - i.) Two 96 inch zee bars
 - ii.) Four sets of U-Channel to zee bar hardware
 - iii.) Sixteen sets of mounting hardware
- d. Gas Tech Engineering will provide information on foundation requirement for the vertical supports

6. Mounting holes drill pattern

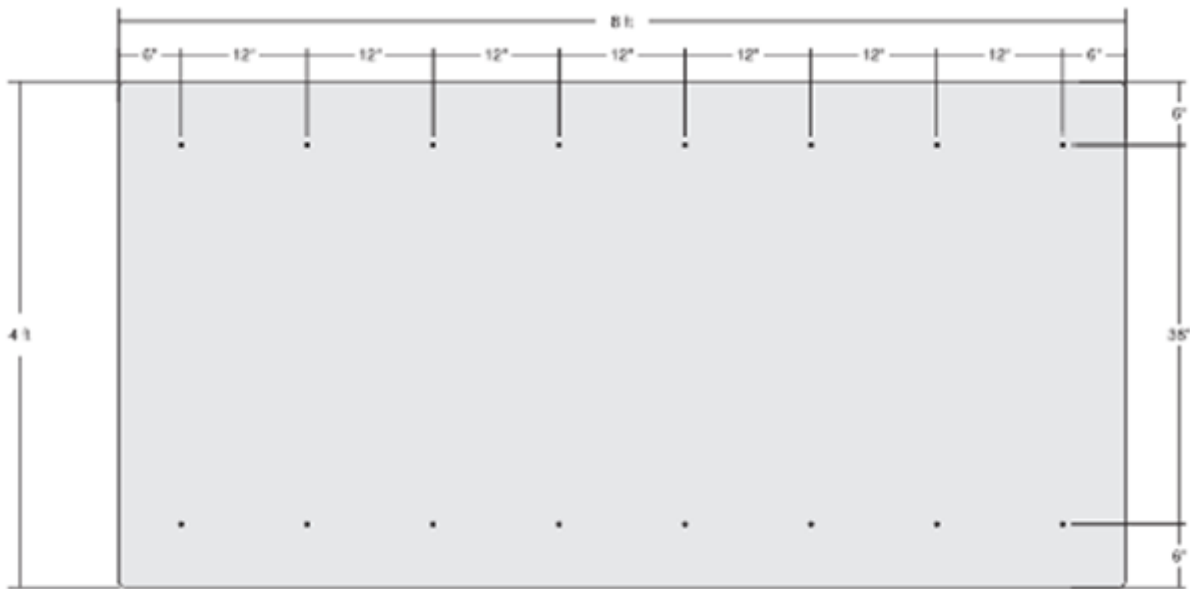

- a. Four corner holes are located approximately six inches from each edge of the sign.
- b. Top and bottom row of holes are approximately twelve inches apart.

POLY-Polyethylene Pipe

POLYETHYLENE PIPE

October 1, 2020

POLY 0 Table of Contents

[POLY 1 Polyethylene Pipe: Requirements](#)

- Section 1.0 Purpose
- Section 2.0 Scope
- Section 3.0 Target Audience
- Section 4.0 Design Criteria
- Section 5.0 Installation
- Section 6.0 Storage and Handling
- Section 7.0 Joining
- Section 8.0 Squeeze-Off
- Section 9.0 Metal Alloy Fittings
- Operator Qualification
- Compliance Requirements
- Reference Documents
- Document Rescission

[POLY 2.1 Polyethylene Pipe: Design Pressure](#)

- Section 1.0 Purpose
- Section 2.0 Scope
- Section 3.0 Target Audience
- Section 4.0 Design Pressure
- Section 5.0 Hydrostatic Design Basis
- Section 6.0 MAOP Limitations for PE Pipe
- Operator Qualification
- Appendices
 - Appendix A - Stock Coded PE Pipe
- Compliance Requirements
- Reference Documents
- Document Rescission

[POLY 2.2 Polyethylene Pipe: Squeeze Off](#)

UNCONTROLLED IF PRINTED

- Section 1.0 Purpose
- Section 2.0 Scope
- Section 3.0 Target Audience
- Section 4.0 General
- Section 5.0 Operation
- Section 6.0 Above Grade Squeeze
- Operator Qualification
- Compliance Requirements
- Reference Documents
- Document Rescission

POLY 2.3 Polyethylene Pipe: Installation Requirements

- Section 1.0 Purpose
- Section 2.0 Scope
- Section 3.0 Target Audience
- Section 4.0 General
- Section 5.0 Jobsite Handling
- Section 6.0 Support (49 CFR §192.321)
- Section 7.0 Clearances from Thermal Sources (49 CFR §192.325 (c))
- Section 8.0 Thermal Expansion and Contraction
- Section 9.0 Minimum Bending Radius
- Section 10.0 Weak Link (49 CFR §§ 192.329 (b) and 192.376 (b))
- Section 11.0 Tracer Wire
- Section 12.0 Damage During Construction
- Section 13.0 Buried Pipe Examination
- Operator Qualification
- Compliance Requirements
- Reference Documents
- Document Rescission

POLY 2.4 Polyethylene Pipe: Butt Fusion

- Section 1.0 Purpose
- Section 2.0 Scope
- Section 3.0 Target Audience
- Section 4.0 Definitions
- Section 5.0 General
- Section 6.0 Safety - Before Starting Fusion Operation

UNCONTROLLED IF PRINTED

Section 7.0 Adverse Weather Conditions

Section 8.0 Joint Assembly

Section 9.0 Hydraulic Machine Fusion

Operator Qualification

Appendices

Appendix A - Butt Fusion Fittings

Compliance Requirements

Reference Documents

Document Rescission

POLY 2.5 Polyethylene Pipe: Electrofusion

Section 1.0 Purpose

Section 2.0 Scope

Section 3.0 Target Audience

Section 4.0 Common Requirements

Section 5.0 Safety - Before Starting Fusion Operation

Section 6.0 Electrical Equipment Requirements

Section 7.0 Out of Roundness

Section 8.0 Pipe Surface Preparation

Section 9.0 Peeling

Section 10.0 Joint Assembly

Section 11.0 Electrofusion Tapping Tee Repair Kit Instructions

Section 12.0 Fusion

Section 13.0 Pressure Testing

Section 14.0 Re-Fusing

Section 15.0 Tapping

Operator Qualification

Appendices

Appendix A - Electrofusion Fittings

Appendix B - Manufacturer Cooling Times

Compliance Requirements

Reference Documents

Document Rescission

POLY 2.6 Polyethylene Pipe: Mechanical Joining

Section 1.0 Purpose

Section 2.0 Scope

UNCONTROLLED IF PRINTED

Section 3.0 Target Audience

Section 4.0 General

Section 5.0 Stab Fittings

Section 6.0 Perfection PERMASERT/PERMASERT 2.0

Section 7.0 Compression Fittings

Operator Qualification

Appendices

Appendix A - Stab Fittings

Compliance Requirements

Reference Documents

Document Rescission

POLY 2.7 Polyethylene Pipe: Evaluating PE Pipe Damage

Section 1.0 Purpose

Section 2.0 Scope

Section 3.0 Target Audience

Section 4.0 General

Section 5.0 Pipe Pit Gauge

Section 6.0 Maximum Defect Depth

Operator Qualification

Compliance Requirements

Reference Documents

Document Rescission

POLY 2.8 Polyethylene Pipe: Sale of Polyethylene Pipe

Section 1.0 Purpose

Section 2.0 Scope

Section 3.0 Target Audience

Section 4.0 General

Section 5.0 Requests from the Public

Section 6.0 Requests from Qualified Contractors, Other Gas Utilities or Municipals

Operator Qualification

Compliance Requirements

Reference Documents

Document Rescission

POLY 2.9 Polyethylene Pipe: Plastic Fusion Qualification

UNCONTROLLED IF PRINTED

Section 1.0 Purpose
Section 2.0 Scope
Section 3.0 Target Audience
Section 4.0 General
Section 5.0 Fusion Qualification
Section 6.0 Testing of Plastic Fusion Joints
Section 7.0 Requalification
Section 8.0 Records
Operator Qualification
Compliance Requirements
Reference Documents
Document Rescission

POLY 2.10 Polyethylene Pipe: Storage and Handling PE Material

Section 1.0 Purpose
Section 2.0 Scope
Section 3.0 Target Audience
Section 4.0 Receipt Inspection
Section 5.0 Handling
Section 6.0 Unloading
Section 7.0 Storage
Operator Qualification
Compliance Requirements
Reference Documents
Document Rescission

POLY 2.11 Polyethylene Pipe: Maintenance of Fusion Equipment

Section 1.0 Purpose
Section 2.0 Scope
Section 3.0 Target Audience
Section 4.0 Electrofusion Equipment Maintenance
Section 5.0 Butt Fusion Machine Maintenance
Section 6.0 Peelers
Section 7.0 Clamps
Operator Qualification
Compliance Requirements
Reference Documents

UNCONTROLLED IF PRINTED

Document Rescission

POLY 3.1 Polyethylene Pipe: Transition Fittings and Protective Sleeves

Section 1.0 Purpose

Section 2.0 Scope

Section 3.0 Target Audience

Section 4.0 Transition Fittings

Section 5.0 Protective Sleeves

Operator Qualification

Appendices

Appendix A - Transition Fittings

Appendix B - Protective Sleeves

Compliance Requirements

Reference Documents

Document Rescission

POLY 4 Polyethylene Pipe: Forms and Reference Materials

Forms

References

Document Rescission

End Table of Contents.

Document Rescission

POLY 0 Polyethylene Pipe: Table of Contents, October 1, 2020.

Revision Notes

Location of Changes	Summary of Changes
POLY 2.1 Section 4.0	Design Pressure replaces Design Formula

POLYETHYLENE PIPE

October 1, 2020

POLY 1 Requirements

1.0 Purpose

The purpose of this document is to prescribe the requirements for designing, installing, storing and handling, and joining polyethylene (PE) pipe for gas mains and service lines.

2.0 Scope

This document addresses the following:

[3.0 Target Audience](#)[4.0 Design Criteria](#)[5.0 Installation](#)[6.0 Storage and Handling](#)[7.0 Joining](#)[8.0 Squeeze-Off](#)[9.0 Metal Alloy Fittings](#)

3.0 Target Audience

- Gas Engineering
- Gas Distribution Design Specialist
- Field Engineering Representatives
- Gas Field Personnel
- Gas Supervisors
- Gas Construction Services Personnel

4.0 Design Criteria

4.1 For PE pipe design criteria and stock coded PE pipe tables, see [POLY 2.1](#) Design Pressure.

5.0 Installation

- 5.1 PE pipe shall be inspected for external damage before it is installed.
- 5.2 For PE pipe installation requirements, see [POLY 2.3](#) Installation Requirements.

6.0 Storage and Handling

- 6.1 Improper handling or installation of PE material can damage piping, compromise system performance, and result in injury. Always unload and handle PE material with proper handling procedures and equipment.
- 6.2 For specific handling and storage requirements, see [POLY 2.10](#) Storage and Handling PE Material.

7.0 Joining

- 7.1 PE pipe shall only be joined by butt fusion ([POLY 2.4](#)) or electrofusion ([POLY 2.5](#)), with the exceptions shown below:
- 7.1.1 Mechanical joining is permitted for PE pipe 1 inch and smaller. See [POLY 2.6](#) for acceptable installations.

8.0 Squeeze-Off

8.1 For PE pipe squeeze-off procedures, see [POLY 2.2](#) Squeeze Off.

9.0 Metal Alloy Fittings

9.1 As a practice, Ameren (AIC) does not install electrically isolated metal alloy fittings in plastic pipeline systems.

9.2 If it is necessary to install an electrically isolated metal alloy fitting, Corrosion Control personnel shall be contacted before installing the fitting. See [CORR 1 Paragraph 7.4.1](#). Requirements for Cathodic Protection of New and Replaced Pipeline Facilities.

End of Instructions.

Operator Qualification (OQ) Required?

YES

0641: Visually Inspect Pipe and Components Prior to Installation

0901: Installation of Plastic Pipe in a Ditch

0911: Installation of Plastic Pipe in a Bore

0921: Installation of Plastic Pipe Plowing/Pull-in

0931: Installation of Plastic Pipe in Plowing/Planting

Appendices

NONE.

Attachments

NONE.

Compliance Requirements

49 CFR §192.59 Plastic pipe.

49 CFR §192.321 Installation of plastic pipe.

Reference Documents

[CORR 1 Corrosion Control: Requirements](#)

[POLY 2.1 Polyethylene Pipe: Design Pressure](#)

[POLY 2.2 Polyethylene Pipe: Squeeze Off](#)

[POLY 2.3 Polyethylene Pipe: Installation Requirements](#)

[POLY 2.4 Polyethylene Pipe: Butt Fusion](#)

[POLY 2.5 Polyethylene Pipe: Electrofusion](#)

[POLY 2.6 Polyethylene Pipe: Mechanical Joining](#)

[POLY 2.10 Polyethylene Pipe: Storage and Handling PE Material](#)

Document Rescission

POLY 1 Polyethylene Pipe: Requirements, October 1, 2019.

UNCONTROLLED IF PRINTED

Revision Notes

Location of Changes	Summary of Changes
Not applicable.	This is a new document.

POLYETHYLENE PIPE

April 1, 2023

POLY 2.1 Design Pressure**1.0 Purpose**

This document provides the design formula, design parameters and typical values applicable to plastic pipe design, in accordance with 49 CFR §192.121.

2.0 Scope

This document addresses the following:

[3.0 Target Audience](#)[4.0 Design Pressure](#)[5.0 Hydrostatic Design Basis](#)[6.0 MAOP Limitations for PE Pipe](#)

Appendices

[Appendix A - Stock Coded PE Pipe](#)**3.0 Target Audience**

- Gas Engineering
- Gas Distribution Design Specialist
- Field Engineering Representatives
- Gas Field Personnel
- Gas Supervisors
- Gas Construction Services Personnel

4.0 Design Pressure

4.1 The design pressure for plastic pipe is determined in accordance with either of the following formulas:

$$P = 2S \frac{t}{(D-t)} 0.32 \quad \text{OR} \quad P = \frac{2S}{(SDR-1)} 0.32$$

NOTE:

For CTS pipe use: $P = 2S (t/(D-t)) (DF)$ formula.
CTS pipe does not have a published SDR value.

where

P = Design pressure (psi)

S = Hydrostatic Design Basis (HDB) (psi) (see [5.1](#) below)

t = Wall thickness (inches)

D = Outside diameter (inches)

SDR = Standard Dimension Ratio (Nominal Outside Diameter / Minimum Wall Thickness)

4.2 Ameren Illinois (AIC) used the DF= 0.32 (§192.121) for all PE pipe installations prior to October 1, 2021.

4.3 PE 4710 pipe installation on or after October 1, 2021, a DF = 0.40 can be used as long as:

UNCONTROLLED IF PRINTED

- 4.3.1 The Design Pressure does not exceed 125 psig,
 - 4.3.2 The pipe designation is PE 4710,
 - 4.3.3 The pipe has a nominal size of 24 inches IPS or less, and
 - 4.3.4 The pipe was manufactured on or after January 22, 2019.
 - 4.3.5 AIC's PE 4710 pipe meets or exceeds the minimum wall thickness required for a DF = 0.40
- 4.4 The Design Pressure for AIC's PE 2708 pipe installation shall continue to use a DF = 0.32 and a maximum Design MAOP of 60 psig.

MAOP of a PE pipe segment or system must be established prior to placing the segment or system into service. PE pipe system's MAOP cannot be updated without taking the system or segment out of service and then testing.

5.0 Hydrostatic Design Basis

- 5.1 The following Hydrostatic Design Basis (HDB) values shall be used when calculating the design pressure for Performance Pipe's DriscoPlex 6500 Series PE 2708 and DRISCOPIPE 8300 Series PE 4710.

Table 1: HDB Values

Design Temperature (°F)	HDB Value (psi)	
	DriscoPlex 6500 Series PE 2708	DRISCOPIPE 8300 Series PE 4710
73°	1250	1600
100°	1000	1250
120°	1000	1000
140°	800	1000

- 5.2 The following design temperatures shall be used when determining which HDB value (S) value to use in the Design Pressure.

Hydrostatic Design Basis (S) for plastic pipe is **not** the same quantity as Yield Strength (S) for steel pipe.

Table 2: Design Temperatures for HDB Value

Nominal Pipe Size (inches)	Design Temperature (°F)	Notes
½" CTS	120°	Use 120°F temperature due to service line riser exposure to sun.
1" CTS	120°	
1 ¼" IPS	120°	
2" IPS	120°	

2" IPS	73°	Use 73°F temperature for buried gas pipe with short term above ground or uncovered exposure during testing.
3" IPS	73°	
4" IPS	73°	
6" IPS	73°	
8" IPS	73°	
12" IPS	73°	

5.3 [Appendix A](#) provides the values for wall thickness (t), outside diameter (D) and the SDR for the PE pipe stock coded at Ameren Illinois (AIC).

6.0 MAOP Limitations for PE Pipe

6.1 The MAOP for all PE 2708 mains and service lines shall be limited to 60 psig.

6.2 The MAOP for all PE 4710 mains and service lines installed prior to October 1, 2021 shall be limited to 100 psig.

6.3 The MAOP for PE 4710 main and services lines installed on or after October 1, 2021 shall be limited to a maximum of 125 psig.

End of Instructions.

Operator Qualification (OQ) Required?

NONE.

Appendices

[Appendix A - Stock Coded PE Pipe](#)

Attachments

NONE.

Compliance Requirements

49 CFR §192.121 Design of plastic pipe.

Reference Documents

NONE.

Document Rescission

POLY 2.1 Polyethylene Pipe: Design Pressure, October 1, 2022

Revision Notes

Location of Changes	Summary of Changes
Appendix A-1 – PE2708 Pipe	Removed 1/2" CTS PE2708 pipe. AIC no longer purchasing this pipe. PE4710 pipe is used for all 1/2" CTS service lines.

Appendix A - Stock Coded PE Pipe

A-1. PE 2708 Pipe (Medium Density)

Nominal Pipe Size (inches)	SDR	Outside Diameter (inches)	Wall Thickness (inches)	Length	Stock No.
1" CTS	Equal to 11.4	1.125"	0.099"	500' Coil	32 05 003
1 ¼" IPS	10.0	1.660"	0.166"	500' Coil	32 05 004
1 ¼" IPS	10.0	1.660"	0.166"	20' Stick	32 22 023
2" IPS	11.0	2.375"	0.216"	500' Coil	32 05 001
2" IPS	11.0	2.375"	0.216"	20' Stick	32 05 024
3" IPS	11.5	3.500"	0.304"	40' Stick	32 05 016
4" IPS	11.5	4.500"	0.391"	500' Coil	32 05 033
4" IPS	11.5	4.500"	0.391"	40' Stick	32 05 008
6" IPS	11.5	6.625"	0.576"	500' Coil	32 05 034
6" IPS	11.5	6.625"	0.576"	40' Stick	32 05 017
8" IPS	13.5	8.625"	0.639"	40' Stick	32 05 018

Notes:

1. CTS pipe print line contains the minimum wall thickness. It does not show a SDR rating. The SDR shown in this table is a calculated equivalent SDR.
2. 1 ¼" PE 2708 is only to be used for inserting service lines and mains or the repair of existing facilities.
3. 3" PE 2708 is only to be used for main insertions or the repair of existing facilities.
4. PE 2708 risers are the same SDR as the pipe.

A-2. PE 4710 Pipe (High Density)

Nominal Pipe Size (inches)	SDR	Outside Diameter (inches)	Wall Thickness (inches)	Length	Stock No.
½" CTS	Equal to 7.0	0.625"	0.090"	500' Coil	32 22 018
1" CTS	Equal to 11.1	1.125"	0.101"	500' Coil	32 22 019
2" IPS	11.0	2.375"	0.216"	500' Coil	32 22 020
2" IPS	11.0	2.375"	0.216"	40' Stick	32 22 031
4" IPS	11.0	4.500"	0.409"	40' Stick	32 22 021
4" IPS	11.0	4.500"	0.409"	500' Coil	32-05-042

UNCONTROLLED IF PRINTED

6" IPS	11.0	6.625"	0.602"	40' Stick	32 22 022
8" IPS	11.0	8.625"	0.784"	40' Stick	32 05 047
12" IPS	11.0	12.750"	1.159"	40' Stick	32 05 049

Notes:

1. CTS pipe print line contains the minimum wall thickness. It does not show a SDR rating. The SDR shown in this table is a calculated equivalent SDR.
2. PE 4710 services, 1/2" CTS, 1" CTS and 2" IPS require a SDR 7.0 riser.
3. Use SDR 7.0 with Design Temperature of 120°F to calculate maximum design pressure for 1/2" CTS, 1" CTS and 2" IPS PE 4710 service line pipe.

POLYETHYLENE PIPE

April 1, 2023

POLY 2.2 Squeeze Off

1.0 Purpose

This document prescribes the requirements for squeezing off polyethylene (PE) pipe.

2.0 Scope

This document addresses the following:

[3.0 Target Audience](#)[4.0 General](#)[5.0 Operation](#)[6.0 Above Grade Squeeze](#)

3.0 Target Audience

- Gas Engineering
- Gas Supervisors
- Gas Field Personnel
- Gas Construction Services Personnel

4.0 General

- 4.1 Gas flow in PE pipe can be controlled by squeezing the pipe with a squeeze off tool marked ASTM F1563 or is certified as complying with ASTM F1563.

ASTM F1563 is Standard Specification for Tools to Squeeze-off PE Gas Pipe.

- 4.2 Before squeezing a line, refer to [PRES 2.1](#) Potential Over Pressurization or Service Interruption.
- 4.3 All squeeze-off tools are required to be grounded when squeezing PE pipe.
- 4.4 Squeeze-off tool manufacturer's information is in [POLY 4](#) Reference Materials.

5.0 Operation

Over-squeezing and excessive squeeze-off time will damage the PE pipe.

- 5.1 Before Starting Squeeze-Off

- 5.1.1 Keep squeeze tools in good working order and examine before each use. The tool shall have the proper diameter squeeze bar and pipe gap stops for the size of pipe being squeezed.

1. **Do not** use squeeze tools without the proper pipe gap stops.

- 2. Hydraulic squeeze tools shall have locks to prevent accidental release.
- 5.1.2 Inspect the pipe for damage and clean the area where the squeeze is to be made.
 - 1. **Do not** squeeze if there is a scratch deeper than 10% of wall thickness.
 - 2. Dirt or grit in the squeezing area can damage the pipe.
- 5.1.3 Prevent the build-up of static electricity charge in PE pipe by:
 - 1. Grounding the squeezing tool, AND
 - 2. Spraying the 1-1/4 inch and larger pipe with Ionix Static Suppressor, **low temperature formula (-20°F) (49 22 507)** or wrapping the pipe with wet or soapy non-synthetic rags near the point of cutting or repairs. The rags shall be kept wet during the squeeze off.

NOTE:	When using above grade squeeze-off tool refer to Section 6.0 for the exact use of a static suppressor or wet rags.
--------------	--

5.2 Squeeze Off Tool Location and Operation

- 5.2.1 Select and set the correct squeeze bar and pipe gap stops on the squeeze tool.
- 5.2.2 Locate squeeze tool a minimum of 3 pipe diameters from: See Table 1.
 - 1. Any fusion joint, or
 - 2. Saddle fusion fitting, or
 - 3. Mechanical connection, or
 - 4. Previous squeeze off location, or
 - 5. Second squeeze tool.

NOTE:	Use blocks to support hydraulic or other heavy squeeze tools.
--------------	---

Table 1: Minimum Distance For Squeeze Tool.		
Pipe Size	Pipe OD	Minimum Distance
1/2" CTS	0.625"	1-7/8"
3/4" IPS	1.050"	3-3/16"
1" CTS	1.125"	3-3/8"
1" IPS	1.315"	4"
1-1/4" IPS	1.660"	5"
2" IPS	2.375"	7-1/8"

UNCONTROLLED IF PRINTED

3" IPS	3.500"	10-1/2"
4" IPS	4.500"	13-1/2"
6"IPS	6.625"	19-7/8"
8" IPS	8.625"	25-7/8"
10" IPS	10.750"	32-1/4"
12" IPS	12.750"	38-1/4"

5.2.3 Center the squeeze tool on and square to the pipe.

5.2.4 Operate the screw operated or hydraulic operated tool in a slow continuous manner, with a compression rate of approximately 2 inches per minute based on the pipe's outside diameter, to allow stress relaxation in the pipe. See Table 2 – Approximate Squeeze-off and Release Times.

NOTE:	If air temperatures is below freezing, squeeze rate should be slowed to approximately 1 in per minute of pipe's outside diameter.
--------------	---

Table 2 - Approximate Squeeze-off and Release Times

Pipe Size (inches)	Pipe OD (inches)	Approximate Squeeze-Off Time	Approximate Release Time
1/2 CTS	0.625	20 seconds	75 seconds
3/4 IPS	1.050	32 seconds	2 minutes 6 seconds
1 CTS	1.125	34 seconds	2 minutes 15 seconds
1 IPS	1.315	40 Seconds	2 minutes 38 seconds
1-1/4 IPS	1.660	50 seconds	3 minutes 20 seconds
2 IPS	2.375	1 minute 12 seconds	4 minutes 45 seconds
3 IPS	3.500	1 minute 45 seconds	7 minutes
4 IPS	4.500	2 minute 15 seconds	9 minutes
6 IPS	6.625	3 minute 20 seconds	13 minutes 15 seconds
8 IPS	8.625	4 minute 20 seconds	17 minutes 15 seconds
10 IPS	10.750	5 minute 25 seconds	21 minutes 30 seconds
12 IPS	12.750	6 minute 25 seconds	51 minutes

1. **Do not** over-squeeze the pipe.
 - 1 a. The correct stops limit the minimum gap to 70% times twice the wall thickness of the PE pipe for screw and hydraulic operated squeeze-off tool.
 - 1 b. The 1" CTS PE 2708 pipe requires a pipe gap stop for 0.099 inches wall thickness.
 - 1 c. The 1" CTS PE 4710 pipe requires a pipe gap stop for 0.101 inches wall thickness.

5.2.5 Operate the hand squeeze tool for PE pipe 2 inches or smaller in accordance with manufacturer's instructions.

1. The correct stops limit the minimum gap to 85% times twice the wall thickness of the PE pipe for a hand squeeze-off tool such as a Timberline TC1-S.

The wall thickness of the 1" CTS PE 2708 is thinner than the wall thickness of the PE 4710 pipe, requiring a different squeezer or different gap stop setting.

1" PE 2708 requires a squeezer marked: wall thickness of 0.099".

1" PE 4710 requires a squeezer marked: wall thickness of 0.101".

The wall thickness of the other PE pipe sizes is the same for PE 2708 and PE 4710. Refer to [POLY 2.1 Appendix A](#).

5.2.6 If 100% shut-off is required, it may be necessary to install a second at least 3 pipe diameters from the first squeezer.

1. **Do not** remove or alter the gap stops, or place anything (rags, sticks, etc.) between the squeeze bars and the pipe.

5.2.7 **Do not** leave squeeze off tools on the pipe for more than 8 hours. Excessive squeeze off time may damage the pipe.

5.3 Squeeze Off Tool Removal

5.3.1 When placing pipe back in service, slowly release the screw operated or hydraulic operated squeezer at approximately 0.5 inches per minute of the pipe's outside diameter to allow the pipe to relax.

1. If air temperature is below freezing, release rate should be slowed to approximately 0.25 inches per minute.

5.3.2 Hand squeeze tool shall be released in accordance with the manufacturer's instructions.

5.3.3 After removing the squeeze tool:

1. Examine the pipe surface for evidence of damage.
2. Check for possible leaks.
3. If there are any leaks, cracks, cuts or other indications of damage in the squeeze area, then cut out and replace the damaged section. Refer to [REPR 1 Section 9.0](#) Polyethylene (PE) Pipe Repair.

5.3.3 If necessary, the pipe may be re-rounded.

1. After the tool has been completely opened, rotate the tool 90° on the pipe.
2. Slowly re-round the pipe by partially closing the tool until the pipe is circular.
3. It may be necessary to close the tool somewhat past circular, so that the pipe is round when the tool is again released.
4. The re-rounding closure rate should not exceed the closure rate.
5. The pipe should not be completely flattened.

UNCONTROLLED IF PRINTED

- 5.3.4 After removing the squeeze tool, identify the squeeze off location by wrapping the pipe with electrical tape. **Do not** squeeze off the pipe again at that location.

6.0 Above Grade Squeeze

- 6.1 PE pipe can be squeezed, without requiring gas field personnel to enter the excavation, by using a long handle squeeze tool with gap stops specific for the size of pipe and wall thickness to be squeezed.
- 6.2 Since personnel are not entering the excavation to apply the squeezer, cleaning and applying Ionix Static Suppressor to eliminate static charge of the pipe are not required.
- 6.3 The squeeze off tool shall be grounded.
- 6.4 If the squeeze off is to be performed in a hazardous gas environment, gas field personnel should follow procedures in [WIGE 2.1](#) Hazardous Environment.

End of Instructions.

Operator Qualification (OQ) Required?

YES

1141: Squeeze Off Plastic Pipe

Appendices

NONE.

Attachments

NONE.

Compliance Requirements

49 CFR §192.281 Plastic pipe.

Reference Documents

[PRES 2.1 Pressure Monitoring: Potential Over Pressurization or Service Interruption](#)

[WIGE 2.1 Working In Gaseous Environment: Hazardous Environment](#)

Plastics Pipe Institute: "PE Pipe Squeeze-Off Compression & Release Times" Table – See [POLY 4 - PPI - TN 54 - 2017](#)

Performance Pipe PP801-TN Squeeze-Off – See [POLY 4](#)

ASTM F1563 – Standard Specification for Squeeze-Off Tools

Document Rescission

POLY 2.2 Polyethylene Pipe: Squeeze Off, October 1, 2022

Revision Notes

Location of Changes	Summary of Changes
---------------------	--------------------

UNCONTROLLED IF PRINTED

Subsection 5.1	Grammatical – added hyphen – Squeeze-Off
Paragraph 5.1.3, Item 2	AIC now purchasing the low temperature formula (-20°F) Ionix Static Suppressor stock code 49 22 507. Cancelling the standard formula Ionix spray..
Paragraph 5.1.3, Item 2.	Added – NOTE: When using above grade squeeze-off tool refer to Section 6.0 for the exception on the use of a static suppressor or wet rags.
Paragraph 5.2.2 Table 1 – Minimum Distance for Squeeze Tool	Fractions for minimum distance calculated based on 3 times the pipe outside diameter.

POLYETHYLENE PIPE

October 1, 2021

POLY 2.3 Installation Requirements

1.0 Purpose

The purpose of this document is to prescribe the requirements for installing polyethylene (PE) pipe for gas mains and service lines.

2.0 Scope

This document addresses the following:

[3.0 Target Audience](#)[4.0 General](#)[5.0 Jobsite Handling](#)[6.0 Support \(49 CFR §192.321\)](#)[7.0 Clearances from Thermal Sources \(49 CFR §192.325 \(c\)\)](#)[8.0 Thermal Expansion and Contraction](#)[9.0 Minimum Bending Radius](#)[10.0 Weak Link \(49 CFR §§ 192.329 \(b\) and 192.376 \(b\)\)](#)[11.0 Tracer Wire](#)[12.0 Damage During Construction](#)[13.0 Buried Pipe Examination](#)**3.0 Target Audience**

- Gas Engineering
- Gas Distribution Design Specialist
- Field Engineering Representatives
- Gas Field Personnel
- Gas Supervisors
- Gas Construction Services Personnel

4.0 General

- 4.1 PE pipe shall be inspected for external damage before it is installed.
- 4.2 For additional construction requirements, see the [MAIN](#) and [SERV](#) sections of the O&M Plan.

5.0 Jobsite Handling

- 5.1 Check the print line on the pipe.
 - 5.1.1 If the print line is not legible, the pipe shall not be installed.
 - 5.1.2 PE 2708 (MDPE) shall be installed within 3 years from the manufactured date printed on the pipe.
 - 5.1.3 PE 4710 (HDPE) shall be installed within 10 years from the manufactured date printed on the pipe.
- 5.2 Coils of PE pipe may be sequence banded to permit controlled uncoiling of pipe.

UNCONTROLLED IF PRINTED

- 5.3 Do not cut all bands at once and extra precautions shall be taken when cutting the final band.
- 5.4 When installing 4 inch and larger coiled pipe:
 - 5.4.1 The pipe shall be run through straightening and re-rounding equipment as the pipe is being removed from the pipe trailer. See [POLY 4](#) for McElroy Line Tamer instructions.
 - 5.4.2 Anchor or restrain the ends of the pipe to prevent them from spring back.
 - 5.4.3 Straighten and re-rounding equipment do not recommend installing 4 inch and larger coiled pipe when the temperature is below 32° F for an extended period of time.
 - 5.4.4 Stick pipe 4 inch and larger should be considered when extended temperatures are below 32° F.

6.0 Support (49 CFR §192.321)

- 6.1 For permanent installation, PE pipe shall be installed below ground.
- 6.2 PE pipe shall be installed so as to minimize shear and tensile stresses.
 - 6.2.1 Whenever PE pipe is exposed, consider providing support to minimize stresses due to excessive sagging.
- 6.3 Protective sleeves shall be installed on the outlet of service tees in accordance with [SERV 1 Appendix B](#) and on steel-to-plastic transition fittings in accordance with [MAIN 3.1](#) and [MAIN 3.2](#). See [POLY 3.1](#) for protective sleeves and transition fittings.

7.0 Clearances from Thermal Sources (49 CFR §192.325 (c))

Temperatures greater than 100°F can impair serviceability of PE pipe.

- 7.1 PE pipe shall be installed with sufficient clearance, or insulated, from any source of heat (e.g., steam pipes).
- 7.2 Typically, 12 inches is considered sufficient clearance.

8.0 Thermal Expansion and Contraction

- 8.1 PE pipe will expand or contract at a rate of approximately 1 inch per 1,000 feet for each degree of temperature change.
- 8.2 MDPE and HDPE pipe have the same expansion and contraction coefficients.
- 8.3 Examples:
 - 8.3.1 1,000 feet of 2 inch PE pipe, heated to 100°F in the sun, can contract 3 feet when buried in 60°F soil.
 - 8.3.2 100 feet of ½ or 1 inch PE pipe, heated to 100°F in the sun, can contract 4 inches when buried in 60°F soil. Thus, slack in the service line should be left near the service tee.
- 8.4 In order to avoid unnecessary tension stress in the pipe, consider:
 - 8.4.1 Cutting the pipe slightly longer than needed.

UNCONTROLLED IF PRINTED

8.4.2 "Snaking" the pipe in the bottom of the trench.

8.4.3 Allowing pipe to adjust to ground temperature before completing any final tie-ins.

9.0 Minimum Bending Radius

9.1 The flexibility of PE pipe lends itself to easy bends for changes in direction.

9.1.1 Bend shall have a smooth contour.

9.1.2 Bend shall have at least the minimum bending radius shown in [Table 1](#).

1. Use fittings to make changes in direction on PE pipe that has a radius smaller than the recommended minimum.
2. Butt fusion joints are **not** considered a fitting.

9.1.3 Bend shall be free of buckles, cracks, or other evidence of damage.

9.2 See [Table 1](#) and [Figure 1](#) for minimum bend radius.

9.2.1 "Pipe WITHOUT Fittings" indicates the minimum bend radius for pipe where there are no fittings present within the bend.

9.2.2 "Pipe WITH Fitting within Bend" (100 times Pipe Diameter) indicates the flatter radius required where a fitting is present or will be installed within the bend.

1. This bend radius should be maintained for a distance of about 5 pipe diameters on either side of the fitting location.

Table 1: Permanent Minimum Bend Radius

PE Pipe Size (inches)	PE Pipe OD (inches)	SDR		Permanent Minimum Bend Radius	
		MDPE	HDPE	Pipe WITHOUT Fittings (Fig. 1)	Pipe WITH Fitting within Bend (100 times Pipe OD)
½" CTS	0.625"	7	7	13"	63"
1" CTS	1.125"	11.5	11.4	28"	125"
1 1/4" IPS	1.660"	10	N/A	42"	166"
2" IPS	2.375"	11	11	59"	238"
3" IPS	3.500"	11.5	N/A	88"	350"
4" IPS	4.500"	11.5	11	113"	450"
6" IPS	6.625"	11.5	11	166"	663"
8" IPS	8.625"	13.5	11	233"	863"
12" IPS	12.750"	N/A	11	318"	1275"

Table 2: Allowable Cold Bending Radius

Pipe WITHOUT Fittings in Bend	SDR 9 or less	SDR greater than 9 and less than 13.5	SDR 13.5 or greater
		20 times pipe OD	25 times pipe OD
Pipe WITH Fitting or Flange in Bend	All SDR's - 100 times the pipe OD		

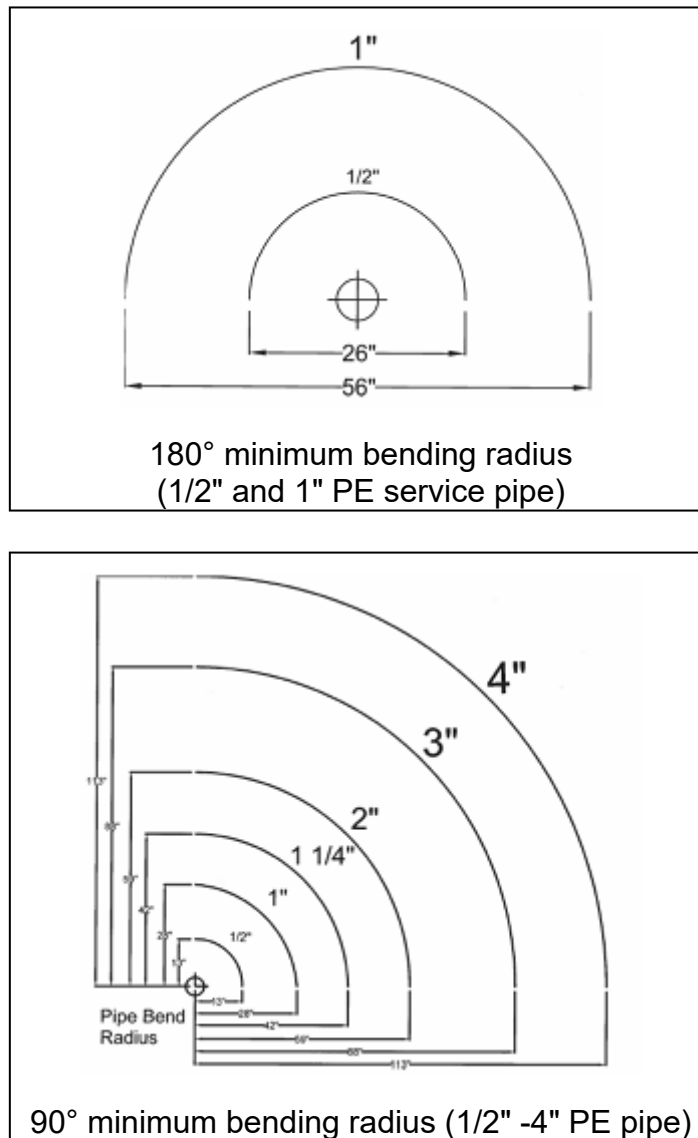

Figure 1: Permanent Minimum Pipe Bend Radius (Pipe WITHOUT Fittings)

10.0 Weak Link (49 CFR §§ 192.329 (b) and 192.376 (b))

10.1 Precautions shall be taken to ensure that the pipe is not overstressed by excessive forces when PE pipe is installed using pull-in methods for trenchless excavations such as:

10.1.1 Insertion

10.1.2 Boring

10.1.3 Plowing

10.1.4 Pulling pipe in by hand through the ground or casing.

10.2 Installation options to protect the pipe from damage include the following.

10.2.1 PE pipe sizes 1" CTS or smaller:

1. A weak link may be created by physically removing approximately 50% of the pipe wall by cutting approximately half of the diameter of the pipe.

Tape over the cut prior to pulling the pipe.

UNCONTROLLED IF PRINTED

Scoring or drilling are **not** acceptable methods for reducing wall thickness.

2. Install a commercially available manufactured weak link designed for the pipe size being installed.
3. Weak link is required when pulling pipe by hand through the ground or casing.

10.2.2 PE pipe sizes larger than 1" CTS:

1. Install commercially available manufactured weak link designed for pipe size being installed.

10.3 Cumberland Products Weak Link

10.3.1 Cumberland Projects Weak Link is designed to yield before reaching the pipe's standard safe pull strength to protect the pipe from overload.

10.3.2 The Cumberland Weak Links are stock coded and available through the MDF storeroom.

10.3.3 Contact Gas Standards & Procedures if a larger size weak link is needed.

Table is 3: Cumberland Products Weak Links - Medium Density, Yellow Plastic

Stock Code	Size	Material: Medium Density, Yellow Plastic
32 22 036	1" CTS	
32 22 037	1-¼" IPS	
32 22 038	2" IPS	
32 22 039	4" IPS	
32 22 040	6" IPS	
32 22 041	8" IPS	

Table 4: Cumberland Products Weak Links - High Density, Black Plastic

Stock Code	Size	Material: High Density, Black Plastic
39 22 642	1/2" CTS	
32 22 032	1" CTS	
32 22 033	2" IPS	
32 22 034	4" IPS	
32 22 035	6" IPS	

10.4 Condux Swivel

The swivels should not be used for applications where the link breaking could cause injury from the cable flying back.

10.4.1 A commercial break-away swivel is installed ahead of the pipe and is sized to match the pipe size as listed in [Table 3](#) and [Table 4](#).

10.4.2 The Condux swivel ([Figure 2](#)) is shown in the Gas Standards & Materials Share-Point site under [Tools & Equipment Page](#). See [POLY 4](#) for Condux manual.

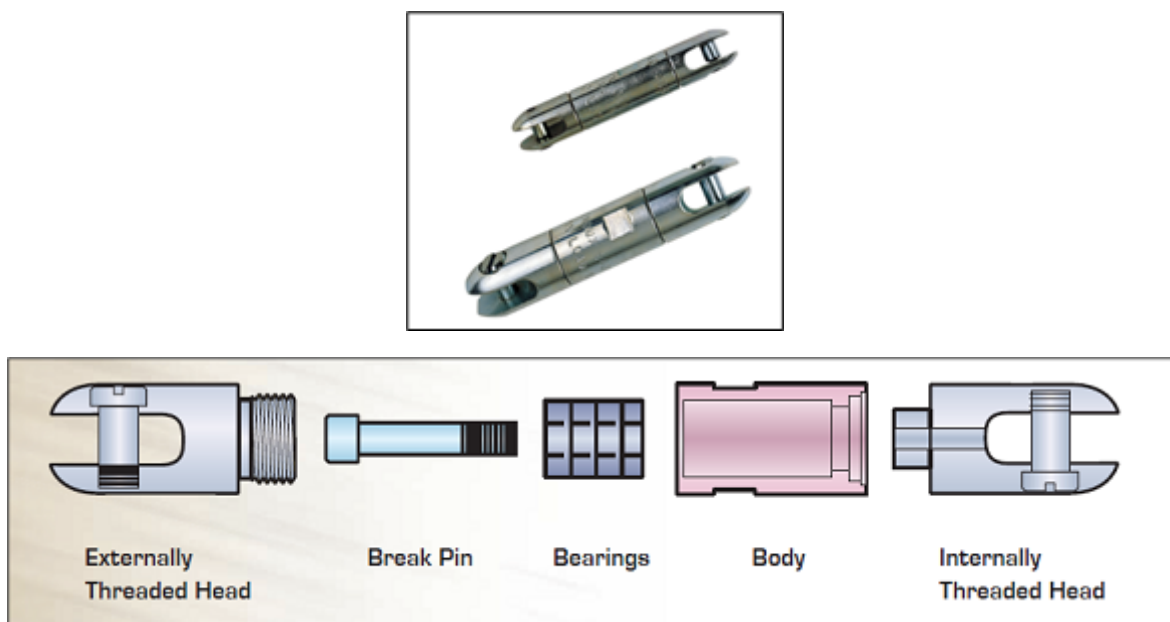

Figure 2: Condux Swivel
(Information available online [here](#).)

Table 5: Condux Swivel Part Numbers for PE 2708 (MDPE)

PE 2708							
Size	SDR	Max Tensile Load (lbs)	Swivel Part #	Size	Break Load (lbs)	Replacement Pin Part #	Pin Color
1/2" CTS	7.0	115	n/a	n/a	n/a	n/a	n/a
1" CTS	11.5	242	8021020	7/8"	200	8018306	Green / Orange
2" IPS	11.0	1,128	8021110	7/8"	1,100	8018905	White / Yellow
4" IPS	11.5	3,888	8076100	1-1/4"	3,400	8076105	Blue / Yellow
6" IPS	11.5	8,428	8027900	1-5/8"	8,000	8027905	Yellow
8" IPS	13.5	12,340	8029600	2-1/2"	12,000	8029605	White

Note: Consult engineering for Maximum Allowable Tensile Load for the following bore lengths:

- Greater than 500 feet for 1/2" CTS and 1" CTS PE pipe
- Greater than 1,500 feet for 2" through 8" PE pipe

Table 6: Condux Swivel Part Numbers for PE 4710 (HDPE)

PE 4710							
Size	SDR	Max Tensile Load (lbs)	Swivel Part #	Size	Break Load (lbs)	Replacement Pin Part #	Pin Color

1/2" CTS	n/a	144	n/a	n/a	n/a	n/a	n/a
1" CTS	11.0	301	8021025	7/8"	250	8018005	Blue / White
2" IPS	11.0	1,387	8021130	7/8"	1,300	8019105	Brown / Yellow
4" IPS	11.0	4,981	8019900	1-3/8"	4,500	8019905	Slate / Yellow
6" IPS	11.0	10,797	8029400	2"	10,000	8029405	Green

Note: Consult engineering for Maximum Allowable Tensile Load for the following bore lengths:

- Greater than 500 feet for 1/2" CTS and 1" CTS PE pipe
- Greater than 1,500 feet for 2" through 8" PE pipe

11.0 Tracer Wire

11.1 [Table 7](#) indicates approved and stock coded tracer wires to be used for PE installation:

Table 7: Tracer Wires

Stock Code	Description	Spool Length	Tensile Strength
18 66 208	#12 Solid Soft Drawn Copper	500 ft.	198 lbs.
18 66 369	#12 Solid Soft Drawn Copper	1,500 ft.	198 lbs.
18 52 049	#10 Stainless Steel Stranded	530 ft.	1,260 lbs.
18 52 050	#10 Stainless Steel Stranded	1,000 ft.	1,260 lbs.

Note: #14 solid soft drawn copper tracer wire (18 66 677) is approved for service line insertion only if there is insufficient space for #12 tracer wire.

11.2 The tracer wire should not be wrapped around or taped to the pipe.

11.3 Contact with the pipe should be minimized but is not prohibited.

11.4 If wire breakage is a concern when boring or plowing, two tracer wires may be pulled. The wire ends should be connected.

11.5 Consider using stainless steel tracer wire for long and/or difficult directional bores or plow-ins.

11.6 When stainless steel wire is installed with main:

11.6.1 Bring up a test station at the location where the stainless wire meets the copper wire.

11.6.2 A lead from each wire should be run up and terminated in the test station.

11.6.3 If installation of a test box is not possible or feasible, the stainless and copper tracer wires can be connected in the same manner as copper service line tracer wire is connected to stainless steel main line tracer wire.

11.7 When connecting PE service line copper tracer wire to the PE main stainless steel tracer wire:

11.7.1 The wires can be connected with a stock coded split bolt connector.

11.7.2 Coat the connection with TL101 Corrosion Inhibitor (31 59 733), then encapsulate in gel box.

11.8 The tracer wire shall have continuity throughout the plastic system.

11.9 The tracer wire should be joined with a stock coded split-bolt connector and the connection protected by a splice box. See [Table 8](#).

Table 8: Split-Bolt Connector and Splice Box

Stock Code	Description
17 54 842	Connector, Split Bolt, Copper
17 54 959	Connector, Split Bolt, Stainless Steel
49 62 001	Box, Splice, Plastic, (Raychem GHFC-1-SBC-OF)

11.10 When the wires are joined together or connected to steel risers, mains or service lines, the connection shall be wrapped or coated with an approved coating. See [CORR 2.3](#) Coatings.

11.11 Five pound magnesium anodes should be installed approximately every 1,000 feet and at the ends of the tracer wire. The anode will cathodically protect the tracer wire and aid in locating the main ends.

11.12 Consider installing test lead box or pipeline marker with fink station as tracer wire access points when service line connections are not available.

12.0 Damage During Construction

12.1 Each PE pipe segment containing an imperfection or damage that would impair the serviceability of the pipe shall be removed.

12.2 Any nick, gouge or indentation that is greater than 10% of the wall thickness is considered a defect and shall be cut out.

12.3 To determine wall thickness loss of PE pipe, see [POLY 2.7](#) Evaluating PE Pipe Damage.

12.4 For repair requirements, see the [REPR 1 Section 9.0](#) PE Pipe Repair.

13.0 Buried Pipe Examination

13.1 A Buried Pipe Examination form shall be completed within ClickMobile whenever existing buried gas carrying plastic main or service is exposed and will be left in service. See [CORR 1](#) for inspection instructions.

End of Instructions.

Operator Qualification (OQ) Required?

YES

0641: Visually Inspect Pipe and Components Prior to Installation

0901: Installation of Plastic Pipe in a Ditch

0911: Installation of Plastic Pipe in a Bore

0921: Installation of Plastic Pipe Plowing/Pull-in

0931: Installation of Plastic Pipe in Plowing/Planting

Appendices

NONE.

Attachments

UNCONTROLLED IF PRINTED

NONE.

Compliance Requirements

49 CFR §192.59 Plastic pipe.

49 CFR §192.321 Installation of plastic pipe.

Reference Documents

[CORR 2.3 Corrosion Control: Coatings](#)

[MAIN](#) and [SERV](#) sections

[POLY 2.7 Polyethylene Pipe: Evaluating PE Pipe Damage](#)

[POLY 3.1 Polyethylene Pipe: Protective Sleeves and Transition Fittings](#)

[POLY 4 Polyethylene Pipe: Forms and Reference Materials](#)

[REPR 1 Repair: Requirements](#)

Document Rescission

POLY 2.3 Installation Requirements, April 1, 2021

Revision Notes

Location of Changes	Summary of Changes
Subsection 10.1	Added – trenchless excavations
Paragraph 10.1.4	Added – through the ground or casing. Pulling pipe in by hand through the ground or casing.
Paragraph 10.2.1 - Item 3	Weak link is required when pulling pipe by hand through the ground or casing.
Subsection 10.4 Condux Swivels	Corrected Replacement Pin Part No. for the 1" CTS swivel for PE2708 pipe.

POLYETHYLENE PIPE

October 1, 2021

POLY 2.4 Butt Fusion

1.0 Purpose

This document describes the requirements for joining polyethylene (PE) pipe and fittings by manual and hydraulic butt fusion.

Joining procedures must meet the minimum requirements of 49 CFR §§ 192.281 and 192.283.

2.0 Scope

This document addresses the following:

[3.0 Target Audience](#)[4.0 Definitions](#)[5.0 General](#)[6.0 Safety - Before Starting Fusion Operation](#)[7.0 Adverse Weather Conditions](#)[8.0 Joint Assembly](#)[9.0 Hydraulic Machine Fusion](#)

Appendices

[Appendix A - Butt Fusion Fittings](#)

3.0 Target Audience

- Gas Engineering
- Gas Distribution Design Specialist
- Field Engineering Representatives
- Gas Field Personnel
- Gas Supervisors
- Gas Construction Services Personnel

4.0 Definitions

- 4.1 Cool Time: Time required before the fitting or pipe may be removed from the butt fusion machine.
- 4.2 Fusion Bead: Size of bead required for an acceptable joint when fusion is complete.
- 4.3 Fusion Force: Force to be applied and maintained between the fitting and pipe after removing the heating iron and melt bead is formed, to complete fusion joint.
- 4.4 Heating Force: Force to be applied and maintained between the fitting or pipe and the heating iron.
- 4.5 Manual Hold Time: Time that operator manually holds fusion pressure after which the locking cam will maintain pressure.
- 4.6 Total Fusion Pressure Hold Time: Total time, including Manual Hold Time, that fusion pressure must be applied to the fitting or pipe after heating iron is removed.
- 4.7 Melt Bead: Bead size required before the heating iron can be removed from the fusion area.

UNCONTROLLED IF PRINTED

- 4.8 Work Time: Additional cool down time before subjecting the fused joint to pulling, installing, pressure testing, rough handling or backfilling.

5.0 General

- 5.1 Butt fusion is **not** allowed when connecting two pipe sections with a wall thickness difference that exceeds one SDR value (e.g., SDR 7.0 vs SDR 11.0) OR if one section of pipe is Aldyl A.
- 5.2 MDPE and HDPE pipe and fittings can be butt fused together.

6.0 Safety - Before Starting Fusion Operation

Direct application of open flame devices, such as torches, for heating polyethylene pipe is strictly prohibited.

- 6.1 To ensure a uniform and consistent butt fusion joint, the pipe preparation and process used are critical.
- 6.2 Inspect the pipe lengths and fittings for unacceptable cuts, gouges, deep scratches or other external defects. See [POLY 2.7](#) - Evaluating PE Pipe Damage.
- 6.3 Tools used to make butt fusion joints shall be specifically designed and correctly sized for the joint being made. The required tools are:
- 6.3.1 Pipe cutter
 - 6.3.2 Pyrometer or electronic temperature indicating instrument
 - 6.3.3 Butt fusion machine
 - 6.3.4 Clean non-synthetic cloth, wooden tool or paper towels
 - 6.3.5 Heating iron with insulated bag
- 6.4 Check heating faces to ensure they are clean and free of damage.
- 6.4.1 Clean non-synthetic cloth or paper towels can be used to clean faces.
- 6.5 Check heating iron for proper temperature (range 400-450°F):
- 6.5.1 Verify temperature with a pyrometer or infrared thermometer each day before the first fusion.

Infrared pyrometers should have an emissivity setting of 0.95.

- 6.5.2 Temperature shall be checked in the fusion zone on both heating faces at approximately 12 o'clock, 3 o'clock, 6 o'clock, and 9 o'clock positions.
 - 6.5.3 Temperature readings should not vary by more than 20 degrees. All shall be in 400-450°F range.
- 6.6 Inspect the butt fusion machine.
- 6.6.1 The jaws, insert serrations, and clamp knob eyebolts should be clean and free of dirt.
 - 6.6.2 The facing blades shall be sharp and free from nicks.

UNCONTROLLED IF PRINTED

- 6.6.3 The machine should move freely on the guide rods.
- 6.6.4 Lubricate the machine as needed.
- 6.6.5 Install the correct shell liners for the size pipe being joined.

7.0 Adverse Weather Conditions

- 7.1 Protect joining operations from wind, rain, or snow. High wind, rain, snow, and cold temperatures can affect the quality of fusion joints.
- 7.2 At temperatures below 32°F, it may be necessary to use longer heating cycle to get a proper melt bead.
 - 7.2.1 **Do not** increase the heating tool surface temperature.
 - 7.2.2 **Do not** increase butt fusion joining pressure.

8.0 Joint Assembly

- 8.1 Inspect the pipe ends.
 - 8.1.1 Ensure pipe ends are clean prior to placing in the butt fusion machine. If needed, clean with water, alcohol solution or clean rag/towel.
 - 8.1.2 Factory ends of stick pipe may be necked-down.
 - 1. Two necked-down factory ends may be butt fused together.
 - 2. **Do not** butt fuse a necked-down factory end to a pipe that has been field cut. Remove the necked-down portion of pipe.
 - 8.1.3 Remove any flattened or damaged ends.
- 8.2 Place pipe (fitting) ends into fusion machine clamps.

Overtightening of the clamps can flare the pipe ends, resulting in poor alignment.

- 8.2.1 Ends should extend approximately 1" past alignment clamps for facing.
- 8.2.2 With four-clamp machines, the outer clamps should be securely tightened to prevent pipe slippage. Inner clamps can be looser to allow easier high/low alignment adjustment.
- 8.2.3 In the case of coiled pipe, it may be necessary to "S" the pipe into the fusion machine to accomplish alignment.
- 8.2.4 Check for alignment and slippage.
- 8.3 Insert facing unit.
 - 8.3.1 Close pipe (fitting) ends against rotating facing blades and machine pipe (fitting) ends to smooth, flat surfaces.
 - 8.3.2 Long continuous shavings will indicate proper facing of pipe ends.
 - 8.3.3 Continue facing until facer contacts stop and check for high-low alignment.
 - 8.3.4 When using an electric (powered) facer, hold pressure closed until the facer stops completely.

Electric (powered) facers shall be turned off before removal.

8.4 Remove facer unit.

8.4.1 Move jaws apart.

8.4.2 Remove facer.

8.4.3 Remove any cuttings with a clean paper towel.

8.4.4 **Do not** touch the faced ends of the pipe.

8.4.5 If facing is incomplete, repeat steps [8.2](#) (place pipe (fitting) ends into fusion machine clamps) and [8.3](#) (insert facing unit).

Alcohol, denatured alcohol and other solvents shall **not** be used to clean the pipe after facing.

8.5 Check alignment.

8.5.1 Bring pipe ends together.

8.5.2 If high-low alignment exists, adjust by tightening the high side clamp and reface the pipe. Do not loosen the low side clamp.

8.5.3 If slippage occurs, return to step [8.2](#) (place pipe (fitting) ends into fusion machine clamps).

8.5.4 Make a final check for proper alignment and detectable gaps.

8.6 Clean heating faces with non-synthetic cloth or paper towels.

8.7 Insert heating iron between pipe ends.

8.7.1 Close pipe ends against heater faces strongly enough to ensure full contact.

8.7.2 Reduce the pressure to contact pressure only.

If excessive pressure of the pipe against the iron is maintained during the melting time, melt will be squeezed away from the pipe end. This will result in a weakened joint after fusion.

8.8 Hold pipe ends in contact with heater.

8.8.1 During the heating cycle, the melt bead will form and expand as the plastic melts.

8.8.2 Refer to [Table 1](#) for proper melt bead size.

8.8.3 When the proper melt bead is formed, quickly separate the ends.

8.8.4 Remove the heating tool, being careful not to displace melt.

8.9 Inspect the pipe ends for complete melt.

- 8.9.1 If there is a concave appearance, it indicates excessive pressure during the heating cycle. Remove the pipe and start over.
- 8.9.2 Manual machines may require quick-snapping actions to open the pipe ends and remove the heater.
- 8.10 Bring the pipe ends together quickly. Do not slam together as this may cause excessive displacement of the melt, resulting in a poor quality joint.
 - 8.10.1 Use enough pressure to roll the melt beads over to the pipe surface. Hand hold pressure for 10 seconds minimum (Manual Hold Time) after which the locking cam will maintain the pressure.
 - 8.10.2 Ensure locking cam mechanism is set and the pressure is maintained for the Cooling Time listed in [Table 1](#).
 - 8.10.3 The double bead width should be about 2 to 2½ times its height, and uniform in size and shape around the joint. See [Figure 1](#).

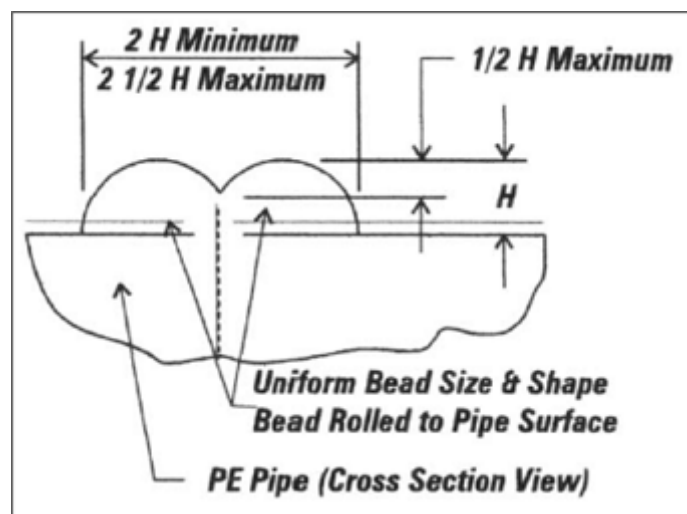

Figure 1

Failure to follow proper heating procedures, contact pressure, and cool time will result in a bad joint.

- 8.11 After the required cooling time, the joint may be carefully removed.
- 8.12 Perform bead inspection after the joint cools and the pressure is taken off the butt fusion machine. The joint needs to be removed from the machine in order to inspect the full circumference of the joint.
 - 8.12.1 Visually inspect all butt fusion joints to ensure the joint is acceptable. If unacceptable, then cut the joint out and start over. [Figure 2](#) shows visually acceptable and unacceptable beads.
 - 8.12.2 Note the following characteristics of *acceptable* beads:
 1. When butt fusing to a molded fitting, the fitting side bead may have an irregular appearance due to the molded part cooling and knit lines, provided the pipe side bead is correct.

2. MDPE bead may be larger than HDPE bead when fusing two dissimilar materials. Both bead sizes must be uniform around their respective pipes.

8.13 After the required cooling time and work time, the pipe may be rough handled or pressure tested.

Table 1: Melt Bead Size and Minimum Cooling and Work Times

Pipe Size	Temperature	Melt Bead Size	Cooling Time		Work Time
			Manual Hold Time	Total Fusion Pressure Hold Time (includes Manual Hold Time)	
½" CTS	400 - 450°F	1/32"	10 seconds	3 minutes	10 minutes
1" CTS	400 - 450°F	1/32"	10 seconds	3 minutes	10 minutes
1 1/4" IPS	400 - 450°F	1/32"	10 seconds	3 minutes	30 minutes
2" IPS	400 - 450°F	1/16"	10 seconds	3 minutes	30 minutes
4" IPS	400 - 450°F	3/16"	10 seconds	5 minutes	30 minutes
6" IPS	400 - 450°F	3/16"	10 seconds	7 minutes	30 minutes
8" IPS	400 - 450°F	3/16"	15 seconds	8 minutes	30 minutes
12" IPS	400 - 450°F	1/4"	15 seconds	13 minutes	30 minutes

8.13.1 Example: For 4" IPS, Total Fusion Pressure Hold Time is 5 minutes and includes Manual Hold Time of 10 seconds, after which the locking cam will maintain the pressure. Wait 30 minutes (Work Time) before subjecting the fused joint to pulling, installing, pressure testing, rough handling or backfilling.

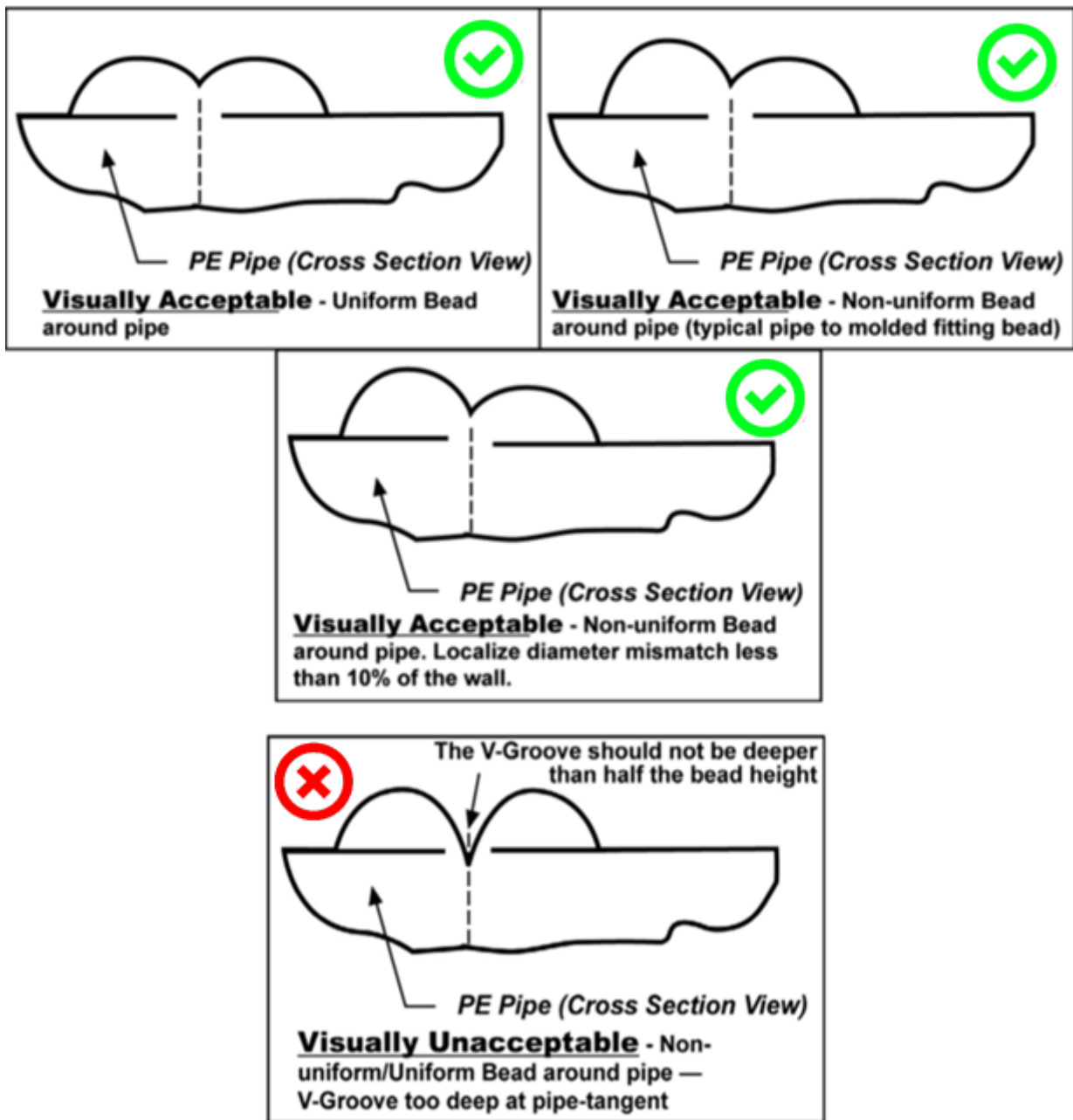

Figure 2: Acceptable and Unacceptable Beads

9.0 Hydraulic Machine Fusion

- 9.1 Follow the operating instructions contained in the hydraulic butt fusion machine manufacturer's instructions.

End of Instructions.

Operator Qualification (OQ) Required?

YES

0751: Joining of Plastic Pipe: Butt Heat Fusion: Manual

0761: Joining of Plastic Pipe: Butt Heat Fusion: Hydraulic Machine

Appendices

[Appendix A - Butt Fusion Fittings](#)

UNCONTROLLED IF PRINTED

Attachments

NONE.

Compliance Requirements

49 CFR §192.281 Plastic pipe.

49 CFR §192.283 Plastic pipe: Qualifying joining procedures.

Reference Documents

[POLY 2.7 Polyethylene Pipe: Evaluating PE Pipe Damage](#)

Performance Pipe PP-750 online reference [here](#).

ASTM F2620-19, Standard Practice for Heat Fusion Joining of Polyethylene Pipe and Fittings

PPI TR-33, Generic Butt Fusion Joining Procedure for Field Joining of Polyethylene on-line reference [here](#).

Document Rescission

POLY 2.4 Polyethylene Pipe: Butt Fusion, April 1, 2021

Revision Notes

Location of Changes	Summary of Changes
Appendix A – A-4 End Caps	Remove the 1/2" & 1" CTS PE 3408 Butt Fusion End Caps. 6" PE 3408 End Cap is being set-up to stock at MDF
Appendix A – A-5 Purge Caps	PE2406 Purge Cap Pup is 1" CTS x 12" Long PE 3408 Purge Cap Pup is 1/2" CTS x 24" Long

Appendix A - Butt Fusion Fittings

A-1. Tees

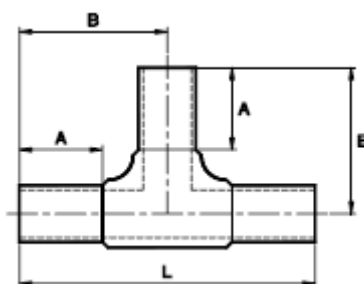

Nominal Pipe Size (inches)	Dimensions A x B x L (inches)	PE2406		PE3408	
		DR	Stock No	DR	Stock No
1 1/4" IPS	2.75 x 4.53 x 9.25	10	19 17 322	N/A	N/A
2" IPS	2.88 x 5.125 x 10.25	11	19 17 193	11	19 22 237
3" IPS	3.00 x 5.72 x 11.44	11/11.5	19 17 106	N/A	N/A

UNCONTROLLED IF PRINTED

4" IPS	3.00 x 6.75 x 13.50	11/11.5	19 17 292	11	19 22 238
6" IPS	4.06 x 8.31 x 16.62	11/11.5	19 17 167	11	19 22 239
8" IPS	6.00 x 12.09 x 24.18	13.5	19 17 107	N/ A	N/A
12" IPS	7.50 x 15.88 x 31.75			11	19 22 511

A-2. Elbows - 90°

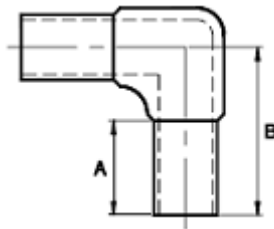

Nominal Pipe Size (inches)	Dimensions A x B (inches)	PE2406		PE3408	
		DR	Stock No	DR	Stock No
1 ¼" IPS	3.13 x 4.50	10	19 17 323	N/A	N/A
2" IPS	2.88 x 5.06	11	19 17 070	11	19 22 229
3" IPS	3.00 x 5.63	11/11.5	19 17 072	N/A	N/A
4" IPS	3.00 x 6.75	11/11.5	19 17 073	11	19 22 230
6" IPS	4.00 x 8.25	11/11.5	19 17 074	11	19 22 231
8" IPS	6.00 x 11.81	13.5	19 17 297	11	19 22 518
12" IPS	7.50 x 15.88		N/A	11	19 22 510

A-3. Elbows - 45°

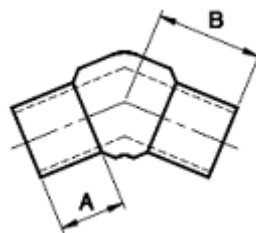

Nominal Pipe Size (inches)	Dimensions A x B (inches)	PE2406		PE3408	
		DR	Stock No	DR	Stock No
3" IPS	3.10 x 5.38	11/11.5	19 17 254	N/A	N/A
4" IPS	3.00 x 4.93	11/11.5	19 17 244	11	19 22 504
6" IPS	4.00 x 6.38	11/11.5	19 17 087	N/A	N/A
8" IPS	6.00 x 10.00	13.5	19 17 088	N/A	N/A
12" IPS	7.50 x 15.75			11	19 22 515

UNCONTROLLED IF PRINTED

A-4. End Caps

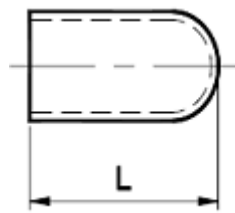

Nominal Pipe Size (inches)	Dimension L (inches)	PE2406		PE3408	
		DR/Wall	Stock No	DR/Wall	Stock No
1 ¼" IPS	3.94	10	19 17 315	N/A	N/A
2" IPS	4.25	11	19 17 340	11	19 22 232
3" IPS	3.94	11/11.5	19 17 202	N/A	N/A
4" IPS	4.25	11/11.5	19 17 095	11	19 22 233
6" IPS	5.20	11/11.5	19 17 096	11	19 22 234
8" IPS	5.00	13.5	19 17 097	N/A	N/A
12" IPS	13.88		N/A	11	19 22 507

A-5. Purge Caps

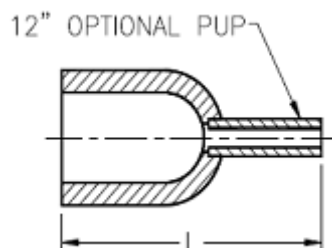

PE 2406 Pup is 1" CTS and 12" long (0.101" wall).

PE 3408 Pup is 1/2" CTS and 24" long (0.090" wall)

Nominal Pipe Size (inches)	Dimension L (inches)	PE2406		PE3408	
		DR	Stock No	DR	Stock No
2" IPS	16.25	11	19 22 319	11	19 72 164
3" IPS	15.94	11/11.5	19 22 320	N/A	N/A
4" IPS	16.25	11/11.5	19 22 321	11	19 72 165
6" IPS	17.20	11/11.5	19 22 324	11	19 72 166
8" IPS	17.00	13.5	19 22 322	N/A	N/A

A-6. Reducers

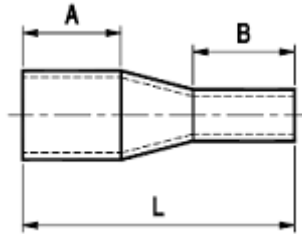

Nominal Pipe Size (inches)	Dimension L x A x B (inches)	PE2406		PE3408	
		DR/Wall	Stock No	DR/Wall	Stock No
1 ¼" IPS x 1" CTS	4.78 x 1.70 x 1.76	10 x 0.102	19 22 417	N/A	N/A
2" IPS x 1 ¼" IPS	6.88 x 2.88 x 3.25	11 x 10	19 17 324	N/A	N/A
3" IPS x 2" IPS	8.00 x 3.12 x 2.81	11/11.5 x 11	19 17 062	N/A	N/A
4" IPS x 2" IPS	7.75 x 3.06 x 2.81	11/11.5 x 11	19 17 064	11 x 11	19 22 235
4" IPS x 3" IPS	7.88 x 3.12 x 3.00	11/11.5 x 11/11.5	19 17 066	11 x 11	19 72 155
6" IPS x 4" IPS	11.50 x 4.12 x 4.12	11.5 x 11.5	19 17 067	11 x 11	19 22 236
8" IPS x 6" IPS	11.62 x 4.37 x 4.50	13.5 x 11/11.5	19 17 068		
8" IPS x 6" IPS	11.81 x 5.06 x 4.88			11 x 11	19 22 513
12" IPS x 8" IPS	15.00 x 6.63 x 6.65			11 x 11	19 22 512

1.0 Purpose

This document describes the requirements for joining polyethylene (PE) pipe and fittings by electrofusion.

Joining procedures must meet the minimum requirements of 49 CFR §§ 192.281 and 192.283.

2.0 Scope

This document addresses the following:

[3.0 Target Audience](#)

[4.0 Common Requirements](#)

[5.0 Safety - Before Starting Fusion Operation](#)

[6.0 Electrical Equipment Requirements](#)

[7.0 Out of Roundness](#)

[8.0 Pipe Surface Preparation](#)

[9.0 Peeling](#)

[10.0 Joint Assembly](#)

[11.0 Electrofusion Tapping Tee Repair Kit Instructions](#)

[12.0 Fusion](#)

[13.0 Pressure Testing](#)

[14.0 Re-Fusing](#)

[15.0 Tapping](#)

Appendices

[Appendix A - Electrofusion Fittings](#)

[Appendix B - Manufacturer Cooling Times](#)

3.0 Target Audience

- Gas Engineering
- Gas Supervisors
- Gas Field Personnel
- Gas Construction Services Personnel

4.0 Common Requirements

The following requirements are applicable to all electrofusion processes.

4.1 Application

- 4.1.1 Electrofusion couplings shall **not** be installed onto butt fusion fittings, caps, elbows or in-line tees.

4.1.2 Electrofusion couplings can be installed on PE ball valves, provided the stub length on the valve is long enough for peeling with a rotating peeler.

4.1.3 Electrofusion is required when joining:

1. PE pipe with different wall thickness that exceeds one SDR value (e.g., SDR 7.0 vs SDR 11),

OR

2. PE pipe with different chemical properties (e.g. Aldyl-A to MDPE).

4.2 Handling and Storage

4.2.1 Electrofusion fittings are packaged in sealed plastic bags or boxes for protection from dust, dirt and contamination.

1. Remove fitting from the bag/box when ready to install.

2. If the fitting is exposed to dust, dirt or any other possible contaminate, then clean with alcohol solution or discard.

3. All alcohol used on PE pipe shall be at least 96% isopropyl alcohol.

When working in colder temperatures, be cautious of isopropyl alcohol frosting on pipe or not drying as expected.

4.2.2 All markings on PE pipe shall be made with a non-petroleum-based permanent marker in a color that is clearly visible on the pipe.

4.3 Fusion and Re-Fusion

4.3.1 Electrofusion fittings can be re-fused **only** in the event of an input power interruption. See [Section 14.0](#) Re-Fusing.

4.3.2 Electrofusion fittings that fault for any other termination causes shall be removed or abandoned and replaced with new fittings.

4.3.3 After the fusion cycle is complete, all electrofusion joints shall be visually inspected and accepted before being placed in service. If joint is unacceptable, then cut the joint out and start over.

4.4 Electrofusion Repair Kit for Aldyl-A Tapping Tee Caps

4.4.1 Installation procedures are in [Section 11.0](#) Electrofusion Tapping Tee Repair Kit Instructions

5.0 Safety - Before Starting Fusion Operation

Electrical equipment used for electrofusion is a potential source of ignition.

5.1 **Do not** use electrical equipment in a hazardous environment. Locate generator, control box and supply line junction out of the trench.

5.2 **Do not** connect any other equipment to generator during the fusion process.

- 5.3 **Turn off** auto idle on generator, if equipped, so that it will not kick down during fusion process.
- 5.4 In inclement weather, protect equipment and fusion surfaces by a temporary shelter. Follow wet weather precautions around electrical equipment.

6.0 Electrical Equipment Requirements

- 6.1 A 120-volt 30-amp power source is recommended to operate the electrofusion control box.
 - 6.1.1 The 30-amp twist lock connection is required when fusing fittings 3" and larger.



Figure 1: Twist Lock Connection

- 6.1.2 If 30-amp plug is not available, then use a pigtail adapter to convert a 30-amp twist lock plug to a 15-amp straight blade plug.



Figure 2: Pigtail Adapter

- 1. If needed, use pigtail adapter only when fusing the following fittings:
 - 1 a. *Tapping tees*: All sizes
 - 1 b. *Fittings 2" and smaller*: Couplings, elbows, reducers, end caps
- 6.2 Receptacles must be fitted with Ground Fault Circuit Interrupter Breakers (GFCI).
- 6.3 A 3500-watt (or larger) generator/inverter OR an appropriate 120-volt wall outlet must be used to power the electrofusion processors.
- 6.4 If an extension cord is used, then refer to Table 1 to select the maximum length and size based on the processor's specifications.

Table 1: Extension Cord Requirements

Processor	Extension Cord Maximum Length & Size		
	25 ft. - #10/3	50 ft. - #8/3	100 ft. - #8/3
Central Plastics Easy Fuse and MSA 340	25 ft. - #10/3	50 ft. - #8/3	
IPEX Genesis F3	25 ft. - #12/3	50 ft. - #10/3	100 ft. - #8/3
Friamat	100 ft. - #10/3	200 ft. - #8/3	
Kerotest Diane and Charlotte	100 ft. - #10/3	200 ft. - #8/3	

6.5 Refer to Table 2 for the manufacturer's operating temperature ranges for some processors used at AIC.

Table 2: Electrofusion Processor Operating Temperature Range

Processor	Operating Temperature Range
Central Easy Fuse	10 to 120°F
Central MSA 340	-10 to 120°F
IPEX Genesis F3	0 to 140°F
Phoenix Battery Box	0 to 120°F
Friamat	-4 to 122°F
Kerotest Diane	-20 to 120°F
Kerotest Charlotte	14 to 120°F

6.6 Electrofusion processors shall be maintained at intervals that meet the manufacturer's minimum requirements. See [POLY 2.11](#), Maintenance of Fusion Equipment. Maintenance records will be maintained in Maximo.

7.0 Out of Roundness

7.1 Since PE pipe is flexible, storage, coiling, stacking, and soil loading can affect the roundness of the pipe. "Out of roundness" is the difference between the outside height and outside width of the pipe, measured with a tape measure or caliper.

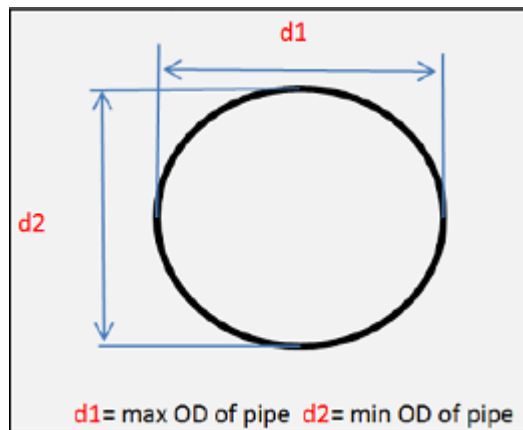

Figure 3: Diameter measurement diagram

7.2 Table 3 shows maximum out of roundness for PE pipe:

Table 3: Maximum Out of Roundness

Pipe Size (IPS)	d1-d2
3"	1/8"
4"	1/8"
6"	3/16"
8"	3/16"
10"	1/4"
12"	1/4"

7.3 Re-rounding of PE pipe

- 7.3.1 2" IPS and smaller: Is flexible enough that couplings and alignment clamps will provide necessary rounding forces to re-round the pipe.
- 7.3.2 Larger than 2" IPS: May require re-rounding clamps to be installed on either side of the electrofusion fitting.

8.0 Pipe Surface Preparation

8.1 Couplings, Caps, Elbows, and Saddle Fittings

- 8.1.1 For the initial pipe cleaning, remove mud, dirt, and other foreign material with a clean paper towel or cloth with water or alcohol solution. Do not use detergents to clean pipe.
- 8.1.2 Inspect pipe and remove damaged pipe and neck down pipe ends.
- 8.1.3 Cut pipe ends squarely for couplings, caps, and elbows.
 - 1. The gap between two pipe ends should not exceed 2 times the maximum gap shown in the table. See Table 4.

Table 4 Maximum Allowable Gap from Square

Pipe Size	Central Plastics	Innogaz/Friatec
1/2" - 1" CTS	1/8"	1/16"
1-1/4"	1/8"	1/16"
2" IPS	3/16"	1/8"
3"	5/16"	3/16"
4"	5/16"	1/4"
6" IPS	1/2"	3/8"
8" IPS	3/4"	1/2"
10" IPS	7/8"	
12" IPS	1"	

- 8.1.4 Refer to Table 5 for the limits of the area to be cleaned and peeled.
 - 1. Pipe shall be initially cleaned of dirt, boring mud or other foreign material prior to marking the area to be cleaned with alcohol. Water and paper towels/ clothes can be used for this initial cleaning.
 - 2. Mark the limits of the area to be cleaned. If there is insufficient space to get 3 times the fitting length, then clean the available exposed area.
 - 3. Clean within marked area with alcohol wipes or a paper towel with alcohol solution. Wipe in one direction and do not clean beyond the marks. Allow the alcohol to dry and keep this area free from any contamination. Discard the wipe or towel; do **not** reuse.
 - 3 a. Marks shall be visible.
 - 3 b. Remaining fusion activity shall be kept within this marked area to avoid dragging contaminated material into the fusion area.
 - 4. Mark the limits of the area to be peeled.
 - 5. Scribe Witness Marks in the area to be peeled using a crisscross pattern at regular intervals around the pipe and fitting.

Table 5: Pipe Surface Area Preparation

Fitting	Area to be cleaned	Area to be peeled
Couplings and caps	3 times the fitting length	Half the fitting length. If the full coupling is to be slid onto the pipe, then mark the full length on the first pipe.
Elbows	3 times the insertion depth (Note that insertion depth of Central Plastic's 2" elbow is 2¼")	Insertion depth
Tees	Full length of tee outlet	Insertion depth
EFVs	Full length of EFV outlet	Insertion depth
Saddles	3 times the width of the saddle	Slightly wider than the base of the saddle

9.0 Peeling

- 9.1 The only tools to be used for electrofusion surface preparation are those specifically designed to peel the pipe surface to a controlled depth.

Hand scraping is allowed only when the use of a rotating peeler is not feasible and must be approved by the Gas Supervisor.

- 9.2 Use an approved peeler for pipe ends, EFV ends, tee outlets and saddle connections.
- 9.2.1 1-1/4" and 2" IPS pipe may require the use of insert stiffener to straighten and round the pipe.
- 9.2.2 The 1" and 2" PE 4710 service riser pigtails are SDR 7.0 and require a different insert stiffener than the 1" CTS (SDR 11.1) and 2" IPS (SDR 11.0) PE 4710 pipe.
- 9.3 Electrofusion cap insert
- 9.3.1 If the insertion cap remains inside the coupling, do **not** peel the insertion cap.
- 9.3.2 If the insertion cap does **not** remain inside the coupling, then clean the insertion cap and insert into the coupling.
- 9.4 Inspect Peeler
- 9.4.1 Ensure tool is operating properly. Replace worn or defective parts.
- 9.4.2 Ensure tool is clean of contaminating material such as grease, mud or other debris.
- 9.4.3 Check condition of blades. Replace if dull or damaged.
- 9.5 Peeling
- 9.5.1 Note the number of passes allowed with the peeler.
1. Pipe 2" IPS and smaller: One pass
 2. Pipe 3" and larger: Two passes

- 9.5.2 Completely peel the marked area to expose clean, virgin material. Ribbon material should be uniform.
- 9.5.3 Break shavings or guide them away to prevent them from wrapping around the peeled area of the pipe surface.
- 9.5.4 Ensure all Witness Marks have been removed. If marks remain, then remove that section of pipe and start over.
 - 1. Peeling at end of pipe: Remove that section of pipe and start over.
 - 2. Peeling within pipe segment: Move to a new location and start over. Tape over the previously peeled section to indicate tapping of the section shall be avoided in the future.
- 9.5.5 Central Plastics electrofusion coupling, ½"-1" only: Kerotest rotating peelers will not peel the entire marked area due to the blade configuration. The peeler is still acceptable since the full electrofusion area of the coupling is peeled.
- 9.5.6 If there is a possibility the peeled area has been contaminated, then clean with alcohol wipes or solution. Use the wipes and towel only once, then discard. Avoid touching cleaned surfaces.
- 9.5.7 Allow peeled surface to dry before fusing.

10.0 Joint Assembly

10.1 Couplings, Caps, and Elbows

- 10.1.1 Re-mark the stab depth if the initial marking is not visible.
- 10.1.2 Slide the fitting onto the first pipe to the insertion depth. Insert the second pipe into the fitting.
 - 1. Couplings: If necessary, slide the full length of coupling on to the first pipe. Butt the second pipe up to the first pipe and slide the coupling onto the second pipe to the insertion mark.
- 10.1.3 Insertion depth mark should be visible on both ends of the fitting.
- 10.1.4 Select the proper clamp and secure the fitting in proper alignment.
 - 1. Caps: Mark the spigot on the outside of the fitting to ensure spigot does not move.

10.2 Saddle Fittings (Service tees, high volume tees, repair saddles)

- 10.2.1 Place the fitting onto the pipe within the peeled area. There should be visible peeled area at both ends of the saddle.
- 10.2.2 Select the proper clamp.
 - 1. Fittings with integrated bolt on clamps: Tighten clamp so that the tee or saddle is held securely in place with equal pressure.
 - 2. Fittings with external, reusable clamps (under-clamp, strap or top loading clamp):
 - 2 a. Center the clamp on the fitting.
 - 2 b. Apply the proper pressure to securely hold the fitting on the pipe.
 - 2 c. Lock the clamp in place.

- 10.2.3 To eliminate stress during the fusion process, it may be necessary to support connections to service tees or high volume tees

11.0 Electrofusion Tapping Tee Repair Kit Instructions

- 11.1 After exposing tapping tee, remove residual dirt or soil from the stack to prevent damaging the peeler. If necessary, use clean water or a minimum 96% alcohol solution for initial cleaning of tee. Wipe dry with a clean paper towel before peeling.
- 11.2 Peel outside diameter of the Aldyl-A tapping tee stack down to the intersection of tee outlet.
- 11.2.1 The Kerotest peeler is a double-bladed peeler with “A” and “B” ends. Begin the peeling operation with end “A”.
- 11.2.2 Once the peeler bottoms out on end “A”, flip the peeler over to complete peeling with “B” end.
- 11.3 After peeling the tee stack, clean the stack using a minimum 96% alcohol solution wipe, or clean paper towel with a minimum 96% alcohol solution and allow to dry.
- 11.4 Remove the repair kit from the bag.
- 11.5 Because gas may be leaking, remove plug from the repair fitting until completing the electrofusion of coupling and insert repair fitting to the tapping tee.
- 11.6 Before performing electrofusion, clean the diameter of the insert repair fitting. Use a wipe/clean paper towel that contains a minimum 96% alcohol solution. Allow to dry.

It is not necessary to peel the outside diameter of the base fitting.

- 11.6.1 If the insert repair fitting becomes contaminated during the assembly process, clean the insert fitting with the minimum 96% alcohol solution and reinsert into the repair fitting.
- 11.7 Install insert repair fitting into the electrofusion coupling until the fitting shoulder stops against the end of the electrofusion coupling.
- 11.8 Install the electrofusion coupling over the Aldyl-A tee stack until it “bottoms out” on the tee outlet.
- 11.9 Screw insert holding tool into the threaded end of insert repair fitting.
- 11.10 Connect fusion processor leads to the electrofusion coupling and fuse coupling and insert assembly to the Aldyl-A tapping tee with standard fusion procedures.
- 11.11 When electrofusion is complete, remove processor cables and allow the electrofusion coupling and insert fitting assembly to cool for a minimum of 10 minutes before completing further assembly work.
- 11.12 Verify that the O-ring seal on the plug repair fitting is lubricated. If not, lightly lubricate with Dow Corning Silicone Grease #111, or equivalent.
- 11.13 After allowing proper cooling time, remove insert holding tool from the insert repair fitting.

- 11.14 Using a standard ½-inch square drive, screw the plug repair fitting with O-ring seal into the insert repair fitting until it bottoms out. Top of plug should be flush with the top of repair fitting.
- 11.15 Soap test the completed repair kit assembly for leakage.
- 11.16 See Figure 1 for illustration of the repair kit assembly.

Figure 1: Repair Kit Assembly

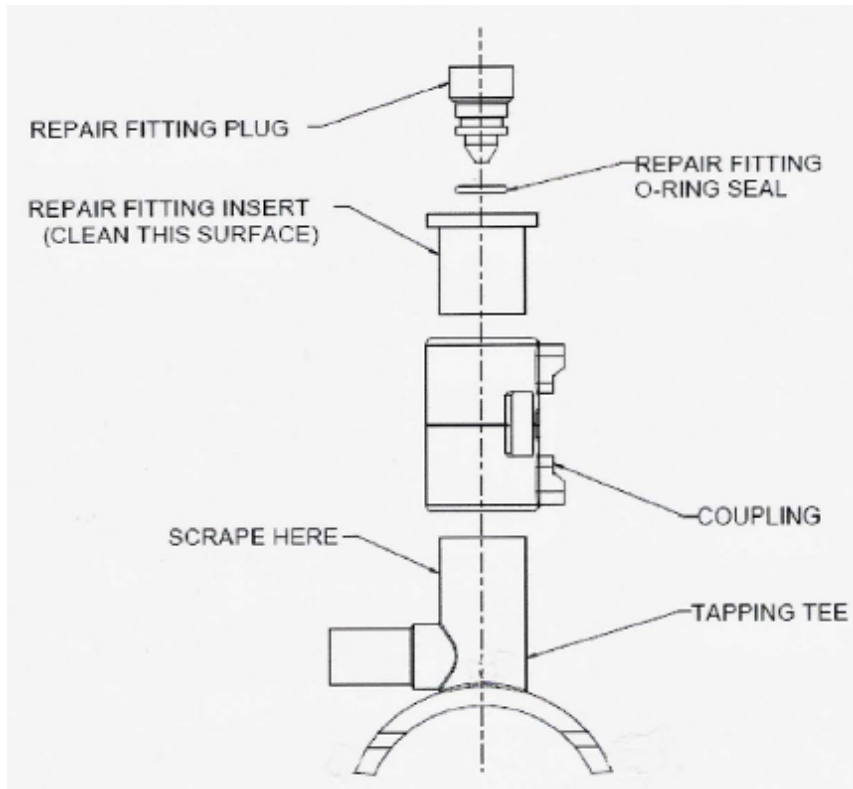

12.0 Fusion

- 12.1 Connect fusion control box leads to the coupling. Once the coupling has been connected, do **not** handle output leads or connectors until fusion is complete.
- 12.2 Ensure fusion time is correctly set for fitting (bar code scan, manual input, or auto-read).
- 12.3 Activate fusion cycle.
- 12.4 Once the controller indicates fusion is complete, the outlet leads may be disconnected.
- 12.5 Allow proper cooling time before removing fitting from the clamp. Refer to fitting tag, processor, or [Appendix B - Manufacturer Cooling Times](#) for individual fitting fusion, cooling and work times.
- 12.6 At the end of the fusion operation, disconnect the electrofusion processor's power cable from the generator.
- 12.7 Shut off the generator.

13.0 Pressure Testing

- 13.1 The fused fitting cannot be pressure tested until after the required cooling time and the clamp is removed. See [Appendix B - Manufacturer Cooling Times](#).

14.0 Re-Fusing

14.1 Re-fusing a fitting is permitted **only** under circumstances of an input power interruption. Events which could cause an interruption include:

14.1.1 Generator power loss to control box.

14.1.2 Accidental disconnection of fusion cables from the fitting during the fusion cycle

14.2 Prepare to re-fuse:

14.2.1 Allow the fitting and pipe to cool completely to ambient temperature.

14.2.2 Use a pyrometer to verify that the fitting and surrounding pipe temperature have equalized.

14.2.3 Read pipe temperature at least 2 feet from the fitting.

14.3 Re-start the fusion. Fuse for the entire fusion cycle prescribed for the fitting. **Do not** subtract time based on the first fusion attempt.

15.0 Tapping

15.1 Electrofusion service and high volume tees shall be pressure tested *before* being tapped.

If the service tee(s) is being tested with the main, then it shall be tapped *before* being pressure tested.

15.2 Electrofusion service and high volume tees can be tapped only after the required cooling time is complete.

See [Appendix B - Manufacturer Cooling Times](#).

15.3 Remove cap from the tee.

For Innogaz tees with no fixed backstop, use of the safety cap is optional. If the safety cap is used for an Innogaz tee, then the safety cap must be removed before installing the tee cap.

15.3.1 Insert tapping tool into top of tee to the cutter.

15.3.2 Turn perforator clockwise until it bottoms out.

15.3.3 Tap the PE pipe. Press and secure the pipe coupon into the inside of the cutter.

15.3.4 Unscrew perforator (counterclockwise) until it comes in contact with backstop or flush with top of tapping tee.

15.3.5 Install the cap according to the manufacturer's specifications.

15.3.6 Check the assembly for leakage.

Service tees that are pressure tested with the main are exempt from this requirement since a successful leak test will document no leakage.

End of Instructions.

Operator Qualification (OQ) Required?

YES

- 0641: Visually Inspect Pipe and Components Prior to Installation
- 0781: Joining of Plastic Pipe - Electrofusion

Appendices

[Appendix A - Electrofusion Fittings](#)

[Appendix B - Manufacturer Cooling Times](#)

Attachments

NONE.

Compliance Requirements

- 49 CFR §192.281 Plastic pipe.
- 49 CFR §192.283 Plastic pipe: Qualifying joining procedures.

Reference Documents

[POLY 2.11 Polyethylene Pipe: Maintenance of Fusion Equipment](#)

GF Central Plastics MSA 340 - See [POLY 4](#).

Document Rescission

POLY 2.5 Polyethylene Pipe: Electrofusion, October 1, 2022

Revision Notes

Location of Changes	Summary of Changes
Paragraph 9.5.4 – Witness marks not removed	Added: 1. Peeling at end of pipe: Remove that section of pipe and start over. 2. Peeling within pipe segment: Move to a new location and start over. Tape over the previously peeled section to indicate tapping that section shall be avoided.
Appendix A – Electrofusion Fittings	Added –Electrofusion fittings listed below are PE4710.

Appendix A - Electrofusion Fittings

Note: Since Ameren Illinois has gone to single source provider, majority of the fittings listed below are Central Plastic's fittings. However, the formerly stock coded Friatec and Innogaz electrofusion fittings remain approved and can be used until the supply has been depleted. If there is a supply issue with Central Plastic, AIC will order needed fittings from Friatec, Innogaz, or other approved manufacturer.

Electrofusion fittings listed below are PE4710.

A-1 Tapping Tee Kits

1/2" CTS Tapping Tee Kits	
Nominal Pipe Size (inches)	Stock Code
1 1/4" IPS x 1/2" CTS	19 22 400
2" IPS x 1/2" CTS	19 22 401
3" IPS x 1/2" CTS	19 22 402
4" IPS x 1/2" CTS	19 22 403
6" IPS x 1/2" CTS	19 22 404
8" IPS x 1/2" CTS	19 22 398
12" IPS x 1/2" CTS	19 22 516

1" CTS Tapping Tee Kits	
Nominal Pipe Size (inches)	Stock Code
1 1/4" IPS x 1" CTS	19 22 405
2" IPS x 1" CTS	19 22 406
3" IPS x 1" CTS	19 22 408
4" IPS x 1" CTS	19 22 410
6" IPS x 1" CTS	19 22 411
8" IPS x 1" CTS	19 22 399
12" IPS x 1" CTS	19 22 517

A-2. High Volume Tapping Tees

Nominal Pipe Size (inches)	Stock Code
2" IPS x 1-1/4" IPS	19 22 407
3" IPS x 1-1/4" IPS	19 22 409
4" IPS x 1-1/4" IPS	19 22 394
6" IPS x 1-1/4" IPS	19 22 396
2" IPS x 2" IPS	19 22 412
3" IPS x 2" IPS	19 22 413
4" IPS x 2" IPS	19 22 414
6" IPS x 2" IPS	19 22 415
8" IPS x 2" IPS	19 17 342
12" IPS x 2" IPS	19 22 498

A-3. Couplings

Nominal Pipe Size (inches)	Stock Code
½" CTS	19 22 505
1" CTS	19 22 506
1 ¼" IPS	19 22 368
2" IPS	19 22 278
3" IPS	19 22 369
4" IPS	19 22 370
6" IPS	19 22 371
8" IPS	19 22 279
12" IPS	19 22 497

A-4. Reducer Couplings

Nominal Pipe Size (inches)	Stock Code
¾" IPS x ½" CTS	19 72 136
1" CTS x ½" CTS	19 22 508
1" CTS x ¾" IPS	19 72 137
1 ¼" IPS x 1" CTS	19 72 127
2" IPS x 1" CTS	19 72 126
2" IPS x 1 ¼" IPS	19 22 248

A-5. End Caps

Nominal Pipe Size (inches)	Stock Code
½" CTS	19 72 141
¾" IPS	19 72 147
1" CTS	19 72 142
1" IPS	19 72 156
1 ¼" IPS	19 72 146
2" IPS	19 72 143
3" IPS	19 22 488
4" IPS	19 22 485
6" IPS	19 22 486
8" IPS	19 22 487
12" IPS	19 22 519

A-6. Elbows - 90°

Nominal Pipe Size (inches)	Stock Code
2"	19 72 158

A-7. TDW PE Side Tap Fittings

Nominal Pipe Size (inches)	Stock Code
8" x 4"	19 67 281
6" x 4"	19 67 282
4" x 4"	19 67 283

A-8. Repair Saddles

Nominal Pipe Size (inches)	Stock Code
4"	19 22 135
6"	19 22 136

A-9. Supraflow Tapping Tees

(Reference available online [here](#).)

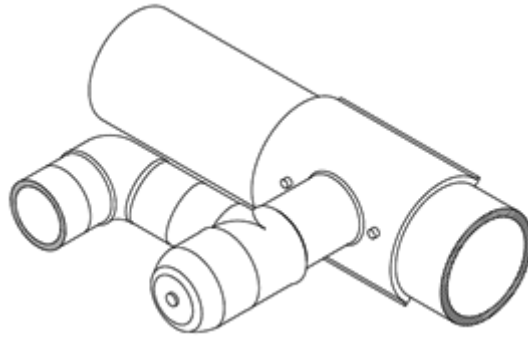

Parallel Outlet

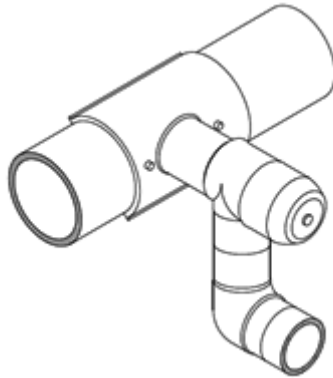

Perpendicular Outlet

Tee x Outlet Pipe Size (inches)	Outlet	Stock Code
4" x 4" IPS	Parallel Outlet	19 22 492
4" x 4" IPS	Perpendicular Bottom Outlet	19 22 489
6" x 4" IPS	Parallel Outlet	19 22 491
6" x 4" IPS	Perpendicular Bottom Outlet	19 22 493
8" x 4" IPS	Parallel Outlet	19 22 490
8" x 4" IPS	Perpendicular Bottom Outlet	19 22 494
8" x 6" IPS	Parallel Outlet	19 22 496
8" x 6" IPS	Perpendicular Bottom Outlet	19 22 495

Note: Supraflow tee outlets include 90° elbow with a 2 ft. pup on the outlet.

A-10 Kerotest Repair Kit of Aldyl-A Tapping Tee Caps (Refer to [REPR 2.3](#) for kit components and required tools)

Stock Code	Description
19 72 134	Kit for standard tapping tee, used 1.25 inch IPS electrofusion coupling and insert.
19 72 153	Kit for non-standard tapping tee, used a 40mm electrofusion coupling and insert.

Appendix B - Manufacturer Cooling Time

The following tables contain cooling times published by each manufacturer for their electrofusion fittings. All cooling times begin at the end of the fusion cycle.

B-1. Central Plastics

Fitting	Size	Cooling Time in Clamped Position (minutes)	Total Cooling Time Before Pressure/Tap (minutes)	Total Cooling Time Before Rough Handling (minutes)
Couplings	½" CTS	5	15	30
	½" CTS x ¾" IPS	5	15	30
	½" CTS x 1" CTS	5	15	30
	¾" IPS x 1" CTS	5	15	30
	1" CTS	5	15	30
	1-¼" IPS	10	20	30
	2" IPS	10	20	30
	3" IPS	15	30	35
	4" IPS	15	30	35
	6" IPS	20	40	45
8" IPS	20	40	45	
Caps	½" CTS	5	15	30
	¾" IPS	5	15	30
	1" CTS	5	15	30
	1 ¼" IPS	10	20	30
	2" IPS	10	20	30
	3" IPS	15	30	35
	4" IPS	15	30	35
	6" IPS	20	40	45
8" IPS	20	40	45	
Elbow	2" IPS	5	20	30
Reducers	¾" IPS x ½" CTS	5	15	30
	1" CTS x ½" CTS	5	15	30
	1" CTS x ¾" IPS	5	15	30

	1-1/4" IPS x 1" CTS	10	20	30
	2" IPS x 1" CTS	10	20	30
	2" IPS x 1-1/4" IPS	10	20	30
Tapping Tees	1-1/4" IPS to 8" IPS	10	20	30
High Volume Tapping Tees	2" IPS to 6" IPS	10	25	30
	8" IPS to 12" IPS	20	30	40

Notes:

1. Rough handling is considered putting pipe in the ditch and backfilling.
2. Example for 2" IPS coupling: Wait 10 minutes before removing clamp, wait another 10 minutes before pressure testing or tapping, then wait another 10 minutes before rough handling the pipe. Total cooling time from end of fusion cycle to rough handling pipe is 30 minutes.

B-2. Friatec

Fitting	Size	Total Cooling Time Before Handling (minutes)	Total Cooling Time Before Pressurizing (minutes)
Couplings	1/2" CTS	5	10
	1/2" CTS x 1" CTS	5	10
	1" CTS	5	10
	1-1/4" IPS	10	25
	2" IPS	10	25
	3" IPS	10	40
	4" IPS	10	40
	6" IPS	20	75
Tapping Tees and High Volume Tapping Tees	1-1/4" IPS	15	20
	2" IPS	15	20
	3" IPS	20	30
	4" IPS	20	30
	6" IPS	30	45
	8" IPS	50	60

Notes:

1. Example for 2" IPS coupling: Wait 10 minutes before removing clamp or handling, wait another 15 minutes before pressure testing or tapping. Total cooling time from end of fusion cycle to pressure testing/tapping is 25 minutes.

B-3. Innogaz

Fitting	Size	Cooling Time Before Removing Clamps (minutes)
Couplings	½" CTS	3
	½" CTS x 1" CTS	4
	1" CTS	6
	1-¼" IPS	6
	2" IPS	20
	3" IPS	8
	4" IPS	10
	6" IPS	14
	8" IPS	18
Tapping Tees	1-¼" IPS to 8" IPS	10
High Volume Tapping Tees	2" IPS to 8" IPS	16

1.0 Purpose

This document describes the requirements for joining polyethylene (PE) pipe and fittings by mechanical connection.

Joining procedures must meet the minimum requirements of 49 CFR §§ 192.281 and 192.283.

2.0 Scope

This document addresses the following:

[3.0 Target Audience](#)

[4.0 General](#)

[5.0 Stab Fittings](#)

[6.0 Perfection PERMASERT/PERMASERT 2.0](#)

[7.0 Compression Fittings](#)

Appendices

[Appendix A - Stab Fittings](#)

3.0 Target Audience

- Gas Engineering
- Gas Supervisors
- Gas Field Personnel
- Gas Construction Services Personnel

4.0 General

- 4.1 Mechanical fittings, including both compression and stab type fittings, installed after January 22, 2019 shall be classified Category 1 meeting ASTM D2513 requirements.
- 4.2 When using a mechanical fitting on PE pipe, a rigid metallic internal stiffener shall be used.
- 4.3 If scratches or gouges are visible on the end surface of the PE pipe, then remove the defective area.
- 4.4 When installing a service header adapter, follow manufacturer's installation instructions.

5.0 Stab Fittings

- 5.1 Stab fittings shall only be used on ½" through 1" PE pipe sizes.
 - 5.1.1 Use stab couplings only to:
 1. Repair service lines, ½" through 1" CTS PE
 2. Cap end of service lines, ½" through 1" CTS PE, may include
 - 2 a. Retirements
 - 2 b. Seal ends temporarily during installation



- 2 c. Temporary bypass
- 3. Cap end of purge cap pigtail, during test and upon completion of test
- 5.1.2 Stab elbows and in-line tees are used on 1/2" through 1" CTS pipe.
- 5.1.3 An electrofusion coupling is required to connect 1" CTS PE 4710 pipe to the service riser pigtail on 1/2" through 1" PE service lines.

The 1" CTS PE 4710 stab coupling internal stiffener is sized for 1" CTS, SDR 11.5 pipe. It is **not** compatible with the 1" CTS PE 4710 service riser pigtail, which is SDR 7.0 and has a thicker wall.

- 5.2 Only Perfection PERMASERT/PERMASERT 2.0 stab fittings are approved at Ameren Illinois (AIC). See [Appendix A - Stab Fittings](#). As the supply of Permasert fittings are depleted they are being replaced by Permasert 2.0 fittings.
- 5.3 Use the appropriate chamfering tool to chamfer the PE pipe end. See Table below ([Section 6.0](#)) for chamfering tools stock code numbers.
 - 5.3.1 Permasert 2.0 fittings require chamfering both the outer and inner surface of the pipe. Only the Permasert 2.0 chamfering tool is designed to perform that task.
 - 5.3.2 The dual size Permasert chamfering tool only chamfers the outer pipe surface and **cannot** be used for Permasert 2.0 fittings.
 - 5.3.3 The Permasert 2.0 chamfering tool can be used to chamfer pipe ends for the older Permasert fittings.

6.0 Perfection PERMASERT/PERMASERT 2.0

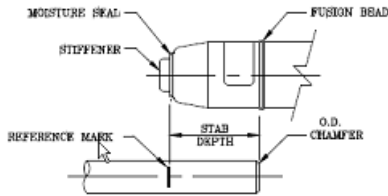
Procedure	Permasert	Permasert 2.0
Clean Pipe	Wipe clean with dry cloth	Wipe clean with dry cloth
Pipe Preparation	Square Cut Pipe	Square Cut Pipe
Inspect Pipe End, minimum 6" from end	Inspect for scratches or gouges	Inspect for scratches or gouges
Damage Found:	Remove and start over	Remove and start over
Chamfer End of Pipe	<p><i>Chamfer Tool: Stock Code Perfection Tool</i></p> <p>85 36 200 for 1/2" & 1" CTS 85 36 219 for 1/2" & 3/4" IPS OR <i>Honeywell Tool</i> 83 06 179 for 1/2" CTS 83 06 181 for 1" CTS 83 06 178 for 3/4" IPS Continue chamfering until tool bottoms out</p>	<p><i>Chamfer Tool: Stock Code Perfection Tool</i></p> <p>83 06 179 for 1/2" CTS 83 06 181 for 1" CTS 83 06 178 for 3/4" IPS Continue chamfering until tool bottoms out</p> <p>NOTE: Do not use Permasert tool to chamfer Permasert 2.0 fitting</p>

<p>Mark Stab Depth:</p>		<p>Mark when tool bottoms out</p> 
<p>If stab cap is used as a coupling, cut off the solid end</p>	<p>Using a plastic pipe cutter, cut on the dotted line to remove the solid end.</p>	<p>Using a plastic pipe cutter, cut on the dotted line to remove the solid end.</p>
<p>Mark Stab Depth:</p>	<p>Mark from fusion bead to cut</p>	
<p>Stab Pipe into Coupling</p>	<p>Reference mark should be within 1/8" of the moisture seal of the coupling.</p>	<p>Reference mark should be within 1/8" of the moisture seal of the coupling.</p>
<p>Pressure Test completed joint in accordance with PTST 1.1 Table A</p>	<p>Reference mark can move outward up to an additional 3/8" during pressure testing.</p>	<p>Reference mark can move outward up to an additional 3/8" during pressure testing.</p>

7.0 Compression Fittings

- 7.1 AIC approved compression fittings are installed above ground only.
- 7.2 AIC does not allow compression fittings to be installed below ground, but there are legacy fittings still in service.

End of Instructions.

Operator Qualification (OQ) Required?

YES

- 0641: Visually Inspect Pipe and Components Prior to Installation
- 0681: Joining of Plastic Pipe - Stab Fittings
- 0691: Joining of Pipe - Non-Bottom Out Compression Couplings
- 0701: Joining of Pipe - Bottom Out Compression Couplings
- 0711: Joining of Pipe - Compression Couplings

Appendices

[Appendix A - Stab Fittings](#)

Attachments

NONE.

Compliance Requirements

- 49 CFR §192.281 Plastic pipe.
- 49 CFR §192.283 Plastic pipe: Qualifying joining procedures.

UNCONTROLLED IF PRINTED

ASTM D2513 Standard Specification for Polyethylene (PE) Gas Pressure Pipe, Tubing, and Fittings

Reference Documents

Perfection Permasert Mechanical Couplings information available online [here](#).

Perfection Permasert 2.0 Gas Coupling information available online [here](#).

Document Rescission

POLY 2.6 Polyethylene Pipe: Mechanical Joining, October 1, 2021

Revision Notes

Location of Changes	Summary of Changes
Subsection 5.2 Paragraph 5.1.3	Remove "Use". Revised to - An electrofusion coupling is required to connect 1" CTS PE 4710 pipe to the service riser pigtail on 1" PE service lines.

Appendix A - Stab Fittings

The Permasert and Permasert 2.0 fittings listed below have the same stock code number. As the supply of Permasert fittings are depleted they are being replaced by Permasert 2.0 fittings.

A-1. Couplings: Permasert 2.0 (PE 4710)



Size	Wall Thickness (Inches)	Perfection Part No.	Stock No
1/2" CTS	0.090"	50101	19 17 139
1" CTS	0.099"	50103	19 17 285
1" IPS	0.119"	50601	19 17 152

A-2. Reducer Couplings - Permasert 2.0 (PE 4710)



Size	Wall Thickness (Inches)	Perfection Part No.	Stock No
3/4" IPS x 1/2" CTS	0.095" x 0.090"	50969	19 17 146
1" CTS x 1/2" CTS	0.099" x 0.090"	50149	19 17 299
1" CTS x 3/4" IPS	0.099" x 0.095"	50148	19 17 275

UNCONTROLLED IF PRINTED

1" IPS x 1/2" CTS	0.119" x 0.090"	50641	19 17 147
1" IPS x 1" CTS	0.119" x 0.090"	50623	19 17 301
1-1/4" IPS x 1" CTS	0.1660" x 0.099"	50192	19 17 274

A-3. End Caps - Permasert 2.0 (PE 4710)



Size	Wall Thickness (Inches)	Perfection Part No.	Stock No
1/2" CTS	0.090"	50016	19 17 135
3/4" IPS	0.095"	50026	19 17 136
1" CTS	0.099"	50045	19 17 300
1" IPS	0.119"	50612	19 17 137

A-4. Elbows - 90° - Permasert 2.0 (PE 4710)

Size	Wall Thickness (Inches)	Perfection Part No.	Stock No
1/2" CTS	0.090"	50294	19 17 314
1" CTS	0.099"	51333	19 17 312

A-5. Tees - Permasert 2.0 (PE 4710)

Size	Wall Thickness (Inches)	Perfection Part No.	Stock No
1/2" CTS	0.090"	50199	19 17 150
1" CTS	0.099"	50292	19 17 298

A-6. Repair Couplings: Permasert 2.0 (PE 4710)

Size	Wall Thickness (Inches)	Perfection Part No.	Stock No
1/2" CTS	0.090" x 12" Length	50199	19 17 295
1" CTS	0.099" x 18" Length	50292	19 17 296

1.0 Purpose

This document prescribes the requirements and procedures for evaluating damage to polyethylene (PE) pipe.

2.0 Scope

This document addresses the following:

[3.0 Target Audience](#)

[4.0 General](#)

[5.0 Pipe Pit Gauge](#)

[6.0 Maximum Defect Depth](#)

3.0 Target Audience

- Gas Engineering
- Gas Supervisors
- Gas Field Personnel
- Gas Construction Services Personnel

4.0 General

- 4.1 Any imperfection or damage found in a PE pipe segment shall be evaluated to determine whether it would impair the serviceability of the pipe.
- 4.2 Any nick, gouge or indentation that is greater than 10% of the PE pipe wall thickness is considered a defect and must be cut out.

5.0 Pipe Pit Gauge

- 5.1 A pipe pit gauge, digital or manual, shall be used to determine if more than 10% of the PE pipe wall thickness has been removed.
- 5.2 *Digital Pit Gauge*: Digital pit gauges shall be used and calibrated in accordance with the manufacturer's instructions. The accuracy of digital gauges shall be ± 0.001 inches.
 - 5.2.1 A couple of styles of digital gauges are pictured below (Figure 1). See [POLY 4](#).



Western Instruments N88-4-D



NDT Supply DPG-2

Figure 1: Digital Pit Gauges

5.2.2 Ordering information for these two pit gauges is shown in the Gas Standards & Procedures SharePoint site [here](#).

5.3 Manual Pit Gauge: A manual pit gauge typically used to measure corrosion pits on steel pipe can be used to measure defects in PE pipe. See Figure 2.

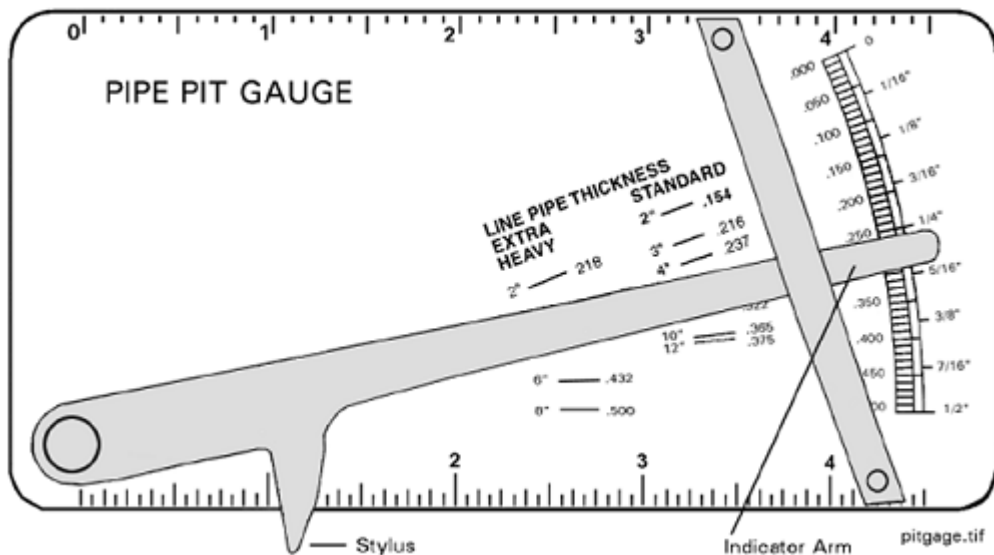

UNCONTROLLED IF PRINTED

Figure 2: Manual Pipe Pit Gauge (AG-1151, Stock Code 61 12 168)

5.3.1 Instructions

1. Clean area adjoining to the damage.
2. Place gauge lengthwise on the pipe and align with the center of the pipe.

To ensure accurate depth measurement, ensure that gauge is placed flush with the OD of the PE pipe, **not** on top of any flared polyethylene material that may have resulted from the damage.

3. Push the arm down until the stylus touches the pipe.
4. Read the depth indicated by the top of the indicator arm.
5. Measure damaged area until deepest cavity is found.

5.4 If depth of defect is greater than the maximum value listed in [Table 1](#), then remove the segment of PE pipe.

5.5 If measuring the depth of damage to plastic pipe is unsuccessful, then cut out and replace the damaged segment of PE pipe.

6.0 Maximum Defect Depth

6.1 Table 1 indicates the maximum defect depth for stock coded PE pipe sizes.

Table 1: Maximum Defect Depth

Pipe Size	PE 2406		PE 3408	
	Minimum Wall Thickness (inches)	Maximum Defect Depth (inches)	Minimum Wall Thickness (inches)	Maximum Defect Depth (inches)
½" CTS	0.090	0.009	0.090	0.009
1" CTS	0.099	0.009	0.101	0.010
1 ¼" IPS	0.166	0.017	Not applicable	Not applicable
2" IPS	0.216	0.022	0.216	0.022
3" IPS	0.304	0.030	Not applicable	Not applicable
4" IPS	0.391	0.039	0.409	0.041
6" IPS	0.576	0.058	0.602	0.060
8" IPS	0.639	0.064	Not applicable	Not applicable

End of Instructions.

Operator Qualification (OQ) Required?

YES

0641: Visually Inspect Pipe and Components Prior to Installation

1141: Squeeze Off Plastic Pipe

UNCONTROLLED IF PRINTED

Appendices

NONE.

Attachments

NONE.

Compliance Requirements

49 CFR §192.311 Repair of plastic pipe.

Reference Documents

NONE.

Document Rescission

POLY 2.07 Polyethylene Pipe: Evaluating PE Pipe Damage, January 1, 2016.

Revision Notes

Location of Changes	Summary of Changes
Not applicable.	This is a new document.

POLYETHYLENE PIPE

October 1, 2020

POLY 2.8 Sale of Polyethylene Pipe

1.0 Purpose

This document describes Ameren Illinois' (AIC) policy on third-party requests for polyethylene (PE) pipe.

2.0 Scope

This document addresses the following:

[3.0 Target Audience](#)

[4.0 General](#)

[5.0 Requests from the Public](#)

[6.0 Requests from Qualified Contractors, Other Gas Utilities or Municipals](#)

3.0 Target Audience

- Gas Field Personnel
- Gas Supervisors
- Gas Construction Services Personnel

4.0 General

4.1 To ensure safe operations, polyethylene pipe must be installed and tested by qualified personnel utilizing specialized tools and equipment.

5.0 Requests from the Public

5.1 AIC will **not** sell, donate, lend or otherwise transfer polyethylene pipe, including related fittings and materials, to the general public.

5.1.1 At the discretion of the Region Director, AIC may provide polyethylene materials and allow the use of equipment for charitable installations for civic groups, churches, etc. Donated polyethylene pipe and associated fittings must be installed by an employee qualified to install polyethylene pipe.

5.2 AIC will **not** lend or rent the tools and equipment used for joining polyethylene pipe.

5.3 AIC will **not** assist, advise, train or qualify private individuals in the techniques of joining or installing polyethylene pipe.

5.3.1 If asked, AIC Gas Supervisors or Gas Field Personnel may, to the extent of their knowledge, answer questions concerning sources of polyethylene pipe and qualified installers.

6.0 Requests from Qualified Contractors, Other Gas Utilities or Municipals

6.1 AIC maintains pipe and material inventories sufficient for its own needs.

6.2 On an emergency basis, AIC may sell polyethylene pipe and related fittings and materials to other gas utilities, municipal gas system operators, or to contractors known to have personnel qualified to join polyethylene pipe.

End of Instructions.

Operator Qualification (OQ) Required?

NO.

Appendices

NONE.

Attachments

NONE.

Compliance Requirements

NONE.

Reference Documents

NONE.

Document Rescission

POLY 2.08 Polyethylene Pipe: Sale of Polyethylene Pipe, January 1, 2014.

Revision Notes

Location of Changes	Summary of Changes
Not applicable.	This is a new document.

POLYETHYLENE PIPE

December 1, 2020

POLY 2.9 Plastic Fusion Qualification

1.0 Purpose

This document prescribes the requirements for qualification of Ameren Illinois (AIC) personnel to perform plastic fusion (heat fusion on polyethylene (PE) pipe) in accordance with 49 CFR §192.285.

2.0 Scope

This document addresses the following:

[3.0 Target Audience](#)[4.0 General](#)[5.0 Fusion Qualification](#)[6.0 Testing of Plastic Fusion Joints](#)[7.0 Regualification](#)[8.0 Records](#)**3.0 Target Audience**

- Gas Field Personnel
- Gas Supervisors
- Gas Construction Services Personnel

4.0 General

- 4.1 All gas field personnel performing plastic fusion must be trained and Operator Qualified (OQ) to make fusion joints.

5.0 Fusion Qualification

- 5.1 Fusion qualification shall be conducted under the supervision of the AIC Gas Operator Qualification Department.
- 5.2 Qualification will consist of a written exam and fabrication of specimen joints which are subjected to destructive testing.
- 5.3 A specimen joint shall be made by each Qualified Individual, as applicable, for each of the following fusion methods:
- 5.3.1 Butt Fusion-Manual
 - 5.3.2 Butt Fusion-Hydraulic
 - 5.3.3 Electrofusion-Coupling and Service Tee

6.0 Testing of Plastic Fusion Joints

- 6.1 The assembly of the specimen joint shall be observed to ensure that it is prepared in accordance with approved fusion procedures.
- 6.2 The completed fusion joint shall be examined visually and compared to a reference joint of acceptable quality.

UNCONTROLLED IF PRINTED

6.3 The following steps will be taken to test Butt Fusion Joints:

6.3.1 After allowing the joint to cool for a minimum of one hour, the joint shall be cut into three sample longitudinal straps, each approximately 1 inch wide.

6.3.2 Bend the sample straps by bringing the ends of the sample together and examine the entire fusion area.

1. A joint is considered satisfactory if all bent sample straps are completely free of cracks or voids in the fusion area.
2. If any separation, cracks, or voids are observed, then the fusion will be considered defective.

6.4 The following steps will be taken to perform a crush test on Electrofusion Joints:

6.4.1 Allow a minimum of one hour for joint to cool:

6.4.2 The following steps will be performed for testing coupling fusion joints:

1. Cut the pipe and coupling in half, as close as possible to the centerline of the pipe and coupling.
 - 1 a. *For pipe 2 inches and smaller:* It is desirable to have at least 3 inches of pipe at each end of the coupling.
 - 1 b. *For pipe larger than 2 inches:* It is desirable to have at least 8 inches of pipe at each end of the coupling.
2. Place a specimen half in a vise or hydraulic press so that the outermost wire of the fusion zone is approximately 1-1/4 inches from the jaws.
3. Close the jaws until the pipe walls meet.
4. Repeat the above process for each end of both halves of the coupling.
5. Inspect the crushed specimens for separation of the pipe and fitting in the fusion zone.
6. There should be no separation at the fusion interface of the pipe and fitting beyond the 15% at the outermost edges.

6.4.3 The following steps will be taken to perform a crush test on saddle fusion joints:

1. Leave the tapping tees intact.
2. Cut the pipe near the edge of the base of the saddle fitting.
3. Place the pipe and fitting into a vise or hydraulic press so that the jaws are within 1/2 inch of the bottom of the saddle.
4. Close the jaws until the inner pipe walls meet.
5. Inspect the crushed specimen for separation of the pipe and fitting in the fusion zone.
6. There should be no separation at the fusion interface of the pipe and fitting beyond the 15% at the outer most edges.

7.0 Requalification

7.1 All gas field personnel performing plastic fusion at AIC shall be requalified on each fusion method once per calendar year not to exceed 15 months.

- 7.2 Any gas field personnel who makes a production plastic pipe joint that is found to be unacceptable during pressure testing shall immediately report the failure to the Gas Supervisor.
 - 7.2.1 That individual shall **not** perform any additional plastic pipe joining until requalified in the failed process.
 - 7.2.2 The Gas Supervisor shall notify AIC Gas Operator Qualification Department to coordinate any remedial training needed, and requalification.

8.0 Records

- 8.1 Plastic fusion qualification will be recorded on the Plastic Fusion & Joining Annual Qualification form. See [POLY 4](#).
- 8.2 Plastic fusion qualification records shall be retained for a minimum period of 5 years.

End of Instructions.

Operator Qualification (OQ) Required?

YES

0751: Joining of Plastic Pipe-Butt Heat Fusion: Manual

0761: Joining of Plastic Pipe-Butt Heat Fusion: Hydraulic Machine

0781: Joining of Plastic Pipe-Electrofusion

Appendices

NONE.

Attachments

NONE.

Compliance Requirements

49 CFR §192.285 Plastic pipe: Qualifying persons to make joints.

Reference Documents

[POLY 4 Polyethylene Pipe: Forms and Reference Materials](#).

Performance Pipe PP-750, Heat Fusion Joining Procedures online reference [here](#).

ASTM F2620-19 - Standard Practice for Heat Fusion Joining of Polyethylene Pipe and Fittings

Document Rescission

POLY 2.9: Polyethylene Pipe: Plastic Fusion Qualification, October 1, 2020

Revision Notes

Location of Changes	Summary of Changes
Reference Documents	Updated reference link to Performance Pipe PP-750.

UNCONTROLLED IF PRINTED

POLYETHYLENE PIPE

October 1, 2020

POLY 2.10 Storage and Handling PE Material

1.0 Purpose

This document prescribes the storage and handling requirements for polyethylene (PE) material for use on natural gas systems.

2.0 Scope

This document addresses the following:

[3.0 Target Audience](#)

[4.0 Receipt Inspection](#)

[5.0 Handling](#)

[6.0 Unloading](#)

[7.0 Storage](#)

3.0 Target Audience

- Gas Field Personnel
- Gas Supervisors
- Gas Construction Services Personnel
- AIC Storeroom Personnel

4.0 Receipt Inspection

- 4.1 PE material shall be inspected upon receipt to verify the accuracy of the material and manufacture date and to ensure there is no damage.
- 4.2 Ameren Illinois (AIC) will not accept receipt of pipe that is more than 1 year past the manufacture date on the print line.
- 4.3 If the print line is not legible, the pipe shall not be accepted.
- 4.4 Print line designation for PE pipe shall include at least: PE 2708 for MDPE and PE 4710 for HDPE.
- 4.5 PE fittings shall have designations:
- 4.5.1 *MDPE*:
1. PE 2406/2708, or
 2. PE 2406, or
 3. PE 2708
- 4.5.2 *HDPE*:
1. PE 3408/4710, or
 2. PE 3408, or
 3. PE 4710

5.0 Handling

UNCONTROLLED IF PRINTED

- 5.1 PE pipe coils and silos can be stretch wrapped or strapped. Strapping shall be non-adhesive type plastic or other non-metallic material.
- 5.2 Unload and store PE pipe in an area that is relatively level.
- 5.3 Pipe should not be set down on gravel, rock or any other surface that could damage the pipe surface.
- 5.4 Do not use PE material that is damaged during handling, transportation or storage.

6.0 Unloading

- 6.1 Follow all applicable safety guidelines and procedures when unloading PE material.
 - 6.1.1 If PE material is not on a pallet, then use protective barrier to cover metal forks to transport or lift the pipe.
 - 6.1.2 When transporting or unloading pipe, take care to protect the pipe from dragging or scraping against the ground or sharp objects.
 - 6.1.3 Use fabric slings to unload PE material, if needed. Inspect slings before use.
 - 6.1.4 **Do not** use material handling equipment to push or pull the load off the trailer.
 - 6.1.5 **Do not** drop PE material.
- 6.2 Ensure the load has not shifted and will remain stable before removing the trucker's straps from the load.
 - 6.2.1 *Stick pipe is loose loaded:*
 1. Before moving the load, ensure chocks are secured to both ends of the timbers. If not, nail a chock or wedge into position.
 2. Untie and unload the individual pipe lengths.
 3. Position fork lift near the center of the pipe so that the pipe is balanced on the forks.
 4. Pipe ends shall not be dragged across the ground as it is being moved.
 - 6.2.2 *Stick pipe is bundled:*
 1. Check straps restraining the bundled pipe to ensure bundle is secure.
 2. If fork lift is used to remove the bundle:
 - 2 a. Position fork lift near the center of the bundle so that the bundle is balanced on the forks.
 - 2 b. Forks should be long enough to safely support the bundle.
 3. If crane is used to remove the bundle:
 - 3 a. Place slings at the balance point of the bundle.
 - 3 b. Tag lines may be connected to the end of the bundle to assist in controlling the removal and placement of the bundle.
 - 6.2.3 *Coiled pipe silo on pallet:*

A silo refers to a wrapped package of several individually wrapped coils of pipe. The silo is transported on a pallet.

1. Check to make sure the silo banding is not broken and silo is secured on pallet.
2. Forks should be long enough to safely support the pallet.
3. Move the pallet as a whole unit.
4. If the silo banding is broken:
 - 4 a. Unload each coil individually, or
 - 4 b. Strap the silo prior to moving the pallet.

7.0 Storage

7.1 PE pipe has limited shelf life.

7.1.1 *PE 2708 (MDPE)*: Shelf life shall not exceed 3 years from the manufacture date printed on the pipe.

7.1.2 *PE 4710 (HDPE)*: Shelf life shall not exceed 10 years from the manufacture date printed on the pipe.

7.2 Store and protect PE material from:

7.2.1 Heat sources, such as steam pipes, heaters or radiators.

7.2.2 Contact with chemicals, salts or any substance that can degrade the material.

7.2.3 Direct contact with sharp objects or abrasive surfaces that can damage the material.

7.3 Unbundled stick length PE pipe shall be stacked according to the manufacturer's guidelines.

7.4 **Do not** stack PE pipe silos higher than 8 feet.

End of Instructions.

Operator Qualification (OQ) Required?

NO.

Appendices

NONE.

Attachments

NONE.

Compliance Requirements

NONE.

Reference Documents

Plastic Pipe Institute - Material Handling Guide available online [here](#).

Document Rescission

POLY 2.10 Polyethylene Pipe: Storage and Handling PE Material, February 1, 2019.

Revision Notes

UNCONTROLLED IF PRINTED

Location of Changes	Summary of Changes
Not applicable.	This is a new document.

POLYETHYLENE PIPE

October 1, 2020

POLY 2.11 Maintenance of Fusion Equipment

1.0 Purpose

This document prescribes the general maintenance requirements for the electrofusion and butt fusion equipment used in heat fusion of PE pipe.

These general requirements meet the requirements of 49 CFR §192.756 and shall be used in conjunction with those published by equipment manufacturers.

2.0 Scope

This document addresses the following:

[3.0 Target Audience](#)

[4.0 Electrofusion Equipment Maintenance](#)

[5.0 Butt Fusion Machine Maintenance](#)

[6.0 Peelers](#)

[7.0 Clamps](#)

3.0 Target Audience

- Gas Engineering
- Gas Supervisors
- Gas Field Personnel
- Gas Construction Services Personnel

4.0 Electrofusion Equipment Maintenance

Under no circumstance shall the electrofusion processor enclosure be opened for service in the field by unauthorized personnel.

- 4.1 Maintenance work required on electrofusion processors shall be only performed by the manufacturer's authorized service personnel or service center. See [POLY 4](#) for manufacturers' manuals.
- 4.2 Electrofusion processors shall be maintained at intervals that meet the minimum requirements specified in manufacturer's instructions. Maintenance records shall be maintained in Maximo.
- 4.3 Perform the following inspection on a regular basis on equipment that is being used:
 - 4.3.1 Clean processor's housing with a damp cloth. **Do not** spray with water or compressed air.
 - 4.3.2 Clean processor digital display screens with industrial alcohol. **Do not** use solvents or Trichlor products.
 - 4.3.3 Inspect the power cables for damage and replace damaged cables.
 - 4.3.4 Inspect and clean fitting adapters.

UNCONTROLLED IF PRINTED

4.3.5 Ensure fitting adapters fit tightly. Replace loosely fitting adapters.

4.3.6 Keep barcode scanner wand clean.

4.3.7 Keep area around the sensors clean and free of obstructions.

4.4 Store processors in a clean, dry and protected environment.

5.0 Butt Fusion Machine Maintenance

5.1 Manufacturer's detailed maintenance procedures for the McElroy and Connectra machines can be found in [POLY 4](#).

5.2 The following are general maintenance procedures and should be performed on a regular basis on equipment that is being used:

5.2.1 Keep mechanical portion of the machine clean of mud and contaminating material.

5.2.2 Remove heater and facer before washing the machine.

5.2.3 Remove oily dirt build up on guide rods.

5.2.4 Lubricate guide rods if they are not self-lubricated.

5.2.5 Check pivot pins and shafts and apply a drop of oil.

5.2.6 Remove dirt from jaws and clamp knob.

5.2.7 Clean clamp knob eyebolt threads.

5.2.8 Check all nuts, bolts and snap rings to ensure they are secure and in place.

5.2.9 Check heater surfaces and clean if necessary.

5.2.10 Inspect facer blades for damage and sharpness. Replace damaged or dull blades.

5.2.11 Clean facer guides with clean dry cloth.

5.2.12 Check locking cam for wear and damage, if equipped.

5.3 The butt fusion machines will have an inspection performed every other year. The inspection will be recorded and tracked in Maximo.

6.0 Peelers

6.1 Peelers should be free of dirt and/or any substance that could contaminate the fusion area.

6.2 Inspect peeler blades for sharpness and damage. Replace if necessary.

6.3 Indication of dull or damaged blades may include:

6.3.1 Incomplete removal of witness markings.

6.3.2 Non-uniform thickness of ribbon material being removed.

6.3.3 Gouges in the peeled surface.

6.4 If applicable, check wheels to ensure they rotate smoothly and have not been damaged. Replace if necessary.

7.0 Clamps

7.1 Clamps should be clean.

7.2 Inspect clamps for damage and replace if necessary.

7.3 Ensure clamps are holding fitting securely in-place, replace if not.

End of Instructions.

Operator Qualification (OQ) Required?

NO.

Appendices

NONE.

Attachments

NONE.

Compliance Requirements

49 CFR §192.756 Joining plastic pipe by heat fusion; equipment maintenance and calibration.

Reference Documents

[POLY 4 Polyethylene Pipe: Forms and Reference Materials](#)

Document Rescission

POLY 2.11 Polyethylene Pipe: Maintenance of Fusion Equipment, October 1, 2019.

Revision Notes

Location of Changes	Summary of Changes
Not applicable.	This is a new document.

POLYETHYLENE PIPE

October 1, 2021

POLY 3.1 Transition Fittings and Protective Sleeves

1.0 Purpose

This document describes the requirements for:

- Transition fittings used to make plastic-to-steel connections
- Protective sleeves

2.0 Scope

This document addresses the following:

[3.0 Target Audience](#)[4.0 Transition Fittings](#)[5.0 Protective Sleeves](#)

Appendices

[Appendix A - Transition Fittings](#)[Appendix B - Protective Sleeves](#)

3.0 Target Audience

- Gas Engineering
- Gas Supervisors
- Gas Field Personnel
- Gas Construction Services Personnel

4.0 Transition Fittings

- 4.1 The use of transition fittings is the only approved method at Ameren Illinois (AIC) for making a plastic-to-steel connection. **The use of mechanical compression couplings is no longer approved.**
- 4.2 [Appendix A](#) shows transition fittings approved for use at AIC. Note that each fitting comes with a protective sleeve.
- 4.3 Installation
- 4.3.1 Weld the steel end of the fitting to steel pipe using an approved welding procedure.
- 4.3.2 Wrap the transition portion of the fitting with wet rags. Do not remove rags until the weld has cooled, approximately 10 minutes.
- 4.3.3 Position the protective sleeve over the transition portion of the fitting. If necessary, tape the sleeve in place.
1. Protective sleeve is required for fittings less than 2 inch.
 2. Protective sleeve is optional for fittings 2 inch and larger.

Protective sleeve shall be installed as one solid piece and not split in half.

UNCONTROLLED IF PRINTED

4.3.4 Make heat fusion weld to plastic pipe using approved procedures.

5.0 Protective Sleeves

5.1 [Appendix B](#) shows protective sleeves approved for use at AIC.

End of Instructions.

Operator Qualification (OQ) Required?

YES

0641: Visually Inspect Pipe and Components Prior to Installation

Appendices

[Appendix A - Transition Fittings](#)

[Appendix B - Protective Sleeves](#)

Attachments

NONE.

Compliance Requirements

49 CFR §192.281 Plastic pipe.

Reference Documents

NONE.

Document Rescission

POLY 3.1 Polyethylene Pipe: Transition Fittings and Protective Sleeves - April 1, 2021.

Revision Notes

Location of Changes	Summary of Changes
Paragraph 4.3.3 NOTE:	Added "solid" protective sleeve is to be installed as one solid piece and not split in half
Appendix B – Protec- tive Sleeve	Removed the 18 inch sleeve for 1.875" ID. Added "solid" protective sleeve is to be installed as one solid piece and not split in half.

Appendix A - Transition Fittings

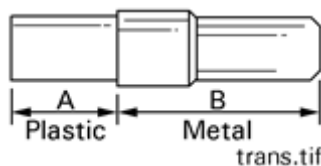

Central Plastics					
Nominal Pipe Size (inches)	Stock No.		A	B	Sleeve Length (inches)
	PE 2708	PE 4710			

UNCONTROLLED IF PRINTED

3/4" IPS x 1/2" CTS	Not applicable	19 22 373	12 1/8"	12 11/16"	12"
1" CTS	Not applicable	19 22 372	11 13/16"	12 7/8"	18"
1 1/4" IPS	19 17 302	Not applicable	12"	13 7/16"	18"
2" IPS	19 17 129	19 22 106	12 5/32"	13 3/4"	24"
3" IPS	19 17 130	Not applicable	14 7/8"	12"	28"
4" IPS	19 17 131	19 22 109	12 1/16"	14 7/8"	30"
6" IPS	19 17 132	19 22 111	17 7/16"	17 15/16"	36"
8" IPS	19 17 336	19 22 520	24 1/2"	22 1/2"	48"
12" IPS		19 22 514			

Appendix B - Protective Sleeves



Performance Pipe				
Inside Diameter (inches)	Sleeve Size	Sleeve Length (inches)	Performance Pipe Part Number	Stock No.
1.370"	PS1A	12"	1068669	19 83 158
1.525"	PS2	18"	1068682	19 83 159
1.875"	PS3	21"	1068685	19 22 423
2.375"	PS4	18"	1068686	19 83 161
2.875"	PS5	24"	1068689	19 83 191
4.250"	WPS6	30"	1047612	19 83 163
5.200"	WPS7	36"	1047613	19 83 164
7.708"	WPS8	36"	1047617	19 83 165

1. Protective sleeve shall be installed as one solid piece and not split in half.

UNCONTROLLED IF PRINTED

UNCONTROLLED IF PRINTED

POLYETHYLENE PIPE

April 1, 2023

POLY 4 Forms and Reference Materials

Click on the links below to open the documents.

Forms

1. [Plastic Fusion and Joining Annual Qualification](#)

References

1. [Easy Fuse Operations Manual](#)
2. [FRIAMAT Fusion Units Operating Instructions](#)
3. [Charlotte Electrofusion Processor Operating Manual](#)
4. [Shannon Electrofusion Processor Operating Manual](#)
5. [Danielle Electrofusion Processor Operating Manual](#)
6. [Diane Electrofusion Processor Operating Manual](#)
7. [Ktech-17 TL Electrofusion Processor Operating Manual](#)
8. [McElroy Mini-Mc Operator's Manual \(Rev 6/18\)](#)
9. [McElroy 2LC and Pit Bull 14 Operator's Manual \(Rev 10/18\)](#)
10. [McElroy 28 and 250 Fusion Machine Operator's Manual \(02/19\)](#)
11. [McElroy Pit Bull Hydraulic Fusion Machines Operator's Manual \(Rev 06/17\)](#)
12. [McElroy Pit Bull 26 Fusion Machine Operator's Manual \(Rev 10/18\)](#)
13. [Connectra 28EP Operator's Manual \(Rev 04/2011\)](#)
14. [Connectra 28HP Operator's Manual \(Rev 09/2018\)](#)
15. [Connectra 414SC Operator's Manual](#)
16. [Performance Pipe PP750 Heat Fusion Joining Procedures \(June 2021\)](#)
17. [McElroy TP 300 Series Test Cap \(08/2017\)](#)
18. [McElroy Line Tamer Manual for PE 3 thru 6 inch \(Rev 11/18\)](#)
19. [Condux Break Away D Drill Swivels Manual](#)
20. [GF Central Plastics MSA 340 Processor Operations Manual \(Nov 2014\)](#)
21. [IPEX Genesis F3 Electrofusion Processor Operator Guide \(Rev 14\)](#)
22. [Phoenix Battery Processor Model 804](#)
23. [Innogaz Installation Procedures](#)
24. [IPEX Friatec Installation Procedures](#)
25. [GF Central Plastics EF Installation Procedure Manual \(09/2017\)](#)
26. [G F Rotary Peeler RS Manual \(March 2015\)](#)
27. [Western Instruments Dial Pit Gauges Instruments 2007/Small](#)
28. [Western Instruments Pit Gauge Calibration](#)

UNCONTROLLED IF PRINTED

29. [NDP Supply - DPG Digital Pit Gauge User Manual](#)
30. [Footage C100-B001 Owner's Manual](#)
31. [Footage C156-A004 Owner's Manual](#)
32. [Footage C177 Owner's Manual](#)
33. [Footage C400 Owner's Manual](#)
34. [Footage C600-A002 Owner's Manual](#)
35. [Footage C850 Owner's Manual](#)
36. [GF Operator's Manual for Service, Mechanical & Hydraulic PolySqueez](#)
37. [Mustang DBS-24C Product Sheet](#)
38. [Mustang GLS-26 Operating Procedures Modified by AIC](#)
39. [Mustang GLS-26 Product Sheet Modified by AIC](#)
40. [Mustang DBGA-80 Product Sheet](#)
41. [Timberline TC1-S Instruction Manual Reformatted](#)
42. [Timberline TC2-S Instruction Manual Reformatted](#)
43. [Timberline TR 270 Instruction Manual Reformatted](#)
44. [Timberline TR 650 Instruction Manual Reformatted](#)
45. [Performance Pipe PP801 PE Pipe Squeeze-Off](#)
46. [Plastic Pipe Institute PPI TN 54 – 2017 Squeeze-Off of PE Pipe](#)
47. [SupraFlow Gas Tap Tee Specifications](#)

End of Section.

Document Rescission

POLY 4 Polyethylene Pipe: Forms and Reference Materials, October 1, 2022

Revision Notes

Location of Changes	Summary of Changes
Reference Documents	Updated Innogaz Installation Procedures Added – Supraflow Gas Tap Tee Specifications

UNCONTROLLED IF PRINTED

PRES-Pressure Monitoring

PRESSURE MONITORING

October 1, 2020

PRES 0 Table of Contents

[PRES 1 Pressure Monitoring: Requirements](#)

Section 1.0 Purpose

Section 2.0 Scope

Section 3.0 Target Audience

Section 4.0 General

Section 5.0 Pressure Monitoring Locations

Section 6.0 Pressure Monitoring as Early Warning Agent

Operator Qualification (OQ)

Compliance Requirements

Reference Documents

Document Rescission

[PRES 2.1 Pressure Monitoring: Potential Over Pressurization or Service Interruption](#)

Section 1.0 Purpose

Section 2.0 Scope

Section 3.0 Target Audience

Section 4.0 General

Section 5.0 Pressure Monitoring While Performing Work Activities

Section 6.0 Low Pressure Systems (4 inch to 14 inches water column)

Section 7.0 Gas Control

Section 8.0 Activities Requiring an Operational Checklist

Section 9.0 Activities Requiring an Operational Checklist and Written Procedure

Section 10.0 Overpressure Reporting

Operator Qualification (OQ)

Appendices

Appendix A - Sample Operation Checklist

Appendix B - Sample Written Procedure Outline

Compliance Requirements

UNCONTROLLED IF PRINTED

Reference Documents

Document Rescission

PRES 2.2 Pressure Monitoring: Pressure Recorders

Section 1.0 Purpose

Section 2.0 Scope

Section 3.0 Target Audience

Section 4.0 Electronic Recorders

Section 5.0 Mechanical Chart Recorders

Operator Qualification (OQ)

Compliance Requirements

Reference Documents

Document Rescission

PRES 2.3 Pressure Monitoring: ERX Alarm Change Request

Section 1.0 Purpose

Section 2.0 Scope

Section 3.0 Target Audience

Section 4.0 ERX Alarm Change Request

Section 5.0 Pressure Change Request to Pipeline Supplier

Operator Qualification (OQ)

Appendices

Appendix A - Sample Forms

Appendix B - Pressure Change Request Workflow Diagram

Compliance Requirements

Reference Documents

Document Rescission

PRES 3 Pressure Monitoring: Forms and Reference Materials

Forms

References

Document Rescission

End Table of Contents.

Document Rescission

PRES 4 Pressure Monitoring: Table of Contents, April 1, 2019.

Revision Notes

UNCONTROLLED IF PRINTED

Location of Changes	Summary of Changes
Not applicable.	This is a new document.

PRESSURE MONITORING

October 1, 2020

PRES 1 Requirements**1.0 Purpose**

This procedure outlines the requirements for monitoring the pressure in the Ameren Illinois (AIC) gas distribution and transmission systems to meet the requirements of Illinois Administrative Code Section 501.510 Pressure Surveys and 49 CFR §192.741 Pressure limiting and regulating stations: Telemetry or recording gauges.

2.0 Scope

This document addresses the following:

[3.0 Target Audience](#)**[4.0 General](#)****[5.0 Pressure Monitoring Locations](#)****[6.0 Pressure Monitoring as Early Warning Agent](#)****3.0 Target Audience**

- Gas Engineering
- Gas Field Personnel
- Gas Supervisors
- Gas Tech Services Personnel
- Gas Control Personnel
- Pipeline Integrity Management Personnel

4.0 General

- 4.1 Each gas distribution and transmission system has a defined maximum allowable operating pressure (MAOP).
- 4.2 Electronic pressure recorders, that continuously monitor pressure, shall be installed on those systems that require monitoring.

5.0 Pressure Monitoring Locations (49 CFR §192.741)

- 5.1 Install electronic pressure recording devices on:
- 5.1.1 Each distribution system supplied by *more than one* district regulator station.
- 5.1.2 Each distribution systems supplied by *a single* district regulator station **IF** the customer count, based on the most recent Gas Study, is in the range of 950 to 1100 customers and greater.
- 5.2 Location of pressure recording devices depends on the design of the system. Select locations that would best indicate an abnormal operating condition (AOC).

Recording devices can be installed at distribution regulator stations where transmission or high pressure distribution inlet pressures can be monitored along with outlet system pressure.

- 5.3 Gas Control monitors system pressures which have supervisory control data acquisition (SCADA) capability and Electronic Recorder (ERX) alarms.

UNCONTROLLED IF PRINTED

- 5.4 Additional recording devices (electronic recorders, manual chart recorders or pressure gauges) can be installed, at the discretion of the Gas Supervisor or at the request of Gas Tech Support or Gas Engineering, to identify suspected pressure control inadequacies or verify modeling results.
 - 5.4.1 Consider installing pressure recording devices at various locations within the distribution system to assist in maintaining system pressure within allowable limits.
 - 5.4.2 These pressure recording devices should remain until their purpose has been fulfilled.

The data compiled or derived from these recording devices will assist in determining the adequacy of system pressure control.

6.0 Pressure Monitoring as Early Warning Agent

- 6.1 Monitoring of pressure or flow can be used as an early warning agent to disclose system failures or malfunctions.
- 6.2 Consider the following parameters to determine whether monitoring of the system is feasible and practical:
 - 6.2.1 Response time of operating personnel to the source of the recording device.
 - 6.2.2 The magnitude of pressure drop or flow increase which would indicate a system failure.
 - 6.2.3 Design limits of the recording device to properly respond to a system failure.
 - 6.2.4 Recognition of possible failures to which the recording device would not respond.
 - 6.2.5 Seasonal changes in normal pressure or flow requirements, which will require Gas Technical Services (GTS) to provide Gas Control with new alarm limits.

End of Instructions.

Operator Qualification (OQ) Required?

YES

0311: Adjust and Monitor Flow or Pressure - Manual Valve Operation

1371: Operate Gas Pipeline - System Control Center Operations

1381: Operate Gas Pipeline - Local Facility Remote -Control Operations

A003: Emergency Response

Appendices

NONE.

Attachments

NONE.

Compliance Requirements

UNCONTROLLED IF PRINTED

Illinois Administrative Code Section 501.510 Pressure Surveys.

49 CFR §192.741 Pressure limiting and regulating stations: Telemetering or recording gauges.

Reference Documents

NONE.

Document Rescission

PRES 1 Pressure Monitoring: Requirements, January 1, 2018.

Revision Notes

Location of Changes	Summary of Changes
Not applicable.	This is a new document.

PRESSURE MONITORING

October 1, 2021

PRES 2.1 Potential Over Pressurization or Service Interruption**1.0 Purpose**

This procedure provides guidance response to potential over pressurization or service interruption. This procedure meets the minimum requirements of 49 CFR §191.23.

2.0 Scope

This document addresses the following:

[3.0 Target Audience](#)[4.0 General](#)[5.0 Pressure Monitoring While Performing Work Activities](#)[6.0 Low Pressure Systems \(4 inch to 14 inches water column\)](#)[7.0 Gas Control](#)[8.0 Activities Requiring an Operational Checklist](#)[9.0 Activities Requiring an Operational Checklist and Written Procedure](#)[10.0 Overpressure Reporting](#)

Appendices

[Appendix A - Sample Operation Checklist](#)[Appendix B - Sample Written Procedure Outline](#)**3.0 Target Audience**

- Gas Engineering
- Gas Field Personnel
- Gas Supervisors
- Gas Tech Engineering (GTE)
- Gas Tech Services Personnel (GTS)
- Gas Control Personnel
- Pipeline Integrity Management Personnel
- Gas Control

4.0 General

- 4.1 There are certain activities performed while operating and maintaining the gas system which present the potential for over pressurization or an unintentional interruption of gas service to our customers.
- 4.2 At a minimum these activities require pressure monitoring. However, some work activities warrant additional planning and written procedures.
- 4.3 This section identifies the activities that require pressure monitoring, an operational checklist and/or a written procedure prior to performing the work activity.

5.0 Pressure Monitoring While Performing Work Activities

- 5.1 Pressure monitoring shall be required when performing work activities that could result in an unintentional gas service outage or an over pressure situation above the maximum allowable operating pressure (MAOP) of the system.
- 5.2 Work activities that require pressure monitoring of the system include activities such as:

UNCONTROLLED IF PRINTED

- 5.2.1 Manual by-passing operations.
- 5.2.2 Isolating a regulator station.
- 5.2.3 Closing or opening system valves that depend upon a two-way feed to supply the system.
- 5.2.4 Increasing or decreasing normal system operating pressure.
- 5.2.5 Stopping or squeeze-off operations that depend upon a two-way feed to supply the system.
- 5.2.6 Installing pipe that connects two systems together.
- 5.2.7 Replacement work affecting a low pressure distribution gas system.
- 5.2.8 Regulator station maintenance work on a low pressure distribution gas system.
- 5.3 Pressure monitoring shall include:
 - 5.3.1 Installing pressure gauges or recording devices upstream and downstream of the work activities.
 - 5.3.2 Monitoring existing pressure chart recorders/gauges.
 - OR
 - 5.3.3 Requesting Gas Control to monitor electronic pressure recorders.

6.0 Low Pressure Systems (4 inch to 14 inches water column)

- 6.1 Pressure monitoring on low pressure system(s) requires a designated individual to constantly observe the downstream pressure during work activities. See Table 1 for low pressure systems within the Ameren Illinois (AIC) distribution network.

Table 1 - Low Pressure Systems

Town	System ID	System Name
Peoria	X436	Glen Brook Apartments

7.0 Gas Control

- 7.1 Contact Gas Control when planning and prior to beginning any major operation that could potentially:
 - 7.1.1 Affect the gas flow in a transmission or high pressure distribution main that is remotely monitored.
 - 7.1.2 Affect the operating pressures in a system.
 - 7.1.3 Result in an unintentional loss of gas service to a portion of a system.
- 7.2 Issues to discuss with Gas Control:
 - 7.2.1 Potential for the need to redirect gas flow.
 - 7.2.2 Will gas supply need to be obtained from a different supplier?
 - 7.2.3 Lead time required for necessary adjustments?
 - 7.2.4 Notify Gas Control of projected pressure limits and new alarm settings.
 - 7.2.5 Establish a communications plan between Gas Control and appropriate gas personnel at the jobsite.
- 7.3 Notify Gas Control when work has been completed.

UNCONTROLLED IF PRINTED

7.3.1 If applicable, notify Gas Control as to what alarm settings should be set, changed, or left as is.

7.3.2 If applicable, verify that the pressure readings at the monitored location are being accurately received by Gas Control

8.0 Activities Requiring an Operational Checklist

8.1 During the normal course of operating and maintaining the gas system, there are tasks performed which could temporarily interrupt the normal flow of gas.

8.2 The operational checklist form shall be used when performing the following tasks (See [PRES 3](#) and [Appendix A](#)):

8.2.1 Tapping and stopping performed on low pressure mains, distribution mains or transmission lines that will interrupt the normal flow of gas to customers.

8.2.2 Operating (opening or closing) system valves when performing scheduled construction or maintenance work that will interrupt the normal flow of gas.

8.2.3 Squeezing PE when performing scheduled construction or maintenance work that will interrupt the normal flow of gas.

8.2.4 When multiple tie-ins/cut-offs are required for system maintenance or replacement:

1. Gas Engineering shall develop a written sequence of operations to ensure actions taken will not affect system supply.
2. Gas Engineering shall review the construction sequence with the Gas Supervisor and the Construction Inspector where applicable.
3. If the scope of the field work changes, the plan shall be modified and approved by Gas Engineering.

8.3 The operational checklist is **not** required:

8.3.1 When there are no customers downstream of an operation such as squeezing and cutting off a cap in order to extend a main, or installing a stopper fitting to retire a section of main.

8.3.2 When performing Operational and Primary regulator station inspection.

8.3.3 When specific written sequence of operations is provided by engineering.

The operational checklist can be used in an emergency situation such as third party damage; however, it is not required.

9.0 Activities Requiring an Operational Checklist and Written Procedure

9.1 The following require an operational checklist and a written procedure:

9.1.1 Uprating system pressure. Refer to [UPRT 1](#) - Uprating.

1. Converting low pressure systems (4" to 14" w.c.) to distribution pressure.
2. Increasing the MAOP of a system.

9.1.2 Abandoning facilities. Refer to [ABND 2.1](#) for specific details.

UNCONTROLLED IF PRINTED

- 9.2 Gas Engineering personnel or GTE shall develop the written procedure. The Written procedure shall be approved by the Supervising Engineer or Gas Superintendent. See [Appendix B](#) for sample procedure outline.
- 9.3 The written procedure shall include the following:
- 9.3.1 Operational checklist.
- 9.3.2 Required information for the task being performed:
1. Abandonment plans. Refer to [ABND 2.1](#).
 2. Upgrading or increasing system pressure. Refer to [UPRT 1](#).
- 9.4 A pre-job meeting shall be held to review the written procedures.

10.0 Overpressure Reporting

10.1 Procedure

- 10.1.1 In case of any equipment malfunction or operating error that causes the pressure in a system to exceed the Maximum Emergency Pressure (MEP), the Gas Supervisor shall be verbally contacted immediately.
- 10.1.2 The Gas Supervisor will immediately contact:
1. Gas Compliance personnel and Gas Tech Services.
 2. Integrity Management group if a transmission system was over pressurized.
 3. See [FORW](#) for department contacts.
- 10.1.3 When the MEP is exceeded on transmission facilities, a Gas Transmission MAOP Exceedance Report must be filed with PHMSA within five calendar days of the occurrence. Refer to [SAFT 1](#).
- 10.1.4 GTS Supervisor shall contact Gas Control to see if affected system is remotely monitored.
1. If it is, have Gas Control review their data to verify an over-pressurization occurred. Gas Control shall provide GTS Supervisor with copy of available data to be included in the Gas Transmission MAOP Exceedance report.
- 10.1.5 The GTS Supervisor should also report the following information in writing to Manager - Pipeline Safety Compliance within three working days:
1. Date and times of occurrence.
 2. Names, job title and phone number of person(s) who determined the condition.
 3. Pressure system identification and station identification (including a physical address) if a regulator malfunction occurs.
 4. Normal operating pressure, MAOP and MEP of the system, and the highest actual pressures observed exceeding the MEP.
 5. Description of the overpressure protection devices and their operation.
 6. The apparent cause of the overpressure condition
 7. The corrective action taken (including reduction of pressure or shutdown) to date and any planned follow-up of future corrective action, including the anticipated schedule for starting and concluding such action.

UNCONTROLLED IF PRINTED

10.1.6 Gas Compliance shall notify PHMSA of the event by email to InformationResourcesManager@dot.gov and concurrently notify the Illinois Commerce Commission, Pipeline Safety Department, within five days of the occurrence.

10.1.7 When over-pressurization occurs within a transmission system, GTS Supervisor will provide Integrity Management group in Decatur with a copy of the Gas Transmission MAOP Exceedance report.

End of Instructions.

Operator Qualification (OQ) Required?

YES

0311: Adjust and Monitor Flow or Pressure - Manual Valve Operation

1371: Operate Gas Pipeline - System Control Center Operations

1381: Operate Gas Pipeline - Local Facility Remote -Control Operations

A003: Emergency Response

Appendices

[Appendix A - Sample Operation Checklist](#)

[Appendix B - Sample Written Procedure Outline](#)

Attachments

NONE.

Compliance Requirements

49 CFR §191.23 Reporting safety-related conditions.

Reference Documents

[FORW Forward](#)

[PRES 3 Pressure Monitoring: Forms and Reference Materials](#)

[UPRT 1 Uprating: Requirements](#)

Document Rescission

PRES 2.1 Pressure Monitoring: Potential Over Pressurization, October 1, 2020

Revision Notes

Location of Changes	Summary of Changes
Target Audience	Added Gas Control
Section 6.0 – Low Pressure Systems	Table 1 – Removed Belleville System ID 5150.

Appendix A - Sample Operation Checklist

[\(View/download PDF version\)](#)

UNCONTROLLED IF PRINTED

OPERATIONAL CHECKLIST TO MITIGATE THE OVER PRESSURIZATION OR UNINTENTIONAL INTERRUPTION OF GAS SERVICE

DOJM / WO # _____

Area Affected – Describe the area affected and consider the following:

- Main Segments
- Adjacent Gas Systems
- Customers Affected
 - o Residential
 - o Commercial
 - o Industrial
 - o Critical such as Hospital, School, Restaurants

(Details) _____

Isolation Points – Identify the location(s) where the normal flow will be interrupted:

- Tapping/Stopping
- System Valves
- Squeeze Off

(Details) _____

System Pressures – Identify the system MAOP, normal operating and the minimum pressure to maintain gas service.

- MAOP _____ Psig
- Normal Pressure _____ Psig
- Minimum Pressure _____ Psig

(Other Details for Multiple Systems) _____

Maintaining Flow – Identify the method(s) that will be utilized to supply gas to the area affected.

- By-Pass Installation
- By-Pass Through Stopper Equipment
- CNG Trailer
- Alternate System Feed
- Line Pack

(Details) _____

Pressure Monitoring – Identify method(s) to be utilized to monitor system pressure.

- Gauge Points
- Pressure Charts
- Electronic Recorders
- Gas Control/SCADA

(Details) _____

Pressure Monitoring Plan- Identify the location of pressure monitoring points including adjacent systems, the monitoring schedule, the expected pressures and acceptable range of pressure at each point. When establishing the monitoring plan consider the time of year, system loads, and system line pack.

1. Identify locations to monitor pressures
2. Identify expected pressures and acceptable ranges at each location(s)
3. Identify pressure monitoring scheduled (i.e. once, hourly, continuously, etc)
4. Record pressures during monitoring activities

Monitoring Point	Expected Pressure	Acceptable Range	Monitoring Schedule	Actual Pressure

(Details) _____

Public Notification – Identify public contacts to be notified prior to performing work activities.

- Fire / Police / City
- Residential Customers
- Commercial Customers
- Industrial Contact Center
- Critical Customers (i.e. Hospital, Nursing Home, School)
- Other _____

Contingency Action – Identify any contingency action(s) to be performed in the event of a high pressure or low pressure situation.

High Pressure

Low Pressure

Attach any additional documentation. Review and approval of the Gas Supervisor is required.

GAS SUPERVISOR _____ DATE _____ TIME _____

Appendix B - Sample Written Procedure Outline

[\(View/download PDF version\)](#)

WRITTEN PROCEDURES

DOJM / WR # _____

1. _____

2. _____

3. _____

4. _____

5. _____

6. _____

7. _____

8. _____

9. _____

10. _____

SUPERVISING ENGINEER _____ DATE _____

GAS SUPERINTENDENT _____ DATE _____

Final Verification that all written procedures have been performed prior to increasing system pressure.

NAME _____ DATE _____

UNCONTROLLED IF PRINTED

1.0 Purpose

This document provides procedures for reviewing electronic and mechanical pressure recorder data and responding to abnormal pressure results. This procedure meeting the requirements of 49 CFR §192.741.

2.0 Scope

This document addresses the following:

[3.0 Target Audience](#)

[4.0 Electronic Recorders](#)

[5.0 Mechanical Chart Recorders](#)

3.0 Target Audience

- Gas Engineering
- Gas Field Personnel
- Gas Supervisors
- Gas Tech Services Personnel (GTS)
- Gas Control Personnel
- Pipeline Integrity Management Personnel

4.0 Electronic Recorders

4.1 General

4.1.1 This section outlines procedures for using Electronic Recorders (ERX) for transmission and distribution systems. These procedures do not apply to the ERX's used for a different function at the gas storage fields. See Figure 1.



Figure 1: Mercury Electronic Recorder (ERX)

4.2 Reviewing Electronic Recorder Data

- 4.2.1 Gas Control shall monitor Electronic Recorder (ERX) and SCADA alarms.
- 4.2.2 Gas Control shall notify the Gas Technical Services (GTS) personnel, or Gas Supervisor and/or the pipeline supplier if the alarm notification system indicates a pressure outside the established pressure limits.

UNCONTROLLED IF PRINTED

4.2.3 The GTS technician shall investigate the situation and correct any deficiencies.

1. Notify Gas Control before starting any investigative work at the ERX or SCADA site.
2. Report corrective action taken to Gas Control and ensure alarm is cleared before leaving the ERX/SCADA site.

1. Historical data base with all of the recorder data is maintained in Gas Control's record system.
2. Gas Control sends out a weekly ERX Report to GTS Supervisors which lists alarms along with other operating data for each ERX being monitored in AIC operating areas.

4.2.4 The weekly ERX Report shall include a list of ERXs that are not communicating with the host computer.

1. GTS Supervisor shall dispatch GTS technician to the location to determine why the unit had lost communication and if possible, remedy the situation.
2. If the situation cannot be corrected at that time, the GTS technician shall collect and review weekly data until the unit resumes communicating with the host.

4.3 Calibration of Electronic Recorders.

4.3.1 Transmission and distribution system electronic pressure recorders shall be checked for accuracy and calibrated as necessary once each calendar year not to exceed 15 months.

4.3.2 Electronic pressure recorders shall be calibrated in accordance with manufacturer's instructions

4.3.3 The GTS Supervisors shall ensure the date of the calibration is documented in Maximo.

4.4 Records

4.4.1 Gas Control shall e-mail a weekly ERX Report GTS Supervisors and providing the following information from the previous week:

1. A summary of pressure readings;
2. Alarms;
3. Abnormalities recorded.

Gas Control maintains a historical electronic record or data base of recorded pressures for electronic pressure recorders.

4.4.2 The recorded pressure data shall be maintained for a minimum of two years.

5.0 Mechanical Chart Recorders

5.1 General

- 5.1.1 This section outlines procedures for using mechanical chart recorders.
- 5.1.2 Mechanical chart recorders are used to supplement electronic recorders for pressure monitoring in such instances as:
 - 1. An electronic recorder malfunctions and a replacement electronic recorder is not available.
 - 2. Pressure within the system needs temporarily monitored. Refer to [PRES 1 5.4](#).
- 5.1.3 Mechanical chart recorders are used as pressure recording devices. Refer to [PTST 1 Paragraph 8.1.2](#).

5.2 Changing Mechanical Recorder Charts

- 5.2.1 GTS personnel shall change the chart at the chart recording interval (i.e. daily or weekly).
 - 1. The following information shall be entered on the chart:
 - 1 a. Town and/or location of the chart recorder.
 - 1 b. Date and time when chart was installed.
 - 1 c. Date and time when chart was removed.
 - 1 d. Normal operating pressure.
 - 1 e. Initials of gas field personnel changing the chart.

5.3 Mechanical Chart Recorder Accuracy Check

- 5.3.1 Pressure recorders calibration shall be checked once each calendar year not to exceed 15 months.
- 5.3.2 The calibration checks shall be maintained in Maximo.
- 5.3.3 The calibration date shall be labeled on the chart recording device.
- 5.3.4 Pressure checks shall be made at zero and operating pressure, by comparison to an appropriate test gauge of known accuracy.
 - 1. If accuracy issues are detected, then take corrective action.

5.4 Records

- 5.4.1 The GTS Supervisor shall ensure the charts, for Mechanical chart recorders installed in regulator stations, are filed and retained for 2 years.

End of Instructions.

Operator Qualification (OQ) Required?

YES

0311: Adjust and Monitor Flow or Pressure - Manual Valve Operation

1371: Operate Gas Pipeline - System Control Center Operations

1381: Operate Gas Pipeline - Local Facility Remote -Control Operations

A003: Emergency Response

UNCONTROLLED IF PRINTED

Appendices

NONE.

Attachments

NONE.

Compliance Requirements

49 CFR §192.741 Pressure limiting and regulating stations: Telemetering and recording gauges.

Reference Documents

NONE.

Document Rescission

PRES 2.01 Pressure Monitoring: Mechanical Chart Recorders, January 1, 2013.

PRES 2.02 Pressure Monitoring: Electronic Recorders, October 1, 2019.

Revision Notes

Location of Changes	Summary of Changes
Not applicable.	This is a new document.

PRESSURE MONITORING

October 1, 2021

PRES 2.3 ERX Alarm Change Request

1.0 Purpose

This document provides instructions on making pressure change and ERX Alarm change requests.

2.0 Scope

This document addresses the following:

[3.0 Target Audience](#)

[4.0 ERX Alarm Change Request](#)

[5.0 Pressure Change Request to Pipeline Supplier](#)

Appendices

[Appendix A - Sample Forms](#)

[Appendix B - Pressure Change Request Workflow Diagram](#)

3.0 Target Audience

- Gas Tech Engineering (GTE)
- Gas Control
- GTS Supervisor
- Gas Tech Services (GTS) Superintendent
- Gas Tech Services (GTE) Technicians

4.0 ERX Alarm Change Request

4.1 General

4.1.1 AIC has electronic pressure recorders (ERX) installed at various locations throughout their operating areas that monitor operating pressure on various gas systems and facilities.

Many ERXs are programmed with alarm settings that are remotely monitored by Gas Control. The alarm settings provide an indication of possible problems within the system.

4.1.2 Gas Control has established protocols for addressing alarms and notifying the appropriate gas personnel to investigate. See [PRES 2.2](#).

Protocols are contained in Control Room Management Procedures maintained at Gas Control.

4.1.3 Gas Control shall not change any alarm setting without written approval by the appropriate GTS Supervisor/Superintendent or GTE Engineer.

UNCONTROLLED IF PRINTED

4.1.4 ERX alarm change request will be submitted electronically on Gas SCADA Alarm Limit Change Request form. See [Appendix A-2](#) and [PRES 3](#).

4.2 Alarm Change Request

4.2.1 Use the Gas SCADA Alarm Limit Change Request form to submit an alarm change request (temporary or permanent) to authorized Approver.

4.2.2 The Gas SCADA Alarm Limit Change Request form will handle one ERX.

4.2.3 The approved Gas SCADA Alarm Limit Change Request form should be submitted electronically to Outlook's @ERX by Approver.

4.2.4 Temporary pressure alarm change will be placed in an electronic file that alerts regularly until it is canceled by:

1. A follow-up Gas SCADA Alarm Limit Change Request to "return to normal alarm set-point"

OR

2. A new permanent alarm set-point request is received by @ERX.

4.2.5 Approved permanent alarm change will be loaded into the ERX database as the new alarm setting.

4.2.6 Only the authorized Approver should submit the completed Gas SCADA Alarm Limit Change Request electronically to Gas Control.

1. The Approver shall send the completed form under their e-mail sign-in as a means of documentation.

4.3 Situations Requiring Gas SCADA Alarm Limit Change Request Form

4.3.1 Operating pressure change may be needed to meet operational needs such as:

1. Tapping
2. System upgrades/downgrades
3. Pipeline repairs
4. Pipeline relocations
5. Maintenance on pressure control stations.

4.3.2 GTS personnel will know if these changes will be outside of the alarm settings for the ERX.

4.3.3 Activity requiring a change in operating pressure when the GTS personnel cannot remain on the jobsite.

1. Submit a completed and approved Gas SCADA Alarm Limit Change Request form to Gas Control before leaving the jobsite.

4.3.4 Activity requiring a change in operating pressure that extends beyond the GTS personnel's shift.

1. Submit a completed and approved Gas SCADA Alarm Limit Change Request form to Gas Control before the end of shift.

4.3.5 The Gas SCADA Alarm Limit Change Request can be completed in two ways:

1. GTS personnel can complete the form on their Mobile Data Terminal (MDT) and send it to their supervisor for approval

OR

2. GTS personnel can call their supervisor and have them complete the form.

4.4 Situations Not Requiring Gas SCADA Alarm Limit Change Request Form

- 4.4.1 GTS personnel are on the jobsite throughout the activity and are in contact with Gas Control before adjusting pressure and at the end of the activity to ensure a return to normal operating parameters.

Being on the jobsite does not require the Gas Technical Services personnel to be gauging pressure at each ERX location.

- 4.4.2 Activities such as calibration, inspection, or forcing a test call.
- 4.4.3 An activity where the adjusted operating pressure is within the ERX's alarm settings.
- 4.4.4 Performance of an activity that is not related to or causing an Abnormal Operating Condition (AOC). See [GLOS](#).

5.0 Pressure Change Request to Pipeline Supplier

5.1 General

- 5.1.1 Ameren Illinois (AIC) occasionally request Pipeline Suppliers to change the delivery pressure into the AIC gas system.

1. These changes could be due to an increase or decrease in demand or maintenance activities being performed in the system.

- 5.1.2 This section describes the formal process for requesting Pipeline Suppliers to change set point, temporarily or permanently, for gas being delivered into the AIC gas system.

5.2 Requests for Gas Suppliers to Change Set Points

- 5.2.1 GTS Superintendent shall review and approve requests for a Pipeline Gas Supplier to change pressure set points for gas delivered to AIC.
- 5.2.2 GTS personnel shall coordinate evaluation of the request with Gas Control, GTE, and Planning.
- 5.2.3 Gas Operations Support personnel shall prepare the Ameren Pressure Change Request form. See [PRES 3](#).
- 5.2.4 GTS Superintendent shall approve and electronically submit the Ameren Pressure Change Request to the appropriate Pipeline Supplier.
 1. Pipeline Supplier shall not make any changes to delivery pressure without this written approval from the GTS Superintendent.
- 5.2.5 Pipeline Supplier shall review, sign and electronically return the Ameren Pressure Change Request which validates the Supplier's actions in accordance with AIC's request.
- 5.2.6 If the requested change is temporary, then a subsequent Ameren Pressure Change Request shall be submitted to the Pipeline Supplier to reinstate normal delivery pressure setting.

UNCONTROLLED IF PRINTED

5.2.7 GTS shall provide, at a minimum, the following information on the Ameren Pressure Change Request form (see [Appendix A-1](#) and [PRES 3](#)):

1. Location name and address of the pipeline delivery point
2. Pipeline Supplier;
3. AIC representative;
4. Effective date for changing set point;
5. If the change is permanent or temporary;
6. If change is temporary, estimated duration of change;
7. Current AIC system MAOP;
8. Newly established AIC system MAOP, if applicable;
9. Current operating pressure;
10. Requested operating pressure.

5.2.8 GTS Superintendent shall distribute copies of completed Ameren Pressure Change Request form to:

1. Gas Control
2. GTE - Planning
3. GTE - Engineering
4. GTE - Operations

5.2.9 The workflow diagram in [Appendix B](#) outlines this process.

5.3 Records

5.3.1 GTS Superintendent shall see that all Ameren Pressure Change Request forms signed by the Pipeline Supplier are filed in a central file maintained by GTS.

End of Instructions.

Operator Qualification (OQ) Required?

YES

1371: Operate Gas Pipeline - System Control Center Operations

1381: Operate Gas Pipeline - Local Facility Remote -Control Operations

Appendices

[Appendix A - Sample Forms](#)

[Appendix B - Pressure Change Request Workflow Diagram](#)

Attachments

NONE.

Compliance Requirements

NONE.

UNCONTROLLED IF PRINTED

Reference Documents

[PRES 3 Pressure Monitoring: Forms and Reference Materials](#)

[GLOS Glossary](#)

Document Rescission

PRES 2.3 Pressure Monitoring: ERX Alarm Setting Change Request, October 1, 2020

Revision Notes

Location of Changes	Summary of Changes
2.0 Scope	Appendix A - Gas SCADA Alarm Limit Change Request Form
Throughout document	Gas SCADA Alarm Limit Change Request Form replaces ERX Alarm Set Point Change Request form
Paragraph 4.2.2 – ERX Alarm Change Request	SCADA Alarm Change Request will handle 1 ERX.
Operator Qualifications	Added: 1371 Operate Gas Pipeline – System Control Center Operations 1381 Operate Gas Pipeline – Local Facility Remote -Control Operations
Appendix A	New copy of Gas SCADA Alarm Limit Change Request Form

Appendix A, Sample Forms

A-1. Ameren Pressure Change Request Form

[\(View/download PDF version\)](#)



January 1, 2014

Ameren Pressure Change Request

Date Requested _____

Location Name _____

Address _____

GPS Coordinates _____

Pipeline Supplier: PEPL Trunkline ANR
 Midwest MRTC NGPL
 TETCO Texas Gas Northern Border
 OTHER _____

Pipeline Contact _____

Ameren Representative _____

Effective Date _____

Pressure Increase

Pressure Decrease

Temporary
 Approximate Duration _____

Permanent

Current Ameren System MAOP (PSIG) _____

Current Documented Delivery Pressure (PSIG) _____

Requested Pressure Change (PSIG) _____

Newly Established Delivery Pressure (PSIG) _____

Newly Established Ameren MAOP (PSIG) _____

Ameren Review: Superintendent Gas Technical Services

Supplier Verification: Ameren's pressure change request has been received and pressure changes have been implemented per this document.
 Date Implemented _____

Supplier will receive an additional pressure change request form prior to returning any temporary pressure change requests to their normal delivery pressure.

Please return to Ameren via reply email. Your electronic signature validates your companies' actions pursuant to Ameren's pressure change request.

Note: Pipeline supplier is responsible for the upgrade procedures relevant to their owned facilities which includes, but are not limited to piping, fittings, transducers, meters, heaters and other gas conditioning equipment.

cc: Gas Control
 Gas Technical Services - Planning
 Gas Technical Services - Engineering
 Gas Technical Services - Operations

A-2. Gas SCADA Alarm Limit Change Request Form

[\(View/download PDF version\)](#)

		Gas SCADA Alarm Limit Change Request	
Request Date:	08/04/2021		
Requestor's Name:			
Requestor's Title:			
Approved by:			
Approver's Title:			
SCADA Tag:			
SCADA Description	Storage Field Supervisor, Engineer, or Superintendent responsible for point being changed.		
	Current:	Change To:	
Severe or Emergency:	<input type="checkbox"/>	<input type="checkbox"/>	
High Caution:	<input type="checkbox"/>	<input type="checkbox"/>	
Low Caution:	<input type="checkbox"/>	<input type="checkbox"/>	
Severe or Emergency:	<input type="checkbox"/>	<input type="checkbox"/>	
Reason for Change:			
Proposed Date for Change:			
Is this a temporary change?		Anticipated Return to Normal Date:	
Gas Control Implementation			
Implemented By:			
Title:			
Date Implemented:			
Comments:	Insert Image of Face Plate after change.		
Temporary Alarms			
Actual Return to Normal:			
Authorized By:			
Implemented By:			
<small>Completed form to be distributed to Requestor, Approver, Division GTS or Storage Field Superintendent, Division GTS or Storage Field Supervisor, Division GTS or Storage Field Engineer, and Director Gas Control & Technical Services, Manager Gas Control Operations or, and Gas Control Specialist following implementation.</small>			

Appendix B - Pressure Change Request Workflow Diagram

[\(View full-size PDF version\)](#)

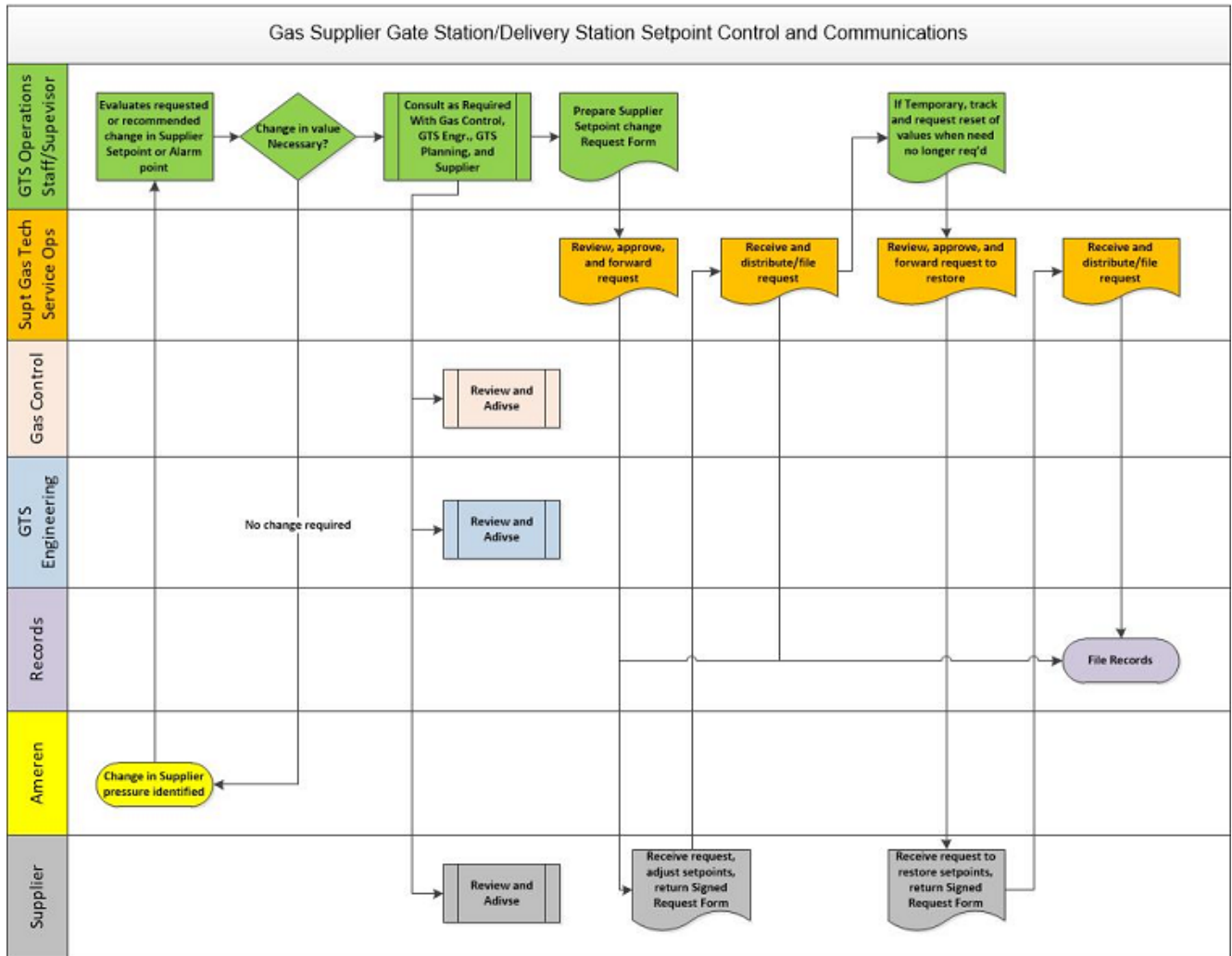

PRESSURE MONITORING

October 1, 2021

PRES 3 Forms and Reference Materials

Click on the links below to open the documents.

Forms

1. [Operational Checklist](#)
2. [Written Procedures Form](#)
3. [Gas SCADA Alarm Limit Change Request Form](#)
4. [Ameren Pressure Change Request](#)

References

1. [Mercury Instruments ERX Recorder User Guide](#)

End of Section.

Document Rescission

PRES 3 Pressure Monitoring: Forms and Reference Materials, October 1, 2020

Revision Notes

Location of Changes	Summary of Changes
Forms	New Gas SCADA Alarm Limit Change Request Form replaces ERX Alarm Change Request Form

PTRL-Pipeline Patrols

PIPELINE PATROLS

October 1, 2020

PTRL 0 Table of Contents

[PTRL 1 Pipeline Patrols: Requirements](#)

- Section 1.0 Purpose
- Section 2.0 Scope
- Section 3.0 Target Audience
- Section 4.0 Critical Area Patrols
- Section 5.0 Transmission Line Patrols (49 CFR §192.705)
- Section 6.0 Distribution Patrols (49 CFR §192.721)
- Section 7.0 Patrol Methods
- Section 8.0 Records
- Operator Qualification
- Compliance Requirements
- Reference Documents
- Document Rescission

[PTRL 2.1 Pipeline Patrols: Transmission Patrols](#)

- Section 1.0 Purpose
- Section 2.0 Scope
- Section 3.0 Target Audience
- Section 4.0 General
- Section 5.0 Transmission Main Patrol
- Section 6.0 Patrol Requirements
- Section 7.0 Processing Data
- Operator Qualification
- Compliance Requirements
- Reference Documents
- Document Rescission

[PTRL 2.2 Pipeline Patrols: Critical Area Patrols](#)

- Section 1.0 Purpose
- Section 2.0 Scope

UNCONTROLLED IF PRINTED

- Section 3.0 Target Audience
- Section 4.0 General
- Section 5.0 Critical Areas
- Section 6.0 Critical Area Patrols
- Section 7.0 Reporting and Documentation
- Section 8.0 Records
- Operator Qualification
- Compliance Requirements
- Reference Documents
- Document Rescission

PTRL 2.3 Pipeline Patrols: Patrol Methods

- Section 1.0 Purpose
- Section 2.0 Scope
- Section 3.0 Target Audience
- Section 4.0 General
- Section 5.0 Foot Patrol (Walking)
- Section 6.0 Vehicular Patrol (Driving)
- Section 7.0 Aerial Patrol (Flying)
- Section 8.0 Other Means
- Operator Qualification
- Compliance Requirements
- Reference Documents
- Document Rescission

End Table of Contents.

Document Rescission

PTRL 0 Pipeline Patrols: Table of Contents, January 1, 2016.

Revision Notes

Location of Changes	Summary of Changes
Not applicable.	This is a new document.

1.0 Purpose

This document prescribes requirements and frequency for patrolling gas transmission, high pressure distribution, and distribution pipelines in Ameren Illinois' (AIC) operating areas.

2.0 Scope

This document addresses the following:

[3.0 Target Audience](#)

[4.0 Critical Area Patrols](#)

[5.0 Transmission Line Patrols \(49 CFR §192.705\)](#)

[6.0 Distribution Patrols \(49 CFR §192.721\)](#)

[7.0 Patrol Methods](#)

[8.0 Records](#)

3.0 Target Audience

- Gas Compliance Personnel
- Gas Engineering
- Gas Supervisors
- Gas Field Personnel
- Contract Leak Surveyor
- Gas Integrity Management Personnel
- Gas Tech Engineering (GTE) Personnel
- Gas Storage Field Supervisors
- Gas Storage Field Personnel
- Gas Construction Services Supervisors

4.0 Critical Area Patrols

- 4.1 See [PTRL 2.2](#) for definition of critical areas and patrolling and recordkeeping procedures.
- 4.2 Critical areas on transmission, high pressure distribution, and distribution pipelines shall be identified and maintained in Maximo.
- 4.3 [Table 1](#) prescribes frequency and intervals between Critical Area Patrols.
- 4.3.1 *Business Districts*: Critical areas identified on transmission, high pressure distribution or distribution pipelines in business districts shall be patrolled a minimum four times each calendar year at intervals not exceeding 4 1/2 months.
- 4.3.2 *All other critical areas*: Critical areas identified on transmission, high pressure distribution or distribution pipelines shall be patrolled a minimum two times per calendar year at intervals not exceeding 7 1/2 months.

Table 1: Frequency of Critical Area Patrols

Location	Frequency
Critical areas within a Business District	Four times per calendar year; maximum interval of 4 1/2 months

All other critical areas	Two times per calendar year; maximum interval of 7 1/2 months
--------------------------	---

5.0 Transmission Line Patrols (49 CFR §192.705)

- 5.1 AIC shall have a patrol program to observe surface conditions on and adjacent to the transmission line right-of-way for indications of leaks, construction activity, and other factors affecting safety and operations. Refer to [PTRL 2.1](#) for transmission line patrolling methods, reporting and documentation.
- 5.2 Frequency and intervals between transmission patrols may not exceed those prescribed in Table 2, in accordance with 49 CFR §192.705.

Table 2: Frequency and Maximum Interval Between Transmission Patrols

Class Location	At Highway or Railroad Crossings	All Other Locations
1	Two times per calendar year; maximum interval of 7 1/2 months	One time per calendar year; maximum interval of 15 months
2	Two times per calendar year; maximum interval of 7 1/2 months	One time per calendar year; maximum interval of 15 months
3	Four times per calendar year; maximum interval of 4 1/2 months	Two times per calendar year; maximum interval of 7 1/2 months
4 Note (1)	Four times per calendar year; maximum interval of 4 1/2 months	Four times per calendar year; maximum interval of 4 1/2 months
<p>Notes:</p> <p>(1) AIC does not have any Class 4 Locations within its operating areas.</p> <p>(2) AIC will conduct patrolling for a pipeline in a tunnel at intervals similar to a pipeline in a casing.</p>		

- 5.3 For critical areas identified on transmission pipelines, see [Section 4.0](#) for Critical Area Patrols requirements and patrol frequency.

6.0 Distribution Patrols (49 CFR §192.721)

- 6.1 Distribution mains in places or on structures where anticipated physical movement or external loading could cause failure or leakage shall be patrolled. See Table 3.

Table 3: Frequency of Distribution Patrols (Non-Critical Areas)

Location	Frequency
Areas within a Business District	Four times per calendar year; maximum interval of 4 1/2 months
Areas outside of the Business District	Two times per calendar year; maximum interval of 7 1/2 months

- 6.2 For critical areas identified on distribution and high-pressure distribution pipelines, see [Section 4.0](#) for Critical Area Patrols requirements and patrol frequency.

7.0 Patrol Methods

- 7.1 Refer to [PTRL 2.3](#) for patrol methods. Transmission and distribution lines can be patrolled by:
 - 7.1.1 Walking the line, or
 - 7.1.2 Driving along the line, or
 - 7.1.3 Aerial patrol (flying) over the pipeline alignment, or
 - 7.1.4 Other appropriate means of traversing the right-of-way.

8.0 Records

- 8.1 The results of the pipeline facility patrols shall be updated following a patrol and maintained in Maximo. See Table 4 for record retention requirements.

Table 4: Record Retention

Facility	Retention
Transmission Mains	Life of the facility
High Pressure Distribution Mains (Critical areas)	6 years
High Pressure Distribution and Distribution Mains (Critical areas)	6 years

End of Instructions.

Operator Qualification (OQ) Required?

YES

1311: Inspect Pipe Surface Conditions: Patrol Right of Way or Easement

Appendices

NONE.

Attachments

NONE.

Compliance Requirements

- 49 CFR §192.705 Transmission lines: Patrolling.
- 49 CFR §192.709 Transmission lines: Record keeping.
- 49 CFR §192.721 Distribution systems: Patrolling.

Reference Documents

- [PTRL 2.1 Pipeline Patrols: Transmission Line Patrols](#)
- [PTRL 2.2 Pipeline Patrols: Critical Area Patrols](#)
- [PTRL 2.3 Pipeline Patrols: Patrol Methods](#)

Document Rescission

PTRL 1 Pipeline Patrols: Requirements, July 1, 2020.

Revision Notes

Location of Changes	Summary of Changes
Not applicable.	This is a new document.

PIPELINE PATROLS

October 1, 2020

PTRL 2.1 Transmission Patrols

1.0 Purpose

This document specifies procedures for gas transmission pipeline patrols, data processing and recordkeeping.

All procedures meet minimum requirements of 49 CFR §§ 192.705 and 192.709.

2.0 Scope

This document addresses the following:

[3.0 Target Audience](#)[4.0 General](#)[5.0 Transmission Main Patrol](#)[6.0 Patrol Requirements](#)[7.0 Processing Data](#)**3.0 Target Audience**

- Gas Compliance Personnel
- Gas Engineering
- Gas Supervisors
- Gas Field Personnel
- Contract Leak Surveyor
- Gas Integrity Management Personnel
- Gas Tech Engineering (GTE)
- Gas Tech Services (GTS) Supervisors
- Gas Tech Services (GTS) Personnel
- Gas Storage Field Supervisors
- Gas Storage Field Personnel
- Gas Construction Services Supervisors

4.0 General

- 4.1 The purpose of pipeline patrols is to observe surface conditions on and adjacent to pipeline rights-of-way for indications of leaks, encroachments, construction activity other than that performed by Ameren Illinois, and any other factors affecting safety and operation of the AIC pipeline.
- 4.2 Any indication of gas leakage must be investigated in accordance with procedures in [LEAK 2.2](#).

5.0 Transmission Main Patrol

- 5.1 Acceptable methods include:
 - 5.1.1 Walking.
 - 5.1.2 Driving.
 - 5.1.3 Aerial.
 - 5.1.4 Other appropriate means of traversing the right-of-way.
- 5.2 At least one transmission line patrol per calendar year shall be a land patrol.
- 5.3 Class locations, HCA's, MCA's, and patrol designation will be stored on the appropriate electronic maps.

UNCONTROLLED IF PRINTED

- 5.4 See [PTRL 1 Table 2](#) for transmission patrol frequency.
- 5.5 Pipeline facility patrols and critical area patrols may be performed in conjunction with the leak surveys. However, they must be documented separately within ClickMobile for their respective tasks.

6.0 Patrol Requirements

- 6.1 The following items, at a minimum, should be observed when performing the patrol by foot, vehicle, or aerial within the class location and class location buffer. See [PTRL 2.3](#) for additional items.
 - 6.1.1 Surface conditions on and adjacent to the pipeline facility right-of-way.
 - 6.1.2 Status of vegetation and tree growth within and adjacent to the pipeline right-of-way.
 - 6.1.3 Potential obstructions for accessibility to pipeline.
 - 6.1.4 Exposed transmission pipeline segments.
 - 6.1.5 Construction or recent excavation activities other than those performed by Ameren Illinois.
 - 6.1.6 Structures located over the pipeline.
 - 6.1.7 Demolition activities over or adjacent to pipeline.
 - 6.1.8 Visual indications of leaks.
 - 6.1.9 The presence of gas at casing vents and the general condition of highway and railroad crossings.
 - 6.1.10 Any condition that is or could be detrimental to the pipeline facilities.
 - 6.1.11 Any indication of hazardous or potentially hazardous conditions
 - 6.1.12 Construction activities such as a new subdivision, school, or business that may change the class location, MCA's, or HCA's along a transmission main.
- 6.2 Document within ClickMobile any condition that requires immediate notification to Gas Supervisor and follow-up action, such as:
 - 6.2.1 Hazardous or potentially hazardous conditions.
 - 6.2.2 Indication of gas coming from casing vents. If noted, then initiate a leak investigation within ClickMobile.
 - 6.2.3 Potential of structure located over pipeline ("over build") that has not been previously reported and investigated.
 - 6.2.4 Inaccessible segments of transmission line due to flooding, vegetation, difficult terrain, etc.

If completion of the transmission patrol is anticipated to be delayed beyond the compliance date due to inaccessibility, then notify Gas Compliance prior to the compliance date for special consideration.

- 6.3 Document within ClickMobile locations:

- 6.3.1 Exposed transmission pipeline segment(s) are observed.
- 6.3.2 Pipeline markers need to be installed or replaced.
- 6.3.3 Pipeline markers or signs that need correct Company name and phone number information. See [PMRK 1](#).
- 6.3.4 Atmospheric corrosion needing corrective action.
- 6.3.5 Casing vents need repair.
- 6.3.6 Casing vents need bug screens or warning signs replaced.
- 6.3.7 Corrosion control test station has been damaged.
- 6.3.8 Areas needing mowing and/or vegetation removal.
- 6.3.9 Any other deficiencies in items listed in [PTRL 2.3](#) or that gas field personnel deem as requiring follow-up action.
- 6.3.10 Any corrective action taken during the patrol process.

7.0 Processing Data

- 7.1 Gas Supervisor will notify Gas Integrity Management and Gas Tech Engineering if any of the following are noted:
 - 7.1.1 New building construction or demolition of existing buildings which could indicate possible changes in class locations, MCA's, or HCA's.
 - 7.1.2 Exposed section transmission pipeline.
 - 7.1.3 Occurrences or deficiencies that might affect the serviceability of the transmission main.
- 7.2 Following a field review of Class Location/HCA/MCA study by Pipeline Integrity Management, changes in class location and patrol may require the reviewer to:
 - 7.2.1 Create new patrols for new transmission mains.
 - 7.2.2 Update existing patrols for new highway crossings.
 - 7.2.3 Update existing patrols frequency for class location changes from Class 1 or 2 to Class 3 or 4.
 - 7.2.4 Update maps/aerial photos to reflect a change in class location.
 - 7.2.5 Provide the new or updated patrols information to the appropriate personnel for updating main segment(s) attributes within the GTECH mapping system.
 - 7.2.6 Notify Gas Supervisor of updated class locations, MCA's, HCA's and requirements.
- 7.3 Document completed Pipeline Patrol tasks in ClickMobile and maintain in Maximo.
- 7.4 Document any deficiencies noted during the Pipeline Patrol in ClickMobile.
- 7.5 If available, compare the current patrol conditions against conditions observed on previous patrols.

End of Instructions.

Operator Qualification (OQ) Required?

YES

UNCONTROLLED IF PRINTED

1311: Inspect Pipe Surface Conditions - Patrol Right of Way or Easement

Appendices

NONE.

Attachments

NONE.

Compliance Requirements

49 CFR §192.705 Transmission lines: Patrolling.

49 CFR §192.709 Transmission lines: Record keeping.

Reference Documents

[LEAK 2.2 Leak Management: Outdoor Investigations](#)

[PTRL 1 Pipeline Patrols: Requirements](#)

[PTRL 2.3 Pipeline Patrols: Patrol Methods](#)

Document Rescission

PTRL 2.01 Pipeline Patrols: Transmission Patrols, July 1, 2020.

Revision Notes

Location of Changes	Summary of Changes
Not applicable.	This is a new document.

PIPELINE PATROLS

October 1, 2020

PTRL 2.2 Critical Area Patrols

1.0 Purpose

This document defines critical areas along transmission, high pressure distribution, and distribution pipelines in Ameren Illinois' (AIC) operating areas and specifies procedures for critical area patrols, reporting and documentation, and recordkeeping.

All procedures meet minimum requirements of 49 CFR §§ 192.705, 192.709 and 192.721.

2.0 Scope

This document addresses the following:

[3.0 Target Audience](#)[4.0 General](#)[5.0 Critical Areas](#)[6.0 Critical Area Patrols](#)[7.0 Reporting and Documentation](#)[8.0 Records](#)

3.0 Target Audience

- Gas Compliance Personnel
- Gas Engineers
- Gas Supervisors
- Gas Field Personnel
- Contract Leak Surveyor
- Gas Integrity Management Personnel
- Gas Tech Engineering (GTE)
- Gas Tech Services (GTS) Supervisors
- Gas Tech Services (GTS) Personnel
- Gas Storage Field Supervisors
- Gas Storage Field Personnel
- Gas Construction Services personnel

4.0 General

- 4.1 This section outlines critical areas along transmission, high pressure distribution and distribution pipeline segments that are required to be patrolled to ensure conditions have not deteriorated, putting the gas facilities in danger of damage or leakage, and the consequent hazards to public safety.
- 4.2 When performing the patrol, evaluate conditions which required classifying the patrol as critical to verify the condition or serviceability of the pipeline has not worsened.

5.0 Critical Areas

- 5.1 Critical areas along transmission, high pressure distribution and distribution pipeline include:
 - 5.1.1 Exposed segments of pipeline.
 - 5.1.2 Pipeline attached to bridges.
 - 5.1.3 Pipeline attached to structures where physical movement could cause failure or leakage.

- 5.1.4 Areas of external loading such as a rock quarry, strip mine, or gravel pit where heavy loaded trucks cross over pipeline facilities on unsupported gravel or dirt roads.
- 5.1.5 Pipeline within 100 feet of blasting operations.
- 5.1.6 Pipeline identified as exposed or undermined after periods of heavy rains or flooding.

6.0 Critical Area Patrols

- 6.1 See [PTRL 1](#) for patrol frequency of Critical Area Patrols. When critical areas are identified during leak surveys, a critical area patrol shall be created within 3 months and patrolled in accordance with the required intervals.

7.0 Reporting and Documentation

- 7.1 Document within ClickMobile any changes in conditions that could adversely affect the integrity of the gas facilities.
- 7.2 Notify Gas Supervisor of any changes in conditions where follow-up action is required.
- 7.3 Notify Gas Integrity Management and Gas Tech Engineering (GTE) when Critical Area Patrol(s) are needed for transmission and high-pressure distribution lines.
- 7.4 Contact Gas Compliance for assistance in creating a Critical Area Patrol when conditions listed above are discovered and are not covered by an existing Critical Area Patrol.
- 7.5 If available, compare the current condition with conditions noted on previous critical area patrols.

8.0 Records

- 8.1 Refer to [PTRL 1](#) for patrol record requirements.

End of Instructions.

Operator Qualification (OQ) Required?

YES

1311: Inspect Pipe Surface Conditions - Patrol Right of Way or Easement

Appendices

NONE.

Attachments

NONE.

Compliance Requirements

- 49 CFR §192.705 Transmission lines: Patrolling.
- 49 CFR §192.709 Transmission lines: Record keeping.
- 49 CFR §192.721 Distribution systems: Patrolling.

Reference Documents

[PTRL 1 Pipeline Patrols: Requirements](#)

UNCONTROLLED IF PRINTED

Document Rescission

PTRL 2.02 Pipeline Patrols: Critical Area Patrols, January 1, 2016.

Revision Notes

Location of Changes	Summary of Changes
Not applicable.	This is a new document.

PIPELINE PATROLS

October 1, 2020

PTRL 2.3 Patrol Methods

1.0 Purpose

This document describes methods for patrolling gas transmission, high pressure distribution, and distribution pipelines in Ameren Illinois' (AIC) operating areas.

All procedures meet minimum requirements of 49 CFR §§ 192.705, 192.709 and 192.721.

2.0 Scope

This document addresses the following:

[3.0 Target Audience](#)[4.0 General](#)[5.0 Foot Patrol \(Walking\)](#)[6.0 Vehicular Patrol \(Driving\)](#)[7.0 Aerial Patrol \(Flying\)](#)[8.0 Other Means](#)**3.0 Target Audience**

- Gas Compliance Personnel
- Gas Engineering
- Gas Supervisors
- Gas Field Personnel
- Contract Leak Surveyor
- Gas Integrity Management Personnel
- Gas Tech Engineering (GTE) Personnel
- Gas Tech Services (GTS) Supervisors
- Gas Tech Services (GTS) Personnel
- Gas Storage Field Supervisors
- Gas Storage Field Personnel
- Gas Construction Services Supervisors

4.0 General

4.1 Transmission and distribution lines can be patrolled by:

- 4.1.1 Foot patrol (walking the line), or
- 4.1.2 Vehicular patrol (driving along the line), or
- 4.1.3 Aerial patrol (flying over the pipeline alignment), or
- 4.1.4 Other appropriate means of traversing the right-of-way.

5.0 Foot Patrol (Walking)

5.1 Foot patrol consists of personnel walking along the route of the pipeline and inspecting the area for the following conditions, in addition to those listed in [PTRL 2.1](#):

- 5.1.1 Depressions caused by earth settling around pipeline.
- 5.1.2 Washouts at stream crossings or hillsides.
- 5.1.3 Highway and railroad crossing vents for gas leakage. Also check for missing vents, warning signs, and bug screens.

UNCONTROLLED IF PRINTED

- 5.1.4 Visual check of any atmospheric corrosion on above ground gas facilities associated with the pipeline, including farm taps.
- 5.1.5 Agricultural field tilling operations in vicinity of the pipeline.
- 5.1.6 Condition of line markers, correct Ameren Illinois identification, and correct phone number. See [PMRK 1](#).
- 5.1.7 Houses within 220 yards of pipeline or playgrounds, recreation areas, or buildings that are occupied by at least 20 people 5 days per week, 10 weeks per year, within 100 yards of pipeline.

6.0 Vehicular Patrol (Driving)

- 6.1 Pipelines can be patrolled by driving along the route or over the pipeline and observing the right-of-way for the following conditions, in addition to those listed in [PTRL 2.1](#):
 - 6.1.1 Depressions caused by earth settling around pipeline.
 - 6.1.2 Washouts at stream crossings or hillsides.
 - 6.1.3 Highway and railroad crossing vents for gas leakage. Also check for missing vents, warning signs, and bug screens.
 - 6.1.4 Visual check of any atmospheric corrosion on above ground gas facilities associated with the pipeline, including farm taps.
 - 6.1.5 Agricultural field tilling operations in vicinity of the pipeline.
 - 6.1.6 Condition of line markers, correct Ameren Illinois identification, and correct phone number. See [PMRK 1](#).
 - 6.1.7 Houses within 220 yards of pipeline or playgrounds, recreation areas, or buildings that are occupied by at least 20 people 5 days per week, 10 weeks per year, within 100 yards of pipeline.
- 6.2 Some lines will be patrolled by a combination of foot patrol and vehicular patrol.

7.0 Aerial Patrol (Flying)

- 7.1 An aerial patrol consists of low-level flying along the route of the pipeline and observing the right-of-way for the following conditions, in addition to those listed in [PTRL 2.1](#):
 - 7.1.1 Depressions caused by earth settling around pipeline.
 - 7.1.2 Washouts at stream crossings or hillsides.
 - 7.1.3 Agricultural field tilling operations in vicinity of the pipeline.
 - 7.1.4 Presence and condition of aerial line markers.
 - 7.1.5 Houses within 220 yards of pipeline or playgrounds, recreation areas, or buildings that are occupied by at least 20 people 5 days per week, 10 weeks per year, within 100 yards of pipeline.
- 7.2 Report all suspected, observed, or questionable conditions to the Gas Supervisor for follow-up investigation of existing maps or by foot patrol to determine if there has been a change that affects patrol designation or frequency.

8.0 Other Means

- 8.1 Other means may be taken to access the pipeline route which will enable the operator to inspect the right-of-way.

- 8.1.1 Drones may be used to remotely inspect the right-of-way in a similar manner as aerial patrol.
 - 8.1.2 ATV's could be used to inspect the right-of way in a similar manner as foot patrol.
 - 8.1.3 Water craft may be needed to patrol pipelines that are underwater, either permanently or intermittently.
 - 8.1.4 There could be other methods that would allow an operator to be able to inspect right-of-way condition along a pipeline.
- 8.2 Report all suspected, observed, or questionable conditions to the Gas Supervisor for follow-up investigation of existing maps or by foot patrol to determine if there has been a change that affects patrol designation or frequency.

End of Instructions.

Operator Qualification (OQ) Required?

YES

1311: Inspect Pipe Surface Conditions - Patrol Right of Way or Easement

Appendices

NONE.

Attachments

NONE.

Compliance Requirements

49 CFR §192.705 Transmission lines: Patrolling.

49 CFR §192.709 Transmission lines: Record keeping.

49 CFR §192.721 Distribution systems: Patrolling.

Reference Documents

[PMRK 1 Pipeline Markers: Requirements](#)

[PTRL 2.1 Pipeline Patrols: Transmission Patrols](#)

Document Rescission

PTRL 2.03 Pipeline Patrols: Patrol Methods, July 1, 2014.

Revision Notes

Location of Changes	Summary of Changes
Not applicable.	This is a new document.

PTST-Pressure Testing

PRESSURE TESTING

October 1, 2021

PTST 0 Table of Contents

PTST 1 Pressure Testing: Requirements

- Section 1.0 Purpose
- Section 2.0 Scope
- Section 3.0 Target Audience
- Section 4.0 General
- Section 5.0 Safety
- Section 6.0 Roles and Responsibilities
- Section 7.0 Test Medium
- Section 8.0 Test Recording Methods
- Section 9.0 Design MAOP
- Section 10.0 Testing
- Section 11.0 Plastic Pipe Testing
- Section 12.0 Tie-In Joints
- Section 13.0 Components and Fabricated Unit/Assemblies
- Section 14.0 Test Records
- Operator Qualification
- Compliance Requirements
- Reference Documents
- Document Rescission

PTST 1.1 Pressure Testing: Test Pressure and Duration Requirement Tables

- Appendix A - Service Lines, Less Than 2" Diameter; Plastic or Steel
- Appendix B - Plastic Main, All PE Pipe Sizes thru 12" with Design MAOP 125 psig or Less
- Appendix C - Steel Main, All Steel Pipe Sizes thru 18" with Design MAOP Less Than 100 psig
- Appendix D - Steel Main, All Steel Pipe Sizes thru 30" with Design MAOP 100 psig or Greater
- Appendix E - Fabricated Unit/Assembly or Short Section of Pipe
- Appendix F - Farm Tap, Single Cut, 60 to 450 psig Inlet Pressure

UNCONTROLLED IF PRINTED

Appendix G - Farm Tap, Double Cut, 451 to 1,000 psig Inlet Pressure

PTST 2.1 Pressure Testing: Leak Test

- Section 1 Purpose
- Section 2 Scope
- Section 3 Target Audience
- Section 4 General
- Section 5 Leak Test Duration
- Section 6 Leak Test Procedure
- Section 7 Leak Test Records
- Operator Qualification
- Compliance Requirements
- Reference Documents
- Document Rescission

PTST 2.2 Pressure Testing: Strength Test

- Section 1.0 Purpose
- Section 2.0 Scope
- Section 3.0 Target Audience
- Section 4.0 General
- Section 5.0 Test Medium
- Section 6.0 Strength Test Procedure
- Section 7.0 Strength Test Records
- Operator Qualification
- Compliance Requirements
- Reference Documents
- Document Rescission

PTST 2.3 Pressure Testing: Hydrostatic Pressure Testing

- Section 1.0 Purpose
- Section 2.0 Scope
- Section 3.0 Target Audience
- Section 4.0 General
- Section 5.0 Environmental Protection Requirements
- Section 6.0 Safety
- Section 7.0 Prior to Hydrostatic Testing
- Section 8.0 Filling with Water

Section 9.0 Pressurizing

Section 10.0 Depressurizing/Dewatering

Section 11.0 Spike Hydrostatic Pressure Test for Transmission Lines (49 CFR §192.506)

Section 12.0 Test Records

Operator Qualification

Compliance Requirements

Reference Documents

Document Rescission

PTST 2.4 Pressure Testing: Nitrogen Pressure Testing

Section 1.0 Purpose

Section 2.0 Scope

Section 3.0 Target Audience

Section 4.0 General

Section 5.0 Properties of Nitrogen

Section 6.0 Use of Compressed Gas Cylinder

Section 7.0 Cylinder Requirements

Operator Qualification

Compliance Requirements

Reference Documents

Document Rescission

PTST 2.5 Pressure Testing: MAOP Determination

Section 1.0 Purpose

Section 2.0 Scope

Section 3.0 Target Audience

Section 4.0 General

Section 5.0 MAOP for Steel or Plastic Pipelines (49 CFR §192.619)

Section 6.0 MAOP for High Pressure Distribution Systems

Section 7.0 MAOP for Low Pressure Systems

Section 8.0 Records

Section 9.0 Alternative MAOP for Certain Pipelines

Operator Qualification

Compliance Requirements

Reference Documents

Document Rescission

PTST 2.6 Pressure Testing: ASME Pressure Vessels

- Section 1.0 Purpose
- Section 2.0 Scope
- Section 3.0 Target Audience
- Section 4.0 Regulatory Requirement for ASME Pressure Vessels
- Section 5.0 Testing and Inspection Requirements
- Section 6.0 Temporary Installation
- Section 7.0 Temporary Removal from Service
- Section 8.0 Relocation of An Existing Pressure Vessel
- Section 9.0 Records
- Operator Qualification
- Compliance Requirements
- Reference Documents
- Document Rescission

PTST 3 Pressure Testing: Forms and Reference Materials

- Forms
- Document Rescission

End Table of Contents.

Document Rescission

PTST 0 Pressure Testing: Table of Contents, October 1, 2020.

Revision Notes

Location of Changes	Summary of Changes
PTST 1.1 Appendix B	Plastic Main – All PE Pipe Sizes thru 12" with Design MAOP 125 psig or Less
PTST 2.3 – Hydrostatic Pressure Testing	Section 7.0 Prior to Hydrostatic Testing
PTST 2.4 – Nitrogen Pressure Testing	Removed Section 8.0 Tube Trailer Requirements
PTST 2.6	Added, new section

PRESSURE TESTING

April 1, 2023

PTST 1 Requirements

1.0 Purpose

This document describes pressure testing requirements for mains, services, pipeline facilities, fabricated units/assemblies, and farm taps in accordance with 49 CFR 192 Subpart J.

2.0 Scope

This document addresses the following:

[3.0 Target Audience](#)[4.0 General](#)[5.0 Safety](#)[6.0 Roles and Responsibilities](#)[7.0 Test Medium](#)[8.0 Test Recording Methods](#)[9.0 Design MAOP](#)[10.0 Testing](#)[11.0 Plastic Pipe Testing](#)[12.0 Tie-In Joints](#)[13.0 Components and Fabricated Units/Assemblies](#)[14.0 Test Records](#)**3.0 Target Audience**

- Gas Engineering
- Gas Distribution Design Specialist
- Field Engineering Representatives
- Gas Field Personnel
- Gas Supervisors
- Gas Construction Services Personnel
- Gas Tech Engineering (GTE)
- Gas Tech Services (GTS) Supervisors
- Gas Tech Services (GTS) Personnel
- Gas Storage Engineers (GSE)
- Gas Storage Field Supervisors
- Gas Storage Field Personnel

4.0 General

- 4.1 All newly installed segments of a pipeline shall be pressure tested to identify any hazardous leaks and establish a design maximum allowable operating pressure (Design MAOP).
- 4.2 All new distribution, high pressure distribution, and transmission mains shall be pressure tested at 1.5 times the Design MAOP.
- 4.3 Testing segments of a pipeline to establish the Design MAOP shall be done after the pipe is in its final location, except for pre-tested short segments (i.e., typically a double random length approximately 40 to 45 feet or shorter) OR fabricated assemblies where post construction tie-in testing is not practical.

UNCONTROLLED IF PRINTED

- 4.4 Pre-tested pipe can be used for replacement, relocation, or repair where post installation testing is not practical. Pre-tested pipe shall be tested to meet or exceed the Design MAOP for the location it is being installed.
- 4.5 All required nondestructive testing (NDT) - such as x-ray inspections, including the necessary welding repairs identified by NDT - shall be completed before subjecting a segment of a pipeline to any leak or strength testing. If the final tie-in welds require NDT as specified in [WELD 1, Section 10.0](#) Nondestructive Testing, then NDT shall be completed prior to pressurizing the segment of a pipeline.
- 4.6 Bypasses that use steel or PE pipe attached to existing pipe with welded or fusion fittings shall be tested in the same manner as a new main. The pressure test should be documented on the as-built construction prints.
- 4.7 Bypasses connected to tapping and stopping equipment shall be made up of fittings, hose, or pre-tested pipe that are rated or tested for at least the maximum pressure encountered during the stopping operations. The pipe would need to be tested to at least 1.5 times the maximum pressure.
- 4.8 **Do not** apply test pressures against a closed valve. This does not apply to testing against a closed meter valve as long as test pressure does not exceed pressure rating of the valve. In-line valves should be tested in the open position unless otherwise specified in the project procedures.
- 4.9 **Do not** pressure test against a service tee, high volume tee, punch tee, valve tee, or 3-way tee that has been tapped on a pipe pressurized with natural gas unless natural gas is being used as test medium.

5.0 Safety

Precautions shall be taken to protect employees and the general public during any pressure test.

- 5.1 Avoid positioning anyone in the "line-of-fire" of any end caps, test caps, or fittings associated with the test.
 - 5.1.1 *Dresser and Normac compression style end caps or couplings* can only be used as a pressure test cap on pipe 1-inch nominal diameter or smaller and with an MAOP of 60 psig or less. Fittings shall be equipped with pullout restraint.
 - 5.1.2 *McElroy test caps* shall be equipped with the test cap lanyard which will minimize the travel of the test cap in the event the cap accidentally becomes dislodged. McElroy test cap has a maximum pressure rating of 165 psig. Refer to [POLY 4](#) McElroy TP 300 Series Test Cap.
- 5.2 Minimize the number of people (employees or general public) in the vicinity of the pressure test.
- 5.3 All valves, gauges, hoses, and fittings used for pressure testing shall have pressure ratings equal to or exceeding the maximum pressure that could be applied.

6.0 Roles and Responsibilities

- 6.1 *Gas Tech Engineering (GTE)* is responsible for reviewing testing requirements for:

- 6.1.1 All steel gas main/facility projects with Design MAOP greater than 60 psig which includes transmission or high-pressure distribution lines or facilities located outside of the Gas Storage Field or compressor plants.
- 6.1.2 All steel or PE service lines that are 2-inch nominal diameter and larger that have a Design MAOP greater than 60 psig.
- 6.1.3 All large meter sets with connected loads greater than 10,000 CFH and/or inlet pressure greater than 60 psig.
- 6.1.4 All regulator/flow control stations, odorizer stations and valve stations.
- 6.1.5 Service farm taps smaller than 2-inch nominal diameter are excluded since they are typically handled by Region Engineering.
- 6.1.6 Farm tap on a gas pressure system with a Design MAOP greater than 1,000 psig shall be designed or reviewed by GTE.
- 6.2 *Distribution Design Centers (DDC/PDC) or Region Engineering* are responsible for reviewing testing requirements for:
 - 6.2.1 All steel mains with Design MAOP 60 psig or less.
 - 6.2.2 All PE mains with Design MAOP of 125 psig or less.
 - 6.2.3 All PE and steel service lines with Design MAOP 125 psig or less.
 - 6.2.4 All PE and steel service lines 2-inch nominal diameter and larger with Design MAOP greater than 60 psig should also be reviewed by GTE.
 - 6.2.5 All high-pressure distribution farm tap services smaller than 2-inch nominal diameter.
 - 6.2.6 Emergency projects or maintenance projects on steel mains and services with Design MAOP 100 psig or less: Testing requirements may be specified by Region Engineering.
- 6.3 *Gas Storage Engineering (GSE)* is responsible for:
 - 6.3.1 Designing pressure-containing facilities, similar to a farm tap located within gas storage fields and compressor plants.
 - 6.3.2 Reviewing testing requirements on all gas facilities located within gas storage fields and compressor plants.

7.0 Test Medium

- 7.1 The test medium shall be air, nitrogen, water or combination of air and nitrogen, or natural gas. Natural gas should only be used for Uprates or Tie-Ins.
 - 7.1.1 Limitations on the use of natural gas, air or nitrogen as test medium during Strength Test are listed in [PTST 2.2, Section 5.0](#) Strength Test, Test Medium.
 - 7.1.2 The test medium must be compatible with the pipe material, be relatively free of sediment material, AND be nonflammable, except for natural gas.
 - 7.1.3 The test medium shall be water for:
 1. New or replaced transmission lines located in a High Consequence Area (HCA).
 2. Assessment for manufacturing and construction defects in an existing transmission line within an HCA.

3. New or replaced transmission line installed within 300 feet of a building intended for human occupancy in a Class 1 or Class 2 location unless the building is vacated while the test pressure exceeds 50% SMYS.
- 7.1.4 Water is the preferred test medium for all transmission lines. Other mediums may be used with engineering approval. Exceptions include, but are not limited to, locations where: there is not adequate accessibility, temperatures may cause test medium to freeze, de-watering processes are not feasible.

The transmission testing requirements do not apply to control lines, service lines, or gas regulator stations not considered transmission.

- 7.2 For hydrostatic testing requirements, including spike hydrostatic pressure test, see [PTST 2.3](#).
- 7.3 For nitrogen testing requirements, see [PTST 2.4](#).

8.0 Test Recording Methods

- 8.1 The following methods can be used to record leak, strength, or combination leak/strength test which establish or verify the design MAOP:
 - 8.1.1 *Gauges*: The following gauges can be used when performing a leak, strength, or combination leak/strength test on lines that are being tested at less than 20% SMYS OR for fabricated unit and short sections of pipe.
 1. Process Gauges: See [Section 8.2](#) below.
 2. Test Gauges and Calibrating Gauges: See [METR 2.6 Section 5.0](#), Gauge Definitions.
 - 8.1.2 *Pressure Recording Device*: Refer to [PTST 1.1 Appendix D](#) for recording devices required for hydrostatic testing designated transmission or classified transmission facilities.
 1. Mechanical pressure chart recorder.
 2. Electronic pressure recorder.
 3. Calibrated dead weight tester system: The pressure reading shall be manually recorded every half-hour and entered on a log that will become part of the final as-built documentation.

Gauges or recorders with digital displays should be read and recorded in whole units. Round down readings to the nearest whole psig unit.

- 8.2 *Process gauges*: Use process gauges rated ASME Grade 2A with minimum accuracy of $\pm 0.5\%$ full scale to perform a leak and/or strength test which establishes or verifies the Design MAOP.
 - 8.2.1 The gauge shall be in good condition and the needle should read zero before subjecting the gauge to pressure.

8.2.2 See Table 1 below for stock coded process gauges.

Table 1: Process Gauges

Grade 2A, ± 0.5% Full Scale Accuracy, Black Plastic Case, 4-1/2" Face	
Stock Code	Range (PSIG)
49 22 284	0 - 30
49 22 285	0 - 60
49 22 286	0 - 100
49 22 287	0 - 200
49 22 288	0 - 400
49 22 289	0 - 600
49 22 290	0 - 1000
49 22 291	0 - 1500
49 22 292	0 - 2000
49 22 293	0 - 3000

8.2.3 Process gauges used to perform a leak and/or strength test should be verified for accuracy (±0.5%) at mid-scale annually not to exceed 15 months.

1. New process gauges placed into service do not need to be verified for accuracy until the following year.
2. Use a test gauge, calibrating gauge or calibrated dead weight tester to verify accuracy of a process gauge.

8.2.4 Process gauges should have a unique identifier assigned. Document verification date.

8.3 Pressure and temperature chart recorders or electronic recording devices shall be calibrated annually not to exceed 15 months.

8.4 Calibration of Ameren-owned pressure and temperature chart recorders and electronic recording devices shall be maintained in Maximo.

8.5 For projects using contractor-owned pressure and temperature chart recorders, recording devices, or a calibrated dead weight tester, the contractor shall provide a copy of the calibration documentation for the recorder. See [PTST 2.1 Section 7.0](#) Leak Test Records and [PTST 2.2 Section 7.0](#) Strength Test Records.

9.0 Design MAOP

9.1 The Design MAOP is the highest pressure that a new or replaced pipeline segment could ever be expected to be operated.

9.2 Any new systems or additions to existing systems shall be designed to the appropriate Design MAOP.

9.2.1 Region Gas Engineer, GTE or GSE will designate the specific Design MAOP for systems or segments to be operated over 60 psig.

9.2.2 The Design MAOPs of an existing system are shown in the Ameren Illinois electronic mapping system.

9.3 Maximum test pressure on steel pipe with Design MAOP of 100 psig or greater should not exceed that designated by GTE or GSE.

- 9.4 If the specified maximum test pressure is exceeded immediately reduce to below maximum, and notify Gas Supervisor or Contractor Services Supervisor. Gas Engineering, GTE or GSE will evaluate and determine what action needs to be taken, if any.

10.0 Testing

- 10.1 See [PTST 2.1](#) for required leak testing information.
- 10.2 See [PTST 2.2](#) for required strength testing information.
- 10.3 Refer to [PTST 1.1](#) Test Pressure and Duration Requirement Tables for test pressure and test duration requirements for standard construction activities associated with mains, services, fabricated units, and farm taps.
- 10.3.1 [Table A - Service Lines, Less Than 2" Diameter, Plastic or Steel](#)
- 10.3.2 [Table B - Plastic Main, All PE Pipe Sizes Thru 12" With Design MAOP 125 psig or Less](#)
- 10.3.3 [Table C - Steel Main, All Steel Pipe Sizes Thru 18" With Design MAOP Less Than 100 psig](#)
- 10.3.4 [Table D - Steel Main, All Steel Pipe Sizes Thru 30" With Design MAOP 100 psig or Greater](#)
- 10.3.5 [Table E - Fabricated Unit/Assembly or Short Section of Pipe](#)
- 10.3.6 [Table F - Farm Tap, Single Cut, 60 To 450 PSIG Inlet Pressure](#)
- 10.3.7 [Table G - Farm Tap, Double Cut, 451 To 1000 PSIG Inlet Pressure](#)
- 10.4 Refer to [Section 13.0](#) below for testing requirements for components (other than pipe) being replaced or added to a pipeline.
- 10.5 Main and service lines should be tested separately. This helps to locate leaks resulting from a pressure test. For short main extension, repair, or emergency projects, the Gas Supervisor or Project Engineer may approve testing main and services together. Refer to Subsection 10.6 for PE4710 testing and meter valve limitations.
- 10.5.1 Service lines smaller than 2 inch in diameter: The minimum required test duration for the combination main and service is determined by the required test duration of the main as shown in [PTST 2.1 Section 5.0](#) Leak Test Duration. There is no need to add time for the service lines.
- 10.5.2 Service lines 2 inch and larger shall be tested as main with the minimum duration determined in accordance with [PTST 2.1 Section 5.0](#) or if applicable [PTST 2.1 Section 5.4](#), leak test duration when testing main of various sized pipe.
- 10.5.3 Record service line pressure test on the Service Card within ClickMobile with the actual test pressure and actual test duration reported for each services.
- 10.6 PE4710 mains and service lines with Design MAOP of 125 psig shall be tested separately, due to meter valve limitations, unless approved by the gas engineer.
- 10.6.1 Meter valves rated for 175 psig shall not be exposed to a pressure of 200 psig or higher for more than 2 hours. Exceeding 200 psig for longer periods may cause damage to the valve.
1. The minimum test pressure for a MAOP of 125 psig is 188.0 psig
 2. Testing the PE4710 service line separately should limit the test duration to less than 2 hours and allow the pressure on the service line to be relieved or lowered to below 200 psig following completion of the pressure test.

3. The meter valve pressure limitations stated above applies to all service lines, PE2708, PE4710 and steel.

10.7 Short segments of piping should be tested as follows:

- 10.7.1 *Short segments of piping and with nominal diameter of 2 inches or larger* should be tested in accordance with [PTST 1.1 Table E](#), Fabricated Unit/Assembly or Short Section of Pipe.
- 10.7.2 *Short segments of piping, smaller than 2 inch nominal diameter, and fittings/assemblies typically known as gauge taps, pressure taps, odorant taps, purge points, and/or control line taps* should be tested in accordance with [PTST 1.1 Table A](#), Service Lines - Less Than 2" Diameter; Plastic or Steel.

11.0 Plastic Pipe Testing

- 11.1 Before testing, fusion joints shall be allowed to cool for the manufacturer's specified cool time.
 - 11.1.1 **Do not** test PE pipe if the temperature of the material is greater than 140°F.
 - 11.1.2 **Do not** make fusion joints on PE pipe that is being pressure tested.
 - 11.1.3 **Do not** perform hydrostatic pressure testing on PE pipe.
- 11.2 If McElroy Test Cap is being utilized, follow the manufacturer's operating instructions. Refer to [POLY 4](#) McElroy TP 300 Series Test Cap.
 - 11.2.1 McElroy Test Cap is limited to a maximum test pressure of 165 psig.
 - 11.2.2 McElroy Test Cap shall not be used when testing HDPE for a MAOP of 125 psig.

12.0 Tie-In Joints

- 12.1 Tie-in joints are the final connections made when connecting a new segment of pipe, a component, or an assembly, that has been tested to the appropriate Design MAOP, to or into an existing pipeline or facility where post-installation testing is impractical.
- 12.2 Tie-in joints that are not pressure tested must be checked for leaks at current operating pressure with leak detection fluid or leak detection instrument (if test medium is natural gas).
- 12.3 Tie-in joints on steel transmission pipelines shall be tested in accordance with the NDT provisions contained in [WELD 1 Section 10.0](#) Nondestructive Testing, before performing a leak test at current operating pressure.
- 12.4 Document and record the leak test results.

13.0 Components and Fabricated Unit/Assemblies

- 13.1 If only a single component, other than pipe, is being replaced or added to the pipeline, then the connection to the pipe shall be checked for leaks.

An exception exists for pressure rated repair fittings. See the [REPR](#) section.

- 13.1.1 *Component attached to pipeline with Design MAOP less than 100 psig*: Minimum test pressure required to check for leaks should be 90 psig.

- 13.1.2 *Component attached to pipeline with Design MAOP 100 psig or greater:* Minimum test pressure required to check for leaks should be a minimum of 100 psig with a maximum not to exceed the pressure specified by Engineering.
 - 13.1.3 Components shall be tested for leaks using leak detection fluids, leak detection instrument or via gauge test.
 1. Gauge test shall be held for minimum of 10 minutes.
 2. Leak detection fluids or leak detection instruments have no minimum test duration.
 - 13.1.4 Tapping and stopping components (Stopper, Save-A-Valve, Thread-O-Ring) shall be tested for leaks PRIOR to tapping.
 - 13.1.5 *A component (e.g., cap, valve, elbow) installed within an existing pipeline:* Connections shall be tested for leaks at operating pressure of the pipeline using leak detection fluids or leak detection instruments.
 - 13.1.6 Component with a nominal diameter of less than 2 inches shall be, at a minimum, tested for leaks at operating pressure of the pipeline using leak detection fluids or leak detection instruments. Engineering may specify gauge test prior to tapping on critical applications.
- 13.2 The component does not have to be strength tested to substantiate the MAOP after installation IF:
- 13.2.1 It carries a pressure rating established through applicable ASME/ANSI/ASTM specifications that meets or exceeds the design MAOP of the pipe to which it is being added or attached. Examples of such components include:
 1. Flange
 2. Steel valve
 3. PE valve
 4. Line stopper fitting
 5. Weld-End Insulator
 - 13.2.2 It is manufactured under a quality control system that ensures each item manufactured is at least equal in strength to the prototype AND the prototype was tested to at least the design MAOP of the pipe to which it is being added or attached. Examples of such components include:
 1. Weld fitting (i.e., in-line tee, elbow, cap, thread-o-let, service tee with mechanical connection, save-a-valve nipple)
 2. Threaded fitting (i.e., tee, elbow, cap, coupling, union, nipple, reducer)
 3. TDW PE Branch Saddle Valve
 - 13.2.3 The manufacturer certifies that the component was tested to at least the design MAOP of the pipe to which it is being added or attached. Examples of such components include:
 1. Rotary meter loops
 2. Meter headers
 3. Ultrasonic Meter spool

13.3 Prefabricated Unit/Assemblies

13.3.1 Once another item (e.g., pipe, fitting or another component) is attached to the component, it becomes an "assembly" which requires testing to establish or verify the assembly's Design MAOP prior to installation. Examples of prefabricated assemblies include:

1. Metering Station
2. Regulating Station
3. Valve station
4. Pig launchers and receivers built from pipe and standard fittings
5. Prefabricated sections of pipeline sections consisting of one or more joints of pipe, valve or fittings.

13.3.2 Prefabricated assemblies are tested in accordance with:

1. *Assemblies with nominal diameter smaller than 2 inches*: Test in accordance with [PTST 1.1 Table A](#).

13.3.3 *Assemblies with nominal diameter of 2 inches or larger*: Test in accordance with [PTST 1.1 Table E](#).

13.3.4 Prefabricated assemblies classified as a transmission facility are to be hydrostatic pressure tested. Refer to [Paragraph 7.1.4](#) for an exception

13.3.5 Short assemblies of all NPT threaded components listed above may be leak tested at current operating pressure. These assemblies may include:

1. Meter tie-ins.
2. Meter rebuilds.
3. Relief stacks.

This does not apply to any welded connections or NPT connections made from cut and threaded pipe.

If the required test pressure for a bottom-out line stopper assembly exceeds the collapse pressure of the carrier pipe, see [TAPS 1 Appendix C](#) for fabricating and testing details of the assembly.

13.4 All mechanically connected instrument, control, and sampling lines shall be rated for the maximum service pressure of the pipe or equipment to which it is attached and shall be checked for leaks at the current operating pressure.

13.5 ASME pressure vessels testing and inspection requirements are in [PTST 2.6](#) ASME Pressure Vessels.

14.0 Test Records

14.1 Requirements

14.1.1 All test records shall be retained for the useful life of the facility. This includes:

1. Leak test for service lines.

2. Leak tests for distribution lines with MAOP less than 100 psig.
3. Leak and strength tests for transmission lines or high-pressure distribution lines with MAOP of 100 psig and less than 30% SMYS.
4. Strength tests on transmission lines with MAOP of 30% SMYS or greater.
5. A separate leak test is not required when hydrostatic pressure testing lines or facilities
6. Hydrostatic tests on transmission lines.
7. Required spike tests on transmission lines.

14.1.2 Each leak test and/or strength test shall be documented on the appropriate Ameren Illinois (AIC) forms. [Click here to access the SharePoint site](#) where the most current test forms are maintained:

1. *The Leak Test Form/Stamp (LTF)* ([PTST 3 Form 01](#)) is included on construction plans generated by the Distribution Design Centers, or Region Gas Engineers. This stamp is normally used on projects with MAOP of 60 psig or less. However, this form/stamp can be used for HDPE pipe installations which have a MAOP of 100 psig.
2. *The Leak & Strength Test Form (LSTF)* ([PTST 3 Form 02](#)) is included with the projects generated by Gas Tech Engineering, Gas Storage Engineering or Region Gas Engineer. This form is normally used on projects with MAOP of 60 psig or higher but is acceptable for any project.
3. *The Hydrotest Strength Test Form* ([PTST 3 Form 03](#)) is included with projects generated by Gas Tech Engineering or Gas Storage Engineer when hydrostatic pressure testing is required.

14.1.3 Changes may be made to the test form between O&M Updates, so the test form/stamps on the plans may differ from the ones in [PTST 3](#). Whichever version is on the plans continues to be valid and acceptable.

14.1.4 For pre-tested pipe, either transfer the test record to the appropriate test stamp/test record or place a copy of the original test record in the as-built job file.

14.2 Leak, Strength, and Hydrostatic Test Records

14.2.1 Each leak test performed on a main or fabricated unit shall be documented on the appropriate AIC forms. See [PTST 3](#) for LTF (Leak Test Form) or LSTF (Leak Strength Test Form) or Hydrotest Strength Test Form.

1. Leak tests performed on service lines are documented on the Service Card module within ClickMobile.
2. Leak testing on meter set piping shall be recorded on the meter set plans test stamp.

14.2.2 Each strength test shall be documented on the appropriate AIC forms. See [PTST 3](#) for LSTF (Leak Strength Test Form) or Hydrotest Strength Test Form.

14.2.3 Test records shall include the following information, at a minimum:

1. Description of facilities being tested, including:
 - 1 a. Pipe size and type.
 - 1 b. Length of test segment.

- 1 c. Beginning and end location of the test segment (e.g., measurements, stationing, GPS coordinates, facility identification, or other methods that will describe the location).
2. Test medium used.
3. Actual leak test pressure or strength test pressure (as applicable).
4. Actual leak test duration or strength test pressure (as applicable).
5. Actual spike test pressure (if applicable).
6. Actual spike test duration (if applicable).
7. Documentation of beginning and end of test period(s). If recording chart is recording both a leak and a strength test that have different test pressures and duration, the beginning and end of each test should be indicated.
8. Date of the test.
9. Employee responsible for overseeing the test.
10. Contractor's name and/or name of test company (if applicable).
11. Recording device type, ID or serial number of recording device, and calibration date.

When hydrostatic pressure test is performed, locations of the pressure recording devices shall be recorded and maintained in the final as constructed job packet.

12. Owner of the pressure recording device.
 13. Any leaks and failures shall be noted and their disposition shall be recorded in the Comments section on the test stamp. Once the leak or cause of failure is repaired or corrected, initiate a new test.
 14. Once the pressure has initially stabilized, document any pressure fluctuation due to outside forces on the recording chart.
 - 14 a. Pressure fluctuation due to temperature change that occurs during test duration should be documented with calculation verifying the fluctuation is not due to a leak and approved by Integrity Management, GTE or GSE prior to acceptance of the test.
- 14.2.4 Test records shall be retained in the final as constructed job packet.
- 14.2.5 Test records shall be retained for useful life of the facility.

End of Instructions.

Operator Qualification (OQ) Required?

YES

0561: Pressure Test - Nonliquid Medium - MAOP Less than 100 Psi

0571: Pressure Test - Nonliquid Medium - MAOP Greater than or Equal to 100 Psi

UNCONTROLLED IF PRINTED

0581: Pressure Test - Liquid Medium

0591: Pressure Test - Leak Test at Operating Pressure

Appendices

NONE.

Attachments

NONE.

Compliance Requirements

49 CFR Part 192 - Amendments published October 1, 2019 in 84 FR 52245:

§192.506 Transmission lines: Spike hydrostatic pressure test.

§192.619 Maximum allowable operating pressure: Steel or plastic pipelines.

§192.624 Maximum allowable operating pressure reconfirmation: Onshore steel transmission pipelines.

§192.710 Transmission lines: Assessments outside of high consequence areas.

§192.917 How does an operator identify potential threats to pipeline integrity and use the threat identification in its integrity program?

49 CFR 192 Subpart J - Test Requirements

§192.501 Scope.

§192.503 General requirements.

§192.505 Strength test requirements for steel pipeline to operate a hoop stress of 30 percent or more of SMYS.

§192.506 Transmission lines: Spike hydrostatic pressure test.

§192.507 Test requirements for pipelines to operate at a hoop stress less than 30 percent of SMYS and at or above 100 p.s.i. (689 kPa) gage.

§192.509 Test requirements for pipelines to operate below 100 p.s.i (689 kPa) gage.

§192.511 Test requirements for service lines.

§192.513 Test requirements for plastic pipelines.

§192.515 Environmental protection and safety requirements.

§192.517 Records.

Reference Documents

[METR 2.6 Metering: Pressure Gauges](#)

[PTST 1.1 Pressure Testing: Test Pressure and Duration Tables](#)

[PTST 2.1 Pressure Testing: Leak Test](#)

[PTST 2.2 Pressure Testing: Strength Test](#)

[PTST 2.3 Pressure Testing: Hydrostatic Pressure Testing](#)

[PTST 2.4 Pressure Testing: Nitrogen Pressure Testing](#)

[PTST 3 Pressure Testing: Forms and Reference Materials](#)

UNCONTROLLED IF PRINTED

[TAPS 1 Tapping and Stopping: Requirements](#)

[WELD 1 Welding: Requirements](#)

Document Rescission

PTST 1 Pressure Testing: Requirements, October 1, 2022

Revision Notes

Location of Changes	Summary of Changes
Paragraph 8.1.1 – Test Recording Methods – Gauges	Correction – 20% SMYS replaced 30% SMYS. Consistent with testing tables in PTST 1.1. Pressure recording devices are required when testing transmission classified or designated facilities.
Paragraph 8.1.2 – Test Recording Methods	<p>Revised - Pressure Recording Device: Refer to <u>PTST 1.1 Appendix D</u> for recording devices required for hydrostatic testing designated transmission or classified transmission facilities.</p> <ol style="list-style-type: none"> 1. Mechanical pressure chart recorder. 2. Electronic pressure recorder 3. Calibrated dead weight tester system.
Paragraph 8.1.2 – Dead weight tester system - Item 3	Grammatical – The pressure reading shall be manually recorded every half-hour and entered on a log that will become part of the final as-built documentation.
Paragraph 8.1 – Test Recording Methods	Original Item 4 under Paragraph 8.1.2. was placed in a NOTE that applies to Paragraph 8.1.1 and 8.1.2: Gauges or recorders with digital displays should be read and recorded in whole units. Round down readings to the nearest whole psig unit.

PRESSURE TESTING

April 1, 2023

PTST 1.1 Test Pressure and Duration Requirement Tables

1.0 Purpose

The tables in this section provide the minimum (and in some cases, the maximum) test pressure and minimum test duration for leak test and when required strength test.

Table designation is based on standard construction activities for PE2708 (MDPE), PE4710 (HDPE) and steel pipe construction and installation along with the Design MAOP.

Specific testing requirements are contained in [PTST 1](#) Requirements, [PTST 2.1](#) Leak Test, and [PTST 2.2](#) Strength Test.

2.0 Tables

- 2.1 [Appendix A](#) - Service Lines, Less Than 2" Diameter; Plastic or Steel
- 2.2 [Appendix B](#) - Plastic Main, All PE Pipe Sizes thru 12" with Design MAOP 125 psig or Less
- 2.3 [Appendix C](#) - Steel Main, All Steel Pipe Sizes thru 18" with Design MAOP Less Than 100 psig
- 2.4 [Appendix D](#) - Steel Main, All Steel Pipe Sizes thru 30" with Design MAOP 100 psig or Greater
- 2.5 [Appendix E](#) - Fabricated Unit/Assembly or Short Section of Pipe
- 2.6 [Appendix F](#) - Farm Tap, Single Cut, 60 to 450 psig Inlet Pressure
- 2.7 [Appendix G](#) - Farm Tap, Double Cut, 451 to 1,000 psig Inlet Pressure

End of Instructions.

Reference Documents

- [PTST 1 Pressure Testing: Requirements](#)
- [PTST 2.1 Pressure Testing: Leak Test](#)
- [PTST 2.2 Pressure Testing: Strength Test](#)
- [STLP 2.2 Steel Pipe: Design Pressure](#)
- [TAPS 1 Tapping and Stopping: Requirements](#)

Document Rescission

PTST 1.1 Test Pressure and Duration Tables – October 1, 2022

Revision Notes

Location of Changes	Summary of Changes
Appendix D - Steel Mains, All Sizes, MAOP of 100 PSIG or Greater – Original D-5	Removed, Information covered in Notes 3 and 4 below Table D

UNCONTROLLED IF PRINTED

Appendix D - D-5	New- Facilities that are designated as transmission or with a Design MAOP that result in stress of 20% SMYS or higher, a mechanical pressure chart recorder is required in addition to an electronic pressure recorder or dead weight tester system when recording hydrostatic pressure tests.
Appendix D –Table D	Added "Excluding designated transmission (4)" under the ≥100 psig AND <20% SMYS in the Design MAOP column.
Appendix D –Table D – Bot- tom Line of Table	Revised - All pipeline facilities that are designated as transmission or with a Design MAOP at or above 20% SMYS are to be hydrostatically pressure tested whether tested in place or re-tested. Refer to PTST 1 Paragraph 7.1.4 for exceptions.
Appendix D – Note (4)	Replaced original D-5 - For designated transmission pipe with a Design MAOP less than 20% SMYS, the pipe shall meet the requirements shown in Table D for 20% SMYS to less than 30% SMYS.
Appendix F – Farm Tap, Sin- gle Cut	Reformatted bottom section of table. From Main to Out- let of Farm Tap line relates to the Note: Outlet Service Lines are a separate issue.
Appendix G – Farm Tap, Double Cut	Reformatted bottom section of table. From Main to Out- let of Farm Tap line relates to the Note: Outlet Service Lines are a separate issue.

Appendix A - Service Lines, Less than 2" Diameter, Plastic or Steel

A-1. Table A provides test pressure and test duration requirements for standard construction activity associated with plastic and steel service lines, short segments of pipe sizes smaller than 2 inches in nominal diameter and gauge tap type fittings/assemblies.

Table A: Service Lines, Less Than 2" Diameter; Plastic or Steel

Material	Design MAOP	Test	Test Pressure		Test Duration
			Minimum	Maximum	
PLASTIC MDPE & HDPE	60 psig	Leak Test Note (1)	90 psig	180 psig	Minimum 10 Min.
PLASTIC HDPE	125 psig	Leak Test Note (1)	188 psig	260 psig Note (3)	Minimum 10 Min.
STEEL	≤ 100 psig	Leak Test Note (1)	90 psig OR 1.5 x Design MAOP Note (2)	260 psig Note (3)	Minimum 10 Min.
	> 100 psig	Leak Test Note (1)	1.5 x Design MAOP Note (4)		Minimum 10 Min.
PLASTIC AND STEEL	If the service has both steel and plastic pipe, then test to the Plastic Pipe Requirements.				

UNCONTROLLED IF PRINTED

Gauge or Recording Device can be used to measure test pressures.

Note (1): The single Leak Test satisfies requirements in that it will ensure there are no hazardous leaks and qualifies the Design MAOP of the service line.

Note (2): If Design MAOP is greater than 60 psig, the minimum test pressure is 1.5 times Design MAOP.

Note (3): Maximum pressure shall be lowered to below 200 psig within 2 hours to avoid damage to meter valve.

Note (4): Steel services only: If the service line is tested at a pressure that will result in hoop stress of 20% SMYS or more, then it shall be tested in accordance with [Table D](#), Steel Main with Design MAOP ≥ 100 psig.

Stock Code	Pipe Size (inches)	Wall Thickness (inches)	20% SMYS (psig)
32 23 302	¾"	0.113"	1,507
32 23 303	¾"	0.154"	2,053
32 23 312	1-1/4"	0.140"	1,181

Appendix B - Plastic Main, All PE Pipe Sizes Thru 12" With Design MAOP 125 psig or Less

B-1. Table B provides test pressure and test duration requirements for standard construction activities associated with plastic main pipe sizes through 12 inch, which includes plastic service lines pipe sizes with 2 inch and larger nominal diameter:

Table B: Plastic Main, All PE Pipe Sizes Thru 12" With Design MAOP <_ 125 psig

Material	Design MAOP	Test	Test Pressure		Test Duration
			Minimum	Maximum	
PLASTIC MDPE & HDPE	60 psig	Leak Test Note (1)	90 psig	180 psig (150 psig for 8" and larger MDPE)	See B-2 below
PLASTIC HDPE	125 psig	Leak Test Note (1)	188 psig	260 psig	See B-2 below Note (2)

Gauge or Recording Device can be used to measure test pressures.

Note (1): The single Leak Test satisfies test requirements in that it will ensure there are no hazardous leaks and qualifies the Design MAOP of the pipe.

Note (2): 2 inch and larger service lines with 175 psig rated meter valves shall not be exposed to pressures greater than 200 psig for more than 2 hours. Refer [PTST 1 Paragraph 10.6.1](#) for meter valve limitations.

B-2. Duration information from [PTST 2.1 Section 6.0](#) Leak Test Duration, is summarized below:

B-2.1 For mains and 2 inch and larger service lines, leak test duration shall be 5 minutes per inch of nominal pipe diameter per 100 feet of pipe length with minimum test duration as listed below for the specific pipe diameter.

Pipe Size	≤ 2"	4"	6"	8"	10"	12"
Time per 100 ft. of Pipe	10 Min.	20 Min.	30 Min.	40 Min.	50 Min.	60 Min.
Minimum Duration	10 Min.	20 Min.	30 Min.	40 Min.	50 Min.	60 Min.

UNCONTROLLED IF PRINTED

- B-2.2 To determine the required test duration, round up the actual pipe footage to be tested to the next 100-foot increment. (i.e., 25 feet would round up to 100 feet).
- B-2.3 Calculate the required leak test duration for the pipe size and length to be tested. The maximum required leak test duration is 8 hours regardless of the additional footage of pipe to be tested.

Appendix C - Steel Main, All Steel Pipe Sizes Thru 18" With Design MAOP Less Than 100 psig

C-1. Table C provides the test pressure and test duration requirements for standard construction activity associated with steel main pipe sizes through 18 inch nominal diameter and steel service lines 2 inch and larger nominal diameter with Design MAOP of less than 100 psig:

Table C: Steel Main, All Steel Pipe Sizes Thru 18" (Design MAOP < 100 psig)

Material	Design MAOP	Test	Test Pressure		Test Duration
			Minimum	Maximum	
STEEL	≤ 60 psig	Leak Test Note (1)	90 psig	180 psig	See C-2 below
	> 60 psig AND < 100 psig	Leak Test Note (1)	150 psig OR 1.5 x Design MAOP Note (2)	200 psig	See C-2 below
<i>Gauge or Recording Device can be used to measure test pressures.</i>					

Note (1): The single Leak Test satisfies requirements in that it will ensure there are no hazardous leaks and qualifies the Design MAOP of the service line.

Note (2): If Design MAOP is greater than 60 psig AND less than 100 psig, the minimum test pressure is 1.5 times Design MAOP.

C-2. Duration information from [PTST 2.1 Section 6.0](#) Leak Test Duration is summarized below:

C-2.1 For mains and 2 inch and larger service lines, the leak test duration shall be 5 minutes per inch of nominal pipe diameter per 100 feet of pipe length with minimum test duration as listed below for the specific pipe diameter.

Pipe Size	≤ 2"	4"	6"	8"	10"	12"	14"	16"	18"
Time per 100 ft. of Pipe	10 Min.	20 Min.	30 Min.	40 Min.	50 Min.	60 Min.	70 Min.	80 Min.	90 Min.
Minimum Duration	10 Min.	20 Min.	30 Min.	40 Min.	50 Min.	60 Min.	70 Min.	80 Min.	90 Min.

C-2.2 To determine the required test duration, round up the actual pipe footage to be tested to the next 100-foot increment. (e.g., 25 feet would round up to 100 feet).

C-2.3 Calculate the required leak test duration for the pipe size and length to be tested. The maximum required leak test duration is 8 hours regardless of the additional footage of pipe to be tested.

Appendix D - Steel Main, All Steel Pipe Sizes Thru 30" With Design MAOP 100 psig or Greater

D-1. Table D provides the test pressure and test duration requirements for general construction activity associated with steel mains pipe sizes through 30 inch and steel service lines 2 inch and larger with Design MAOP greater than or equal to 100 psig.

D-2. GTE or GSE is responsible for reviewing testing requirements for all gas main/facility projects with Design MAOP greater than 100 psig which includes transmission, high

pressure distribution lines and facilities or transmission lines and facilities within Gas Storage Fields/Compressor Plants.

- D-3. GTE or GSE should be notified when there is any testing to be performed on these pipes. Region Engineering can specify testing requirements for replacement or relocation projects due to line repair.
- D-4. GTE or GSE will provide hydrostatic testing plan for pipelines classified as transmission. The test pressure and duration shall at least meet the minimum shown under the appropriate category in Table D.
- D-5. Facilities that are **designated as transmission or with a Design MAOP that results in stress of 20% SMYS or higher, a mechanical pressure chart recorder is required in addition to an electronic pressure recorder or dead weight tester system when recording hydrostatic pressure tests.**

Table D: Steel Main, All Steel Pipe Sizes Thru 30" (Design MAOP ≥ 100 psig)

Material	Design MAOP	Test	Test Pressure		Test Duration	Test Pressure Measurement	
			Minimum	Maximum			
STEEL	≥ 100 psig AND < 20% SMYS Excluding designated transmission (4)	Leak Test	100 psig	20% SMYS	Minimum 1 hour	Gauge or Recording Device may be used.	
		Strength Test	1.5 x Design MAOP	Note (2)	Minimum 1 hour		
	≥20% SMYS and < 30% SMYS	Leak Test Note (3)	100 psig	20% SMYS	Minimum 1 hour	Recording Device is Required.	
		Strength Test	1.5 x Design MAOP	Note (2)	Minimum 1 hour		
	≥ 30% SMYS	Leak Test	100 psig	20% SMYS	Minimum 1 hour	Recording Device is Required.	
	≥ 30% SMYS Note (1)	Strength Test	1.5 x Design MAOP	Note (2)	Minimum 8 hours		
	All pipeline facilities that are designated as transmission or with Design MAOP at or above 20% SMYS are to be hydrostatically pressure tested, whether tested in place or re-tested. Refer to PTST 1 Paragraph 7.1.4 for exceptions.						

Note (1): Refer to [STLP 2.2 Appendix A](#) Design Pressure - Steel Pipe Stock Code Table to determine pressure that would result in stressing pipe to 30% SMYS. If the pipe being tested is not shown in this table, contact GTE, GSE, or local Gas Engineer.

Note (2): Maximum test pressure on steel pipe with Design MAOP of 100 psig or greater should not exceed that designated by GTE or GSE.

Note (3): Leak test is required when non-hydrostatic testing is performed.

Note (4): For designated transmission pipe with Design MAOP less than 20% SMYS, the pipe shall meet the requirements shown in Table D for 20% SMYS to less than 30% SMYS.

Appendix E - Fabricated Unit/Assembly or Short Sections of Pipe

UNCONTROLLED IF PRINTED

- E-1. Tables [E\(1\)](#) and [E\(2\)](#) provide test pressure and test duration requirements for fabricated units/assemblies (except farm taps) and for short sections of pipe (typically 40 to 45 feet or less) where post installation testing is impractical. Once pipe or fitting is attached to a component (see [PTST 1 Section 13.0](#) Components) it becomes a unit/assembly which requires testing in accordance with the applicable table below.
- E-2. A single joint of steel pipe with a MAOP of 100 psig or greater, where the end caps will be removed prior to installation, requires only a strength test. If the single joint of pipe contains joints within the segment, both leak and strength is required.
- E-3. Fabricated Unit/Assembly refers to sections of pipe and various fittings which are assembled together, either in a shop environment or in the field, and then attached to the pipe or connected to the system. Where post installation testing is impractical, the fabricate unit/assembly shall be pre-tested to at least meet the Design MAOP of the system to which it is being attached. Typical examples of fabricated unit/assembly include: regulator stations, valve stations, commercial/industrial regulating/metering sets, odorizer stations, pig launcher/receivers, pipeline offset sections, valve connections, etc.
- E-4. Transmission fabricated units and short sections of pipe, where post installation testing is impractical, a pre-installation hydrostatic pressure test shall be conducted in accordance with [Table E\(2\)](#). Only a strength test is required when hydrostatic pressure test is performed.
- E-5. If test pressure for bottom-out line stopper assembly exceeds the collapse pressure of the pipe, refer to [TAPS 1 Appendix C](#).
- E-6. GTE or GSE will determine when transmission facilities are to be hydrostatically pressure tested and will provide required test durations and pressures in the testing plan which may deviate from those shown in [Table E\(2\)](#).
- E-7. Short segments of pipe sizes smaller than 2 inches in nominal diameter and gauge tap type fittings/assemblies are to be tested in accordance with [Appendix A](#).
- E-8. When installing a pre-tested fabricated unit at its final installation location, check for damage including at inlets, outlets and lifting locations. Identify defects such as dents, gouges, bending, corrosion, and cracking. If threats are found, conduct non-destructive test, re-pressure test, or repair.
- E-9. Table E(1), Fabricated Unit/Assembly or Short Section of Pipe (Design MAOP Less than 100 psig, or 125 psig or less for PE pipe):

Table E(1): Fabricated Unit/Assembly or Short Section of Pipe (Design MAOP Less than 100 psig, or 125 psig or less for PE pipe)

Material	Design MAOP	Test	Test Pressure		Test Duration
			Minimum	Maximum	
PLASTIC MDPE & HDPE	60 psig	Leak Test Note (1)	90 psig	180 psig (150 psig for 8" MDPE)	See E-9.1 below
PLASTIC HDPE	125 psig	Leak Test Note (1)	188 psig	260 psig	See E-9.1 below
STEEL	< 100 psig	Leak Test Note (1)	90 psig OR 1.5 x Design MAOP Note (2)	200 psig	See E-9.1 below
Gauge or Recording Device can be used to measure test pressures.					

Note (1): The single Leak Test satisfies requirements in that it will ensure there are no hazardous leaks and qualifies the Design MAOP of the unit, assembly or pipe.

Note (2): If Design MAOP is greater than 60 psig but less than 100 psig, the minimum test pressure is 1.5 times Design MAOP.

E-9.1 *Minimum Leak Test Duration Table*: For fabricated unit/assembly containing multiple sizes of pipe and/or fittings, use the minimum duration for the largest size of pipe.

Pipe Size	≤ 2"	4"	6"	8"	10"	12"	14"	16"	18"
Minimum Duration	10 Min.	20 Min.	30 Min.	40 Min.	50 Min.	60 Min.	70 Min.	80 Min.	90 Min.

E-10. Table E(2), Fabricated Unit/Assembly, or Short Section of Steel Pipe (Design MAOP of 100 psig or Greater):

Table E(2): Fabricated Unit/Assembly or Short Section of Steel Pipe

Material	Design MAOP	Test	Test Pressure		Test Duration
			Minimum	Maximum	
STEEL	≥ 100 psig	Leak Test	100 psig	20% SMYS	Minimum 1 hour
	AND < 20% SMYS	Strength Test	1.5 x Design MAOP	Note (3)	Minimum 1 hour
	≥ 20% SMYS	Leak Test Note (5)	100 psig	20% SMYS	Minimum 1 hour
	AND < 30% SMYS	Strength Test	1.5 x Design MAOP	Note (3)	Minimum 1 hour
	≥ 30% SMYS Note (4)	Strength Test	1.5 x Design MAOP	Note (3)	Minimum 4 hours
	All pipeline facilities with MAOP at or above 20% SMYS are to be hydrostatically pressure tested, whether tested in place or re-tested, unless otherwise approved				
<u>Recording Device is required when pressure testing transmission facilities.</u>					

Note (3): Maximum test pressure on steel pipe with Design MAOP of 100 psig or greater should not exceed that designated by GTE or GSE.

Note (4): Refer to [STLP 2.2 Appendix A](#) Design Pressure - Steel Pipe Stock Code Table, for pressure that would result in stressing pipe to 30% SMYS. If the pipe being tested is not shown in this table, contact GTE, GSE, or local Gas Engineer for pressure determination.

Note (5): Leak test is required when non-hydrostatic testing is performed.

Appendix F - Farm Tap, Single Cut, 60 To 450 psig Inlet Pressure

F-1. Table F provides test pressure and test duration requirements for piping on a single cut farm tap.

Table F: Farm Tap, Single Cut - 60 To 450 psig Inlet Pressure

	Material	Design MAOP	Test	Test Pressure	Test Duration	Test Pressure Measurement
From Main to Inlet of Regulator	Inlet Service	> 100 psig	Leak Test Note (1)	Minimum 1.5 x Design MAOP OR Maximum 675	Minimum 10 Minutes	Gauge or Recording Device can be used to

UNCONTROLLED IF PRINTED

	Line < 2"			psig (if Design MAOP is unknown)		measure test pressures.
	Inlet Service Line ≥ 2"	> 100 psig	Leak Test	Minimum 100 psig	Minimum 1 Hour	
			Strength Test	Minimum 1.5 x Design MAOP OR Maximum 675 psig (if Design MAOP is unknown)	Minimum 1 Hour	
From Main to Outlet of Farm Tap	Note: All of the piping from the main to the outlet of the farm tap can be tested together at the inlet service line test pressure. See Note (2) and Note (3).					
Outlet Service Line < 2"	Test the same as Service Lines - Less than 2" Diameter; Plastic or Steel. See Table A . See Note (4).					
Outlet Service Line ≥ 2"	Test the same as Main - See Table B if plastic service. See Table C OR Table D if steel service. See Note (4).					

Note (1): The single Leak Test satisfies requirements in that it will ensure there are no hazardous leaks and qualifies the Design MAOP of the service line.

Note (2): Regulators and relief valves must be removed during the pressure test. If test pressure is 1,000 psig or more, Pete's plugs must also be removed.

Note (3): Regulators, relief valves and Pete's plugs connections shall be checked for leaks with leak detection fluid or leak detection instrument at current operating pressure once service has been reinstated.

Note (4): If the outlet service has both steel and plastic pipe, then test to the plastic pipe requirements.

Appendix G - Farm Tap, Double Cut, 451 To 1,000 psig Inlet Pressure

G-1. Table G provides test pressure and test duration requirements for piping on a double cut farm tap.

Table G: Farm Tap, Double Cut, 451 To 1,000 psig Inlet Pressure

	Material	Design MAOP	Test	Test Pressure	Test Duration	Test Pressure Measurement
From Main to Inlet of 1st Cut Regulator	Inlet Service Line < 2" Note (5)	> 100 psig	Leak Test Note (1)	Minimum 1.5 x Design MAOP OR Maximum 1500 psig (if Design MAOP is unknown)	Minimum 10 Minutes	Gauge or Recording Device can be used to measure test pressures.
	Inlet Service Line ≥ 2"	> 100 psig	Leak Test	Minimum 100 psig	Minimum 1 Hour	
			Strength Test	Minimum 1.5 x Design MAOP	Minimum 1 Hour	
Piping Between Regulators	Steel	150 psig (Max inlet for 1805 Relief)	Leak Test Note (1)	Minimum 225 psig	Minimum 10 Minutes	Gauge or Recording Device can be used to measure test pressures.

UNCONTROLLED IF PRINTED

From Main to Outlet of Farm Tap	Note: All of the piping from the main to the outlet of the farm tap can be tested together at the inlet service line test pressure. See Note (2) and Note (3).
Outlet Service Line < 2"	Test the same as Service Lines - Less than 2" Diameter; Plastic or Steel. See Table A . See Note (4) below.
Outlet Service Line ≥ 2"	Test the same as Main - See Table B if plastic service. See Table C OR Table D if steel service. See Note (4) below.

Note (1): The single Leak Test satisfies requirements in that it will ensure there are no hazardous leaks and qualifies the Design MAOP of the service line.

Note (2): Regulators and relief valves must be removed during the pressure test. If test pressure is 1,000 psig or more, Pete's plugs must also be removed.

Note (3): Regulators, relief valves and Pete's plugs connections shall be checked for leaks with leak detection fluid or leak detection instrument at current operating pressure once service has been reinstated.

Note (4): If the outlet service has both steel and plastic pipe, then test to the plastic pipe requirements.

Note (5): A test pressure of 1,181 psig or greater on a 1-1/4 inch service line will stress the pipe to 20% SMYS or more. Service line shall be tested in accordance with [Table D - Steel](#).

- G-2. Farm tap on a gas pressure system with a Design MAOP greater than 1,000 psig shall be designed or reviewed by GTE.
- G-3. Pressure containing facilities similar to a farm tap located within gas storage fields and compressor plants shall be designed by GSE.
- G-4. Piping between regulators can be tested with the inlet piping, provided all of the fittings are rated for the testing pressure.

PRESSURE TESTING

October 1, 2021

PTST 2.1 Leak Test

1.0 Purpose

This document specifies leak test requirements for mains, services, fabricated units/assemblies, and farm taps in accordance with 49 CFR 192 Subpart J.

Test Pressure and Duration Tables ([PTST 1.1](#)) specify pressure test requirements for given pipe materials, sizes and lengths.

2.0 Scope

This document addresses the following:

[3.0 Target Audience](#)

[4.0 General](#)

[5.0 Leak Test Duration](#)

[6.0 Leak Test Procedure](#)

[7.0 Leak Test Records](#)

3.0 Target Audience

- Gas Engineering
- Gas Distribution Design Specialist
- Field Engineering Representatives
- Gas Field Personnel
- Gas Supervisors
- Gas Construction Services Personnel
- Gas Tech Engineering (GTE)
- Gas Storage Engineering (GSE)
- Gas Storage Field Supervisor
- Gas Storage Field Operators

4.0 General

- 4.1 All new, relocated or replaced pipeline segments shall be pressure tested to identify any hazardous leaks and establish a maximum allowable operating pressure (MAOP).
- 4.2 Combination leak/strength tests are used to establish or verify pipeline segments or facilities with design MAOP of:
 - 4.2.1 125 psig or 60 psig for PE segments.
 - 4.2.2 Less than 100 psig for steel segments.
- 4.3 Refer to [PTST 1, Section 6.0](#) Roles and Responsibilities.
- 4.4 Hydrostatic pressure test plans for transmission lines prepared by GTE or GSE will include leak test procedures and requirements that will differ from those within this document. See [PTST 2.3](#) Hydrostatic Pressure Testing.

5.0 Leak Test Duration

- 5.1 Service lines less than 2 inches in diameter (plastic and steel) shall be tested in accordance with [PTST 1.1 Table A](#).
- 5.2 PE mains and PE service lines 2 inch and larger with a Design MAOP of either 60 psig (MDPE) or 125 psig (HDPE) and steel mains and steel service lines 2 inch and larger

UNCONTROLLED IF PRINTED

with Design MAOP of less than 100 psig will have the required test duration determined by the pipe size and length as indicated in [PTST 1.1 Table B](#) or [PTST 1.1 Table C](#). The basis of this calculation is as follows:

- 5.2.1 For mains and 2 inch and larger service lines, the leak test duration shall be 5 minutes per inch of nominal pipe diameter per 100 feet of pipe length with minimum test duration as listed below for the specific pipe diameter. See [Table 1](#) below.
- 5.2.2 When determining the required test duration, round the actual footage of pipe to be tested up to the next 100-foot increment. (i.e., 25 feet would be rounded up to 100 feet).
- 5.2.3 Calculate the required leak test duration for the pipe size and length to be tested. The maximum required leak test duration is 8 hours regardless of the additional footage of pipe to be tested.
 - 1. *Example: 4" pipe size and 1,500 ft. length to be tested.* The duration calculation would be 5 min x 4" x 15 = 300 minutes (5 hours). In this case, the minimum required leak test duration is 5 hours.
 - 2. *Example: 4" pipe size and 4,000 ft. length to be tested.* The duration calculation would be 5 min x 4" x 40 = 800 minutes (13 hours 20 mins). In this case, the minimum required leak test duration is the maximum duration of 8 hours.
- 5.2.4 The leak test pressure can be left on longer than the required test duration with the possible exception for service lines. The actual test duration time shall be recorded on the appropriate test records. See [PTST 1 Section 14.0](#) Test Records.
 - 1. Service lines with 175 psi rated meter valve that are being leak tested at a pressure greater than 200 psig shall have a maximum duration of no more than 2 hours. The test pressure shall be relieved or lowered to under 200 psig within the 2 hours. Refer to [PTST 1 Paragraph 10.6.1](#) for meter valve limitations
- 5.3 GTE or GSE shall specify the duration and pressure for leak tests performed during hydrostatic pressure testing of transmission lines.
- 5.4 When testing main segments containing different pipe sizes as a single test:
 - 5.4.1 Calculate the required leak test duration for each pipe size in same manner as in [Section 5.2](#) above. Required test duration is the sum of the calculated durations, not to exceed 8 hours.
 - 1. *Example: 10 feet of 4" pipe is connected to 2,000 feet of 2" pipe.* The required minimum duration would be: 20 min for 4" + (10 min. x 2000'/100' = 200 min) for 2" = 220 minutes. (3 hrs. 40 min.)
 - 2. *Example: 200 feet of 4" pipe is connected to 2,000 feet of 6" pipe.* The required minimum duration would be: (20 x 200/100) + (30 x 2000/100) = 1240 minutes (10 hrs. 40 min). In this case, the minimum required leak test duration is the maximum duration of 8 hours.
- 5.5 Table 1 provides the minimum test duration for pipe of a specific diameter.

Table 1: Minimum Leak Test Duration

Pipe Size	≤ 2"	4"	6"	8"	10"	12"	14"	16"	18"
-----------	------	----	----	----	-----	-----	-----	-----	-----

Time per 100 ft. of Pipe	10 Min.	20 Min.	30 Min.	40 Min.	50 Min.	60 Min.	70 Min.	80 Min.	90 Min.
Minimum Duration	10 Min.	20 Min.	30 Min.	40 Min.	50 Min.	60 Min.	70 Min.	80 Min.	90 Min.

5.6 The minimum required leak test duration for steel mains and service with Design MAOP of 100 psig or greater is 1 hour as indicated in [PTST 1.1 Table D](#). These mains and service lines require a separate leak test and strength test.

5.7 The test period begins after the test pressure has stabilized.

6.0 Leak Test Procedure

6.1 Isolate and seal all pipe ends using caps or fittings.

6.2 The mechanical recording chart, electronic pressure recording device or calibrated dead weight tester should be installed and recording prior to the initial pressurization to:

6.2.1 Verify operation of the recorder, and

6.2.2 Verify that the correct pressure is being recorded.

6.2.3 A test gauge or calibrating gauge may be used to verify accuracy of the recording device if there is question.

6.3 If the test segment will be blown down following the test, then the pressure recording chart, electronic pressure recording device or calibrated dead weight tester should be in operation at the initial start of the blow down to verify operation of the recorder.

6.3.1 If the test segment is not being blown down at the completion of the test, then document on the chart.

6.4 Fill test segment with test medium.

6.4.1 *Compressed air*: The air may be warmer than the pipe, causing an initial pressure drop in the first minutes or hours of the test as the air cools. If the pipe is exposed to sunlight or warm weather, then an increase in pressure may occur.

6.4.2 *Nitrogen*: Nitrogen may be cooler than the pipe but as the nitrogen warms the pressure will increase. If using nitrogen from a liquid transport truck, then ensure that only vaporized nitrogen is introduced in the pipe.

6.4.3 *Water*: Follow procedures in [PTST 2.3](#) Hydrostatic Pressure Testing.

6.4.4 It is critical that the temperature of the test medium and pipe be allowed to equalize before initiating the test.

6.5 Once the desired leak test pressure is reached and stabilized, hold the pressure on the segment for the required test duration as a minimum.

6.6 If the pressure does not stabilize check for leaks and repair any leaks found. Initiate the leak test process as indicated in [6.3](#) above.

6.7 The person responsible for the test shall ensure and document that the recording device has been zeroed prior to beginning the test. Additionally, the person responsible for the test shall document, the reason for any pressure fluctuation, such as temperature, vibration, vandalism, leak, etc., once the test duration has begun. Fluctuation shall be documented in the Comments section on the pressure test stamp. Refer to [PTST 1 Section 8.1.2.4](#) if recording device has digital display.

6.8 Where a separate leak and strength test is required, the strength test will follow a successful leak test.

- 6.9 If the pressure tested segments are not going to be immediately tied into the gas system, pressure may be left on the segment until the final tie in is made.
- 6.10 Tie-in joints shall be leak tested with leak detection solution or leak detection instrument at the current operating pressure.

7.0 Leak Test Records

- 7.1 Each leak test performed on a main or fabricated unit shall be documented on the appropriate Ameren Illinois forms. See [PTST 3](#) for copy of LTF (Leak Test Form) or LSTF (Leak Strength Test Form).
- 7.2 Refer to [PTST 1](#) for test record requirements.

End of Instructions.

Operator Qualification (OQ) Required?

YES

0561: Pressure Test - Nonliquid Medium - MAOP Less than 100 Psi

0571: Pressure Test - Nonliquid Medium - MAOP Greater than or Equal to 100 Psi

0581: Pressure Test - Liquid Medium

0591: Pressure Test - Leak Test at Operating Pressure

Appendices

NONE.

Attachments

NONE.

Compliance Requirements

49 CFR Part 192 Subpart J - Test Requirements.

49 CFR §192.619 Maximum allowable operating pressure: Steel or plastic pipelines.

Reference Documents

[PTST 1 Pressure Testing: Requirements](#)

[PTST 1.1 Pressure Testing: Test Pressure and Duration Requirement Tables](#)

[PTST 2.2 Pressure Testing: Strength Test](#)

[PTST 2.3 Pressure Testing: Hydrostatic Pressure Testing](#)

[PTST 2.4 Pressure Testing: Nitrogen Pressure Testing](#)

[PTST 3 Pressure Testing: Forms and Reference Materials](#)

Document Rescission

PTST 2.1 Pressure Testing: Leak Test, October 1, 2020

Revision Notes

UNCONTROLLED IF PRINTED

Location of Changes	Summary of Changes
Paragraph 4.2.1	125 psig or 60 psig replaces 100 psig for PE segments
Subsection 5.2	125 psig replaces 100 psig for HDPE pipe
Paragraph 5.2.4	Revised – The leak test pressure can be left on longer than the required test duration with the possible exception for service lines.
Paragraph 5.2.4 Item 1.	New – Service lines with 175 psi rated meter valves that are being leak tested at a pressure greater than 200 psig shall have a maximum duration of no more than 2 hours. The test pressure shall be relieved or lowered to under 200 psig within 2 hours. Refer to PTST 1 Paragraph 10.6.1 for meter valve limitations.

PRESSURE TESTING

October 1, 2020

PTST 2.2 Strength Test

1.0 Purpose

This document specifies the requirements for conducting strength testing of pipelines, fabricated units, or short sections of pipe in accordance with 49 CFR 192 Subpart J.

Test Pressure and Duration Tables ([PTST 1.1](#)) specify pressure test requirements for given pipe materials, sizes and lengths.

2.0 Scope

This document addresses the following:

[3.0 Target Audience](#)[4.0 General](#)[5.0 Test Medium](#)[6.0 Strength Test Procedure](#)[7.0 Strength Test Records](#)

3.0 Target Audience

- Gas Engineering
- Gas Construction Personnel
- Gas Supervisors
- Gas Construction Services Personnel
- Gas Integrity Management Personnel
- Gas Tech Engineering (GTE)
- Gas Storage Engineering (GSE)
- Gas Storage Field Supervisor
- Gas Storage Field Operators

4.0 General

- 4.1 When a separate strength test is required from [PTST 1](#), the strength test shall be performed after the leak test is successfully completed.
- 4.2 Strength test durations are shown in the following tables:
 - 4.2.1 [PTST 1.1 Table D](#) Steel Main, All Steel Pipe Sizes thru 30" with Design MAOP 100 PSIG or Greater
 - 4.2.2 [PTST 1.1 Table E](#) Fabricated Unit/Assembly or Short Section of Pipe
 - 4.2.3 [PTST 1.1 Table F](#) Farm Tap, Single Cut, 60 to 450 PSIG Inlet Pressure
 - 4.2.4 [PTST 1.1 Table G](#) Farm Tap, Double Cut, 451 to 1000 PSIG Inlet Pressure
- 4.3 Do not apply test pressure against a closed valve. In-line valves should be tested in the open position unless otherwise specified in the project procedures.
- 4.4 Maximum test pressure on steel pipe with Design MAOP of 100 psig or greater should not exceed that designated by GTE or GSE.

5.0 Test Medium

- 5.1 Water may be used as the test medium for any strength test. See [PTST 2.3](#) Hydrostatic Pressure Testing.

UNCONTROLLED IF PRINTED

5.2 Air, nitrogen, natural gas or combination of air and nitrogen may be used, provided the following maximum hoop stress limitations apply. See Table 1.

Table 1: Maximum Hoop Stress Allowed as Percent of SMYS

Class Location	Maximum Hoop Stress Allowed (% SMYS)	
	Natural Gas	Air or Nitrogen
1	80	80
2	30	75
3	30	50
4	30	40

5.2.1 For pipelines that operate at 30% or more of SMYS that are in a Class 1 or Class 2 location where there is a building intended for human occupancy within 300 feet of the pipeline, the strength test shall be as follows:

1. Hydrostatic test shall be conducted to a test pressure of 1.5 times the Design MAOP on the segment of pipe within 300 feet of such building. In no event may the test segment be less than 600 feet, unless the length of newly installed or relocated pipe is less than 600 feet.
2. However, if the building is evacuated while the test pressure exceeds 50% of SMYS, air or inert gas may be used as the test medium.

5.2.2 In a Class 1 or Class 2 location, each compressor station, regulator station and measuring station shall be tested to at least Class 3 location test requirement.

5.3 When strength testing with nitrogen, calculate the volume needed to fill the line, and schedule the necessary equipment. Nitrogen may be added to compressed air which was used for the leak test. See [PTST 2.4](#) Nitrogen Pressure Testing.

6.0 Strength Test Procedure

6.1 The mechanical recording chart, electronic pressure recording device or calibrated dead weight tester should be installed and recording prior to the initial pressurization to

6.1.1 Verify operation of the recorder, and

6.1.2 Verify that the correct pressure is being recorded.

6.1.3 A test gauge or calibrating gauge may be used to verify accuracy of the recording device if there is question.

6.2 Pressurize the pipe or fabricated segment to the required strength test pressure.

6.2.1 The official pressure gauge, mechanical chart recorder, electronic recording device, or calibrated dead weight tester may be located at any point on the line.

6.2.2 If using air, nitrogen or natural gas as a test medium, then locate the recording device near the compressor connection or fill end to prevent accidental over pressurization.

6.3 If water is used as a test medium, refer to [PTST 2.3](#) Hydrostatic Pressure Testing.

6.4 If a wide variation in ambient temperature is anticipated, install a recording temperature gauge, with probe buried at pipe level, adjacent to the pressure gauge.

6.5 If the test segment is going to be blown down following the test, the pressure recording chart, electronic pressure recording device or calibrated dead weight tester should be in operation at the initial start of the blow down to verify operation of the recorder. Docu-

ment on the chart or record, if the test segment is not being blown down at the completion of the test.

- 6.6 Once the desired strength test pressure is reached and stabilized, hold the pressure on the segment for at least the required test duration. If the pressure does not stabilize, check for leaks and repair any leaks found. Reestablish the strength test pressure for the required duration.
- 6.7 The person responsible for the test shall document the reason for any pressure fluctuation (temperature, vibration, vandalism, leak, etc.) once the test duration has begun. Fluctuation shall be documented in the Comments sections on the pressure test stamp. Refer to [PTST 1 Section 8.1.2.4](#) if recording device has digital display.
- 6.8 After completion of test, appropriately release the test medium. However, pressure may be left on the segment until the final tie-in.
- 6.9 Tie-in joints shall be leak tested with leak detection solution or leak detection instrument at the current operating pressure.

7.0 Strength Test Records

- 7.1 Each strength test shall be documented on the appropriate Ameren Illinois forms. See [PTST 3](#) for LSTF (Leak Strength Test Form).
- 7.2 Refer to [PTST 1](#) for test record requirements.

End of Instructions.

Operator Qualification (OQ) Required?

YES

0571: Pressure Test - Nonliquid Medium - MAOP Greater than or Equal to 100 Psi

0581: Pressure Test - Liquid Medium

Appendices

NONE.

Attachments

NONE.

Compliance Requirements

49 CFR 192 Subpart J - Test Requirements

49 CFR §192.619 Maximum allowable operating pressure: Steel or plastic pipelines.

Reference Documents

[PTST 1 Pressure Testing: Requirements](#)

[PTST 1.1 Pressure Testing: Test Pressure and Duration Requirement Tables](#)

[PTST 2.3 Pressure Testing: Hydrostatic Pressure Testing](#)

[PTST 2.4 Pressure Testing: Nitrogen Pressure Testing](#)

[PTST 3 Pressure Testing: Forms and Reference Materials](#)

Document Rescission

PTST 2.02 Pressure Testing: Strength Test, October 1, 2019.

Revision Notes

Location of Changes	Summary of Changes
Not applicable.	This is a new document.

PRESSURE TESTING

October 1, 2021

PTST 2.3 Hydrostatic Pressure Testing

1.0 Purpose

This procedure specifies the requirements for conducting hydrostatic pressure testing of pipelines, fabricated units, or short sections of pipe in accordance with environmental protection requirements and 49 CFR Part 192 Subpart J.

2.0 Scope

This document addresses the following:

[3.0 Target Audience](#)[4.0 General](#)[5.0 Environmental Protection Requirements](#)[6.0 Safety](#)[7.0 Prior to Hydrostatic Testing](#)[8.0 Filling with Water](#)[9.0 Pressurizing](#)[10.0 Depressurizing/Dewatering](#)[11.0 Spike Hydrostatic Pressure Test for Transmission Lines \(49 CFR §192.506\)](#)[12.0 Test Records](#)**3.0 Target Audience**

- Gas Engineering
- Gas Construction Personnel
- Gas Supervisors
- Gas Construction Services Personnel
- Gas Integrity Management Personnel
- Gas Tech Engineering (GTE)
- Gas Tech Services (GTE) Supervisors
- Gas Tech Services (GTE) Personnel
- Gas Storage Engineering (GSE)
- Gas Storage Field Supervisor
- Gas Storage Field Operators

4.0 General

- 4.1 GTE or GSE shall provide written hydrostatic testing and spiking testing procedures for each applicable project. These instructions will be part of the job packet and shall be reviewed with personnel responsible for performing and monitoring the test.
- 4.2 See [PTST 1, Section 7.0](#) Test Medium for test medium requirements.
- 4.3 A separate leak test is not required for hydrostatic pressure testing.

5.0 Environmental Protection Requirements

- 5.1 GTE or GSE will contact Ameren Environmental Services when planning a hydrostatic test to verify permitting and water testing requirements associated with hydrostatic testing and discharging.

UNCONTROLLED IF PRINTED

- 5.2 Ameren Illinois (AIC) has a blanket IL EPA Water Pollution Control Permit for the discharge of hydrostatic test water but that permit has specific requirements that must be met. A copy of this permit should be part of the final job packet when hydrostatic pressure testing is performed.
- 5.3 GTE or GSE, along with Ameren Environmental Services, will coordinate the required water sampling and testing.
- 5.4 Ameren Environmental Services will submit all required documentation to the appropriate IL EPA office. GTE or GSE shall provide Environmental Services with project-specific information (Table 1).

Table 1: Project-Specific Hydrostatic Test Information

Project-specific information	Description/example
General Location of Discharge Site(s)	e.g. Northeast side of Neil Street and Jones Rd
Project Description	e.g. New 12" from Marion to Johnston City
Scheduled Release Date(s)	Month/Day/Year
Estimated Duration of Release	Approximate hours
Source of Test Water	e.g. City of Marion water department
pH of Source Water	Obtain in advance from source of supply
Estimated Volume of Discharge	Gallons
Release Site(s)	Type of land, such as farmland, pasture, gravel yard, etc.
Site Coordinates of Discharge Site(s)	County, township, range, section, and road intersection if possible or GPS coordinates
Site Map	e.g. Would be to show the discharge location on a USGS Quadrangle Map. Ameren Environmental Services has previously taken the information supplied by the Engineer and created the Site Map to submit to the IL EPA

6.0 Safety

- 6.1 Restrict access to the test area (along and around the pipeline being hydrostatically tested) to only those persons needed to perform the test.
- 6.2 Conduct a Job Briefing identifying potential safety hazards associated with hydrostatic testing including the filling and discharge operations.
- 6.3 Anchor or restrain hydrostatic test water discharge piping to prevent excessive movement that could cause the line to separate at connections to couplings, valves, or other fittings.

7.0 Prior to Hydrostatic Testing

- 7.1 Before pipeline segment is hydrostatically tested, complete all nondestructive testing and/or all repairs.

- 7.1.1 Prior to performing a hydrostatic retest on existing transmission pipelines (i.e., to revalidate serviceability of the line) Integrity Management may consider running an in-line inspection tool to detect time-dependent defects.
- 7.2 Before filling with water, pipelines should be pigged to remove any debris.
- 7.3 Consider elevation differences:
 - 7.3.1 The lowest elevation point on the line will be subjected to the greatest pressure during the test due to the additional static head of water.
 - 7.3.2 The highest elevation point will have the least pressure during the test since it will have no additional pressure because of the weight of water.
 - 7.3.3 The static pressure of water is equal to 0.433 psig per foot of elevation.
 - 7.3.4 The intent is to subject the entire length of pipe to a pressure that meets or exceeds the minimum strength test requirement while not exceeding a pressure that is greater than the yield strength of the pipe.
- 7.4 GTE or GSE will determine the volume of water required and provide that information to the individual responsible for hydrostatic testing.
 - 7.4.1 Use water from a potable city distribution system whenever possible. Use check-valves in fill lines, as necessary, to prevent possible contamination of city water.
 - 7.4.2 If water is from a potable water source, the city operator should provide pH information.
 - 7.4.3 If water is from a lake, stream, or pond, the water shall be field tested prior to use. Use only if pH is between 6.0 and 9.0.
 - 7.4.4 If assistance is needed, contact Ameren Environmental Services.

Auxiliary tanks and pumps may be used as necessary to supplement the availability of city water and pressure.

8.0 Filling with Water

- 8.1 Install valves and fittings at the line inlet and outlet to control the water injection rate and air removal. Valves and fittings shall have a pressure rating equal to or exceeding the maximum test pressure.
- 8.2 Inject water into the line in a manner that most effectively eliminates air pockets left in the pipeline. The preferred manner is to inject the test water behind a pig, pushing the pig with water to the end of the pipeline.
 - 8.2.1 Other methods may be used as long as they effectively minimize the amount of air left in the pipeline.
- 8.3 Inject water at a steady rate such that the pig travels between 176 and 264 feet per minute (approximately 2 to 3 miles per hour). A water meter can be used to determine pig location and travel speed. Calculate pig speed as follows:

$$\text{Pig speed (feet per minute)} = \frac{\text{(Cubic feet per minute of water)}}{\text{(Cubic feet in one foot of pipe)}}$$

- 8.4 If an extreme drop in elevation is encountered along the route, then it may be necessary to apply back pressure at the discharge end.

- 8.5 When the pig reaches the end, continue discharging water through the vent lines until it runs free of any bubbles (entrapped air).
- 8.6 Fittings at the line outlet (end where the pig is received) should have valving allowing removal of the pig without introducing air into the line OR be arranged to allow reversal of the pig direction for water removal.

9.0 Pressurizing

- 9.1 Once the line has been filled with water and is free of entrapped air, use a hydrostatic test pump or portable pressure washer to increase pressure to the determined strength test pressure.
- 9.2 After the desired pressure is reached, monitor the recording gauge for about 15 minutes.
 - 9.2.1 If pressure drops steadily, check for potential leakage and repair.
 - 9.2.2 If pressure drops at first and then levels off, the cause is due to a change in the water temperature inside the pipe.
 - 9.2.3 GTE will specify required leak test duration.
- 9.3 After verifying a stable pressure, continue pressurizing as needed to reach the desired strength test pressure and start the recording gauge chart.
 - 9.3.1 Record on the pressure chart, or pressure log, the time, date, temperature, order number.
 - 9.3.2 If using a temperature recorder, record the time, date, and order number on the chart.
- 9.4 Continue the strength test for the required time duration. Although the pressure may vary, the pressure should **not** fall below the minimum required strength test pressure at any time during the test.
 - 9.4.1 Record the time and date the test was completed.
 - 9.4.2 The signature of the individual conducting the test, or the Ameren Illinois witness, should be on the chart, test log, or record.
 - 9.4.3 The serial number of the pressure recorder and/or temperature recorder should be documented on the appropriate chart and the calibration date of the recorder.
- 9.5 Any leaks or failures found during the test shall be noted on the test record.

10.0 Depressurizing/Dewatering

- 10.1 When testing is completed, relieve pressure through valves on test header.
- 10.2 Propel pigs with air pressure to dispel all water through discharge end.
 - 10.2.1 Control pig speed by maintaining back pressure at the discharge end through valve adjustment.
 - 10.2.2 A pig moving uniformly will create a steady pressure and a uniform length of water jet from the discharge piping.
 - 10.2.3 Pig speed on discharge should be the same speed as filling.
- 10.3 Release discharge of test water onto the release site should be controlled. The AIC blanket IL EPA Water Pollution Control Permit requires that provisions be made to pre-

vent the flow of water into ditches, streams, or ponds. Test water should be allowed to seep into the ground without causing erosion.

10.4 Contact Environmental Services for hydrostatic test discharge water sampling kits and instructions for sampling, sample preservation, and shipment to laboratory. The discharge test water will be generally analyzed for oil, grease, pH, total suspended solids, dissolved and total iron per the blanket IL EPA Water Pollution Control Permit.

10.5 Following initial water discharge, the pipeline should be pigged as many times as necessary to assure removal of free water. Little, if any, free water should be discharged on the final discharge/drying pig run.

11.0 Spike Hydrostatic Pressure Test for Transmission Lines (49 CFR §192.506)

11.1 Spike Test Requirements

11.1.1 Whenever a segment of steel transmission pipeline is spike tested under this part:

1. Use water as medium.
2. Have baseline test pressure of at least 1.5 times the design MAOP.
3. Hold at or above baseline test pressure for a minimum of 8 hours.
4. After the test pressure stabilizes at the baseline pressure and within the first 2 hours, subject and hold the spike test pressure test for at least 15 minutes after the spike test pressure stabilizes.

12.0 Test Records

12.1 Each strength test shall be documented on the appropriate Ameren Illinois forms. See [PTST 3](#) for Hydrotest Strength Test Form.

12.2 Refer to [PTST 1](#) for test record requirements.

End of Instructions.

Operator Qualification (OQ) Required?

YES

0581: Pressure Test - Liquid Medium

Appendices

NONE.

Attachments

NONE.

Compliance Requirements

49 CFR Part 192 - Amendments published October 1, 2019 in 84 FR 52245:

§192.18 How to notify PHMSA.

§192.506 Transmission lines: Spike hydrostatic pressure test.

§192.619 Maximum allowable operating pressure: Steel or plastic pipelines.

UNCONTROLLED IF PRINTED

§192.620 Alternative maximum allowable operating pressure for certain steel pipelines.

49 CFR Part 192 Subpart J - Test Requirements

Reference Documents

[PTST 1 Pressure Testing: Requirements](#)

[PTST 1.1 Pressure Testing: Test Pressure and Duration Requirement Tables](#)

[PTST 2.1 Pressure Testing: Leak Test](#)

[PTST 3 Pressure Testing: Forms and Reference Materials](#)

Document Rescission

PTST 2.3 Pressure Testing: Hydrostatic Pressure Testing, April 1, 2021.

Revision Notes

Location of Changes	Summary of Changes
2.0 Scope – Section 7.0	Revised title – Prior to Hydrostatic Testing
Section 4.0	Added Subsection 4.3 - Separate leak test is not required when hydrostatic pressure test is performed.
Section 7.0	Changed to Prior to Hydrostatic Testing
Section 7.0	Removed – Place test gauges or recording devices as needed near the highest and lowest points on the pipeline being tested.
Paragraph 9.2.2	Revised to - If pressure drops at first and then levels off, the cause is due to a change in the water temperature inside the pipe.
Paragraph 9.3.1 and 9.3.2	Removed "project name"
Paragraph 11.1.1	Item 3 – Changed to "at or above baseline pressure"
Subsection 12.1	Hydrotest Strength Test Form replaces LSTF (Leak Strength Test Form)

PRESSURE TESTING

December 15, 2021

PTST 2.4 Nitrogen Pressure Testing

1.0 Purpose

This procedure provides requirements for nitrogen pressure testing mains and service lines in accordance with 49 CFR Part 192 Subpart J.

2.0 Scope

This document addresses the following:

[3.0 Target Audience](#)

[4.0 General](#)

[5.0 Properties of Nitrogen](#)

[6.0 Use of Compressed Gas Cylinder](#)

[7.0 Cylinder Requirements](#)

3.0 Target Audience

- Gas Engineering
- Gas Tech Engineering (GTE)
- Gas Field Personnel
- Gas Supervisors
- Gas Construction Services personnel
- Gas Tech Services (GTS) Supervisors
- Gas Tech Services (GTS) Personnel
- Gas Storage Engineering (GSE)
- Gas Storage Field Supervisor
- Gas Storage Field Operators

4.0 General

- 4.1 All valves, gauges, hoses and fittings used for nitrogen pressure testing shall have pressure ratings that exceed the test pressure and the pressure of the nitrogen tank used.

5.0 Properties of Nitrogen

- 5.1 Nitrogen is an inert gas. It is colorless, odorless, non-toxic, non-combustible and non-corrosive.
- 5.2 Gaseous nitrogen is extremely dry and absorbs moisture.
- 5.3 Nitrogen should be used as a safe medium for pressure testing mains and service lines and as a purge slug.

6.0 Use of Compressed Gas Cylinder

- 6.1 An adjustable regulator with gauges for upstream and downstream pressures is required for pressure testing applications.
- 6.2 Regulator, valves, gauges, hoses, and fittings designed and rated for the intended application and pressure shall be used.

7.0 Cylinder Requirements

- 7.1 When nitrogen pressure testing relatively small volumes of piping, use the Cylinder Estimation Graph ([Table 1](#)) to determine the number of required cylinders.

UNCONTROLLED IF PRINTED

7.1.1 The Cylinder Estimation Graph assumes starting with a 100 psig air test and provides at least one more cylinder than is required.

7.1.2 *Example:* How many cylinders of nitrogen are required to test 1,400 feet of 3-inch pipe at 1,080 psig?

1. Follow the arrows to find 1,400 ft on the Pipe Length scale. Go vertically to the 3" Nominal Diameter line, and then go horizontally to the 1,080 psig Test Pressure line.
2. On the top scale, read the number of cylinders required for the corresponding cylinder size: 34 cylinders (Cylinder Size 226/2200) OR 20 cylinders (Cylinder Size 370/2400).

Table 1: Cylinder Estimation Graph

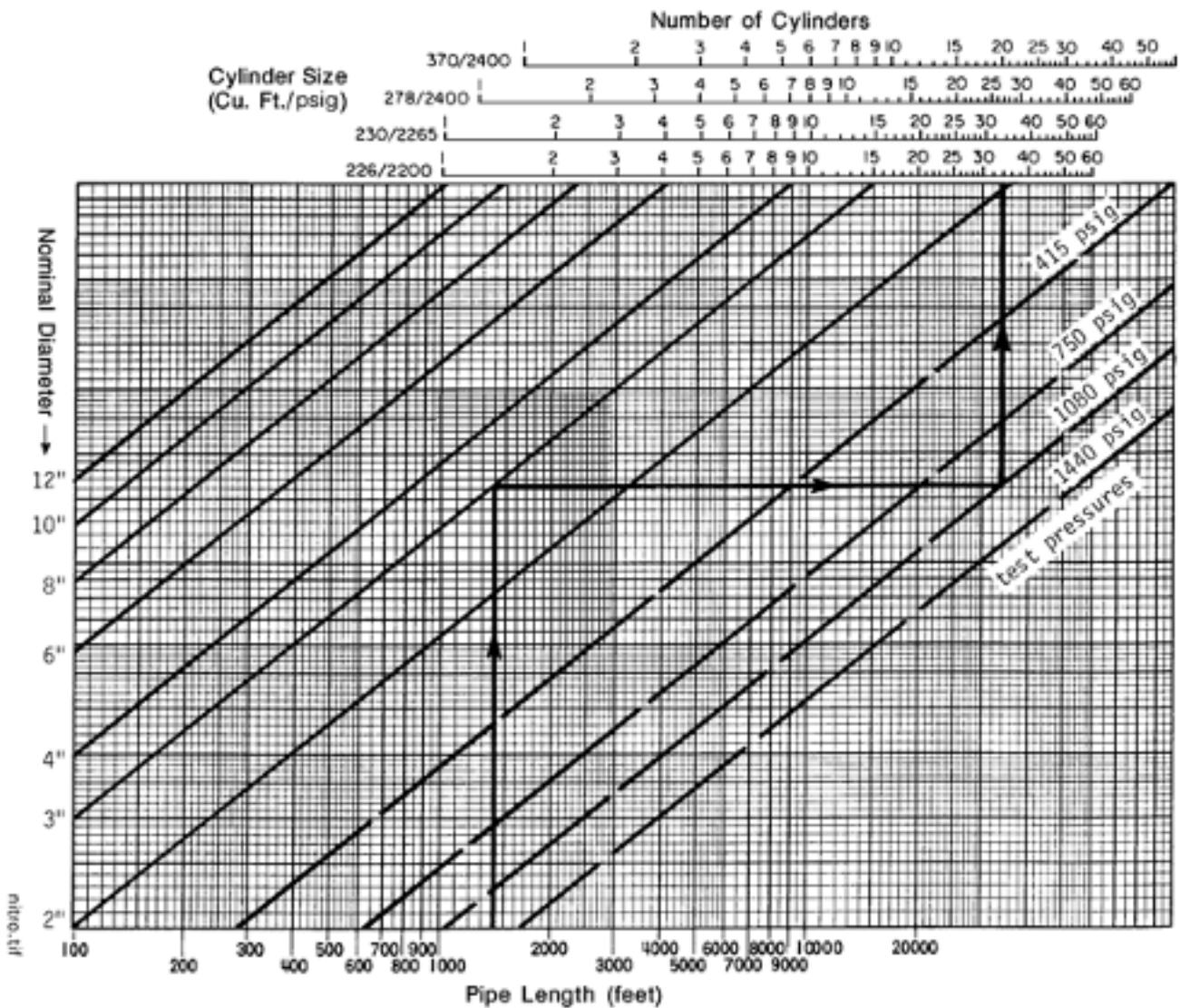

7.2 If more than 60 cylinders are required to establish the desired test pressure, then purchasing compressed nitrogen in a tube trailer may be a more economical alternative.

End of Instructions.

UNCONTROLLED IF PRINTED

Operator Qualification (OQ) Required?

YES

0561: Pressure Test - Nonliquid Medium - MAOP Less than 100 Psi

0571: Pressure Test - Nonliquid Medium - MAOP Greater than or Equal to 100 Psi

Appendices

NONE.

Attachments

NONE.

Compliance Requirements

49 CFR Part 192 Subpart J - Test Requirements

Reference Documents

[PTST 1 Pressure Testing: Requirements](#)

[PTST 1.1 Pressure Testing: Test Pressure and Duration Requirement Tables](#)

[PTST 3 Pressure Testing: Forms and Reference Materials](#)

Document Rescission

PTST 2.4 Pressure Testing: Nitrogen Pressure Testing, October 1, 2021.

Revision Notes

Location of Changes	Summary of Changes
Subsection 7.1	Replaced the Cylinder Estimation Graph that was mistakenly removed from October 1, 2021 Update.
Subsection 7.2	Removed the reference to Section 8.0 which was removed on October 1, 2021 Update

PRESSURE TESTING

October 1, 2021

PTST 2.5 MAOP Determination

1.0 Purpose

This document outlines determination methods for establishing maximum allowable operating pressure (MAOP) on gas pipeline facilities owned and operated by Ameren Illinois (AIC) in accordance with 49 CFR Part 192 Subpart J and Subpart L.

2.0 Scope

This document addresses the following:

[3.0 Target Audience](#)

[4.0 General](#)

[5.0 MAOP for Steel or Plastic Pipelines \(49 CFR §192.619\)](#)

[6.0 MAOP for High Pressure Distribution Systems](#)

[7.0 MAOP for Low Pressure Systems](#)

[8.0 Records](#)

[9.0 Alternative MAOP for Certain Pipelines](#)

3.0 Target Audience

- Gas Engineering
- Gas Tech Engineering (GTE)
- Gas Integrity Management
- Gas Storage Engineering (GSE)
- Gas Tech Services Supervisors
- Gas Storage Field Supervisors
- Gas Supervisors

4.0 General

- 4.1 49 CFR Part 192 requires that each section of pipeline OR each segment of a distribution system have a MAOP established.
- 4.2 Federal pipeline safety standards 49 CFR §§ 192.607, 192.619, 192.620, 192.621, 192.623, and 192.624 list the factors to review in determining the MAOP.
- 4.3 Prior to 49 CFR Part 192, MAOP was determined by the Illinois Commerce Commission, General Order No. 192, Rule for the Construction and Operations of Gas Transmission and Distribution Piping Systems, June 1967.

5.0 MAOP for Steel or Plastic Pipelines (49 CFR §192.619)

- 5.1 For new pipelines, MAOP should be determined by the design pressure of the weakest element in the system.
- 5.2 For in-service steel pipelines, MAOP is established by determining the lowest of the following:
 - 5.2.1 The design pressure of the weakest element in the system.
 - 5.2.2 The pressure obtained by dividing the test pressure after construction by the appropriate class location factor (Table 1).

UNCONTROLLED IF PRINTED

Table 1: MAOP Determination - Class Location Factors

Class Location	Steel pipe (operated at 100 psig or more)				Plastic pipe (all locations)
	Installed Before Nov. 12, 1970	Installed On or After Nov. 12, 1970 and Before July 1, 2020	Installed On or After July 1, 2020	Covered Under 49 CFR 192.14	
1	1.1	1.1	1.25	1.25	Test pressure is divided by a factor of 1.5.
2	1.25	1.25	1.25	1.25	
3	1.4	1.5	1.5	1.5	
4	1.4	1.5	1.5	1.5	

5.2.3 The highest actual operating pressure between July 1, 1965 and July 1, 1970.

5.2.4 The maximum pressure considered safe by the operator after considering and accounting for records of material properties, including materials verified by material testing if applicable, and the history of the pipeline system, known corrosion and actual operating pressure history.

5.2.5 The highest actual operating pressure during the 5-year period preceding July 1, 1970. This pressure restriction applies unless the segment was tested in accordance with the factors shown in Table 1 between July 1, 1965 and July 1, 1970 or the segment was uprated in accordance with Uprating section of Part 192.

5.3 In accordance with 49 CFR §192.624, the maximum allowable operating pressure of all steel transmission pipeline segments must be reconfirmed if certain conditions are met.

5.4 For in-service PE pipelines the MAOP is the test pressure divided by a factor of 1.5.

6.0 MAOP for High Pressure Distribution Systems

6.1 The MAOP cannot exceed the lowest of the following pressures, as applicable:

6.1.1 Design pressure of the weakest element in the segment as determined by Pipe Design and Design of Pipeline Components sections of 49 CFR Part 192.

6.1.2 Pressure determined by the operator to be the maximum safe pressure after considering the history of the segment, particularly known corrosion and the actual operating pressure.

6.2 Overpressure protection devices shall be installed to prevent the MAOP from being exceeded above the allowable maximum emergency pressure.

7.0 MAOP for Low Pressure Systems

7.1 On low pressure systems where gas is delivered to the customer with no service regulator, the MAOP is determined by the operator based on the maximum pressure which can safely be delivered to the customer.

8.0 Records

8.1 The MAOP records on gas facilities are retained and maintained in electronic and paper format.

8.2 In accordance with 49 CFR §192.619 (4)(f), operators of onshore steel transmission pipelines must make and retain records necessary to establish and document the MAOP of each pipeline segment in accordance with 49 CFR §192.619 paragraphs (a) through (e) as follows:

- 8.2.1 Operators of pipelines in operation as of July 1, 2020 must retain any existing records establishing MAOP for the life of the pipeline;
- 8.2.2 Operators of pipelines in operation as of July 1, 2020 that do not have records establishing MAOP and are required to reconfirm MAOP in accordance with §192.624, must retain the records reconfirming MAOP for the life of the pipeline; and
- 8.2.3 Operators of pipelines placed in operation after July 1, 2020 must make and retain records establishing MAOP for the life of the pipeline.

9.0 Alternative MAOP for Certain Pipelines

9.1 The MAOP as determined by using alternate design factors and alternate test factors in accordance with Table 2:

Table 2: Alternative MAOP Design and Test Factors

Class Location	Alternative Design Factor (F)	Alternative Test Factor	Comment
1	0.80	1.25	
2	0.67	1.5	
		1.25	Segments installed prior to December 22, 2008
3	0.56	1.5	

Reference: PHMSA FAQ available online [here](#).

End of Instructions.

Operator Qualification (OQ) Required?

NO.

Appendices

NONE.

Attachments

NONE.

Compliance Requirements

49 CFR Part 192 - Amendments published October 1, 2019 in 84 FR 52245:

§192.18 How to notify PHMSA.

§192.607 Verification of Pipeline Material Properties and Attributes: Onshore steel transmission pipelines.

§192.619 Maximum allowable operating pressure: Steel or plastic pipelines.

§192.624 Maximum allowable operating pressure reconfirmation: Onshore steel transmission pipelines.

§192.712 Analysis of predicted failure pressure.

49 CFR Part 192 Subpart J - Test Requirements

UNCONTROLLED IF PRINTED

49 CFR Part 192 Subpart L - Operations

§192.607 Verification of Pipeline Material Properties and Attributes: Onshore steel transmission pipelines.

§192.619 Maximum allowable operating pressure: Steel or plastic pipelines.

§192.620 Alternative maximum allowable operating pressure for certain steel pipelines.

§192.621 Maximum allowable operating pressure: High-pressure distribution systems.

§192.623 Maximum and minimum allowable operating pressure; Low-pressure distribution systems.

§192.624 Maximum allowable operating pressure reconfirmation: Onshore steel transmission pipelines.

49 CFR §192.705 Transmission lines: Patrolling.

Reference Documents

NONE.

Document Rescission

PTST 2.5 Pressure Testing: MAOP Determination, October 1, 2020

Revision Notes

Location of Changes	Summary of Changes
Subsection 5.2	Added: steel, in-service steel pipelines
Subsection 5.4	New: For in-service PE pipelines the MAOP is the test pressure divided by a factor of 1.5.

PRESSURE TESTING

December 15, 2021

PTST 2.6 ASME Pressure Vessels

1.0 Purpose

- 1.1 This procedure is applicable to pressure testing and inspecting of ASME pressure vessels installed on the Ameren Illinois (AIC) natural gas system.
- 1.2 ASME pressure vessels, which may be identified by a certification stamp or tag physically attached to the vessel, have unique testing and inspection requirements that Ameren must document prior to placing them into service.
- 1.3 This procedure does not apply to pressure testing of prefabricated assemblies of standard pipe and fittings. These prefabricated assemblies are typically pressure tested in accordance with 49 CFR, Part 192, Subpart J and **PTST 1** Pressure Testing Requirements and **PTST 1.1** Test Pressure and Duration Tables. Examples of prefabricated assemblies that are not subject to this procedure include:
 - 1.3.1 Metering stations.
 - 1.3.2 Regulating stations.
 - 1.3.3 Valve stations.
 - 1.3.4 Pig launchers and receivers constructed from standard pipe and fittings.
 - 1.3.5 Prefabricated section of pipeline constructed of one or more joints of pipe, valves and/or fittings.

2.0 Scope

This document addresses the following:

[3.0 Target Audience](#)**[4.0 Regulatory Requirements for ASME Pressure Vessels](#)****[5.0 Testing and Inspection Requirements](#)****[6.0 Use of a Manufacturer's Pressure Test or Prior Pressure Test](#)****[7.0 Temporary Removal from Service](#)****[8.0 Relocation of An Existing Pressure Vessel](#)****[9.0 Records](#)**

Appendices:

[Appendix A - Inspection of ASME Pressure Vessels](#)**3.0 Target Audience**

- Gas Engineering
- Gas Tech Engineering (GTE)
- Gas Storage Engineering (GSE)
- Gas Supervisors
- Gas Construction Personnel
- Gas Tech Services (GTS) Personnel
- Gas Storage Field Personnel
- Gas Construction Services (GCS) Supervisors

UNCONTROLLED IF PRINTED

- Gas Tech Services (GTS) Supervisors
- Gas Storage Field (GSF) Supervisors
- Gas Construction Inspectors
- Gas Construction Services Contractor Supervisors

4.0 Regulatory Requirements for ASME Pressure Vessels

- 4.1 An ASME pressure vessel is a specify fabricated component which must be designed, constructed, tested in accordance with ASME BPVC Section VIII Division 1 or Section VIII Division 2 as follows:
- 4.1.1 Except for branch connections and assemblies of standard pipe and fittings joined by circumferential welds, the design pressure of each component fabricated by welding, whose strength cannot be determined, must be established in accordance with paragraph UG-101 of the ASME BPVC Section VIII Division 1.
- 4.1.2 Each prefabricated unit that uses plate and longitudinal seams must be designed, constructed, and tested in accordance with ASME BPVC as defined in either Section VIII Division 1 or Section VIII Division 2, except for the following:
1. Regularly manufactured butt-welding fittings.
 2. Pipe that has been produced and tested under a specification listed in Appendix B of 49 CFR, Part 192.
 3. Partial assemblies such as split rings and collars.
 4. Prefabricated units that the manufacturer certifies have been tested to at least twice the maximum pressure to which they will be subjected under the anticipated operating conditions

5.0 Testing and Inspection Requirements

- 5.1 A pressure vessel installed after July 14, 2004 is not subject to the strength testing requirements of §192.505(b), which requires pressure testing to Class 3 location for pipeline facilities located in compressor stations, regulator stations, and measurement stations. Provided the pressure vessel has been tested in accordance [Paragraph 4.1.1](#) or [Paragraph 4.1.2](#) with a test factor of at least 1.3 times MAOP.
- 5.2 A pressure vessel installed after July 14, 2004 but before October 1, 2021 is exempt from the pressure test durations requirements of 192.505(c) and (d) and 192.507(c), provided the pressure vessel has been tested according to the requirements of ASME BPVC Section VIII Division 1 or Division 2.
- 5.3 A pressure vessel installed on or after October 1, 2021 must be tested for at least the duration specified under 192.505 (c) or (d), 192.507 (c) or 192.509 (a) whichever is applicable for MAOP of the pipeline in which the pressure vessel is being installed.
- 5.4 Pressure vessels installed permanently or temporarily must be either:
- 5.4.1 Pressure tested by AIC after placed on its support at its final location either before or after tied-in to the pipeline facility. OR
 - 5.4.2 Pressure tested by AIC prior to installation. OR
 - 5.4.3 Pressure tested by the manufacturer in accordance with 192.153(e) and this procedure. Refer to Section 6.0 for conditions required to use the manufacturer's pressure test.

- 5.5 Pressure vessels that are tested prior to installation or where manufacturer's pressure tests are used, shall be inspected after being placed on its support structure at its final installation location. Inspection is to confirm the pressure vessel was not damaged during any prior operation, transportation or installation into the pipeline.
- 5.5.1 This inspection must be performed prior to operation but may be performed either before or after it has been tied into the pipeline.
- 5.5.2 The inspection must include visual inspection for damage to the pressure vessel at a minimum to include the inlets, outlets, and lifting locations.
- 5.5.3 If injurious defects that are an integrity threat are found, the pressure vessel must be either non-destructively tested, re-pressure tested, or remediated in accordance with [REPR 1](#) or with the applicable ASME BPVC Section VIII Division 1 or ASME BPVC Section VIII Division 2 requirements. Injurious defects may include:
1. Dents
 2. Gouges
 3. Bending
 4. Corrosion
 5. Cracking
- 5.5.4 Inspection Form in Appendix A shall be used to document the inspection and associated remediation if required. AIC should consult with a certified service provider and/or inspector if remediation is required for an ASME pressure vessel.

Governing requirements and authorities for repairs:

- The Illinois Boiler and Pressure Vessel Safety Division (BPVSD) has jurisdiction over the construction, installation, operation, inspection, and repair of pressure vessels and maintains an online list of licensed repair agents.
- While newly fabricated pressure vessels are covered by ASME BPVC, repairs to ASME pressure vessels are covered by the requirements in the National Board Inspection Code (NBIC) or API 510 "Pressure Vessel Inspection Code".

6.0 Use of a Manufacturer's Pressure Test or Prior Pressure Test

- 6.1 A pressure vessel's manufacturer's initial pressure tests may be used provided the pressure vessel is newly manufactured and installed on or after October 1, 2021.
- 6.1.1 An initial pressure test from the manufacturer or other prior pressure tests on new or existing pressure vessels may also be used for a vessel temporarily installed in the pipeline facility in order to complete a testing, integrity assessment, repair, odorization or emergency response-related task including noise or pollution abatement:
1. The manufacturer's pressure test must meet the minimum requirements contained in [Section 5.0](#) Testing and Inspection requirements.
 2. AIC must inspect the pressure vessel after installation and remediate any injurious defects.

3. The temporary pressure vessel must be promptly removed after completion of the task.
4. If operational or environmental constraints require leaving the pressure vessel in place longer than 30 days, AIC must notify PHMSA and the ICC.
 - 4a. The Supervising Engineer shall notify the Manager, Pipeline Safety Compliance when it is apparent the pressure vessel will remain in place for more than 30 days.
 - 4b. The Supervising Engineer will provide the details as to the constraints preventing the removal.
 - 4c. The Manager, Pipeline Safety Compliance, shall provide the electronic mail notification to PHMSA via informationResourcesManager@dot.gov; and
 - 4d. Notify the PCC by phone or email

7.0 Temporary Removal from Service

- 7.1 An existing pressure vessel that is temporarily removed from a pipeline facility to complete a testing, integrity assessment, repair, odorization, or emergency response-related task including noise or pollution abatement, and then re-installed at the same location, must be inspected in accordance with [Subsection 5.5](#). A new pressure test is not required provided no damage or threats to the operational integrity of the pressure vessel were identified during the inspection and the MAOP of the pipeline is not increased.

8.0 Relocation of An Existing Pressure Vessel

- 8.1 Pressure vessels which are relocated on or after October 1, 2021 must meet the following requirements:
 - 8.1.1 The pressure vessel must be designed and constructed in accordance with the requirements of 9 CFR Part 192 in place at the time the vessel is returned to operational service at the new location.
 - 8.1.2 The pressure vessel must be pressure tested by AIC in accordance with the testing and inspection requirements applicable to newly installed pressure vessels.
 - 8.1.3 An existing pressure vessel being temporarily installed at a new location must be meet the requirements of [Section 6.0](#) Temporary Installation.

9.0 Records

- 9.1 Tests, inspection and repair records for a pressure vessel shall be kept for the operational life of the pressure vessel. Refer to [PTST 1 Section 14.0](#) for test record requirements.
- 9.2 Inspection record shall be documented on the Inspection of ASME Pressure Vessel Form as shown in [Appendix A](#).

End of Instructions.

Operator Qualification (OQ) Required?

YES

0201 Visual Inspection of Installed Pipe and Components for Mechanical Damage

UNCONTROLLED IF PRINTED

0211 Measure and Characterize Mechanical Damage on Installed Pipe and Components

Appendices

Appendix A – Inspection of ASME Pressure Vessels

Attachments

NONE.

Compliance Requirements

§192.153 Component Fabricated by Welding

ASME BPVC Section VIII, Division 1

ASME BPVC Section VIII, Division 2

Reference Documents

PTST 1 Pressure Testing – Requirements

PTST 1.1 Pressure Testing – Test Pressure and Duration Tables

Document Rescission

NONE.

Revision Notes

Location of Changes	Summary of Changes
Appendix A	Correct copy of Inspection of ASME Pressure Vessels Form

Appendix A - Inspection of ASME Pressure Vessel Form.



INSPECTION OF ASME PRESSURE VESSELS
In Accordance with §192.153(e)

Purpose

This Form documents visual inspections of ASME Pressure Vessels for potential damage resulting from transportation and installation or other conditions which potentially affect the integrity of the pressure vessel. This inspection must be performed after the relocated pressure vessel has been installed in its final location but prior to placing it in service. The inspection may occur before or after it has been tied into the pipeline.

Instructions

Visually inspect all locations on the Pressure Vessel shown for all defects show. Note "Y" if a defect was observed and "N" if no defects was observed.

Pressure Vessel Locations Inspected	Potentially Injurious Defects Observed -- Indicate by Y or N					
	Dents	Gouges	Bending	Cracking	Corrosion	Note Any Other Observed Defects
Inlets	<input type="checkbox"/>	<input type="checkbox"/>	<input type="checkbox"/>	<input type="checkbox"/>	<input type="checkbox"/>	<input type="checkbox"/>
Outlets	<input type="checkbox"/>	<input type="checkbox"/>	<input type="checkbox"/>	<input type="checkbox"/>	<input type="checkbox"/>	<input type="checkbox"/>
Lifting Locations	<input type="checkbox"/>	<input type="checkbox"/>	<input type="checkbox"/>	<input type="checkbox"/>	<input type="checkbox"/>	<input type="checkbox"/>
Structural Supports	<input type="checkbox"/>	<input type="checkbox"/>	<input type="checkbox"/>	<input type="checkbox"/>	<input type="checkbox"/>	<input type="checkbox"/>
Body	<input type="checkbox"/>	<input type="checkbox"/>	<input type="checkbox"/>	<input type="checkbox"/>	<input type="checkbox"/>	<input type="checkbox"/>
Other (specify: _____)	<input type="checkbox"/>	<input type="checkbox"/>	<input type="checkbox"/>	<input type="checkbox"/>	<input type="checkbox"/>	<input type="checkbox"/>

For any potentially injurious defects were observed above, note how remediated:

- (1) Non-destructive testing If Y, attach all NDT testing results and conclusions documentation
- (2) Re-pressure testing If Y, attach pressure test records in accordance with Ameren Procedure PTST 3 Form 02
- (3) Repaired if Y, attach all testing, analysis, and repair documentation

Inspection Performed By: _____

Date Inspected: _____

THIS FORM AND ALL DOCUMENTATION OF TESTING AND REPAIRS ARE REQUIRED TO BE RETAINED FOR THE LIFE OF THE PRESSURE VESSEL INSPECTED

PRESSURE TESTING

April 1, 2023

PTST 3 Forms and Reference Materials

Click on the links below to open the documents.

Forms

1. [Leak Test Form - LTF19](#)
2. [Leak & Strength Test Form - LSTF 19](#)
3. [Leak Test Form - LTF19 Fillable](#)
4. [Leak & Strength Test Form - LSTF19 Fillable](#)
5. [Hydrotest Strength Test Form](#)
6. [Hydrotest Strength Test Form - HSTF Fillable](#)
7. [Inspection of ASME Pressure Vessels Form](#)

Note: Leak Test Form LTF17 or LTF18 and Leak & Strength Test Form LSTF17 or LSTF 18 that are in job packets remain acceptable documentation. These forms remain acceptable until supply is depleted.

End of Section.

Document Rescission

PTST 3 Pressure Testing: Forms and Reference Materials, October 1, 2022

Revision Notes

Location of Changes	Summary of Changes
Forms	Added Leak Test Form - LTF19 – Fillable Leak & Strength Test Form - LSTF19 - Fillable Hydrotest Strength Test Form - HSTF - Fillable Updated Inspection of ASME Pressure Vessels Form

PUBL-Public Education

PUBLIC EDUCATION

October 1, 2022

PUBL 0 Table of Contents

PUBL 1 Public Education: Requirements

Section 1.0 Purpose
Section 2.0 Scope
Section 3.0 Target Audience
Section 4.0 Objective
Operator Qualification
Compliance Requirements
Reference Documents
Document Rescission

PUBL 2.1 Public Education: Public Notifications

Section 1.0 Purpose
Section 2.0 Scope
Section 3.0 Target Audience
Section 4.0 General
Section 5.0 Gas Safety Notifications to New Customers
Section 6.0 Gas Safety Notifications to the General Public
Section 7.0 Pipeline Emergency Response Notifications to Government Organizations
Section 8.0 Records
Operator Qualification
Compliance Requirements
Reference Documents
Document Rescission

PUBL 2.2 Public Education: Liaisons with Fire, Police and Public Officials

Section 1.0 Purpose
Section 2.0 Scope
Section 3.0 Target Audience
Section 4.0 General
Section 5.0 Periodic Contact

UNCONTROLLED IF PRINTED

Section 6.0 Mailing

Section 7.0 Face-to-Face Visit

Operator Qualification

Appendices

Appendix A - Sample Letter of Emergency Procedure

Appendix B - Sample Operator Page

Compliance Requirements

Reference Documents

Document Rescission

PUBL 3 Public Education: Forms and Reference Materials

References

Document Rescission

End Table of Contents.

Document Rescission

PUBL 0 Public Education: Table of Contents, October 1, 2020

Revision Notes

Location of Changes	Summary of Changes
PUBL 2.2	Removed Section 8.0 Natural Gas Emergency Procedure

1.0 Purpose

This document specifies requirements for Ameren Illinois' (AIC) public education program. The public education program complies with 49 CFR §192.616 and follows guidance and recommendations provided in API RP 1162.

2.0 Scope

This document addresses the following:

[3.0 Target Audience](#)

[4.0 Objective](#)

3.0 Target Audience

- Communications/Public Relations Department
- Public Awareness group

4.0 Objective

- 4.1 AIC has developed and implemented a Public Awareness Program in accordance with 49 CFR §192.616. See [PUBL 3](#).
- 4.1.1 The Public Awareness Program is a requirement, documented externally to the O&M Plan, which more specifically defines the content of an effective public education program. The public education program is based on the standards of the American Petroleum Institute's Recommended Practice RP 1162. See [Section 4.2](#) and [PUBL 2.1](#).
- 4.1.2 The Public Awareness Program addresses:
1. The stakeholder audience.
 2. The basic content of the message to be delivered.
 3. How often the message is delivered.
 4. Method of delivery.
 5. Program evaluation and effectiveness.
- 4.1.3 Note that the following Appendices referenced in the Public Awareness Program ([PUBL 3](#)) are subject to change, so they are not included in the O&M. These documents are maintained by and available through the Public Awareness group.
1. Appendix A: Self-Assessment
 2. Appendix B: Communication Methods
 3. Appendix C: Communication Committee
 4. Appendix D: Letter of Support
- 4.2 AIC has developed a public education program to provide consumers, affected public, local public officials, emergency officials, excavators and operators of facilities in the vicinity of our pipelines with information concerning the following topics:

- 4.2.1 Facts about natural gas.
 - 4.2.2 Importance of recognizing and reporting a natural gas emergency.
 - 4.2.3 How to report a gas emergency to Ameren Illinois.
 - 4.2.4 What actions to take in an emergency or when natural gas is detected.
 - 4.2.5 Importance of reporting any and all gas odors, no matter how slight of odor.
 - 4.2.6 Recognizing and reporting other types of hazards or potential hazards related to natural gas facilities, including customer's gas meter assembly.
 - 4.2.7 Causes and hazards of carbon monoxide.
 - 4.2.8 Identifying pipeline markers.
 - 4.2.9 Importance of reporting any damage or movement of gas facilities.
 - 4.2.10 The use of Illinois' One Call system, JULIE.
- 4.3 Local government agencies responsible for emergency response should be provided with information regarding natural gas emergency and procedures they should follow when responding.

End of Instructions.

Operator Qualification (OQ) Required?

NO.

Appendices

NONE.

Attachments

NONE.

Compliance Requirements

49 CFR §192.616 Public awareness.

API RP 1162 Public Awareness Programs for Pipeline Operators

Reference Documents

[PUBL 2.1 Public Education: Public Notifications](#)

[PUBL 3 Public Education: Forms and Reference Materials](#)

Document Rescission

PUBL 1 Public Education: Requirements, January 1, 2018.

Revision Notes

Location of Changes	Summary of Changes
Not applicable.	This is a new document.

PUBLIC EDUCATION

October 1, 2022

PUBL 2.1 Public Notifications

1.0 Purpose

This document describes Ameren Illinois' (AIC) public education program, designed to educate the public, customers, government organizations, emergency responders, and excavators on how to recognize and react to natural gas pipeline emergencies.

2.0 Scope

This document addresses the following:

[3.0 Target Audience](#)[4.0 General](#)[5.0 Gas Safety Notifications to New Customers](#)[6.0 Gas Safety Notifications to the General Public](#)[7.0 Pipeline Emergency Response Notifications to Government Organizations](#)[8.0 Records](#)**3.0 Target Audience**

- Communications/Public Relations Department
- Public Awareness group

4.0 General

- 4.1 The Public Education Program consists of notifications in the form of advertisements, annual mailings, billing messages, face-to-face meetings and presentations.
- 4.2 These notifications provide information on the purpose and reliability of a natural gas pipeline, awareness of potential hazards, prevention of natural gas pipeline damage and response to natural gas pipeline emergencies. See [PUBL 3](#) for copies of these notifications.

5.0 Gas Safety Notifications to New Customers

- 5.1 New customers will receive the Natural Gas Safety flyer with the first customer bill.
- 5.2 The flyer covers the following topics:
 - 5.2.1 Recognizing and Reporting Gas Leaks
 - 5.2.2 Responsible Digging Starts When You Call the One-Call System
 - 5.2.3 What You Should Know About Carbon Monoxide
 - 5.2.4 Water Heater Settings
 - 5.2.5 Storing and Using Common Flammable Household Items
 - 5.2.6 Natural Gas Piping, Fittings and Connections
 - 5.2.7 Customer-Owned Buried Gas Lines
 - 5.2.8 Pipeline Safety and Reliability
 - 5.2.9 Appliance, Equipment and Interior Piping

UNCONTROLLED IF PRINTED

6.0 Gas Safety Notifications to the General Public

- 6.1 Semi-annual notifications will be made to the general public in the AIC service area, which describe how to contact AIC if they smell gas. These notices will normally be given through newspaper advertisements.
- 6.2 Semi-annual mailings will also be sent to customers, which provide general natural gas safety information and instructions to call AIC if they smell gas. There is no charge when AIC responds to a gas odor call.
- 6.3 Residences located along the AIC natural gas transmission pipeline rights-of-way and natural gas storage fields will receive a direct mailing once every 2 years.
 - 6.3.1 This direct mailing will cover the following topics:
 1. Pipeline purpose and reliability.
 2. Awareness of hazards and prevention.
 3. Damage prevention.
 4. One-call requirements.
 5. Pipeline markers.
 6. How to contact Ameren Illinois for additional information.
- 6.4 Notifications are scheduled and initiated by the AIC Communications/Public Relations Department.

7.0 Pipeline Emergency Response Notifications to Government Organizations

- 7.1 The Public Awareness group is responsible for notifying the appropriate government organizations and providing them with information regarding a natural gas pipeline emergency.
- 7.2 Government organizations include city and county officials, law enforcement agencies, and fire departments.
- 7.3 Notifications shall include the following:
 - 7.3.1 Procedures to follow when notified of a natural gas emergency.
 - 7.3.2 A phone number for reporting a natural gas emergency to AIC.
 - 7.3.3 A confidential number for use by emergency response personnel such as the fire department and police may be included.
 - 7.3.4 Natural Gas and Electrical Safety Emergency Responder brochure.
 - 7.3.5 The availability of a gas safety training program. The program is available for presentation to fire and law enforcement personnel, government organizations, and community groups upon request.
- 7.4 Refer to [PUBL 2.2](#) for a sample annual notification letter and the emergency procedure.

8.0 Records

- 8.1 The AIC Public Awareness group will maintain the following records. All information is maintained on the Public Awareness SharePoint site:

- 8.1.1 A copy of the annual mailing and list of emergency responder training for fire, police, and other emergency agencies which include dates, locations, topics, and number of attendees.
 - 8.1.2 A list of face-to-face visits through Paradigm meeting and public education programs.
 - 8.1.3 A copy of the contractor mailing list and materials.
 - 8.1.4 A copy of the brochure and Ameren Illinois fact sheet sent to public officials once every 2 years.
- 8.2 AIC Communications/Public Relations shall maintain a copy of the semi-annual public notifications and customer mailings.
- 8.3 Copies of the annual notifications shall be maintained for a minimum of 5 years.

End of Instructions.

Operator Qualification (OQ) Required?

NO.

Appendices

NONE.

Attachments

NONE.

Compliance Requirements

49 CFR §192.616 Public awareness.

API RP 1162 Public Awareness Programs for Pipeline Operators

Reference Documents

[PUBL 2.2 Public Education: Liaisons with Fire, Police and Public Officials](#)

[PUBL 3 Public Education: Forms and Reference Materials](#)

Document Rescission

PUBL 2.01 Public Education: Public Notifications, April 1, 2020.

Revision Notes

Location of Changes	Summary of Changes
Not applicable.	This is a new document.

PUBLIC EDUCATION

October 1, 2022

PUBL 2.2 Liaisons with Fire, Police and Public Officials

1.0 Purpose

This document describes Ameren Illinois' (AIC) public education efforts and outreach for fire, police and public officials on how to recognize and react to natural gas pipeline emergencies.

2.0 Scope

This document addresses the following:

[3.0 Target Audience](#)

[4.0 General](#)

[5.0 Periodic Contact](#)

[6.0 Mailing](#)

[7.0 Face-to-Face Visit](#)

Appendices:

[Appendix A - Sample Letter of Emergency Procedure](#)

[Appendix B - Sample Operator Page](#)

3.0 Target Audience

- Communications/Public Relations Department
- Public Awareness group

4.0 General

- 4.1 An Ameren Illinois (AIC) representative shall make periodic contact with fire, police and public officials.
- 4.2 This periodic contact should include, a mailing to fire and police annually and public officials once every 2 years and/or a face-to-face visit.
- 4.3 AIC Public Awareness group is responsible for maintaining these liaisons.

5.0 Periodic Contact

- 5.1 This periodic contact is required to acquaint fire, police, and public officials with emergency procedures.
- 5.2 Appropriate fire, police and other public officials should be informed of the availability, capability and location of the AIC personnel, equipment, and materials for responding to gas pipeline emergencies. The 24-hour emergency service number should be provided.
- 5.3 The representative should stress the importance of the fire, police and public officials making immediate contact with AIC on all natural gas emergencies.
- 5.4 Paradigm meetings satisfy the periodic contact requirement for the fire, police, and public official in attendance. These meetings are held in the 1st quarter each year.

6.0 Mailing

UNCONTROLLED IF PRINTED

- 6.1 AIC Public Awareness' sample letter with First Responders Natural Gas Emergency Procedure used for the annual mailing are shown in [Appendix A](#).
- 6.2 AIC's Operator Page and Public Officials Along Transmission Pipelines and in Our Service Areas brochure are mailed to public officials every 2 years.
 - 6.2.1 See [Appendix B](#) for the sample Operator Page.
 - 6.2.2 See [PUBL 3](#) Forms and Reference Materials for copy of Public Officials Along Transmission Pipelines and in Our Service Areas brochure.
- 6.3 Public Awareness' sample letter, with First Responders Natural Gas Emergency Procedure and/or Operator Page along with the appropriate brochure should be mailed to Emergency Responders and Public Officials in the communities where AIC provides natural gas service. See [PUBL 3](#) Forms and Reference Materials for the appropriate brochure.
 - 6.3.1 Emergency Responders Along Transmission Pipelines and in our Service Areas.
 - 6.3.2 Public Officials Along Transmission Pipelines and in our Service Areas.

7.0 Face-to-Face Visit

- 7.1 The AIC representative should discuss the following during face-to-face visits:
 - 7.1.1 The responsibility and resources of each government organization that may respond to a gas pipeline emergency.
 - 7.1.2 Acquaint the Emergency Responders and public officials with AIC's ability in responding to a gas pipeline emergency.
 - 7.1.3 Identify the types of gas pipeline emergencies of which AIC notifies the Emergency Responders and/or public officials.
 - 7.1.4 Plan how AIC and Emergency Responders and public officials can engage in mutual assistance to minimize hazards to life and property.
- 7.2 Face-to-face visits should be documented by the AIC representative.

End of Instructions.

Operator Qualification (OQ) Required?

NO.

Appendices

[Appendix A - Sample Letter of Emergency Procedure](#)

[Appendix B - Sample Operator Page](#)

Attachments

NONE.

Compliance Requirements

49 CFR §192.616 Public awareness.

API RP 1162 Public Awareness Programs for Pipeline Operators

Reference Documents

[PUBL 3 Public Education: Forms and Reference Materials](#)

UNCONTROLLED IF PRINTED

Document Rescission

PUBL 2.2 Public Education: Liaisons with Public Officials, May 15, 2022

Revision Notes

Location of Changes	Summary of Changes
Section 8.0	Removed

Appendix A - Sample Letter of Emergency Procedure



October 1, 2022

Dear Emergency Responder,

Firefighters and law enforcement are typically first on the scene in an emergency and need to assess the situation quickly to respond effectively. It is critical that all first responders understand the properties of natural gas and the actions needed to make the situation safe.

Don't Delay – Make this Call When a Gas Odor or Related Problem is Reported

Fire, law enforcement, or 911 dispatchers should immediately call the Ameren Illinois Fire and Police Hotline at 1.800.767.8048.

Your assistance and support in implementing this procedure throughout your organization is critical to ensuring an effective, consistent response if a gas emergency should occur. Our average response time to natural gas leaks is less than 23 minutes.

Natural Gas Safety Training

Ameren Illinois also offers a natural gas first responder safety training program free of charge. Our Natural Gas Safety training qualifies for two Continuing Education Units (CEUs). Use the following website AmerenIllinois.com/Presentations to request a safety training session or a presentation. Contact Jacob Dukett, Supervisor, Public Awareness, at 1.217.358.6575 or JDukett@ameren.com.

Online Gas Pipeline Information

A national pipeline mapping website is also available to you at www.npms.phmsa.dot.gov. This website allows emergency responders to register to receive information on the location of pipelines that run through their response area and the type of products transported in those pipelines.

New JULIE Number

Please note that the nationwide "Call Before You Dig" number (JULIE) is now 811. For more information, visit Illinois1Call.com.

Thank you for your support of safety. Please contact us if we can be of further assistance or visit our website at AmerenIllinois.com.

Sincerely,

JACOB DUKETT
Supervisor, Public Awareness
Gas Compliance
C 217.358.6575
E JDukett@ameren.com

OT 8005

FIRST RESPONDERS **NATURAL GAS EMERGENCY PROCEDURE**

This procedure identifies the actions that should be taken by fire, law enforcement, 911 dispatchers and other emergency response personnel when a gas odor or other natural gas-related problem is reported.

1. **CALL 1.800.767.8048 to report all natural gas odors or other natural gas-related problems to Ameren Illinois.**
2. Emergency response personnel should respond to the call. Upon notification, Ameren Illinois will also dispatch an employee to the site as soon as possible.
3. If the gas odor is strong indoors, immediately evacuate the building. Do not operate any electrical switches and leave the door open after exiting as the strike plate may cause a spark.
4. If the gas odor or apparent damage to gas facilities is outdoors, barricade the street or area, and keep all people at the site a safe distance away. Remove any sewer manhole covers near the area if the odor appears to be originating below ground.
5. Check surrounding buildings for potential gas migration and evacuate as necessary. Continue to monitor gas readings as conditions may change or migration expand. Keep Ameren Illinois updated as conditions warrant.
6. When a structural fire occurs around natural gas service, you can turn off the gas service at the meter; however, do not restore gas service. In these situations, Ameren Illinois will inspect the premises and determine if service can be safely restored. In all cases where a fire is suspected to have been fueled by natural gas, Ameren Illinois must be called immediately.

To report a natural gas or electrical emergency, call Ameren Illinois at:

1.800.755.5000 *(Public Number)*

1.800.767.8048* *(Emergency Response Personnel Only)*

We respond to emergency calls 24 hours a day, seven days a week.

**Note: This phone number is intended specifically for first responders and should not be distributed to the general public. With the merger of AmerenCIPS, AmerenCILCO and AmerenIP to form Ameren Illinois, we have consolidated the previous numbers for first responders, so the number you need to call may have changed. Please be sure to update your records. Older numbers will eventually be phased out.*

OT 8005

Appendix B - Sample Operator Page



Web site: amerenillinois.com
 Emergency Number: 800-755-5000

IMPORTANT INFORMATION ABOUT GAS PIPELINES IN YOUR AREA

About Ameren Illinois

Ameren Illinois is a regulated electric and gas delivery company based in Collinsville, Illinois. Ameren Illinois serves approximately 840,000 gas customers, making us the state's third largest distributor of natural gas. We provide natural gas service in more than 550 communities in central and southern Illinois. Our extensive delivery system includes 18,000 miles of natural gas transmission and distribution pipelines and 12 underground natural gas storage fields.

What does Ameren Illinois do if a gas leak occurs?

To prepare for the event of a natural gas leak, Ameren Illinois regularly communicates, plans and trains with local emergency responders. The company offers free workshops for fire and police personnel, paramedics, public works employees and others whose jobs may involve working around natural gas.

Ameren Illinois personnel and emergency responders are trained to protect life, property and facilities in the case of an emergency.

Upon the notification of an incident or leak, Ameren Illinois will immediately dispatch qualified personnel to respond to the emergency. We respond within the hour – around the clock – with an average response time of 23 minutes.

In the event of an emergency, Ameren Illinois will take steps to minimize the amount of leaking gas and isolate the pipeline emergency.

Maintaining pipeline safety and integrity

Ameren Illinois invests significant time and money to maintain the integrity of our pipeline systems. We also follow detailed operating, maintenance and communication plans to ensure the safety of our pipelines.

Our highly trained employees monitor our system 24 hours a day. They then notify field personnel if an abnormal condition is detected.

We perform regular maintenance to ensure proper pressure control, odorization and reliable service. In addition, all new gas service installations include excess flow valves to stop the flow of gas in the event a service line is hit or ruptures.

Our employees receive extensive, ongoing training to ensure the safe transportation of natural gas. Our workers must pass rigorous testing and follow the National Fuel Gas Code, the Ameren Operations and Maintenance Manual and Ameren Gas Standards.

In accordance with federal regulations, Ameren Illinois has developed an Integrity Management Program, a supplemental hazard assessment and prevention program. This program deals with "high consequence areas" near pipelines, such as highly populated areas and difficult-to-evacuate facilities.

For Additional Information

For a list of companies with pipelines in your area and their contact information, or to apply for PIMMA access, go to www.npms.phmsa.dot.gov/.

For additional information about Ameren Illinois, go to amerenillinois.com or call **1.800.755.5000**. If you are interested in having a representative from Ameren Illinois meet with you at your location please contact us.

PRODUCTS TRANSPORTED

PRODUCTS TRANSPORTED IN YOUR AREA

PRODUCT	LEAK TYPE	VAPORS
NATURAL GAS	Gas	Lighter than air and will generally rise and dissipate. May gather in a confined space and travel to a source of ignition.
HEALTH HAZARDS	Will be easily ignited by heat, sparks or flames and will form explosive mixtures with air. Vapors may cause dizziness or asphyxiation without warning and may be toxic if inhaled at high concentrations. Contact with gas or liquefied gas may cause burns, severe injury and/or frostbite.	

PIPELINE MARKERS



SYSTEM MAP

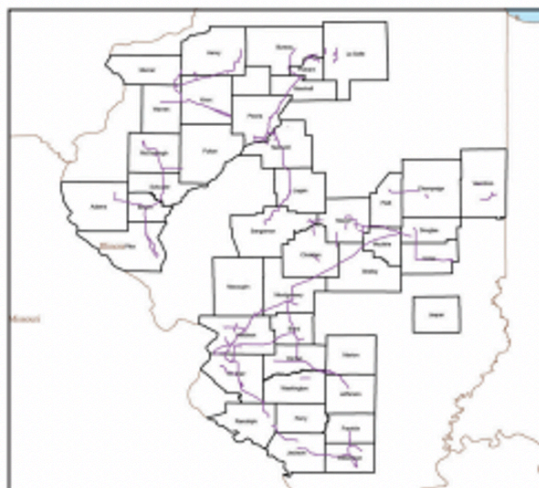

AMRNIL

INFORMACIÓN IMPORTANTE ACERCA DE LAS LÍNEAS DE TUBERÍAS DE GAS EN SU ÁREA

Acerca de la compañía Ameren Illinois

Ameren Illinois es una compañía regulada de electricidad y de gas basada en Collinsville, Illinois. Ameren Illinois le da servicio de gas a aproximadamente 840,000 clientes, convirtiéndonos en el tercer distribuidor de gas más grande del estado. Proveemos servicio de gas natural en más de 550 comunidades en la parte central y del sur de Illinois. Nuestro extenso sistema de entrega incluye 18,000 millas de líneas de tuberías de transmisión y distribución de gas natural y 12 campos subterráneos de almacenamiento de gas natural.

¿Qué hace Ameren Illinois si ocurre una fuga?

Para estar preparados en caso de una fuga, Ameren Illinois se comunica, planea y entrena regularmente con los respondedores locales de emergencias. La compañía ofrece talleres gratuitos para el personal de los bomberos y de la policía, los paramédicos, empleados de servicios de utilidades públicos y otras personas cuyos trabajos pueda que envuelvan trabajar alrededor de gas natural.

El personal de Ameren Illinois y los respondedores de emergencias están entrenados para proteger vidas, propiedades e instalaciones en caso de una emergencia.

Al ser notificados de un incidente o de una fuga, Ameren Illinois enviará inmediatamente a un personal cualificado para responder a la emergencia. Nosotros respondemos en el plazo de una hora – día y noche – con un promedio de tiempo de respuesta de 23 minutos.

En caso de una emergencia, Ameren Illinois tomará los pasos necesarios para minimizar la cantidad de gas que se esté escapando y aislar la emergencia en la línea de tuberías.

Manteniendo la seguridad y la integridad de las líneas de tuberías

La compañía Ameren Illinois invierte una cantidad considerable de tiempo y capital para mantener la calidad e integridad de sus sistemas de líneas de tubería. También seguimos planes detallados de operaciones, mantenimiento y de comunicación para asegurar la seguridad de nuestras líneas de tuberías.

Nuestros empleados altamente entrenados monitorean nuestro sistema las 24 horas del día. Ellos le notifican al personal de campo si se detecta una condición anormal.

Nosotros realizamos un mantenimiento constante para asegurar un control de presión apropiado, odorización y un servicio confiable. Además, todas las instalaciones de servicios de gas nuevas incluyen válvulas de exceso de flujo para detener el flujo de gas en caso que una línea de servicio sea golpeada o se rompa.

Nuestros empleados reciben un entrenamiento extensivo y constante para garantizar la transportación segura del gas natural. Nuestros trabajadores deben pasar una prueba rigurosa y seguir los Códigos Nacionales de Combustible de Gas, el Manual de Operaciones y Mantenimiento de Ameren y los Estándares de Gas de Ameren.

En conformidad con las regulaciones federales, Ameren Illinois ha desarrollado un Programa de Manejo de Integridad, el cual es un programa suplementario de evaluación y prevención de peligros. Este programa aborda las "áreas de alta consecuencia" que se encuentran cerca de las líneas de tuberías, tales como las áreas altamente pobladas y las instalaciones que son difíciles de evacuar.

Para obtener información adicional

Para una lista de las compañías que tienen líneas de tuberías en su área junto con la información de contacto, o para aplicar para acceso al PIMMA, visite www.npms.phmsa.dot.gov/.

Para obtener información adicional acerca de Ameren Illinois, visite amerenillinois.com, o llame al **1.800.755.5000**. Si usted está interesado en que un representante de Ameren Illinois lo visite en su ubicación

PRODUCTOS TRANSPORTADOS

PRODUCTOS TRANSPORTADOS EN SU AREA

PRODUCTO	TIPO DE FUGA	VAPORES
GAS NATURAL	Gas	Es más liviano que el aire y generalmente se eleva y se disipa. Se puede acumular en espacios confinados y viajar hasta fuentes de encendido.
PELIGROS PARA LA SALUD	Son muy fáciles de incendiarse con el calor, chispas o llamas y forman una mezcla explosiva con el aire. Los vapores pueden causar mareos o asfixia sin dar ningún aviso y pueden ser tóxicos si se inhalan en concentraciones grandes. El contacto con gas o con gas líquido puede causar quemaduras, heridas graves y/o congelamiento.	

MARCADORES DE DUCTO

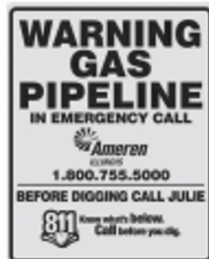

Sitio web: amerenillinois.com
Número de Emergencia: 800-755-5000

MAPA DE SISTEMA

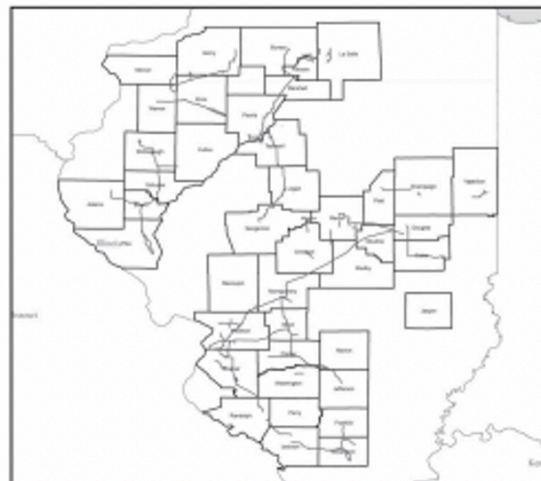

PUBLIC EDUCATION

October 1, 2021

PUBL 3 Forms and Reference Materials

Click on the links below to open the documents.

Ameren Public Awareness Program is also available on the Public Awareness SharePoint site.

References

1. [Ameren Public Awareness Program 2019](#)
2. [Emergency Responder Brochure \(Ameren Illinois Face to Face Distribution\)](#)
3. [Natural Gas Safety Flyer, Stock Code 37 22 287 \(Ameren Illinois Annual Mailing\), July 2020](#)
4. [Natural Gas Scratch n Sniff Insert](#)

Paradigm Mailing Brochures

5. [Affected Public Along Transmission Pipeline](#) (Odd Years)
6. [Excavators Along Transmission Pipelines](#) (Odd Years)
7. [Farmers Along Transmission Pipelines](#) (Odd Years)
8. [Schools Along Transmission Pipelines](#) (Odd Years)
9. [Emergency Responders Along Transmission Pipelines and in Our Service Areas](#) (Annual)
10. [Public Officials Along Transmission Pipelines and in Our Service Areas](#) (Even Years)

Culver Mailing Brochures

11. [Excavators in Our Service Areas](#) (Annual)
12. [Schools in Our Service Areas](#) (Annual)
13. [Ameren Illinois An Important Safety Message About Hidden Hazards](#) (Annual)
14. [Contractor Electrical and Natural Gas Safety Information, 2020](#)(Annual)
15. [Overhead Power Line Safety Information, 2020](#)(Annual)
16. [AIC Educational Material Letter for National Energy Foundation](#) (Annual)

End of Section.

Document Rescission

PUBL 3 Public Education: Forms and Reference Materials, October 1, 2020.

Revision Notes

Location of Changes	Summary of Changes
Reference Materials	Added: Natural Gas Scratch n Sniff Insert Updated:

UNCONTROLLED IF PRINTED

Natural Gas Safety Flyer, July, 2020.
Ameren Illinois Important Safety Message About Hidden Hazards.
Contractor Electrical and Natural Gas Safety Information, 2020.
Overhead Power Line Safety Information, 2020.

PURG-Purging

PURGING

May 15, 2022

PURG 0 Table of Contents

PURG 1 Purging: Requirements

Section 1.0 Purpose

Section 2.0 Scope

Section 3.0 Target Audience

Section 4.0 General

Section 5.0 Service Lines

Section 6.0 Transmission Lines and High-Pressure Distribution Mains

Section 7.0 Abandonment

Operator Qualification (OQ)

Appendices

Appendix A - Purge Plan and Documentation Requirements for Abandonment
Table

Appendix B - Purge Stamp

Compliance Requirements

Reference Documents

Document Rescission

PURG 2 Purging: Methods

Section 1.0 Purpose

Section 2.0 Scope

Section 3.0 Target Audience

Section 4.0 Safety

Section 5.0 Purging of Air with Gas

Section 6.0 Purging of Gas with Air During Abandonment

Section 7.0 Using an Inert Gas Slug when Purging

Section 8.0 Required Minimum Inlet Pressures

Section 9.0 Vacuum Purge/Air Mover

Section 10.0 Purge Velocity

Section 11.0 Monitoring Purge

Section 12.0 Venting of Gas

UNCONTROLLED IF PRINTED

- Section 13.0 Time to Vent Pipeline
- Section 14.0 Flaring of Gas
- Section 15.0 Use of Compression System
- Operator Qualification (OQ)
- Compliance Requirements
- Reference Documents
- Document Rescission

PURG 3 Purging: Forms and Reference Materials

- Forms
- Reference Materials
- Document Rescission

End Table of Contents.

Document Rescission

PURG 0 Purging: Table of Contents, December 15, 2021

Revision Notes

Location of Changes	Summary of Changes
PURG 2.0	Changed from PURG 2
PURG 2.0 – Section 15	Spelling correction: Compression

PURGING

October 1, 2022

PURG 1 Requirements**1.0 Purpose**

This document specifies requirements for purging gas mains and pipelines, including for abandonment purposes, and the venting of gas.

All requirements in this document are in accordance with 49 CFR §§ 192.629 and 192.727.

2.0 Scope

This document addresses the following:

[3.0 Target Audience](#)[4.0 General](#)[5.0 Service Lines](#)[6.0 Transmission Lines and High-Pressure Distribution Mains](#)[7.0 Abandonment](#)

Appendices

[Appendix A - Purge Plan and Documentation Requirements for Abandonment Table](#)[Appendix B - Purge Stamp](#)**3.0 Target Audience**

- Gas Engineering
- Gas Tech Engineering (GTE)
- Gas Distribution Design Specialist
- Gas Field Personnel
- Gas Supervisors
- Gas Construction Services Personnel
- Gas Tech Services (GTS) Supervisors
- Gas Tech Service (GTS) Personnel
- Gas Storage Engineer (GSE)
- Gas Storage Field Supervisors
- Gas Storage Field Operators
- Gas Control

4.0 General

4.1 Gas Engineering, Gas Tech Engineering (GTE) or Gas Storage Engineering (GSE) will provide detailed purging plans developed in accordance with AGA Purging Principles and Practices prior to blowdown or purging operations for:

4.1.1 Transmission mains 100 feet and longer in length

4.1.2 High-pressure distribution mains 100 feet and longer in length

4.1.3 Service lines 2 inches and larger, that meet the following requirements:

1. 100 feet or longer in length

AND

2. Operating at more than 100 psig.

4.1.4 Project utilizing an air mover.

UNCONTROLLED IF PRINTED

- 4.1.5 Joint abandonment of distribution mains and services.
- 4.2 When planning projects, consider options to eliminate hazards and minimize the release of natural gas. See [MAIN 1 Section 18.0](#) Design Considerations.
- 4.3 Prior to the purge, when a large volume of gas is to be released to atmosphere:
 - 4.3.1 If the system to be purged is remotely monitored, include Gas Control for planning and scheduling.
 - 4.3.2 Notify public officials, such as police or fire departments.
 - 4.3.3 Monitor weather for air inversions and wind conditions to ensure that release of gas does not migrate towards:
 - 1. Schools
 - 2. Businesses
 - 3. Homes
 - 4. Highways, etc.
 - 4.3.4 Notify AIC Dispatch Center.
- 4.4 During purging, keep blowoff area clear to avoid property damage or personal injury.

Liquids or debris can be ejected into the blowoff gas stream and land downwind.

Be aware of the wind direction/speed and the presence of potential sources of ignition, especially overhead power lines.

- 4.5 For purge monitoring, use a Combustible Gas Indicator (CGI) at or near outlet of purge and at or near top of pipe being purged.
- 4.6 If purge pipe is used, the pipe shall be:
 - 4.6.1 Made of metal.
 - 4.6.2 Of sufficient length to prevent hazards to:
 - 1. The public
 - 2. PersonnelOR
 - 3. Adjacent property.
 - 4.6.3 Grounded to prevent static charge.
- 4.7 Verify that gauges used to monitor pressure during purging are operating properly.
- 4.8 Purging operations are not considered working in a gaseous environment.

5.0 Service Lines

- 5.1 Service lines 2 inches and larger and 500 feet or longer in length are to be purged in the same manner as mains. See [PURG 2, Subsection 7.1](#).

- 5.2 In lieu of a purge pipe, service lines smaller than 2 inch and 500 feet or shorter in length can be vented through the service riser.

6.0 Transmission Lines and High-Pressure Distribution Mains

- 6.1 Coordinate with Gas Control when transmission lines or HP distribution mains are either permanently or temporarily taken out of service or reduced in pressure. See [ABND 1, Section 4.0](#), Pre-Abandonment Planning.
- 6.2 Release of large volumes of gas into atmosphere, when practical, shall be minimized by transferring (drawdown) as much gas as possible from the pipeline to be purged to other parts of the system.
- 6.3 Consider noise levels and potential gas leak calls during purging or blowing down transmission lines or HP distribution mains.

Use of masking agent may be a solution to mitigate potential gas leak calls.

- 6.4 Turn blow-down valves fully open as quickly as possible to minimize possible erosion to a blow-down valve during high-flow situations.
- 6.5 If flaring is used, GTE will include procedures in the purging plan. See [PURG 2, Section 14.0](#), Flaring of Gas.

7.0 Abandonment

- 7.1 The table shown in [Appendix A](#) lists purge plan and documentation requirements for abandonment.
- 7.2 [Appendix B](#) shows the Purge Stamp (Basic) and Purge Form (Field) which are used to document completion of purging for abandonment.
- 7.2.1 The Purge Stamp (Basic), Form 01, will be on the engineered plans which involve abandoning gas facilities primarily coming from the Design Centers. See [PURG 3](#) Form 01.
- 7.2.2 The Purge Form (Field), Form 02, is a standalone form that is to be printed and used to document purging of abandoned gas facilities on any project which does not contain a Purge Stamp (Basic). Typically, these projects will be associated with non-engineered projects such as a minor relocation or replacement project, maintenance or leak repairs. See [PURG 3](#) Form 02.
- 7.3 In lieu of Purge Stamp, the Construction Plan purge plan can contain purge point table with sign-off for each point.
- 7.4 Service lines purged together with a main or transmission line as a unit for abandonment require a purge plan.

End of Instructions.

Operator Qualification (OQ) Required?

YES

0301: Manually Opening and Closing Valves

0311: Adjust and Monitor Flow or Pressure - Manual Valve Operation

UNCONTROLLED IF PRINTED

- 1371: Operate Gas Pipeline – System Control Center Operations
- 1381: Operate Gas Pipeline – Local Facility Remote Control Operations
- 1631: Launching and/or Receiving Internal Devices (Pigs) with a temporary launcher and/or receiver for Lines Out of Service
- 1641: Launching and/or Receiving Internal Devices (Pigs) for Lines In-Service
- 1651: Purge - Flammable or Inert Gas
- A002: Abandonment

Appendices

[Appendix A - Purge Plan and Documentation Requirements for Abandonment Table](#)

[Appendix B - Purge Stamp](#)

Attachments

NONE.

Compliance Requirements

- 49 CFR §192.629 Purging of pipelines.
- 49 CFR §192.727 Abandonment and deactivation of facilities.

Reference Documents

[ABND 1 Abandonment of Facilities: Requirements](#)

[ABND 2.1 Abandonment of Gas Facilities](#)

AGA Purging Principles and Practices

Document Rescission

PURG 1 Purging: Requirements, December 15, 2021

Revision Notes

Location of Changes	Summary of Changes
Subsection 4.1 – Operations requiring a Purge Plan	Added Paragraph 4.1.5 – Joint abandonment of distribution mains and services.
Subsection 4.8 – Purging operations	Terminology update – working in gaseous environment replaced working in blowing gas.
Subsection 6.2 – Release of large volume of gas	Added "drawdown" as a method for transferring gas from pipeline being purged to other parts of the system.

Appendix A - Purge Plan and Documentation Requirements for Abandonment Table

A-1. Purge Plan and Documentation Requirements for Abandonment Table

Operating Pressure	Facility Type	Size	Length	Purge Plan Required?	Document Purge was Completed?	
100 PSIG or Less	Service Line	Less than 2"	Less than 500 ft	No	Not applicable due to small volume of gas	
			500 ft or Greater	No	Complete purge stamp	
		2" and Larger	All	No	Complete purge stamp	
	Distribution Main	All	All	No	Complete purge stamp	
	Air mover utilized to purge			All	Yes	Complete purge stamp
	Joint Abandonment of Distribution Main and Services (ABND 1 Section 5.0)			All	Yes	Complete purge stamp
Greater than 100 PSIG	Service Line	Less than 2"	Less than 500 ft	No	Not applicable due to small volume of gas	
			500 ft or Greater	No	Complete purge stamp	
		2" and Larger	Less than 100 ft	No	Complete purge stamp	
			100 ft or More	YES	Complete purge stamp	
	Distribution Main OR Transmission Line	All	Less than 100 ft	No	Complete purge stamp	
			100 ft or More	YES	Complete purge stamp	
	Air mover utilized to purge			All	YES	Complete purge stamp
	Joint Abandonment of Transmission Line or HP Distribution Main and Services (ABND 1 Section 5.0)			All	YES	Complete purge stamp

Appendix B - Purge Stamp

A. See Figure 1 for an example of the basic Purge Stamp shown in [PURG 3](#), Form 1.

[\(View/download PDF version.\)](#)

Were Facilities successfully Purged of Gas?
 (REQUIRED for all retirements of Main) See PURG 1
 (Not required for services < 2" Dia. UNLESS > than 500 ft. length)

Choose one:

YES _____
 Completed By

N/A

Figure 1: Purge Stamp (Basic)

B. See Figure 2 for an example of the Purge Form (Field) shown in [PURG 3](#) Form 2.

[\(View/download PDF version.\)](#)

Purge Form (Field)

Job Number: _____

Operating Center: _____

Employee Number: _____

Were Facilities successfully Purged of Gas?
(REQUIRED for all retirements of Main) See PURG 1
(Not required for services < 2" Dia. UNLESS > than 500 ft. length)

Choose one:

YES _____
Completed By

N/A

Figure 2: Purge Form (Field)

PURGING

April 1, 2023

PURG 2 Methods

1.0 Purpose

This document provides procedures for the safe release of gas into the atmosphere in a controlled manner when either voiding a pipeline of natural gas or introducing natural gas into a pipeline. These include various methods for purging and venting of gas.

All procedures are in accordance with 49 CFR §§ 192.629 and 192.727.

2.0 Scope

This document addresses the following:

[3.0 Target Audience](#)[4.0 Safety](#)[5.0 Purging of Air with Gas](#)[6.0 Purging of Gas with Air During Abandonment](#)[7.0 Using an Inert Gas Slug when Purging](#)[8.0 Required Minimum Inlet Pressures](#)[9.0 Vacuum Purge/Air Mover](#)[10.0 Purge Velocity](#)[11.0 Monitoring Purge](#)[12.0 Venting of Gas](#)[13.0 Time to Vent Pipeline](#)[14.0 Flaring of Gas](#)[15.0 Use of Compression System](#)**3.0 Target Audience**

- Gas Engineering
- Gas Tech Engineering (GTE)
- Gas Distribution Design Specialist
- Gas Field Personnel
- Gas Supervisors
- Gas Construction Services Personnel
- Gas Tech Services (GTS) Supervisors
- Gas Tech Services (GTS) Personnel
- Gas Storage Engineer (GSE)
- Gas Storage Field Supervisors
- Gas Storage Field Operators

4.0 Safety

Purging and venting gas are dangerous operations that can result in serious consequences, such as property damage, injury or death, if all instructions and warnings are not followed.

UNCONTROLLED IF PRINTED

- 4.1 Ensure that contents of pipeline vented into atmosphere are at sufficient distance above grade to allow released gas to diffuse into air without causing hazards to personnel, property or the public. In general, this requires a vent pipe long enough to carry the gases above the heads of the workers on equipment located outdoors.
- 4.2 Pay special attention to wind direction and speed with consideration to potential sources of ignition, especially overhead power lines.
- 4.3 Ensure that fire extinguisher is on the jobsite when a main or service line is being purged.
- 4.4 Remove all potential sources of ignition, such as smoking, open flames or unrated electrical devices.

5.0 Purging of Air with Gas

- 5.1 Pipelines being purged of air with gas shall have gas released into one end of the line in a moderately rapid and continuous flow. See [Table 3](#) and [Table 4](#) for minimum inlet pressures to ensure adequate flow.

If the amount of gas available is insufficient to prevent hazardous mixture of gas and air, a slug of inert gas shall be injected in the line before gas. See [Section 7.0](#).

- 5.2 Purge is complete when CGI readings reach 90% gas-in-air or greater and the smell of gas is present if gas is odorized.
 - 5.2.1 Alternatively, purging may also be considered complete at 90% gas-in-air when:
 1. Engineering has prepared a pipeline conditioning (pickling) plan.
 2. Pipeline is not required to be odorized and does not have odorized gas.
- 5.3 Service lines 2 inches and smaller AND equipped with Excess Flow Valves (EFV): Slowly open the meter valve to purge air until gas is detected at the outlet, then close the meter valve.

6.0 Purging of Gas with Air During Abandonment

- 6.1 Check for zero pressure at risers used as a purge point, at the site of injection, before introducing the purge medium.
- 6.2 Pipelines being purged of gas with air shall have air released into one end of the line in a moderately rapid and continuous flow.
 - 6.2.1 For a disconnected line do not exceed the established MAOP of the line.
 - 6.2.2 When control fittings are used to shut-off flow to the section being purged, do not exceed the Operating Pressure at time of the Stop. Adhere to manufacturer's published operating pressure limits of the control fittings and stopping equipment.

Pipeline liquids and solids are typically combustible and may remain combustible after purging. Spontaneous ignition can occur if adequate air supply is available to items that may con-

tain pipeline liquids and solids, such as filter and separator elements.

- 6.3 If the amount of air available is insufficient to prevent hazardous mixture of gas and air, a slug of inert gas shall be injected in the line before air. See [Section 7.0](#).
- 6.4 Purge until a combustible mixture is no longer present, 2% LEL or less, measured with a CGI. Keep in mind that purging only removes gaseous material.
- 6.5 Seal ends of abandoned pipelines after purging. Refer to [ABND 2.1, Section 5.0](#), Transmission Lines and Distribution Mains and [ABND 2.1, Section 6.0](#), Services.

7.0 Using an Inert Gas Slug when Purging

- 7.1 When purging mains 8 inches or larger, 100 feet or longer in length AND **operates** at more than 100 psig, separate air/gas interface with an injected slug of inert gas. Connect the inert gas hose to a fitting for injection.
- 7.2 The slug of inert gas shall be long enough to prevent air/gas from mixing during the purge. Determine inert gas volume by the length and diameter of the pipe being purged. See Table 1.

Table 1: Volume of Inert Gas Slug (cu ft)

Pipe Size (inches)	Length of Pipe (feet)						
	500	1,000	2,000	5,000	10,000	20,000	50,000
4	40	40	50	55	60	80	100
6	60	60	60	80	100	140	200
8	140	140	160	180	240	320	400
10	260	280	300	360	460	560	700
12	360	400	440	500	540	580	740
16	700	800	900	1,060	1,140	1,220	1,320
20	1,080	1,200	1,360	1,540	1,660	1,780	1,960
22	1,460	1,720	1,920	2,200	2,400	2,600	2,800
24	2,600	3,000	3,400	4,000	4,400	4,600	5,200

Cubic Feet - includes 100% factor of safety.

To determine the number of large cylinders, divide the volume by 200.

- 7.3 If practical, insert a poly pig so the inert gas can be admitted ahead of the pig and the air or natural gas admitted behind the pig.

If a poly pig is used, the volume of nitrogen/carbon dioxide can be reduced by 50%.

- 7.4 After the inert gas has been injected into the pipeline, begin flow of natural gas or air as soon as practical.
 - 7.4.1 Delays in purging after injection of inert gas may make the slug ineffective.

7.4.2 If there is a delay between injection of inert gas and air/gas greater than 3 minutes, inject a new slug.

7.4.3 If a pipeline is 100% filled with inert gas, time lag is no longer a factor.

7.5 Natural gas or air shall continue to flow until purge is complete.

7.6 Seal ends of abandoned pipelines after purging. Refer to [ABND 2.1](#).

8.0 Required Minimum Inlet Pressures

8.1 Table 3 and Table 4 provide minimum inlet pressure required to maintain minimum flow during purging. Do not exceed MAOP. Adhere to manufacturer's published operating pressure limits and practices, when using control fittings.

8.2 Consult with Gas Tech Engineering (GTE) for pipe sizes not shown in Table 3 or Table 4.

Table 3: Minimum Inlet Pressure Required to Maintain Minimum Flow During Purge

Length of Pipeline (feet)	Minimum Inlet Pressure (psig) With:				
	2" Blowdown Valve			4" Blowdown Valve	
	Line Size (inches)			Line Size (inches)	
	2	4	6	6	8
500	3	3	5	4	3
1500	4	6	12	4	4
2500	6	8	16	6	5
4000	8	11	19	7	7

Table 4: Minimum Inlet Pressure Required to Maintain Minimum Flow During Purge

Length of Pipeline (miles)	Minimum Inlet Pressure (psig) With:										
	2" Blowdown Valve		4" Blowdown Valve				6" Blowdown Valve				
	Line Size (inches)		Line Size (inches)				Line Size (inches)				
	4	6	6	8	10	12	12	16	20	22	24
1	14	22	8	8	11	18	6	11	21	28	36
2	20	25	12	11	13	20	8	12	22	28	36
3	25	28	16	13	15	21	10	13	23	29	36
4	29	30	19	16	17	22	11	14	23	29	37
5	33	32	22	18	18	23	13	15	24	30	37
6	37	35	24	20	20	24	14	16	25	30	37
7	40	37	27	22	21	25	16	17	25	31	38
8	43	39	29	24	23	26	17	18	26	31	38
9	46	41	32	26	24	27	18	19	26	31	39
10	49	43	34	28	25	28	20	20	27	32	39

9.0 Vacuum Purge/Air Mover

9.1 An alternative to purging gas from a line is to use a vacuum purge to extract gas from the system, replacing gas with fresh air. See [PURG 3 for MBW Vapor Extraction Unit \(VEU\) Manual](#).

9.1.1 Vacuum/air mover is typically connected to one or more locations using vacuum to extract the gas from the system while opening other points of the system to allow air intake from atmosphere.

9.1.2 Air movers displace gas with large volumes of fresh air, connected to one point of the system with another point downstream opened to atmosphere.

9.2 When air movers are used for pipeline purging, Gas Engineering, GTE or Gas Storage Engineer will provide a purging plan, using AGA's Purging Principles and Practices as general basis for the plan.

It is critical that a good seal exists between the air mover and purge stack for proper operation.

9.3 Ground clamp or wire from air mover to ground is required to dissipate static electricity buildup.

9.4 The type of valve that air movers are mounted on can significantly reduce air flow, such as plug valves that cause 40% reduction in flow. GTE will factor this into the purge plan.

9.5 Typically, before an air mover/vacuum purge operation, a slug of inert gas is injected through a closed loop to separate air from gas. See [Table 1](#) in [Section 7.2](#).

9.6 Once the air mover is started, ensure fresh air is being drawn into the main (i.e. verify vacuum is established at location where air is to be introduced).

Prior to cutting with a torch or using a grinder, reduce air mover flow rate to minimize spark travel.

9.7 When a CGI indicates a combustible mixture is no longer present and 2% LEL or less exists in the pipeline at the site of the first "Cold" cut, then the cutting operations can begin (wheel cutting, guillotine, etc.).

9.7.1 After the initial cut and air is introduced via vacuum, a torch can be used for cutting.

10.0 Purge Velocity

10.1 To minimize mixing gas and air, the velocity of the purge shall be high enough to create a turbulent flow.

10.2 As velocity increases, turbulence increases, which reduces risk of creating a long section of combustible air-gas mixture.

11.0 Monitoring Purge

11.1 Install pressure gauges of the appropriate pressure range at the inlet and outlet of the purge to continuously monitor the pressure to assure adequate flow.

11.2 Continuously monitor inlet valves and maintain constant communication, radio or telephone, with other areas of the purge operations to control and limit purge velocity.

11.3 Maintain a moderately rapid and continuous flow by utilizing the control valves in purge stack.

11.4 Purge pipeline completely from one end to the other especially when purging air with gas.

11.5 Monitor pressures at defined points using gauges during purging to ensure the correct pressures are maintained.

12.0 Venting of Gas

When gas is vented into atmosphere, all potential sources of ignition (such as smoking, open flames, unrated electrical devices and overhead power lines) shall be removed from the area or de-energized.

12.1 Contents of pipeline vented into atmosphere shall be at sufficient distance above grade to allow released gas to diffuse into air without causing hazards to personnel, property or the public. In general, this requires a vent pipe long enough to carry the gases above the heads of the workers on equipment located outdoors.

12.2 Refer to [ACIG 2](#) Work Area Protection for placement of VEU or Compression System, such as ZEVAC, away from ignition sources.

12.3 Shut off all vehicles and unrated equipment in the area where gas is released.

12.4 The extension stack shall be metallic and grounded to draw off static electrical charges. See Section 12.1 for stack requirements.

12.5 Prior to welding or cutting, use a gas detection instrument to thoroughly check for presence of a combustible gas mixture. See [ACIG 2](#).

13.0 Time to Vent Pipeline

13.1 CGI shall be used as the final determination method. See Table 5 below.

Table 5: Time Required to Vent (minutes/mile)

Line Pressure (psig)	Time Required to Vent (minutes/mile) With:								
	2-inch Blowdown Valve		4-inch Blowdown Valve				6-inch Blowdown Valve		
	Line Size (inches)		Line Size (inches)				Line Size (inches)		
	4	6	6	8	10	12	12	14	16
100	1.03	2.32	0.58	1.03	1.61	2.32	1.03	1.41	1.84
200	1.32	2.97	0.74	1.32	2.07	2.97	1.32	1.80	2.35
300	1.50	3.37	0.84	1.50	2.34	3.37	1.50	2.04	2.66
400	1.63	3.66	0.91	1.63	2.54	3.66	1.63	2.21	2.89
500	1.73	3.88	0.97	1.73	2.70	3.88	1.73	2.35	3.07
600	1.81	4.07	1.02	1.81	2.82	4.07	1.81	2.46	3.21
700	1.88	4.22	1.06	1.88	2.93	4.22	1.88	2.56	3.34
800	1.94	4.36	1.09	1.94	3.03	4.36	1.94	2.64	3.44
900	1.99	4.48	1.12	1.99	3.11	4.48	1.99	2.71	3.54
1,000	2.04	4.59	1.15	2.04	3.19	4.59	2.04	2.78	3.62
1,100	2.08	4.69	1.17	2.08	3.25	4.69	2.08	2.83	3.70
1,200	2.12	4.77	1.19	2.12	3.32	4.77	2.12	2.89	3.77

13.2 Calculation Method

$$T = \left[\frac{D_L^2 \times L}{45,789 D_B^2} \right] \ln \frac{P}{12.2}$$

T=Time,minutes

D_L=Internal Diameter of Line Pipe,inches

L=Length of Line Segment,feet

D_B=Internal Diameter of Blow Down,inches

P=Initial Pressure,psia

13.2.1 *Example:* Calculate the time required to vent a 12" gas pipeline, 5 miles long, under 400 psig pressure, through a 4" diameter riser.

T=Time,minutes

D_L=12 inches

L=5 miles ×5,280 feet/mile=26,400 feet

D_B=4 inches

P=400 psig+14.4 psi atmospheric pressure=414.4 psia

$$T = \left[\frac{(12 \text{ in})^2 \times 26,400 \text{ ft}}{45,789 (4 \text{ in})^2} \right] \ln \frac{414.4 \text{ psia}}{12.2} = 18.3 \text{ minutes}$$

14.0 Flaring of Gas

14.1 An alternative to venting gas into the open air is to burn the gas through a flare.

14.2 Prior to flaring gas, a procedure shall be developed outlining:

14.2.1 Volume of flare gas.

14.2.2 Maximum flaring pressure and pressure control method.

14.2.3 Flare ignition and relight system.

14.2.4 Notifying public officials, fire and police authorities.

14.2.5 Open burning permit.

15.0 Use of Compression System

15.1 As determined by engineering, a compression system, such as a ZEVAC system, may be used to reduce the amount of natural gas released to the atmosphere. See **PURG 3 for ZEVAC Manuals**.

15.2 Only rated compressors may be used.

15.3 Prior to compressing gas, engineering shall develop procedures outlining:

15.3.1 Volume of gas.

15.3.2 Expected time for drawdown.

15.3.3 Expected final pressure.

15.3.4 Pressure monitoring plan.

15.3.5 Connection points

End of Instructions.

Operator Qualification (OQ) Required?

YES

0301: Manually Opening and Closing Valves

0311: Adjust and Monitor Flow or Pressure - Manual Valve Operation

1631: Launching and/or Receiving Internal Devices (Pigs) with a temporary launcher and/or receiver for Lines Out of Service

1641: Launching and/or Receiving Internal Devices (Pigs) for Lines In-Service

1651: Purge - Flammable or Inert Gas

A002: Abandonment

Appendices

NONE.

Attachments

NONE.

Compliance Requirements

49 CFR §192.629 Purging of pipelines.

49 CFR §192.727 Abandonment and deactivation of facilities.

Reference Documents

[ABND 1 Abandonment of Facilities: Requirements](#)

[ABND 2.1 Abandonment of Facilities: Abandonment of Gas Facilities](#)

[ACIG 2 Accidental Ignition: Work Area Protection](#)

AGA Purging Principles and Practices

Document Rescission

PURG 2 Purging: Purging Methods, October 1, 2022

Revision Notes

Location of Changes	Summary of Changes
Subsection 7.1 – Using and Inert Gas Plug when Purging	Grammatical – operates replaced operating.
Subsection 9.1= Vacuum Purge/Air Mover	Added – See PURG 3 for MBW Vapor Extraction Unit (VEU) Manuals
Subsection 15.1 – Use of Compression System	Added – See PURG 3 for ZEVAC Manuals

PURGING

April 1, 2023

PURG 3 Forms and Reference Materials

Click on the links below to open the documents.

Forms

1. [Purge Stamp \(Basic\)](#)
2. [Purge Form \(Field\)](#)

Reference Materials

1. [Zevac Operator's Manual](#)
2. [Zevac Operator's Manual - Mini](#)
3. [MBW VEU Manual](#)
4. [iTrans 2 User Manual](#)

End of Section.

Document Rescission

PURG 3 Purging: Forms and Reference Materials, December 15, 2021.

Revision Notes

Location of Changes	Summary of Changes
Reference Materials	Added – Zevac Operator's Manual

QUAL-Quality Assurance Program

QUALITY ASSURANCE PROGRAM

October 1, 2022

QUAL 0 Table of Contents

[QUAL 1 Quality Assurance Program: Requirements](#)

Section 1.0 Purpose
Section 2.0 Scope
Section 3.0 Target Audience
Section 4.0 Objective
Section 5.0 Program
Section 6.0 Quality Assurance Bulletin
Operator Qualification (OQ)
Compliance Requirements
Reference Documents
Document Rescission

[QUAL 4 Quality Assurance Program: Forms and Reference Materials](#)

Forms

1. [General Requirements](#)
2. [Customer Meters and Regulators](#)
3. [Joining](#)
4. [Emergency Valves](#)
5. [Leak Repair](#)
6. [Leak Survey](#)
7. [Pipeline Patrol](#)
8. [Pressure Control](#)
9. [Odorization](#)
10. [Leak Investigation](#)
11. [Corrosion Control](#)
12. [Main O&M](#)
13. [Service O&M](#)
14. [Pressure Testing](#)
15. [Transmission O&M](#)

UNCONTROLLED IF PRINTED

16. [Abnormal Operating Conditions and Emergency Response](#)
17. [Locating](#)
18. [Steel Welding](#)
19. [Excavation and Job Site Protection](#)
20. [NDT Radiographic Inspection](#)

Document Rescission

End Table of Contents.

Document Rescission

QUAL 0 Quality Assurance Program: Table of Contents, October 1, 2022

Revision Notes

Location of Changes	Summary of Changes
Entire Document	Format of document has been changed to match the format of October 2022 Issue.

QUALITY ASSURANCE PROGRAM

October 1, 2022

QUAL 1 Requirements

1.0 Purpose

This section outlines the Ameren Illinois' (AIC) Quality Control and Quality Assessment methods of the Quality Assurance Program.

2.0 Scope

This document addresses the following:

[3.0 Target Audience](#)

[4.0 Objective](#)

[5.0 Program](#)

[6.0 Quality Assurance Bulletin](#)

3.0 Target Audience

- Gas Field Personnel
- Gas Supervisors
- Gas Tech Services (GTS) Personnel
- Gas Tech Services (GTS) Supervisors
- Gas Storage Field Personnel
- Gas Storage Field Supervisors
- Gas Construction Services Personnel
- Gas Construction Service Supervisors
- Gas Quality Assurance Consultants

4.0 Objective

- 4.1 AIC Gas Operations can be improved by reviewing field activities, work processes, and taking corrective action when deficiencies are identified.
- 4.2 The overall objectives of the Quality Assurance Program are to:
- 4.2.1 Observe AIC Gas Field Personnel to ensure compliance with the Gas Operating and Maintenance (O&M) Plan to comply with Federal and State codes and regulations.
 - 4.2.2 Observe work performed with respect to safe work practices.
 - 4.2.3 Review records and documentation for compliance.
 - 4.2.4 Analyze deficiencies for trends and contributing causes to recommend corrective action.
 - 4.2.5 Identify and implement corrective actions when required in order to:
 - 1. Re-direct focus on proper procedures.

UNCONTROLLED IF PRINTED

2. Improve procedures, training, and Operator Qualification testing to improve overall quality.
 3. Promote the addition of new procedures/training to improve quality.
- 4.2.6 Provide coaching to operations as appropriate to assist with change management related to procedure changes and with refresher training on existing procedures.

5.0 Program

- 5.1 The Quality Assurance Program is composed of both Quality Control and Quality Assessment.
- 5.2 Quality Control is comprised of the tasks performed to provide quality products / services. Quality Control includes Apprentice Training, Operator Qualification, and other training/qualifications.
- 5.3 Quality Assessment is comprised of the tasks used to confirm that the AIC Quality Control system is satisfactory. These external tasks include field inspections, records audits, and periodic evaluations of Quality Control processes.
- 5.4 Quality Assessments are performed by Quality Assurance Consultants based on assessment plans. Assessment plans for the Quality Assurance Consultants are generated by the Superintendent of Gas Quality Assurance and include the review of:
- 5.4.1 Construction, Maintenance, and Operations activities being performed by in-house and contractor personnel.
 - 5.4.2 Compliance records and documentation of work performed.
 - 5.4.3 Leak management activities.
 - 5.4.4 As built conditions of facilities.
 - 5.4.5 Support systems and tasks.
- 5.5 Quality Assessments conducted by Quality Assurance Consultants will be documented in LocusView.
- 5.6 Quality Assurance Consultants will verbally communicate the results of the assessment to the local Supervisor.
- 5.6.1 Communication of assessment results with the local Superintendent will take place when deficiencies are discovered during assessments, AND
 - 5.6.2 With Gas Compliance and OQ Staff where deficiencies involve improper performance of a covered task.
- 5.7 The QA Assessment report includes (as applicable)
- 5.7.1 Summary of the assessment.
 - 5.7.2 Safety results observed.
 - 5.7.3 OQ Covered Tasks observed.
 - 5.7.4 Positive results observed.
 - 5.7.5 Deficiencies noted.
 - 5.7.6 Immediate corrective action taken.
 - 5.7.7 Corrective action plans where required.
 - 5.7.8 Other Issues Discussed or Observed (Shared Learning Opportunities).

UNCONTROLLED IF PRINTED

5.7.9 Documents reviewed during the assessment.

5.7.10 Pictures taken during the assessment.

5.7.11 Name of Local Supervisor that the results were communicated to at the end of the assessment.

6.0 Quality Assurance Bulletin

6.1 Significant issues identified that could impact AIC Gas Operations will be shared through a written Quality Assurance Bulletin.

6.2 These bulletins will summarize the issue observed, reference the pertinent section of the Gas O&M Plan or Federal/State regulations, and provide any additional information related to the issue.

6.3 Gas Operations shall discuss this information with their local areas of responsibility.

End of Instructions.

Operator Qualification (OQ) Required?

NONE

Appendices

NONE

Attachments

NONE.

Compliance Requirements

NONE

Reference Documents

NONE

Document Rescission

QUAL 1 Quality Assurance Program: Requirements, May 15, 2022

Revision Notes

Location of Changes	Summary of Changes
Entire Document	Format of document has been changed to match the format of October 2022 Issue.
Former 2. G.	Removed. Construction Inspectors do not perform assessments.

QUALITY ASSURANCE PROGRAM

October 1, 2022

QUAL 4 Forms and Reference Materials

Click on the links below to open the documents.

Forms

1. [General Requirements](#)
2. [Customer Meters and Regulators](#)
3. [Joining](#)
4. [Emergency Valves](#)
5. [Leak Repair](#)
6. [Leak Survey](#)
7. [Pipeline Patrol](#)
8. [Pressure Control](#)
9. [Odorization](#)
10. [Leak Investigation](#)
11. [Corrosion Control](#)
12. [Main O&M](#)
13. [Service O&M](#)
14. [Pressure Testing](#)
15. [Transmission O&M](#)
16. [Abnormal Operating Conditions and Emergency Response](#)
17. [Locating](#)
18. [Steel Welding](#)
19. [Excavation and Job Site Protection](#)
20. [NDT Radiographic Inspection](#)

End of Section.

Document Rescission

QUAL 4 Quality Assurance Program: Forms and Reference Materials, October 1, 2021.

Revision Notes

Location of Changes	Summary of Changes
Entire Document	Format of document has been changed to match the format of October 2022 Issue.

UNCONTROLLED IF PRINTED

REPR-Repairs

REPAIRS

April 1, 2023

REPR 0 Table of Contents

REPR 1 Repairs: Requirements

Section 1.0 Purpose

Section 2.0 Scope

Section 3.0 Target Audience

Section 4.0 General

Section 5.0 Leak Repairs

Section 6.0 Common Repair Considerations Steel Pipe

Section 7.0 Transmission and High-Pressure Distribution Pipe Repair

Section 8.0 Steel Distribution Pipe Repair

Section 9.0 PE Pipe Repair

Section 10.0 Testing of Repairs

Section 11.0 Repair Records

Appendices

Appendix A - Transmission & High-Pressure Distribution Pipe Repairs

Appendix B - Steel Distribution Pipe Repairs

Appendix C - Reinforcing Split Sleeves

Appendix D - Mueller Tapered Screw Plug

Appendix E - PE Pipe Repairs

Appendix F - Electrofusion "Cold Zone"

Appendix G - Plexco Tapping Tee Replacement Caps

Compliance Requirements

Reference Documents

Document Rescission

REPR 2.1 Repairs: Compression Couplings

Section 1.0 Purpose

Section 2.0 Scope

Section 3.0 Target Audience

Section 4.0 General

UNCONTROLLED IF PRINTED

Section 5.0 Repair Methods for Below Grade Compression Couplings

Section 6.0 Compression Joints on Steel Tees and Valves

Section 7.0 Testing of Repairs

Section 8.0 Records

Compliance Requirements

Reference Documents

Document Rescission

REPR 2.2 Repairs: Plidco Split+Sleeves

Section 1.0 Purpose

Section 2.0 Scope

Section 3.0 Target Audience

Section 4.0 General

Section 5.0 Material Storage

Section 6.0 Installation

Section 7.0 Seal Welding

Appendices:

Appendix A - Plidco Split+Sleeve Reference and Dimension Data

Appendix B - Torque Values for Studs/Nuts

Compliance Requirements

Reference Documents

Document Rescission

REPR 2.3 Repairs: Leaking Aldyl-A Tapping Tee Caps

Section 1.0 Purpose

Section 2.0 Scope

Section 3.0 Target Audience

Section 4.0 General

Section 5.0 Repair Kit Components

Section 6.0 Tools

Compliance Requirements

Reference Documents

Document Rescission

REPR 3 Repairs: Forms and Reference Materials

Forms

References

Document Rescission

End of Table of Contents

Document Rescission

REPR 0 Repairs: Table of Contents, December 15, 2021.

Revision Notes

Location of Changes	Summary of Changes
REPR 1, Appendix C	Changed to Reinforcing Split Sleeves. Dresser and Allen Edwards are approved manufacturers for these sleeves.

REPAIRS

April 1, 2023

REPR 1 Requirements**1.0 Purpose**

This document prescribes the methods for repairing transmission and high-pressure distribution pipelines, steel distribution pipe/mains, polyethylene (PE) mains, and service lines by Ameren Illinois (AIC). All work is to comply with 49 CFR Part 192, Subpart E, Subpart G (specifically §§ 192.309 and 192.311), and Subpart M.

2.0 Scope

This document addresses the following:

[3.0 Target Audience](#)**[4.0 General](#)****[5.0 Leak Repairs](#)****[6.0 Common Repair Considerations - Steel Pipe](#)****[7.0 Transmission and High-Pressure Distribution Pipe Repair](#)****[8.0 Steel Distribution Pipe Repair](#)****[9.0 Polyethylene \(PE\) Pipe Repair \(§192.311\)](#)****[10.0 Testing of Repairs](#)****[11.0 Repair Records](#)**

Appendices

[Appendix A - Transmission & High-Pressure Distribution Pipe Repairs](#)**[Appendix B - Steel Distribution Pipe Repairs](#)****[Appendix C - Reinforcing Split Sleeves](#)****[Appendix D - Mueller Tapered Screw Plug](#)****[Appendix E - PE Pipe Repairs](#)****[Appendix F - Electrofusion "Cold Zones"](#)****[Appendix G - Plexco Tapping Tee Replacement Caps](#)****3.0 Target Audience**

- Gas Engineering
- Gas Tech Engineering (GTE)
- Gas Integrity Management Personnel
- Gas Supervisors
- Gas Field Personnel
- Gas Field Personnel - Welders
- Gas Tech Services (GTS) Supervisors
- Gas Storage Engineering (GSE)
- Gas Storage Field Supervision
- Gas Storage Field Operators
- Gas Construction Services Supervisors
- Contract Gas Construction Company Supervisors
- Contract Construction Inspectors
- Contract Welding Inspectors
- Gas Control

UNCONTROLLED IF PRINTED

- Gas Tech Services (GTS) Technicians

4.0 General

- 4.1 Any pipeline facility that is damaged, deteriorated, or contains an imperfection that impairs serviceability, or a pipeline that is leaking shall be:
 - 4.1.1 Removed and replaced with a section of pipe of equal or greater design strength, OR
 - 4.1.2 Repaired by one of the approved methods specified in this document.
- 4.2 When determining the type of repair to make, consider the following:
 - 4.2.1 Type of pipe,
 - 4.2.2 Type of defect or damage,
 - 4.2.3 Leaking or non-leaking,
 - 4.2.4 System MAOP,
 - 4.2.5 Personnel and public safety, AND
 - 4.2.6 Availability of repair fittings.
- 4.3 To protect the public and personnel, consider controlling gas flow before making repairs or be prepared to control gas, if necessary, while repairs are being made. Methods of controlling the flow may include:
 - 4.3.1 Throttling or shutting off main and service line valves,
 - 4.3.2 Using line stopping equipment,
 - 4.3.3 Changing regulator set points,
 - 4.3.4 Running down the tap on service line tees, OR
 - 4.3.5 Activation of excess flow valves (EFV).
- 4.4 Consult with Gas Control to verify if the affected system is remotely monitored. If monitored, request their assistance in monitoring the system during the repair operation.
 - 4.4.1 Establish communications and determine at what point Gas Control should issue a warning of potential system problem.
 - 4.4.2 Once repair has been completed and system returned to normal operation, verify with Gas Control that operating parameters indicate back to normal operation.
- 4.5 If any imperfection or damage is discovered and determined to be unsafe, then a plan shall be identified / implemented to make the situation safe by considering:
 - 4.5.1 Reducing pressure as part of planned action,
 - 4.5.2 Isolating and shutting down the damaged sections, OR
 - 4.5.3 Constructing a bypass and shutting down the damaged section.
- 4.6 See [SAFT 1, Section 4.0](#), Regulatory Requirements for safety related condition (SRC) reporting that may be required to PHMSA and the ICC.
- 4.7 If affected facility is a transmission or high-pressure distribution line with MAOP greater than 100 psig, notify GTE, Pipeline Integrity Management, or GSE of the situation before performing repairs.

- 4.8 When measuring / evaluating damage or corrosion on steel pipe, the appropriate Operator Qualified (OQ) personnel should complete a Corrosion and Steel Damage Evaluation form. See [CORR 2.9](#).
- 4.9 When steel pipe repair includes replacing a cut-out section of damaged or deteriorated pipe with PE pipe, consult corrosion control personnel to ensure adequate cathodic protection (CP) for the affected pipeline segment.
- 4.10 For defects on curved pipe, consult GTS, GTE, or GSE to determine appropriate repair options.
- 4.11 All permanent repairs shall be made by an approved method specified in:
- 4.11.1 [Appendix A](#) - Transmission & High-Pressure Distribution Pipe Repairs,
 - 4.11.2 [Appendix B](#) - Steel Distribution Pipe Repairs,
 - 4.11.3 [Appendix E](#) - PE Pipe Repair, OR
 - 4.11.4 If necessary, by reliable engineering test and analyses to ensure restoring serviceability of the pipe.
- 4.12 If not feasible to make a permanent repair on steel mains or services at the time of discovery, then complete a "Make Safe" repair. A permanent repair shall be completed within 90 calendar days.
- 4.12.1 Exceptions:
- 1. A Class 1 leak within 5 feet of a foundation shall be *permanently repaired at the time of discovery*.
 - 2. Compression couplings shall be repaired *within 30 calendar days* (see [REPR 2.1](#)).
- 4.12.2 Initiate a leak repair in ClickMobile and include a note indicating that it is a Make Safe repair.
- 4.12.3 Gas Supervisor is responsible for tracking the required permanent repair by creating a job order, DOJM, that includes:
- 1. Make Safe repair date.
 - 2. Permanent repair due date, no later than 90 days from the Make Safe repair date.
- 4.13 Safety considerations:
- 4.13.1 When working in a potentially hazardous gas environment, follow [WIGE 2.1](#).
 - 4.13.2 Before welding or cutting activity on any steel pipeline, take the proper precautions to eliminate any chance of accidental ignition. See [ACIG 2, Section 6.0](#), Welding and Other Hot Work.
 - 4.13.3 A fire extinguisher shall be at the location of the work when there is a potential for an ignition

5.0 Leak Repairs

- 5.1 Any facility that is leaking to the extent that an immediate hazard exists (Class 1 leak) shall be repaired immediately.
- 5.2 If the operating pressure cannot be reduced to a safe level, the affected piping system shall be taken out of service.

- 5.3 If a leak is caused by corrosion, complete a Corrosion and Steel Damage Evaluation within ClickMobile. See [CORR 2.9](#).
- 5.4 Corrosion Control personnel should determine if further investigation / testing is needed to ensure adequate CP is being maintained, all depending upon:
 - 5.4.1 Condition of the pipe,
 - 5.4.2 Pipe coating, AND
 - 5.4.3 Extent of the corrosion.
- 5.5 In a gas storage field, installing two barriers is considered a permanent repair for a leak on a storage field well. A barrier consists of installing a bridge plug, loading the well with water, or other engineered barrier method.
- 5.6 Leaks in compression couplings and fittings are covered in [REPR 2.1](#).
- 5.7 Leaks in threaded connections can be repaired by:
 - 5.7.1 Tightening the fittings,
 - 5.7.2 Disassembling and applying thread sealer or Teflon thread tape and reassembling (see [STLP 1](#)), OR
 - 5.7.3 Replacing the fittings.
- 5.8 Leaks in flange connections can be repaired by:
 - 5.8.1 Tightening the flange bolts, AND/OR
 - 5.8.2 Replacing the flange gasket.

6.0 Common Repair Considerations - Steel Pipe

6.1 Segment Cutout

Before cutting metallic gas piping, install an electrical bond and maintain it until all reconnections are completed, or a gas-free environment exists.

- 6.1.1 Repair by cutting out the defective segment of pipe and replacing with pipe that is appropriate for the Design MAOP.
 - 6.1.2 Consult with cathodic protection personnel for CP requirements on new segment of pipe.
 - 6.1.3 The minimum length of replacement segment shall be:
 - 1. *For pipe sizes up through 8-inch nominal OD:* 12-inches minimum.
 - 2. *For pipe sizes greater than 8-inch nominal OD:* At least 1-1/2 times the pipe diameter.
 - 6.1.4 When determining the length of cut-out segment, consider the size of line-up clamps, ease of alignment and fit-up, need for reinforcing sleeve over girth weld, and other construction conditions.
 - 6.1.5 New segment shall be connected to existing pipe by an approved welding procedure.
- ### 6.2 Grinding (§192.309)

6.2.1 Grinding may only be used for repairs as listed in:

1. [Appendix A](#) for Transmission & High-Pressure Distribution Pipe Repairs.

Consult with Gas Tech Engineering before grinding to repair any defect on transmission piping or high-pressure distribution piping operating above 100 psig.

2. [Appendix B](#) for Steel Distribution Pipe Repairs.

6.2.2 Use grinding only if the affected pipe material can be removed without requiring a permanent reduction in maximum operating pressure (MOP) of the piping. This can be computed using the remaining strength formula from ASME B31G (or an equivalent calculation), or the more conservative design formula in [STLP 2.2, Subsection 4.1](#).

6.2.3 Perform arc burn removal in accordance with [WELD 2.10](#).

6.2.4 During repair of a defective weld, where applicable, lower the operating pressure to less than 20% SMYS. Limit grinding of the defective area so at least 1/8-inch thickness remains in the pipe weld. Further welding shall only be with an approved procedure.

6.3 Welded Full-Encirclement **Reinforcing** Split Sleeve

6.3.1 Reinforcing sleeves are suitable for repairing pipe (non-leaking or leaking) or welds, provided leakage can be safely controlled during the pipe surface preparation and welding.

6.3.2 Full-encirclement split sleeves are suitable to reinforce the pipe for internal defects (e.g., laminations, internal corrosion), provided that:

1. Sleeve extends beyond the internal defect, AND
2. Sound metal is far enough away from defect so that localized heating will not have an adverse effect on the defect.

6.3.3 Ensure that the pressure rating of the selected split sleeve is adequate for the pipeline being repaired.

6.3.4 Clean pipe and remove existing coating material in the area where sleeve is to be welded.

1. Remove coating beyond the area to be sleeved, taking care not to remove metal from the pipe.
2. If severe corrosion is present, contact Gas Supervisor to determine if a split sleeve is appropriate. Gas Supervisor may need to confirm with Gas Engineering, GTE, GSE, and/or Corrosion Control personnel. For corrosion evaluation, see [CORR 2.9](#).

6.3.5 Welding of the full encirclement sleeve shall be in accordance with [WELD 2.4](#).

6.3.6 When the sleeve is for permanent repair, coat the sleeve with an approved coating. See [CORR 2.3](#).

6.4 PLIDCO Full-Encirclement Split+Sleeve

- 6.4.1 The Split+Sleeve is suitable for pipe repair by bridging over leaks and other defects in steel pipe, provided leakage can be safely controlled during the necessary pipe surface preparation.
- 6.4.2 The Plidco Split+Sleeve is acceptable for both Make Safe repair and permanent repair of steel pipe.
- 6.4.3 For installation procedure and material specifications, see [REPR 2.2](#).
- 6.4.4 Permanent repairs require the repair sleeve to be seal welded.

6.5 Composite Wrap Systems

- 6.5.1 These high strength carbon fiber or glass resins are a flexible alternative to repair clamps, welded sleeves, and pipe replacement.
- 6.5.2 These systems are a rehabilitation option for steel gas pipes with external corrosion, gouges, grooves, dents, and internal defects (e.g., laminations, corrosion).

Composite wrap systems are only applicable for non-leak repair.

- 6.5.3 Before specifying this type of repair, consult GTE to evaluate the pipe damage and applicability.
- 6.5.4 If composite wrap is determined to be an appropriate repair method, **follow the manufacturer's installation instructions.**

1. Approved composite wrap:

1a. Syntho-Glass XT

1b. Clock Spring

1c. OmegaWrap

2. See [REPR 3](#) for:

2a. Syntho-Glass XT Engineering Assessment Form and Installation

2b. Clock Spring Coil Pass Method Installation Manual

2c. Clock Spring Underwater Installation Guide

2d. OmegaWrap Installation Procedures

3. Before using another brand of composite wrap, it must be approved by Gas Standards & Materials in coordination with Corrosion Control and GTE.

6.6 Weld Deposition

- 6.6.1 Non-leaking weld defects may be repaired by deposition welding if the pipeline pressure can be reduced to a safe level and minimum wall thickness requirements are met.
- 6.6.2 The operating pressure must be at a safe level during the repair operation. For transmission lines, a safe level is below 20% SMYS.

6.7 Encapsulation

Full encirclement split sleeves and Plidco Split+Sleeve encapsulation are covered in [Subsection 6.3](#) or [Subsection 6.4](#).

6.7.1 Acceptable methods of encapsulation include:

1. *Approved manufactured fittings*, such as Mueller or T.D. Williamson line stopper, short stop, and save-a-valve nipple, can be used to encapsulate a leak, including leaking or abandoned fitting (or tapered screw plug).
2. *Steel pipe with a welded cap* is an acceptable means for encapsulating a leaking or abandoned fitting. This is referred to as pipe/cap method.

6.7.2 Encapsulation is not allowed over girth welds.

6.7.3 Common Encapsulation Considerations

1. Consult GTE and/or Integrity Management to determine if encapsulation is an acceptable repair option.
2. Ensure that the manufactured fitting has appropriate pressure rating for the pipeline on which it is being installed.
3. Attach manufactured fitting or pipe/cap to pipeline by an approved welding procedure. See [WELD 2.4](#) for in-service welding and [WELD 4](#) for related procedures.
4. Leak test the final weld at normal operating pressure with leak detection fluid or leak detection instrument.
5. Document the pressure test on ClickMobile leak repair form.
6. Coat fitting with an approved coating. See [CORR 2.3](#).

6.7.4 Added Considerations

1. *For manufactured fitting*, permanently attach the cap by tack-welding or strapping to prevent removal.
2. *For pipe/cap method*, pretest steel pipe at pressure that qualifies MAOP to be same as pipeline on which being attached. See [PTST 1.1 Table E](#), Fabricated Unit/Assembly or Short Section of Pipe.

6.8 Stainless-Steel Bolted Leak Clamp

- 6.8.1 The stainless-steel bolted leak clamp is limited to maximum pressure of 60 psig. Therefore, it can be used for a Make Safe repair on systems operating over 60 psig **IF** the operating pressure can be reduced to the clamp rating or less.
- 6.8.2 A permanent repair requires a full-encirclement welded split-sleeve to be installed over the clamp **IF** the pipe operating pressure is over 60 psig.
- 6.8.3 The stainless-steel bolted leak clamp is a permanent repair on pipe with MAOP of 60 psig or less.
- 6.8.4 The clamp shall be coated with approved coating when used as a permanent repair. See [CORR 2.3](#).
 1. The clamp does not have to be coated when used as a Make Safe repair.

7.0 Transmission and High-Pressure Distribution Pipe Repair

- 7.1 When any transmission line or high-pressure distribution pipeline is discovered as damaged or deteriorated such that its serviceability is impaired, the Gas Supervisor or Gas Engineer shall notify Pipeline Integrity, GTE, or GSE.

Any high-pressure service lines that might operate at or above 20% SMYS shall be repaired using one of the approved methods for transmission lines.

- 7.2 All permanent repairs of transmission facilities shall be piggable.
- 7.3 Gas Field Personnel will:
- 7.3.1 Make initial determination of the damage or leak.
 - 7.3.2 Identify extent of gas leak migration as needed.
 - 7.3.3 Classify any leaks. See [LEAK 1, Subsection 5.5](#).
 - 7.3.4 Perform required leak surveillance.
 - 7.3.5 Take appropriate measures to protect public and property until repairs are made.
 - 7.3.6 Communicate status updates with Gas Supervisor or Gas Engineer.
 - 7.3.7 Assist GTS with repairs when requested.
- 7.4 Pipeline Integrity, GTE, GSE, or Region Gas Engineer will:
- 7.4.1 Evaluate damage or deterioration of the main.
 - 7.4.2 Determine extent of repairs required.
 - 7.4.3 Determine safe operating pressure that can be maintained during repair.
 - 7.4.4 Recommend corrective action to be taken.
 - 7.4.5 Prepare corrective action plan, if necessary.
 - 7.4.6 Identify if any corrosion control measures need addressed.
 - 7.4.7 Ensure necessary material is available on/to site.
 - 7.4.8 Coordinate actual repairs to be performed by either contractor or AIC personnel.
- 7.5 Pipeline Integrity, GTE or GSE may recommend a repair method that is not currently shown in Appendix A as approved for transmission or high pressure distribution facilities.
- 7.5.1 The recommended repair method shall be:
- 1. Based on good engineering and industry practice.
 - 2. Installed or performed in accordance with manufacturer's instructions
 - 3. Performed by individuals qualified in the process.
 - 3a. AIC's Operator Qualification group shall review the method and determine if the repair method requires individuals to be Operator Qualified.
 - 4. Submitted in writing for evaluation and approved by the Supervising Engineer Gas Standards & Procedures prior to installation.

- 7.5.2 If the recommended repair method is approved, a copy of the written approval and a copy of the manufacturer's instructions shall become part of the final repair job packet and maintained for the life of the facility.

7.6 Approved Repair Methods

- 7.6.1 Imperfections or damage (e.g., gouges, grooves, dents, arc burns) to a transmission line should be closely inspected and repaired in accordance with [Appendix A](#).

1. The appendix table indicates the approved repair method for various types of defects or imperfections on transmission and high-pressure distribution piping. In addition, encapsulation of a leak (including a leaking and/or abandoned fitting) is also an approved method.

- 7.6.2 See repair coverage in [Section 6.0](#), Common Repair Considerations - Steel Pipe as follows:

1. Segment Cutout - [Subsection 6.1](#)
2. Grinding - [Subsection 6.2](#)
3. Welded Full-Encirclement Split Sleeve - [Subsection 6.3](#)
4. PLIDCO Full-Encirclement Split+Sleeve - [Subsection 6.4](#)
5. Composite Wrap Systems - [Subsection 6.5](#)
6. Weld Deposition - [Subsection 6.6](#)
7. Encapsulation - [Subsection 6.7](#)
8. Stainless Steel Bolted Leak Clamp - [Subsection 6.8](#)

7.7 High Pressure Distribution and Transmission Pipe Grinding Repair (§192.309)

Consult with Gas Tech Engineering or Gas Integrity before grinding to repair any defect on transmission piping or high-pressure distribution piping operating above 60 psig.

- 7.7.1 Grinding is an approved repair method as specified in [Appendix A](#) and approved by engineering.
- 7.7.2 For Arc Burn removal see [WELD 2.10](#)
- 7.7.3 Use grinding as a repair method only if the remaining wall meets the requirements of ASME B31G
- 7.7.4 Use 60 grit or finer abrasive wheel for grinding repairs.
- 7.7.5 Project specific procedures will specify the pressure and wall thickness requirements for grinding repairs.

Care should be taken when grinding on pre-1970 ERW pipe. The seam weld may be difficult to locate, may have low toughness, and may contain imperfections.

- 7.7.6 Ensure a minimum 10 pound dry chemical (A, B, C) fire extinguisher is present at the location of the work when grinding on an operational line.
- 7.7.7 Remove coating and abrasive blast the grinding area.
- 7.7.8 An initial and final NDT inspection is required for transmission and high-pressure distribution welding repairs.
 - 1. Perform a radiographic test for repairs on girth welds. See [WELD 2.6](#).
 - 2. Perform a magnetic particle test for repairs on fillet welds (lap and branch type). See [WELD 2.7](#).
- 7.7.9 Record the minimum wall thickness of the area around the anomaly or indication.
 - 1. If wall thickness indicates additional anomalies or wall loss, contact GTE/GSE or Gas Integrity prior to grinding.
- 7.7.10 Keep in constant motion using light to moderate pressure to prevent overheating (blueing) of the pipe.
- 7.7.11 Periodically stop grinding in order to evaluate the wall thickness.
- 7.7.12 Final surface area should have a smooth profile.
 - 1. Additional buffing/blending may be required.
- 7.7.13 Record the final wall thickness on the as-built documents.

8.0 Steel Distribution Pipe Repair

- 8.1 All repairs on steel distribution pipe shall be by one of the approved repair methods. See [Appendix B](#) and coverage below for half-sole sleeve and tapered screw plug.
- 8.2 Approved Repair Methods
 - 8.2.1 See coverage in Section 6.0, Common Repair Considerations - Steel Pipe as follows:
 - 1. Segment Cutout - [Subsection 6.1](#)
 - 2. Grinding - [Subsection 6.2](#)
 - 3. Welded Full-Encirclement Split Sleeve - [Subsection 6.3](#)
 - 4. PLIDCO Full-Encirclement Split+Sleeve - [Subsection 6.4](#)
 - 5. Composite Wrap Systems - [Subsection 6.5](#)
 - 6. Weld Deposition - [Subsection 6.6](#)
 - 7. Encapsulation - [Subsection 6.7](#)
 - 8. Stainless Steel Bolted Leak Clamp - [Subsection 6.8](#)
 - 8.2.2 Half-Sole Sleeve
 - 1. Half-sole steel repair sleeves can be used for internal and external corrosion, gouges, dents, grooves, arc burns, cracks, and laminations on distribution piping only.

Half-sole sleeve must extend beyond the area of lamination and welded to sound pipe.

2. Half-sole sleeves are available commercially in two pressure-rated steels or a single structural-grade steel.
 - 2 a. Use pressure-rated sleeves to repair non-leaking defects.
 - 2 b. Use structural-grade sleeves as reinforcement only for a defective area.
3. Half-sole sleeves can be procured in various lengths.
4. A half-sole sleeve may be made from pipe or rolled plate material of appropriate grade, equal or greater thickness, and with rounded corners.

8.2.3 Tapered Screw Plug

1. Use tapered screw plugs only to plug small non-corrosion holes in steel distribution lines.
2. **Do not** use tapered screw plugs:
 - 2 a. In lines operating over 60 psig.
 - 2 b. To repair corrosion leaks.
 - 2 c. In any pipelines that are subject to pigging.
3. See [Appendix D](#), Mueller Tapered Screw Plug for available sizes and installation procedure.

8.3 Distribution Pipe Grinding Repairs (§192.309)

Care should be taken when grinding on pre-1970 ERW pipe. The seam weld may be difficult to locate, may have low toughness, and may contain imperfections.

- 8.3.1 Grinding is an approved repair method as specified in [Appendix B](#)
- 8.3.2 For Arc Burn removal see [WELD 2.10](#)
- 8.3.3 Use grinding as a repair method only if the remaining wall thickness meets the requirements of ASME B31G.
- 8.3.4 Ensure a minimum 10 pound dry chemical (A, B, C) fire extinguisher is present at the location of the work when grinding on an operational line.
- 8.3.5 Use 60 grit or finer abrasive wheel for grinding repairs.
- 8.3.6 Remove coating and abrasive blast the grinding area.
- 8.3.7 An initial and final NDT inspection is required for in-service distribution welding repairs.
 1. Perform a radiographic test for repairs on girth butt welds. See [WELD 2.6](#).

2. Perform a magnetic particle test for repair on fillet welds (lap and branch type). See [WELD 2.7](#).
- 8.3.8 Record the minimum wall thickness of the area around the anomaly or indication.
 1. If wall thickness indicates additional anomalies or wall loss, contact Gas Engineering or Gas Integrity prior to grinding.
- 8.3.9 Keep in constant motion using light to moderate pressure to prevent overheating (blueing) of the pipe.
- 8.3.10 Final surface area should have a smooth profile.
 1. Additional buffing/blending may be required.
- 8.3.11 Record the final wall thickness on the as-built documents.

9.0 Polyethylene (PE) Pipe Repair (§192.311)

9.1 General

- 9.1.1 Any leak, imperfection, or damage that impairs the serviceability of a plastic pipe shall be repaired or removed. See [Appendix E](#) for approved repair methods for polyethylene (PE) pipe. These methods are applicable to medium-density polyethylene (MDPE) pipe and high-density polyethylene (HDPE) pipe.
- 9.1.2 Escaping gas from PE pipe can generate static electricity. For grounding procedures, see [POLY 2.2, Paragraph 5.1.3](#).
- 9.1.3 Stainless steel bolted leak clamps are not designed for use on PE pipe. Therefore, do not use for leak repairs on PE pipe.
- 9.1.4 Ensure a minimum 10 pound dry chemical (A, B, C) fire extinguisher is present at the location where the work is being performed.

9.2 Segment Cutout

- 9.2.1 Repair PE piping by cutting out the damaged section and installing pretested replacement pipe.
- 9.2.2 The new segment should be attached to the existing pipe with either butt fusion or electrofusion couplings. Service lines 1 inch and smaller may be connected with a mechanical stab coupling. See [POLY 2.6](#).

9.3 Electrofusion Repair Saddles

- 9.3.1 Repair saddles can be used on:
 1. *Non-leaking defects* such as gouges and nicks of any depth.
 2. *Leaking defects* if the line is shut down for the repair.
- 9.3.2 The maximum size defect that can be repaired with a repair saddle is 2 inches in length and width. Center repair saddle over the defect so that the defect is in the fitting "cold zone." See [Appendix F](#) for explanation of electrofusion cold zone.
- 9.3.3 Repair saddles are available for 4-inch and 6-inch PE pipe. See [POLY 2.5, Appendix A, Item A-8](#) for repair saddle stock codes.
- 9.3.4 The repair saddle comes with an under-saddle. For installation procedure, see [POLY 2.5, Subsection 10.2](#), Saddle Fittings.

9.4 Service Line Use Only

9.4.1 Mechanical Stab Coupling or Repair Couplings (see [POLY 2.6](#))

1. Stab couplings can be used as permanent repair on PE service lines ½ thru 1-inch sizes.
2. Perfection Permasert or Continental Stab Couplings are available in ½ thru 1-inch sizes.
3. Manufacturer specific chamfering tool must be used with the specific fittings.

9.4.2 Electrofusion Coupling

1. If the damaged section of PE pipe can be cut out and there is enough slack in the remaining pipe, an electrofusion coupling can be installed to rejoin pipe.
2. Install the electrofusion coupling in accordance with procedures in [POLY 2.5](#).

9.4.3 Aldyl Service Punch Tee Repair Kit

1. To repair leaking Aldyl-A tapping tee caps, use the Kerotest electrofusion repair kit.
 - 1 a. Kits are available for both standard and non-standard tapping tees.
 - 1 b. See [REPR 2.3](#) for required tooling and installation instructions.
2. Leak test the completed repair with leak detection solution or leak detection instrument at normal operating pressure.

9.4.4 Plexco Tapping Tee Replacement Cap

1. See [Appendix G](#) for a list of the stock coded Plexco tapping tee replacement caps.
2. Leak test the completed repair with leak detection solution or leak detection instrument at normal operating pressure.

10.0 Testing of Repairs

10.1 All piping repairs must be inspected and tested in accordance with 49 CFR Part 192, Subpart J and to avoid a possible de-rating of the system.

10.1.1 Test all pipe and/or fittings used to make the repair same as new construction in the same location. Test in accordance with [PTST 1](#), including any temporary piping used as a bypass.

10.1.2 Where not feasible to pressure test a repair section after installation, the pipe and fittings shall be pressure tested before installation.

10.1.3 For permanent leak repair, leak test the full encirclement split sleeve (i.e., welded, Plidco, or Dresser) at the pipe operating pressure as a minimum. Check for leaks using a soap test or gas leak detector.

10.1.4 For tie-in welds or flanged connections that cannot be pressure tested, use a leak detection solution and leak test them together with the piping facility at operating pressure.

10.1.5 *Service line test requirements:*

1. Each line that is physically disconnected shall be tested in the same manner as a new service line before being reinstated.

2. Each line that is temporarily disconnected from the main for any reason shall be tested from the disconnection point to meter valve in the same manner as a new service line.
3. If provisions are made to maintain continuous service during the test (e.g., installing a bypass), then it is not necessary to test any part of the original service line that is used to maintain service. Refer to [RNST 1, Section 5.0](#), Reconnection of Temporarily Disconnected Services.
4. Each line disconnected from the supply source due to third-party damage shall be leak surveyed from the point of disconnection or damage to the main with a FI unit, gas detection instrument, or bar testing with CGI.

10.2 Testing Weld Repairs

- 10.2.1 Each weld shall be visually inspected by a qualified welding inspector, including welds on full encirclement split sleeve for non-leak repair.
- 10.2.2 If MAOP of the main is more than 20% SMYS and the pipe is greater than 6-inch diameter, then each weld shall be nondestructively tested. See requirements as addressed in [WELD 1, Section 9.0](#), Inspection and Test of Welds, and [WELD 1, Section 10.0](#), Nondestructive Testing.

11.0 Repair Records

11.1 Pressure Tests

- 11.1.1 If pipe, fittings, or an assembly requiring pressure testing per [PTST 1](#) is used to repair a leak, record the actual test pressure and duration on the Leak Repair Form within ClickMobile. This includes pre-testing and post-installation information.
 1. Retain record in Maximo for repairs associated with the gas leak.
- 11.1.2 Record repairs on the appropriate Leak Test Form (LTF) or Leak & Strength Test Form (LSTF). See [PTST 3](#) for forms. Retain a copy with the DOJM/WO job packet as follows:
 1. *Leak repair on a main*: Record the required pressure test information for the pipe, fittings, or an assembly used to repair the leak.
 2. *Components installed*: Record the leak test in order to complete repair on a main or service line.
 3. If using pipe, fittings, or an assembly to repair a non-leak defect that requires pressure testing per [PTST 1](#), record the actual test pressure and duration on appropriate form. This includes pre-testing and post-installation test information.
- 11.1.3 Tie-in connections that are leak tested at the normal line operating pressure should be recorded as:
 1. Repair Successfully Leak Tested on the Leak Repair Form in ClickMobile,
OR
 2. Tie-In Joints Tested on the Leak Test Form (LTF) or Leak & Strength Test Form (LSTF) as appropriate for non-leak repairs.

11.2 Repair records should include the date, location, and description of each repair made to the pipe including the pipe-to-pipe connection.

- 11.2.1 *Leak repairs*: Maintain records in Maximo for life of the facility.

UNCONTROLLED IF PRINTED

11.2.2 *Non-leak repairs*: Maintain records in the job packets for life of the facility.

11.3 Weld Tests

11.3.1 The test reports and non-destructive testing (NDT) inspection reports shall be retained in the job packets for life of the pipeline.

11.3.2 The radiographic films will be identified and retained in the job packet for 3 years, subject to disposal as established in [WELD 2.6, Subsection 10.2](#).

End of Instructions.

Operator Qualification (OQ) Required?

YES

0641: Visually Inspect Pipe and Components Prior to Installation

0681: Joining of Plastic Pipe - Stab Fittings

0751: Joining of Plastic Pipe - Butt Heat Fusion: Manual

0761: Joining of Plastic Pipe - Butt Heat Fusion: Hydraulic Machine

0781: Joining of Plastic Pipe - Electrofusion

0801: Welding

0811: Visual Inspection of Welding and Welds

0861: Installation of Steel Pipe in a Ditch

0901: Installation of Plastic Pipe in a Ditch

0981: Backfilling

0991: Coating Application and Repair - Brushed or Rolled

1011: External Coating Application and Repair - Wrapped

1041: Install Mechanical Clamps and Sleeves - Bolted

1051: Fit-Up of Weld Type Repair Sleeve

1061: Install Composite Sleeve

1071: Repair of Steel Pipe by Grinding

1141: Squeeze Off Plastic Pipe

1201: Temporary Isolation of Service Lines and Service Discontinuance

1371: Operate Gas Pipeline – System Control Center Operations

Appendices

[Appendix A - Transmission & High-Pressure Distribution Pipe Repairs](#)

[Appendix B - Steel Distribution Pipe Repairs](#)

[Appendix C - Reinforcing Split Sleeves](#)

[Appendix D - Mueller Tapered Screw Plug](#)

[Appendix E - PE Pipe Repairs](#)

[Appendix F - Electrofusion "Cold Zones"](#)

[Appendix G - Plexco Tapping Tee Replacement Caps](#)

Attachments

NONE.

Compliance Requirements

49 CFR Part 192, Subpart E, Subpart G (specifically §§ 192.309 and 192.311), and Subpart M.

American Society of Mechanical Engineers (ASME), B31G, "Manual for Determining the Remaining Strength of Corroded Pipelines"

Illinois Commerce Commission (ICC) Title 83: Public Utilities, Part 590, Minimum Safety Standards for Transportation of Gas and for Gas Pipeline Facilities, available online [here](#).

Reference Documents

[ACIG 2 Accidental Ignition: Work Area Protection](#)

[CORR 1 Corrosion Control: Requirements](#)

[CORR 2.3 Corrosion Control: Coatings](#)

[CORR 2.9 Corrosion Control: Evaluation of Corrosion](#)

[LEAK 1 Leak Management: Requirements](#)

[MAIN 2.3 Main Installation: Pull-Out Prevention](#)

[POLY 2.2 Polyethylene Pipe: Squeeze Off](#)

[POLY 2.5 Polyethylene Pipe: Electrofusion](#)

[POLY 2.6 Polyethylene Pipe: Mechanical Joining](#)

[PTST 1 Pressure Testing: Requirements](#)

[PTST 3 Pressure Testing: Forms and Reference Materials](#)

[REPR 2.1 Repairs: Compression Couplings](#)

[REPR 2.2 Repairs: Plidco Split+Sleeves](#)

[REPR 2.3 Repairs: Leaking Aldyl-A Tapping Tee Caps](#)

[REPR 3 Repairs: Forms and Reference Materials](#)

[RNST 1 Requirements and Reinstating Mains and Service](#)

[SAFT 1 Safety-Related Conditions: Requirements](#)

[STLP 2.2 Steel Pipe: Design Pressure](#)

[WELD 1 Welding: Requirements](#)

[WELD 2.4 Welding: In-Service Welding](#)

[WELD 2.6 Welding: Radiographic Testing](#)

[WELD 2.10 Welding: Arc Burn Removal](#)

[WELD 4 Welding: Forms and Reference Materials](#)

[WIGE 2.1 Working In Gaseous Environment: Hazardous Environment](#)

Document Rescission

REPR 1 Repairs - Requirements, December 15, 2021.

Revision Notes

Location of Changes	Summary of Changes
2.0 Scope	Appendix C – Remove "Dresser"
Subsection 6.3	Updated title and revised – Welded Full-Encirclement Reinforcing Split Sleeves. Remove the general sentence under the section name.
Paragraph 6.5.4	Added – follow manufacturer's installation instructions. Added - AIC approved composite wraps: Syntho Glass XT, Clock Spring, and OmegaWrap. Referenced REPR 3 for the manufacturer's installation instructions.
Appendices	Appendix C – Reinforcing Split Sleeve = Removed Dresser
Appendix A – Transmission & High-Pressure Distribution Pipe Repairs	Header – Reinforcing Split Sleeve replace Type B Sleeve (Dresser 110 or 220)
Appendix B – Steel Distribution Pipe Repairs	Header – Reinforcing Split Sleeve replace Type B Sleeve (Dresser 110 or 220)

Appendix A - Transmission & High-Pressure Distribution Pipe Repairs

UNCONTROLLED IF PRINTED

Type of Defect Or Imperfection	Segment Cut-Out	Grinding	Reinforcing Sleeve	Composite Wrap	Weld Deposition	Plidco Split+Sleeve
<i>Reference</i>	Sect. 6.1	Sect. 6.2	Sect. 6.3	Sect. 6.5	Sect. 6.6	Sect. 6.4
Leak on pipe from any cause, or Any defect >80% wall thickness	Permanent	NO	Permanent	NO	NO	Permanent ⁶
External corrosion >10% and <80%	Permanent	NO	Permanent	Permanent	NO	Permanent ⁶
External corrosion >80%	Permanent	NO	Permanent	NO	NO	Permanent ⁶
Internal defect (laminations, cracks, corrosion, etc.)	Permanent	NO	Permanent ²	Permanent ²	NO	NO
Gouge or other metal loss on pipe body	Permanent	Permanent ³	Permanent	Permanent ⁴	NO	Permanent ⁶
Arc burn on pipe with MAOP ≥ 40% SMYS	Permanent	See WELD 2.10	Permanent	Permanent ⁴	NO	Permanent ⁶
Smooth dent ¹	Permanent	NO	Permanent	Permanent	NO	Permanent ⁶
Dent with stress concentrator, crack, or metal loss	Permanent	Permanent ³	Permanent	Permanent ⁴	NO	Permanent ⁶
Dent with stress concentrator on seam or girth weld	Permanent	Permanent ³	Permanent	NO	NO	Permanent ⁶
Dents, wrinkles, buckles, or collapses > 15% of pipe dia. ⁶	Permanent	NO	NO	NO	NO	NO
Shallow crack <40% wall thickness	Permanent	Permanent ³	Permanent	Permanent	NO	Permanent ⁶
Deep crack >40% and <80% wall thick.	Permanent	NO	Permanent	Permanent	NO	Permanent ⁶
Non-leaking weld defect	Permanent	Permanent ³	Permanent	N/A	Permanent ⁵	Permanent ⁶
Leaking weld	Permanent	NO	Permanent	NO	NO ⁷	Permanent ⁶

Notes:

1. A "smooth" dent:
 - Between 2% and 6% of pipe diameter deep *should be* evaluated by Pipeline Integrity or GTE for fatigue cracking and repaired if appropriate, OR
 - Deeper than 6% of pipe diameter *must be* repaired or replaced, OR
 - On pipe with Design MAOP ≥ 40% SMYS, the dent or depression *must be* repaired or replaced if having:
 - Depth > 2% of pipe diameter on > 12-inch (nominal OD) pipe.
 - Depth > ¼ inch on 12-inch and smaller (nominal OD) pipe, OR
2. Acceptable repair only if internal defect or corrosion cannot grow beyond acceptable limits.
3. Grinding requirements to be specified by engineering. See [Subsection 7.6](#).
4. Repair may be used for defects < 80% of wall thickness deep provided that the damaged area has been removed by grinding and the defect removal has been verified by NDT inspection.
5. The defect should be removed by grinding and the area non-destructively tested before and after welding.

6. Plidco Split+Sleeve is approved as a Make Safe repair but shall be seal welded for permanent repair.
7. Weld deposition is an acceptable repair method only if the pipeline is taken out of service during repair. See [WELD 2.3. Section 10](#)
8. See [Section 6.7](#) for encapsulation considerations.

Appendix B - Steel Distribution Pipe Repairs

Type of Defect or Imperfection	Cut-Out	Grinding	Reinforcing Sleeve or Half-Sole or Plidco Split+Sleeve	Composite Wrap	Weld Deposition	Stainless Steel Bolted Leak Clamp
Reference	Sect. 6.1	Sect. 6.2	Sect. 6.3 Sect. 6.4	Sect. 6.5	Sect. 6.6	
Leak on steel pipe from any cause	Permanent	NO	Permanent ⁵	NO	NO	Permanent
Any internal or external defect > 80% wall thickness	Permanent	NO	Permanent ^{2,5}	NO	NO	NO
Any defect internal or external > 10% and < 80% wall thickness ¹	Permanent	Permanent ³	Permanent ^{2,5}	Permanent ²	NO	Permanent ²
Internal or external corrosion > 70% wall thickness	Permanent	NO	Permanent ^{2,5}	NO	NO	NO
Non-leaking weld defect	Permanent	Permanent ³	Permanent ⁵	NO	Permanent ⁴	Permanent
Leaking weld	Permanent	NO	Permanent ⁵	NO	NO ⁶	NO

Notes:

1. A defect includes any dent, crack, gouge, wrinkle, or collapse on steel distribution piping.
2. Acceptable repair only if internal defect or corrosion cannot grow beyond acceptable limits.
3. The remaining wall thickness after grinding must be equal to or greater than the nominal wall thickness required for the design pressure of the pipeline. See [Subsection 8.3](#).
4. The defect should be removed by grinding and the area non-destructively tested before and after welding. Minimum wall thickness requirements for welding must be observed.
5. Plidco Split+Sleeve is approved as a Make Safe repair but shall be seal welded for permanent repair.
6. Weld deposition is acceptable repair only if line is taken out of service during repair. See [WELD 2.3. Section 10.0](#).
7. See [Section 6.7](#) for encapsulation considerations.

Appendix C - Reinforcing Split Sleeves

C-1. Dresser Style 110 Sleeves

C-1.1 See Figure 1 for view and Table 1 for Style 110 sleeve data.

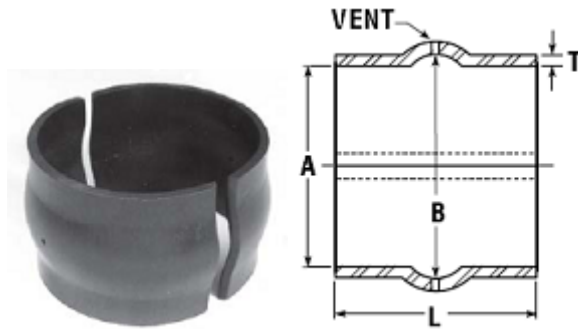

Figure 1: Dresser Style 110 Sleeve

Table 1: Dresser Style 110 Sleeve Data

Nominal Pipe Size (inches)	AIC Stock No.	Inside Diameter "A" & Pipe Diameter (inches)	Diameter "B" (inches)	Length "L" (inches)	Thickness "T" (inches)	Class 3 Pressure Rating (psig)	Manufacturer Part No.
2 *	19 33 201	2-3/8		4	1/4	2,000	0110-0002-760
3 *	19 33 202	3-1/2		5	0.237	1,470	0110-0000-550
4	19 73 231	4-1/2	5-3/8	4	5/16	2,170	0110-0001-001
6	19 33 204	6-5/8	7-1/2	6	3/8	1,815	0110-0002-005
8	19 73 225	8-5/8	9-1/2	6	3/8	1,460	0110-0003-005
10	19 33 207	10-3/4	11-5/8	6	3/8	1,210	0110-0007-005
12	19 33 208	12-3/4	14-1/4	9	1/2	1,310	0110-0002-360
14	19 33 209	14	15-1/2	9	3/8	920	0110-0018-005
16	19 33 210	16	17-1/2	12	1/2	1,080	0110-0029-001
18	19 33 211	18	19-1/2		3/8	740	0110-0033-005
20	19 33 729	20	21-1/2	12	1/2	1,106	0110-0003-690
24	19 33 730	24	25-1/2	12	1/2	937	0110-0003-700
30	19 33 731	30	31-1/2	12	1/2	581	0110-0003-710

Notes:

- * Sizes 2" and 3" have minimum yield strength of 36,000 psi.
- Size 4" and larger have minimum yield strength of 50,000 psi.
- Pressure ratings listed are based on a Class 3 design factor of 0.50.
- Pressure rating can be adjusted for Class 1, Class 2, or Class 4 locations. Design factor for Class 1 is 0.72, for Class 2 is 0.60, and Class 4 is 0.40. Contact Engineering before adjusting pressure rating.

UNCONTROLLED IF PRINTED

C-2. Dresser Style 220 Sleeves

C-2.1 See Figure 2 for view and Table 2 for Style 220 sleeve data.

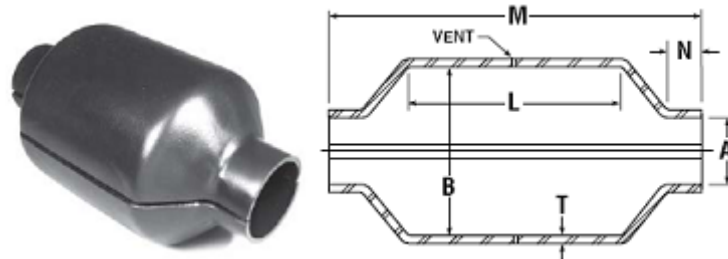

Figure 2: Dresser Style 220 Sleeve

Table 2: Dresser Style 220 Sleeve Data

Nomi- nal Pipe Size (inches)	AIC Stock No.	Inside Diame- ter "A" & Pipe Diame- ter (inches)	Diameter "B" (inches)	Inside Length "L" (inches)	Overall Length "M" (inches)	Thickness "T" (inches)	Class 3 Pres- sure Rating (psig)	Manufacturer Part No.
2 *	19 73 226	2-3/8	8-3/8	10-1/2	23-1/4	5/16	825	0220-0001-630
2	19 33 732	2-3/8	8-3/8	10-1/2	23-1/4	5/16	1,735	0220-0007-820
3 *	19 23 521	3-1/2	9-1/2	10-1/2	23-1/4	5/16	725	0220-0001-620
4	19 23 526	4-1/2	10-1/2	10	20-1/4	5/16	1,120	0220-0002-001
6	19 73 229	6-5/8	12-5/8	13-1/2	21-3/4	3/8	1,120	0220-0004-005
8	19 23 543	8-5/8	14-5/8	13-1/2	21-3/4	3/8	975	0220-0006-005
8	19 33 734	8-5/8	14-5/8	13-1/2	21-3/4	3/8	1,215	0220-0006-800
10	19 23 551	10-3/4	16-3/4	13-1/2	21-3/4	3/8	855	0220-0008-005
10	19 33 491	10-3/4	16-3/4	22-1/2	30-3/4	3/8	855	0220-0000-020
10	19 33 735	10-3/4	16-3/4	22-1/2	30-3/4	3/8	1,405	0220-0007-840
12	19 23 559	12-3/4	18-3/4	13-1/2	21-3/4	3/8	765	0220-0011-005
12	19 33 502	12-3/4	18-3/4	13-1/2	21-3/4	1/2	1,010	0220-0002-230
12	19 33 736	12-3/4	18-3/4	13-1/2	38-3/4	3/8	1,265	0220-0007-850
14	19 33 515	14	20	13-1/2	21-3/4	3/8	720	0220-0014-005
16	19 33 518	16	22	13-1/2	21-3/4	3/8	655	0220-0017-005
16	19 33 520	16	22	13-1/2	38-3/4	3/8	655	0220-0000-840

16	19 33 519	16	22	13-1/2	21-3/4	1/2	870	0220-0018-001
16	19 33 737	16	22	13-1/2	21-3/4	1/2	1,085	0220-0018-005
18	19 23 574	18	24	13-1/2	21-3/4	3/8	605	0220-0020-005
18	19 33 738	18	24	13-1/2	21-3/4	1/2	1,000	0220-0007-860
20	19 33 728	18	24	13-1/2	21-3/4	1/2	925	0220-0006-470
24	<u>Non-Stock</u>	24	30	13-1/2	21-3/4	1/2	645	0220-0029-005
30	19 23 582	30	35-7/8	16-1/4	21-3/4	3/8	400	0220-0002-260

Notes:

- * Sizes 2" and 3" have minimum yield strength of 36,000 psi; Otherwise, sleeves have minimum yield strength of 50,000 psi.
- Pressure ratings listed are based on a Class 3 design factor of 0.50.
- Pressure rating can be adjusted for Class 1, Class 2, or Class 4 locations. Design factor for Class 1 is 0.72, for Class 2 is 0.60, and Class 4 is 0.40. Contact Engineering before adjusting pressure rating.

C-3. Dresser Style 220S Sleeves

C-3.1 See Figure 3 for view and Table 3 for Style 220S sleeve data.

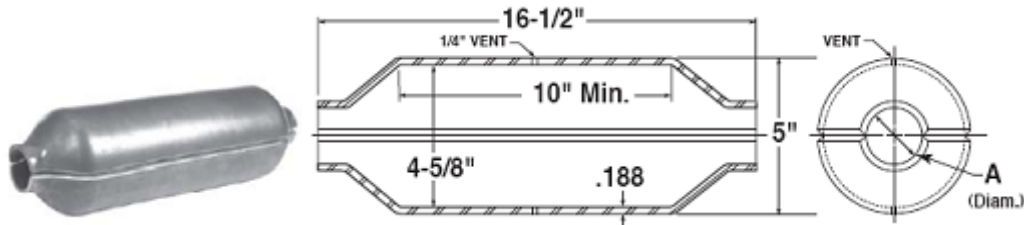

Figure 3: Dresser Style 220S Sleeve

Table 3: Dresser Style 220S Sleeve Data

Nominal Pipe Size (inches)	AIC Stock No.	Diameter "A" & Pipe Diameter (inches)	Inside Diameter (inches)	Inside Length (inches)	Overall Length (inches)	Thickness "T" (inches)	Pressure Rating (psig)	Manufacturer Part No.
3/4	19 15 569	1-1/8	4-5/8	10	16-1/2	3/16	350	0220-0111-015P
1-1/4	19 23 510	1-3/4	4-5/8	10	16-1/2	3/16	350	0220-0113-015P
2	19 23 512	2-7/16	4-5/8	10	16-1/2	3/16	350	0220-0115-015P

Notes:

- Minimum yield strength of 35,000 psi.
- Pressure ratings listed are based on a Class 3 design factor of 0.50.

3. Pressure rating can be adjusted for Class 1, Class 2, or Class 4 locations. Design factor for Class 1 is 0.72, for Class 2 is 0.60 and Class 4 is 0.40. Contact Engineering before adjusting pressure rating.

Appendix D - Mueller Tapered Screw Plug

D-1. Mueller Tapered Screw Plug

- D-1.1 The screw plugs are self-threading.
- D-1.2 Material is heat treated steel alloy.
- D-1.3 For available sizes, see Table 1.



Table 1: Mueller Tapered Screw Plugs

Hex Size (inches)	Stock Number	Length (inches)	Mueller Part Number
3/8	19 83 110	1-1/4	514258
5/8	19 83 111	2-1/8	514259
7/8	19 83 112	2-3/4	514260
1		3-1/4	514261

D-2. Installation Procedure

- D-2.1 Reduce the system operating pressure when possible to facilitate repair.
- D-2.2 Use non-sparking hammers and wrenches, if available, to turn the self-tapping plug into the hole.
- D-2.3 Fillet weld the plug to the pipe.
- D-2.4 Cut off head of plug flush with weld.
- D-2.5 Weld over top of plug to further seal or encapsulate with a pressure rated cap. See [Subsection 6.7](#) for encapsulation.

Appendix E - PE Pipe Repairs

Type of Defect OR Imperfection	Segment Cut-Out	Electrofusion Repair Saddle	Mechanical Stab Coupling	Electrofusion Coupling	Aldyl Repair Kit	Plexco Repair Kit
References	Sect. 9.2	Sect. 9.3	Sect. 9.4.1	Sect. 9.4.2	Sect. 9.4.3	Sect. 9.4.4
Leak on PE pipe from any cause	Permanent	NO	N/A	NO	NO	NO

Pipe defect > 10% wall thickness	Permanent	Permanent	N/A	NO	NO	NO
Pipe defect ≤ 10%	Permanent	Permanent	N/A	NO	NO	NO
Cut service line ≤ 1"	Permanent	NO	Permanent	Permanent	NO	NO
Cut PE pipe	Permanent	NO	N/A	Permanent	NO	NO
Leaking Aldyl service tee cap	Permanent	NO	N/A	NO	Permanent	NO
Leaking Plexco service tee cap	Permanent	NO	N/A	NO	NO	Permanent

Appendix F - Electrofusion "Cold Zones"

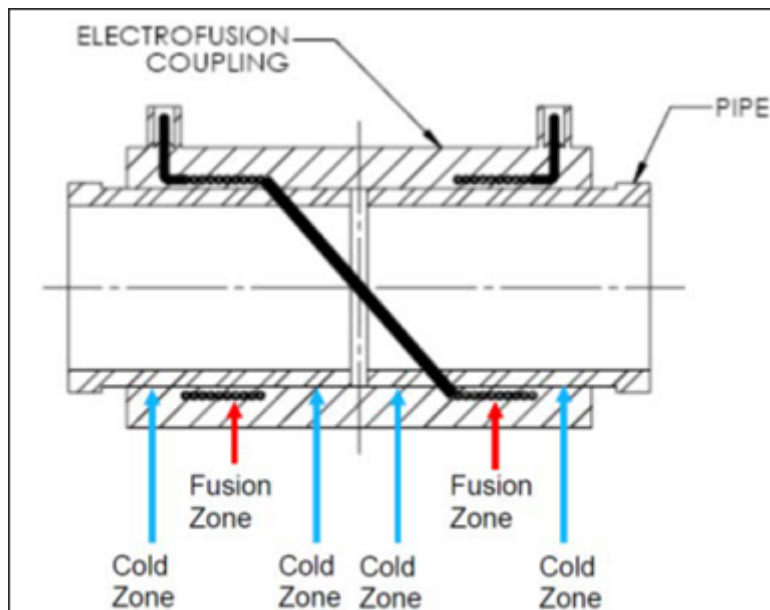

Explanation of electrofusion process and related "cold zones":

The expanding melt reaches "cold zones" within the fitting where the leading edges of melt flow cool and solidify, thereby blocking any further melt movement or escape. The heating process continues for a predetermined time so that substantial pressure is reached through continued melt expansion in the contained melt pool of the pipe and fitting surfaces.

The molten surfaces under pressure will join at the molecular level. Upon completion of the heating phase, the assembly is held stationary by external clamps as the melted materials begin to immediately cool and co-crystallize into a single homogenous monolithic structure between the pipe and fitting. Once completely cooled, the surfaces are permanently joined and cannot be separated.

Appendix G - Plexco Tapping Tee Replacement Cap

Drawing *	AIC Stock No.	Description	Col- or	Performance Pipe Part No.
-----------	---------------	-------------	---------	---------------------------

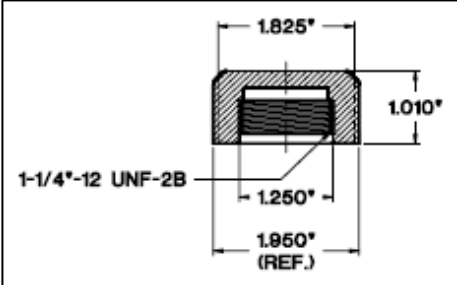
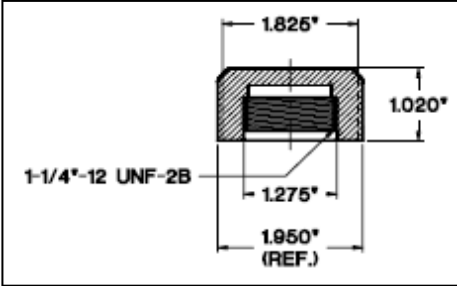
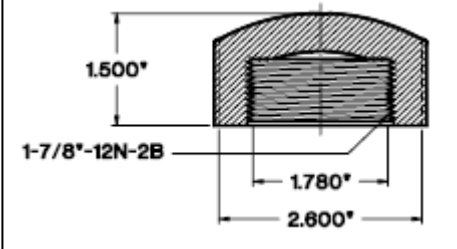
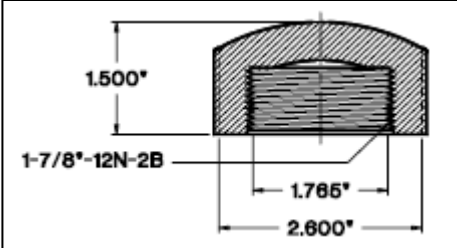
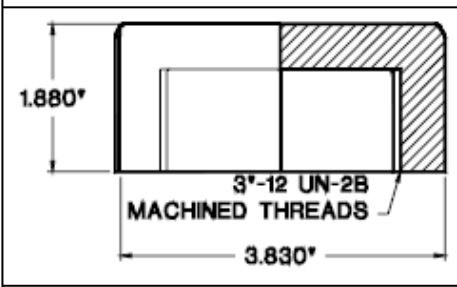
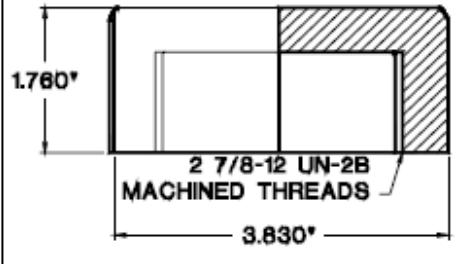
 <p>1-1/4"-12 UNF-2B</p>	<p>Non-Stock</p>	<p>Style 1 Nipak Replacement Cap with gasket</p>	<p>Yellow</p>	<p>1048201</p>
 <p>1-1/4"-12 UNF-2B</p>	<p>Non-Stock</p>	<p>Extron Replacement Cap with 2 gaskets (slightly larger thread ID than 1048201)</p>	<p>Yellow</p>	<p>1048178</p>
 <p>1-7/8"-12N-2B</p>	<p>19 72 125</p>	<p><i>Concept I</i> Standard Tapping Tee Replacement Cap with gasket (Has standard thread instead of buttress thread) Thread ID = 1.780"</p>	<p>Black</p>	<p>1073428</p>
 <p>1-7/8"-12N-2B</p>	<p>19 72 124</p>	<p><i>Concept I</i> Standard Tapping Tee Replacement Cap with gasket (Has standard thread instead of buttress thread) Thread ID = 1.765"</p>	<p>Black</p>	<p>1048299</p>
 <p>3"-12 UN-2B MACHINED THREADS</p>	<p>19 22 312</p>	<p><i>Concept I</i> HVTT Replacement Cap, with gasket, 3" thread</p>	<p>Yellow</p>	<p>1048175</p>
 <p>2 7/8"-12 UN-2B MACHINED THREADS</p>	<p>19 22 484</p>	<p><i>Concept II</i> HVTT Replacement Cap, with gasket, 2 7/8" thread</p>	<p>Yellow</p>	<p>1048177</p>

* **Note:** Dimensions are approximate.

End of Appendices

REPAIRS

December 1, 2020

REPR 2.1 Compression Couplings

1.0 Purpose

This document addresses the repair of various compression couplings and compression type joints, plus the related testing of such repairs, by Ameren Illinois (AIC).

2.0 Scope

This document addresses the following:

[3.0 Target Audience](#)

[4.0 General](#)

[5.0 Repair Methods for Below Grade Compression Couplings](#)

[6.0 Compression Joints on Steel Tees and Valves](#)

[7.0 Testing of Repairs](#)

[8.0 Records](#)

3.0 Target Audience

- Gas Engineering
- Gas Tech Engineering (GTE)
- Gas Integrity Management Personnel
- Gas Supervisors
- Gas Field Personnel
- Gas Field Personnel - Welders
- Gas Tech Services (GTS) Supervisors
- Gas Tech Services (GTS) Technicians
- Gas Construction Services Supervisors
- Contract Gas Construction Company Supervisors
- Contract Construction Inspectors
- Contract Welding Inspectors

4.0 General

- 4.1 Leaking compression couplings may leak or fail due to pull out of pipe or leakage through the elastomer seal between coupling and pipe.
- 4.2 Pull out of the pipe may be caused by 3rd party damage, thermo cycling, soil stresses, or soil shifting associated with ground movement.
- 4.3 The elastomer seal leakage may be the result of material degradation of the seal or misaligned pipe segments.
- 4.4 This procedure outlines the approved *methods for repairing* below grade leaking compression couplings on both mains and service lines, plus compression joints on tees and valves installed in mains. No new compression couplings are permitted for below ground service. See [POLY 2.6, Section 7.0](#).

5.0 Repair Methods for Below Grade Compression Couplings

The following repair procedures apply to *both mains and service lines unless otherwise noted*:

- 5.1 Plastic-to-Plastic

UNCONTROLLED IF PRINTED

5.1.1 Remove compression coupling, AND

5.1.2 Replace with a new section of pipe connected by an approved fusion procedure.

5.2 Plastic-to-Steel

5.2.1 For main:

1. Remove compression coupling, AND
2. Replace with a plastic-to-steel transition fitting that is welded to the steel and fused to the plastic pipe with approved procedures.

5.2.2 For service line:

1. If the steel portion of the service line is isolated from the cathodic protection system, replace the service line.
2. If the service line is connected to a steel main with a compression coupling, remove the coupling and replace with a plastic-to-steel transition fitting that is welded to the steel and fused to the plastic pipe with approved procedures OR replace the service tee.

5.3 Steel-to-Steel

5.3.1 If the compression coupling is within 5 feet of a foundation wall:

1. Tighten and encapsulate the compression coupling with a full encirclement welded split sleeve, OR
2. Remove the coupling and replace with a new section of pipe connected by an approved welding procedure, OR
3. Replace the service line.

5.3.2 If the compression coupling is greater than 5 feet from a foundation wall, visually inspect for indications of the pipe pulling out of the coupling:

1. Wrap shows evidence of being stretched.
2. Pipe shows evidence of being pulled or is out of normal alignment with coupling.
3. Once wrap is removed, pipe next to coupling is cleaner or shinier than the rest of the pipe.

5.3.3 If pull out *is detected*:

1. Tighten and encapsulate the compression coupling with a full encirclement welded split sleeve at the time of the leak repair, OR
2. Remove the coupling and replace with a new section of pipe connected by an approved welding procedure, OR
3. Replace the service line.

5.3.4 If pull out *is not detected*:

1. Attempt to tighten compression coupling to repair leak, AND
2. Following repair by tightening, Gas Supervisor shall create a DOJM for work completion within 30 calendar days to either:
 - 2 a. Encapsulate the compression coupling with a full encirclement welded split sleeve,

- 2 b. Remove the coupling and replace with a new section of pipe connected by an approved welding procedure, OR
- 2 c. Replace the service line.

6.0 Compression Joints on Steel Tees and Valves

- 6.1 If the compression joint tee or valve is within 5 feet of a foundation wall:
 - 6.1.1 Replace the tee, OR
 - 6.1.2 If leak is eliminated, install a minimum of 2 welded straps across the joint, equally spaced around the joint (see [MAIN 2.3, Section 5.3](#)), AND
 - 6.1.3 Remove the tee or valve and replace with a new section of pipe, tee, or valve connected by an approved welding procedure, doing such *within 30 calendar days*.
- 6.2 If the compression joint tee or valve is *greater than 5 feet* from a foundation wall, visually inspect for pipe pull out from the compression joint.
 - 6.2.1 If pull out *is detected* (see [Paragraph 5.3.2](#) for indicators):
 1. Tighten the compression joint.
 2. If leak is eliminated, install minimum of 2 welded straps across the joint, equally spaced around the joint (see [MAIN 2.3, Section 5.3](#)), AND
 3. Schedule the replacement of compression tee or valve with a weld-in section of pipe and tee or valve.
 - 3 a. Gas Supervisor shall create a DOJM to replace the compression joint *within 30 calendar days*.
 4. If leak is not eliminated, replace the tee or valve with a section of pipe and tee or valve using an approved welding procedure.
 - 6.2.2 If pull out *is not detected*:
 1. Attempt to tighten the compression joint to eliminate leak.
 2. Following repair by tightening, the Gas Supervisor shall identify if that section of main is scheduled for replacement within the next 36 months as part of a coupled steel main replacement program.
 3. If replacement is not scheduled, the Gas Supervisor shall create a DOJM to replace the compression joint with a new section of pipe, tee, or valve connected by an approved welding procedure.
 - 3 a. The DOJM shall be completed within 30 calendar days.
 4. If leak is not eliminated, replace the tee or valve with a section of pipe and tee or valve using an approved welding procedure.

7.0 Testing of Repairs

- 7.1 All piping repairs must be inspected and tested in accordance with 49 CFR Part 192, Subpart J and to avoid a possible de-rating of the main and service line.
- 7.2 *Mains*: If necessary to replace a section of main, the replacement pipe shall be pre-tested (i.e., tested before installation or tied into the existing pipeline) to the pressure of a new main in the same location.

- 7.3 **Service Lines:** When a service line is physically disconnected from the supply source, the replaced portion, and the remaining portion of service line from disconnection point to the meter valve shall be pressure tested in the same manner as a new service line.
- 7.4 All tie-in welds, fusions, or mechanical fittings shall be visually inspected, and leak tested at the pipe operating pressure with leak detection fluid or leak detection instrument.

8.0 Records

- 8.1 Document the actual test pressure and test duration on the leak repair form within Click-Mobile.
- 8.2 Actual Pressure and test duration for main segments shall be recorded on the appropriate pressure test forms. See [PTST 1 Section 14](#). The completed form is to be placed in the job packet.
- 8.3 Maintain records addressing leak repairs AND pressure tests for life of the facility.
- 8.4 Record location of compression couplings that have been:
- 8.4.1 Repaired but not encapsulated.
 - 8.4.2 Strapped compression joint tees and valves.

End of Instructions.

Operator Qualification (OQ) Required?

YES

- 0641: Visually Inspect Pipe and Components Prior to Installation
- 0751: Joining of Plastic Pipe - Butt Heat Fusion: Manual
- 0781: Joining of Plastic Pipe - Electrofusion
- 0801: Welding
- 0811: Visual Inspection of Welding and Welds
- 0861: Installation of Steel Pipe in a Ditch
- 0901: Installation of Plastic Pipe in a Ditch
- 0981: Backfilling
- 0991: Coating Application and Repair - Brushed or Rolled
- 1011: External Coating Application and Repair - Wrapped
- 1041: Install Mechanical Clamps and Sleeves - Bolted

Appendices

NONE.

Attachments

NONE.

Compliance Requirements

49 CFR Part 192 Subpart G (specifically §§ 192.309 and 192.311), and Subpart M.

UNCONTROLLED IF PRINTED

Illinois Commerce Commission (ICC) Title 83: Public Utilities, Part 590, Minimum Safety Standards for Transportation of Gas and for Gas Pipeline Facilities, available online [here](#).

Reference Documents

[MAIN 2.3 Main Installation: Pull Out Prevention](#)

[POLY 2.6 Polyethylene Pipe: Mechanical Joining](#)

Document Rescission

REPR 2.01 Repair: Compression Couplings, October 15, 2018.

Revision Notes

Location of Changes	Summary of Changes
Not applicable.	This is a new document.

REPAIRS

December 15, 2021

REPR 2.2 Plidco Split+Sleeve

1.0 Purpose

This document addresses the use of split sleeves for steel pipe repair.

2.0 Scope

This document addresses the following:

[3.0 Target Audience](#)

[4.0 General](#)

[5.0 Material Storage](#)

[6.0 Installation](#)

[7.0 Seal Welding](#)

Appendices

[Appendix A - Plidco Split+Sleeve Reference and Dimensional Data](#)

[Appendix B - Torque Values for Studs/Nuts](#)

3.0 Target Audience

- Gas Engineering
- Gas Tech Engineering (GTE)
- Gas Integrity Management Personnel
- Gas Supervisors
- Gas Field Personnel
- Gas Field Personnel - Welders
- Gas Tech Services (GTS) Supervisors
- Gas Tech Services (GTS) Technicians
- Gas Construction Services Supervisors
- Contract Gas Construction Company Supervisors
- Contract Construction Inspectors
- Contract Welding Inspectors

4.0 General

- 4.1 The Plidco Split+Sleeve is suitable for pipe repair by bridging over leaks and other defects in the steel pipe, provided leakage can be safely controlled during necessary pipe surface preparation. See Figure 1.
- 4.2 This repair sleeve may be used for Make Safe and permanent repair of steel pipe.
- 4.3 Permanent repairs require the sleeve to be seal welded.

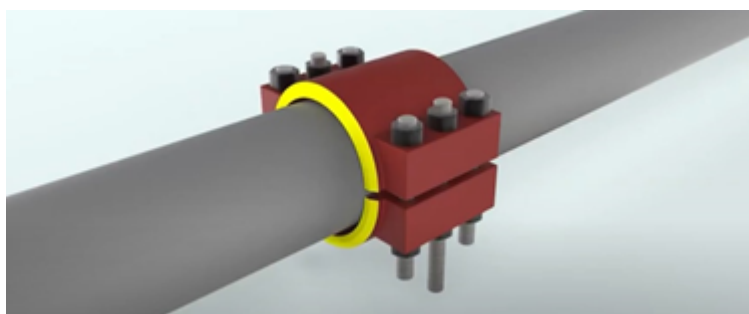

Figure 1: Plidco Split+Sleeve

UNCONTROLLED IF PRINTED

- 4.4 Seal welding shall be performed by an In-Service qualified welder using approved In-Service welding procedures. See [WELD 2.4, In-Service Welding](#).
- 4.5 For product and dimensional data, see [Appendix A](#).

5.0 Material Storage

- 5.1 Store Plidco Split+Sleeves in a dry environment to prevent the unpainted surfaces from rusting and at temperature not exceeding 120 °F.
- 5.2 Store fittings with a dark polyethylene cover to keep direct sunlight from the packing, thus, to protect seal material from becoming brittle and losing ability to seal.
- 5.3 It is recommended that elastomer seals, studs, nuts, screws, and/or threaded fasteners be coated with a heavy grease to prevent rusting and deterioration caused from environmental conditions (see Table 1 for compatibility to seal material).

Table 1: Compatibility of Greases on Seals

Seal Type	Petroleum Based Grease	Silicone Based Grease	Glycerine Based Grease	Super Lube® Grease
Aflas	✓	✓	✓	✓
Buna-N	✓	✓	✓	✓
Hycar	✓	✓	✓	✓
Kevlar	✓	✓	✓	✓
Neoprene		✓		✓
Silicone			✓	✓
Teflon	✓	✓	✓	✓
Viton	✓	✓	✓	✓

- 5.4 Table 2 indicates the shelf life of the different elastomer seals. The shelf life will vary with the precautions taken to protect the seals as specified above.

Table 2: Shelf Life of Seals

Type Seal	Shelf Life
Buna-N & Hycar	up to 5 years
Neoprene	up to 10 years
Aflas, Silicone, & Viton	up to 20 years

6.0 Installation

- 6.1 Remove all coating, rust, and scale from the pipe surface where the Split + Sleeve will be installed. The cleaner (i.e., smoother) the surface under the seal, the more positive it will seal. Installation will proceed faster with lower bolt stress required to seal. The seal can tolerate minor surface irregularities up to ± 1/32 inch.
- 6.2 See manufacturer's installations instructions in [REPR 3](#).
- 6.3 Handle seals and "girder rings" carefully so not to damage. Lifting devices such as chains, cables, or lift truck forks should not contact the seals or rings. Contact can result in the seals being pulled from their grooves.

- 6.4 Coat all exposed seal surfaces with a heavy grease that is compatible. See [Table 1](#). This will allow the circumferential packing to slide around the pipe instead of binding during the tightening process.
- 6.5 Clean and lubricate all studs and nuts with a high-grade graphite oil thread lubricant, or a light-weight machine oil. Before installation, check that nuts moves freely and easily.

Excessive lubrication may contaminate weld.

- 6.6 Install sleeve as follows:
 - 6.6.1 Assemble the fitting halves loosely around the pipe to one side of the leak and matching the yellow painted ends of the fitting.
 - 6.6.2 Slide the loose assembly over the leak or defect being careful not to damage the girding or packing.
 - 6.6.3 Center the fitting over the damaged area, as much as possible, and hand tighten the nuts on the studs.
 - 6.6.4 Uniformly torque all studs and nuts as specified in [Appendix B](#). For best results, maintain an equal gap all around between side bars while tightening bolts.
- 6.7 Recheck all studs for the recommended torque.
- 6.8 Gap in the side bars is approximately 1/8 inch when the sleeve is fully tightened.
- 6.9 Strap fitting if piping is partially or completely unrestrained to prevent pullout. See [MAIN 2.3](#) for strapping requirements.
- 6.10 Leak test by pressurizing the piping; do not exceed the maximum working pressure.
- 6.11 Resume normal operations. Re-pressurize the pipe slowly and steadily without surges that could vibrate the pipeline and fitting.

7.0 Seal Welding

- 7.1 Use approved welding procedure for seal welding. For in-service welding, see [WELD 2.4](#). Also, see Figure 2 for sketch.

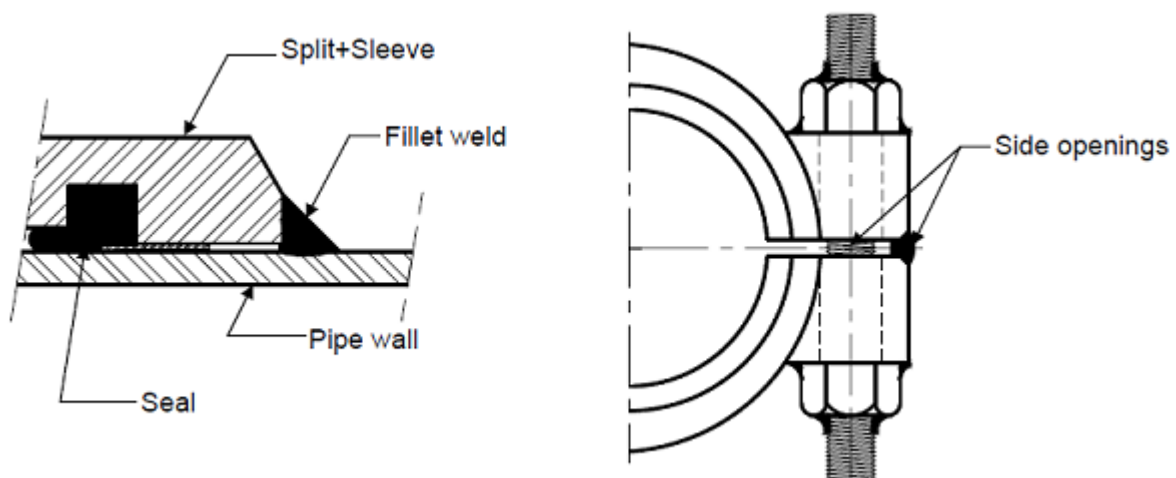

Figure 2: Seal Welding the Split+Sleeve

- 7.2 Use dry low-hydrogen electrodes for seal welding due to their resistance to moisture pick-up and hydrogen cracking.

- 7.3 Carefully control the size and shape of the circumferential fillet welds. Size should be at least 1.4 times wall thickness of the pipe.
 - 7.3.1 Strive for a concave faced fillet weld, with streamlined blending into both members. Avoid notches and undercuts. The smoother and more streamlined the weld, the greater the resistance to fatigue failure.
 - 7.3.2 The worst possible shape is a heavy reinforced convex weld with an undercut. Improper weld shape can lead to rapid fatigue failure which can cause leakage or rupture.
- 7.4 Shielded metal arc welding (SMAW) filler metals listed in API Std 1104 include the cellulose coated electrodes (E-XX10 series) which are typically preferred because of excellent downhill welding characteristics. **Cellulose coated electrodes (E-XX10) are not recommended for seal welding the studs and nuts.**

Use caution so welding does not overheat the seals.

- 7.5 Monitor the heat generated by welding or preheating, particularly near the area of the seals.
 - 7.5.1 Monitor temperature by using temperature crayons or probe thermometers (direct reading or infrared).
 - 7.5.2 Sequence the welding so that heat is not concentrated in one area.
 - 7.5.3 If the heat generated approaches the temperature limit of the seal material which is indicated on the label, then:
 - 1. Sequence the welding to another part of the fitting so that the affected area has a chance to cool, OR
 - 2. Discontinue welding.
- 7.6 Re-torque the studs and nuts periodically during field welding because weld contraction will cause them to loosen.
- 7.7 Seal weld the studs (Grade B-7) of the Plidco Split+Sleeve. This is more difficult welding since the studs are made of AISI 4140 steel (high carbon equivalence).
 - 7.7.1 Use low hydrogen electrodes (E-XX18) and a modest preheat (do not exceed 200 °F) to reduce hydrogen cracking and pin holes.
 - 7.7.2 The preheat will dry out any moisture, oil dampness, or thread lubricant that may be present in the seal weld area.
- 7.8 Seal weld the sleeve per the following sequence:
 - 7.8.1 Fillet weld the ends of sleeve to pipe.
 - 7.8.2 Seal weld side openings on fitting.
 - 7.8.3 Re-torque studs and nuts.
 - 7.8.4 Seal weld around bottom of nuts to side bar of fitting.
 - 7.8.5 Seal weld nuts to studs.

End of Instructions.

UNCONTROLLED IF PRINTED

Operator Qualification (OQ) Required?

YES

0641: Visually Inspect Pipe and Components Prior to Installation

0801: Welding

0811: Visual Inspection of Welding and Welds

1041: Install Mechanical Clamps and Sleeves - Bolted

1051: Fit-Up of Weld Type Repair Sleeve

Appendices

[Appendix A - Plidco Split+Sleeve Reference and Dimensional Data](#)

[Appendix B - Torque Values for Studs/Nuts](#)

Attachments

NONE.

Compliance Requirements

49 CFR Part 192 - Transportation of Natural and Other Gas by Pipeline: Minimum Federal Safety Standards, specifically Subpart E, Welding of Steel in Pipelines

API Std 1104, Welding of Pipelines and Related Facilities, including Appendix B (Latest edition incorporated by reference within 49 CFR Part 192)

Illinois Commerce Commission (ICC) Title 83: Public Utilities, Part 590, Minimum Safety Standards for Transportation of Gas and for Gas Pipeline Facilities, available online [here](#).

Reference Documents

[MAIN 2.3 Main Installation: Pull-Out Prevention](#)

[REPR 3 Repair: Forms and Reference Materials](#)

[WELD 2.4 Welding: In-Service Welding](#)

Document Rescission

REPR 2.2 Repairs – Plidco Split+Sleeve, October 1, 2021

Revision Notes

Location of Changes	Summary of Changes
Appendix A-4 – Alternate 2	Removed 10" x 10 ½", 1,000 psig split+sleeve with Buna-N Packing

Appendix A - Plidco Split+Sleeve Reference and Dimensional Data

A-1. Drawings for Dimensional Reference

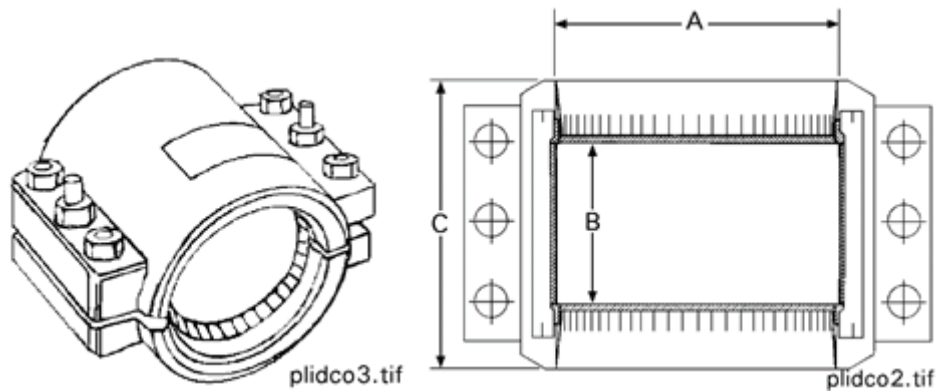

A-2. Plidco Split+Sleeve - Basic Unit

Nominal Pipe Size (inches)	AIC Stock No.	Inside Diameter "A" (inches)	Inside Length "B" (inches)	Overall Length "C" (inches)	Approx. Weight (lbs.)	Rating (psig)	Plidco Part No.
2	19 33 435	3-1/8	5-3/4	9	23	1,000	RSS0-0200SP w/ 1" vent (SS0-0200C)
3	19 33 447	4	5-1/4	8-1/2	34	1,000	RSS0-0300SP w/ 1-1/2" vent (SS0-0300C)
4	19 33 456	5	5-1/4	8-1/2	42	1,000	RSS0-0400SP w/ 2" vent (SS0-0400C)
6	19 33 477	7-1/8	5-1/4	9	62	1,000	RSS0-0600SP w/ 2" vent (SS0-0600C)
7	19 33 480	7-1/2	5-1/4	10	120	1,000	RSS0-0700SP w/ 2" vent (SS0-0700C)
8	19 33 487	9-1/8	5-1/4	10	125	1,000	RSS0-0800SP w/ 2" vent (SS0-0800C)
10	19 33 497	11-1/4	5-1/2	10-1/2	147	1,000	RSS0-1000SP w/ 2" vent, hinged (SS0-1000HC)
12	19 33 506	13-1/4	5-1/2	10-1/2	230	1,000	w/ 2" vent, hinged (SS0-1200HC)
14	19 33 513	14-1/2	8	14	385	1,000	RSS01400SP w/ 2" vent, hinged (SS0-1400HC)
16	19 33 522	16-1/2	8	14	420	1,000	RSS01600SP w/ 2" vent, hinged (SS0-1600HC)
18	19 33 526	18-1/2	8	14	555	1,000	RSS01800SP w/ 2" vent, hinged (SS0-1800HC)

A-3. Plidco Split+Sleeve - Alternate 1

With 2" Save-A-Valve nipple vent, anodic bolts, and silicone packing							
Nominal Pipe Size (inches)	AIC Stock No.	Inside Diameter "A" (inches)	Inside Length "B" (inches)	Overall Length "C" (inches)	Approx. Weight (lbs.)	Rating (psig)	Plidco Part No.

3	19 01 143	4	5-1/4	8-1/2	34	1,000	SS0-0300SSAVANODIC
4	19 01 144	5	5-1/4	8-1/2	42	1,000	SS0-0400SSAVANODIC
4	19 01 202	5	18	24	145	1,000	SS0-040024SSAVANODIC
10	19 01 264	11-1/4	18	24	410	1,000	SS0-100024SSAVANODIC
12	19 01 268	13-1/4	5-1/2	10-1/2	230	1,000	SS0-1200SSAVANODIC
12	19 01 308	13-1/4	18	24	550	1,000	SS0-120024SSAVANODIC

A-4. Plidco Split+Sleeve - Alternate 2

With Buna-N Packing							
Nominal Pipe Size (inches)	AIC Stock No.	Inside Diameter "A" (inches)	Inside Length "B" (inches)	Overall Length "C" (inches)	Approx. Weight (lbs.)	Rating (psig)	Plidco Part No.
2	19 23 509	3-1/8	5-3/4	8-1/2	23	1,000	SS0-0200
3	19 23 517	4	5-1/4	8-1/2	34	1,000	SS0-0300
8	19 23 546	9-1/8	5-1/4	10	125	1,000	SS0-0800

Appendix B - Torque Values for Studs/Nuts

Nominal Stud Diameter (inches)	Wrench Opening (inches)	0.08 COF Torque (ft lbs.)	0.15 COF Torque (ft lbs.)
5/8	1-1/16	33	56
3/4	1-1/4	57	98
7/8	1-7/16	91	156
1	1-5/8	135	233
1-1/8	1-13/16	197	342
1-1/4	2	274	480
1-3/8	2-3/16	370	651
1-1/2	2-3/8	485	857
1-5/8	2-9/16	617	1,096
1-3/4	2-3/4	782	1,394
1-7/8	2-15/16	968	1,730
2	3-1/8	1,180	2,116
1-1/4	3-1/2	1,695	3,053
2-1/2	3-7/8	2,340	4,231

B-1. Notes for Table:

1. Studs are ASTM A 193 Grade B7.
2. Nuts are ASTM A 194 Grade 2H.
3. Torque values shown in table represent 2 different coefficients of friction (COF), 0.08 and 0.15. It is assumed that studs & nuts are clean, free running, free of obvious sur-

face flaws, and lubricated. The 0.08 COF assumes studs have been lubricated with a high-grade graphite-oil thread lubricant. The 0.15 COF assumes that studs have been lubricated with a light-weight machine oil. Torque values are safe minimums and represent approximately 25,000 psi bolt pre-stress.

End of Appendices

REPAIRS

December 15, 2021

REPR 2.3 Leaking Aldyl-A Tapping Tee Caps

1.0 Purpose

This document addresses the material, tooling, and installation instructions for repairing the original caps on leaking DuPont Aldyl-A tapping tee.

2.0 Scope

This document addresses the following:

[3.0 Target Audience](#)

[4.0 General](#)

[5.0 Repair Kit Components](#)

[6.0 Tools](#)

3.0 Target Audience

- Superintendent Technical Training - Operations
- Superintendent Technical Training -- Welding
- Gas Training Supervisors
- Operator Qualification Personnel
- Quality Assurance Personnel
- Gas Standards & Procedures Personnel
- Gas Engineering
- Gas Integrity Management Personnel
- Gas Supervisors
- Gas Field Personnel
- Gas Construction Services Supervisors
- Contract Gas Construction Company Supervisors
- Contract Construction Inspectors
- Contract Welding Inspectors

4.0 General

- 4.1 This procedure uses the Kerotest electrofusion repair kit to repair leaking DuPont Aldyl-A tapping tee caps.
- 4.2 DuPont manufactured a standard and non-standard tapping tee in which the stack diameters were different. The standard tees had a stack diameter of 1.67 inches and the non-standard tee had a diameter of 1.57 inches.
- 4.3 Repair kits are stocked for both stack sizes.
- 4.4 Installation instructions are in [POLY 2.5](#) Electrofusion.

5.0 Repair Kit Components

- 5.1 Each Kerotest repair kit is packaged in a sealed polyethylene bag and includes the following components:

- Innogaz Electrofusion Coupling
- Insert, Repair Fitting
- Plug, Repair fitting
- O-ring Seal, Repair Fitting



- 5.2 The repair kit for the standard tapping tees (Stock No. 19 72 134) uses a 1.25-inch IPS electrofusion coupling and insert.
- 5.3 The repair kit for the non-standard tapping tees (Stock No. 19 72 153) uses a 40-mm electrofusion coupling and insert.

6.0 Tools

6.1 The following tool is required for installing the Kerotest repair kit.

6.1.1 125 Scraper/Peeler with handles, for use with standard tees (Part No. 88416226).

6.1.2 40M Scraper/Peeler with handles, for use with non-standard tees (Part No. 88410040).



6.1.3 Insert Holding Tool (Part No. 72770524).



Operator Qualification (OQ) Required?

YES

0641: Visually Inspect Pipe and Components Prior to Installation

0781: Joining of Plastic Pipe - Electrofusion

0981: Backfilling

Appendices

NONE.

Attachments

UNCONTROLLED IF PRINTED

NONE.

Compliance Requirements

49 CFR Part 192, specifically §192.703

Illinois Commerce Commission (ICC) Title 83: Public Utilities, Part 590, Minimum Safety Standards for Transportation of Gas and for Gas Pipeline Facilities, available online [here](#).

Reference Documents

[POLY 2.5 Polyethylene Pipe: Electrofusion](#)

Document Rescission

REPR 2.3 Repairs: Leaking Aldyl-A Tapping Tee Caps, October 1, 2020.

Revision Notes

Location of Changes	Summary of Changes
2.0 Scope	Removed Section 7.0 Installation Instructions. Move to POLY 2.5 Electrofusion
Subsection 4.4	Added: Installation instructions are in POLY 2.5 Electrofusion.
Subsection 5.2	Removed reference to Section 7.0
Section 7.0 Installation Instructions	Removed and moved to POLY 2.5 Electrofusion, Section 11.0

REPAIRS

April 1, 2023

REPR 3 Forms and Reference Materials

Click on the links below to open the documents.

References

1. [CSNRI Clock Spring Coil Pass Method Installation Guide and Checklist](#)
2. [CSNRI Clock Spring Filler & Adhesive Update](#)
3. [CSNRI Clock Spring Product Sheet](#)
4. [CSNRI A+ Wrap Product Sheet](#)
5. [Clock Spring Underwater Installation Guide](#)
6. [Plidco Split + Sleeve Installation](#)
Also available online [here](#).
7. [Plidco Storage and Inspection Instructions](#)
8. [Syntho Glass XT Engineering Assessment Form](#)
9. [Syntho Glass XT Installation Guide](#)
10. [OmegaWrap Installation Procedure](#)

End of Section.

Document Rescission

REPR 4 Repairs: Forms and Reference Materials, December 1, 2020.

Revision Notes

Location of Changes	Summary of Changes
Reference Materials	Updated: CSNRI Clock Spring Coil Pass Installation Guide and Checklist CSNRI Clock Spring Product Sheet Added – CSNRI A+ Wrap Product Sheet CSNRI Clock Spring Filler & Adhesive Update OmegaWrap Installation Procedures

REGS-Regulator Stations

REGULATOR STATIONS

October 1, 2020

REGS 0 Table of Contents

[REGS 1 Regulator Stations: Requirements](#)

Section 1.0 Purpose

Section 2.0 Scope

Section 3.0 Target Audience

Section 4.0 Regulator Station Inspection Schedule

Section 5.0 Regulator Station Engineering Evaluations

Section 6.0 Records

Operator Qualifications (OQ)

Compliance Requirements

Reference Documents

Document Rescission

[REGS 2.1 Regulator Stations: Regulator Station Inspections](#)

Section 1.0 Purpose

Section 2.0 Scope

Section 3.0 Target Audience

Section 4.0 General

Section 5.0 Available Resources or Equipment

Section 6.0 Operational Inspection

Section 7.0 Primary Inspection

Section 8.0 Acoustical Inspection

Section 9.0 Atmospheric Corrosion Inspection

Section 10.0 Gas Leakage Inspection

Section 11.0 Gas Regulator Station Signage

Operator Qualifications (OQ)

Compliance Requirements

Reference Documents

Document Rescission

[REGS 2.2 Regulator Stations: Bypass Operations](#)

UNCONTROLLED IF PRINTED

Section 1.0 Purpose

Section 2.0 Scope

Section 3.0 Target Audience

Section 4.0 General

Section 5.0 Bypass Operation

Operator Qualifications (OQ)

Appendices

Appendix A - Gas Regulator Station Schematic

Compliance Requirements

Reference Documents

Document Rescission

REGS 2.3 Regulator Stations: Troubleshooting Common Regulator Problems

Section 1.0 Purpose

Section 2.0 Scope

Section 3.0 Target Audience

Section 4.0 General

Section 5.0 Common Causes of Regulator Failure

Section 6.0 Blowing Relief Valve

Section 7.0 Low System Pressure

Section 8.0 Before Leaving the Regulator Station

Operator Qualifications (OQ)

Compliance Requirements

Reference Documents

Document Rescission

REGS 2.4 Regulator Stations: Gas Heaters

Section 1.0 Purpose

Section 2.0 Scope

Section 3.0 Target Audience

Section 4.0 General

Section 5.0 Types of Heaters

Section 6.0 Indirect Heaters

Section 7.0 Catalytic Heaters

Operator Qualifications (OQ)

Appendices

Appendix A - Antifreeze Requirements

UNCONTROLLED IF PRINTED

Compliance Requirements

Reference Documents

Document Rescission

REGS 3 Regulator Stations: Regulator Station Design

Section 1.0 Purpose

Section 2.0 Scope

Section 3.0 Target Audience

Section 4.0 General

Section 5.0 General Guidelines and Requirements

Section 6.0 Standardized Design Features

Section 7.0 Standard Regulator Station Drawings

Operator Qualifications (OQ)

Appendices

Appendix A - Regulator Station Specifications

Compliance Requirements

Reference Documents

Document Rescission

REGS 4 Regulator Stations: Forms and Reference Materials

References

Document Rescission

End Table of Contents.

Document Rescission

REGS 4 Regulator Stations: Forms and Reference Materials, January 1, 2018.

Revision Notes

Location of Changes	Summary of Changes
Not applicable.	This is a new document.

REGULATOR STATIONS

October 1, 2021

REGS 1 Requirements

1.0 Purpose

This procedure describes the requirements for regulator station inspections, engineering evaluations, and associated records. This procedure complies with 49 CFR §§ 192.201, 192.740, and 192.743.

2.0 Scope

This document addresses the following:

[3.0 Target Audience](#)[4.0 Regulator Station Inspection Schedule](#)[5.0 Regulator Station Engineering Evaluations](#)[6.0 Records](#)**3.0 Target Audience**

- Gas Engineer
- Gas Field Personnel
- Gas Supervisor
- Gas Tech Services (GTS) Supervisor
- Gas Tech Engineering (GTE)

4.0 Regulator Station Inspection Schedule

- 4.1 Each regulator station shall have an inspection once each calendar year not to exceed 15 months.
- 4.1.1 The Supervisor Gas Tech Services or Gas Supervisor is responsible for ensuring the annual inspection is completed.
- 4.1.2 The inspection shall include an operational inspection of the station facilities.
- 4.2 All regulator stations that serve more than approximately 250 customers shall, at a minimum, receive a primary inspection during the 10th calendar year (see [REGS 2.1](#)). The primary inspection should be performed while conducting the operational inspection.
- 4.3 At the discretion of the Supervisor Gas Tech Services or Gas Supervisor, a regulator station can be identified to have a primary inspection on a more frequent interval of 1 or 5 years.
- 4.4 The Supervisor Gas Tech Services or Gas Supervisor shall consider the following operational conditions when identifying regulator stations that warrant a more frequent inspection.
- 4.4.1 Regulator bodies subjected to erosive service conditions.
- 4.4.2 Construction and hydrostatic testing upstream of the regulator station.
- 4.4.3 Abnormal changes in operating conditions or unusual flows/velocities.
- 4.4.4 Abnormal pressures imposed on regulator or flow devices.

5.0 Regulator Station Engineering Evaluations

UNCONTROLLED IF PRINTED

- 5.1 Engineering shall perform an evaluation of each regulator station once each calendar year not exceeding 15 months.
- 5.2 The Gas Tech Engineering or Gas Engineer is responsible for ensuring the evaluation is performed.
- 5.3 The engineering evaluation verifies that the station relief valve capacity is sufficient to provide adequate overpressure protection.
 - 5.3.1 If the station relief valve capacity is insufficient, a new or additional relief device must be installed to provide sufficient capacity.
 - 5.3.2 In addition, any change to the regulator station equipment require an engineering evaluation to be performed.

6.0 Records

- 6.1 Maintain all regulator station equipment data, inspection information, and engineering evaluation history in Maximo.
- 6.2 Retain all information for the life of the regulator station.

End of Instructions.

Operator Qualification (OQ) Required?

YES

0221: Inspect Test and Maintain Sensing Devices

0231: Inspect Test and Maintain Programmable Logic Controllers

0301: Manually Opening and Closing Valves

0311: Adjust and Monitor Flow or Pressure - Manual Valve Operation

0321: Valve Corrective Maintenance

0331: Valve - Visual Inspection and Partial Operation

0341: Valve - Preventive Maintenance

0351: Pneumatic Actuator/Operator Inspection and Testing, Preventative and Corrective Maintenance

0361: Electric Actuator/Operator Inspection and Testing, Preventative and Corrective Maintenance

0371: Hydraulic Actuator/Operator Inspection and Testing, Preventative and Corrective Maintenance

0381: Spring Loaded Pressure Regulating Device - Inspection and Testing, Preventative and Corrective Maintenance

0391: Pilot - Operated Pressure Regulating Device - Inspection and Testing, Preventative and Corrective Maintenance

0401: Controller Type Pressure Regulating Device - Inspection and Testing, Preventative and Corrective Maintenance

0411: Spring Loaded Pressure Limiting and Relief Device - Inspection and Testing, Preventative and Corrective Maintenance

UNCONTROLLED IF PRINTED

0421: Pilot-Operated Pressure Limiting and Relief Device - Inspection and Testing, Preventive and Corrective Maintenance

0431: Pneumatic Loaded Pressure Limiting and Relief Device - Inspection and Testing, Preventive and Corrective Maintenance

Appendices

NONE.

Attachments

NONE.

Compliance Requirements

49 CFR §192.201 Required Capacity of pressure relieving and limiting stations.

49 CFR § 192.740 Pressure regulating, limiting and overpressure protection - Individual service lines directly connected to production, gathering, or transmission pipelines.

49 CFR § 192.743 Pressure limiting and regulating stations: Capacity of relief devices.

Reference Documents

[REG 2.1 Regulator Stations: Regulator Station Inspections](#)

Document Rescission

REGS 1 Regulator Stations: Requirements, October 1, 2020.

Revision Notes

Location of Changes	Summary of Changes
5.0 – Engineering Evaluations	Removed 5.4 – Calculations can be performed manually or by using evaluation function in Maximo.

REGULATOR STATIONS

October 1, 2021

REGS 2.1 Regulator Station Inspections

1.0 Purpose

This procedure provides the minimum requirements for the inspection of Ameren Illinois (AIC) gas regulator stations. This procedure is in compliance with 49 CFR §§ 192.740 and 192.743.

2.0 Scope

This document addresses the following:

[3.0 Target Audience](#)

[4.0 General](#)

[5.0 Resources or Equipment](#)

[6.0 Operational Inspection](#)

[7.0 Primary Inspection](#)

[8.0 Acoustical Inspection](#)

[9.0 Atmospheric Corrosion Inspection](#)

[10.0 Gas Leakage Inspection](#)

[11.0 Gas Regulator Station Signage](#)

3.0 Target Audience

- Gas Engineer
- Gas Field Personnel
- Gas Supervisor
- Gas Tech Services (GTS) Supervisor
- Gas Tech Engineering (GTE)
- Gas Control

4.0 General

- 4.1 Each regulator station is scheduled for an annual inspection. See [REGS 1](#).
- 4.2 Annual inspection requires, at a minimum, an Operational Inspection which:
- 4.2.1 Ensures that each regulator is:
1. In good mechanical condition.
 2. Set to control at the correct pressures at or below the MAOP.
- 4.2.2 Verifies that the equipment is operating properly.
- 4.2.3 Verifies the overpressure protection equipment (OPP) activates at the equipment set point that is in ClickMobile/Maximo.
- 4.2.4 Identify and schedule any repairs that are needed.

Operational Inspections do not require the disassembly of regulators or OPP equipment.

UNCONTROLLED IF PRINTED

- 4.3 The Gas Technical Service (GTS) Technician, at their discretion, may conduct a Primary Inspection with the Operational Inspection.
- 4.4 Use ClickMobile as a guide when performing inspections for each station.
- 4.5 GTS Technician responsible for performing regulator station inspection at regulator stations equipped with SCADA or an Electronic Pressure Recorder (ERX), shall contact Gas Control:
 - 4.5.1 Prior to beginning inspection so Gas Control is aware of the work being performed.
 - 4.5.2 After completing the inspection and before leaving the site to verify SCADA and/or ERX have returned to normal operation.
- 4.6 Document the Operational and Primary Inspections in ClickMobile.

5.0 Resources or Equipment

- 5.1 The following shall be available, as needed, to perform the inspection:
 - 5.1.1 Combustible gas indicator.
 - 5.1.2 Test gauge, of sufficient range to display station maximum inlet pressure, for measuring downstream pressure.
 - 5.1.3 Manufacturer's instruction manual for each regulator and OPP equipment.
 - 5.1.4 O&M Manual
 - 5.1.5 PPE & Safety Equipment

6.0 Operational Inspection

- 6.1 Visual Inspection
 - 6.1.1 Upon arriving at the station site verify:
 - 1. Area is secure.
 - 1 a. Fence gates are locked, if station is inside a fenced area.
 - 1 b. Building doors are locked, if station is inside a building.
 - 1 c. Critical valves are tamper resistant, if station is in open area.
 - 2. Appropriate signage/line markers are:
 - 2 a. In place.
 - 2 b. Legible.
 - 2 c. Contain accurate information such as company name and phone number.
 - 2 d. See [PMRK 2](#) for further information.
 - 6.1.2 Perform a visual assessment of all equipment or devices that are critical to safety, gas delivery, and system reliability.
 - 1. Anomalies and abnormalities discovered during the visual assessment shall be immediately repaired or reported.
- 6.2 Valve Operation.
 - 6.2.1 Remove existing locking or security devices on valves necessary for performing station inspection.

6.2.2 During the station inspection ensure valves are:

1. Accessible.
2. Visually identified.
3. Operable.
4. Valve operators are in correct position.

6.2.3 Exercise valves to the extent necessary to verify proper operations:

1. Station inlet, outlet, and bypass valves
2. Overpressure protection equipment isolation valves
3. Control, sensing, and supply line valves.

6.3 Regulator Station with Relief Valve.

6.3.1 Check regulator station equipment for leaks before and after inspection.

1. A leak investigation shall be initiated within ClickMobile and is required for all leaks found during annual station inspection.

6.3.2 Install pressure gauge where needed to verify and monitor system pressure during the inspection.

6.3.3 Verify regulators and relief valve installed at the station matches the equipment listed in Maximo.

6.3.4 Confirm pressure settings indicated within Maximo.

6.3.5 Any discrepancy in equipment or changes that are made to the documented pressure settings shall be verified with the GTS Supervisor and indicated on the inspection form within ClickMobile.

6.3.6 Check operation of regulator

1. While performing the Operational Inspection, stations with parallel runs shall have one run verified as operational and available at all times, unless there are multiple feeds or other options that can maintain adequate system pressure.
2. The following inspection shall be performed on each station regulator run:
 - 2 a. Close the outlet valve to the station or station run, where applicable.
 - (i) Take care to monitor the outlet system pressure and if necessary operate bypass valves to maintain adequate system pressure. See [REGS 2.2](#).
 - 2 b. Use test gauge to:
 - (i) Verify set point.
 - (ii) Verify regulator lock-up, if designed to do so.
 - (iii) Verify pressure settings with a test gauge or calibrating test gauge. See [METR 2.4](#).
 - 2 c. Verify regulator is in good working order:
 - (i) Controls pressure at set point.
 - (ii) Operates properly.

UNCONTROLLED IF PRINTED

(iii) Locks-up below the gas system MAOP.

2 d. If Operational Inspection does not confirm acceptable operation, then perform a Primary Inspection of the regulator. See [Section 7.0](#).

2 e. After the regulator passes inspection, return regulator to service.

6.3.7 Check the relief valve set point

1. GTS Technician shall monitor the downstream pressure gauge while the relief valve is taken out of service to ensure downstream system pressure does not exceed MAOP.
2. Install Test Gauge where needed to monitor the pressure at which the relief valve activates.
3. Ensure the relief valve's isolation valve is closed.
4. Test for the correct relief set point by applying gas pressure or nitrogen to the test connection.
5. Monitor the test gauge and verify the set point where:
 - 5 a. The direct operated relief valve moves off seat.
 - 5 b. The pilot operated relief valve begins to bleed from the pilot.
6. Verify relief valve is in good working order:
 - 6 a. Relieves at set point.
 - 6 b. Operates properly.
 - 6 c. Confirm main valve moves off seat.
7. If acceptable operation is not obtained during the Operational Inspection, then perform an internal inspection of the relief valve.
8. Remove gas pressure or nitrogen from the test connection, open the relief valve's isolation valve and verify the relief valve closes and stops relieving.
9. Verify that vent stacks are clear and unobstructed.
10. Verify that rain caps are in place and operating freely.
11. Verify the isolation valve to the relief valve is in the open position and locked, secured or operator removed to prevent unauthorized operation.

6.3.8 Final Inspection

1. If pressure monitoring devices are installed on the station, verify the correct pressures are being registered.
2. Verify all valves are in the correct position for normal operation.
3. Verify bypass valves are closed, isolation valve to the relief valve is open and the valves are locked, secured or operator removed to prevent unauthorized operation.

Heater by-pass valves may be left open or closed seasonally. These valves should be verified for correct seasonally position during final inspection. Refer to [REGS 2.4](#) Heaters

- 3 a. In lieu of locking devices, control line valve operator handles can be removed to prevent unauthorized operation.
4. Document within ClickMobile the maintenance work performed or that needs to be scheduled.
5. Ensure required signage is properly displayed and tags denoting set pressures are installed, where needed.
6. Make final check
7. Secure access to fenced area or buildings surrounding the station to prevent unauthorized entry.

6.4 Passive Monitor Regulator Station (both upstream and downstream).

- 6.4.1 Regulator station equipment should be checked for leaks before and after inspection.
 1. A leak investigation shall be initiated within ClickMobile and is required for all leaks found during annual station inspection.
- 6.4.2 Install pressure gauge where needed to verify and monitor system pressure during the inspection.
- 6.4.3 Verify regulator and monitor installed at the station matches the equipment listed in Maximo.
- 6.4.4 Confirm pressure settings indicated within Maximo.
- 6.4.5 Any discrepancy noted in equipment or any changes made to documented pressure settings should be verified with the GTS Supervisor and indicated on the inspection form within ClickMobile.
- 6.4.6 Check operation of the "working" regulator.
 1. While performing the Operational Inspection, stations with parallel runs shall have one run verified as operational and available at all times, unless there are multiple feeds or other options that can maintain adequate system pressure.
 2. Perform the following inspection on each station regulator:
 - 2 a. Close the outlet valve to the regulator station or station run, where applicable.
 - (i) Care shall be taken to monitor the outlet system pressure and, if necessary, operate bypass valves to maintain adequate system pressure. See [REGS 2.2](#).
 - 2 b. Use test gauge to:
 - (i) Verify set point.
 - (ii) Verify regulator lock-up, if designed to do so.
 - (iii) Verify pressure settings with a test gauge or calibrating test gauge. See [METR 2.4](#).
 - 2 c. Verify "working" regulator is in good working order:
 - (i) Controls pressure at set point.
 - (ii) Operates properly.

UNCONTROLLED IF PRINTED

(iii) Locks-up below the gas system's MAOP.

2 d. If Operational Inspection does not confirm acceptable operation, then perform a Primary Inspection of the regulator. See [Section 7.0](#).

6.4.7 Check the operation of the "monitor" regulator.

1. While performing the Operational Inspection, stations with parallel runs shall have one run verified as operational and available at all times, unless there are multiple feeds or other options that can maintain adequate system pressure.
2. Use test gauge to verify the pressure at which the "monitor" regulator assumes control and achieves lock-up.
3. Verify "monitor" regulator is in good working order:
 - 3 a. Controls pressure at set point.
 - 3 b. Operates properly.
 - 3 c. Locks-up below the gas system Maximum Emergency Pressure (MEP).
4. If acceptable operation is not determined during the Operational Inspection, a Primary Inspection of the "monitor" regulator should be performed

6.4.8 Return regulator station to normal operation.

6.4.9 Final Inspection. See [6.3.8](#).

6.5 Working Monitor Regulator Station.

6.5.1 Check regulator station for leaks before and after inspection.

1. A leak investigation shall be initiated within ClickMobile and is required for all leaks found during annual station inspection.

6.5.2 Install pressure gauge where needed to verify and monitor system pressure during the inspection.

6.5.3 Confirm pressure settings indicated within Maximo.

6.5.4 Any discrepancy noted in equipment or any changes made to documented pressure settings should be verified with the GTS Supervisor and indicated on the inspection form within ClickMobile.

6.5.5 Check the operation of the first and second cut regulators.

1. While performing the Operational Inspection, stations with parallel runs shall have one run verified as operational and available at all times, unless there are multiple feeds or other options that can maintain adequate system pressure.
2. Close the outlet valve to the regulator station/station run, where applicable.
3. Take care to monitor the outlet system pressure and, if necessary, operate bypass valves to maintain adequate system pressure. See [REGS 2.2](#).
4. Use test gauge to verify the pressure where the first and second cut regulators lock-up.
5. Verify pressure settings with a test gauge or calibrating test gauge. See [METR 2.4](#).
6. Verify first and second cut regulators are in good working order:

UNCONTROLLED IF PRINTED

- 6 a. Controls pressure at set point
- 6 b. Operates properly
- 6 c. Lock-up below the gas system's MAOP
- 7. If Operational Inspection does not confirm acceptable operation, then perform a Primary Inspection of the regulator. See [Section 7.0](#).
- 6.5.6 Check the operation of the "monitor pilot" on the first cut regulator.
 - 1. Use test gauge and record the pressure the "monitor pilot":
 - 1 a. Controls pressure at set point
 - 1 b. Operates properly
 - 1 c. Lock-up below the gas system MEP
 - 2. If Operational Inspection does not confirm acceptable operation, then perform a Primary Inspection of the regulator. See [Section 7.0](#).
- 6.5.7 Return regulator station to normal operation.
- 6.5.8 Final Inspection. See [6.3.8](#).
- 6.5.9 Use this same inspection on all regulator runs.

7.0 Primary Inspection

- 7.1 When required, a Primary Inspection will be performed in conjunction with the Operational Inspection.
- 7.2 In addition to following the Operational Inspection procedures in [Section 6.0](#), a Primary Inspection will involve examination of the internal components of the regulator.
- 7.3 Isolate the regulator requiring an internal inspection.
 - 7.3.1 Take care to monitor the outlet system pressure and if necessary operate bypass valves to maintain adequate system pressure.
 - 7.3.2 Safely vent gas in the isolated segment to atmosphere.
 - 7.3.3 Examine the regulator for:
 - 1. Obstructions
 - 2. Liquids
 - 3. Debris
 - 4. Damage to internal components
 - 7.3.4 Examine the pilot supply filter; clean, and replace as needed.
 - 7.3.5 Examine the regulator components and install replacement parts as needed.
 - 7.3.6 Diaphragm cases may be disassembled as part of the Primary Inspection.
- 7.4 Follow recommended manufacturer start-up procedures and check for proper operations.
 - 7.4.1 Regulator takes control of the flow of gas.
 - 7.4.2 Regulator demonstrates proper lock-up as required by Operational Inspection.
- 7.5 Set the regulator to the set-point identified within Maximo.

UNCONTROLLED IF PRINTED

- 7.6 Check station filters, drips, strainers, and knock-out drums for reliable service. This may include opening or other techniques.
- 7.7 Final Inspection. See [6.3.8](#).

8.0 Acoustical Inspection

An acoustical inspection is the verification of regulator function by lowering the regulator set point until noise from the regulator becomes inaudible, thus indicating no flow or shutoff. **This should not be confused with monitoring the noise level of the regulator station.**

- 8.1 A station not designed to accommodate or support an Operational or Primary regulator station inspection shall require Acoustical Inspection.
- 8.2 Install pressure gauges where needed then lower the set point of the regulator being inspected until the flow through the regulator becomes inaudible and the downstream test gauge indicates a steady or decreasing delivery pressure.
 - 8.2.1 This will verify that the regulator is locked-up and that the regulator will control the flow of gas to meet downstream demand below the gas system MAOP.
- 8.3 If the Acoustical Inspection does not confirm acceptable operation, then perform a Primary Inspection of the regulator. See [Section 7.0](#).
- 8.4 Notify supervision if a planned outage is required due to a failed acoustical test.
 - 8.4.1 A plan for an outage or other supply options shall be evaluated.
 - 8.4.2 System affected shall be manned and pressure monitored at all times until regulator performance is corrected and station is returned to normal service.

9.0 Atmospheric Corrosion Inspection

- 9.1 Check the above-grade station piping and equipment for atmospheric corrosion.
- 9.2 See [CORR 1](#) for detailed information on Atmospheric Corrosion evaluation.
- 9.3 Check for disbonded coating on the risers and piping.
- 9.4 Document on the ClickMobile inspection form whether or not atmospheric corrosion or disbonded coating is found on above-grade piping.

10.0 Gas Leakage Inspection

- 10.1 Check the regulator station for the presence of gas by sampling the atmosphere surrounding the station, station piping, equipment vents, and the outlet of relief valve vent stacks. See [LEAK 2.6](#).
 - 10.1.1 Stations located within a fenced area: Station piping includes all above-grade and below-grade piping within the fence.
 - 10.1.2 Stations outside of fenced area: Station piping is referred to as above-grade. Above-grade piping is all piping above the pipe to soil interface.
 - 10.1.3 Exposed piping and equipment inside pits and vaults will be leak surveyed in accordance with [LEAK 2.6](#).

10.2 Use leak classification and verification methods in accordance with procedures in [LEAK 1](#).

10.3 Documentation of leak survey results is dependent on Class Location of the station:

10.3.1 For fenced stations in a Class 1 or Class 2 location: Document on the ClickMobile pressure control station inspection form.

10.3.2 For fenced stations in a Class 3 location, Bi-annual (twice per year) leak surveys are issued through Maximo and should be documented within ClickMobile. See [LEAK 2.6](#).

10.4 Any below-grade gas leak that is identified during the inspection shall be documented within ClickMobile by initiating a leak investigation or completing a leak surveillance on an existing leak.

10.5 Above-grade Class 3 leaks repaired at the time of the inspection shall be documented within ClickMobile by initiating a leak investigation.

10.6 A separate leak investigation is required for an above-grade Class 1 leak identified during the inspection. See [LEAK 1](#).

11.0 Gas Regulator Station Signage

11.1 General

11.1.1 Gas regulator stations shall be properly identified with company name and phone number.

11.1.2 Gas regulator stations accessible to the public shall be identified with a pipeline marker or as sign shown in [PMRK 2](#).

11.1.3 Gas regulator stations not accessible to the public (locked fence or enclosure) shall be identified with the following signs, installed on the regulator station fence or enclosure:

1. Danger sign indicating company name and phone number
 - 1 a. Stock Number 16-02-285 shown in 11.2 OR
 - 1 b. Stock Number 16-02-605 shown in [PMRK 2 Appendix B-2](#).

11.2 Danger Sign



Stock No. 16 02 285

UNCONTROLLED IF PRINTED

This will remain a valid sign posted at regulator stations and does not need to be changed until the condition dictates replacement. Once the current supply of signs is depleted, the sign shown below will be the replacement stock.



Stock No. 16 02 285

New sign that will be available after existing supply of current sign, shown above, is depleted.

End of Instructions.

Operator Qualification (OQ) Required?

YES

0221: Inspect Test and Maintain Sensing Devices

0231: Inspect Test and Maintain Programmable Logic Controllers

0301: Manually Opening and Closing Valves

0311: Adjust and Monitor Flow or Pressure - Manual Valve Operation

0321: Valve Corrective Maintenance

0331: Valve - Visual Inspection and Partial Operation

0341: Valve - Preventive Maintenance

0351: Pneumatic Actuator/Operator Inspection and Testing, Preventative and Corrective Maintenance

0361: Electric Actuator/Operator Inspection and Testing, Preventative and Corrective Maintenance

0371: Hydraulic Actuator/Operator Inspection and Testing, Preventative and Corrective Maintenance

0381: Spring Loaded Pressure Regulating Device - Inspection and Testing, Preventive and Corrective Maintenance

UNCONTROLLED IF PRINTED

039: Pilot - Operated Pressure Regulating Device - Inspection and Testing, Preventive and Corrective Maintenance

0401: Controller Type Pressure Regulating Device - Inspection and Testing, Preventive and Corrective Maintenance

0411: Spring Loaded Pressure Limiting and Relief Device - Inspection and Testing, Preventive and Corrective Maintenance

0421: Pilot-Operated Pressure Limiting and Relief Device - Inspection and Testing, Preventive and Corrective Maintenance

0431: Pneumatic Loaded Pressure Limiting and Relief Device - Inspection and Testing, Preventive and Corrective Maintenance

1371: Operate Gas Pipeline – System Control Center Operations

1381: Operate Gas Pipeline – Local Facility Remote Control Operations

Appendices

NONE.

Attachments

NONE.

Compliance Requirements

49 CFR §192.201 Required capacity of pressure relieving and limiting stations.

49 CFR §192.740 Pressure regulating, limiting and overpressure protection - Individual service lines directly connected to production, gathering, or transmission pipelines.

49 CFR §192.743 Pressure limiting and regulating stations: Capacity of relief devices.

Reference Documents

[CORR 1 Corrosion Control: Requirements](#)

[LEAK 1 Leak Management: Requirements](#)

[LEAK 2.6 Leak Management: Walking Leak Surveys](#)

[METR 2.6 Metering: Pressure Gauges](#)

[PMRK 2 Pipeline Markers: Pipeline Facility Markers](#)

[REGS 2.2 Regulator Stations: Bypass Operations](#)

Document Rescission

REGS 2.1 Regulator Station Inspections, October 1, 2020

Revision Notes

Location of Changes	Summary of Changes
Target Audience	Added Gas Control
Paragraph 6.2.1	Expanded – Remove existing locking or security devices on valve.

<p>Paragraph 6.3.7 - Item 11</p>	<p>Revised – Verify the isolation valve to the relief valve is in the open position and locked, secured or operator removed to prevent unauthorized operation.</p>
<p>Paragraph 6.3.8 – Item 3</p>	<p>Revised– Verify bypass valves are closed, isolation valve to the relief valve is open and the valves are locked, secured or operator removed to prevent unauthorized operation.</p> <p>Added NOTE: Heater by-pass valves may be left open or closed seasonally. These valves should be verified for correct seasonally position during final inspection. Refer to <u>REGS 2.4</u> Heaters</p>
<p>Operator Qualifications</p>	<p>Added:</p> <p>1371 Operate Gas Pipeline – System Control Center Operations</p> <p>1381 Operate Gas Pipeline – Local Facility Remote Control Operations</p>

1.0 Purpose

This procedure provides guidelines for bypassing a gas regulator station through a bypass valve.

2.0 Scope

This document addresses the following:

[3.0 Target Audience](#)

[4.0 General](#)

[5.0 Bypass Operation](#)

Appendices

[Appendix A - Gas Regulator Station Schematic](#)

3.0 Target Audience

- Gas Engineer
- Gas Field Personnel
- Gas Supervisor
- Gas Tech Services (GTS) Supervisor
- Gas Tech Engineering (GTE)
- Gas Control

4.0 General

- 4.1 Gas Control shall be included in the planning and execution of the bypass operation if the affected system is remotely monitored.

The improper bypassing of these pressure regulators exposes the distribution system to pressures that may exceed the MAOP, and can cause catastrophic pipeline failures, which could result in the loss of property and/or life.

Properly installed and operating pressure regulators are designed to hold system pressure at or below the established MAOP.

- 4.2 Because it is a complex procedure, comprehensive planning and careful execution are required when bypassing pressure regulators.
- 4.3 If time allows, prepare a written plan and consider the following:
- 4.3.1 Identify the maximum and minimum pressures allowed on both the downstream and upstream piping.
- 4.3.2 The bypass of regulators feeding a distribution system with an MAOP of 14 inches w.c. or less is strictly prohibited, unless a properly-sized over pressure protection device, such as relief valve, remains active.

UNCONTROLLED IF PRINTED

- 4.3.3 Review the regulator station design and ensure that all drawings are accurate and correct.
- 4.3.4 Note other regulator stations that may also feed the downstream distribution system and be familiar with their operations. **Know where they are located.**
- 4.3.5 Consider lowering upstream pressures to the MAOP of the downstream pipe.
- 4.3.6 Field-identify all emergency valves and their location that would be used should an emergency situation develop as a result of the bypass operation.
- 4.3.7 Make sure 2 gauges are appropriately placed to measure actual upstream and downstream pipeline pressures without being isolated by valves during the actual bypass operation. Refer to [Appendix A](#).
- 4.3.8 During unregulated bypass operation, a minimum of 2 gas field personnel should be present at all times while performing station maintenance or operational/primary inspections.
- 4.3.9 Develop specific instructions for the gas field personnel performing the bypass operation.

5.0 Bypass Operation

- 5.1 The Gas Supervisor or GTS Technician shall be responsible for reviewing the bypass plan with the gas field personnel.
- 5.2 Assign one individual (bypass operator) to operate the bypass valve and to monitor the installed pressure gauges.
 - 5.2.1 The bypass operator shall remain at the bypass valve throughout the procedure and continuously monitor the system pressure.

If bypass operator needs to leave the site contact supervisor for replacement and remain at the site until replacement arrives.

- 5.3 Install the pressure gauges used to monitor upstream and downstream pressures.
 - 5.3.1 These gauges must be in good condition, verified for accuracy, and not be isolated by a valve during the actual bypass operation.
 - 5.3.2 Ensure the pressure tap valve is in open position and gauge is showing the correct pressure.
 - 5.3.3 These gauges should be visible at all times by the bypass operator responsible for operating the bypass valve.
- 5.4 The system pressure shall be maintained between the established maximum and minimum limits.
- 5.5 Locate and operate the valves that will be used in the bypass procedure.
- 5.6 Place the bypass valve in operation. Allow the system to stabilize before starting work on the regulator.
- 5.7 If at any time during the bypass operation, the bypass operator cannot maintain the pressure within the prescribed limits, the GTS Technician or gas field personnel assigned to the bypass operation shall:
 - 5.7.1 Place the regulator back in operation and return the system to normal operation.

UNCONTROLLED IF PRINTED

1. If it is not possible to return the system to normal operation, the GTS Technician or gas field personnel shall:
 - 1 a. Turn off gas to the system
 - 1 b. Immediately notify the Gas Supervisor or GTS Supervisor of the emergency.
 2. If a pipeline emergency has been declared, then the Emergency Plan shall be implemented.
- 5.8 After completing the work, return the regulator station to normal operation.
- 5.8.1 Ensure that the bypass valve is closed and locked.
 - 5.8.2 The GTS Technician or gas field personnel shall observe the regulator station operation to ensure that all equipment is properly operating and that the equipment set points are correct.
- 5.9 If Gas Control was involved in monitoring the operation, GTS Technician shall contact them to verify that operating parameters have been returned to normal operations.

End of Instructions.

Operator Qualification (OQ) Required?

YES

0301: Manually Opening and Closing Valves

0311: Adjust and Monitor Flow or Pressure - Manual Valve Operation

0331: Valve - Visual Inspection and Partial Operation

0341: Valve - Preventive Maintenance

1371: Operate Gas Pipeline – System Control Center Operations

Appendices

[Appendix A - Gas Regulator Station Schematic](#)

Attachments

NONE.

Compliance Requirements

NONE.

Reference Documents

NONE.

Document Rescission

REGS 2.2 Regulator Stations: Bypass Operations, October 1, 2020

Revision Notes

Location of Changes	Summary of Changes
---------------------	--------------------

Target Audience	Added Gas Control
Operator Qualifications	Added – 1371 – System Control Center Operations

Appendix A - Gas Regulator Station Schematic

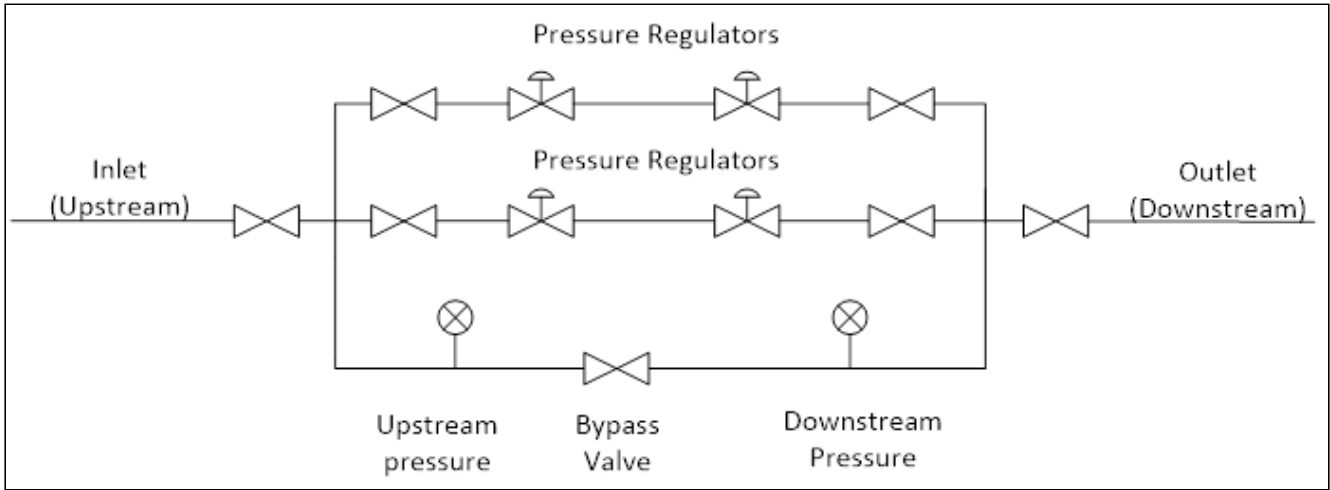

REGULATOR STATIONS

October 1, 2021

REGS 2.3 Troubleshooting Common Regulator Problems**1.0 Purpose**

This procedure provides guidance in troubleshooting gas regulator and relief valve problems.

2.0 Scope

This document addresses the following:

[3.0 Target Audience](#)[4.0 General](#)[5.0 Common Causes of Regulator Failure](#)[6.0 Blowing Relief Valve](#)[7.0 Low System Pressure](#)[8.0 Before Leaving the Regulator Station](#)**3.0 Target Audience**

- Gas Engineer
- Gas Field Personnel
- Gas Supervisor
- Gas Tech Services (GTS) Supervisor
- Gas Tech Engineering (GTE)

4.0 General

- 4.1 This section contains guidelines that could be used to determine possible regulator problems.
- 4.2 To troubleshoot a regulator station, personnel need to know the following:
- 4.2.1 Normal operating pressure,
- 4.2.2 Maximum allowable operating pressure (MAOP) of the system,
- 4.2.3 Maximum emergency pressure (MEP) of the system,
- 4.2.4 Number of feeds into the system,
- 4.2.5 Proper equipment pressure settings for the regulator station.
- 4.3 MAOP and MEP are defined in Table 1 and 49 CFR §192.201.

Table 1 MAOP and MEP

Pressure Class	System MAOP	Maximum Emergency Pressure (MEP)
Low Pressure	4" w.c. to 14" w.c.	27.6 w.c.
Distribution Pressure 1	1 PSIG to 12 psig	MAOP + 50%
Distribution Pressure 2	12 PSIG to 60 psig	MAOP + 6 psig
High Pressure Distribution & Transmission	Over 60 psig	MAOP + 10% or 75% SMYS whichever is lower.

- 4.4 When a relief valve has been taken out of service, or when using an unregulated bypass, the system pressure shall be continuously monitored.

UNCONTROLLED IF PRINTED

- 4.4.1 The pressure should be maintained at or below the MAOP of the system and shall be maintained below the system MEP.

5.0 Common Causes of Regulator Failure

5.1 Regulator body:

- 5.1.1 Dirt

- 5.1.2 Weld slag

- 5.1.3 Distillates

- 5.1.4 Other debris

- 5.1.5 Orifices or valve seats that are not properly secured inside the regulator body

5.2 Valves worn from debris passing through the regulator.

5.3 Orifices or valve seats nicked, cracked, or worn by debris.

5.4 Moisture inside the diaphragm case (generally caused by flooding or condensation) can freeze, preventing the regulator from controlling the pressure.

This condition can cause an above or below normal pressure situation.

5.5 Ruptured diaphragm in regulator.

This situation can cause gas to exhaust through the vent on the diaphragm case.

5.6 Vents plugged by insects, mud, or other foreign matter.

5.7 Damaged or torn elastomeric element (found in boot type regulators).

6.0 Blowing Relief Valve

6.1 **DO NOT** shut off the valve to the relief valve until proper steps have been followed as outlined below.

6.2 Check the pressure with the appropriate pressure indicating gauges to verify the operating pressure on the system.

6.2.1 If the pressure is at normal operating pressure, the blowing relief valve may be faulty.

1. SLOWLY close the valve on the inlet side of the relief valve, while watching the pressure gauge on the system to be certain over-pressurization of the system does not occur.

- 1 a. Immediately reopen the valve if the system pressure increases and shows no sign of leveling off at a pressure below the MAOP.

- 1 b. Close the valve in the relief valve pilot sensing line, if necessary, to isolate the relief valve.

UNCONTROLLED IF PRINTED

2. Continuously monitor the system pressure shall be by observing the pressure indicating gauges while the relief valve is out of service.
 3. After the relief isolation valve has been closed and the relief valve has stopped blowing, re-pressurize the relief valve through the test tee using nitrogen or natural gas. This is to determine the relief valve set point and to clear any debris that may be caught under the seat.
 - 3 a. If the relief valve now appears to be operating satisfactorily, slowly crack open the isolation valve ahead of the relief.
 - 3 b. If the relief valve operation is satisfactory, fully open the isolation valve.
 - 3 c. If the relief valve operation is not satisfactory, the relief valve shall be repaired or replaced before putting the station back into service.
 4. After repairs, the relief valve can be returned to service.
 - 4 a. Slowly crack open the isolation valve ahead of the relief.
 - 4 b. Remember to lock this valve in an open position before leaving the station.
- 6.2.2 Check the regulator if the pressure is above normal operating pressure. Check the system to determine if it is served by multiple regulator stations.

DO NOT close the relief shutoff valve.

1. An overpressure condition exists if the pressure exceeds the system MEP.
 - 1 a. In the event that the system pressure has exceeded the MEP, the Gas Supervisor will immediately contact Gas Compliance.
2. If the regulator station contains more than one run:
 - 2 a. Install pressure gauges in the intermediate and the downstream system.
 - 2 b. Verify which runs are feeding gas.
 - 2 c. Slowly close the primary run inlet valve while observing the outlet system pressure, noting if the relief closes and the outlet pressure decreases to the correct system pressure or secondary set point.
 - 2 d. Verify correct operation of the secondary run before proceeding with repairs.
 - 2 e. Shut-in the primary run by closing the outlet valve (inlet valve is already closed), depressurize, and proceed with regulator repairs.
 - 2 f. After repairs are completed, return primary run to service by following the manufacturers recommended procedure.
 - 2 g. Raise the set point of primary run to appropriate system set point, ensuring that it has taken control back from the secondary run and that the secondary run is no longer feeding.
 - (i) If secondary run is not a full capacity secondary run, system pressures shall be monitored to prevent a low pressure situation.

UNCONTROLLED IF PRINTED

3. If the regulator station has single regulator run and is the only source of gas to the system:
 - 3 a. Using the bypass valve.
 - (i) Slowly open the bypass valve until a slight pressure increase is seen.
 - (ii) Slowly close the inlet valve to the regulator, watching the pressure gauge closely to make sure the bypass is holding the pressure near the normal system operating pressure.
 - (iii) This process may require opening of the bypass valve more on an unregulated bypass, as the inlet valve to the regulator is being closed.
 - 3 b. Follow procedures in [REGS 2.2](#) during bypass operations.
 - 3 c. After the inlet valve has been closed, observe the station operation to ensure proper pressure is maintained through the bypass.
 - (i) The relief valve should stop blowing as the pressure in the system returns to normal.
 - (ii) Close the regulator outlet valve.
 - (iii) After the regulator outlet valve is closed, shut off the control line.
 - (iv) The isolated section can then be depressurized and the regulator repaired or replaced.
4. System with more than one regulator station feeding:

The regulator station where the relief valve is blowing may not be the problem. It could be any of the regulators in the system causing the problem.

- 4 a. Begin at the station where the relief valve is blowing.
 - (i) Slowly close the regulator inlet valve while watching the pressure indicating gauges.
 - (ii) If the pressure does not decrease as valve is closed, the problem is likely to be a different regulator.
 - (iii) Slowly reopen the regulator inlet valve.
 - (iv) Check the other regulators in the same pressure system in a similar fashion until the faulty regulator is found.
- 4 b. After the faulty regulator is found, proceed to close the regulator inlet valve slowly, watching the pressure gauge closely to ensure that other regulators in the system can maintain an acceptable pressure level.
 - (i) If the system does not stabilize at an acceptable pressure, the bypass provision may have to be used while repairs are being made.

There may be other portions of the system that are experiencing a lower pressure than is seen at the station.

- (ii) If it is necessary to bypass the station, slowly crack open the bypass valve to stabilize the pressure near the normal system operating pressure.
- 4 c. Follow procedures in [REGS 2.2](#) during bypass operations.
- 4 d. After the regulator inlet valve has been closed, observe the station operation to be sure an acceptable pressure is maintained through the bypass, then:
 - (i) Shut off the regulator outlet valve.
 - (ii) After the outlet valve is closed, shut off the regulator control line, **if equipped**.
 - (iii) The isolated section of piping can be depressurized and the regulator can be repaired or replaced.
- 6.2.3 After repairs have been made to the regulator, return the regulator to service by following the manufacturer's recommended procedure.
 - 1. When opening a valve do it slowly.
 - 2. If a bypass has been used, slowly close the bypass valve while watching the pressure indicating gauges to make sure the regulator operates correctly.
 - 3. After the bypass is closed, adjust the regulator to the proper operating pressure.
- 6.2.4 If the relief valve was blowing at another location, recheck the relief valve to ensure that it has reseated properly after the system pressure has been returned to normal.

7.0 Low System Pressure

- 7.1 Check the inlet and outlet pressure at the regulator station, with pressure indicating gauges, to verify the problem is at the regulator station and not a problem elsewhere.

A pressure of 2 psig on a distribution system or 2" w.c. at the outlet of a customer's meter is considered the minimum allowable pressure, short of interrupting service.

- 7.2 Follow procedures in [EMER 2.4.9](#) "Low Pressure Situation" for situations involving low pressure or complete loss of pressure.
- 7.3 If the inlet pressure is near normal, try to adjust the regulator to increase the outlet pressure.
 - 7.3.1 Observe the inlet pressure gauge to make sure the inlet pressure does not drop off during this operation.
 - 7.3.2 Verify operation of secondary run (if present) by raising secondary set point to bring secondary run into operation.

UNCONTROLLED IF PRINTED

- 7.3.3 If the pressure cannot be raised in this manner, the bypass may have to be operated to increase the outlet pressure to temporarily eliminate the low pressure problem, provided the inlet pressure is sufficient.
- 7.4 Follow procedures in [REGS 2.2](#) during bypass operations.
- 7.5 During this bypass operation, the regulator may be inspected for proper operation.
- 7.6 If the inlet pressure to the regulator is lower than it should be, the capacity of the regulator may be affected.
 - 7.6.1 If present, verify operation of secondary run.

Secondary run may provide enough additional gas to temporarily eliminate the low pressure problem.

- 7.6.2 Operating the bypass may temporarily eliminate the low pressure problem, provided the inlet pressure is high enough to allow gas to pass through the bypass.
 - 7.6.3 Observe the inlet pressure indicating gauge to make sure the inlet pressure does not drop off during this operation.
- 7.7 Gather and record all operating pressures (inlet and outlet), flow conditions, temperatures, etc. for use in permanently correcting the situation.
- 7.8 Contact Gas Tech Service's Supervisor, Gas Engineering, or Gas Tech Engineering if equipment replacement, system flow study, or station rebuild is required.

8.0 Before Leaving the Regulator Station

- 8.1 Before leaving the regulator station, make sure it is secure and back to normal operation.
 - 8.1.1 Verify regulator shutoff and that the set pressure is correct.
 - 8.1.2 Verify station inlet and outlet valves are open.
 - 8.1.3 Verify bypass valves are closed and secured.
 - 8.1.4 Verify control line valves are open and secured.
 - 8.1.5 Verify outlet pressure is correct for the system.
 - 8.1.6 Verify the relief valve is on, set pressure is correct and the isolation valve is open, locked, secured or operator removed to prevent unauthorized operation.

End of Instructions.

Operator Qualification (OQ) Required?

YES

- 0301: Manually Opening and Closing Valves
- 0311: Adjust and Monitor Flow or Pressure - Manual Valve Operation
- 0321: Valve Corrective Maintenance
- 0331: Valve - Visual Inspection and Partial Operation
- 0341: Valve - Preventive Maintenance

UNCONTROLLED IF PRINTED

0351: Pneumatic Actuator/Operator Inspection and Testing, Preventive and Corrective Maintenance.

0361: Electric Actuator/Operator Inspection and Testing, Preventive and Corrective Maintenance.

0371: Hydraulic Actuator/Operator Inspection and Testing, Preventive and Corrective Maintenance.

0381: Spring Loaded Pressure Regulating Device - Inspection and Testing, Preventive and Corrective Maintenance

0391: Pilot-Operated Pressure Regulating Device - Inspection and Testing, Preventive and Corrective Maintenance

0401: Controller Type Pressure Regulating Device - Inspection and Testing, Preventive and Corrective Maintenance

0411: Spring Loaded Pressure Limiting and Relief Device - Inspection and Testing, Preventive and Corrective Maintenance

0421: Pilot-Operated Pressure Limiting and Relief Device - Inspection and Testing, Preventive and Corrective Maintenance

0431: Pneumatic Loaded Pressure Limiting and Relief Device - Inspection and Testing, Preventive and Corrective Maintenance

Appendices

NONE.

Attachments

NONE.

Compliance Requirements

49 CFR §192.201 Required capacity of pressure relieving and limiting stations.

Reference Documents

[EMER 2.4.9 Emergency Plan: Gas Field Personnel - Low Pressure Situation](#)

[REGS 2.2 Regulator Stations: Bypass Operations](#)

Document Rescission

REGS 2.3 Regulator Stations: Troubleshooting Common Regulator Problems, October 1, 2020.

Revision Notes

Location of Changes	Summary of Changes
Paragraph 8.1.6	Verify the relief valve is on, set pressure is correct and the isolation valve is open, locked, secured or operator removed to prevent unauthorized operation.

1.0 Purpose

This procedure provides guidance in operating, maintaining, and trouble-shooting indirect and catalytic heaters.

2.0 Scope

This document addresses the following:

[3.0 Target Audience](#)

[4.0 General](#)

[5.0 Types of Heaters](#)

[6.0 Indirect Heaters](#)

[7.0 Catalytic Heaters](#)

Appendices

[Appendix A - Antifreeze Requirements](#)

3.0 Target Audience

- Gas Field Personnel
- Gas Supervisor
- Gas Tech Services (GTS) Technicians
- Gas Tech Services (GTS) Supervisors

4.0 General

- 4.1 Cold temperatures, along with high humidity, accentuate the problems caused by external freezing, and by equipment failures or line shutoff due to freeze-up.
- 4.2 Internal gas freezing can cause regulator valves to freeze and stop up pilot lines causing loss of flow through the regulator station.
- 4.3 Pilot-loaded gas regulators are highly vulnerable to internal freeze-up in pilot valves.
 - 4.3.1 When pilot gas is taken from the main gas stream, regulated in one or more stages, it becomes much colder than before regulation and can cause previously vaporized liquids in the gas stream to fall out in the form of free liquids.
 - 4.3.2 The additional throttling within the pilot valve itself can cause the valve to freeze internally.
- 4.4 The moisture content of gas can exceed the 7 lb./MMCF contract limit if dehydration equipment fails OR if a line has been placed in service after being tested with water as a test medium.
 - 4.4.1 The addition of an inhibitor, such as methanol, may be needed on a temporary basis to minimize the possibility of hydrate (ice) formation and stoppage of the regulators or gas lines. See Figure 1.



Figure 1: Pipeline hydrates

- 4.5 For every 100 psi pressure differential across a regulator station there is approximately a 7 °F drop in gas temperatures or 1 °F temperature drop per atmosphere (14-15 psig) of pressure drop.
- 4.5.1 Minimum gas temperatures encountered in gas systems during cold weather may be as low as 35 °F.
- 4.5.2 Hydrates (ice) may form in the gas stream under various combinations of:
1. Pressure
 2. Pressure drop
 3. Gas temperature
 4. Moisture content of the gas.
- 4.5.3 Hydrates may form at temperatures above 32 °F.
- 4.5.4 External ice formation on piping and valves may also form because of excessive gas cooling caused by the cooling effect of the gas expansion.

5.0 Types of Heaters

- 5.1 When hydrates form under normal operating conditions, consider using either an indirect heating system or catalytic type heater.
- 5.2 Indirect heater is used where large volumes of gas passes through the regulator station.

Water bath type indirect heater is used to heat the entire gas stream before the gas is regulated.

- 5.3 Catalytic type heater is used, where gas flow is not great and regulators are relatively small or pilot loaded, to heat the equipment externally area. Avoid preheating the entire gas stream in small stations.

6.0 Indirect Heaters

- 6.1 General
- 6.1.1 Indirect heaters are water bath type natural gas heaters.
- 6.1.2 These indirect heaters are generally used at town border stations (city gate), delivery stations (sales point), or for industrial customers where larger volumes of gas move through the station.

- 6.1.3 Indirect heaters preheat the entire gas stream before regulation to keep the final temperature after regulation above 32 °F, or even up to 50 °F for internal hydrate control.
- 6.1.4 Expansion tanks should be installed on heaters to keep coils covered with antifreeze/water solution at all times.

6.2 Operation

- 6.2.1 Fuel gas is burned within the horizontal "U" shaped fire box immersed in the lower portion of the water bath. Heat released by the burning fuel gas is quickly transmitted through the firebox wall to the water bath. See Figure 2.

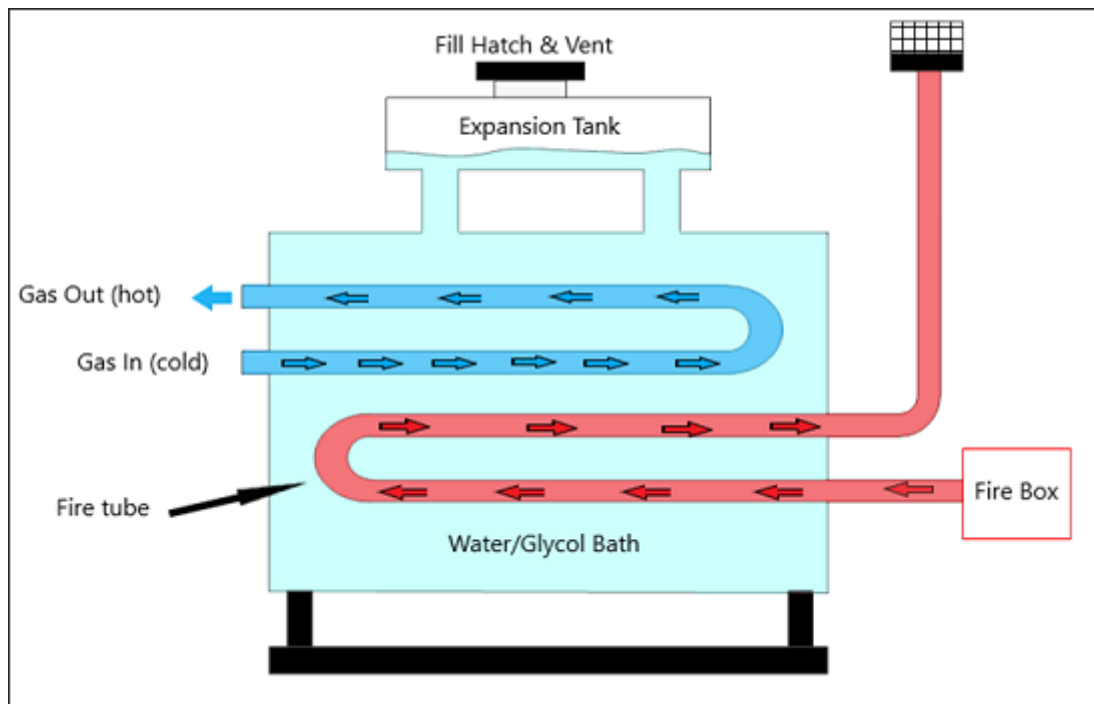

Figure 2: Indirect Water Bath Heater

- 6.2.2 The gas to be heated is directed through the process coil of the heater which is immersed in the upper portion of the water bath.
 - 1. Heat is transmitted from the hot water bath through the tube wall to the gas inside the flow coil.
- 6.2.3 The heater temperature controller maintains the water bath temperature at the desired level by controlling the fire box fuel gas supply.
 - 1. The optimum temperature of water bath is 140 °F.
 - 2. At temperatures above 160 °F, water loss can be expected to increase. Normal bath temperatures are 135 -140 °F.

6.3 Typical Spring Shutdown

- 6.3.1 Obtain small sample of glycol solution to be tested annually prior to shutdown.
- 6.3.2 Turn off main fuel supply valve so residual gas in the manifold will bleed off and burn.
- 6.3.3 Shut off pipeline heater that is not needed for summer time operation.
- 6.3.4 Where heater bypass provision exists:
 - 1. Open bypass valve to heater.

UNCONTROLLED IF PRINTED

2. Monitor downstream system pressure with pressure gauge.
3. Close inlet valve at heater so gas does not pass through heater coil.

6.4 Typical Fall Start-Up

- 6.4.1 Check and clean all other controls.
- 6.4.2 Check fire tube for rust and carbon buildup or damage.
- 6.4.3 Remove and clean flame arrestor and air inlets.
- 6.4.4 Remove burner and pilot from heater. Clean and inspect for damage. Replace main burner and/or pilot, if necessary (size orifice to burner). Replace thermocouple as required.
- 6.4.5 Check fluid levels and adjust as necessary after getting analysis back from the lab.
- 6.4.6 Clean and adjust mixing chamber for proper flame.
- 6.4.7 Check safety valve for proper operation and shutdown.
- 6.4.8 Check regulator burner valve for shut-off and operation. Set pressure.
- 6.4.9 Check setting and operation of thermostat control.
- 6.4.10 Check on/off operation.
- 6.4.11 Periodically check regulators and relief valves for proper operation
- 6.4.12 Check insulation skin cover. Maintain watertight from weather.
- 6.4.13 Check insulation condition and paint, as necessary.
- 6.4.14 Check and clean strainers or filters.
- 6.4.15 Check pressure gauge:
 1. Check accuracy of pressure gauges (deadweight, calibrating gauge).
 2. Remove and replace defective gauges.
- 6.4.16 Clean inside of fire tube, if necessary:
 1. Scrape tube and vacuum (If using a vacuum, ensure no gas is present).
 2. Check for leaks in fire tube.
- 6.4.17 Where heater bypass provision exists:
 1. Monitor downstream system pressure with pressure gauge.
 2. Open inlet valve at heater so gas passes through the heater coil.
 3. Verify heater outlet valve is in the open position and close bypass valve to heater.

6.5 Lighting Indirect Heaters (Typical)

- 6.5.1 Read the specific instructions for all valves and instruments before attempting to light an indirect heater.
- 6.5.2 Close the isolation valves ahead of the main burner and pilot.
- 6.5.3 Open the inlet valve to the fuel gas manifold and adjust the pressure regulators to provide manufacturer specified operating pressure to the main burner.
- 6.5.4 Before lighting, make sure main burner valve is closed.

UNCONTROLLED IF PRINTED

- 6.5.5 Turn on pilot valve if heater is equipped with thermocouple safety. Depress safety, light pilot, and hold safety for 45 seconds.
- 6.5.6 After pilot has remained lit, turn on main burner valve very slowly until fully opened
- 6.5.7 Set the thermostat at the normal temperature.

Never stand in front of the heater when lighting.

- 6.5.8 Regulate the primary air adjustment on the mixer to obtain a blue flame.

A yellow flame indicates insufficient air.

- 6.5.9 When there is more than one burner, adjust each burner sequentially. Repeat steps [6.5.4](#) through 6.5.8 if there is more than one fire tube.
- 6.5.10 When the desired water bath temperature is reached, adjust the thermostat until the control valve closes.

6.6 Typical Extended Maintenance

- 6.6.1 If performance and operation indicate unsatisfactory heater condition, it may be necessary to perform extended maintenance.
 - 1. When extended maintenance is advisable, it shall be scheduled as soon as practical but can be adjusted based on:
 - 1 a. Weather conditions.
 - 1 b. System operating conditions.
 - 1 c. Observable heater conditions.
 - 1 d. Heater performance.
 - 2. Extended maintenance can be performed on site or off site.
- 6.6.2 Extended maintenance may consist of the following:
 - 1. Fire tube removal and inspection.
 - 1 a. Remove fire tube from tank and check for corrosion and wall thickness pitting.
 - 2. Gas pressure bundle removal and inspection.
 - 2 a. Remove pressure coils from tank and check for corrosion and wall thickness pitting.
 - 3. Internal heater shell inspection.
 - 3 a. Check internal shell walls for corrosion and pitting.
 - 3 b. Check pressure coil and fire tube brace structure (beams, angle irons) for cracks or damaged and worn supports.
 - 4. Perform corrective action on any unacceptable items found.

7.0 Catalytic Heaters

7.1 General

- 7.1.1 Catalytic heaters may be used in hazardous areas to prevent failure of equipment due to both internal and external freeze-up.
- 7.1.2 They are light in weight, require little or no maintenance, and do not have moving parts to replace.
- 7.1.3 The catalytic heater is an option for eliminating equipment freeze-up problems by concentrating external heat upon the instruments and instrument piping without preheating the entire gas stream.
- 7.1.4 Catalytic heaters can be used on pilot regulators and supply lines to pilot operated regulators, and to directly heat self-operated regulator bodies.



Figure 3: Catalytic Heaters

7.2 Typical Operation

- 7.2.1 The catalytic heater is a flameless gas explosion-proof heater that produces radiant heat by the reaction of combustible gases with oxygen or air.

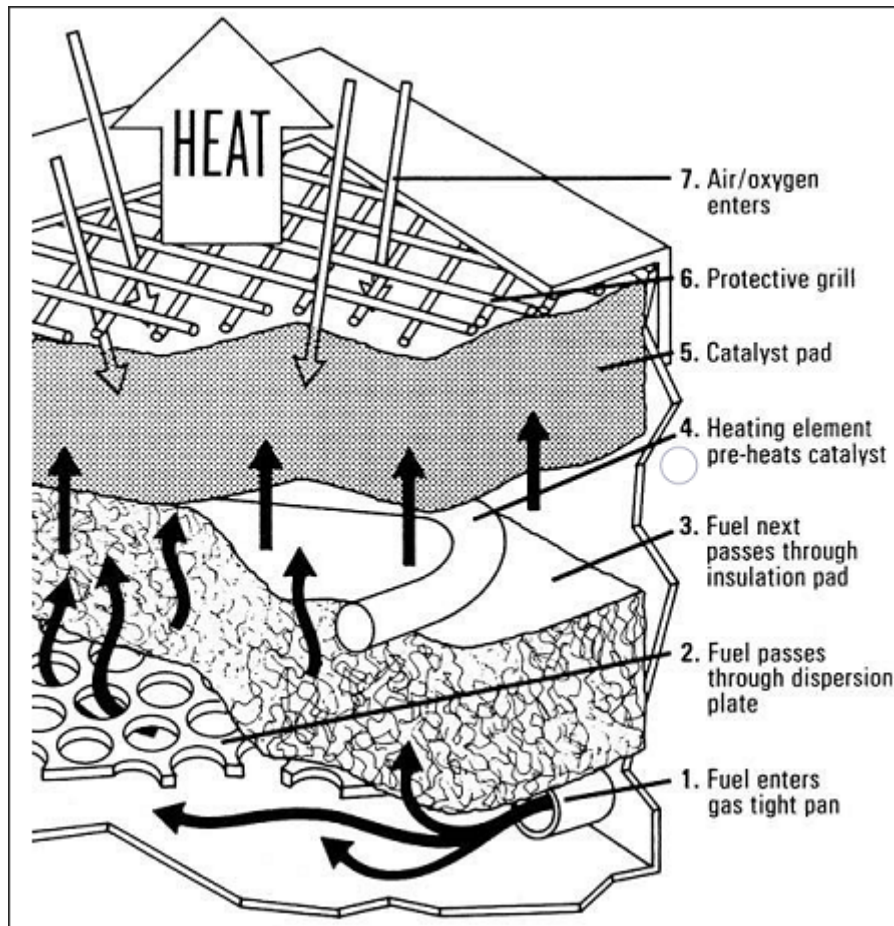

Figure 4: Catalytic Heater Diagram

7.2.2 The normal ignition temperature of natural gas in air at atmospheric pressure is 1202-1382 °F.

1. In the presence of the catalyst, the reacting takes place with sufficient velocity to start a chain reaction at a temperature of 225 °F.
2. If natural gas is brought into contact with the catalyst at 225 °F in the presence of oxygen, it is oxidized to carbon dioxide and water.
3. Sufficient heat is generated to raise the temperature of the bed, and oxidation continues if as gas and oxygen are supplied.

No flame is produced under these conditions since the gases are well below the ignition temperature.

7.3 Maintaining Temperature

7.3.1 The temperature attained in the catalyst bed is determined by the flow of gas to the bed, and the rate at which oxygen diffuses through the bed to replace that used up in the reaction.

1. If the rate of gas flow is **too high**, then there is not enough oxygen to completely burn the gas.
2. If the rate is **too low**, the gas is burned deeper in the bed and the surface becomes cooler.

3. Temperature is self-limiting. A properly designed unit will have a maximum and minimum gas flow with a maximum and minimum operating temperature, respectively, and can operate as long as there is sufficient gas flow to maintain the chain reaction
4. Overheating cannot occur, because gas flow is too high and will blanket the catalyst and exclude oxygen.

7.3.2 Since there is no flame, heater will not ignite even the most flammable material.

7.3.3 The heater will operate stably for long periods of time with no attention if gas and air are supplied.

7.4 Typical Installation/Mounting Position

7.4.1 Catalytic heaters take in combustion air from the atmosphere. For peak efficiency, it is recommended to install the heater so that its face (radiating surface) is in a near-vertical position.

7.4.2 When it is necessary to install a heater above the item to be heated, mount it at a minimum of 15° from the horizontal position.

7.4.3 If reflectors are used in a position other than vertical, drill holes along the side of the reflector attached to the heater, to allow proper circulation.

7.4.4 When used outdoors, mount heaters in an enclosure for protection from rain, wind, and snow.

7.5 Operation with Manual Control

7.5.1 Typical Start-Up

1. Turn gas valve off.
2. Energize electrical preheat supply connecting to heater terminals first, then to power supply.
3. Wait 20 minutes. In extremely cold weather, allow more time.
4. Turn on gas valve.
5. Wait 3 minutes.
6. Turn off electrical preheat supply.
7. Repeat if temperature does not rise sufficiently. In extremely cold weather, allow more time for step 3.

7.5.2 Typical Shut Down

1. Turn off gas supply valve.

7.6 Operation with Safety Shutoff Control

7.6.1 Typical Start-Up

1. Turn on gas valve.
2. Energize electrical preheat supply connecting to heater terminals first, then to power supply.
3. Wait 20 minutes.
4. Depress red button on control valve and release immediately. Button should return to original position.

5. If temperature does not rise, wait 5 additional minutes and repeat step 4.
6. When temperature rises (3-5 minutes) turn off electrical preheat supply.

7.6.2 Typical Shut-Down

1. Turn off gas supply valve.

7.7 Typical Use of Thermostats

7.7.1 Heater output temperatures can be controlled by installing a factory-preset thermostatic control valve between the final fuel-gas pressure regulator and the heater.

7.7.2 When the thermostat set point has been reached, the control valve closes and allows only a minimum of gas to flow through the bypass orifice inside the valve body.

1. Bypass must be factory-set for a specific flow.
2. This allows the heater to operate at a reduced temperature, eliminating the need to restart electrically.

Do not change the fuel-gas orifice, supplied with each heater, which has been properly sized to allow the correct amount of gas to each square foot of heater surface.

7.7.3 Fuel-gas pressure regulators are available, from the manufacturer, preset to provide natural gas at 3-1/2" w.c. (regulators for LP gas models are preset at 11" w.c.).

1. If regulators are obtained from any other source, it is extremely important that outlet pressure meet the above requirements.

7.7.4 Contact the factory before changing from one fuel to another (LP to natural gas, or natural gas to LP).

1. A proper replacement orifice can be substituted.
2. Replace or revise the name tag to indicate the change to a different fuel.

7.8 Typical Maintenance

7.8.1 Protect the face of the heater (the catalyst) when cleaning since high-pressure air or water can damage or destroy the catalyst.

7.8.2 When the heater is not in use, it should be protected so dirt and other materials do not collect on the catalyst surface.

7.9 Typical Troubleshooting Checklist

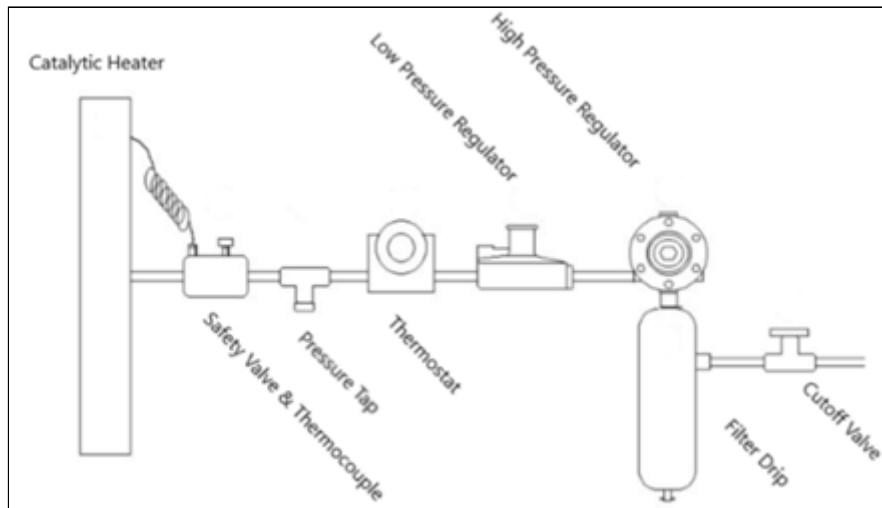

Figure 5: Catalytic Heater Control Schematic

7.9.1 If the heater will not start or fails to maintain temperature:

1. Check gas supply pressure between regulator and heater.
 - 1 a. It should be 3-1/2" - 4" w.c. for natural gas, 11" w.c. for LP gas.
2. Check orifice for obstructions.
3. Check mounting position of heater.
 - 3 a. *Face up* -- Condensation on heated surface may have saturated catalyst, or debris may have caked on face of heater.
 - 3 b. *Face down* -- Products of combustion may be starving heater from sufficient combustion air to support catalytic reaction.
4. Check for saturation of catalyst pad.
 - 4 a. If saturated with water, it will not function until the moisture is dried out.
 - (i) Drying can be accomplished by placing the heater face up in a conventional oven, at 250 °F for about 2 hours.
5. Oil or any hydrocarbon spilled on heater face normally will not damage the catalyst.
 - 5 a. Minor amounts, in most cases, will be absorbed in the combustion process.
 - 5 b. If oil saturation is heavy, return heater to the factory for cleaning or renovation.
6. Check safety shutoff control.
 - 6 a. Preheat electrically for 20 minutes, then depress red reset button and release.
 - 6 b. A pressure gauge or manometer located upstream of the safety valve will lower slightly if the valve is good.
 - 6 c. Downstream of the valve, pressure will rise from 0" - 3-1/2" w.c. when open.
7. Check millivolt output of the thermocouple by disconnecting from safety valve and attaching a millivolt meter.
8. Check electrical preheat elements for continuity as follows (see [Figure 6](#)):

UNCONTROLLED IF PRINTED

- 8 a. For 12V or 120V models, single element: Connect continuity meter to A and B.
- 8 b. For 12V or 120V models, two element:
 - (i) Remove external wiring and connect continuity meter to A and B.
 - (ii) Remove jumper bars from terminals A and C, then connect continuity meter to A and B.
 - (iii) Connect meter to terminals A and C.
 - (iv) Lack of continuity , in either check, indicates a defective element.
- 8 c. For 240V models: Remove external wiring and connect meter to A and C.
 - (i) Lack of resistance indicates a defective element.
9. If all the above checks indicate nothing is wrong with the heater, contact factory for further information.

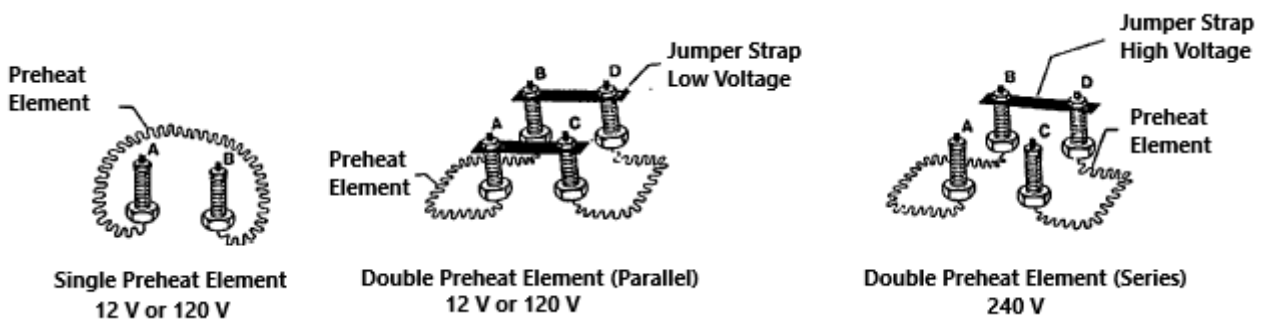

Figure 6: Catalytic Heater Preheat Terminals

10. Do not disassemble heaters in the field.
 - 10 a. Special tools, equipment, and expertise are required to repair and test catalytic heaters.
 - 10 b. Repairs can only be accomplished at the factory.

End of Instructions.

Operator Qualification (OQ) Required?

YES

0301: Manually Opening and Closing Valves

Appendices

[Appendix A - Antifreeze Requirements](#)

Attachments

NONE.

Compliance Requirements

ICC 530.10 Standards

Reference Documents

UNCONTROLLED IF PRINTED

[Bruest Catalytic Heater](#) (online reference)

Document Rescission

REGS 2.06 Regulator Stations: Gas Heaters, April 1, 2020.

Revision Notes

Location of Changes	Summary of Changes
Not applicable.	This is a new document.

Appendix A - Antifreeze Requirements

Shell Size	U.S. Gallons Capacity	Gallons Ethylene Glycol for 0°F Protection	Gallons Ethylene Glycol for -25°F Protection	Gallons Ethylene Glycol for -50°F Protection
18" x 5'	45	15	21	25
24" x 5'	112	37	53	63
24" x 7.5'	140	46	66	78
24" x 10'	185	61	87	104
30" x 10'	275	91	129	154
36" x 10'	365	120	172	204
36" x 12'	435	144	204	244
42" x 15'	750	248	353	420
48" x 12'	875	289	411	490
48" x 15'	1,050	347	494	588
48" x 17.5'	1,250	413	588	700
60" x 12'	1,400	462	658	784
60" x 15'	1,750	578	823	980
60" x 18'	2,100	693	987	1,176
60" x 22.5'	2,640	871	1,241	1,478
72" x 18'	3,030	1,000	1,424	1,697
72" x 22.5'	3,800	1,254	1,786	2,128
72" x 25'	4,230	1,396	1,988	2,369
72" x 30'	5,070	1,673	2,383	2,839
84" x 22.5'	5,180	1,709	2,435	2,901
84" x 25'	5,760	1,901	2,707	3,226
84" x 30'	6,900	2,277	3,243	3,864
96" x 22.5'	6,760	2,231	3,177	3,786
96" x 30'	9,010	2,973	4,235	5,046

1.0 Purpose

This document provides the minimum requirements for regulators station design in accordance with 49 CFR Part 192, Subpart D.

2.0 Scope

This document addresses the following:

[3.0 Target Audience](#)

[4.0 General](#)

[5.0 General Guidelines and Requirements](#)

[6.0 Standardized Design Features](#)

[7.0 Standardized Regulator Station Drawings](#)

Appendices

[Appendix A - Regulator Station Specifications](#)

3.0 Target Audience

- Gas Engineer
- Gas Tech Engineering (GTE)
- Corrosion Control
- Gas Tech Services (GTS)

4.0 General

- 4.1 This document has been prepared to provide designs for gas distribution regulator stations.
- 4.2 Standardized design stations were developed for commonly used design conditions.
- 4.2.1 Regulator stations should be designed by Gas Tech Engineering (GTE).

5.0 General Guidelines and Requirements

- 5.1 Standardized regulator stations include all material from inlet riser to outlet riser.
- 5.1.1 Designer is responsible for specifying and ordering inlet and outlet piping and emergency valves.
- 5.2 Inlet and outlet emergency valves, where required, shall be provided as recommended in [VALV 2.1](#).
- 5.3 Standardized distribution regulator stations are designed to supply an outlet system MAOP of 60 psig or lower. Contact GTE for an outlet system MAOP over 60 psig.
- 5.4 Operating pressure limits shall be determined by ANSI design class (piping) or equipment ratings (regulator/relief valve), whichever is lowest.
- 5.5 Cathodic protection isolation insulator is normally installed on the outlet side of the station before a block valve.
- 5.5.1 Above the ground insulation is normally provided by using flanges and an insulating flange kit.

- 5.5.2 Install welded bolts and jumper wire/flange fink on one run. See [CORR 2.8](#) Flange Fink Test Station for installation details.
- 5.5.3 When required, below the ground insulation should be provided by a weld-end insulator.
- 5.5.4 Ensure that insulation fittings are properly rated for the system MAOP.
- 5.5.5 For outlet systems that use PE pipe, insulation normally shall not be installed.
 - 1. Tracer wire shall not be bonded to the station.
 - 2. Terminate tracer wire in a cathodic protection test station.
- 5.5.6 Cathodic protection design for station should be reviewed by Corrosion Control, GTE, or Region Engineering personnel. Refer to [CORR 2.1](#) for additional cathodic protection details.
- 5.6 Strength and leak tests shall be performed in accordance with [PTST 1 Section 10.0](#) - Testing. Do not test through regulators or relief valves.
- 5.7 GTE shall be responsible for providing all sizing, set points, and capacities for standardized gas regulator stations.
- 5.8 GTE and GTS are responsible to determine the need for an indirect pipeline heater and/or for adding provisions for adding a heater in the future.
- 5.9 GTE and GTS should determine if a catalytic heater should be considered to heat the pilot gas. Refer to [REGS 2.4](#).
 - 5.9.1 If catalytic heat is required, it is recommended that single coil catalytic heaters be used. See [Figure 1](#).

Use of a catalytic heater is most important on pilot operated monitor regulator stations.

- 5.9.2 A pilot gas supply filter is recommended upstream of the supply regulator for the heater. See [Figure 2](#).



Figure 1: Single Coil Catalytic Heater



Figure 2: Pilot Supply Filter

6.0 Standardized Design Features

Internal relief or internal monitor regulators shall not be used in the standard regulator piping design.

- 6.1 To reduce noise, pipe shall be sized so the velocity of the gas does not exceed 200 fps above ground and 400 fps below ground.
- 6.2 Where total pressure drop across the station is 300 psig or greater, consider installing heaters (catalytic or indirect) to prevent equipment freeze-up. Refer to [REGS 2.4](#).

UNCONTROLLED IF PRINTED

For every 100 psig pressure differential across a regulator station, there is approximately 7 °F drop in gas temperature.

- 6.3 Every system supplied by more than one regulator station shall be equipped with telemetering or recording pressure gauges to indicate the system gas pressure. Refer to [PRES 1 Subsection 5.1](#) Pressure Monitoring Locations.
- 6.4 Control lines must be of sufficient size to allow for proper operation of the equipment.
- 6.4.1 Installation of control lines above the ground is recommended.
1. Short runs, above ground, of 10 feet or less should be 3/8" stainless steel tubing.
 2. Longer runs, above ground, 3/4" black steel piping or 1/2" stainless steel tubing should be used.
- 6.4.2 Minimize installation of below grade control lines whenever possible.
1. New below grade control lines shall be 3/4 inch cathodically protected coated steel pipe separated to avoid damage from a single excavation and back-filled with sand padding.
 2. Install "Caution Gas Pipeline Buried Below" warning tape (16 06 958) over the control line approximately 12 inches below the surface.
 3. Clearly documented new below grade control lines on the as-built construction prints.
- 6.5 When using pilot operated equipment, a filter shall be provided in the pilot supply line. In some cases, the required filter is part of the pressure regulating equipment. See [Figure 2](#).
- 6.6 Control line connections shall be made in a straight run of pipe, if possible, 8-10 pipe diameters downstream of areas of turbulence such as:
- 6.6.1 Elbows.
- 6.6.2 Valves.
- 6.6.3 Tees.
- 6.7 Control lines may require the addition of insulating fittings to provide electrical insulation for cathodic protection.
- 6.8 Each control line shall have a shutoff valve installed as near as practical to the point of connection to the regulator station piping.
- 6.9 Common control line taps are not allowed. Each individual regulator supply and sensing line shall have a unique tap location that is drilled with the largest tap allowed by the fitting.
- 6.10 Inlet and outlet steel risers shall be coated in accordance with [CORR 2.3 Subsection 4.6](#) - Soil to Air Interface Zone.
- 6.11 Support inlet and outlet risers as necessary on compacted or undisturbed earth.
- 6.12 Provide additional layer of protection (wrapping, FRP, rock shield, etc.) on all pipe in contact with below grade pipe supports. For above grade pipe supports, see [CORR 2.7 Subsection 12.3](#) Preformed FRP Spacers - Type 120.

6.13 For above grade pipe supports, I-Rod spacers or Nu-Bolts are the preferred method for providing protection against atmospheric corrosion and electrical short. Refer to [CORR 2.7 Subsection 12.2](#).

6.14 Evaluate, new or replaced above the ground, regulator stations for the need of protection from accidental damage by vehicular traffic or other similar causes.

6.14.1 If protection is needed place the facility at a safe distance from traffic.

OR

6.14.2 Install protective barricades.

6.15 When determining a safe distance between the above ground regulator station and vehicular traffic consideration shall be given to the following relevant factors:

6.14.1 Type of roadway.

6.14.2 Type of driveway.

6.14.3 Distance from highway/street.

6.14.4 Off Road activity.

6.14.5 Speed Limit.

6.14.6 Direction of traffic.

6.14.7 Natural or other barriers.

6.14.8 Weather and Environmental hazards.

6.16 Security fencing to prevent unauthorized entry shall be considered for new or replaced above the ground regulator stations with:

6.15.1 Exposed regulator control lines.

6.15.2 High pedestrian traffic area.

6.15.3 High crime area.

6.15.4 Near school grounds.

6.17 Relief stacks should be supported, as necessary. The top of any relief stack should be a minimum of 6 feet above ground level.

6.18 All regulator station valves and control line valves shall be protected from unauthorized use. See Figure 3.



Figure 3: Regulator Station Locking Devices

- 6.19 Consideration should be given to installing multiple regulator cuts per run at differential pressures greater than 300 PSIG.
- 6.20 For additional protection on a boot style monitor regulator station, the outlet token relief valve should be a Fisher 1" 289P or 1" 289H (or equivalent) to provide additional failure protection in the event of liquid build up on the flexible boot element. (See Figures 4 and 5).



Figure 4 Relief Valve - 289P



Figure 5 Relief Valve - 289H

7.0 Standardized Regulator Station Drawings

- 7.1 The tables in [Appendix A](#) lists the standardized regulator station designs included in this section of the O&M Plan.
- 7.2 Standard construction drawings of the regulator stations listed in Appendix A are available in [REGS 4](#).

End of Instructions.

Operator Qualification (OQ) Required?

NO.

Appendices

[Appendix A - Regulator Station Specifications](#)

Attachments

NONE.

Compliance Requirements

49 CFR Part 192, Subpart D

UNCONTROLLED IF PRINTED

Reference Documents

[CORR 2.1 Corrosion Control: Cathodic Protection Design](#)

[CORR 2.3 Corrosion Control: Coatings](#)

[CORR 2.7 Corrosion Control: Short Investigation and Clearing Shorted Pipelines](#)

[CORR 2.8 Corrosion Control: Cathodic Protection Testing](#)

[PTST 1 Pressure Testing: Requirements](#)

[VALV 2.1 Valves: Valve Installation](#)

Document Rescission

REGS 3 Regulator Stations: Regulator Station Design, October 1, 2020.

Revision Notes

Location of Changes	Summary of Changes
Subsection 6.3	Added reference to PRES 1 Subsection 5.1 for pressure monitoring locations
Subsection 6.13	Introduced the I-Rod spacers and Nu-Bolts as the preferred method for protecting the pipe from atmospheric corrosion and electrical shorts on above grade pipe supports. Changed the referenced to CORR 2.7 Subsection 12.2.

Appendix A - Regulator Station Specifications

A-1. Series RS100 Compact Stations (3/4" Farm Tap Style Regulator)

Station Number & Type	Risers (Inlet x Outlet)	ANSI Class	Inlet MAOP PSIG	Outlet MAOP PSIG
RS110 - Single Cut Horizontal	3/4" x 2"	300	740	60
RS120 - Double Cut Horizontal	3/4" x 2"	300 - 600	740 - 1480	60
RS130 - Single Cut Vertical	2" x 2"	300	740	60
RS140 - Double Cut Vertical	2" x 2"	300 - 600	740 - 1480	60

1. Inlet and outlet pressure ratings listed are for station piping only.
2. Regulators, relief valves, and inlet/outlet systems may further limit station operating pressure ratings.
3. Maximum outlet flow ratings are determined at 60 psig and 200 feet per second gas velocity in outlet piping.
4. Outlet pressures below 60 psig will reduce station capacity below listed flow rate.

A-2. Series RS200 Convertible Stations (3/4" Farm Tap Style - Future Conversion to RS300/RS400)

Station Number & Type	Risers (Inlet x Outlet)	ANSI Class	Inlet MAOP PSIG	Outlet MAOP PSIG
RS210A - Convertible Single Cut (Compact)	2" x 2"	150 FF	285	60
RS210B - Convertible Single Cut (Extended)	2" x 2"	150 FF	285	60

UNCONTROLLED IF PRINTED

RS220A - Convertible Single Cut (Compact)	2" x 2"	300	740	60
RS220B - Convertible Single Cut (Extended)	2" x 2"	300	740	60
RS230A - Convertible Double Cut (Compact)	2" x 2"	300	740	60
RS230B - Convertible Double Cut (Extended)	2" x 2"	300	740	60
RS240A - Convertible Double Cut (Compact)	2" x 2"	600	1,480	60
RS240B - Convertible Double Cut (Extended)	2" x 2"	600	1,480	60

1. Inlet and outlet pressure ratings listed are for station piping only.
2. Regulators, relief valves, and inlet/outlet systems may further limit station operating pressure ratings.
3. Maximum outlet flow ratings are determined at 60 psig and 200 feet per second gas velocity in outlet piping.
4. Outlet pressures below 60 psig will reduce station capacity below listed flow rate.

A-3. Series RS300 Wide-Open (Passive) Monitor

Station Number & Type	Risers (Inlet x Outlet)	ANSI Class	Inlet MAOP PSIG	Outlet MAOP PSIG
RS310A - Wide-Open Monitor (Compact)	2" x 2"	150 FF	285	60
RS310B - Wide-Open Monitor (Extended)	2" x 2"	150 FF	285	60
RS320A - Wide-Open Monitor (Compact)	2" x 2"	300	740	60
RS320B - Wide-Open Monitor (Extended)	2" x 2"	300	740	60
RS330A - Wide-Open Monitor (Compact)	2" x 4"	150 FF	285	60
RS330B - Wide-Open Monitor (Extended)	2" x 4"	150 FF	285	60
RS340A - Wide-Open Monitor (Compact)	2" x 4"	300	740	60
RS340B - Wide-Open Monitor (Extended)	2" x 4"	300	740	60

1. Inlet and outlet pressure ratings listed are for station piping only.
2. Regulators, relief valves, and inlet/outlet systems may further limit station operating pressure ratings.
3. Maximum outlet flow ratings are determined at 60 psig and 200 feet per second gas velocity in outlet piping.
4. Outlet pressures below 60 psig will reduce station capacity below listed flow rate.

A-4. Series RS400 Working Monitor Stations

Station Number & Type	Risers (Inlet x Outlet)	ANSI Class	Inlet MAOP PSIG	Outlet MAOP PSIG
-----------------------	-------------------------	------------	-----------------	------------------

UNCONTROLLED IF PRINTED

RS410A - Working Monitor (Compact)	2" x 2"	300	740	60
RS410B - Working Monitor (Extended)	2" x 2"	300	740	60
RS420A - Working Monitor (Compact)	2" x 2"	600	1,480	60
RS420B - Working Monitor (Extended)	2" x 2"	600	1,480	60
RS430A - Working Monitor (Compact)	2" x 4"	300	740	60
RS430B - Working Monitor (Extended)	2" x 4"	300	740	60
RS440A - Working Monitor (Compact)	2" x 4"	600	1,480	60
RS440B - Working Monitor (Extended)	2" x 4"	600	1,480	60

1. Inlet and outlet pressure ratings listed are for station piping only.
2. Regulators, relief valves, and inlet/outlet systems may further limit station operating pressure ratings.
3. Maximum outlet flow ratings are determined at 60 psig and 200 feet per second gas velocity in outlet piping.
4. Outlet pressures below 60 psig will reduce station capacity below listed flow rate.

REGULATOR STATIONS

December 1, 2020

REGS 4 Forms and Reference Materials

Click on the links below to open the documents.

References

1. [RS000 Title Block](#)
2. [RS110 Single Cut Horizontal](#)
3. [RS120 Double Cut Horizontal](#)
4. [RS130 Single Cut Vertical](#)
5. [RS140 Double Cut Vertical](#)
6. [RS210-A Convertible Single Cut Compact 285 Inlet MAOP](#)
7. [RS210-B Convertible Single Cut Extended 285 Inlet MAOP](#)
8. [RS220-A Convertible Single Cut Compact 740 Inlet MAOP](#)
9. [RS220-B Convertible Single Cut Extended 740 Inlet MAOP](#)
10. [RS230-A Convertible Double Cut Compact 740 Inlet MAOP](#)
11. [RS230-B Convertible Double Cut Extended 740 Inlet MAOP](#)
12. [RS240-A Convertible Double Cut Compact 1480 Inlet MAOP](#)
13. [RS240-B Convertible Double Cut Extended 1480 Inlet MAOP](#)
14. [RS310-A Wide Open Monitor Compact 285 Inlet MAOP](#)
15. [RS310-B Wide Open Monitor Extended 285 Inlet MAOP](#)
16. [RS320-A Wide Open Monitor Compact 740 Inlet MAOP](#)
17. [RS320-B Wide Open Monitor Extended 740 Inlet MAOP](#)
18. [RS330-A Wide Open Monitor Compact 285 Inlet MAOP](#)
19. [RS330-B Wide Open Monitor Extended 285 Inlet MAOP](#)
20. [RS340-A Wide Open Monitor Compact 740 Inlet MAOP](#)
21. [RS340-B Wide Open Monitor Extended 740 Inlet MAOP](#)
22. [RS410-A Working Monitor Compact 740 Inlet MAOP](#)
23. [RS410-B Working Monitor Extended 740 Inlet MAOP](#)
24. [RS420-A Working Monitor Compact 1480 Inlet MAOP](#)
25. [RS420-B Working Monitor Extended 1480 Inlet MAOP](#)
26. [RS430-A Working Monitor Compact 740 Inlet MAOP](#)
27. [RS430-B Working Monitor Extended 740 Inlet MAOP](#)
28. [RS440-A Working Monitor Compact 1480 Inlet MAOP](#)
29. [RS440-B Working Monitor Extended 1480 Inlet MAOP](#)

End of Section.

UNCONTROLLED IF PRINTED

Document Rescission

REGS 4 Regulator Stations: Forms and Reference Materials, January 1, 2018.

Revision Notes

Location of Changes	Summary of Changes
Not applicable.	This is a new document.

RNST-Reinstating of Facilities

REINSTATING OF FACILITIES

October 1, 2020

RNST 0 Table of Contents

[RNST 1 Reinstating of Facilities: Requirements and Reinstating Mains and Service](#)

Section 1.0 Purpose

Section 2.0 Scope

Section 3.0 Target Audience

Section 4.0 General

Section 5.0 Reconnection of Temporarily Disconnect Services

Section 6.0 Reconnection of Temporarily Disconnected Farm Taps

Section 7.0 Reconnection of Temporarily Disconnected Mains

Section 8.0 Reinstating Service in Abandoned Mains

Section 9.0 Records

Operator Qualification (OQ)

Compliance Requirements

Reference Documents

Document Rescission

End Table of Contents.

Document Rescission

RNST 0 Reinstating of Facilities: Table of Contents, January 1, 2018.

Revision Notes

Location of Changes	Summary of Changes
Not applicable.	This is a new document.

REINSTATING OF FACILITIES

October 1, 2021

RNST 1 Requirements and Reinstating Mains and Service

1.0 Purpose

This document specifies requirements for re-testing temporarily deactivated mains and services prior to reinstatement, in accordance with 49 CFR §§ 192.517 and .§192.725.

2.0 Scope

This document addresses the following:

[3.0 Target Audience](#)[4.0 General](#)[5.0 Reconnection of Temporarily Disconnected Services](#)[6.0 Reconnection of Temporarily Disconnected Farm Tap Services](#)[7.0 Reconnection of Temporarily Disconnected Mains](#)[8.0 Reinstating Service in Abandoned Mains](#)[9.0 Records](#)**3.0 Target Audience**

- Corrosion Control
- Region Engineering
- Gas Engineering
- Gas Tech Engineering (GTE)
- Gas Distribution Design Specialist
- Gas Field Personnel
- Gas Supervisors
- Gas Construction Services Supervisors
- Gas Tech Services (GTS) Supervisors
- Gas Tech Services (GTS) Technicians

4.0 General

4.1 In general, previously abandoned gas facilities that have been physically disconnected from the source of gas, purged, sealed and are no longer maintained should not be considered for reinstatement without a thorough engineering evaluation to verify the facilities' integrity and serviceability. Gas engineering shall approve reinstatement plans for previously abandoned facilities. Refer to [Section 8.0](#) Reinstating Service in Abandoned Mains as a guide for an engineering evaluation.

4.2 Service lines

- 4.2.1 Previously abandoned service lines shall not be placed back in service without gas engineering approval
- 4.2.2 If a gas service line has been physically disconnected from the main supplying it, then the service line shall be tested as a new service line at that location before reinstatement

4.3 Mains

- 4.3.1 *Reinstalling a temporarily deactivated main:* Only new pipe installed within the segment of main requires testing in accordance with [PTST 1](#), before main can be put back in service. See [Section 7.1](#) for details.

UNCONTROLLED IF PRINTED

4.3.2 *Repairing a damaged section of main:* If a new section of pipe is installed to repair a damaged section of main, the new section shall be tested in same manner as a new main.

1. The new section of pipe can be pretested prior to installation. See [REPR 1 Section 10.0](#).

4.3.3 Reinstating previously abandoned mains: Refer to [Section 8.0](#) Reinstating Service in Abandoned Mains.

5.0 Reconnection of Temporarily Disconnected Services

- 5.1 Any service line physically disconnected from main must be tested in the same manner as a new service line before reconnecting. See [PTST 1.1](#), to select appropriate test pressure and test duration table. Refer to 49 CFR §192.725.
- 5.2 If the gas service line is damaged such that it has to be temporarily disconnected from its supply, the service line shall be tested from the point of disconnection to the meter valve. See [REPR 1 Subsection 10.1.5](#) Service line test requirements.
 - 5.2.1 Perform flame ionization (FI) or gas detection instrument survey or sufficient bar testing from main to the damaged section, using a combustible gas indicator to check for leakage.
- 5.3 If there is any indication of physical movement caused by damage, the entire service shall be re-tested.
- 5.4 If provisions are made to maintain continuous service (e.g. installation of a by-pass), then it is not necessary to test the part of the original service line that is used to maintain continuous service.
- 5.5 If a service line has been taken out of service by closing a valve on the service line, then the line is still considered connected and does not need to be retested.

6.0 Reconnection of Temporarily Disconnected Farm Tap Services

- 6.1 When possible, it is recommended that only the regulator head be removed, leaving the regulator body connected to the farm tap piping.
 - 6.1.1 Using this method will not require testing the service line before reinstalling the regulator head, since service line is still connected to the gas source.
- 6.2 If the regulator is completely removed from the farm tap piping, then the service line is considered disconnected from the gas source and must be retested before reinstating the service.
 - 6.2.1 *Farm taps with one regulator:* Outlet piping from regulator to meter valve shall be pressure tested as specified in [PTST 1.1 Appendix F](#).
 - 6.2.2 *Downstream (second cut) regulators removed from farm tap with two-stage regulation:* Outlet piping from second cut regulator to meter valve shall be pressure tested as specified in [PTST 1.1 Appendix G](#).
 - 6.2.3 *Upstream (first cut) regulators removed from farm tap with two-stage regulation:* Piping between first cut regulator and inlet to second cut regulator shall be pressure tested as specified in [PTST 1.1 Appendix G](#).
- 6.3 Regulators and relief valves shall be removed during testing.
- 6.4 After reinstating service, regulator and relief valve connections shall be leak tested using leak detection fluid or instrument at current operating pressure.

7.0 Reconnection of Temporarily Disconnected Mains

- 7.1 Mains temporarily disconnected from their supply source shall be tested in accordance with the following requirements before they can be reconnected:
- 7.1.1 *Facilities Not Disturbed*: Temporarily-disconnected mains do not need not be re-tested if they have not been disturbed.
 - 7.1.2 *Facilities Moved within a Trench*: Mains which are moved within a trench, but not lifted out of the trench, shall be visually inspected to ensure that all joints are sound and that no damage has been done to the pipe. Pressure testing is not required.
 - 7.1.3 *Facilities Lifted from a Trench*:
 - 1. *Mains which are lifted out of a trench and returned to the same trench*: Pipe shall be visually inspected to ensure that all joints are sound and that no damage has been done to the pipe. Pressure testing is not required.
 - 2. *Mains which are lifted out of a trench and placed in a different location*: Pressure test in the same manner as new lines in their final location.
 - 2 a. See [PTST 1.1](#) to select the appropriate test pressure and test duration table.
 - 2 b. The pipe shall be visually inspected to ensure that all joints are sound and that no damage has been done to the pipe.
 - 7.1.4 *Facilities Cut into Sections*: New main segments installed between undisturbed main sections shall be tested in the same manner as new main in that location.
 - 1. All new welds shall be inspected as required for new facilities. See [WELD 1](#) and [WELD 2.3](#).
 - 2. See [PTST 1.1](#) to select the appropriate test pressure and test duration table.
- 7.2 When reconnected to the undisturbed section, tie-in joints shall be leak tested with leak detection fluid or leak detection instrument with the main under current operating pressure.

8.0 Reinstating Service in Abandoned Mains

- 8.1 A previously abandoned main/facility may be returned to service in accordance with the following requirements:
- 8.1.1 An in-depth evaluation must be performed to determine if integrity of main/facility is or can be made suitable for reinstatement.
 - 1. Evaluation should be performed by personnel from various groups such as:
 - 1 a. Gas Tech Engineering (GTE)
 - 1 b. Region Engineering
 - 1 c. Gas Tech Services (GTS)
 - 1 d. Corrosion Control
 - 1 e. Other applicable groups
 - 8.1.2 The abandoned main/facility shall meet all requirements of a new facility installed at that location. The main/facility shall be tested in the same manner as a new line being installed in same location. See [PTST 1.1](#).

8.1.3 Perform cathodic protection survey of steel lines. See [CORR 1](#).

8.1.4 Check the previously abandoned main for internal obstruction (i.e. debris or liquids) by either pigging or purging.

9.0 Records (49 CFR §192.517)

9.1 All pressure test information will be maintained in Maximo or in the As Built Construction File.

9.2 All pressure test information shall be retained for the life of the facility.

End of Instructions.

Operator Qualification (OQ) Required?

YES

0151: Visual Inspection of Buried Pipe and Components when Exposed

0201: Visual Inspection of Installed Pipe and Components for Mechanical Damage

0561: Pressure Test - Nonliquid Medium - MAOP Less than 100 PSI

0571: Pressure Test - Nonliquid Medium - MAOP Greater than or Equal to 100 PSI

0581: Pressure Test - Liquid Medium

0591: Leak Test - Operating Pressure

0641: Visually Inspect Pipe and Components Prior to Installation

0811: Visual Inspection of Welding and Welds

1201: Temporary Isolation of Service Lines and Service Discontinuance

1651: Purge - Flammable or Inert Gas

A001: Service Reconnect

Appendices

NONE.

Attachments

NONE.

Compliance Requirements

49 CFR §192.517 Records.

49 CFR §192.725 Test requirements for reinstating service lines.

Reference Documents

[CORR 1 Corrosion Control: Requirements](#)

[PTST 1 Pressure Testing: Requirements](#)

[PTST 1.1 Pressure Testing: Test Pressure and Duration Requirement Tables](#)

[REPR 1 Repairs: Requirements](#)

UNCONTROLLED IF PRINTED

[WELD 1 Welding: Requirements](#)

[WELD 2.3 Welding: Construction of Pipelines](#)

Document Rescission

RNST 1 Reinstating of Facilities: Requirements, April 1, 2021.

Revision Notes

Location of Changes	Summary of Changes
Section 4.1	Revised to require an engineering evaluation to verify the facilities' integrity and serviceability. Gas engineering shall approve reinstatement plans for previously abandoned facilities.
Paragraph 4.2.1 – Service Lines	New – Previously abandoned service lines shall not be placed back in service without gas engineering approval.
Paragraph 4.3.3 – Mains	New – Reinstating previously abandoned mains: Refer to Section 8.0 Reinstating Service in Abandoned Mains.

SAFT-Safety-Related Conditions

SAFETY-RELATED CONDITIONS

October 1, 2022

SAFT 0 Table of Contents

[SAFT 1 Safety-Related Conditions: Requirements](#)

Section 1.0 - Purpose

Section 2.0 - Scope

Section 3.0 - Target Audience

Section 4.0 - Regulatory Requirements

Section 5.0 - Handling Responsibilities

Section 6.0 - Reporting SRCs

Section 7.0 - Transmission MAOP Exceedance Report

Operator Qualification (OQ)

Appendices

Appendix A - Preamble Statement to Amdt. 191-7

Attachments

[Attachment 1 - Determination of Reporting Requirements for Safety-Related Conditions for Pipeline Facilities Other Than Underground Natural Gas Storage Facilities.](#)

[Attachment 2 – Determination of Reporting Requirements for Safety-Related Conditions for Underground Natural Gas Storage Facilities.](#)

Compliance Requirements

Reference Documents

Document Rescission

Revision Notes

[SAFT 1.1 Reporting Requirements](#)

Section 1.0 - Purpose

Section 2.0 - Scope

Section 3.0 - Target Audience

Section 4.0 - Reporting Requirements Related to Gas Storage and Company Changes

Operator Qualification (OQ)

UNCONTROLLED IF PRINTED

Appendices

Attachments

Compliance Requirements

Reference Documents

Document Rescission

Revision Notes

Document Rescission

SAFT 0 Safety-Related Conditions: Table of Contents, July 1, 2010.

Revision Notes

Location of Changes	Summary of Changes
SAFT 1.1	New section added effective May 10, 2021

SAFETY-RELATED CONDITIONS

October 1, 2022

SAFT 1 Requirements**1.0 Purpose**

This document is to ensure that any "safety-related condition" is recognized and that proper determination is made by Ameren Illinois (AIC) to report such conditions in accordance with the requirements of 49 CFR Part 191, specifically §191.23 Reporting safety-related conditions.

2.0 Scope

This document addresses the following:

[3.0 Target Audience](#)**[4.0 Regulatory Requirements](#)****[5.0 Handling Responsibilities](#)****[6.0 Reporting SRCs](#)****[7.0 Transmission MAOP Exceedance Report](#)**

Appendices

[Appendix A - Preamble Statement \(Amendment 191-7 to 49 CFR §191.25\)](#)

Attachments

[Attachment 1 - Determination of Reporting Requirements for Safety-Related Conditions for Pipeline Facilities Other Than Underground Natural Gas Storage Facilities.](#)**[Attachment 2 – Determination of Reporting Requirements for Safety-Related Conditions for Underground Natural Gas Storage Facilities.](#)**

(Attachments copied from GTPC's Guide for Gas Transmission, Distribution, and Gathering Piping Systems by Gas Piping Technology Committee (© American Gas Association, reprinted with permission.)

3.0 Target Audience

- Gas Compliance Personnel
- Gas Superintendents
- Gas Supervisors
- Gas Field Personnel
- Gas Tech Engineering (GTE)
- Gas Technical Services (GTS) Superintendents
- Gas Technical Services (GTS) Supervisors
- Gas Tech Service(GTS) Technicians
- Gas Storage Engineering (GSE)
- Gas Storage Field Superintendents
- Gas Storage Field Supervisors
- Gas Storage Field Operators
- Gas Control Personnel

4.0 Regulatory Requirements (49 CFR §191.23)**4.1 Definition:**

UNCONTROLLED IF PRINTED

- 4.1.1 A safety-related condition (SRC) is a situation that affects the operation of a pipeline and is required to be repaired or reported within 5 working days after determination or 10 working days after discovery, whichever comes first.
- 4.1.2 If a transmission pipeline's maximum emergency pressure (MEP) is exceeded, a report is required to be filed within 5 days of the occurrence. See [Section 7.0](#) Transmission MAOP Exceedance Report.
- 4.1.3 Refer to [Attachment 1](#) Determination of Reporting Requirements for Safety-Related Conditions for Pipeline Facilities Other Than Underground Natural Gas Storage Facilities for determining the requirements to report SRCs to PHMSA and the ICC.

4.2 **Pipeline facilities:** Situations that may result in an SRC are as follows:

- 4.2.1 Refer to [Attachment 2](#) Determination of Reporting Requirements for Safety-Related Conditions for Underground Natural Gas Storage Facilities for determining the requirements to report SRCs to PHMSA, and IDNR
- 4.2.2 General corrosion on a pipeline that operates at 20% SMYS or greater and has reduced pipe wall thickness to less than that required for the maximum allowable operating pressure (MAOP), or localized corrosion pitting to degree where leakage might result.
- 4.2.3 Unintended movement or abnormal loading by environmental causes, such as earthquake, landslide, or flood that impairs the pipeline serviceability.
- 4.2.4 Any material defect or physical damage that impairs serviceability of a pipeline that operates at 20% SMYS or greater.
- 4.2.5 Equipment malfunction or operating error that causes pressure of a distribution line to rise above its MAOP plus allowable buildup (MEP) for pressure limiting or control devices.
- 4.2.6 For equipment malfunction or operating error that causes pressure of a transmission pipeline to rise above its MAOP plus allowable buildup (MEP) for pressure limiting or control devices; see [Section 7.0](#) that addresses "Transmission MAOP Exceedance Report".
- 4.2.7 A pipeline leak that constitutes an emergency.
- 4.2.8 Any condition that could lead to an imminent hazard and causes a 20% or more reduction in operating pressure or pipeline shutdown.

4.3 **Underground storage facilities:** Situations that may result in an SRC are as follows:

Underground natural gas storage facilities include injection, withdrawal, monitoring, or observation wells under Illinois Department of Natural Resources' jurisdiction.

- 4.3.1. General corrosion that has reduced the wall thickness to less than that required for the maximum well operating pressure, or localized corrosion pitting to degree where leakage might result.
- 4.3.2. Unintended movement or abnormal loading by environmental causes, such as earthquake, landslide, or flood that impairs structural integrity or reliability.
- 4.3.3. Any crack or other material defect that impairs structural integrity or reliability.

- 4.3.4. Any material defect or physical damage that impairs the serviceability.
- 4.3.5. Any malfunction or operating error that causes pressure to rise above its maximum well-allowable operating pressure plus allowable buildup for pressure limiting or control devices.
- 4.3.6. A leak that constitutes an emergency.
- 4.3.7. Any condition that could lead to an imminent hazard and:
 - 1. Causes a 20% or more reduction in operating pressure, or
 - 2. Results in a facility shutdown.

5.0 Handling Responsibilities

- 5.1 Gas field personnel or Gas Storage Field Operators will report to the Gas Supervisor or Supervisor Gas Storage all SRCs that might affect the operation of AIC pipeline facilities.
- 5.2 Gas Supervisor or Supervisor Gas Storage shall notify Gas Compliance of all SRCs and any corrective actions taken.
- 5.3 Gas Control remotely monitors many of the AIC gas systems/facilities and inter-connections with interstate pipelines. Various duties include the following:
 - 5.3.1. Gas Control shall respond to the associated alarm if safety-related parameters are violated regarding:
 - 1. Pressure,
 - 2. Flow, or
 - 3. Odorization.
 - 5.3.2. If Gas Control cannot remedy situation by using the SCADA system, responsibility will be turned over to the appropriate:
 - 1. Gas Supervisor, or
 - 2. Gas Technical Services (GTS) Supervisor.AND
 - 3. Gas Control will remain in a supportive role.
 - 5.3.3. The Gas Supervisor or GTS Supervisors do one of the following:
 - 1. Provide Gas Control with additional instructions,
 - 2. Call-out gas field personnel or GTS Technician to investigate, or
 - 3. Assume responsibility for addressing the situation.
 - 5.3.4. Communications shall be maintained with Gas Control through-out the event and gas field personnel or GTS Technician shall report their findings and how the situation was resolved.
 - 5.3.5. Gas Control shall maintain a record of how the alarm was handled and how SRC was returned to normal.
- 5.4 All applicable actions to correct SRCs shall be scheduled immediately.

6.0 Reporting SRCs

- 6.1 Working day does not include Saturday, Sunday or Federal Holidays.

- 6.2 SRCs meeting the reporting requirements shall be reported to OPS by email to: InformationResourcesManager@dot.gov or by fax to (202) 366-7128 if not corrected or cleared within the established time.
- 6.3 Separate conditions may be described in a single report if they are closely related.
- 6.4 Gas Compliance shall concurrently submit a report to the ICC.
- 6.5 See [Appendix A](#) for preamble to Amendment 191-7 to CFR Part 191, which addresses "Interpretation and Statement of Policy Regarding Discovery of Safety-Related Conditions by Smart Pigs and Instructions to Personnel". It addresses discovery vs. determination of a condition.

7.0 Transmission MAOP Exceedance Report (49 CFR 191.25)

- 7.1 For transmission pipelines that exceed MAOP plus buildup (MEP) allowed for operation of pressure limiting or control devices, a MAOP Exceedance Report is required to be received by the PHMSA Associate Administrator *within 5 calendar days of the occurrence*. The report shall be emailed to: InformationResourcesManager@dot.gov or faxed to (202) 366-7128.
- 7.2 Gas Compliance shall file the report as outlined in 49 CFR 191.25
- 7.3 **A MEP pressure exceedance is to be reported even if the condition is corrected within the reporting timeframe and regardless of location.**
- 7.4 The reporting requirement for an exceedance is calendar days, as opposed to the basic safety-related condition requirement of working days (that does not include Saturdays, Sundays, or federal holidays).

End of Instructions

Operator Qualification (OQ) Required?

YES

1371 Operate Gas Pipeline – System Control Center Operations

Appendices

[Appendix A - Preamble Statement \(Amendment 191-7 to 49 CFR §191.25\)](#)

Attachments

[Attachment 1 - Determination of Reporting Requirements for Safety-Related Conditions for Pipeline Facilities Other Than Underground Natural Gas Storage Facilities.](#)

[Attachment 2 – Determination of Reporting Requirements for Safety-Related Conditions for Underground Natural Gas Storage Facilities.](#)

Compliance Requirements

49 CFR §191.23 Reporting safety related conditions.

49 CFR §191.25 Filing safety-related condition reports.

Advisory Bulletin: OPS ADB-2012-11: Reporting of Exceedances of Maximum Allowable Operating Pressure, published in Vol. 77 FR page 75699 on December 21, 2012

Illinois Commerce Commission (ICC) Title 83, Public Utilities, Part 590, Minimum Safety Standards for Transportation of Gas and for Gas Pipeline Facilities, available online [here](#).

Reference Documents

Amendment 191-7 to 49 CFR §191.25, published in Vol. 54, FR page 32342 on August 7, 1989

49 CFR Part 191, Amdt. 191-26 published 84 FR 52180, Oct. 1, 2019

ANSI GPTC Z380.1-2018 (Catalog Number Z380118) - Current edition with addenda, Guide for Gas Transmission, Distribution, and Gathering Piping Systems by Gas Piping Technology Committee: Guide Material Appendix G-191-3

Document Rescission

SAFT 1 Safety Related Conditions: Requirements, October 1, 2021

Revision Notes

Location of Changes	Summary of Changes
2.0 Scope – Attachment 1	Updated – Determination of Reporting Requirements for Safety-Related Conditions for Pipeline Facilities Other Than Underground Natural Gas Storage Facilities.
2.0 Scope – Attachment 2	New - Determination of Reporting Requirements for Safety-Related Conditions for Underground Natural Gas Storage Facilities.
Paragraph 4.1.3	Updated – Refer to Attachment 1 Determination of Reporting Requirements for Safety- Related Conditions for Pipeline Facilities Other Than Underground Natural Gas Storage Facilities for determining the requirements to report SRCs to PHMSA and the ICC
Paragraph 4.1.4	New - Refer to Attachment 2 Determination of Reporting Requirements for Safety-Related Conditions for Underground Natural Gas Storage Facilities for determining the requirements to report SRCs to PHMSA, and IDNR
Paragraph 4.2.6	Simplified - A pipeline leak that constitutes an emergency.
Attachments	Updated: Attachment 1 - Determination of Reporting Requirements for Safety-Related Conditions for Pipeline Facilities Other Than Underground Natural Gas Storage Facilities. Attachment 2 Determination of Reporting Requirements for Safety-Related Conditions for Underground Natural Gas Storage Facilities

Appendix A - Preamble Statement

The preamble to Amendment 191-7* ("Interpretation and Statement of Policy Regarding Discovery of Safety-Related Conditions by Smart Pigs and Instructions to Personnel") states:

"Discovery of a potentially reportable condition occurs when an operator's representative has adequate information from which to conclude the probable existence of a reportable condition. An operator would have adequate information for each anomaly that is physically examined. Absent physical examination, discovery may occur after the data are calibrated if the "adequate information" test is met. However, the adequacy of the information that pig data provide about anomalous conditions is contingent on a concurrent indication from a number of factors from which an operator could conclude the probable existence of a reportable condition. Among these are the sophistication of the pig being used, the reliability of the data, the accuracy of data interpretation, and any other factors known by the operator relative to the condition of the pipeline."

* Reference Amendment 191-7 to 49 CFR §191.25, published in Vol. 54, FR page 32342 on August 7, 1989.

SAFT 1: Attachment 1

DETERMINATION OF REPORTING REQUIREMENTS FOR SAFETY-RELATED CONDITIONS FOR PIPELINE FACILITIES OTHER THAN UNDERGROUND NATURAL GAS STORAGE FACILITIES^{1,2,3}

Location	Time Factor	Type	Effect on Facility Operation	Report Required ¹
Within 220 yards of a building intended for human occupancy or outdoor place of assembly or within the right-of-way of an active railroad, street or highway	Will not be corrected within 5 working days ³ after determination <u>or</u> 10 working days ³ after discovery, whichever comes first	General Corrosion	Causes the MAOP to be reduced	Yes ⁴
			Does not cause the MAOP to be reduced	No
		Localized Corrosion Pitting	Leakage might result	Yes ⁴
			Leakage unlikely to result	No
		Unintended Movement or Loading	Impairs serviceability	Yes
			Does not impair serviceability	No
		Material Defect or Damage	Impairs serviceability	Yes ⁴
			Does not impair serviceability	No
		Malfunction or Operating Error	Causes pressure to increase above MAOP + allowable buildup	Yes ²
			Does not cause pressure to increase above MAOP + allowable buildup	No
		Leak	Creates an emergency	Yes
			Does not create an emergency	No
		All Other Conditions	Could lead to an imminent hazard and causes a) 20% or more pressure reduction <u>or</u> b) shutdown	Yes
			All others	No

	Will be corrected within 5 working days ³ after determination or 10 working days ³ after discovery, whichever comes first	General Corrosion	Causes the MAOP to be reduced		Yes ⁴	
			Does not cause the MAOP to be reduced		No	
		Localized Corrosion Pitting	Leakage might result	Effectively coated & cathodically protected	No	
				All other coating/cathodic protection conditions	Yes ⁴	
		Leakage unlikely to result		No		
All Other	All	No				

All Other Areas No SRC Report Required, however, see Note 2 below.

Notes:

- 1 An event which has been reported as an incident (191.5) is not reportable as a safety-related condition. Report is not required for any safety-related condition that exists on a master meter system or a customer-owned service line.
- 2 For transmission facilities that have exceeded MAOP plus buildup allowed for operation of pressure limiting or control devices, **a MAOP Exceeding Report is required to be reported within 5 calendar days**. All such MAOP exceedances on transmission facilities must be reported regardless of location or time factor relative to condition correction, See guide material under 191.23.
- 3 Working day does not include Saturday, Sunday, or federal holidays.
- 4 Does not pertain to pipelines operating at less than 20% SMYS.

Note: From ANSI GPTC Z380.1-2018 (Catalog Number Z380118), Guide for Gas Transmission, Distribution, and Gathering Piping Systems by Gas Piping Technology Committee (© American Gas Association, reprinted with permission); update pending

SAFT 1: Attachment 2

DETERMINATION OF REPORTING REQUIREMENTS FOR SAFETY-RELATED CONDITIONS FOR UNDERGROUND NATURAL GAS STORAGE FACILITIES

Location	Time Factor	Type	Effect on Facility Operation	Report Required ¹
Downhole facilities including wells, casings or wellbore tubing at an underground natural gas storage facility that connects the surface equipment with the storage reservoir	Will not be corrected by repair or replacement within 5 working days ² after determination or 10 working days ² after discovery, whichever comes first	General Corrosion of the Production Casing or Tubing	Wall thickness reduces to less than required for the maximum well operating pressure. Results in the well being removed from active service by killing the well, setting temporary plug, or some other means of stopping the connection between the well and the reservoir	Yes
			Wall thickness not reduced to less than required for maximum well operating pressure. Well can remain in service	No

		Localized Corrosion Pitting of the Production Casing or Tubing	Leakage likely to result. Results in the well being removed from active service by killing the well, setting temporary plug, or some other means of stopping the connection between the well and the reservoir	Yes
			Leakage unlikely to result and well can remain in service	No
		Unintended Movement or Loading	Impairs structural integrity or reliability of the wellhead or flow string and results in the well being removed from active service by killing the well, setting a temporary plug, or some other means of stopping the connection between the well and the reservoir	Yes
			Does not impair structural integrity or reliability and well can remain in service	No
Downhole facilities including wells, casings or wellbore tubing at an underground natural gas storage facility that connects the surface equipment with the storage reservoir	Will not be corrected by repair or replacement within 5 working days ² after determination or 10 working days ² after discovery, whichever comes first	Crack, Material Defect or Damage of the Production Casing or Tubing	Impairs structural integrity or reliability and results in the well being removed from active service by killing the well, setting a temporary plug, or some other means of stopping the connection between the well and the reservoir	Yes
			Does not impair structural integrity or reliability and well can remain in service	No
		Malfunction or Operating Error	Results in a pressure increase above the maximum well operating pressure	Yes
			Does not result in a pressure increase above the maximum well operating pressure	No
		Leak	Creates an emergency and results in the well being removed from active service by killing the well, setting a temporary plug, or some other means of stopping the connection between the well and the reservoir	Yes
			Does not create an emergency and well can remain in service	No
		All Other Conditions	Could lead to an imminent hazard and results in the well being removed from active service by killing the well, setting a temporary plug, or some other means of stopping the connec-	Yes

			tion between the well and the reservoir	
			All others: Well can remain in service	No
	Will be corrected by repair or replacement within 5 working days ² after determination or 10 working days ² after discovery, whichever comes first	All	All	No

Table 2

Table 2 Notes:	
¹	An event which has been reported as an incident (§191.5) is not reportable as a safety-related condition.
²	Working day does not include Saturday, Sunday, or federal holidays.

Note: From Guide for Gas Transmission, Distribution, and Gathering Piping Systems by Gas Piping Technology Committee (© American Gas Association, reprinted with permission);

SAFETY-RELATED CONDITIONS

October 1, 2021

SAFT 1.1 Reporting Requirements**1.0 Purpose**

This document is to ensure that reporting requirements are followed by Ameren Illinois (AIC) in alignment with 49 CFR Part 191, specifically Section §191.22, National Registry of Operators.

2.0 Scope

This document addresses the following:

[3.0 Target Audience](#)**[4.0 Reporting Requirements Related to Gas Storage and Company](#)****3.0 Target Audience**

- Gas Compliance Personnel
- Gas Superintendents
- Gas Supervisors
- Gas Storage Engineering (GSE)
- Gas Storage Field Superintendents
- Gas Storage Field Supervisors
- Gas Storage Field Operators
- Gas Control Personnel

4.0 Reporting Requirements Related to Gas Storage and Company Changes

- 4.1 Not later than 60 days before the event occurs, AIC must notify PHMSA electronically through the National Registry of Operators at <https://portal.phmsa.dot.gov> of the following events in accordance with 191.22:
- 4.1.1. Construction of any planned rehabilitation, replacement, modification, upgrade, uprate, or update of a facility, other than a section of line pipe, that costs \$10 million or more. If 60-day notice is not feasible because of an emergency, an operator must notify PHMSA as soon as practicable;
 - 4.1.2. Construction of 10 or more miles of a new pipeline;
 - 4.1.3. Construction of a new LNG plant, LNG facility, or Underground Natural Gas Storage Field (UNGSF).
 - 4.1.4. Maintenance of a UNGSF that involves the plugging or abandonment of a well, or that requires a workover rig and costs \$200,000 or more for an individual well, including its wellhead.
 1. If 60-days' notice is not feasible due to an emergency, an operator must promptly respond to the emergency and notify PHMSA as soon as practicable
- 4.2 Ameren Illinois must notify PHMSA of any of the following events not later than 60 days after the event occurs:
- 4.2.1. A change in the primary entity responsible (i.e., with an assigned OPID) for managing or administering a safety program required by this part covering pipeline facilities operated under multiple OPIDs;
 1. A change in the name of the operator.

UNCONTROLLED IF PRINTED

2. A change in the entity (e.g., company, municipality) responsible for an existing pipeline, pipeline segment, pipeline facility, UNGSF, or LNG facility;
3. The acquisition or divestiture of 50 or more miles of a pipeline or pipeline system subject to part 192.
4. The acquisition or divestiture of an existing UNGSF, or an LNG plant or LNG facility subject to part 193.
5. Changes must be communicated to with advance notice to AIC Gas Pipeline Safety Compliance who will make the notifications to PHMSA.
6. Ameren Illinois must use the Operator ID assigned by PHMSA for reporting requirements, which is 32513.

End of Instructions

Operator Qualification (OQ) Required?

YES

1371 Operate Gas Pipeline – System Control Center Operations

Appendices

NONE

Attachments

NONE

Compliance Requirements

49 CFR §191.22 National Registry of Operators

Reference Documents

NONE

Document Rescission

SAFT 1.1 Safety Related Conditions – Reporting Requirement, May 10, 2021

Revision Notes

Location of Changes	Summary of Changes
May 10, 2021	This is a new document which became effective on May 10, 2021.
Operator Qualifications	Added – 1371 – System Control Center Operations

SECR-Security Plan

SECURITY PLAN

October 1, 2020

SECR 0 Table of Contents

[SECR 1 Security Plan: Requirements](#)

Section 1.0 Purpose

Section 2.0 Scope

Section 3.0 Target Audience

Section 4.0 General

Section 5.0 Responsibilities Employees, Contractors, and Service Providers

Section 6.0 Direct Threats

Operator Qualification (OQ)

Compliance Requirements

Reference Documents

Document Rescission

Document Rescission

SECT 0 Security Plan: Table of Contents, January 1, 2016.

Revision Notes

Location of Changes	Summary of Changes
Not applicable.	This is a new document.

SECURITY PLAN

May 15, 2022

SECR 1 Requirements

1.0 Purpose

This document is to ensure that any threats of damage or disruption by outside parties are recognized and that reasonable and prudent measures are taken by Ameren Illinois (AIC) to protect its gas facilities and to maintain normal operations.

2.0 Scope

This document addresses the following:

[3.0 Target Audience](#)[4.0 General](#)[5.0 Responsibilities - Employees, Contractors, and Service Providers](#)[6.0 Direct Threats](#)**3.0 Target Audience**

- Gas Supervisors
- Gas Field Personnel
- Gas Technical Services Supervisor
- Gas Control Supervisor
- Gas Control Personnel
- Security Supervisor
- Security Personnel

4.0 General

- 4.1 Corporate Security and AIC have designated certain assets as "Critical Gas Facilities." Corporate Security maintains a list of these facilities and has identified specific risk and vulnerability control measures that will be taken should these facilities be threatened.
- 4.2 Corporate Security has an *Ameren Gas Facilities Corporate Security Plan* that outlines the appropriate risk control measures to be taken depending on Threat Alert Level for AIC.
- 4.3 The range of measures to be taken varies with specificity and severity of the threat received.

5.0 Responsibilities - Employees, Contractors, and Service Providers

- 5.1 If there is an imminent threat, such as suspicious person, activity, or device, or a credible threat, personnel should first notify local law enforcement (911) to initiate an immediate response to the suspected threat. Then, immediately call the Ameren Security Operations Center, which is staffed 24/7.
- 5.2 Any suspected or confirmed Physical Sabotage Incident must be reported immediately to the Security Operations Center (SOC) by the observing person.

Call the Decatur Security Operations Center at
(217) 424-8256.

UNCONTROLLED IF PRINTED

5.3 Actions for attention:

- 5.3.1 Employees should first act with safety in mind and then make every attempt to preserve physical evidence.

It is best to NOT touch, walk through, or disturb any evidence, unless essential for safety, until the proper authorities have arrived on scene to investigate.

- 5.3.2 Take notes - document who, what, where, when, why, and how. Document the witnesses or vehicles in the area, including license plate numbers.
- 5.3.3 When possible, take photographs of area without disturbing the scene. Photos should be preserved, and copy submitted promptly to Corporate Security.
- 5.3.4 Employees shall also follow their respective Departmental procedures, if any, for responding to such incidents or events.

6.0 Direct Threats

- 6.1 A direct threat may be received that is specifically focused on the AIC gas system. Such a threat might be received by:
 - 6.1.1 JULIE Call Center.
 - 6.1.2 Gas Control.
 - 6.1.3 Employee.
 - 6.1.4 Corporate Security.
- 6.2 A threat may be either general or specific in nature (e.g., an employee discovers a threat to facilities; statements such as "I planted bombs at 6 of your gas facilities"; or, "I planted a bomb at your XYZ gas facility").
- 6.3 When a threat is received that is directed toward the AIC gas system, it shall be communicated directly to Corporate Security.
- 6.4 Corporate Security will:
 - 6.4.1 Evaluate information and determine the appropriate AIC threat alert level.
 - 6.4.2 Notify the appropriate Gas Operations & Gas Control personnel.
 - 6.4.3 Communicate information regarding a direct threat within AIC and to outside entities, such as governmental or law enforcement agencies.
- 6.5 The Director with responsibility for the targeted area(s) will initiate the risk control measures identified in this document for the Critical Gas Facilities according to threat alert level that is determined and issued by Corporate Security.

End of Instructions.

Operator Qualification (OQ) Required?

YES

0331: Valve-Visual Inspection and Partial Operation

UNCONTROLLED IF PRINTED

1371: Operate Gas Pipeline - System Control Center Operations

1381: Operate Gas pipeline - Local Facility Remote-Control Operations

A003: Emergency Response

Appendices

NONE.

Attachments

NONE.

Compliance Requirements

NONE.

Reference Documents

49 CFR §192.615 Emergency plans.

Document Rescission

SECR 1 Security Plan: Requirements, October 1, 2020

Revision Notes

Location of Changes	Summary of Changes
Subsection 5.1	Updated – Ameren Security Operations Center
Subsection 6.5	Moved former 6.4.4 – Director's responsibility to separate Sub-section.
Reference Documents	Removed Ameren Gas Facilities Corporate Security Plan. This is not a publicly available document.

SERV-Service Line Installation

SERVICE LINE INSTALLATION

October 1, 2020

SERV 0 Table of Contents

[SERV 1 Service Line Installation: Requirements](#)

Section 1.0 Purpose

Section 2.0 Scope

Section 3.0 Target Audience

Section 4.0 Depth of Service Line

Section 5.0 Support and backfill

Section 6.0 Underground clearances

Section 7.0 Location

Section 8.0 Valve requirements (including EFV's)

Section 9.0 Main connection

Section 10.0 PE service lines

Section 11.0 Pressure testing

Section 12.0 New service lines not in use

Section 13.0 Back Flagging

Section 14.0 Records

Operator Qualification

Compliance Requirements

Reference Documents

Document Rescission

Appendices

Appendix A - Service Line Location

Appendix B - Riser and Pipe Technical Drawings

[SERV 2.1 Service Line Installation: Service Line Capacity](#)

Section 1.0 Purpose

Section 2.0 Scope

Section 3.0 Target Audience

Section 4.0 Determining Service Line Capacity

Section 5.0 Gas Service Line sizing example

UNCONTROLLED IF PRINTED

Operator Qualification

Compliance Requirements

Reference Documents

Document Rescission

Appendices

Appendix A - Gas Customer Load Information

Appendix B - Estimated Demand of Gas Appliances

Appendix C - Pressure System Classification/Allowed Pressure Drop - Services

Appendix D - Demand Diversity Factor for Appliance

Appendix E - Service Line Capacity Tables

SERV 2.2 Service Line Installation: Excess Flow Valves or Manual Shut-off Valve

Section 1.0 Purpose

Section 2.0 Scope

Section 3.0 Target Audience

Section 4.0 Requirement for EFV Installation

Section 5.0 EFV Installation and Location

Section 6.0 EFV Sizing

Section 7.0 Requirements for manual service line shut-off valve installation

Section 8.0 Manual Service Line Shut-Off Valve Installation

Section 9.0 Inspection and Maintenance of Manual Shut-Off Valve

Section 10.0 EFV and Manual Shut-Off Valve Identification

Operator Qualification

Compliance Requirements

Reference Documents

Document Rescission

Appendices

Appendix A - EFV Locations

Appendix B - EFV Sizing Tables

SERV 2.3 Service Line Installation: Farm Tap Installation

Section 1.0 Purpose

Section 2.0 Scope

Section 3.0 Target Audience

Section 4.0 Farm Tap Requirements

Section 5.0 Farm Tap Locations

UNCONTROLLED IF PRINTED

Section 6.0 Farm Tap Installations

Section 7.0 Farm Tap Capacity

Section 8.0 Inlet Valves

Section 9.0 Testing

Operator Qualification

Compliance Requirements

Reference Documents

Document Rescission

Appendices

Appendix A - Farm Taps

Appendix B - Farm Tap Location

Appendix C - Farm Tap Capacity Tables

SERV 2.4 Service Line Installation: Yardlines

Section 1.0 Purpose

Section 2.0 Scope

Section 3.0 Target Audience

Section 4.0 Yardline Definition

Section 5.0 Yardline Operation and Maintenance

Section 6.0 Yardline Installations

Section 7.0 Yardline Elimination

Section 8.0 Yardline Records

Operator Qualification

Compliance Requirements

Reference Documents

Document Rescission

SERV 2.5 Service Line Installation: Inactive Services

Section 1.0 Purpose

Section 2.0 Scope

Section 3.0 Target Audience

Section 4.0 Inactive Service Definition

Section 5.0 Maintenance of Inactive Services

Section 6.0 Tracking and Reporting of Inactive Services

Section 7.0 Inactive Service Retirements

Operator Qualification

Compliance Requirements

UNCONTROLLED IF PRINTED

Reference Documents

Document Rescission

SERV 2.6 Service Line Installation: Insertion

Section 1.0 Purpose

Section 2.0 Scope

Section 3.0 Target Audience

Section 4.0 General Requirements

Section 5.0 Tracer Wire Installation

Section 6.0 Dead Service Line Insertion Procedures

Section 7.0 Conduit or Sleeve Insertion Procedures

Operator Qualification

Compliance Requirements

Reference Documents

Document Rescission

SERV 2.7 Service Line Installation: Gas Service Card Form and Gas Sketch Card

Section 1.0 Purpose

Section 2.0 Scope

Section 3.0 Target Audience

Section 4.0 Gas Service Card Form

Section 5.0 Service Sketches

Section 6.0 Gas Sketch Card Completion Instructions

Section 7.0 Distribution - Gas Sketch Card

Operator Qualification

Compliance Requirements

Reference Documents

Document Rescission

Appendices

Appendix A - Sample - Gas Sketch Card

SERV 2.8 Service Line Installation: Gas Service G/Tech Mapping

Section 1.0 Purpose

Section 2.0 Scope

Section 3.0 Target Audience

Section 4.0 Mapping - General

UNCONTROLLED IF PRINTED

- Section 5.0 Mapping a Premise
- Section 6.0 Mapping Meter Points
- Section 7.0 Mapping a Gas Service
- Section 8.0 Mapping a Farm Tap Service
- Section 9.0 Mapping a Branch Service
- Section 10.0 Mapping a Replaced Service
- Section 11.0 Mapping a Retired Service
- Section 12.0 Mapping a Stub Service
- Section 13.0 Mapping a Transferred Service
- Operator Qualification
- Compliance Requirements
- Reference Documents
- Document Rescission

[SERV 3 Service Line Installation: Forms and Reference Materials](#)

- References
- Document Rescission

End Table of Contents.

Document Rescission

SERV 0 Service Line Installation: Table of Contents, October 1, 2019.

Revision Notes

Location of Changes	Summary of Changes
Not applicable.	This is a new document.

SERVICE LINE INSTALLATION

April 1, 2023

SERV 1 Requirements

1.0 Purpose

This document describes the requirements for installing gas service lines.

The installation of gas services must meet the minimum requirements of 49 CFR §192 Subpart H and Subpart J.

2.0 Scope

This document addresses the following

[3.0 Target Audience](#)[4.0 Depth of Service Line](#)[5.0 Support and Backfill](#)[6.0 Underground Clearances](#)[7.0 Location](#)[8.0 Valve Requirements \(including EFV's\)](#)[9.0 Main Connection](#)[10.0 PE Service Lines](#)[11.0 Pressure Testing](#)[12.0 New service Lines not in Use](#)[13.0 Back Flagging](#)[14.0 Records](#)

Appendices

[Appendix A - Service Line Location](#)[Appendix B - Riser and Pipe Technical Drawings](#)**3.0 Target Audience**

- Gas Engineering
- Gas Distribution Design Specialist
- Field Engineering Representatives
- Gas Field Personnel
- Gas Supervisors
- Gas Construction Services personnel

4.0 Depth of Service Line (49 CFR §192.361)

4.1 Service line depth for service lines smaller than 2 inch shall be a minimum of 18 inches from top of pipe to finished grade and should be a minimum of 24 inches for service lines 2 inch and larger on:

- 4.1.1 Private property
- 4.1.2 Public streets
- 4.1.3 Public roads

UNCONTROLLED IF PRINTED

Or

4.1.4 Depth listed on any easement or highway, railroad or street permit

Service lines 2 inch and larger, the minimum depth of cover as the service line approaches the service riser will be determined by the maximum bury depth shown on the service riser.

4.2 Service Tees shall have a minimum depth of 24 inches cover.

4.3 When the above minimums cannot be maintained the following actions shall be taken:

4.3.1 Service tee: Safety Barrier Tape shall be installed approximately twelve (12) inches below the surface to provide advance warning to excavators.

4.3.2 Service line: Safety Barrier Tape shall be installed approximately six (6) inches below the surface to provide advance warning to excavators.

4.3.3 Note location of service lines buried with less than 18 inches of cover on the Gas Service Card Form within ClickMobile.

4.4 Underground structure conflicts with service line location

4.4.1 Contact Gas Supervisor for remedy

1. Relocate to a location where 18 inches can be achieved
2. If relocation not possible, then
3. Contact Engineering for design changes to protect the service line from external loads, such as:
 - 3 a. Inserting plastic service line inside metallic pipe.
 - 3 b. Install concrete pad above the service line, with four (4) inch spacing between the pad the service line.

4.5 Service lines shall be installed at a depth which will protect them from:

4.5.1 Excessive external loading

4.5.2 Local activities such as:

1. Loaded truck traffic
2. Material storage
3. Gardening or farming operations

4.6 Prior to plowing or boring in a service line:

4.6.1 Inspect the proposed service line route for public and privately buried facilities such as sewer laterals, water lines, electric power lines, telephone lines, and CATV lines that may conflict with the gas service line.

4.6.2 Buried facilities that cross or are with eighteen (18) inches of the proposed plow path should be exposed or verified not to be in conflict with the plow path and depth.

5.0 Support and Backfill (49 CFR §192.361)

5.1 Support

- 5.1.1 Each gas service line must be properly supported on undisturbed or well-compacted soil or sand.
- 5.1.2 Bridging, sleeving, granular fill (screened granular material less than or equal to ¼ inch) or other suitable methods shall be used to support pipe installed in or across previously excavated areas or in unstable soil

5.2 Backfill

5.2.1 Service lines smaller than 2 inches in diameter

- 1. First, a minimum layer must be installed, approximately six (6) inches thick, of:
 - 1 a. Clean construction material
 - 1 b. Granular material equal to or less than ¼ inch
or
 - 1 c. Sand

If suitable material is not available to initially cover the pipe, a rock shield such as Tuff-N-Nuff or a rigid sleeve can be installed around the service line may be used in lieu of material listed in 5.2.1 1 1a, 1b, or 1c.

- 1 d. Gas engineering may specify other approved means or materials that can be used.

Then

- 2. Excavated material containing rock, gravel or cinders is placed in the excavation.
- ### 5.2.2 Service lines two (2) inches and larger
- 1. Backfilling should be done in the same manner as a gas main. Refer to [MAIN 1](#).
- ### 5.2.3 Excavated material used for backfill must be free of:
- 1. Rocks larger than two (2) inches
 - 2. Construction debris
 - 3. Concrete or asphalt chunks
 - 4. Brush
 - 5. Pipeline Skids
 - 6. Other materials that could damage the pipe or its coating

6.0 Underground Clearances

- 6.1 Twelve (12) inches of underground clearance must be maintained vertically or horizontally between service lines and buried electric lines or steam pipes.

If the minimum clearance is not possible, a shield such as a sleeve, Tuff-N-Nuff, rubber matting, fiberglass or PVC shield or a casing pipe should be installed around the service line.

Note the reduced clearance in the comment section on the Gas Service Card Form within ClickMobile.

- 6.2 Six (6) inches between service lines and other buried utilities, water, sewer, telephone or CATV.
- 6.3 See [MAIN 2.1](#) Joint Trench Installation for additional clearances associated with joint trench installations

7.0 Location

7.1 Services

- 7.1.1 New residential service lines should be installed on the most direct route from the main to the proposed meter location. (Refer to Appendices [A-1](#) and [A-2](#)).
- 7.1.2 New, relocated, or replaced service lines shall not be installed under buildings unless:
 1. Installation is approved by Gas Engineering, AND
 2. Service line is installed in a gastight casing to prevent gas leakage into the building, AND
 3. Service line and casing must extend into a normally usable and accessible part of the building, AND
 4. The casing vented to a nonhazardous atmosphere outside the building with a rain or insect resistant fitting.

7.2 Branched Service

- 7.2.1 Any branch service, installed on or after October 1, 2022, shall only serve 2 service risers from a single service line tap.
- 7.2.2 Each of the service lines shall meet the same requirements as a single service line.
- 7.2.3 [SERV 2.2 Paragraph 4.1.2](#) addresses EFV requirements for branch services.

7.3 Service Risers

- 7.3.1 The preferred location for the meter riser is within 2 to 5 feet of the front corner of the structure as long as the clearance requirements in Table 1 "Meter Riser Clearance Requirements" can be achieved.
- 7.3.2 Alternate location requires Supervising Engineer approval.
- 7.3.3 A plastic sleeve should be installed around newly installed gas risers that are planned to be encased in a hard surface. The sleeve should extend above the hard surface.

Table 1 Meter Riser Clearance Requirements

Activity	Located within 2-5 feet from front corner	12 inches from windows and/or vents	3 feet from source of ignition	Under Fire Escapes or Downspouts ¹
New Home Construction	Yes	Yes	Yes	No
Conversion from Propane	Not Required	Yes	Yes	No
Conversion from Electric	Not Required	Yes	Yes	No
Replace existing service	Not Required	Yes	Yes	No
Relocate Riser/Meter	Not Required	Yes	Yes	No
Riser Replacement	Not Required	Yes	Yes	No
Relocate Portion of Service	Not Applicable	Not Applicable	Not Applicable	Not Applicable

1. Refer to [METR 1](#)
- 7.3.4 Gas meter can be installed on the front side of the home if agreed upon by and the property owner.
- 7.3.5 Meter riser locations for the following should be located in accordance with Table 1 "Meter Riser Clearance Requirements".
 1. Propane/electric conversion
 2. Existing service line that is being replaced or relocated
 3. Existing service riser being replaced
- 7.3.6 Areas of where settlement can occur due to disturbed or uncompact soil:
 1. Install a flex riser and house bracket
Or
 2. Meter stake
 3. Refer to Appendix [B-1](#) or [B-3](#) for more information.
- 7.3.7 A rigid riser should be considered if:
 1. Ground conditions are stable and settling is not anticipated. (Refer to Appendices [B-2](#) or [B-4](#) for more information).
- 7.3.8 A rigid riser with either a house bracket or meter stake should be used for a multiple meter header. Decision is based on field conditions.
- 7.3.9 Flex or rigid riser modification:
 1. Casing pipe on flex or rigid riser should not be shortened under any circumstances due to the potential of damaging the carrier pipe.
 2. The riser's twelve (12) inch pigtail can be shortened but there must sufficient length remaining to allow for proper installation of the electrofusion coupling.
- 7.3.10 Residential service riser location is determined based on ensuring the gas meter set location has taken into consideration:
 1. Public safety

2. Sources of ignition
3. Possible air intakes into a building

7.4 Meters

- 7.4.1 Refer to Ameren document [METR 1](#).

8.0 Valve Requirements (including EFV's) (49 CFR §§ 192.363, 192.365, 192.383)

8.1 New service line valve requirement

8.1.1 Meter Valves

- 1 a. Single meter location
 - (i) Valve shall be lockable
 - (ii) Valve shall be located before the regulator and meter
- 1 b. Multiple meter location
 - (i) Valve shall be lockable
 - (ii) Valves shall be located before each meter
- 1 c. Inaccessible meter valves
 - (i) If the meter valve(s) are not readily accessible, a second readily accessible valve shall be installed.
 - (ii) A manual service line shut-off valve installed at the property line will meet this requirement.

8.1.2 Excess Flow Valve (EFV)

1. Refer to [SERV 2.2](#) Service Line Installation: Excess Flow Valves or Manual Shut-off Valves for specific requirements and exceptions.

8.2 Existing service line valve requirements

8.2.1 If service line doesn't have an outside service line shutoff valve

1. Valve shall be installed any time there is construction on the service line.
2. The valve must be in a readily accessible location for safe operation of the valve.
3. If installed below ground, must be in a covered durable valve box that is supported independently of the service line.

9.0 Main Connection (49 CFR §192.367)

9.1 All service line to main connections shall be located:

9.1.1 On top of the main

If not practical, then

9.1.2 Side of the main

or

9.1.3 Bottom-out fitting if suitable protection is provided to minimize the possibility of dust and moisture being carried from the main into the service line.

10.0 PE Service Lines (49 CFR §192.321 49 CFR §192.375)

10.1 PE Service Line installation

10.1.1 PE service line must be permanently installed below ground

10.1.2 PE service line may terminate above ground level if its:

1. Installed in an anodeless steel service riser.
2. Protected against deterioration and external damage.
3. Not used to support external loads.

10.1.3 PE service lines shall not be installed inside a building.

10.1.4 PE service lines must be installed so as to minimize shear or tensile stresses.

10.1.5 PE service lines that are not encased must have an electrically conductive wire or other means of locating the underground pipe.

1. The tracer wire should not be wrapped around or taped to the pipe.
2. Contact with the pipe should be minimized but is not prohibited.

10.2 PE service lines installed in a vault or pit must be:

10.2.1 Completely encased in a gas tight metal pipe and with fittings that are adequately protected from corrosion.

10.3 PE service pipes installed in a conduit must be:

10.3.1 Inserted into the conduit pipe in a manner that will protect the pipe. Refer to [SERV 2.6 Section 7.0](#) Conduit and Sleeve Insertion Procedures

10.3.2 The leading end of the PE pipe must be closed before insertion.

10.4 Service lines installed by plowing or boring.

10.4.1 Refer to [Section 4.6](#) of this document, [BORE 2.1](#) - Pipe Installation, and [POLY 1](#).

10.5 Standard residential service line installation is 1" CTS. 1/2" CTS service lines should only be installed for the following reasons and with engineering approval:

10.5.1 Insertion into an existing steel service line. Refer to [SERV 2.6](#) Insertion.

10.5.2 Repair or replacement of an existing service line.

10.5.3 Service line installation for a mobile home.

11.0 Pressure Testing (49 CFR §192.511, §192.513)

11.1 All of the following shall be pressure tested in accordance with [PTST 1 Section 10.0](#) Testing:

11.1.1 New service lines

11.1.2 Replaced service lines

11.1.3 Reinstated service lines

11.1.4 Transferred service lines

11.2 Partially replaced service lines

11.2.1 The replaced portion of the service shall be pressure tested.

UNCONTROLLED IF PRINTED

11.2.2 The portion of the service from the point of disconnect to the meter valve shall be pressure tested.

11.3 Service line being pressure tested shall be disconnected from the meter set or customer piping while the line is under test, until the test pressure has been released.

11.4 The results of the pressure test shall be recorded on the Service Card in ClickMobile.

11.5 Refer to [PTST 1](#) Pressure Testing: Requirements for pressure testing requirements and [RNST 1](#) for reinstating of service lines.

12.0 New service Lines not in Use (49 CFR §192.379)

12.1 Each service line not placed in service upon completion of installation must comply with one of the following until customer is supplied with gas:

12.1.1 Install a locking device in the closed valve to prevent opening of the valve by unauthorized persons.

12.1.2 Install a mechanical device or fitting that will prevent the flow of gas.

12.1.3 Disconnect the customer's piping from the gas supply and seal the open pipe ends.

13.0 Back Flagging

13.1 Newly installed AIC gas facilities shall be "back-flagged" as stated in [DAMG 1 Section 11.0](#)

14.0 Records

14.1 The following shall be recorded on the Gas Service Card form within ClickMobile:

14.1.1 Service Line installations

14.1.2 Service Line repairs

14.1.3 Service Line retirements

14.2 All completed Gas Service Cards recorded with ClickMobile shall be retained within Maximo.

14.3 Gas Services shall be mapped in the electronic mapping system within ninety (90) days after submittal to the Poster. (Refer to [SERV 2.8](#) Gas Service G/Tech Mapping)

End of Instructions.

Operator Qualification (OQ) Required?

YES

0561: Pressure Test - Nonliquid Medium- MAOP Less than

0591: Leak Test at Operating Pressure

0901: Installation of Plastic Pipe in a Ditch

0981: Backfilling

1291: Locate Underground Pipelines

1341: Provide or Assure Adequate Pipeline Support During Operator Initiated Excavation Activities

UNCONTROLLED IF PRINTED

A001: Service Reconnect

A002: Abandonment

Appendices

Appendix A - Service Line Location

Appendix B - Riser and Pipe Technical Drawings

Attachments

NONE.

Compliance Requirements

49 CFR §192.361 Service lines: Installation.

49 CFR §192.363 Service lines: Valve requirements.

49 CFR §192.365 Service lines: Location of valves.

49 CFR §192.367 Service lines: General requirements for connections to main piping.

49 CFR §192.375 Service lines: Plastic.

49 CFR §192.379 New service lines not in use.

49 CFR §192.383 Excess flow valve installation.

49 CFR §192.511 Test requirements for service lines.

Reference Documents

[BORE 2.1 Boring Operations and Pipe Installation](#)

[DAMG 1 Damage Prevention: Requirements](#)

[MAIN 1 Main Installation: Requirements](#)

[MAIN 2.1 Main Installation: Joint Trench Installation](#)

[METR 1 Metering: Requirements](#)

[POLY 1 Polyethylene Pipe: Requirements](#)

[PTST 1 Pressure Testing: Requirements](#)

[RNST 1: Reinstating of Facilities: Requirements and Reinstating mains and Services](#)

[SERV 2.2 Service Line Installation: Excess Flow Valves or Manual Shut-Off Valve](#)

[SERV 2.8 Service Line Installation: Gas Service G/Tech Mapping](#)

[TURN 2.1 Turn-On Turn-Off: Residential/Small Commercial Customer](#)

Document Rescission

SERV 1 Service Line Installation: Requirements, October 1, 2022

Revision Notes

Location of Changes	Summary of Changes
---------------------	--------------------

UNCONTROLLED IF PRINTED

Paragraph 7.3.3 – Service Riser	New - A plastic sleeve should be installed around newly installed gas risers that are planned to be encased in a hard surface. The sleeve should extend above the hard surface.
Appendix A-3 – Residential Meter Set Locations Restrictions	Replaced the picture with the one from AIC's Gas Service Installation brochure.
Appendix B-1 – ½" PE Service Line, Flex Riser – Installation	Removed reference to PE2406/PE2708 since AIC no longer purchases 1/2"CTS PE2406/PE2708 pipe. All 1/2"CTS service lines are now PE4710 pipe.
Appendix B-1 – ½" PE Service Line, Flex Riser – Material Tables	Eliminated the PE2406/PE2708 table, Expanded the PE4710 Table to include the larger service tees that were in the PE2406/PE2708 table. Removed PE3408 from the Table.
Appendix B-2 – ½" PE Service Line, Rigid Riser – Installation	Removed reference to PE2406/PE2708 since AIC no longer purchases 1/2"CTS PE2406/PE2708 pipe. All 1/2"CTS service lines are now PE4710 pipe.
Appendix B-2 – ½" PE Service Line, Rigid Riser – Material Tables	Eliminated the PE2406/PE2708 table, Expanded the PE4710 Table to include the larger service tees that were in the PE2406/PE2708 table. Removed PE3408 from the Table.
Appendix B-3 – 1" PE Service Line, Flex Riser – Installation	Update pipe designation to PE2708 and PE4710 to match Performance Pipe designation. Grammatical change – PE4710 service line shall be utilized on 1-inch service lines with an MAOP of between 61 and 125 psig, PE4710 can also be used in systems with MAOP less than 61 psig.
Appendix B-3 – 1" PE Service Line, Flex Riser – Material Lists	Removed PE3408 from the Table.
Appendix B-4 – 1" PE Service Line, Rigid Riser – Installation	Update pipe designation to PE2708 and PE4710 to match Performance Pipe designation. Grammatical change – PE4710 service line shall be utilized on 1-inch service lines with an MAOP of between 61 and 125 psig, PE4710 can also be used in systems with MAOP less than 61 psig.
Appendix B-4 – 1" PE Service Line, Rigid Riser – Material List	Removed PE3408 within the tables
Appendix B-5 – 2" PE Service Line, Rigid Riser - Installation	Update pipe designation to PE2708 and PE4710 to match Performance Pipe designation. Added Note 10. The EFV shall be installed in accordance with SERV 2.2 Excess Flow Valves or Manual Shut-off Valves.

Appendix B-5 – 2" PE Service Line, Rigid Riser -Material List	Removed PE3408 within the tables.
---	-----------------------------------

Appendix A - Service Line Location

A-1. Standard Service Line Location

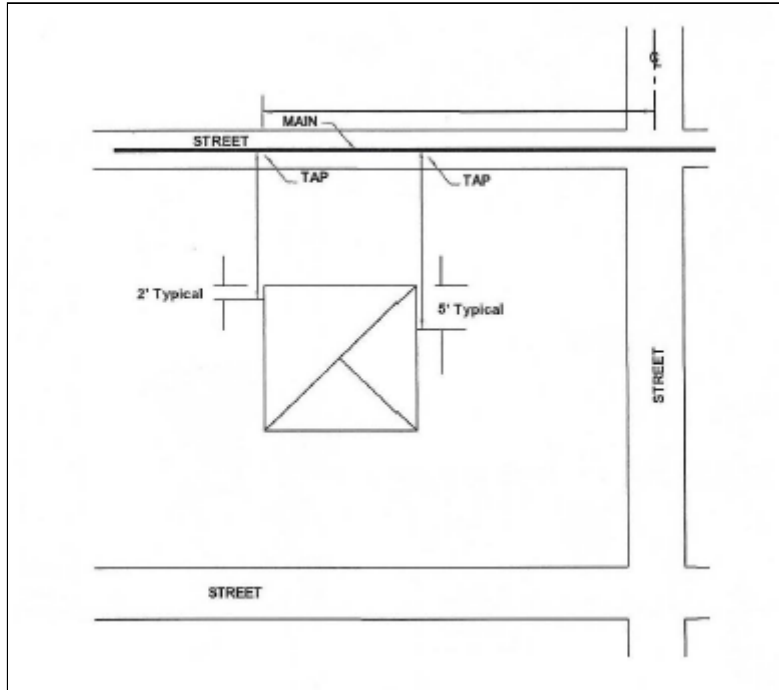

A-2. Standard Residential Farm Tap Service Line Location

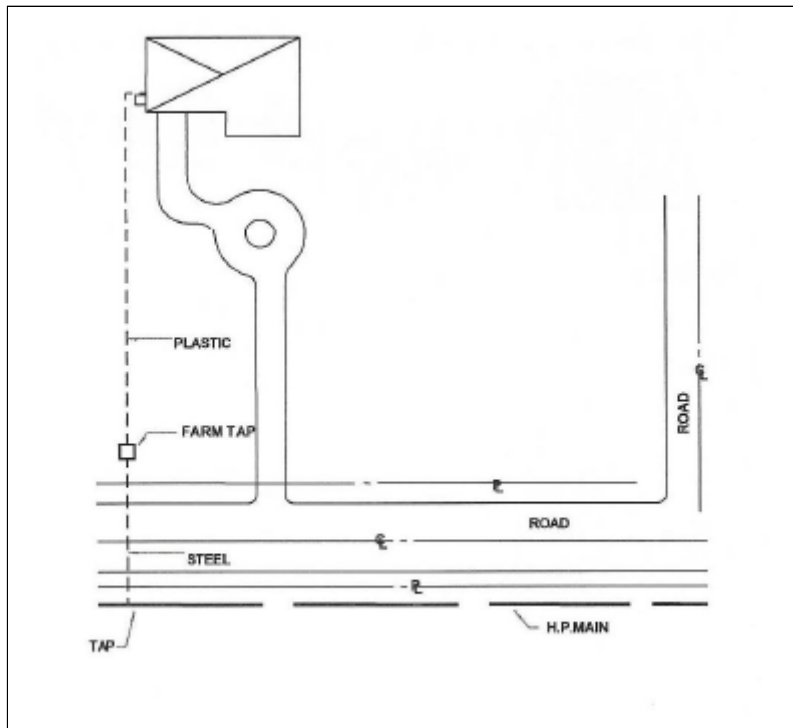

A-3. Residential Meter Set Locations Restrictions

Meter Location on Right Side of House

Meter Location on Left Side of House

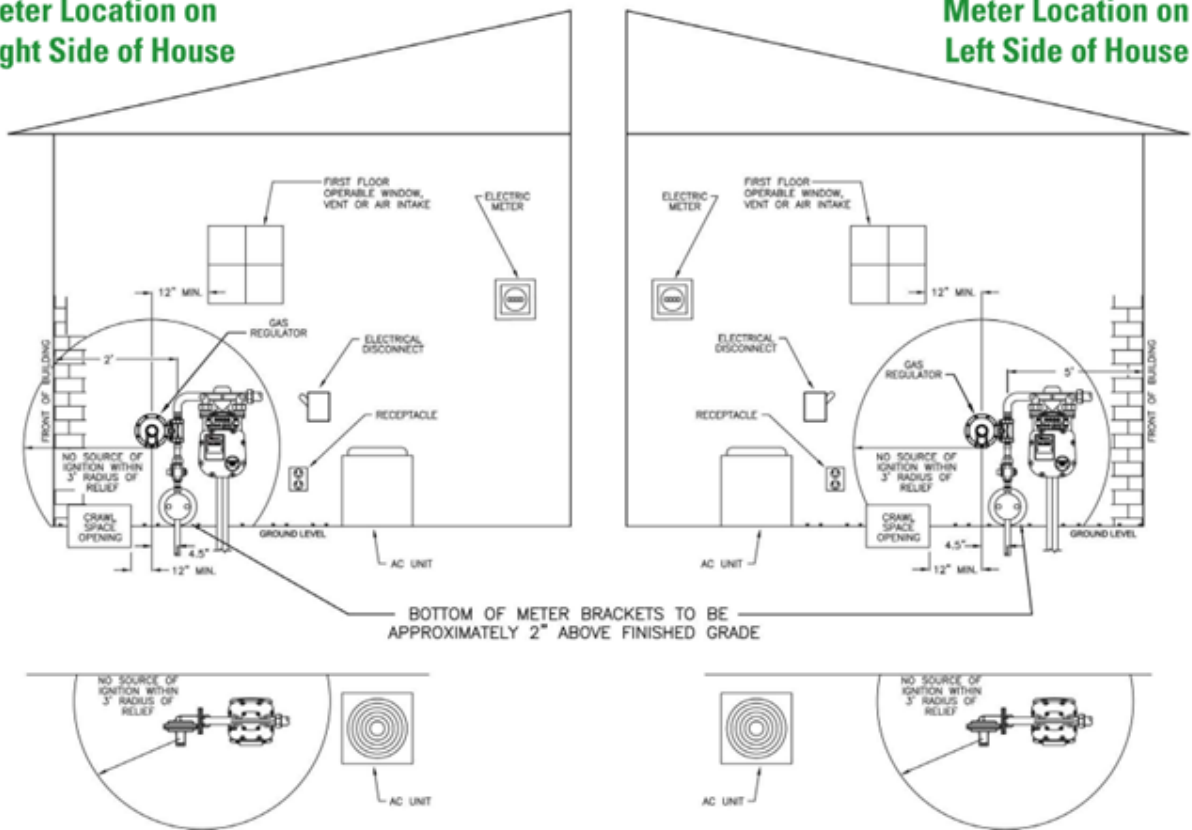

Note: A 15 feet horizontal radius from the relief vent is required for gas risers greater than 2" IPS (2.375 inches in diameter).

Appendix B - Riser and Pipe Technical Drawings

B-1. 1/2" PE Service Line, Flex Riser

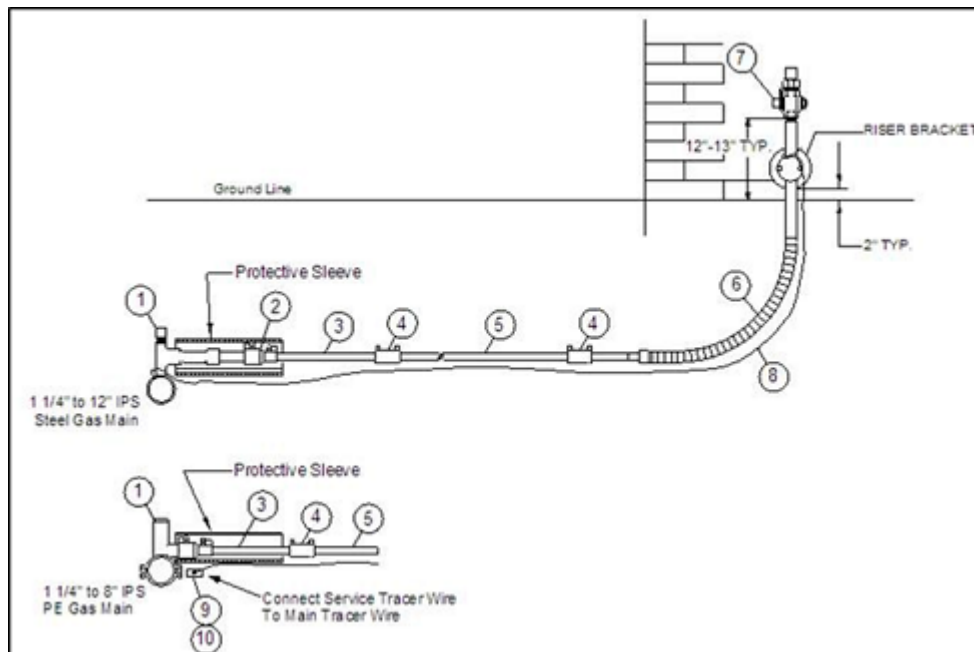

Installation

1. PE4710 service line is utilized for all 1/2-inch PE service lines with a MAOP of 125 psig or less.

2. The EFV shall be installed in accordance with [SERV 2.2](#).
3. A protective sleeve [POLY 3.1 Appendix B](#), shall be placed over the connection between the tee and the service pipe.
4. The flexible portion of the riser shall not be bent more than the minimum bending radius of the PE pipe specified in [POLY 1](#).
5. A meter stake should be used where conditions do not allow for the use of a riser bracket.
6. The tracer wire should be taped to the riser and a 12" pigtail brought up next to the riser bracket. If additional protection is needed, the tracer wire may be brought up through a short section of ½" PE tubing taped to the riser.
7. The bottom of the riser bracket should be installed 2" above final grade.
8. The riser should typically be placed 8" from the foundation.
9. The tracer wire shall be attached to steel mains and the connection coated in accordance with [CORR 2.8 Appendix B](#).

PE 4710 - High Density PE Pipe - (Black) (G3153##)										
Item	Main Type	Stock No.	Description	Quantity						
				01	25	02	03	04	06	08
1	Steel	19 12 597	Tee, Service, 3/4" Weld Inlet, 1" CTS Outlet	1						
	PE	19 22 400	Tee, Service, 1-1/4" IPS X 1/2" CTS, Electrofusion PE4710		1					
		19 22 401	Tee, Service, 2" IPS X 1/2" CTS, Electrofusion, PE4710			1				
		19 22 402	Tee, Service, 3" IPS X 1/2" CTS, Electrofusion, PE4710				1			
		19 22 403	Tee, Service, 4" IPS X 1/2" CTS, Electrofusion, PE4710					1		
		19 22 404	Tee, Service, 6" IPS X 1/2" CTS, Electrofusion, PE4710						1	
		19 22 398	Tee, Service, 8" IPS X 1/2" CTS, Electrofusion, PE4710							1
2		19 22 508	Coupling, Pipe, 1/2" CTS X 1" CTS, Electrofusion, PE4710	1						
3		39 22 097	Valve, Excess Flow, 1/2" CTS, 0.090 Wall, PE4710	1	1	1	1	1	1	
4		19 22 505	Coupling, Pipe, 1/2" CTS, Electrofusion, PE4710	2	2	2	2	2	2	
5		32 22 018	Pipe, PE4710, 1/2" CTS, 0.090 Wall	X	X	X	X	X	X	
6		19 17 003	Riser, Service, 3/4" IPS Outlet X 1/2" CTS, Partial Flex, Anodeless, PE4710, SDR 7.0	1	1	1	1	1	1	
7		39 01 078	Valve, Meter, Insulating, 3/4" IPS	1	1	1	1	1	1	
8		18 66 369	Wire, Tracer, #12 AWG, Cu	X	X	X	X	X	X	

UNCONTROLLED IF PRINTED

9	17 54 842	Connector, Split Bolt, Copper, #16 to #10	1	1	1	1	1	1
10	49 62 001	Box Splice, Plastic	1	1	1	1	1	1

X - Number of feet required for specific installation.

B-2. 1/2" PE Service Line, Rigid Riser

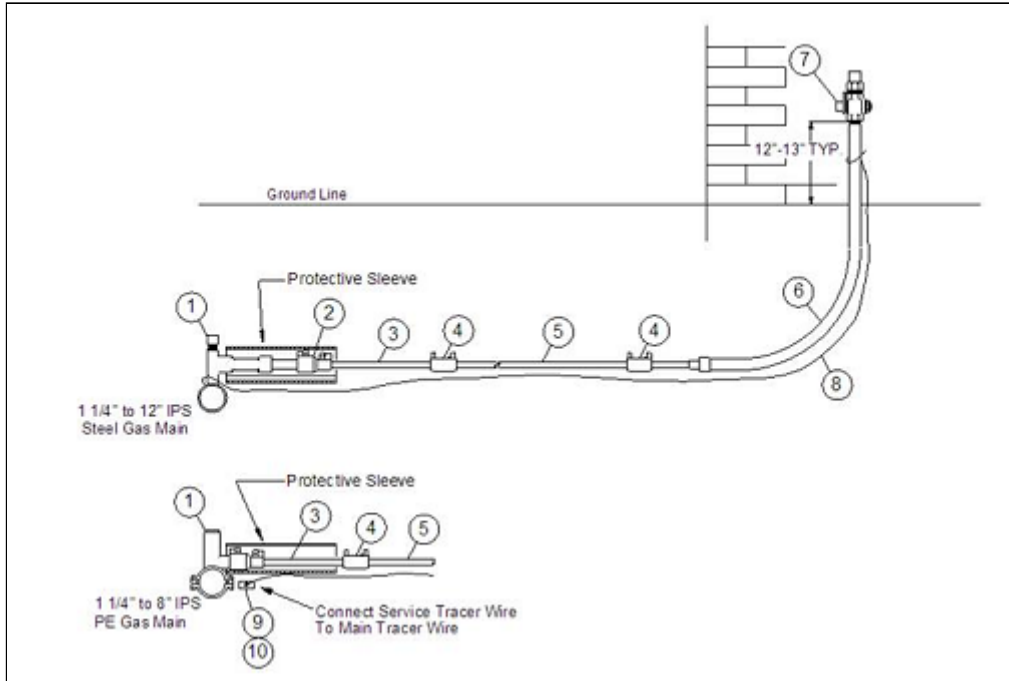

Installation

1. PE4710 service line is utilized on all 1/2-inch PE service lines with a MAOP of 125 psig or less.
2. The EFV shall be installed in accordance with [SERV 2.2](#).
3. A protective sleeve, [POLY 3.1 Appendix B](#), shall be placed over the connection between the tee and the service pipe.
4. The flexible portion of the riser shall not be bent more than the minimum bending radius of the PE pipe specified in [POLY 1](#).
5. The tracer wire should be taped to the riser and a 12" pigtail brought up next to the riser bracket. If additional protection is needed, the tracer wire may be brought up through a short section of 1/2" PE tubing taped to the riser.
6. The riser should typically be placed 8" from the foundation.
7. The tracer wire shall be attached to steel mains and the connection coated in accordance with [CORR 2.8 Appendix B](#).
8. A riser bracket (62-54-019) or meter post (62-54-287) should be installed if the meter set assembly is not tied into the customer piping or a multiple meter header is installed.

PE 4710 - High Density PE Pipe - (Black) (G3163##)								
Item	Main Type	Stock No.	Description	Quantity				
				01	25	02	03	04

1	Steel	19 12 597	Tee, Service, 3/4" Weld Inlet, 1" CTS Outlet	1							
	PE	19 22 400	Tee, Service, 1-1/4" IPS X 1/2" CTS, Electrofusion PE4710		1						
		19 22 401	Tee, Service, 2" IPS X 1/2" CTS, Electrofusion, PE4710			1					
		19 22 402	Tee, Service, 3" IPS X 1/2" CTS, Electrofusion, PE4710				1				
		19 22 403	Tee, Service, 4" IPS X 1/2" CTS, Electrofusion, PE4710					1			
		19 22 404	Tee, Service, 6" IPS X 1/2" CTS, Electrofusion, PE4710						1		
		19 22 398	Tee, Service, 8" IPS X 1/2" CTS, Electrofusion, PE4710							1	
2		19 22 508	Coupling, Pipe, 1/2" CTS X 1" CTS, Electrofusion, PE4710	1							
3		39 22 097	Valve, Excess Flow, 1/2" CTS, 0.090 Wall, PE4710	1	1	1	1	1	1	1	
4		19 22 505	Coupling, Pipe, 1/2" CTS, Electrofusion, PE4710	2	2	2	2	2	2	2	
5		32 22 018	Pipe, PE4710, 1/2" CTS, 0.090 Wall	X	X	X	X	X	X	X	
6		19 17 185	Riser, Service, 3/4" IPS Outlet X 1/2" CTS, Rigid, Anodeless, PE4710, SDR 7.0	1	1	1	1	1	1	1	
7		39 01 078	Valve, Meter, Insulating, 3/4" IPS	1	1	1	1	1	1	1	
8		18 66 369	Wire, Tracer, #12 AWG, Cu	X	X	X	X	X	X	X	
9		17 54 842	Connector, Split Bolt, Copper, #16 to #10		1	1	1	1	1	1	
10		49 62 001	Box Splice, Plastic		1	1	1	1	1	1	

X - Number of feet required for specific installation.

B-3. 1" PE Service Line, Flex Riser

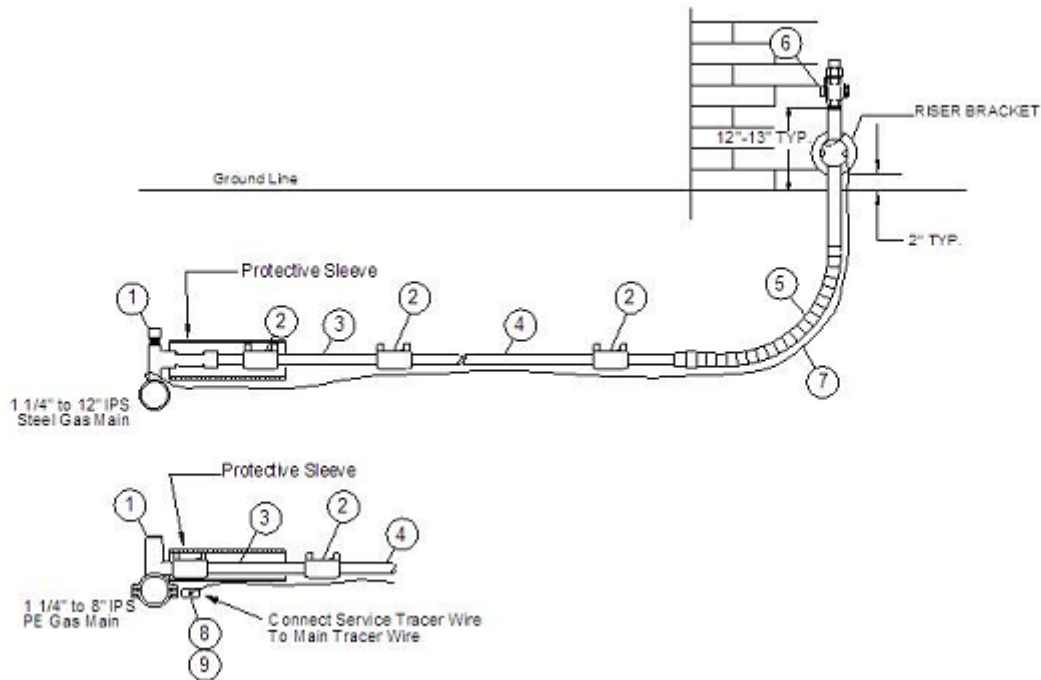

Installation

1. PE2708 service line shall be utilized on distribution systems with a MAOP between 0 and 60 psig.
2. PE4710 service line shall be utilized on **1-inch service lines** with a MAOP between 61 and 125 psig. **PE4710** can also be installed in systems with MAOP less than 61 psig.
3. PE4710 service line shall require a **PE4710** riser that is SDR 7.0, Stock Number 19 72 139
4. PE2708 riser shall not be used on a PE4710 service.
5. Caution: Electrofusion coupling is the **ONLY** approved means of connecting PE4710 service line, wall thickness 0.101, equivalent to SDR 11.1 with the PE4710 riser, SDR 7. Butt fusion is not allowed when connecting two pipe sections with a wall thickness difference that exceeds one SDR value.
6. The EFV shall be installed in accordance with [SERV 2. 2.](#)
7. The EFV can be butt fused to the service tee outlet and the PE 2708 or PE 4710 service line.
8. A protective sleeve, [POLY 3.1 Appendix B.](#) shall be placed over the connection between the tee and the service pipe.
9. The flexible portion of the riser shall not be bent more than the minimum bending radius of the PE pipe specified in [POLY 1.](#)
10. A meter stake should be used where conditions do not allow for the use of a riser bracket.
11. The tracer wire should be taped to the riser and a 12" pigtail brought up next to the riser bracket. If additional protection is needed, the tracer wire may be brought up through a short section of 1/2" PE tubing taped to the riser.
12. The bottom of the riser bracket should be installed 2" above final grade.
13. The riser should typically be placed 8" from the foundation.
14. The tracer wire shall be attached to steel mains and the connection coated in accordance with [CORR 2.8 Appendix B.](#)

PE2708 - Medium Density PE Pipe - (Yellow) (G3213##)										
Item	Main Type	Stock No.	Description	Quantity						
				01	25	02	03	04	06	08
1	Steel	19 12 597	Tee, Service, 3/4" Weld Inlet, 1" CTS Outlet	1						
	PE	19 22 405	Tee, Service, 1-1/4" IPS X 1" CTS, Electrofusion PE4710		1					
		19 22 406	Tee, Service, 2" IPS X 1" CTS, Electrofusion, PE4710			1				
		19 22 408	Tee, Service, 3" IPS X 1" CTS, Electrofusion, PE4710				1			
		19 22 410	Tee, Service, 4" IPS X 1" CTS, Electrofusion, PE4710					1		
		19 22 411	Tee, Service, 6" IPS X 1" CTS, Electrofusion, PE4710						1	
		19 22 399	Tee, Service, 8" IPS X 1" CTS, Electrofusion, PE4710							1
2		19 22 506	Coupling, Pipe, 1" CTS, Electrofusion, PE4710	3	2	2	2	2	2	2
3		39 22 551	Valve, Excess Flow, 1" CTS, 0.101 Wall, Series 1100, PE4710	1	1	1	1	1	1	1
4		32 22 003	Pipe, PE2708, 1" CTS, 0.099 Wall	X	X	X	X	X	X	X
5		19 17 351	Riser, Service, 1" IPS Outlet X 1" CTS, Partial Flex, Anodeless, PE2708, SDR 11.5	1	1	1	1	1	1	1
6		39 01 084	Valve, Meter, Insulating, 1" IPS	1	1	1	1	1	1	1
7		18 66 369	Wire, Tracer, #12 AWG, Cu	X	X	X	X	X	X	X
8		17 54 842	Connector, Split Bolt, Copper, #16 to #10		1	1	1	1	1	1
9		49 62 001	Box Splice, Plastic		1	1	1	1	1	1

X - Number of feet required for specific installation.

PE 4710 - High Density PE Pipe - (Black) (G3253##)

UNCONTROLLED IF PRINTED

Item	Main Type	Stock No.	Description	Quantity			
				01	02	04	06
1	Steel	19 12 597	Tee, Service, 3/4" Weld Inlet, 1" CTS Outlet	1			
	PE	19 22 406	Tee, Service, 2" IPS X 1" CTS, Electrofusion Saddle & Coupling, PE4710		1		
		19 22 410	Tee, Service, 4" IPS X 1" CTS, Electrofusion Saddle & Coupling, PE4710			1	
		19 22 411	Tee, Service, 2" IPS X 1" CTS, Electrofusion Saddle & Coupling, PE4710				1
2		19 22 506	Coupling, Pipe, 1" CTS, Electrofusion, PE4710	3	2	2	2
3		39 22 551	Valve, Excess Flow, 1" CTS, 0.101 Wall, Series 1100, PE4710	1	1	1	1
4		32 22 019	Pipe, PE4710, 1" CTS, 0.101 Wall	X	X	X	X
5		19 17 139	Riser, Service, 1" IPS Outlet X 1" CTS, Partial Flex, Anodeless, PE4710, SDR 7.0	1	1	1	1
6		39 01 084	Valve, Meter, Insulating, 1" IPS	1	1	1	1
7		18 66 369	Wire, Tracer, #12 AWG, Cu	X	X	X	X
8		17 54 842	Connector, Split Bolt, Copper, #16 to #10		1	1	1
9		49 62 001	Box Splice, Plastic		1	1	1

X - Number of feet required for specific installation.

B-4. 1" PE Service Line, Rigid Riser

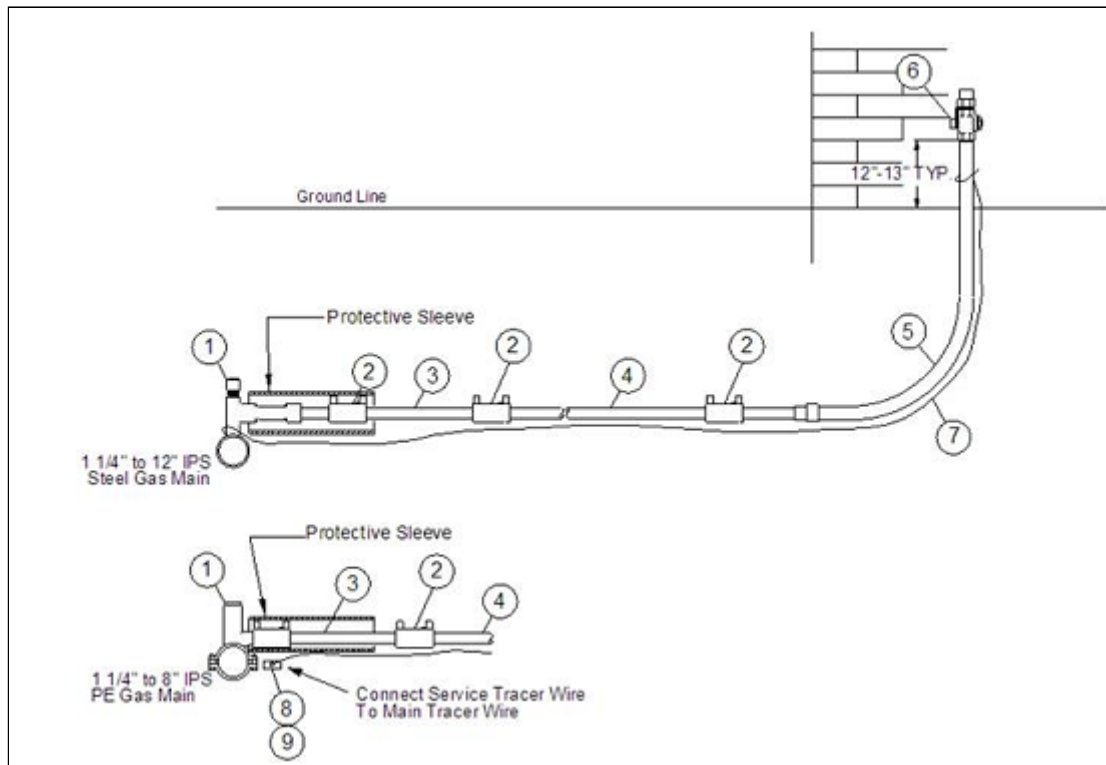

Installation

1. PE2708 service line shall be utilized on distribution systems with a MAOP between 0 and 60 psig.
2. PE4710 service line shall be utilized on 1-inch service lines with a MAOP between 61 and 125 psig. PE4710 can also be installed in systems with MAOP less than 61 psig.
3. PE4710 service line shall require a PE4710 riser that is SDR 7.0, Stock Number 19 72 140
4. PE4710 riser shall not be used on a PE4710 service.
5. Caution: Electrofusion coupling is the ONLY approved means of connecting PE4710 service line, wall thickness 0.101, equivalent to SDR 11.1, with the PE4710 riser, SDR 7. Butt fusion is not allowed when connecting two pipe sections with a wall thickness difference that exceeds one SDR value.
6. The EFV shall be installed in accordance with [SERV 2. 2](#).
7. The EFV can be butt fused to the service tee outlet and the PE 2708 or PE 4710 service line.
8. A protective sleeve, [POLY 3.1 Appendix B](#), shall be placed over the connection between the tee and the service pipe.
9. The tracer wire should be taped to the riser and a 12" pigtail brought up next to the riser bracket. If additional protection is needed, the tracer wire may be brought up through a short section of 1/2" PE tubing taped to the riser.
10. The riser should typically be placed 8" from the foundation.
11. The tracer wire shall be attached to steel mains and the connection coated in accordance with [CORR 2.8 Appendix B](#).
12. A riser bracket (62-54-019) or meter post (62-54-287) should be installed if the meter set assembly is not tied into the customer piping or a multiple meter header is install

PE2708 - Medium Density PE Pipe - (Yellow) (G3223##)										
Item	Main Type	Stock No.	Description	Quantity						
				01	25	02	03	04	06	08
1	Steel	19 12 597	Tee, Service, 3/4" Weld Inlet, 1" CTS Outlet	1						
	PE	19 22 405	Tee, Service, 1-1/4" IPS X 1" CTS, Electro-fusion PE4710		1					
		19 22 406	Tee, Service, 2" IPS X 1" CTS, Electro-fusion, PE4710			1				
		19 22 408	Tee, Service, 3" IPS X 1" CTS, Electro-fusion, PE4710				1			
		19 22 410	Tee, Service, 4" IPS X 1" CTS, Electro-fusion, PE4710					1		
		19 22 411	Tee, Service, 6" IPS X 1" CTS, Electro-fusion, PE4710						1	
		19 22 399	Tee, Service, 8" IPS X 1" CTS, Electro-fusion, PE4710							1
2		19 22 506	Coupling, Pipe, 1" CTS, Electrofusion, PE4710	3	2	2	2	2	2	2
3		39 22 551	Valve, Excess Flow, 1" CTS, 0.101 Wall, Series 1100, PE4710	1	1	1	1	1	1	1
4		32 22 003	Pipe, PE2708, 1" CTS, 0.099 Wall	X	X	X	X	X	X	X
5		19 17 044	Riser, Service, 1" IPS Outlet X 1" CTS, Rigid, Anodeless, PE2708, SDR 11.5	1	1	1	1	1	1	1
6		39 01 084	Valve, Meter, Insulating, 1" IPS	1	1	1	1	1	1	1
7		18 66 369	Wire, Tracer, #12 AWG, Cu	X	X	X	X	X	X	X
8		17 54 842	Connector, Split Bolt, Copper, #16 to #10		1	1	1	1	1	1
9		49 62 001	Box Splice, Plastic		1	1	1	1	1	1

X - Number of feet required for specific installation.

PE 4710 - High Density PE Pipe - (Black) (G3263##)									
Item	Main Type	Stock No.	Description	Quantity					
				01	02	04	06		

UNCONTROLLED IF PRINTED

1	Steel	19 12 597	Tee, Service, 3/4" Weld Inlet, 1" CTS Outlet	1			
	PE	19 22 406	Tee, Service, 2" IPS X 1" CTS, Electrofusion Saddle & Coupling, PE4710		1		
		19 22 410	Tee, Service, 4" IPS X 1" CTS, Electrofusion Saddle & Coupling, PE4710			1	
		19 22 411	Tee, Service, 2" IPS X 1" CTS, Electrofusion Saddle & Coupling, PE4710				1
2		19 22 506	Coupling, Pipe, 1" CTS, Electrofusion, PE4710	3	2	2	2
3		39 22 551	Valve, Excess Flow, 1" CTS, 0.101 Wall, Series 1100, PE4710	1	1	1	1
4		32 22 019	Pipe, PE4710, 1" CTS, 0.101 Wall	X	X	X	X
5		19 17 140	Riser, Service, 1" IPS Outlet X 1" CTS, Rigid, Anodeless, PE4710, SDR 7.0	1	1	1	1
6		39 01 084	Valve, Meter, Insulating, 1" IPS	1	1	1	1
7		18 66 369	Wire, Tracer, #12 AWG, Cu	X	X	X	X
8		17 54 842	Connector, Split Bolt, Copper, #16 to #10		1	1	1
9		49 62 001	Box Splice, Plastic		1	1	1

X - Number of feet required for specific installation.

B-5. 2" PE Service Line, Rigid Riser

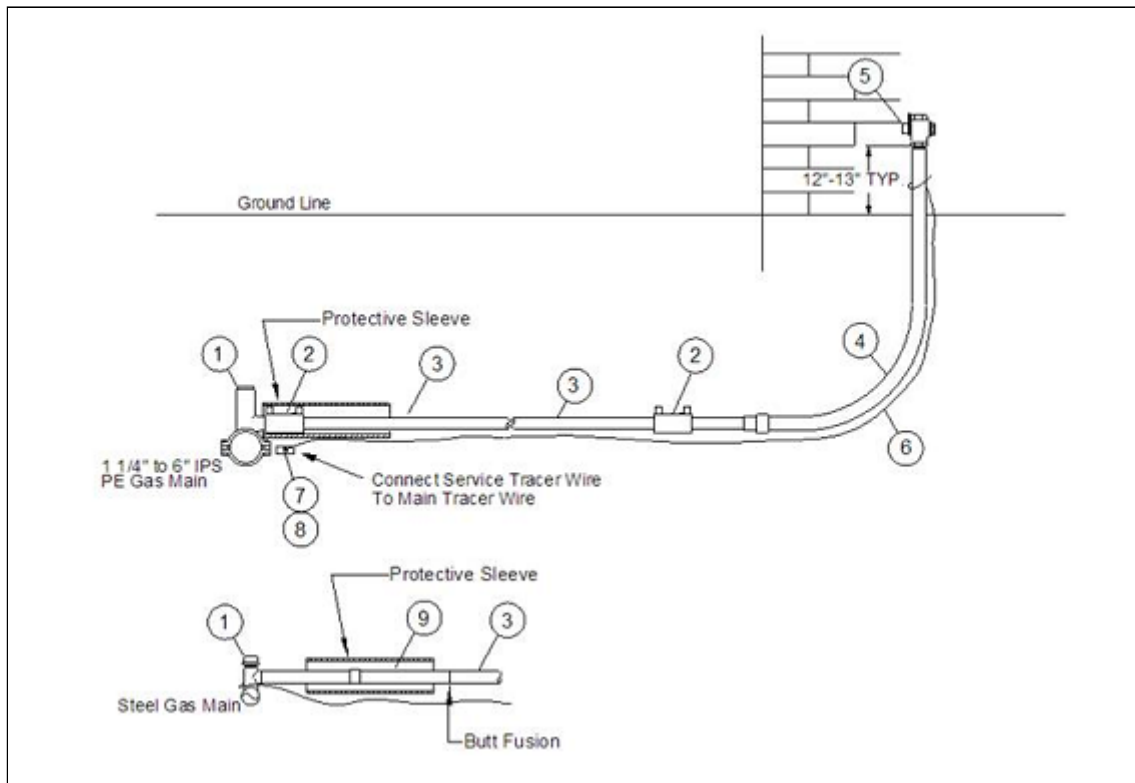

Installation

1. PE2708 service line shall be utilized on **2-inch service lines** with a MAOP between 0 and 60 psig.
2. PE4710 service line shall be utilized on **2-inch service lines** with a MAOP between 61 and 125 psig. **PE4710** can also be installed in systems with MAOP less than 61 psig.
3. PE4710 service line shall require a PE4710 riser that is SDR 7.0, Stock Number 19 72 154
4. PE2708 riser shall not be used on a PE4710 service line.
5. Caution: Electrofusion coupling is the **ONLY** approved means of connecting PE4710 service line, SDR 11, with the PE4710 riser, SDR 7. Butt fusion is not allowed when connecting two pipe sections with a wall thickness difference that exceeds one SDR value.
6. A protective sleeve, [POLY 3.1 Appendix B](#), is optional for 2 inch and larger service lines. If a protective sleeve is installed it, shall be placed over the connection between the tee and the service pipe.
7. The tracer wire should be taped to the riser and a 12" pigtail brought up next to the riser bracket. If additional protection is needed, the tracer wire may be brought up through a short section of 1/2" PE tubing taped to the iser.
8. The tracer wire shall be attached to steel mains and the connection coated in accordance with [CORR 2.8 Appendix B](#).
9. Notice: The manufacturer of the 2 inch IPS riser, 19 17 238, says the threaded end of the riser cannot be removed to allow for welding of any kind on the riser. There is insufficient space between transition area of the riser and the weld to avoid heat damage to the inserted PE pipe.
10. The EFV shall be installed in accordance with **SERV 2.2 Excess Flow Valves or Manual Shut-off Valves**.

PE2708 - Medium Density PE Pipe Service - (Yellow) OFF of PE Main - (G3313##)							
Item	Stock No.	Description	Quantity				
			02	03	04	06	08
1	19 22 412	Tee, Service, 2" IPS X 2" IPS, Electrofusion X Pipe, PE4710	1				
	19 22 413	Tee, Service, 3" IPS X 2" IPS, Electrofusion X Pipe, PE4710		1			
	19 22 414	Tee, Service, 4" IPS X 2" IPS, Electrofusion X Pipe, PE4710			1		
	19 22 415	Tee, Service, 6" IPS X 2" IPS, Electrofusion X Pipe, PE4710				1	
	19 17 342	Tee, Service, 8" IPS X 2" IPS, Electrofusion X Pipe, PE4710					1
2	19 22 278	Coupling, Pipe, 2" IPS, Electrofusion, PE4710	2	2	2	2	2
3	32 22 001	Pipe, PE2708, 2" CTS, 0.216 Wall	X	X	X	X	X
4	19 17 238	Riser, Service, 2" IPS Outlet X 2" PE Inlet, Anodeless, PE2708, SDR 11.0	1	1	1	1	1
5	39 22 111	Valve, Meter, Insulating, 2" IPS	1	1	1	1	1
6	18 66 369	Wire, Tracer, #12 AWG, Cu	X	X	X	X	X
7	17 54 842	Connector, Split Bolt, Copper, #16 to #10	1	1	1	1	1
8	49 62 001	Box Splice, Plastic	1	1	1	1	1

X - Number of feet required for specific installation.

PE2708 - Medium Density PE Pipe - (Yellow) OFF of STEEL MAIN						
Item	Stock No.	Description	Quantity			
			12	22	32	
1	19 22 286	Tee, Steel, Service Tee, Mueller, 2"	1			
	19 12 230	Tee, Steel, Valve, 2"		1		
	19 08 417	Tee, 3-Way, Class 150, TDW, 2"			1	
2	19 22 278	Coupling, Pipe, 2" IPS, Electrofusion, PE4710	1	1	1	
3	32 22 001	Pipe, PE2708, 2" CTS, 0.216 Wall	X	X	X	
4	19 17 238	Riser, Service, 2" IPS Outlet X 2" PE Inlet, Anodeless, PE2708, SDR 11.0	1	1	1	
5	39 22 111	Valve, Meter, Insulating, 2" IPS	1	1	1	
6	18 66 369	Wire, Tracer, #12 AWG, Cu	X	X	X	
7	17 54 842	Connector, Split Bolt, Copper, #16 to #10				
8	49 62 001	Box Splice, Plastic				
9	19 17 129	Fitting, Transition, PE2708 to Steel, 2"	1	1	1	

X - Number of feet required for specific installation.

UNCONTROLLED IF PRINTED

PE4710 - High Density PE Pipe Service - (Black) OFF of PE Main							
Item	Stock No.	Description	Quantity				
			02	03	04	06	08
1	19 22 412	Tee, Service, 2" IPS X 2" IPS, Electrofusion X Pipe, PE4710	1				
	19 22 413	Tee, Service, 3" IPS X 2" IPS, Electrofusion X Pipe, PE4710		1			
	19 22 414	Tee, Service, 4" IPS X 2" IPS, Electrofusion X Pipe, PE4710			1		
	19 22 415	Tee, Service, 6" IPS X 2" IPS, Electrofusion X Pipe, PE4710				1	
	19 17 342	Tee, Service, 8" IPS X 2" IPS, Electrofusion X Pipe, PE4710					1
2	19 22 278	Coupling, Pipe, 2" IPS, Electrofusion, PE4710	2	2	2	2	2
3	32 22 031	Pipe, PE4710, 2" IPS, 0.216 Wall	X	X	X	X	X
4	19 72 154	Riser, Service, 2" IPS X 2" IPS, Bent, w/Pigtail, Anodeless, PE4710, SDR 7.0	1	1	1	1	1
5	39 22 111	Valve, Meter, Insulating, 2" IPS	1	1	1	1	1
6	18 66 369	Wire, Tracer, #12 AWG, Cu	X	X	X	X	X
7	17 54 842	Connector, Split Bolt, Copper, #16 to #10	1	1	1	1	1
8	49 62 001	Box Splice, Plastic	1	1	1	1	1

X - Number of feet required for specific installation.

PE4710 - High Density PE Pipe - (Black) OFF of STEEL MAIN					
Item	Stock No.	Description	Quantity		
			12	22	32
1	19 22 286	Tee, Steel, Service Tee, Mueller, 2"	1		
	19 12 230	Tee, Steel, Valve, 2"		1	
	19 08 417	Tee, 3-Way, Class 150, TDW, 2"			1
2	19 22 278	Coupling, Pipe, 2" IPS, Electrofusion, PE4710	1	1	1
3	32 22 031	Pipe, PE4710, 2" IPS, 0.216 Wall	X	X	X
4	19 72 154	Riser, Service, 2" IPS X 2" IPS, Bent, w/Pigtail, Anodeless, PE4710, SDR 7.0	1	1	1
5	39 22 111	Valve, Meter, Insulating, 2" IPS	1	1	1
6	18 66 369	Wire, Tracer, #12 AWG, Cu	X	X	X
7	17 54 842	Connector, Split Bolt, Copper, #16 to #10			
8	49 62 001	Box Splice, Plastic			
9	19 22 106	Fitting, Transition, PE4710 to Steel, 2"	1	1	1

UNCONTROLLED IF PRINTED

X - Number of feet required for specific installation.

1.0 Purpose

This document provides requirements for sizing a gas service line.

2.0 Scope

This document addresses the following:

[3.0 Target Audience](#)

[4.0 Determining Service Line Capacity](#)

[5.0 Service Line sizing example](#)

Appendices

[Appendix A - Gas Customer Load Information form](#)

[Appendix B - Estimated Demand of Gas Appliances](#)

[Appendix C - Pressure System Classification/Allowed Pressure Drop: Services](#)

[Appendix D - Demand Diversity Factor for Appliance](#)

[Appendix E - Service Line Capacity Tables](#)

3.0 Target Audience

- Gas Engineering
- Gas Distribution Design Specialist
- Field Engineering Representative
- Gas Field Personnel
- Gas Supervisors

4.0 Determining Service Line Capacity

4.1 To determine service line size, the following factors must be determined:

4.1.1 Customer load demand

1. Refer to data from the "Gas Customer Load Information Form". A copy of a blank form is in [Appendix A](#).
2. If the Gas Customer Load Information is not available, use the appliance demand table in [Appendix B](#) to estimate the demand.

4.1.2 System allowed pressure drop for services

1. Refer to Table "Pressure System Classification/Allowed Pressure Drop for Services" in [Appendix C](#).

4.1.3 Demand Diversity Factor for Appliances is used to estimate total design loads for multiple residence housing units.

1. Refer to "Diversity Factor for Appliances" in [Appendix D](#).

4.1.4 Service line length; from gas main to meter location.

4.2 Service line demand load Calculation

UNCONTROLLED IF PRINTED

4.2.1 Appliance Design Load = Estimated Appliance Demand ([Section 4.1.1](#)) x Demand Diversity Factor ([Section 4.1.3](#)) x # of Customers.

4.2.2 Total Design Load for a housing unit is the sum all of the Appliance Design Loads.

4.3 Service Line Size

4.3.1 Service line size is determined by using the capacity tables in [Appendix E](#) and the following:

1. Service Line inlet pressure
2. System allowed pressure drop ([Section 4.1.2](#))
3. Service Line Length ([Section 4.1.4](#))
4. Service line load ([Section 4.2](#))

5.0 Service Line sizing Example

5.1 The following is an example of service line sizing using the charts in Appendices [B](#), [C](#), [D](#), and [E](#).

5.1.1 Known information (example):

1. 100 customers on the service (an apartment building)
2. 1 cooking range per customer
3. 1- 30 gallon hot water heater per customer
4. Space Heater/5 radiant heaters per customer
5. Distance from main to meters: 100 ft. of gas service
6. Service line inlet pressure: 50 psig

5.1.2 Table information (example)

1. Cooking range demand from [Appendix B](#): 60 CFH
2. Space heater demand from [Appendix B](#): 11 CFH
3. 30 gallon hot water heater demand from [Appendix B](#): 33 CFH
4. Demand diversity factors from [Appendix D](#):
 - 4 a. Cooking Range: .20
 - 4 b. Space Heating: .76
 - 4 c. Water Heater: .33
5. Allowed pressure drop for a 50 psig main from [Appendix C](#): 5 psig

5.1.3 Calculated demand:

1. Cooking Range demand: 100 customers x .20 diversity x 60 CFH/customer = 1200 CFH
2. Space heating demand: 100 customers x .76 diversity x 11 CFH = 836 CFH
3. Water heating demand: 100 Customers x .33 diversity x 33 CFH = 1089 CFH
4. Total demand = 1200 CFH + 836 CFH + 1089 CFH = 3125 CFH

5.1.4 Required service line size from tables in [Appendix E](#):

1. Comparing 100 ft. length, 50 psig, and a demand of 3125 CFH in each table in Appendix E results in the following:

½" CTS PE	998 CFH	Under capacity
1" CTS PE	5780 CFH	Approximately Correct size
1 ¼" CTS PE	14827 CFH	Over capacity
2" IPS PE	42308 CFH	Over capacity
¾" Steel	3794 CFH	Approximately Correct size
1 ¼" Steel	48244 CFH	Over capacity
2" Steel	48244 CFH	Over capacity

2. From the above information either 1" CTS PE or ¾" Steel would be the appropriate service line sizes.

End of Instructions.

Operator Qualification (OQ) Required?

NO.

Appendices

[Appendix A - Gas Customer Load Information form](#)

[Appendix B - Estimated Demand of Gas Appliances](#)

[Appendix C - Pressure System Classification/Allowed Pressure Drop: Services](#)

[Appendix D - Demand Diversity Factor for Appliance](#)

[Appendix E - Service Line Capacity Tables](#)

Attachments

NONE.

Compliance Requirements

NONE.

Reference Documents

NONE.

Document Rescission

SERV 2.1 Service Line Installation: Service Line Capacity, October 1, 2020.

Revision Notes

Location of Changes	Summary of Changes
---------------------	--------------------

Appendix E-6 – 1-1/4" Steel Service Line	Corrected the Capacity Table.
--	-------------------------------

Appendix A - Gas Customer Load Information



Gas Customer Load Information

Customer Name: _____

Service Address: _____

Contact Name: _____

Phone Number: _____ Ext. _____

Email Address: _____

Space Heating:

# Units	Description	BTU (each)	Total BTU
Total BTU:			_____

Water Heating:

# Units	Description	BTU (each)	Total BTU
Total BTU:			_____

Process Heating / other:

# Units	Description	BTU (each)	Total BTU
Total BTU:			_____

Total Gas Load (BTU): _____

Total Gas Load (CFH):* _____

* @1,000 btu / cubic foot

Delivery Pressure:

_____ 5" - 7" Water Column

_____ 2 psig

_____ 5 psig

Notes: _____

Appendix B - Estimated Demand of Gas Appliances

Category	Appliance Description	CFH
Air Conditioning Units	3 ton, cooling	72
	3 ton, heating cycle	120
	5 ton, cooling	112
	5 ton, heating cycle	120-180

UNCONTROLLED IF PRINTED

Boiler	Steam processing, per hp	45-50
Cooking Equipment, Domestic	Built-in standard top burner, per burner	9
	Built-in giant top burner, per burner	12
	Incinerator	35
	Range	60-75
	Oven	12-22
	Broiler	12-22
Cooking Equipment, Restaurant	Coffee maker: 1 gallon	11
	Coffee maker: 2 - 4 gallon	17
	Coffee maker: 5 - 8 gallon	23
	Coffee maker: 8 - 12 gallon	39
	Commercial Range: 4 top burners, 2 oven burners	165
	Commercial Range: 6 top burners, 2 - 4 oven burners	264
	Waffle iron	13
	Cake griddle	17
	Steam table, per burner	17
	Toaster: 6 slice	22
	Toaster: 9 slice	35
	Toaster: 20 slice	53
	Hot plate	9
	Refrigerator	4
Miscellaneous	Clothes dryer	18-20
	Dishwasher (10 minute max. demand)	18.5
	Gas engines, per hp	8-11
	Gas lights, per mantle	3-5
	Gas steam radiators, per section	2
Space Heating	Gas logs: 18" set	75
	Gas logs: 24" set	90
	Radiant: 5 radiants	11
	Radiant: 10 radiants	22
	Warm air, per room	20
	Steam or hot water, per room	30
	Wall heaters, per tube	12
Water Heaters	Storage tank: 30 gallon	33
	Storage tank: 40 - 50 gallon	50
	Instantaneous coil: 2.5 gallon/minute	110
	Instantaneous coil: 3 gallon/minute	138
	Instantaneous coil: 4 gallon/minute	176
	Instantaneous coil: 6 gallon/minute	264
	Instantaneous coil: 8 gallon/minute	352

UNCONTROLLED IF PRINTED

Appendix C - Pressure System Classification/Allowed Pressure Drop - Services

Pressure System MAOP	Recommended Pressure Drop
≤ 14"	1"
15" to 2 psig	¼ psig
3 psig to 10 psig	1 psig
11 psig to 25 psig	2 psig
26 psig to 50 psig	5 psig
> 50 psig	10% of system operating pressure

Appendix D - Demand Diversity Factor for Appliance

No. of Customers	Cooking Ranges	Water Heaters	Space Heating
1	1.00	1.00	1.00
5	0.70	0.50	0.92
10	0.57	0.43	0.88
25	0.40	0.37	0.84
50	0.29	0.34	0.80
75	0.24	0.34	0.78
100	0.20	0.33	0.76

Appendix E - Service Line Capacity Tables

E-1. ½" CTS PE Service Line

Service Line Length (feet)	Service Inlet Pressure											
	14" W.C.	2 psig	5 psig	10 psig	15 psig	20 psig	25 psig	30 psig	40 psig	50 psig	60 psig	90 psig
	Allowed Pressure Drop											
	1" W.C.	1/4 psig	1 psig	1 psig	2 psig	2 psig	2 psig	5 psig	5 psig	5 psig	6 psig	9 psig
20	51	174	409	466	753	824	891	1,556	1,752	1,932	2,315	3,495
40	39	135	318	362	586	641	693	1,210	1,363	1,503	1,801	2,719
60	33	114	268	305	493	540	583	1,019	1,147	1,265	1,516	2,288
80	29	100	235	267	433	473	512	893	1,006	1,110	1,329	2,007
100	26	90	211	240	389	426	460	803	905	998	1,195	1,805
120	24	82	193	220	356	389	421	735	828	913	1,093	1,651
140	22	76	179	204	330	361	390	681	767	845	1,013	1,529
160	20	71	167	190	308	337	364	636	717	790	947	1,429
180	19	67	157	179	290	317	343	599	675	744	891	1,346
200	18	64	149	170	275	301	325	567	639	705	844	1,275
250	16	57	133	151	245	268	289	505	569	628	752	1,135
300	14	51	121	137	222	243	263	459	517	570	683	1,031
350	13	47	111	127	205	224	242	423	476	525	629	950
400	12	44	103	118	191	209	225	394	443	489	586	885

UNCONTROLLED IF PRINTED

450	12	41	97	111	179	196	212	370	416	459	550	830
500	11	39	92	105	169	185	200	349	393	434	520	785

E-2. 1" CTS PE Service Line

Service Line Length (feet)	Service Inlet Pressure											
	14" W.C.	2 psig	5 psig	10 psig	15 psig	20 psig	25 psig	30 psig	40 psig	50 psig	60 psig	90 psig
	Allowed Pressure Drop											
	1" W.C.	1/4 psig	1 psig	1 psig	2 psig	2 psig	2 psig	5 psig	5 psig	5 psig	6 psig	9 psig
20	227	753	1,768	2,014	3,258	3,565	3,852	6,727	7,577	8,356	10,011	15,113
40	201	670	1,572	1,791	2,897	3,170	3,425	5,982	6,738	7,431	8,902	13,438
60	182	608	1,427	1,625	2,629	2,877	3,109	5,430	6,116	6,745	8,080	12,198
80	167	560	1,314	1,497	2,421	2,650	2,863	5,000	5,632	6,211	7,440	11,232
100	155	521	1,223	1,393	2,254	2,466	2,665	4,654	5,241	5,780	6,925	10,454
120	145	489	1,147	1,307	2,115	2,314	2,501	4,367	4,919	5,424	6,498	9,810
140	137	462	1,084	1,235	1,998	2,186	2,362	4,125	4,646	5,124	6,138	9,266
160	130	438	1,029	1,173	1,897	2,076	2,243	3,917	4,412	4,865	5,829	8,799
180	123	418	982	1,118	1,809	1,980	2,139	3,736	4,208	4,641	5,559	8,393
200	118	400	940	1,071	1,732	1,895	2,048	3,577	4,028	4,443	5,322	8,035
250	107	364	854	973	1,573	1,722	1,861	3,249	3,659	4,036	4,835	7,299
300	98	335	787	896	1,450	1,586	1,714	2,994	3,372	3,719	4,455	6,725
350	91	312	732	835	1,350	1,477	1,596	2,788	3,140	3,463	4,148	6,262
400	85	293	688	783	1,267	1,387	1,498	2,617	2,947	3,251	3,894	5,879
450	80	277	650	740	1,197	1,310	1,416	2,473	2,785	3,071	3,679	5,554
500	76	263	617	703	1,137	1,244	1,345	2,349	2,645	2,917	3,495	5,276

Notes:

1. Capacity of service lines in CFH for actual length of service. Equivalent footages for fittings have been added.
2. Service Inlet Pressure should equal lowest expected pressure on main that is likely to occur at the service tap.

E-3. 1 1/4" IPS PE Service Line

Service Line Length (feet)	Service Inlet Pressure											
	14" W.C.	2 psig	5 psig	10 psig	15 psig	20 psig	25 psig	30 psig	40 psig	50 psig	60 psig	90 psig
	Allowed Pressure Drop											
	1" W.C.	1/4 psig	1 psig	1 psig	2 psig	2 psig	2 psig	5 psig	5 psig	5 psig	6 psig	9 psig
20	584	1,903	4,466	5,088	8,230	9,006	9,732	16,996	19,143	21,112	25,291	38,181
40	521	1,702	3,995	4,551	7,362	8,056	8,706	15,203	17,123	18,884	22,623	34,153
60	473	1,551	3,641	4,148	6,710	7,342	7,934	13,856	15,605	17,210	20,617	31,125
80	436	1,432	3,362	3,831	6,197	6,781	7,328	12,797	14,413	15,895	19,042	28,747

UNCONTROLLED IF PRINTED

100	405	1,336	3,137	3,573	5,780	6,325	6,835	11,937	13,444	14,827	17,763	26,815
120	380	1,256	2,949	3,359	5,434	5,946	6,426	11,222	12,639	13,939	16,698	25,208
140	359	1,188	2,789	3,178	5,140	5,625	6,078	10,615	11,955	13,185	15,795	23,845
160	341	1,130	2,652	3,021	4,887	5,348	5,779	10,092	11,366	12,535	15,016	22,670
180	325	1,078	2,532	2,884	4,666	5,105	5,517	9,635	10,851	11,967	14,337	21,643
200	311	1,033	2,426	2,763	4,470	4,892	5,286	9,231	10,397	11,467	13,737	20,738
250	282	940	2,207	2,515	4,068	4,451	4,810	8,400	9,461	10,434	12,499	18,870
300	259	867	2,036	2,320	3,752	4,106	4,437	7,749	8,727	9,625	11,531	17,407
350	241	808	1,898	2,162	3,497	3,827	4,135	7,222	8,134	8,971	10,746	16,224
400	226	759	1,783	2,031	3,285	3,595	3,885	6,785	7,641	8,427	10,095	15,241
450	213	718	1,685	1,920	3,106	3,399	3,673	6,414	7,224	7,967	9,544	14,408
500	202	682	1,601	1,825	2,951	3,230	3,490	6,095	6,865	7,571	9,069	13,692

Notes:

1. Capacity of service lines in CFH for actual length of service. Equivalent footages for fittings have been added.
2. Service Inlet Pressure should equal lowest expected pressure on main that is likely to occur at the service tap.

E-4. 2" IPS PE Service Line

Service Line Length (feet)	Service Inlet Pressure											
	14" w.c.	2 psig	5 psig	10 psig	15 psig	20 psig	25 psig	30 psig	40 psig	50 psig	60 psig	90 psig
	Allowed Pressure Drop											
	1" W.C.	1/4 psig	1 psig	1 psig	2 psig	2 psig	2 psig	5 psig	5 psig	5 psig	6 psig	9 psig
20	1,764	5,604	13,154	14,987	24,243	26,528	28,666	50,063	56,385	62,184	74,494	112,461
40	1,551	4,950	11,621	13,239	21,416	23,435	25,324	44,226	49,810	54,933	65,808	99,348
60	1,397	4,473	10,501	11,964	19,353	21,178	22,884	39,965	45,012	49,641	59,468	89,777
80	1,278	4,106	9,639	10,982	17,764	19,439	21,006	36,685	41,317	45,566	54,587	82,408
100	1,184	3,813	8,950	10,197	16,494	18,049	19,504	34,062	38,363	42,308	50,684	76,516
120	1,106	3,571	8,383	9,551	15,449	16,906	18,268	31,904	35,933	39,628	47,473	71,669
140	1,041	3,368	7,906	9,008	14,571	15,945	17,230	30,090	33,890	37,375	44,774	67,594
160	986	3,194	7,499	8,543	13,819	15,122	16,341	28,538	32,142	35,447	42,465	64,108
180	938	3,044	7,145	8,140	13,167	14,409	15,570	27,191	30,625	33,775	40,461	61,082
200	896	2,911	6,834	7,786	12,594	13,782	14,893	26,008	29,293	32,305	38,701	58,425
250	809	2,640	6,198	7,061	11,422	12,499	13,506	23,587	26,565	29,298	35,098	52,986
300	743	2,430	5,704	6,498	10,511	11,502	12,429	21,707	24,448	26,962	32,300	48,762
350	689	2,260	5,306	6,045	9,779	10,701	11,563	20,193	22,743	25,083	30,048	45,362
400	645	2,120	4,977	5,671	9,173	10,038	10,847	18,943	21,335	23,529	28,187	42,553
450	608	2,002	4,700	5,355	8,662	9,479	10,242	17,887	20,146	22,218	26,617	40,182
500	576	1,901	4,462	5,084	8,223	8,999	9,724	16,982	19,126	21,093	25,269	38,147
550	548	1,813	4,255	4,848	7,842	8,581	9,273	16,194	18,238	20,114	24,096	36,377
600	524	1,735	4,073	4,640	7,506	8,214	8,875	15,500	17,457	19,253	23,064	34,819

UNCONTROLLED IF PRINTED

650	503	1,666	3,911	4,456	7,207	7,887	8,523	14,884	16,763	18,487	22,147	33,435
700	483	1,604	3,766	4,290	6,940	7,594	8,206	14,332	16,141	17,801	21,325	32,194
750	466	1,548	3,635	4,141	6,699	7,330	7,921	13,833	15,580	17,182	20,584	31,075
800	450	1,498	3,516	4,005	6,479	7,090	7,662	13,380	15,070	16,620	19,910	30,057
850	436	1,451	3,407	3,882	6,279	6,871	7,425	12,967	14,604	16,106	19,295	29,128
900	423	1,409	3,307	3,768	6,095	6,670	7,207	12,587	14,176	15,635	18,730	28,275
950	410	1,370	3,215	3,663	5,926	6,484	7,007	12,237	13,782	15,200	18,209	27,489
1000	399	1,333	3,130	3,566	5,769	6,313	6,821	11,913	13,417	14,797	17,726	26,761

Notes:

1. Capacity of service lines in CFH for actual length of service. Equivalent footages for fittings have been added.
2. Service Inlet Pressure should equal lowest expected pressure on main that is likely to occur at the service tap

E-5. 3/4" Steel Service Line

Service Line Length (feet)	Service Inlet Pressure											
	14" W.C.	2 psig	5 psig	10 psig	15 psig	20 psig	25 psig	30 psig	40 psig	50 psig	60 psig	90 psig
	Allowed Pressure Drop											
	1" W.C.	1/4 psig	1 psig	1 psig	2 psig	2 psig	2 psig	5 psig	5 psig	5 psig	6 psig	9 psig
20	135	454	1,066	1,215	1,965	2,150	2,323	4,057	4,570	5,040	6,037	9,115
40	123	417	979	1,115	1,804	1,974	2,133	3,724	4,195	4,626	5,542	8,366
60	114	387	909	1,035	1,675	1,832	1,980	3,458	3,895	4,295	5,146	7,768
80	107	363	851	970	1,568	1,716	1,855	3,239	3,648	4,023	4,820	7,276
100	101	342	803	914	1,479	1,619	1,749	3,055	3,441	3,794	4,546	6,862
120	95	324	761	867	1,403	1,535	1,659	2,897	3,263	3,599	4,311	6,508
140	91	309	725	826	1,337	1,463	1,581	2,761	3,109	3,429	4,108	6,201
160	86	296	694	790	1,279	1,399	1,512	2,640	2,974	3,280	3,929	5,932
180	83	284	666	759	1,227	1,343	1,451	2,534	2,854	3,147	3,771	5,692
200	80	273	641	730	1,181	1,292	1,396	2,439	2,747	3,029	3,629	5,478
250	73	251	588	670	1,084	1,186	1,282	2,239	2,521	2,780	3,331	5,029
300	68	233	546	622	1,006	1,101	1,190	2,078	2,341	2,582	3,093	4,669
350	63	218	512	583	943	1,032	1,115	1,947	2,193	2,418	2,897	4,373
400	59	206	482	550	889	973	1,051	1,836	2,068	2,281	2,732	4,125
450	56	195	458	521	843	923	997	1,741	1,961	2,163	2,591	3,912
500	53	186	436	497	803	879	950	1,659	1,869	2,061	2,469	3,727

Notes:

1. Capacity of service lines in CFH for actual length of service. Equivalent footages for fittings have been added.
2. Service Inlet Pressure should equal lowest expected pressure on main that is likely to occur at the service tap

E-6. 1 ¼" Steel Service Line

Service Line Length (feet)	Service Inlet Pressure											
	14" w.c.	2 psig	5 psig	10 psig	15 psig	20 psig	25 psig	30 psig	40 psig	50 psig	60 psig	90 psig
	Allowed Pressure Drop											
	1" W.C.	1/4 psig	1 psig	1 psig	2 psig	2 psig	2 psig	5 psig	5 psig	5 psig	6 psig	9 psig
20	694	2,250	5,282	6,018	9,735	10,653	11,511	20,103	22,642	24,970	29,913	45,159
40	611	1,988	4,666	5,316	8,600	9,411	10,169	17,759	20,002	22,059	26,426	39,894
60	550	1,796	4,217	4,804	7,771	8,504	9,189	16,048	18,075	19,934	23,880	36,050
80	503	1,649	3,871	4,410	7,133	7,806	8,435	14,731	16,591	18,297	21,920	33,091
100	466	1,531	3,594	4,094	6,623	7,248	7,832	13,678	15,405	16,989	20,352	30,725
120	436	1,434	3,366	3,835	6,204	6,789	7,336	12,811	14,429	15,913	19,063	28,779
140	410	1,352	3,175	3,617	5,851	6,403	6,919	12,083	13,609	15,008	17,979	27,143
160	388	1,283	3,011	3,430	5,549	6,072	6,562	11,460	12,907	14,234	17,052	25,743
180	369	1,222	2,869	3,269	5,287	5,786	6,252	10,919	12,298	13,562	16,247	24,528
200	353	1,169	2,744	3,126	5,057	5,534	5,980	10,444	11,763	12,972	15,540	23,461
250	319	1,060	2,489	2,835	4,587	5,019	5,423	9,471	10,667	11,765	14,094	21,277
300	292	976	2,290	2,609	4,221	4,619	4,991	8,716	9,817	10,827	12,970	19,580
350	271	908	2,131	2,427	3,927	4,297	4,643	8,109	9,133	10,072	12,066	18,216
400	254	851	1,999	2,277	3,683	4,031	4,356	7,607	8,567	9,448	11,319	17,087
450	239	804	1,887	2,150	3,478	3,806	4,113	7,183	8,090	8,922	10,688	16,135
500	227	763	1,792	2,041	3,302	3,613	3,905	6,819	7,680	8,470	10,147	15,318

Notes:

1. Capacity of service lines in CFH for actual length of service. Equivalent footages for fittings have been added.
2. Service Inlet Pressure should equal lowest expected pressure on main that is likely to occur at the service tap

E-7. 2" Steel Service Line

Service Line Length (feet)	Service Inlet Pressure											
	14" w.c.	2 psig	5 psig	10 psig	15 psig	20 psig	25 psig	30 psig	40 psig	50 psig	60 psig	90 psig
	Allowed Pressure Drop											
	1" W.C.	1/4 psig	1 psig	1 psig	2 psig	2 psig	2 psig	5 psig	5 psig	5 psig	6 psig	9 psig

UNCONTROLLED IF PRINTED

20	1,951	6,190	14,531	16,555	26,780	29,305	31,667	55,303	62,286	68,692	82,291	124,231
40	1,738	5,537	12,998	14,809	23,955	26,213	28,326	49,468	55,715	61,445	73,609	111,125
60	1,579	5,046	11,846	13,496	21,831	23,890	25,815	45,083	50,776	55,999	67,084	101,275
80	1,454	4,661	10,941	12,464	20,163	22,064	23,842	41,638	46,896	51,719	61,957	93,535
100	1,353	4,348	10,206	11,627	18,808	20,582	22,240	38,841	43,745	48,244	57,795	87,251
120	1,269	4,087	9,594	10,930	17,681	19,348	20,908	36,513	41,124	45,353	54,332	82,022
140	1,198	3,866	9,075	10,339	16,725	18,302	19,777	34,538	38,899	42,900	51,393	77,586
160	1,137	3,675	8,628	9,830	15,901	17,400	18,802	32,836	36,982	40,786	48,860	73,762
180	1,084	3,509	8,237	9,385	15,181	16,612	17,951	31,349	35,308	38,939	46,648	70,423
200	1,037	3,362	7,892	8,992	14,545	15,917	17,199	30,037	33,830	37,309	44,695	67,475
250	941	3,059	7,181	8,182	13,235	14,483	15,650	27,331	30,783	33,949	40,669	61,397
300	865	2,822	6,625	7,548	12,209	13,361	14,437	25,213	28,397	31,318	37,518	56,639
350	805	2,630	6,174	7,035	11,379	12,452	13,456	23,499	26,466	29,188	34,966	52,788
400	754	2,471	5,800	6,608	10,690	11,698	12,640	22,075	24,863	27,420	32,848	49,590
450	712	2,336	5,484	6,247	10,106	11,059	11,950	20,869	23,505	25,922	31,054	46,881
500	675	2,220	5,211	5,937	9,603	10,509	11,356	19,832	22,336	24,633	29,510	44,550
550	643	2,119	4,973	5,666	9,165	10,029	10,837	18,926	21,316	23,509	28,163	42,516
600	615	2,029	4,763	5,427	8,779	9,606	10,380	18,128	20,417	22,517	26,975	40,723
650	590	1,950	4,577	5,214	8,434	9,230	9,973	17,418	19,617	21,635	25,918	39,127
700	568	1,878	4,409	5,023	8,126	8,892	9,608	16,780	18,899	20,842	24,969	37,694
750	548	1,814	4,258	4,851	7,846	8,586	9,278	16,203	18,250	20,127	24,111	36,399
800	529	1,755	4,120	4,694	7,593	8,308	8,978	15,679	17,659	19,475	23,331	35,222
850	513	1,701	3,994	4,550	7,361	8,054	8,704	15,200	17,119	18,880	22,618	34,145
900	497	1,652	3,878	4,418	7,147	7,821	8,451	14,760	16,623	18,333	21,962	33,156
950	483	1,607	3,771	4,297	6,950	7,606	8,219	14,353	16,166	17,828	21,357	32,243
1000	470	1,564	3,672	4,184	6,768	7,406	8,003	13,976	15,741	17,360	20,797	31,397

Notes:

1. Capacity of service lines in CFH for actual length of service. Equivalent footages for fittings have been added.
2. Service Inlet Pressure should equal lowest expected pressure on main that is likely to occur at the service tap

SERVICE LINE INSTALLATION

April 1, 2023

SERV 2.2 Excess Flow Valve or Manual Shut-off Valve

1.0 Purpose

This document provides the requirements for the installation of Excess Flow Valves (EFV) and manual service line shut-off valves on residential and commercial services. This document meets the requirements of 49 CFR §§ 192.381, 192.383, 192.385.

2.0 Scope

This document addresses the following:

[3.0 Target Audience](#)[4.0 Requirement for EFV Installation](#)[5.0 EFV Installation and Location](#)[6.0 EFV Sizing](#)[7.0 Requirements for Manual Service Line Shut-off Valve Installation](#)[8.0 Manual Service Line Shut-Off Valve Installation](#)[9.0 Inspection and Maintenance of Manual Shut-Off Valve](#)[10.0 EFV and Manual Shut-Off Valve Identification](#)

Appendices

[Appendix A - EFV Locations](#)[Appendix B - EFV Sizing Tables](#)

3.0 Target Audience

- Gas Engineering
- Gas Distribution Design Specialist
- Gas Field personnel
- Gas Construction personnel
- Gas Supervisors
- Gas Construction Services personnel

4.0 Requirement for EFV Installation (49 CFR §192.383)

4.1 Single Family Residence (SFR) services installed after April 14, 2017

4.1.1 EFV's are required on all new or replaced SFR services prior to activation. See [Appendix A-1](#).

4.1.2 EFV's are required on all new or replaced branch services to SFR's prior to activation.

1. If both services are installed at the same time then the EFV may be installed either on the primary service line, see [Appendix A-2](#), or on the primary service line close to the main and another EFV installed on the branch service line, see [Appendix A-3](#).
2. If a new installed branch service is installed off of an existing service line that does not have an EFV, then an EFV shall be installed on the branch service line. See [Appendix A-4](#).

UNCONTROLLED IF PRINTED

- 4.2 Multi-family residence service installed or replaced after April 14, 2017:
 - 4.2.1 EFV's are required, when available and approved by AIC, prior to activation.
 - 4.2.2 If EFV is not available and approved by AIC, refer to [Section 7.0](#) for manual shut-off valve requirements.
- 4.3 Single small commercial service installed or replaced after April 14, 2017:
 - 4.3.1 EFV's are required, when available and approved by AIC, prior to activation.
 - 4.3.2 If EFV is not available and approved by AIC, refer to [Section 7.0](#) for manual shut-off valve requirements.
 - 4.3.3 For branch service, an EFV shall be on each service line to a small commercial customer.
- 4.4 Residential and commercial farm taps
 - 4.4.1 Refer to [4.1](#) and [4.3](#) above for EFV requirements on the outlet side of the farm tap.
- 4.5 Schools, hospitals or nursing homes
 - 4.5.1 Each single service line one (1) inch and larger shall have a properly sized EFV installed, if it is available and approved by AIC.
 - 4.5.2 A manual service line shut-off valve shall be installed.
- 4.6 Replaced service line includes:
 - 4.6.1 Replacement of service tee or fitting that connects the service line to the main.
 - 4.6.2 Replacement of the service line from the service tee or fitting to the service riser.
 - 4.6.3 Replacement of a section of service line near the main where an EFV is typically installed
- 4.7 Exceptions to requirement for EFV
 - 4.7.1 Service line does not operate at a pressure of 10 psig or greater throughout the year.
 - 4.7.2 Gas mains that have experienced contaminants in the gas stream that could interfere with the operation of this EFV or cause loss of service to the customer.
 - 4.7.3 EFV could interfere with necessary operation or maintenance activities such as blowing liquids from the line.
 - 4.7.4 EFV meeting the required performance standards of 49 CFR §192.381 is not available.
- 4.8 Customer Request to Install an EFV
 - 4.8.1 Existing natural gas customers shall receive annual notification of their right to request an EFV to be installed on their existing service line. Annual notification is through the direct mailing of electronic billing insert of the Natural Gas Safety Flyer, see [PUBL 3](#) for the Flyer.
 - 4.8.2 Installation of an EFV at the customer's request will be at the customers expense.
 - 4.8.3 An EFV requested by a customer will not be installed on customer service line with a rated meter capacity greater than 1,000 SCFH.

Or

UNCONTROLLED IF PRINTED

4.8.4 The service line inlet pressure drops below 10 psig.

4.8.5 Customer's request cannot be fulfilled because of [4.8.3](#) or [4.8.4](#) above they shall be notified why their request is denied.

5.0 EFV Installation and Location (49 CFR §192.381)

5.1 Single family residence, multi-meter, commercial services, and farm taps.

5.1.1 EFV shall be installed as close as practical to the outlet of the service tee. Exceptions must be approved by Engineering. See [Appendix A-1](#).

5.1.2 EFV shall be installed with the arrow pointing toward the meter, indicating the direction of flow.

5.1.3 Care should be taken not to allow dirt or debris to get into the EFV.

5.1.4 Care should be taken on steel installations to keep wrenches and welding flames away from the center of the EFV assembly to prevent possible damage of the mechanism.

1. A wet rag shall be placed over the center of the EFV when the valve is being welded in place.

5.2 Farm Tap

5.2.1 On a residential or commercial farm tap serving no more than two (2) service risers:

1. Install a 3/4 inch steel EFV at the outlet of the high pressure distribution service tee. See [Appendix A-5](#).
2. A second properly sized EFV shall be installed at the outlet riser(s) of the farm tap for the primary service line(s). See [Appendix A-5](#).
3. If there is a branch service line off of the primary service line, a separate properly sized EFV can be installed on the branch as stated in [4.1.2](#) above.

5.3 Pressure Testing with an EFV

5.3.1 The pressure test for service with an EFV can be applied from the service tee or the riser termination.

5.3.2 Pressure shall be applied slowly.

If applied too quickly from the service tee, the EFV may trip.

5.3.3 If the EFV closes

1. The pressure downstream of the EFV will eventually equalize due to the small bleed-by feature built into the EFV.
2. The pressure equalization could take as long as 10 minutes depending on the test pressure and service line length.
3. The test may resume when the pressure has equalized.

5.3.4 After a successful pressure test:

1. The main can then be tapped and the service purged.

2. The service tee punch should be withdrawn slowly from the main to control the gas flow and prevent tripping the EFV.

5.3.5 Perform a functional flow test

1. Close the meter valve and disconnect between the meter valve and regulator.
2. Pressurize the service line up to the meter valve.
3. Rapidly open the meter valve to exhaust the pressure.
4. Excessive surge in flow will activate the EFV if properly installed.
5. After activation, close the meter valve.
6. Reconnect the meter set.
7. Initiate gas service to the customer.

5.3.6 Resetting the EFV

1. If an EFV is activated due to a service line break it will reset after the service line pressure is equalized as a result of squeezing off the service line upstream of the break or reconnecting the service line. See [5.3.3](#) for more information.

6.0 EFV Sizing

- 6.1 The EFV diameter size should match the size of the service line.

- 6.1.1 As an example, ½ inch EFV on a ½ inch service.

Service line shall not be reduced in size downstream of the EFV to the inlet of the service riser.

- 6.2 For existing odd size service lines such as 1-1/4", 1-1/2" or 3", Gas Engineering will evaluate the service and determine if there is a smaller size EFV that would meet the service specifications and load requirements at that location.

- 6.2.1 Examples may include:

1. 1/2" CTS EFV on a 3/4" IPS PE service line.
2. 1" CTS EFV on a 1-1/4" IPS PE service line.
3. 2" IPS EFV on a 3" IPS PE service line.
4. 3/4" IPS Steel EFV on a 1-1/2" IPS steel service line.

- 6.3 Using the tables in [Appendix B](#) select the appropriate EFV based on

- 6.3.1 Service line size

- 6.3.2 Maximum capacity of the meter being specified

- 6.3.3 Service line inlet pressure

- 6.3.4 Length of service line

- 6.3.5 Select an EFV with a trip flow that is greater than the customers load (maximum capacity of the meter) on the service line.

UNCONTROLLED IF PRINTED

1. Example:
 - 1 a. ½" CTS service line
 - 1 b. 60 psig inlet pressure
 - 1 c. Maximum meter capacity of 530 SCFH
 - 1 d. EFV selected from [Table B-1](#) has a capacity of 570 SCFH, but the maximum service line length can only be 960 ft.

If the service line length is greater than 960 ft. then the service line and EFV must be increased in size to ¾" IPS or 1" CTS depending on the actual service length.

6.4 Service line sizing for EFV

- 6.4.1 Any proposed new ½ inch service that may, at any point, have an inlet pressure of less than 20 psig should be upgraded to a 1 inch service and EFV.
- 6.4.2 A ½ in PE pipe may be inserted into the existing steel service line with the following criteria:
 1. Inlet pressure less than 20 psig
 2. Existing service line length of 120 feet or less
 3. Meter capacity of 330 SCFH or less
 4. Under the above conditions upgrading to a 1 inch service line would not be required.

7.0 Requirements for Manual Service Line Shut-off Valve Installation (49 CFR §192.385)

- 7.1 A manual service line shut-off valve shall be installed on any new or replaced residential multifamily or commercial service where an EFV is not available or approved by AIC.
- 7.2 A manual service line shut-off valve shall be installed on high pressure distribution service to any new or replaced farm tap service single family or residential branch service where a steel EFV is not available or approved by AIC.

8.0 Manual Service Line Shut-Off Valve Installation

- 8.1 The location of the manual service line shut-off valve shall be:
 - 8.1.1 As close as practical to the fitting that connects the service line into the main
AND
 - 8.1.2 Safely and easily accessible for operation and maintenance.
- 8.2 If the service line connection to the main is under a roadway, the valve should be located in the nearest area, downstream of the connection, where the valve can be safely accessed and operated.
- 8.3 The shut-off valve shall be installed in a valve box with a lid marked "GAS".
 - 8.3.1 The valve box shall not be supported by the service line.
 - 8.3.2 The valve box shall be aligned to allow easy access for a valve wrench.

- 8.4 On a farm tap, in lieu of a below grade valve an above grade manual shut-off valve can be installed on the outlet of the farm tap to shut off the gas flow on the service line.

9.0 Inspection and Maintenance of Manual Shut-Off Valve (49 CFR §192.385)

- 9.1 The manual service line shut-off valve installed after April 14, 2017 shall be subject to regular scheduled inspection/maintenance with the results documented in Maximo.
- 9.2 Manual service line shut-off valves shall be inspected once every five (5) calendar years not to exceed 63 months.
- 9.3 Inspection shall include ensuring the valve box is accessible, properly aligned and free of debris such that a valve wrench will fit on the valve operator.

The valve does not have to be operated.

10.0 EFV and Manual Shut-Off Valve Identification (49 CFR 192.381)

- 10.1 Locations where an EFV is installed will be identified through the following actions.
- 10.1.1 The service record shall identify that an EFV was installed.
- 10.1.2 The meter set at the residence shall be tagged to identify that an EFV was installed.
- 10.1.3 The riser at the farm tap shall be tagged to identify that an EFV was installed.
- 10.2 The location of manual service line shut-off valves shall be identified on the Gas Service Card Form within ClickMobile and retained in Maximo.

End of Instructions.

Operator Qualification (OQ) Required?

YES.

1191: Maintenance of Service Valves Upstream of Customer Meter

1201: Temporary Isolation of Service Lines and Service Discontinuance

Appendices

[Appendix A - EFV Locations](#)

[Appendix B - EFV Sizing Tables](#)

Attachments

NONE.

Compliance Requirements

49 CFR §192.381 Service lines: Excess flow valve performance standards.

49 CFR §192.383 Excess flow valve installation.

49 CFR §192.385 Manual service line shut-off valve installation.

Reference Documents

UNCONTROLLED IF PRINTED

NONE.

Document Rescission

SERV 2.2 Service Line Installation: Excess Flow Valves or Manual Shut-off Valves, December 15, 2021

Revision Notes

Location of Changes	Summary of Changes
Paragraph 4.3.3 – Small Commercial Customer	Revised- For branch service, an EFV shall be installed on each service line to a small commercial customer
Paragraph 4.9.1 – Customer Request to Install an EFV	Added notification language. Existing natural gas customers shall receive annual notification of their right to request an EFV to be installed on their existing service line. Annual notification is through the direct mailing or electronic billing insert of the Natural Gas Safety Flyer, see PUBL 3 for the Flyer.
Paragraph 4.9.2	Grammatical correction – "customer's" replaces "customers"
Paragraph 4.9.5	Updated Paragraph reference links – 4.8.3 and 4.8.4.

Appendix A - EFV Locations

A-1. EFV Installation for SFR

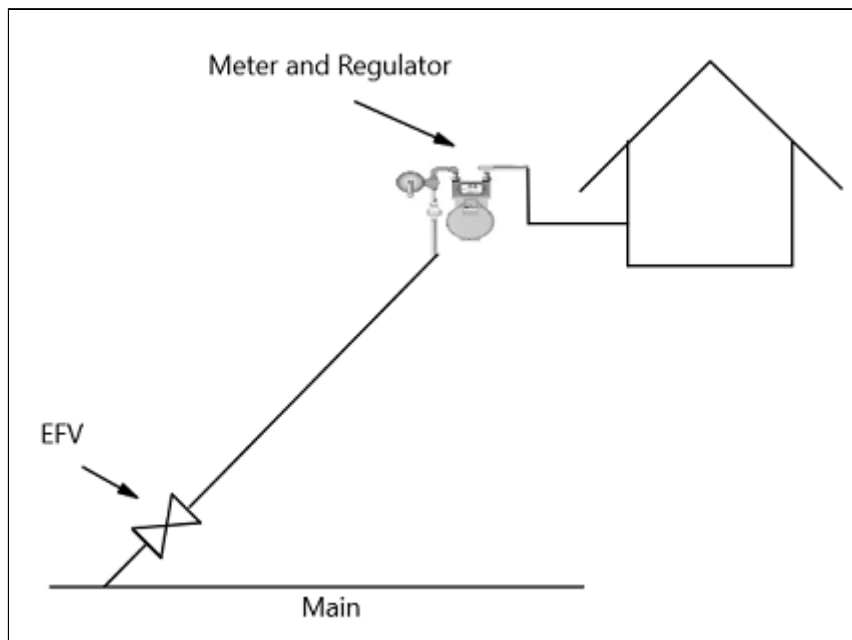

A-2. Single EFV installation on primary service with a branch service

UNCONTROLLED IF PRINTED

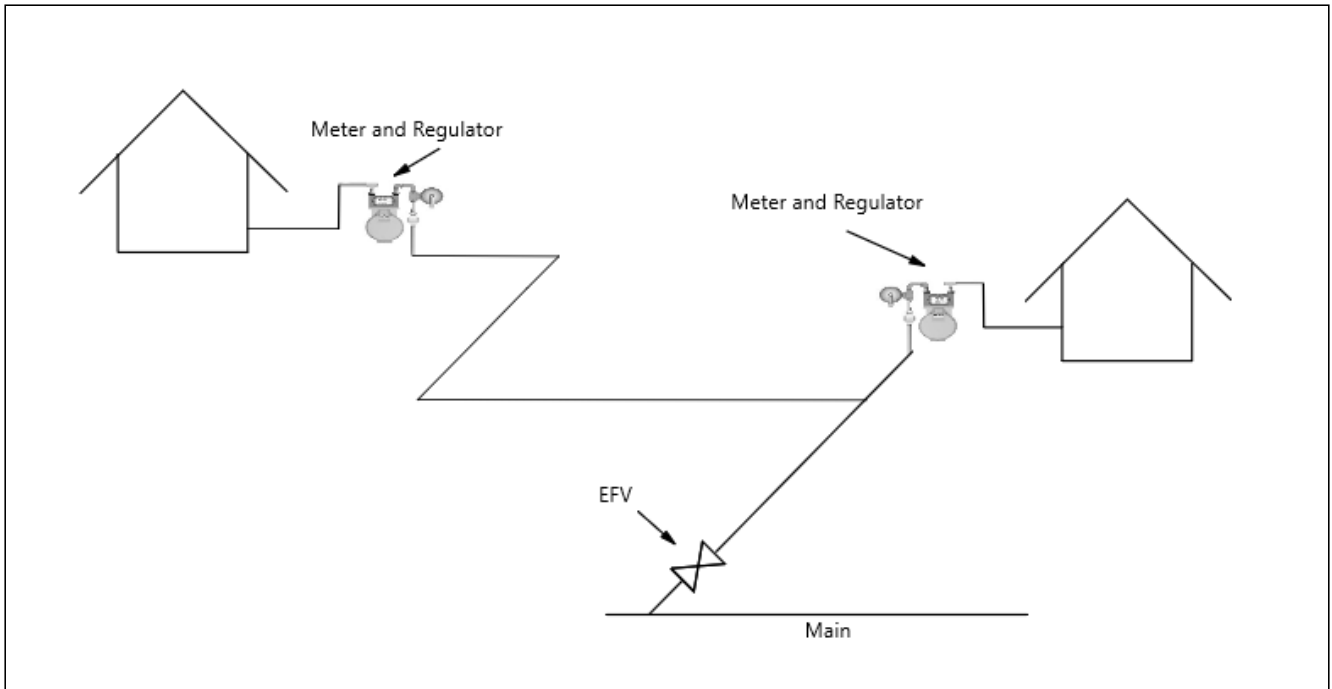

A-3. EFV installation on primary service and branch service

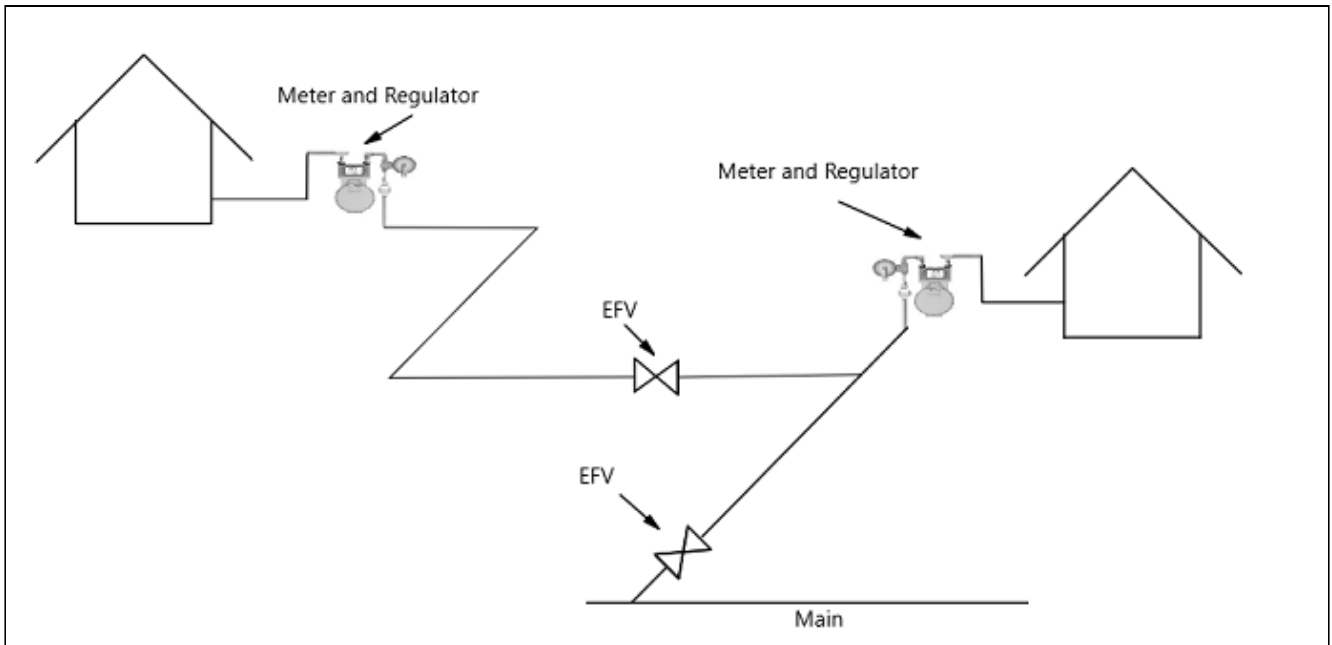

A-4. EFV installation on a new branch service line off an existing primary service line.

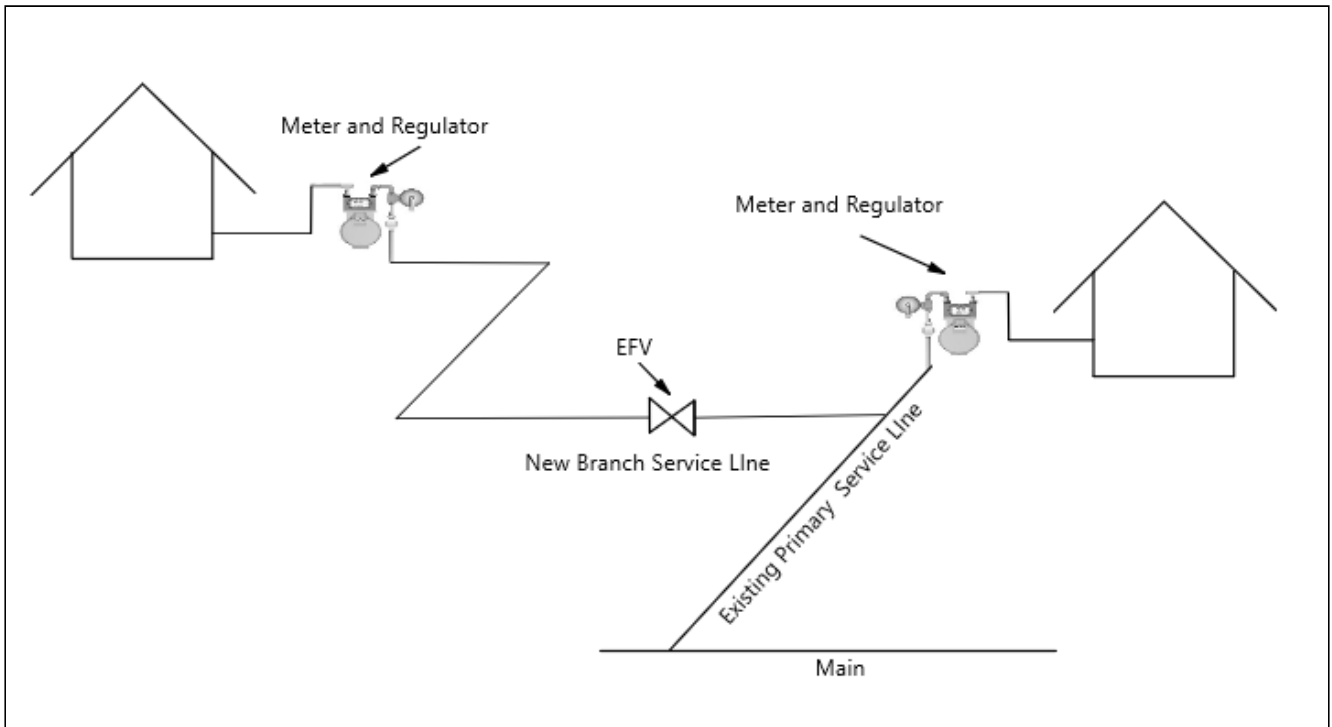

A-5. EFV installation on farm tap

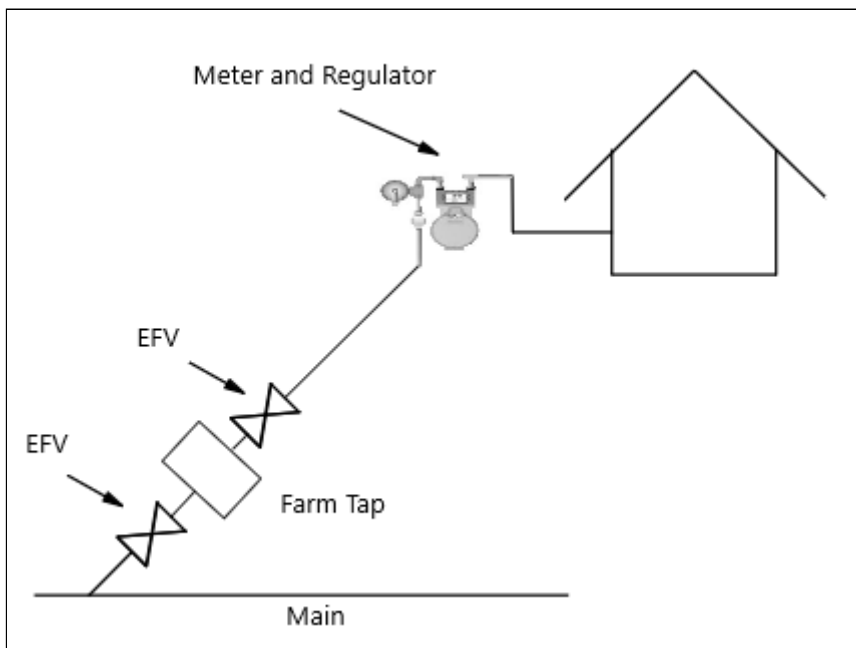

Appendix B - EFV Sizing Tables

B-1. 1/2 inch PE service lines

Inlet Pressure (psig)	Bleed-By Flow (SCFH)	Perfection Series 400 or UMAC Series 350 Stock Code 39 22 097	
		Maximum De- sign Flow (SCFH)	Maximum Length (Feet)

UNCONTROLLED IF PRINTED

20	24	390	330
30	28	440	490
40	30	490	630
50	33	530	800
60	35	570	960
70	38	610	1,170
80	40	650	1,320
90	42	680	1,490
100	44	710	1,660
125	62	793	1,899

B-2. 1 inch CTS

Inlet Pressure	Bleed-By Flow	Stock No 39 22 106 – 1"CTS		Stock No 39 22 551 – 1"CTS		Stock No 39 22 550 – 1"CTS	
		Perfection Series 800 or UMAC Series 700		Perfection Series or UMAC Series 1100		UMAC Series 1800	
		Maximum Design Flow	Maximum Length	Maximum Design Flow	Maximum Length	Maximum Design Flow	Maximum Length
(psig)	(SCFH)	(SCFH)	(Feet)	(SCFH)	(Feet)	(SCFH)	(Feet)
10	20	630	1,000	910	260	1,800	250
15	23	680	1,980	1,000	740	2,020	410
20	24	750	3,160	1,080	1,340	2,250	540
30	28	860	5,830	1,230	2,760	2,520	860
40	30	950	7,710	1,360	3,730	2,790	1,160
50	33	1,070	8,930	1,480	4,400	3,060	1,440
60	35	1,150	10,540	1,590	5,180	3,420	1,630
70	38	1,230	11,900	1,690	5,950	3,690	1,870
80	40	1,300	13,790	1,790	6,830	3,870	2,190
90	42	1,370	15,820	1,885	7,530	4,050	2,500
100	44	1,430	17,850	1,975	8,470	4,230	2,810
125	62	1,498	24,749	2,180	10,968	3,964	3,615

B-3. 1 inch CTS higher capacity

Inlet Pressure	Bleed-By Flow	Stock No 39 22 631 – 1"CTS	
		UMAC Series 2600	
		Maximum Design Flow	Maximum Length

UNCONTROLLED IF PRINTED

(psig)	(SCFH)	(SCFH)	(Feet)
20	25	2600	300
30	28	2910	500
40	32	3220	700
50	35	3500	890
60	37	3770	1,100
70	39	4010	1,290
80	41	4240	1,490
90	46	4460	1,700
100	50	4670	1,900
125	62	5,154	2,422

- 1) Approved for service lines with a minimum operating pressure of 20 psig or greater.
- 2) These EFV's are not to be installed on service lines where pressure can drop below 20 psig

B-4. 2 inch IPS higher capacity

Inlet Pressure	Bleed-By Flow	Stock No 39 22 634 - 2"IPS		Stock No 39-22-639	
		UMAC Series 2600		UMAC Series 5500	
		Maximum Design Flow	Maximum Length	Maximum Design Flow	Maximum Length
(psig)	(SCFH)	(SCFH)	(Feet)	(SCFH)	(Feet)
20	25	2600	10,630	5430	3,650
30	28	2910	17,510	6160	5,310
40	32	3220	24,350	6820	6,950
50	35	3500	31,210	7420	8,580
60	37	3770	38,110	7970	10,220
70	39	4010	45,060	8490	11,870
80	41	4240	50,080	8980	13,530
90	46	4460	59,150	9440	15,200
100	50	4670	66,280	9880	16,880
125	62	5,154	84,322	10,902	21,124

- 1) Approved for service lines with a minimum operating pressure of 20 psig or greater.
- 2) These EFV's are not to be installed on service lines where pressure can drop below 20 psig.

B-5. 3/4 inch IPS - Steel EFV

Inlet Pressure (psig)	Bleed-By Flow (SCFH)	Series 700/800 Stock Code 39 22 096	Series 1100 Stock Code 39 22 552	Series 1800 Stock Code 39 22 250

UNCONTROLLED IF PRINTED

		Design Flow (SCFH)	Max Length (Feet)	Design Flow (SCFH)	Max Length (Feet)	Design Flow (SCFH)	Max Length (Feet)
10	20	560	1,434	880	634	1,600	152
15	23	608	2,120	984	938	1,800	253
20	24	664	2,779	1,048	1,230	2,000	351
30	28	768	4,059	1,224	1,797	2,240	542
40	30	848	5,320	1,336	2,356	2,480	731
50	33	960	6,578	1,496	2,914	2,720	919
60	35	1,040	7,841	1,624	3,474	3,040	1,108
70	38	1,128	9,110	1,744	4,036	3,280	1,299
80	41	1,232	10,387	1,840	4,602	3,440	1,491
90	46	1,232	11,672	1,960	5,172	3,600	1,684
100	50	1,280	12,967	2,040	5,742	3,760	1,879
125	62	1,388		2,180		3,964	
150	75	1,424		2,287		4,216	
200	88	1,568		2,663		4,908	
250	115	1,712		2,995		5,520	
300	130	1,856		3,314		6,108	
350	155	2,000		3,629		6,688	
400	175	2,144		3,863		7,120	
450	185	2,288		4,104		7,564	
Inlet Pressure (psig)	Bleed-ByFlow (SCFH)	Series 700/800 Stock Code 39 22 096		Series 1100 Stock Code 39 22 552		Series 1800 Stock Code 39 22 250	
		Design Flow (SCFH)	Max Length (Feet)	Design Flow (SCFH)	Max Length (Feet)	Design Flow (SCFH)	Max Length (Feet)
500	195	2,432	67,475	4,321	30,794	7,964	10,404
550	215	2,576		4,497		8,288	
600	240	2,720		4,655		8,580	
650	260	2,856		4,814		8,872	
700	275	3,000		5,034		9,052	
750	295	3,149		5,244		9,397	
800	310	3,299		5,442		9,717	
850	330	3,448		5,628		10,007	
900	350	3,594		5,798		10,266	
950	370	3,736		5,951		10,490	

UNCONTROLLED IF PRINTED

1000	385	3,875		6,085		10,675	
------	-----	-------	--	-------	--	--------	--

B-6. Reducer Coupling with EFV for Meter Upgrades

Friastop EF Coupling w/EFV, GS15B, 1" CTS x 1/2" CTS Stock Code 39 22 635		
Inlet Pressure PSIG	Maximum Design Flow	Maximum Length Feet
10	496	119
20	588	225
30	668	328
40	739	430
50	803	533
60	863	636
80	972	846
100	1069	1060
125	1180	1333

- 1) Knowing the customer's connected load is important when doing a meter upgrade.
- 2) This EFV should be sized for connected load, not meter capacity.
- 3) This EFV is not approved for any meter above an AL425 at inches water column delivery.

SERVICE LINE INSTALLATION

October 1, 2022

SERV 2.3 Farm Tap Installation

1.0 Purpose

This document provides the requirements Farm Taps. This document meets the requirements of 49 CFR §§ 192.381, 192.382, 192.383, 192.385, 49 CFR Part 192 Subpart J.

2.0 Scope

This document addresses the following:

[3.0 Target Audience](#)[4.0 Farm Requirements](#)[5.0 Farm Tap Locations](#)[6.0 Farm Tap Installations](#)[7.0 Farm Tap Capacity](#)[8.0 Inlet Valves](#)[9.0 Testing](#)

Appendices:

[Appendix A - Farm Taps](#)[Appendix B - Farm Tap Location](#)[Appendix C - Farm Tap Capacity Tables](#)

3.0 Target Audience

- Gas Engineering
- Gas Distribution Design
- Gas Field personnel
- Gas Construction personnel
- Gas Supervisors
- Gas Construction Services personnel

4.0 Farm Requirements

- 4.1 A farm tap is required when the supply source has a MAOP over 125 psig.
- 4.2 A new farm tap shall only be installed within a service line that serves no more than two (2) service risers.
- 4.3 A newly installed gas main shall not be connected to the downstream end of a farm tap.
- 4.4 Once three (3) or more service risers are connected, the existing service line can no longer be classified as a service.
 - 4.4.1 The line shall either be upgraded to a main or replaced with a new main and the farm tap changed to a regulator station.
 - 4.4.2 An upgraded line shall meet the requirements contained in [MAIN 1](#).
- 4.5 Farm tap on a gas pressure system with a Design MAOP greater than 1000 psig shall be designed or reviewed by Gas Tech Engineering (GTE).

UNCONTROLLED IF PRINTED

- 4.6 Pressure containing facilities similar to a farm tap located within gas storage fields and compressor plants shall be designed by Gas Storage Engineering (GSE).
- 4.7 GTE or Integrity Management (IM) may specify that an inspectable farm tap be installed. In which case, GTE shall include the design plans, regulator and relief valve set points and bill of materials in the Job Packet.

5.0 Farm Tap Locations

- 5.1 Farm tap installations shall normally be placed on the customer's property at or near the property line.
- 5.2 When the installation of a service line results in it crossing an adjacent property line, an easement is normally required for the service line.
 - 5.2.1 If that easement allows, the farm tap can be placed on that property.

The main goal is to not have a farm tap installed on public right-of-way.

- 5.3 On a long side service, the farm tap should be placed on the customer side of the road.

If a private easement is obtained, the farm tap may be placed on the same side of the road as the gas main.

- 5.4 Farm taps should be located away from:
 - 5.4.1 Paved areas
 - 5.4.2 Sidewalks
 - 5.4.3 Building entrances
 - 5.4.4 Areas that have heavy vehicular traffic.
- 5.5 Guard posts should be installed around the farm tap if additional protection from vehicular or other forms of damage is needed.
 - 5.5.1 Protective Barricades are available with 2" legs (62 05 159) and 4" legs (62 05 160).
- 5.6 Pipeline markers should be installed at farm taps located in areas where vegetation growth may inhibit visibility. See [PMRK 1](#)
- 5.7 Refer to [Appendix B](#) Farm Tap Location for a typical installation.

6.0 Farm Tap Installations

- 6.1 Farm Tap Type
 - 6.1.1 Single-Cut: 60-450 PSIG inlet MAOP with outlet pressure between 15 and 20 psig. Refer to [Appendix A-1](#)
 - 6.1.2 Double-Cut: 451-1000 PSIG inlet MAOP. 1st step outlet pressure of 100 psig and 2nd step outlet pressure between 15 and 20 psig. Refer to [Appendix A-2](#)
- 6.2 Regulator Set points

6.2.1 Single-cut farm tap the regulator set point shall be between 15 psig and 20 psig.

6.2.2 Double-cut farm tap

1. First cut - 100 psig
2. First cut relief valve - 120 psig
3. Second cut - 20 psig
4. Second cut relief valve - 30 psig

6.3 Farm tap EFV - refer to [SERV 2.2](#) Excess Flow Valves or Manual Shut-off Valve.

6.4 Installation Notes:

6.4.1 The ¾" steel inlet riser can be field bent with a minimum bending radius of 13".

6.4.2 Tracer wire for a plastic service line should be brought above ground at the outlet riser from the farm tap.

6.4.3 Install a 5 lb. anode on the tracer wire near the farm tap outlet.

6.4.4 Do not bond the tracer wire to the farm tap piping.

6.4.5 All welded joints, valves, and the punch tee shall be coated and wrapped according to [CORR 2.3](#) Coatings.

6.4.6 Install the 627R regulator so that the relief is vented downward.

6.4.7 For the maximum flow rates and bleed rates of the EFVs, see [SERV 2.2](#) for excess flow valves (EFV) sizing.

7.0 Farm Tap Capacity

7.1 The tables in this section indicate the flow capacities for the regulators and EFVs in the standard farm tap installations. When checking that a farm tap will have enough capacity, the following items need to be considered:

7.1.1 MAOP of the inlet line from the tapped main or transmission line.

7.1.2 The current operating pressure of the tapped main or transmission line.

7.1.3 The customer's peak gas load.

7.1.4 The maximum flow rate of the inlet (HP) EFV.

7.1.5 The maximum flow rate of the outlet (IP) EFV (if installed).

7.2 Refer to [Appendix C](#) Farm Tap Capacity Tables for determining farm tap capacities.

8.0 Inlet Valves

8.1 The single-cut and double-cut farm taps shall have an above-ground valve located upstream of the regulator.

8.2 The options available for installing additional below grade inlet valves, depends on the size of the transmission or high pressure distribution supply line, location, ease of access and customer being served, are:

8.2.1 For all farm tap designs, an optional weld Mueller H-17900 valve can be installed in the service line.

See [Appendix A-1](#) Single Cut or [Appendix A-2](#) Double Cut farm tap.

This valve shall be installed in a location as close to the main as practical and in an area where a valve box can be maintained and easily located.

Or

- 8.2.2 Install a Mueller H-17656 valve tee at the service tap on the main in lieu of a Mueller H-18101 (AUTOPERF) tee.

The valve tee would have to be uncovered in order to shut-off the gas flow.

Or

- 8.2.3 Install a Mueller H-17800 curb valve tee as the service tap on the main in lieu of an AUTOPERF tee or H-17656 valve tee.

For easy access, a valve box can be installed over this valve.

Where the wall thickness of the pipe cannot be verified to be 0.281 inches or less, a Mueller H-17656 valve tee or Mueller H-17800 curb valve tee shall be used in place of an AUTOPERF tee.

- 8.3 If there is a future possibility of upgrading the farm tap to a regulator station, install either a Mueller H-17900 or H-17800 as a station valve.

- 8.3.1 The valve should be located a minimum of twenty (25) feet upstream of the farm tap inlet riser.

9.0 Testing

- 9.1 Farm tap piping shall be tested in accordance with the following tables

9.1.1 Single-Cut: Ameren document [PTST 1.1](#).

9.1.2 Double-Cut: Ameren document [PTST 1.1](#).

- 9.2 Once the farm tap has been installed, the outlet pressure should be

9.2.1 Checked and adjusted as needed.

9.2.2 On a double-cut farm tap, the outlet pressure of the first cut regulator should also be checked and adjusted.

Pressure gauges should be removed when completed.

- 9.3 All connections between the inlet riser and outlet riser shall be checked for leaks with leak detection fluid or leak detection instrument at current operating pressure after regulator(s) and relief valve are installed.

End of Instructions.

Operator Qualification (OQ) Required?

YES

- 0301: Manually Opening and Closing Valves
- 0311: Adjust and Monitor Flow or Pressure - Manual Valve Operation
- 0861: Installation of Steel Pipe in a Ditch
- 0871: Installation of Steel Pipe in a Bore
- 0901: Installation of Plastic Pipe in a Ditch
- 0911: Installation of Plastic Pipe in a Bore
- 0941: Install Tracer Wire
- 0951: Installation of Pipe Above Ground
- 0961: Above-Ground Supports and Anchors: Inspection, Preventative, and Corrective Maintenance
- 0981: Backfilling
- 1081: Tapping a Pipeline (Tap Diameter 2 in. and Less)
- 1161: Installation of Customer Meters and Regulators - Residential and Small Commercial.
- 1171: Installing Customer Meters: Large Commercial and Industrial
- 1191: Maintenance of Service Valves Upstream of Customer Meter

Appendices

[Appendix A - Farm Taps](#)

[Appendix B - Farm Tap Location](#)

[Appendix C - Farm Tap Capacity Tables](#)

Attachments

NONE.

Compliance Requirements

49 CFR Part 192 Subpart H - Customer Meters, Service Regulators, and Service Lines

Reference Documents

[CORR 2.3 Corrosion Control: Coatings](#)

[CORR 2.4 Corrosion Control: General Wrapping Instructions](#)

[MAIN 1 Main Installation: Requirements](#)

[PMRK 1 Pipeline Markers: Requirements](#)

UNCONTROLLED IF PRINTED

[PTST 1 Pressure Testing: Requirements](#)

[SERV 2.2 Service Line Installation: Excess Flow Valves or Manual Shut-off Valve](#)

[STLP 2.1 Steel Pipe: Design Pressure](#)

[TAPS 2.5 Tapping and Stopping: Mueller Autoperf Tee](#)

Document Rescission

SERV 2.3 Service Line Installation: Farm Tap, February 22, 2022

Revision Notes

Location of Changes	Summary of Changes
Subsection 4.1	MAOP replaces operating pressure
Subsection 4.5	Removed = states basically the same as 4.1
Paragraph 6.1.1	MAOP replaces pressure
Paragraph 6.1.2	MAOP replaces pressure
Appendix A-1 Single Farm Tap	MAOP replaces pressure
Appendix A-2 Double Cut Farm Tap	MAOP replaces pressure
Appendix A-2 Double Cut Farm Tap Material List	Item 19 – Corrected the description of the Riser. Matched A-1 Material List riser description

Appendix A - Farm Taps

A-1. Single-Cut, 60 - 450 PSIG Inlet MAOP

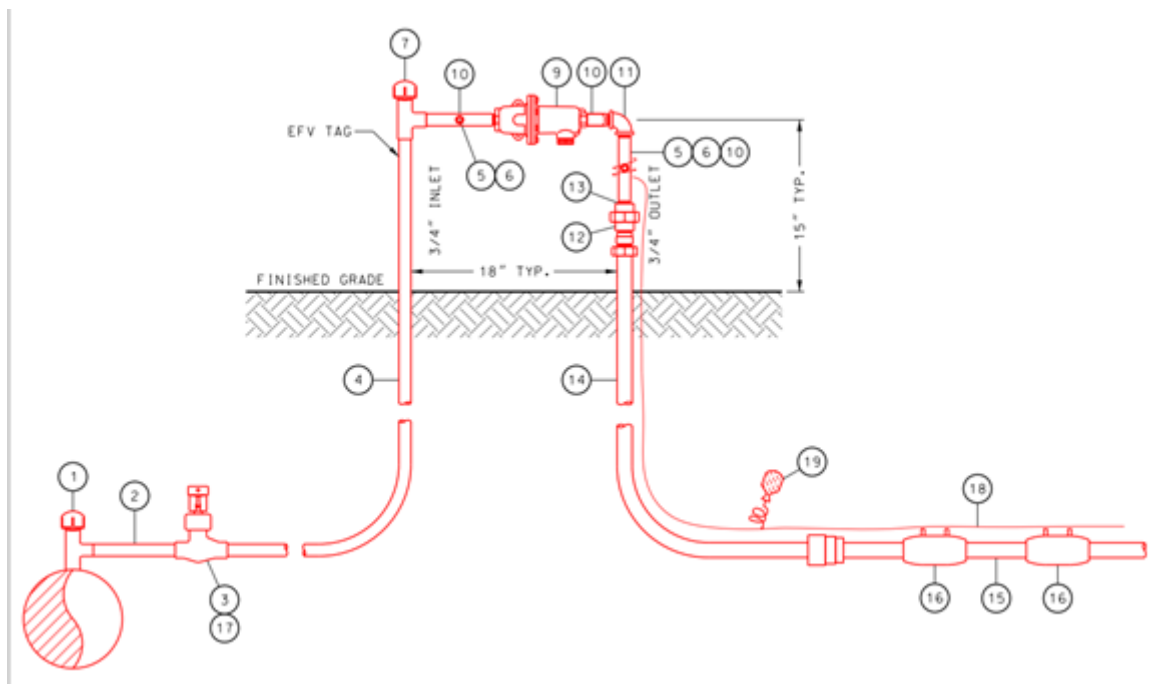

UNCONTROLLED IF PRINTED

Bill of Material G351101			
Item	Stock No.	Description	01
1	19 23 192	Tee, Service, Weld, ¾" x 1", 5/16" punch, Mueller H-18101, AUTOPERF (See Note)	1
	19 23 203	Tee, Valve, Weld, 1" x 1", 1440#, Mueller H-17656 (optional)	
	19 12 229	Tee, Curb Valve, Weld, 1" x 1", 1440#, Mueller H-17800 (optional)	
2	39 22 096	Valve, Excess Flow, Steel, ¾", Weld End, Series 700/800	1
3	39 22 148	Valve, Weld, 1", Mueller H-17900 (optional)	1
4	32 23 302	Pipe, Steel, Coated, ¾", Schedule 40	X
5	19 15 144	Fitting, Threadolet, ¼", 3000#, Weld x Thread	2
6	19 62 595	Plug, Pipe, ¼", Hex, MNPT, Brass, Pete's Plug	2
7	19 23 203	Tee, Valve, Weld, 1" x 1", 1440#, Mueller H-17656	1
8		Replaced by item 10	
9	62 06 123	Regulator, Pressure, ¾", Fisher 627R, 1/8" Orifice, 5-20# Spring	1
10	19 72 163	Nipple, Pipe, ¾" x 6", Schedule 80	3
11	19 23 901	Elbow, Pipe, ¾", 90 Degree, 3000#, FNPT, FS	1
12	19 83 139	Union, Pipe, 1", 3000#, FNPT, FS	1
13	19 73 972	Bushing, Pipe Reducing, Hex, 1" x ¾", 6000#, MNPT x FNPT, FS	1
14	19 17 044	Riser, Service, Anodeless, 1" IPS x 1" CTS, Rigid, PE2406/PE2708, SDR 11.5 (Use only for PE2406/PE2708 1" service line)	1
15	39 22 551	Valve, Excess Flow, 1" CTS x 0.101" Wall, PE3408/PE4710, Series 1100	1
16	19 22 506	Coupling, Pipe, 1" CTS, Electrofusion, PE3408/PE4710	2
17	19 72 128	Box, Valve, Gas (optional)	1
18	18 66 369	Wire, Tracer, #12 AWG, Cu	X
19	62 05 082	Anode, Magnesium, 5 LB	1

X - Number of feet required for specific installation.

Note: Item 1: Maximum wall thickness that Mueller H-18101 can tap is 0.281 inches. If the pipe wall thickness is not known or cannot be verified through testing or experience to be less than 0.281, a Mueller valve tee, H-17656, or Mueller curb valve tee, H-17800, should be used in place of the AUTOPERF tee.

See [TAPS 2.5](#) Maximum Pipe Wall Thickness for AUTOPERF Tee.

See [STLP 2.1](#) Steel Pipe Stock Code Table for wall thickness of stock coded steel pipe.

A-2. Double-Cut, 451-1000 PSIG Inlet MAOP

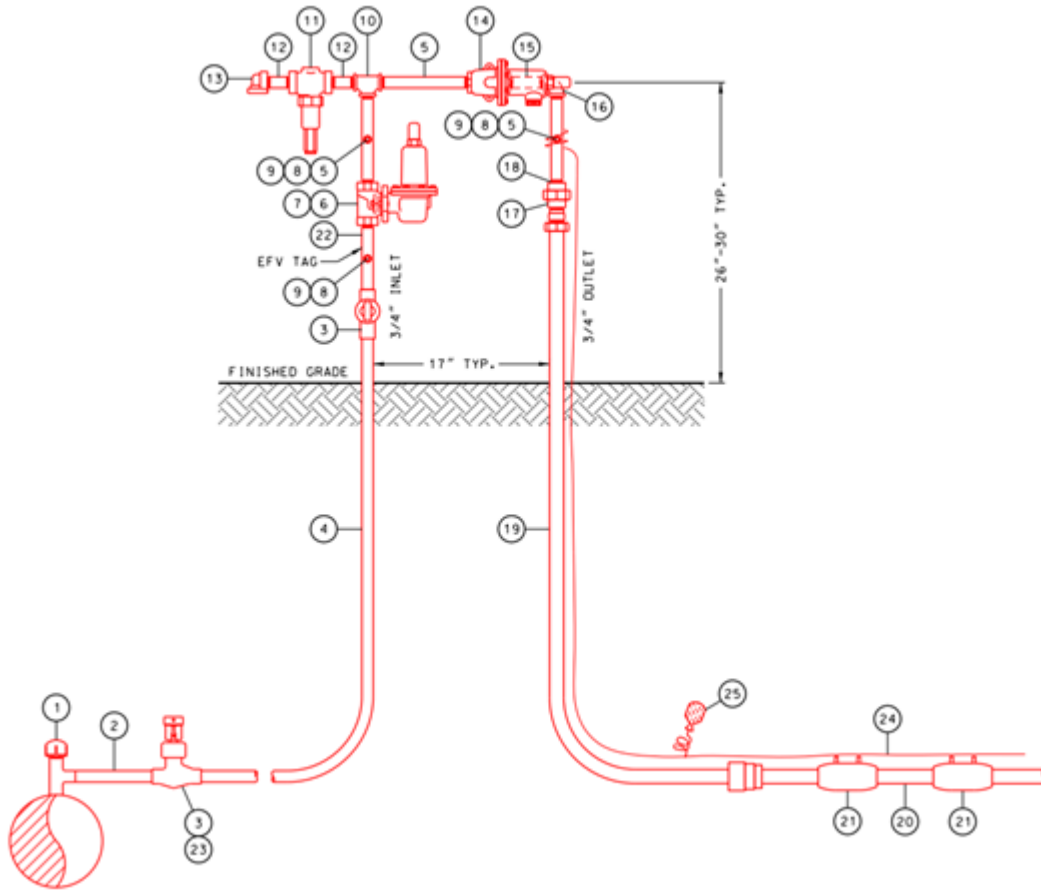

Bill of Material G353101			
Item	Stock No.	Description	01
1	19 23 192	Tee, Service, Weld, 3/4" x 1", 5/16" punch, Mueller H-18101, AUTOPERF (See Note)	1
	19 23 203	Tee, Valve, Weld, 1" x 1", 1440#, Mueller H-17656 (optional)	
	19 12 229	Tee, Curb Valve, Weld, 1" x 1", 1440#, Mueller H-17800 (optional)	
2	39 22 096	Valve, Excess Flow, Steel, 3/4", Weld End, Series 700/800	1
3	39 22 148	Valve, Weld, 1", Mueller H-17900 (below ground valve optional)	2
4	32 23 302	Pipe, Steel, Coated, 3/4", Schedule 40	X
5	19 83 036	Nipple, Pipe, 3/4" x 8", Schedule 80	3
6	62 06 202	Regulator, Pressure, 3/4", Fisher 627, 3/32" Orifice, 70-150# Spring	1
7	19 33 674	Elbow, Pipe, Street, 3/4", 90 Degree, Threaded, MI	1
8	19 15 144	Fitting, Threadolet, 1/4", 3000#, Weld x Thread	3
9	19 62 595	Plug, Pipe, 1/4", Hex, MNPT, Brass, Pete's Plug	3
10	19 33 224	Tee, Pipe, 3/4" x 3/4" x 3/4", FS, Threaded, 3000 psig	1
11	39 22 147	Valve, Relief, 3/4", Fisher 1805, 20-125# Spring	1
12	19 33 677	Nipple, Pipe, 3/4" x 2", Schedule 80	2
13	62 56 231	Vent, Regulator, 3/4", Female, Angle	2
14	62 06 123	Regulator, Pressure, 3/4", Fisher 627R, 1/8" Orifice, 5-20# Spring	1
15	19 83 030	Nipple, Pipe, 3/4" x 3", Schedule 80	1
16	19 23 901	Elbow, Pipe, 3/4", 90 Degree, , 3000#, FNPT, FS	1
17	19 83 139	Union, Pipe, 1", , 3000#, FNPT, FS	1
18	19 73 972	Bushing, Pipe Reducing, Hex, 1" x 3/4", 6000#, MNPT x FNPT, FS	1

UNCONTROLLED IF PRINTED

19	19 17 044	Riser, Service, Anodeless, 1" IPS x 1" CTS, Rigid, PE2406/PE2708, SDR 11.4 (Use only for PE 2406/PE2708 1" service line).	1
20	39 22 551	Valve, Excess Flow, 1" CTS x 0.101" Wall, PE3408/PE4710, Series 1100	1
21	19 22 506	Coupling, Pipe, 1" CTS, Electrofusion, PE3408/PE4710	2
22	19 72 163	Nipple, Pipe, 3/4" x 6", Schedule 80 (threads cut off 1 end)	1
23	19 72 128	Box, Valve, Gas (optional)	1
24	18 66 369	Wire, Tracer, #12 AWG SLD, Cu	X
25	62 05 082	Anode, Magnesium, 5 LB	1

X - Number of feet required for specific installation.

Note: Item 1: Maximum wall thickness that Mueller H-18101 can tap is 0.281 inches. If the pipe wall thickness is not known or cannot be verified through testing or experience to be less than 0.281, a Mueller valve tee, H-17656, or Mueller curb valve tee, H-17800, should be used in place of the AUTOPERF tee.

See [TAPS 2.5](#) Maximum Pipe Wall Thickness for AUTOPERF Tee.

See [STLP 2.1](#) Steel Pipe Stock Code Table for wall thickness of stock coded steel pipe.

Appendix B - Farm Tap Location

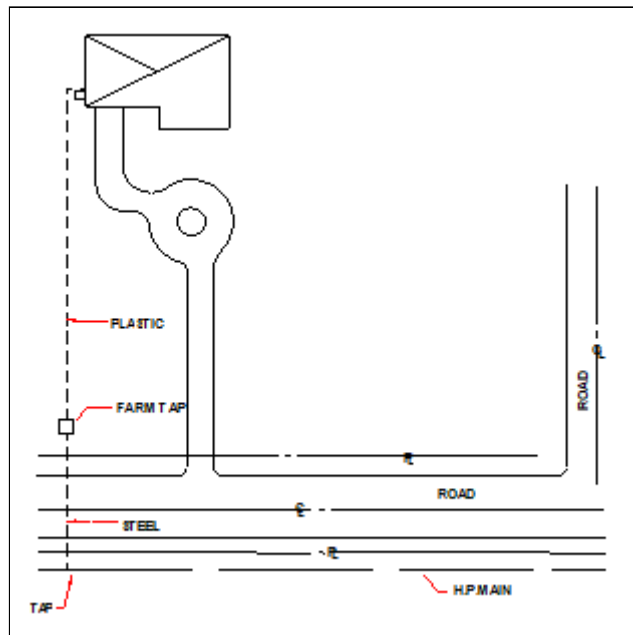

Appendix C - Farm Tap Capacity Tables

C-1. Single-Cut Farm Tap Capacity (3/4" Fisher 627R, 1/8" orifice, 20# set point)
(Also 2nd cut regulator for double-cut farm tap)

Inlet Pressure	Outlet Capacity (CFH)	Stock Code 39 22 096 HP EFV Max Flow (CFH)	Stock Code 39 22 552 HP EFV Max Flow (CFH)	Stock Code 39 22 250 HP EFV Max Flow (CFH)
50	980	960	1,496	2,720
60	1,170	1,040	1,624	3,040
100	1,810	1,280	2,040	3,760
150	2,600	1,424	2,287	4,216

UNCONTROLLED IF PRINTED

200	3,400	1,568	2,663	4,908
300	4,980	1,856	3,314	6,108
400	5,090	2,144	3,863	7,120
450	5,145	2,288	4,104	7,564

Notes:

1. Highlighted HP EFV flow rates above have a trip rate lower than the farm tap capacity.
2. Max flow for ½" outlet EFV at 20 psig = 390 CFH
3. Max flow for 1" outlet EFV at 20 psig = 750 CFH (See [SERV 2.2](#) 1" EFV options)
4. Maximum inlet pressure to maintain the internal relief capacity is 490 psig.

C-2. Double-Cut Farm Tap - 1st Cut Regulator Capacity (¾" Fisher 627, 3/32" orifice, 70-150 psig)

Inlet Pressure	Outlet Capacity (CFH)	Stock Code 39 22 096 HP EFV Max Flow (CFH)	Stock Code 39 22 552 HP EFV Max Flow (CFH)	Stock Code 39 22 250 HP EFV Max Flow (CFH)
100	990	1,280	2,040	3,760
200	1,850	1,568	2,663	4,908
300	2,700	1,856	3,314	6,108
400	3,549	2,144	3,863	7,120
500	4,400	2,432	4,321	7,964
750	6,600	3,149	5,244	9,397
1,000	8,700	3,875	6,085	10,675

Notes:

1. Highlighted HP EFV flow rates above have a trip rate lower than the farm tap capacity.
2. The trip flow rates for the outlet EFV are listed above.

SERVICE LINE INSTALLATION

October 1, 2020

SERV 2.4 Yardlines

1.0 Purpose

This document defines what a yardline is and provides a uniform practice for the installation, operation and maintenance of existing underground residential customer fuel lines that are considered to be yardlines. This document meets the requirements of 220 ILCS 20/2.02.5 and 2.03 of the Illinois Gas Pipeline Safety Act and 49 CFR §192.723 (b)(2).

2.0 Scope

This document addresses the following:

[3.0 Target Audience](#)[4.0 Yardline Definition](#)[5.0 Yardline Operation and Maintenance](#)[6.0 Yardline Installations](#)[7.0 Yardline Elimination](#)[8.0 Yardline Records](#)**3.0 Target Audience**

- Gas Engineering
- Gas Field personnel
- Gas Supervisor
- Gas Construction personnel
- Gas Supervisors

4.0 Yardline Definition

- 4.1 A yardline is an underground primary fuel line for a residential customer that transports gas from the service line (meter outlet) to the customer's building, including manufactured homes and multiple unit buildings.
- 4.1.1 If multiple buildings are served from one meter, "building" means the first building nearest to the service line connection.
- 4.1.2 If the meter is located within three (3) feet of a building being served by the meter, the meter shall be considered at the building and no yardline exists. Refer to 220 ILCS 20/2.02.5
- 4.1.3 If the meter is greater than three (3) feet from the residential building wall, the underground fuel line from the meter to the entrance into the nearest building served by that meter shall be considered a yardline.
- 4.2 Underground commercial or industrial fuel lines where the meter is located more than three (3) feet from the building being served by the meter are not considered yardlines.

5.0 Yardline Operation and Maintenance

- 5.1 The Illinois Commerce Commission requires Ameren Illinois to operate all yardlines defined in [Section 4.0](#).

- 5.2 Ameren Illinois shall perform a leak survey of all yardlines every three (3) calendar years not to exceed thirty-nine months. Refer to 49 CFR §192.723 (b)(2)

6.0 Yardline Installations

- 6.1 Ameren Illinois will require all new residential meter sets to be installed within three (3) feet of the building, including manufactured homes and multiple unit buildings, avoiding the creation of new yardlines.

7.0 Yardline Elimination

- 7.1 Ameren Illinois' long-term objective is to eliminate all yardlines, with longer and older yardlines being eliminated first.
- 7.2 The Gas Supervisor shall use all available opportunities to eliminate existing yardlines.

A Yardline from a single meter to a residential dwelling can be eliminated by relocating the service riser and meter to within three (3) feet of the dwelling provided the yardline pipe can be connected to the existing service line pipe and passes the required leak test.

- 7.3 When a yardline is eliminated Maximo shall be updated with the removal.

8.0 Yardline Records

- 8.1 The Gas Supervisor shall maintain a list of all existing yardlines in Maximo.
- 8.2 The yardlines shall be leak surveyed in accordance with [Section 5.2](#) and [LEAK 2.7](#).
- 8.3 Yardline survey information will be entered within ClickMobile and maintained in Maximo. Refer to [LEAK 2.8](#).

End of Instructions.

Operator Qualification (OQ) Required?

NO.

Appendices

NONE.

Attachments

NONE.

Compliance Requirements

Illinois Gas Pipeline Safety Act 220 ILCS 20/2.02.5

Illinois Gas Pipeline Safety Act 220 ILCS 20/2.03

49 CFR §192.723 (b)(2) Distribution systems: Leakage surveys.

Reference Documents

[LEAK 2.7 Leak Management: Mobile Leak Surveys](#)

UNCONTROLLED IF PRINTED

[LEAK 2.8 Leak Management: Survey Maps and Records](#)

Document Rescission

SERV 2.04 Service Line Installation: Yardlines, December 1, 2014.

Revision Notes

Location of Changes	Summary of Changes
Not applicable.	This is a new document.

SERVICE LINE INSTALLATION

October 1, 2020

SERV 2.5 Inactive Services

1.0 Purpose

This document provides a uniform practice of tracking, reporting, assessing, and retiring inactive gas services. 49 CFR §192.727.

2.0 Scope

This document addresses the following:

[3.0 Target Audience](#)

[4.0 Inactive Service Definition](#)

[5.0 Maintenance of Inactive Services](#)

[6.0 Tracking and Reporting of Inactive Services](#)

[7.0 Inactive Service Retirements](#)

3.0 Target Audience

- Gas Engineering
- Gas Supervisor
- Gas Service personnel
- Gas Construction personnel

4.0 Inactive Service Definition

4.1 Inactive Service - A gas service is considered to be inactive when there is no longer a customer of account.

When there is a customer of account, the service is considered to be active.

5.0 Maintenance of Inactive Services

5.1 All inactive gas services shall be maintained and operated in the same manner as an active gas service.

5.2 Maintenance includes:

5.2.1 Performing leak surveys

5.2.2 Cathodic protection readings (if applicable)

5.2.3 Atmospheric corrosion surveys

5.2.4 Any other applicable code compliance inspections or surveys as defined in the Ameren Illinois O&M Plan.

6.0 Tracking and Reporting of Inactive Services

6.1 The identification and location of inactive services will be tracked and maintained within the Ameren Illinois Customer Service System (CSS).

UNCONTROLLED IF PRINTED

- 6.2 CSS maintains the gas meter removal date which identifies when a gas service became inactive.
- 6.3 A report will be generated from CSS each year, or more often if requested, that identifies gas services that have been inactive for eight years, nine years, and ten or more years.
- 6.4 The report will be provided to the Gas Supervisor in each Region by Gas Operation and Services.

7.0 Inactive Service Retirements

- 7.1 The Gas Supervisor is responsible for reviewing the CSS inactive service report once each year to identify any services that have been inactive for ten or more years.
- 7.2 Each service that is identified as being inactive for ten or more consecutive years should be:
 - 7.2.1 Retired (cut-off) within one year
 - Or
 - 7.2.2 Assessed to determine if the inactive service still has value and should remain tied to the gas system.
 - 1. The assessment should be documented and include the following:
 - 1 a. Leak survey the inactive service line. Refer to [LEAK 2.4](#) and [LEAK 2.8](#).
 - 1 b. Perform a pipe to soil reading, if applicable, for acceptable cathodic protection. Refer to [CORR 2.8](#).
 - 1 c. Assess the condition of the inactive service riser including looking for evidence of atmospheric corrosion, corrosion at the pipe to soil interface, or disbonded coating. Refer to [LEAK 2.4](#) and [CORR 1](#).
 - 1 d. Review riser accessibility including an undesirable location such as an inside meter. Refer to [SERV 1](#).
 - 1 e. Verify the inactive service is documented and being maintained in the same manner as an active service; i.e. service record card, CSS record, AM/FM premise, etc.
- 7.3 If an inactive service is determined to have value and will not be retired or removed then:
 - 7.3.1 A reassessment should be performed and documented every five years after the initial assessment.
 - 7.3.2 The date of the inactive service assessment must be recorded in CSS.
- 7.4 An inactive service may be retired before ten consecutive years of inactivity at the discretion of the Gas Supervisor.

End of Instructions.

Operator Qualification (OQ) Required?

YES

0001: Measure Structure-to-Electrolyte Potential

UNCONTROLLED IF PRINTED

- 0011: Conduct Close Interval Survey
- 0021: Measure Soil Resistivity
- 0141: Visual Inspection for Atmospheric Corrosion
- 1161: Installation of Customer Meters and Regulators - Residential and Small Commercial
- 1171: Installing Customer Meters - Large Commercial and Industrial
- 1201: Temporary Isolation of Service Lines and Service Discontinuance
- 1261: Walking Gas Leakage Survey
- 1291: Locate Underground Pipelines

Appendices

NONE.

Attachments

NONE.

Compliance Requirements

49 CFR §192.727 Abandonment or deactivation of facilities.

Reference Documents

[CORR 1 Corrosion Control: Requirements](#)

[CORR 2.4 Corrosion Control: Corrosion Protection Criteria.](#)

[LEAK 2.4 Leak Management: Leak Surveys](#)

[LEAK 2.6 Leak Management: Leak Surveys - Walking Leak Survey](#)

[SERV 1 Service Line Installation: Requirements](#)

Document Rescission

SERV 2.05 Service Installation: Inactive Service, January 1, 2011.

Revision Notes

Location of Changes	Summary of Changes
Not applicable.	This is a new document.

SERVICE LINE INSTALLATION

October 1, 2021

SERV 2.6 Insertion

1.0 Purpose

The purpose of this document is to provide procedures for gas service line insertions.

2.0 Scope

This document addresses the following:

[3.0 Target Audience](#)[4.0 General Requirements](#)[5.0 Tracer Wire Installation](#)[6.0 Dead Service Line Insertion Procedures](#)[7.0 Conduit or Sleeve Insertion Procedures](#)

3.0 Target Audience

- Gas Engineering
- Gas Distribution Design Specialists
- Gas Field personnel
- Gas Construction personnel
- Gas Supervisors
- Gas Construction Services personnel

4.0 General Requirements

4.1 Supervisory approval is required for use of PE service line insertion.

Consideration should be given to the added difficulty of leak detection on inserted PE service line as well as the increased difficulty of locating a buried inserted line.

4.2 PE services lines may be inserted individually or as a part of a replacement project.

4.3 Inserted PE service lines shall meet all of the requirements of a new service. See [SERV 1](#) Service Line Installation: Requirements.

4.3.1 Existing services shall meet the depth requirements as outlined in [SERV 1](#) at the locations where the inserted pipe enters and exits the casing, conduit or sleeve.

4.3.2 For any entry and exit locations that do not meet the depth requirements of [SERV 1](#), a new location should be found to enter and exit the casing or the new service shall not be inserted.

4.4 Installing a larger PE carrier service pipe, than needed, in the old steel service line minimizes the possibility of the PE service line being squeezed by freezing. See [Table 1](#) for recommended casing sizes.

Water expands by approximately 9-10 percent as it freezes.

UNCONTROLLED IF PRINTED

Table 1

Recommended Maximum Casing Size for Inserted Services	
Inserted Service Size	Maximum Casing Size
1/2" CTS	1-1/4" IPS
1" CTS	2" IPS
1-1/4" IPS	3" IPS
2" IPS	4" IPS

The casing should be a least two nominal pipe sizes large than the service line pipe to ease insertion of the service line pipe.

- 4.5 Link seals shall be used to prevent water from entering the casing pipe, if the proper sizes are available. See [STLP 2.2](#) Casing Pipe Installation
- 4.6 The casing pipe should be inspected at each opening for debris or damage that may damage the carrier pipe during the insertion.

5.0 Tracer Wire Installation

- 5.1 A 12 gauge solid copper tracer (Stock Code 18 66 208/18 66 369) wire should be pulled through the old service line with the new pipe if possible. If there is not adequate space for 12 gauge wire, a 14 gauge solid copper tracer wire (Stock Code 18 66 677) may be used.
- 5.2 Casing size or configuration that do not allow a tracer wire to be pulled through the casing with the new service, shall use one of the following for tracer wire installation:
 - 5.2.1 Steel main with PE service inserted into a coated steel service line:

Bond connections shall be done prior to inserting PE pipe.

1. Bond tracer wire to the steel main at the service tap. See [Figure 1](#).
2. Bond to both ends of the casing and terminate above grade at the new riser. See [Figure 1](#).
3. See [CORR 2.8 Appendix B](#) Test Lead Wire Attachment for attachment procedures for the bond connection on the steel pipe. Cold applied tape or wax tape should be used to coat the connections.

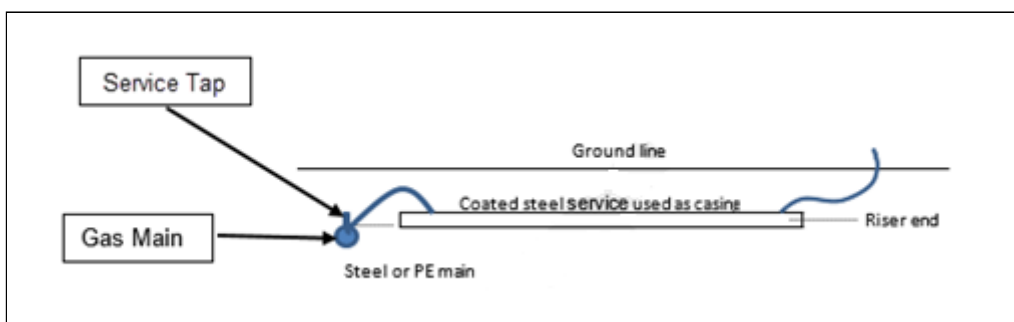

Figure 1. Bonding to Casing

5.2.2 Steel main with a PE service inserted into a bare steel pipe:

1. This may also be used as an option with a PE main or a coated steel service.
2. Install a five (5) pound anode near the service tap location on the service side of the main and attach it to the tracer wire for the inserted service. See Figure 2.

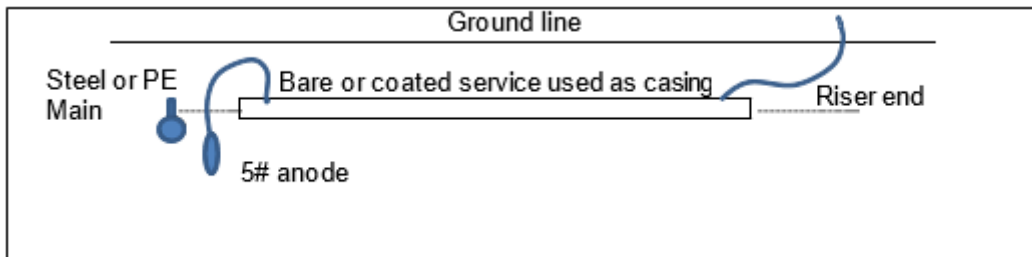

Figure 2. Anode Installation for Casing

Bond connections shall be done prior to inserting PE pipe.

3. Do not bond tracer wire to the steel main or tracer wire of the PE main.
4. Bond the tracer wire to both ends of the casing and terminate above grade at the new riser.
5. An optional test station may also be brought up to ground level at the tap location to aid in locating the main.
6. See [CORR 2.8 Appendix B](#) Test Lead Wire Attachment for attachment procedures for the bond connection on the steel pipe. Cold applied tape or wax tape should be used to coat the connections.

5.2.3 PE main with PE service inserted into a coated steel service line:

1. Connect the service line tracer wire to the tracer wire of the PE main at the service tap. See [Figure 3](#).
2. Bond connections shall be done prior to inserting PE pipe.
3. Bond to both ends of the casing and terminate above grade at the new riser.
4. See [CORR 2.8 Appendix B](#) Test Lead Wire Attachment for attachment procedures for the bond connection on the steel pipe. Cold applied tape or wax tape shall be used to coat the connections.

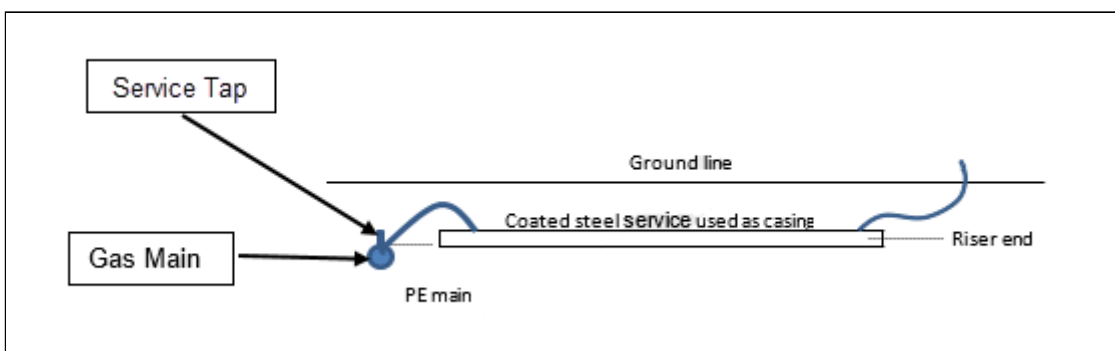

UNCONTROLLED IF PRINTED

Figure 3. Bonding to Casing and PE main.

6.0 Dead Service Line Insertion Procedures

- 6.1 Excavate the main at the service tap location.
- 6.2 Excavate:
 - 6.2.1 Service riser if the meter is outside
 - 6.2.2 Proposed riser location if the meter is to be moved outsideOr
 - 6.2.3 The location where the new service line will tie in the existing service line going into the building.

The service tee, valve, line stopper or squeeze off can be used to temporarily shut off the gas supply.

- 6.3 Shut off gas at the main.
- 6.4 Remove a section of the existing service line close to the main.
 - 6.4.1 Provide adequate clearance for inserting the new pipe and connecting to service tee, i.e. EFV and transition fitting if required.
- 6.5 Disconnect the piping at the customer end of the service and remove pipe as necessary.

Adequate space should be provided for the installation of new facilities.

- 6.6 Purge the abandoned section of pipe according to [ABND 2.1](#) Abandonment of Gas Facilities and [PURG 2](#) Purging: Methods.
- 6.7 Inspect all open ends of the casing pipe.
- 6.8 Ream any open ends of the casing pipe with a pipe reamer or file to remove sharp edges. All steel casings should be reamed.
- 6.9 PE pipe shall be protected at the entry openings of the casing pipe during insertion. See Table 2 for a list of available pipe protectors.

Table 2. Plastic Pipe Protectors

Plastic Pipe Protectors	
Size	Stock Code
3/4" x 1/2"	19 65 205
1-1/4" x 1/2"	19 65 207
1-1/4" x 1"	19 65 206



- 6.9.1 Place PE pipe protectors or other protective material in between the casing and the carrier pipe at locations where the inserted pipe enters or exits the casing.
- 6.9.2 Wrap the ends of the insertion and the plastic pipe protectors with tape to hold them in place. If using an insertion shrink sleeve, pull the sleeve over the pipe at this point instead of wrapping the ends.
- 6.10 Lay out the new PE service line as straight as possible in order to reduce the drag inside the old service line
- 6.11 When inserting larger PE pipe in larger casing, appropriate means shall be used to protect the carrier pipe from damage, such as but not limited to:
 - 6.11.1 Rock guard
 - 6.11.2 Plastic sleeves, etc.
- 6.12 If using an insertion shrink sleeve, place the sleeve on the casing prior to insertion. See Table 3 for a list of available shrink sleeves.

Table 3. Shrink Sleeves

Insertion Shrink Sleeves			
Steel Casing Pipe Size	PE Pipe Size	Stock Code	3M Product Number
3/4" IPS	1/2" CTS	19 35 280	PS - 2
1" IPS	1/2" CTS	19 35 280	PS - 2
1-1/4" IPS	1/2" CTS	19 35 281	PS - 3
1-1/4" IPS	1" CTS	19 35 281	PS - 3



- 6.13 Seal the leading end of the pipe being inserted to keep out dirt, debris or water.
- 6.14 If the inserted PE pipe is being pulled through the casing pipe, a weak link shall be used. Refer to [POLY 2.3 Section 10.0](#) Weak Link.
- 6.15 Insert the PE pipe through the casing pipe.
- 6.16 After insertion is complete, inspect the leading edge of PE pipe for damage.
 - 6.16.1 If the pipe is damaged, remove and discard the damaged pipe then repeat steps [6.8](#) through 6.13.
 - 6.16.2 If another attempt is unsuccessful abandon old service, casing. See [ABND 2.1](#) Abandonment of Gas Facilities.
 - 6.16.3 Install a new service line.
- 6.17 The steel service riser for an existing outside meter shall be removed and should not be used during the insertion.
- 6.18 The steel riser should be cut off at a distance from the building that would allow adequate space for a new anodeless riser to be installed. See [SERV 1](#) for meter location requirements.
- 6.19 Connect the inserted pipe to the new service riser with an approved connection. See [POLY 2.5](#) Electrofusion.
- 6.20 If the existing service line enters the building below grade, the preferred method for terminating the inserted PE service line is to install anodeless riser outside the foundation wall.

At a minimum, meter valve and service regulator should be installed on the riser. See [SERV 1](#) for meter location requirements.

- 6.21 If the preferred method is not possible, the following option may be utilized:
 - 6.21.1 PE service line can be installed through the outer foundation provided that the plastic service is inserted inside of piping material permitted for use in buildings and an indoor service head adapter is used to seal against the possibility of gas

entering the structure. See Table 4 for a list of available Indoor Service Head Adapter.

Table 4. Service Head Adapter

Indoor Service Head Adapters		
Size (Casing x Service)	Outlet	Stock Code
1-1/4" x 1"	1-1/2" MNPT	19 33 686
3/4" x 1/2"	1" MNPT	19 33 687



6.21.2 The least desirable option is connecting the service line to a transition fitting installed immediately outside the foundation using approved connections. [POLY 2.4](#) Butt Fusion or [POLY 2.5](#) Electrofusion and [WELD 2.4](#) In-Service Welding.

1. This option shall be considered as a last resort

This option leaves an isolated section of steel through the foundation wall which will require scheduled CP monitoring and compliance.

2. The Gas Supervisor shall consult with Corrosion Control personnel prior to installation.
3. Corrosion Control personnel shall determine the appropriate measures to be taken in order to monitor CP on the isolated section.
4. The location shall be recorded as an Isolated Service and added to the appropriate CP monitoring schedule.

6.21.3 Regardless of which method is used, a readily accessible valve shall be installed in the service line outside of the foundation. See [SERV 1](#).

6.21.4 If the existing service tee does not meet the current Standards, then a new tee shall be installed and the existing tee retired. See [ABND 2.1](#) Abandonment of Gas Facilities.

Examples of service tees not meeting standard are:

UNCONTROLLED IF PRINTED

1. Homemade tees
2. Tees without the internal parts
3. Tees that cannot be shut-off

6.21.5 If using a new service tee the service tee should be connected to the main and service line using an approved fusion or welding procedure. See [POLY 2.4](#) Butt Fusion or [POLY 2.5](#) Electrofusion or [WELD 4](#).

1. If a new service tee and/or new service line is installed, see [SERV 1](#) and [SERV 2.2](#) for EFV requirements.
2. Pressure test the service as required in [PTST 1](#) prior to tapping the service tee.

6.21.6 If using the existing service tee:

1. Pressure test the service line prior to connecting the service line to the existing service tee. See [PTST 1.1 Table A](#).
2. Refer to [SERV 2.2](#) for EFV requirements.
3. Connect the service line to the service tee using an approved fusion or welding method. See [POLY 2.5](#) Electrofusion and [WELD 4](#).
4. Introduce gas to the new service line and test the tie-in to the existing service tee with leak detection solution or leak detection instrument.

6.22 Rebuild the meter set as necessary.

6.23 Backfill as required in [SERV 1](#).

6.24 Records for the inserted PE service shall indicate that the service is inserted.

7.0 Conduit or Sleeve Insertion Procedures

- 7.1 Locate and excavate each end of the conduit or sleeve. The conduit or sleeve should meet the depth requirements as outlined in [SERV 1](#).
- 7.2 Inspect the conduit/sleeve for damage or debris that may damage the inserted pipe during installation.
- 7.3 If the conduit/sleeve needs to be shortened for any reason, it should be inspected again prior to the insertion.
- 7.4 Ream any open ends of the steel conduit/sleeve with a pipe reamer or file to remove sharp edges as necessary.
- 7.5 Place plastic pipe protectors at all openings where the inserted pipe will be entering and exiting the steel conduit/sleeve during the insertion, if the proper sizes are available. See [Section 6.9](#).

A short section of pipe may be pulled through as a dry run to minimize the risk of damage occurring to the actual carrier pipe during the installation. If the dry run pipe is damaged inspect the conduit again and take measures as necessary to prevent damage to the inserted pipe.

- 7.6 Seal the leading end of pipe being inserted to keep out dirt, debris, or water.
- 7.7 Insert the carrier pipe through the conduit or sleeve. Tracer wire shall be installed with PE carrier pipe.
- 7.8 After insertion is complete, inspect the leading edge of carrier pipe for damage. If the pipe is damaged, remove the inserted pipe and repeat steps [7.2](#) through 7.7.

Do not reuse any damaged pipe from a previous insertion attempt.

- 7.8.1 If a steel pipe is the carrier pipe and damage is limited to the coating on the leading end, coating can be repaired in accordance with [CORR 2.3 Appendix K](#) Coating Inspection.
- 7.8.2 If the leading end of the steel carrier pipe is gouged it shall be evaluated and repaired in accordance with [REPR 1](#).
- 7.8.3 If the damaged coating or pipe extends into the conduit or sleeve:
 - 1. Remove a sufficient length that coating and/or pipe damage can be repaired
 - Or
 - 2. Remove the entire section of pipe.
 - Then
 - 3. Evaluated the extent and nature of the damage to determine if the conduit/sleeve can be used or if the conduit/sleeve should be abandoned.
- 7.9 Seal both ends of the carrier pipe until it is tied into the remainder of the new service line to prevent water or debris from entering the pipe.
- 7.10 Pressure test the service as required in [PTST 1](#) prior to tying the inserted pipe into an existing service line.
- 7.11 Tie into the existing service line using approved connections and fittings. See [POLY 2.4](#) Butt Fusion or [POLY 2.5](#) Electrofusion.
- 7.12 Leak test the tie in connection at normal operating pressure with leak detection fluid.
- 7.13 Backfill as required in [SERV 1](#).
- 7.14 Records for the service shall indicate that the service is inserted through a conduit or sleeve.

End of Instructions.

Operator Qualification (OQ) Required?

YES.

0041: Installation and Maintenance of Mechanical Electrical Connections

0051: Installation of Exothermic Electrical Connections

0061: Inspect or Test Cathodic Protection Bonds

0201: Visual Inspection of Installed Pipe and Components for Mechanical Damage

UNCONTROLLED IF PRINTED

0211: Measure and Characterize Mechanical Damage on Installed Pipe and Components

0301: Manually Opening and Closing Valves

0561: Pressure Test - Nonliquid Medium- MAOP Less than 100 Psi

0571: Pressure Test - Nonliquid Medium- MAOP Greater than or Equal to 100 Psi

0591: Leak Test at Operating Pressure

0641: Visually Inspect Pipe and Components Prior to Installation

0681: Joining of Plastic Pipe - Stab Fittings

0751: Joining of Plastic Pipe - Butt Heat Fusion: Manual

0761: Joining of Plastic Pipe - Butt Heat Fusion: Hydraulic Machine

0781: Joining of Plastic Pipe - Electrofusion

0801: Welding

0811: Visual Inspection of Welding and Welds

0861: Installation of Steel Pipe in a Ditch

0901: Installation of Plastic Pipe in a Ditch

0941: Install Tracer Wire

0951: Installation of Pipe Above Ground

0971: Installation and Maintenance of Casing Spacers, Vents and Seals

0981: Backfilling

0991: Coating Application and Repair - Brushed or Rolled

1001: Coating Application and Repair - Sprayed

1011: External Coating Application and Repair - Wrapped

1081: Tapping a Pipeline (Tap Diameter 2 Inch or Less)

1091: Tapping a Pipeline (Tap Diameter Greater Than 2 Inch)

1101: Tapping a Pipeline with a Built-In Cutter

1131: Stopper (Stopper) Pipe

1141: Squeeze Off Plastic Pipe

1161: Installation of Customer Meters and Regulators - Residential and Small Commercial

1191: Maintenance of Service Valves Upstream of Customer Meter

1201: Temporary Isolation of Service Lines and Service Discontinuance

1291: Locate Underground Pipelines

A001: Service Reconnect

Appendices

NONE.

Attachments

NONE.

Compliance Requirements

49 CFR §192.361 Service lines: Installation.

Reference Documents

[ABND 2.1 Abandonment of Facilities: Abandonment of Gas Facilities](#)

[CORR 2.3 Corrosion Control: Coatings](#)

[CORR 2.8 Corrosion Control: Cathodic Protection Testing](#)

[POLY 2.4 Polyethylene Pipe: Butt Fusion](#)

[POLY 2.5 Polyethylene Pipe: Electrofusion](#)

[PTST 1 Pressure Testing: Requirements](#)

[PURG 2 Purging: Methods](#)

[REPR 1 Repairs: Requirements](#)

[SERV 1 Service Line Installation: Requirements](#)

[STLP 2.1 Steel Pipe: Casing Pipe Installation](#)

[WELD 2.4 Welding: In-Service Welding](#)

Document Rescission

SERV 2.08 Service Line Installation: Insertion, October 1, 2020.

Revision Notes

Location of Changes	Summary of Changes
Subsection 6.10	New – Lay out the new PE service line as straight as possible in order to reduce drag inside the old steel service line.
Subsection 6.14	New – If the inserted PE pipe is being pulled through the casing pipe, a weak link shall be used. Refer to POLY 2.3 Section 10.0 Weak Link.

SERVICE LINE INSTALLATION

October 1, 2022

SERV 2.7 Gas Service Card Form and Gas Sketch Card

1.0 Purpose

The purpose of this document is to provide instructions for completing the Gas Service Card Form within ClickMobile and Gas Sketch Card, which contain information to comply with 49 CFR §§ 191.11 and 192.383.

2.0 Scope

This document addresses the following:

[3.0 Target Audience](#)

[4.0 Gas Service Card Form](#)

[5.0 Service Sketches](#)

[6.0 Gas Sketch Card Completion Instructions](#)

[7.0 Distribution - Gas Sketch Card](#)

Appendices:

[Appendix A - Sample - Gas Sketch Card](#)

3.0 Target Audience

- Gas Field Personnel
- Gas Supervisors
- Gas Construction Services Personnel

4.0 Gas Service Card Form (49 CFR§191.11, 49 CFR§192.383)

- 4.1 The Gas Service Card Form shall be completed within ClickMobile by gas field personnel:
- 4.2 The following list identifies the most common instances when a Gas Service Card Form should be completed by gas field personnel.
- 4.2.1 **New Installation** of gas service line.
- 4.2.2 **Replacement** of a gas service – total or partial
- 4.2.3 **Extension** of a gas service
- 4.2.4 **Repair** of a gas service by installing a fitting or a new pipe section
- 4.2.5 **Retirement** of a gas service
- 4.3 Some of the information on the card is required to comply with 49 CFR §§ 191.11 and 192.383.
- 4.3.1 AIC must annually report to PHMSA, the number of services installed and retired.
- 4.3.2 EFV or manual service line shut-off valve installations measures shall be included in the annual report to PHMSA.
- 4.4 GIS Discrepancy in ClickMobile is used to correct existing service attributes such as:

UNCONTROLLED IF PRINTED

4.4.1 Pipe size.

4.4.2 Pipe material.

4.4.3 Connection to the correct gas main.

4.5 This information may also be used by Operations, Engineering, Corrosion Control and DIMP for future design, maintenance or risk analysis.

5.0 Service Sketches

5.1 Service Sketch shall be completed within ClickMobile to record and/or clarify work for all service installations that are:

5.1.1 New

5.1.2 Replaced - total or partial.

5.1.3 Relocated

5.1.4 Extended existing service line

5.1.5 Repaired when new section of pipe is installed

5.1.6 Partially retired when 18 inches or longer of existing pipe remains connected to source of gas.

5.2 The following information shall be provided in ClickMobile:

5.2.1 Address if the service - required field

5.2.2 City or town - system populates

5.2.3 Premise Number - required field

5.2.4 DOJM Number - required field in P1/open field in P3

5.2.5 Name of the person responsible for performing the work - system populated

5.2.6 Employee Number of the person responsible for performing the work - system populated

5.2.7 Contractor Company if an outside contractor performed the work - Enter

5.2.8 Date the work was performed - system generated/required if modification is needed

5.2.9 Remarks - Enter if needed

5.2.10 Measurement indicating the overall service length shall be included on the sketch.

5.2.11 A minimum of two measurements from the service tee to the other points of reference shall be included on the sketch.

1. Acceptable points of reference include:

1a. Corner of a house or permanent building.

1b. Centerline (CL) of the street and/or the nearest cross street.

1c. Edge of pavement (EOP) or curblineline (CB) for the street/nearest cross street.

1d. Sewer man hole covers (MH) and storm sewer drain (SD).

UNCONTROLLED IF PRINTED

- 1e. Fire hydrant (FH).
- 1f. Utility pedestal (Ped) or electric transformer (PM). If pedestal or transformer has visible identification number, please notate that on the sketch or in the remarks.
- 1g. Edge of driveway or sidewalk.
- 1h. Include text on the sketch to indicate what point of reference is being used.
- 1i. It is acceptable to write out the measurements in words in the remarks section of the sketch. ([See Example 2](#))

In lieu of a sketch being made in ClickMobile, the sketch can be made on a copy of the Service Sketch Card then scanned and attached to the Work Order task assigned.

The sketch should include the information listed in 5.2.10 and 5.2.11 at a minimum.

Example 1

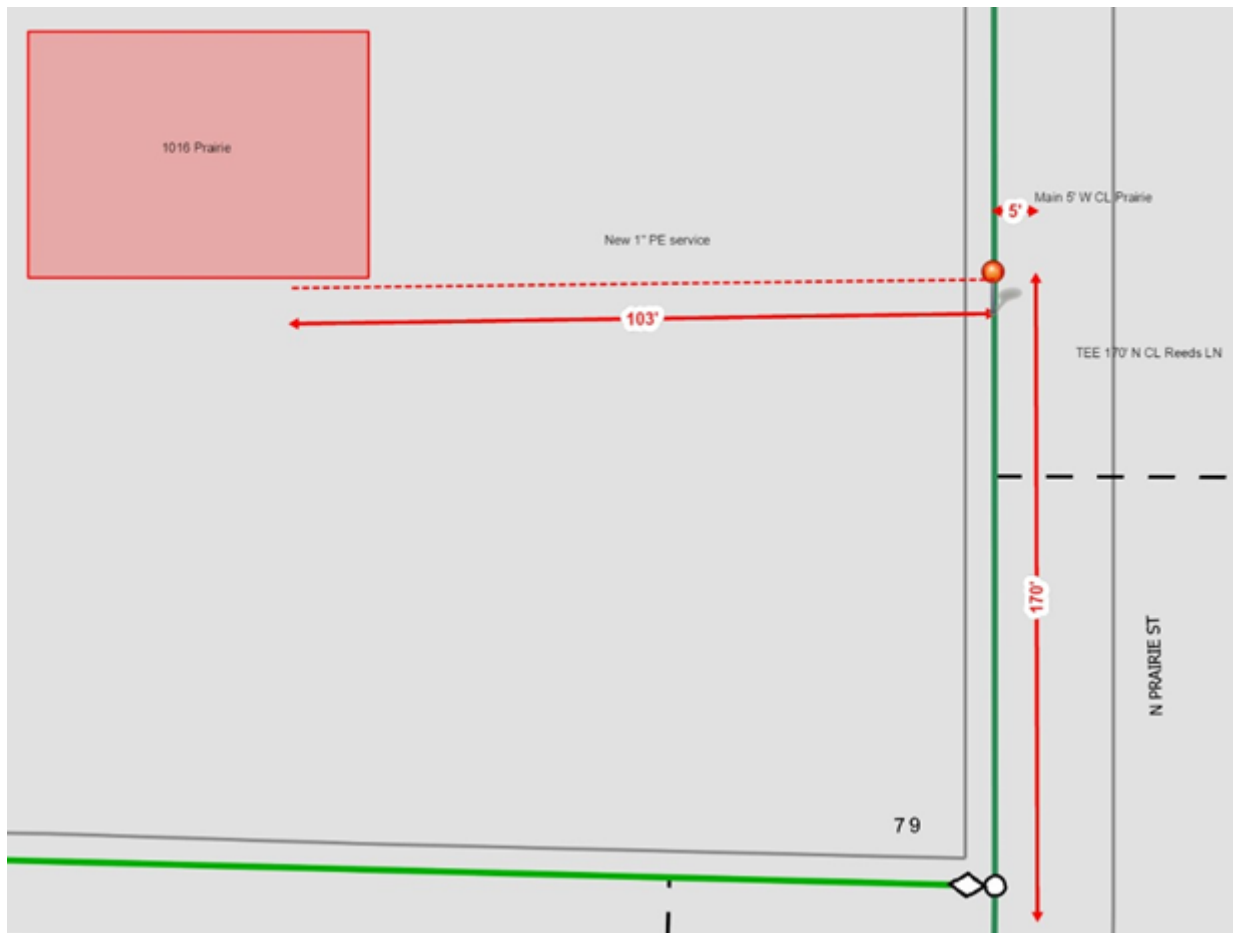

Example 2

UNCONTROLLED IF PRINTED

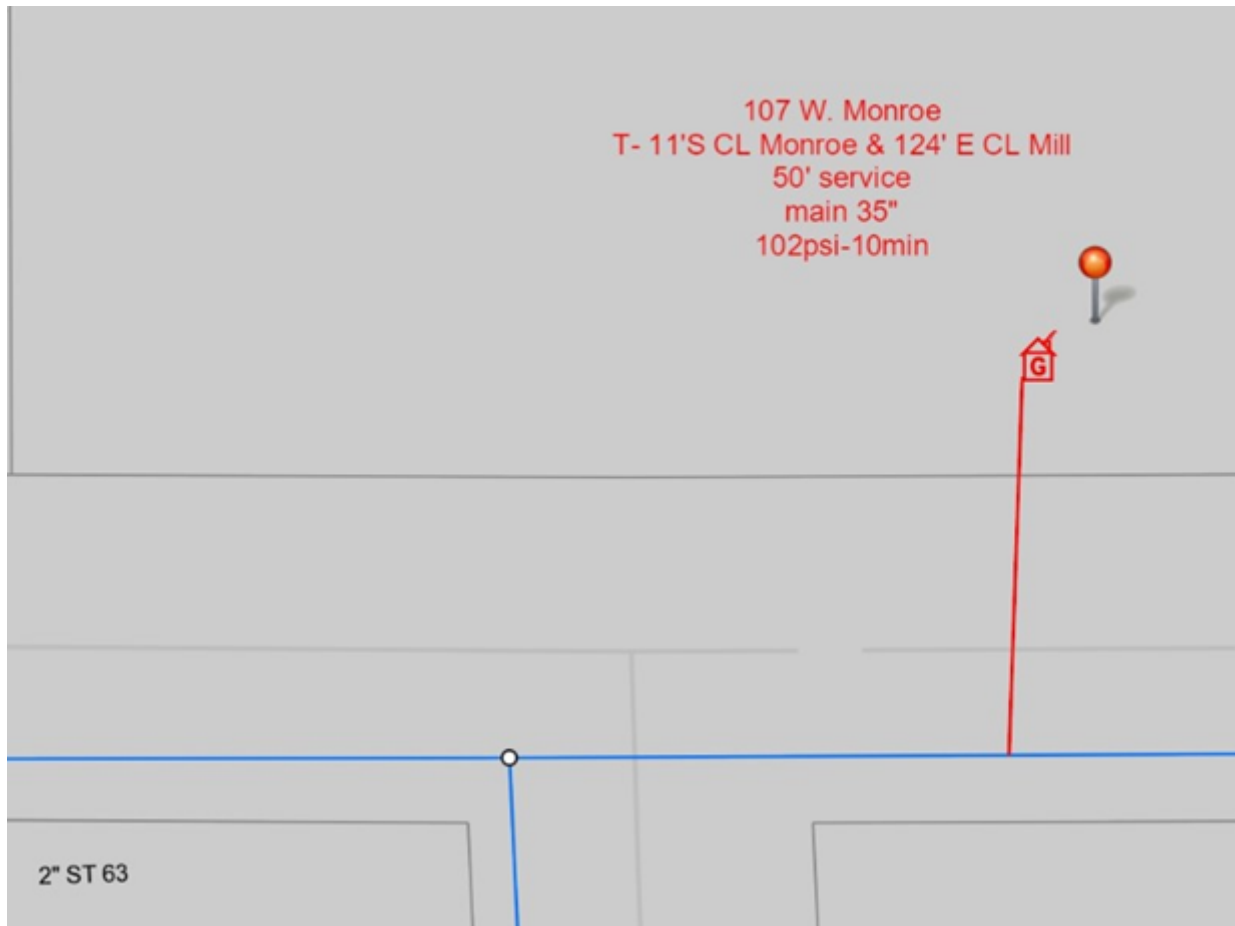

6.0 Gas Sketch Card Completion Instructions

- 6.1 The ClickMobile Gas Service Form contains required fields that must be accurately completed.

It is good practice to record all information that is known about the service.

- 6.2 If a hand drawn sketch is being used for the service sketch, the information listed in [Subsection 5.0](#) Service Sketches Service Sketches, shall be included on the sketch.

7.0 Distribution - Gas Sketch Card

- 7.1 An email will be sent the appropriate poster who will access Maximo and retrieve the Service Request task and Service Sketch.
- 7.2 The poster will post a service in AIC's electronic mapping system when necessary and maintain the Maximo Service Asset number for the service in ESRI.
- 7.3 The Gas Service Card Form information will be maintained in Maximo.

End of Instructions.

Operator Qualification (OQ) Required?

UNCONTROLLED IF PRINTED

NO.

Appendices

NONE.

Attachments

NONE.

Compliance Requirements

49 CFR §191.11 Distribution system: Annual report.

49 CFR §192.383 Excess flow valve installation.

Reference Documents

NONE.

Document Rescission

SERV 2.7 Service Line Installation Gas Service Card Form and Gas Sketch, May 15, 2022

Revision Notes

Location of Changes	Summary of Changes
Paragraph 5.1.6 – Service Sketch	Grammatical – Partially retired when 18 inches or longer of existing pipe remains connected to source of gas.
Subsection 5.2	Revised – The following information shall be provided in Click-Mobile. Information is not required on sketch.
Paragraph 5.2.1 through 5.2.9	Indicated what information is required and which is system populated.
Subsection 5.2 – NOTE:	Added reference to what information is required on a hand drawn sketch that is being attached to the Work Order.
Appendix A	Added Information listed below should be entered within Click-Mobile.

Appendix A, Sample - Gas Sketch Card

Ameren ILLINOIS Service Sketch Card

Address: _____ (1)
City: _____ (2)
Premise#: _____ (3)
DOJM#: _____ (4)
Name: _____ (5)
Empl#: _____ (6)
Date: _____ (8)
Contractor Company (if applicable):
_____ (7)
Remarks: _____ (9)

Indicate Direction With Arrow

ROW

ROW

Stock No. 374-1375 F5850

10/16

Note: Sketch shall follow the instructions in Paragraph 5.2.10 and Paragraph 5.2.11

Key: Information listed below should be entered within ClickMobile.

1. Address of the service
2. City or town
3. Premise Number
4. DOJM Number
5. Name of the person responsible for performing the work
6. Employee Number of the responsible person performing the work
7. Contractor Company, if an outside contractor performed the work
8. Date the work was performed
9. Remarks

SERVICE LINE INSTALLATION

October 1, 2020

SERV 2.8 Gas Service GTech Mapping

1.0 Purpose

The purpose of this document is to provide instruction for mapping Gas premises, gas service lines, and meters in G/Tech.

2.0 Scope

This document addresses the following:

[3.0 Target Audience](#)

[4.0 Mapping - General](#)

[5.0 Mapping a Premise](#)

[6.0 Mapping Meter Points](#)

[7.0 Mapping a Gas Service](#)

[8.0 Mapping a Farm Tap Service](#)

[9.0 Mapping a Branch Service](#)

[10.0 Mapping a Replaced Service](#)

[11.0 Mapping a Retired Service](#)

[12.0 Mapping a Stub Service](#)

[13.0 Mapping a Transferred Service](#)

3.0 Target Audience

- Gas Distribution Design - Posters
- Gas Engineering
- Gas Field Engineering Representatives

4.0 Mapping - General

- 4.1 All gas premises and new gas service lines shall be symbolically mapped in G/Tech.
- 4.2 Service attributes are collected on a Gas Service Card Form within ClickMobile and retained in Maximo. Refer to [SERV 2.7](#) Service Line Installations: Gas Service Card Form and Gas Sketch Card.

Maximo maintains the official service attributes record and gas service drawing.

- 4.3 G/Tech will maintain the relationship between the Customer Service System (CSS) Service Drop number and the Maximo Asset number.

5.0 Mapping a Premise

UNCONTROLLED IF PRINTED



- 5.1 Place premise symbol () represents a gas premise.
- 5.2 The peak of the house in the premise symbol will point north. It is not necessary to rotate the symbol.

The Gas Service Card Form drawing will portray the premise's actual location and direction.

- 5.3 The premise symbol shall be located in the middle of the lot unless more location information is known.
- 5.4 The house number should be perpendicular to the centerline of the street and on the far side of the premise symbol from the main. See Figure 1.

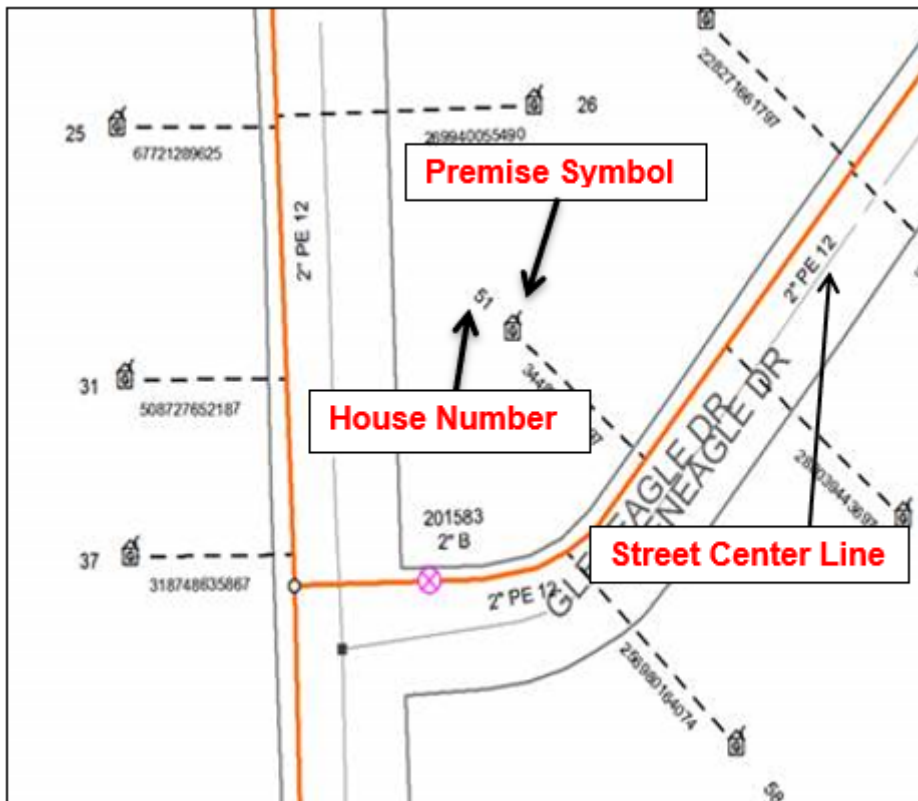

Figure 1. House number location

- 5.5 The house number and unit/apartment number shall be shown for the premise, if applicable.
- 5.6 The premise symbols for two or more premises served from one service pipe (not a branch service) shall be mapped at one location as follows:
 - 5.6.1 Place the premise symbols on top of one another. See Figure 2.
 - 5.6.2 All house numbers should be listed next to the premise symbol. See Figure 2.

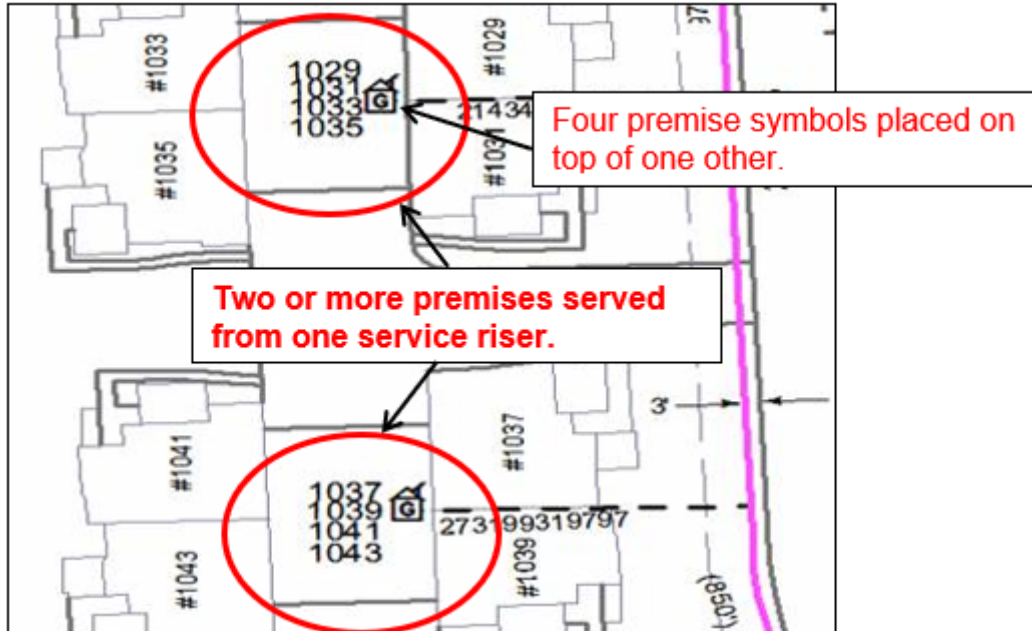

Figure 2. Premises on top of one another

6.0 Mapping Meter Points

- 6.1 Each active gas meter point shall be associated as an attribute of a premise in G/Tech.
- 6.2 Each active gas meter point shall be associated to the main it is served from.

7.0 Mapping a Gas Service

- 7.1 Gas service and their ownership to a main are maintained in G/Tech.
- 7.2 Gas service attributes are maintained in Maximo.
- 7.3 All new gas services shall be mapped in G/Tech.
- 7.4 The graphical representation of a service line is not the physical path to the premise.

The physical path, dimensions, material, and other service attributes are captured on the Gas Service Card Form. Refer to [SERV 2.7](#) Service Line Installation: Gas Service Card Form and Gas Sketch Card.

- 7.5 Service line should be drawn from the appropriate main to the center of the premise symbol. See Figure 3 for examples.

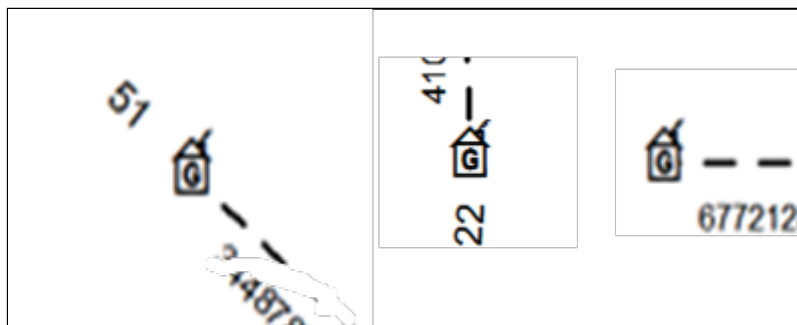



Figure 3

- 7.6 Service line shall be mapped at the appropriate location in relation to main valve, fittings, tees, etc.
- 7.7 Service line shall show ownership (relationship) to the correct main.
- 7.8 For service lines being mapped, the correct CSS Service Drop number and the correct Maximo Service Asset number should be associated to the service.
- 7.9 Excess flow valves, curb valves, valve tees, and other fittings should not be mapped in G/Tech.

The gas fitting information is maintained in Maximo.

8.0 Mapping a Farm Tap Service

The physical path, dimensions, material, and other service attributes are captured on the Gas Service Sketch within Click Mobile.

- 8.1 The entire service line from the main to the premise will be posted as one graphic service line and follow gas service mapping. Refer to [Section 7.0](#).
- 8.2 A Farm Tap symbol () will be placed on the service line as close as practical to the actual location in the field.
- 8.3 Farm taps shall be associated to both the gas main and the gas service.
- 8.4 Ownership shall be established from the farm tap to the main.
- 8.5 Any gas service with a farm tap that is served from a high pressure distribution or transmission main must be owned by a farm tap and a main.

If service line operates at line pressure with no farm tap, special posting is required.

- 8.6 Gas service(s) placed and served from a farm tap will need a structure ownership established to a farm tap and gas ownership established to a main.
- 8.7 The gas service is considered a “Child” to the “Parent” farm tap and main. See Figure 4.

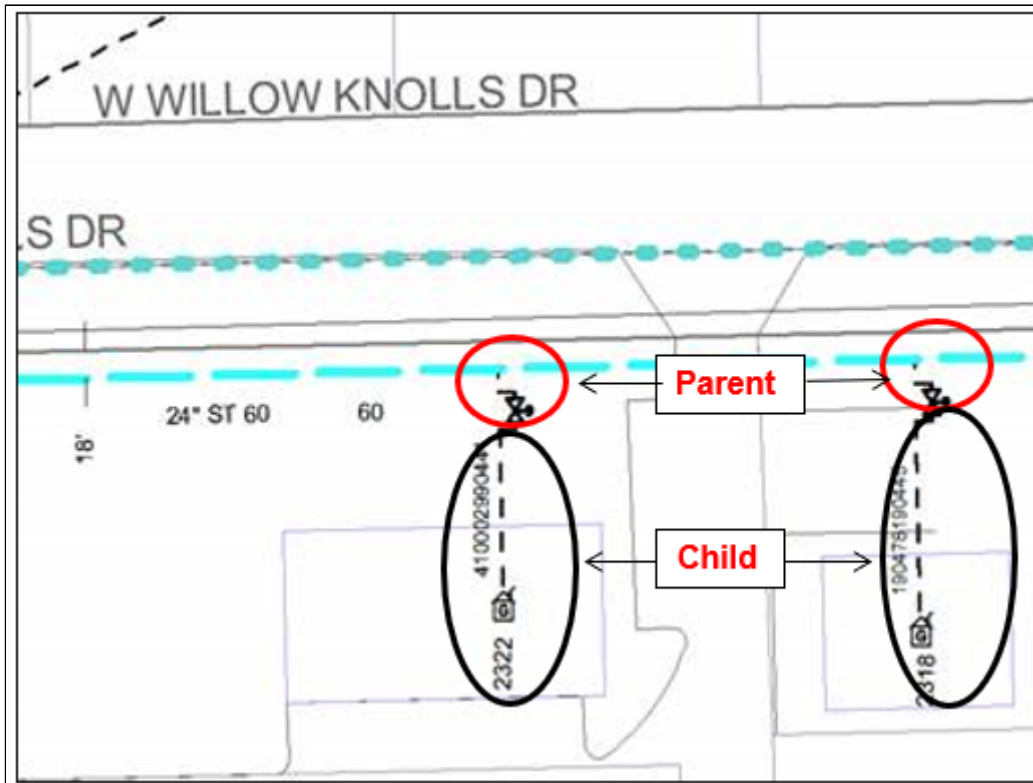

Figure 4. Child and Parent illustration

9.0 Mapping a Branch Service

- 9.1 Each section of a branch service shall be associated to the main servicing it.
- 9.2 Branch services should be graphically drawn to accurately represent its point of origin, off of the existing or primary service line, to its premise.
- 9.3 Care should be taken to assign the proper Service Drop number and Maximo Service Asset number to the correct service segment. See Figure 5.

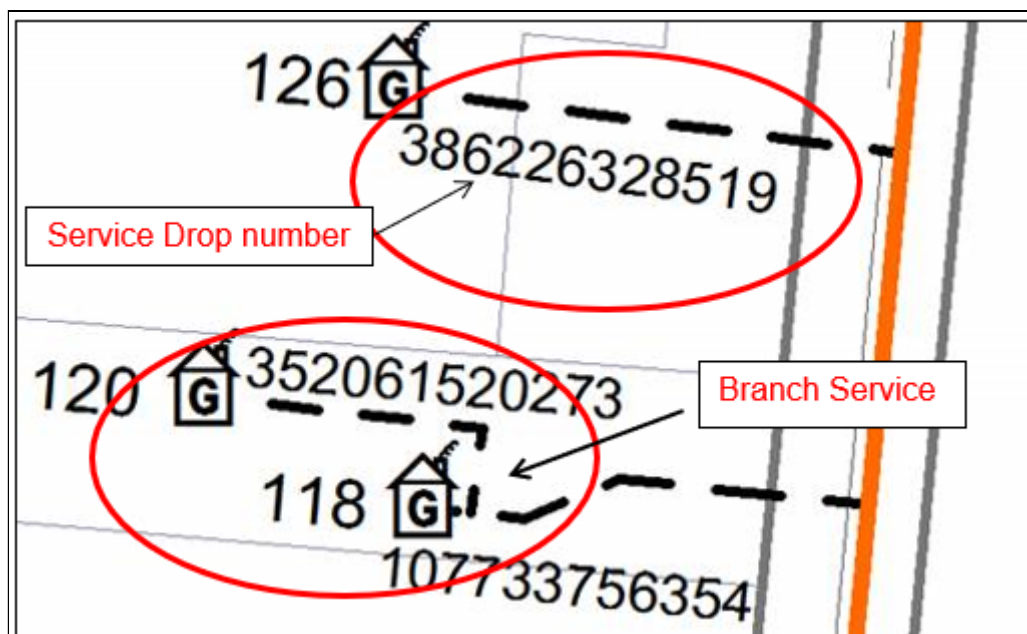

Figure 5. Service Drop Number

10.0 Mapping a Replaced Service

10.1 If a service that has previously been mapped in G/Tech is replaced, no mapping changes are required in G/Tech.

10.2 If the replaced service is being attached to a new or different main a mapping change is required. See [Section 13.0](#).

10.3 If a service is replaced that has not been mapped in G/Tech. follow the steps for mapping a new gas service.

11.0 Mapping a Retired Service

11.1 A service that has been retired will be mapped as an abandoned service.

11.2 Maximo will maintain the attributes and retirement date for the retire service.

11.3 The Service Drop number and Maximo Service Asset number shall stay with the retired service to maintain relationship to the service attribute record in Maximo.

12.0 Mapping a Stub Service

12.1 Each stub service shall be mapped according to [ABND 2.1](#).

12.2 An existing service drop number and Maximo Service Asset number should remain associated with the stub service.

This will allow a reference for tapping information, location dimensions and material records.

12.3 If no service drop number exists for the stub service, then enter zero, "0", for the service drop number.

13.0 Mapping a Transferred Service

13.1 When the service connection changes to a different main, the ownership of the service shall be changed to the new main.

13.2 When the service connection changes to a different main, the gas meter point association on the premise attribute shall be corrected to the new main.

End of Instructions.

Operator Qualification (OQ) Required?

NO.

Appendices

NONE.

Attachments

NONE.

Compliance Requirements

NONE.

Reference Documents

UNCONTROLLED IF PRINTED

[ABND 2.1 Abandonment of Facilities: Abandonment of Gas Facilities](#)

[SERV 2.7 Service Line Installations: Gas Service Card Form and Gas Sketch Card](#)

Document Rescission

SERV 2.07 Service Line Installation: Gas Service G/Tech Mapping, January 1, 2016.

Revision Notes

Location of Changes	Summary of Changes
Not applicable.	This is a new document.

SERVICE LINE INSTALLATION

October 1, 2020

SERV 3 Forms and Reference Materials

Click on the links below to open the documents.

References

1. [Transmission Map – 20% SMYS MAOP](#)

End of Section.

Document Rescission

SERV 4 Service Line Installation: Forms and Reference Materials, October 15, 2018.

Revision Notes

Location of Changes	Summary of Changes
Not applicable.	This is a new document.

STLP-Steel Pipe

STEEL PIPE

October 1, 2022

STLP 0 Table of Contents

[STLP 1 Steel Pipe: Requirements](#)

Section 1.0 Purpose

Section 2.0 Scope

Section 3.0 Target Audience

Section 4.0 General

Section 5.0 Joining

Section 6.0 Bends and Elbows (49 CFR §192.313)

Section 7.0 Casing Requirements (49 CFR §192.323)

Section 8.0 Pipe Coating and Corrosion Control

Section 9.0 Damage During Construction

Section 10.0 Buried Pipe Examination

Section 11.0 Corrosion and Steel Damage Evaluation

Section 12.0 Pipe Thread Sealers

Operator Qualification

Compliance Requirements

Reference Documents

Document Rescission

[STLP 2.1 Steel Pipe: Casing Pipe Installation](#)

Section 1.0 Purpose

Section 2.0 Scope

Section 3.0 Target Audience

Section 4.0 General

Section 5.0 Casing Installation

Section 6.0 Link-Seal Installation

Section 7.0 Gel Filled Casing

Operator Qualification

Compliance Requirements

Reference Documents

UNCONTROLLED IF PRINTED

Document Rescission

STLP 2.2 Steel Pipe: Design Pressure

Section 1.0 Purpose

Section 2.0 Scope

Section 3.0 Target Audience

Section 4.0 Procedures

Operator Qualification

Appendices

Appendix A - Steel Pipe Stock Code Table

Compliance Requirements

Reference Documents

Document Rescission

STLP 2.3 Steel Pipe: Squeeze-Off

Section 1.0 Purpose

Section 2.0 Scope

Section 3.0 Target Audience

Section 4.0 Safety

Section 5.0 Preparation

Section 6.0 Squeeze-Off Operation

Section 7.0 Squeeze-Off Removal

STLP 3.1 Steel Pipe: Weld Fittings

Section 1.0 Purpose

Section 2.0 Scope

Section 3.0 Target Audience

Section 4.0 Weld Fittings (49 CFR §192.149)

Section 5.0 Weld Transition Fittings

Section 6.0 Weld End Insulators

Operator Qualification

Appendices

Appendix A - Elbows and Returns

Appendix B - Reducing Elbows

Appendix C - Tees

Appendix D - Reducing Tees and Concentric

Appendix E - Caps

UNCONTROLLED IF PRINTED

Appendix F - Unions

Appendix G - Quick Opening Closures

Appendix H - Weld Transition Fittings

Appendix I - Weld End Insulators

Compliance Requirements

Reference Documents

Document Rescission

STLP 3.2 Steel Pipe: Reinforcing Saddles

Section 1.0 Purpose

Section 2.0 Scope

Section 3.0 Target Audience

Section 4.0 General

Section 5.0 Installation

Operator Qualification

Appendices

Appendix A - Saddles

Appendix B - Shaped Nipple

Compliance Requirements

Reference Documents

Document Rescission

STLP 3.3 Steel Pipe: Flanges

Section 1.0 Purpose

Section 2.0 Scope

Section 3.0 Target Audience

Section 4.0 General

Section 5.0 Flange Assembly

Section 6.0 Tightening Sequence

Operator Qualification

Appendices

Appendix A - Weld Neck - Raised Face

Appendix B - Weld Neck - Flat Face

Appendix C - Screwed - Flat Face

Appendix D - Blind

Appendix E - Lap Joint

Appendix F - Flange Stud Bolts

UNCONTROLLED IF PRINTED

Appendix G - Gaskets

Compliance Requirements

Reference Documents

Document Rescission

STLP 4.0 Forms and Reference Materials

Reference Materials

Document Rescission

End Table of Contents.

Document Rescission

STLP 0 Steel Pipe – Table of Contents, October 1, 2020

Revision Notes

Location of Changes	Summary of Changes
STLP 2.3	New Section – Squeeze-off Steel Pipe
STLP 4	New Section – Forms and Reference Materials

STLP 1 Requirements

1.0 Purpose

The purpose of this document is to prescribe the requirements for installing steel pipe for transmission lines, high pressure distribution and distribution mains, and service lines in accordance with 49 CFR Part 192 Subpart B and Subpart C.

2.0 Scope

This document addresses the following:

[3.0 Target Audience](#)

[4.0 General](#)

[5.0 Joining](#)

[6.0 Bends and Elbows \(49 CFR §192.313\)](#)

[7.0 Casing Requirements \(49 CFR §192.323\)](#)

[8.0 Pipe Coating and Corrosion Control](#)

[9.0 Damage During Construction](#)

[10.0 Buried Pipe Examination](#)

[11.0 Corrosion and Steel Damage Evaluation](#)

[12.0 Pipe Thread Sealers](#)

3.0 Target Audience

- Gas Engineering
- Gas Tech Engineering (GTE)
- Gas Storage Engineering (GSE)
- Gas Field Personnel
- Gas Supervisors
- Gas Tech Services (GTS) Supervisors
- Gas Tech Services (GTS) Personnel
- Gas Storage Field Supervisors
- Gas Storage Field Operators
- Gas Construction Services Personnel
- Construction Inspectors

4.0 General

4.1 Steel Pipe Design

4.1.1 For steel pipe design and determination of design pressure, see [STLP 2.2](#).

4.1.2 For steel pipe stock code tables, see [STLP 2.2 Appendix A](#).

4.2 Steel Pipe Design Records (49 CFR §192.127)

4.2.1 For steel transmission pipelines, Ameren Illinois (AIC) shall maintain records which document the pipe design and design pressure for the life of pipeline.

4.2.2 For steel transmission pipelines installed on or before July 1, 2020, if AIC does not have the appropriate records to verify a pipeline's MAOP, a reconfirmation of the MAOP may be required.

4.2.3 GTE and Integrity Management will ensure the records are properly maintained and will make the determination of which transmission pipeline segments will require MAOP reconfirmation.

4.3 Material Identification and Verification

4.3.1 Steel pipe, coated or bare, shall have permanent markings in accordance with the specification in which it was manufactured and that are included in Ameren Illinois (AIC) steel pipe specifications. If these markings have faded and are no longer readable, the steel pipe shall not be installed.

4.3.2 Heat number is typically located on both ends of the pipe. If the section of pipe containing the heat number is removed, the heat number shall be manually transferred to the outside of the remaining pipe segment. A permanent marker shall be used to record the heat number.

4.3.3 Transmission pipelines shall have traceable, verifiable and complete records that document the physical characteristics of the pipe to include:

1. Pipe diameter,
2. Wall thickness,
3. Seam type,
4. Yield strength,
5. Ultimate tensile strength,
6. Chemical composition of pipe material.

4.3.4 Transmission pipeline records shall also include tests, inspections and attributes required by the manufacturing specifications at the time the pipe was manufactured or installed.

Chemical composition and other tests are recorded on the Mill Test Reports (MTRs).

4.3.5 Valves installed on transmission pipelines shall have records documenting the manufacturing standard and pressure rating to which each valve was manufactured and tested.

4.3.6 Flanges, fittings, branch connections, extruded outlets, anchor forgings and other components installed on transmission pipelines after December 31, 2020 with material yield strength of 42,000 psi (X42) or greater and nominal diameter greater than 2 inches shall have records documenting the manufacturing specifications in effect at the time of manufacturing including:

1. Yield strength,
2. Ultimate tensile strength, and
3. Chemical composition.

Records for fittings 2 inches and smaller should be kept when available.

4.3.7 These material records shall be retained for the life of the pipeline.

4.3.8 Transmission pipelines installed on or before July 1, 2020 which do not have the records necessary to establish the MAOP of the pipeline segment may require reconfirmation of MAOP as determined by Integrity Management.

4.4 For additional construction requirements, see [MAIN 1](#) for main installations and [SERV 1](#) for service line installations.

5.0 Joining

5.1 Welding is the preferred method for joining steel pipe. See [WELD 2.3](#) Construction of Pipelines and Piping Systems and [WELD 4](#) for acceptable welding processes and procedures.

5.2 Threading is acceptable for joining steel pipe that is used for aboveground assemblies such as meter sets, pressure control stations, odorization stations, compressor stations, etc.

5.3 Threaded caps are approved for use in abandoning gas facilities. See [ABND 2.1](#).

6.0 Bends and Elbows (49 CFR §192.313)

6.1 A field bend in steel pipe must not impair the serviceability of the pipe.

6.2 Make bends before joining the lengths of steel pipe together.

6.3 Each bend must be free from buckling, cracks, or any other mechanical damage.

6.3.1 When bending steel pipe, ensure that the coating is not damaged, and the pipe is not kinked. **Wrinkle bends are prohibited.**

6.3.2 When bending coated pipe, place belting between the bending shoe and the pipe.

6.4 On pipe containing a longitudinal weld, the longitudinal weld must be as near as practicable to the neutral axis of the bend unless:

6.4.1 The bend is made with an internal bending mandrel, or

6.4.2 The pipe has outside diameter of 12 inches or less, or diameter-to-wall thickness ratio less than 70.

6.5 The minimum bending radius for steel pipe is 12 times the outside diameter. See Table 1 for minimum bend radius.

Table 1: Minimum Bend Radius

Steel Pipe Size	Minimum Bend Radius
3/4"	13"
1 1/4"	20"
2"	29"
3"	42"
4"	54"
6"	80"
8"	104"
10"	129"

- 6.6 After the bending process, nondestructive testing must be performed on each circumferential weld located where stress during bending causes a permanent deformation in the pipe.
- 6.7 Fittings should be used when bending the pipe is not feasible or possible.
- 6.8 Wrought steel welding elbows and transverse segments of these elbows may not be used for changes in direction on steel pipe that is 2 inches or more in diameter unless the arc length, as measured along the crotch, is at least 1 inch.

7.0 Casing Requirements (49 CFR §192.323)

- 7.1 See [STLP 2.1](#) for casing installation requirements.

8.0 Pipe Coating and Corrosion Control

- 8.1 See [CORR 2.3](#) for approved pipe joint coatings and proper application of coatings.
- 8.2 See [CORR 1](#) for corrosion control requirements.
- 8.3 All 2-inch and larger coated steel pipe installations greater than 100 feet in length, including field coated and wrapped joints, shall have the coating tested ("jeeped") with a "holiday detector". See [CORR 2.3](#) for coating testing requirements.
- 8.4 All defects found in the pipe's protective coating shall be repaired. See [CORR 2.3](#) for coating repair methods.

9.0 Damage During Construction

- 9.1 Each imperfection or damage that impairs the serviceability of a segment of steel pipe must be repaired or removed.
- 9.2 See [REPR 1](#) for repair requirements.

10.0 Buried Pipe Examination

- 10.1 A Buried Pipe Examination form must be completed whenever an existing gas carrying steel main or service is exposed and will be left in service after the DOJM/WO project has been finalized. See [CORR 1](#).

11.0 Corrosion and Steel Damage Evaluation

- 11.1 Whenever there is corrosion or damage to an existing gas carrying steel main or service, a Corrosion and Steel Damage Evaluation must be completed by the Corrosion Control person for the area or a person qualified to evaluate corrosion or damage to the steel pipe. See [CORR 1](#) for instructions.

12.0 Pipe Thread Sealers

- 12.1 All threaded connections should be made using an approved pipe thread sealer or gas thread tape.

Table 2: Approved Pipe Thread Sealers

Stock No.	Product	Maximum Pressure	Temperature Rating	Shelf Life	HMS (Table 3)
4922421	J.C. Whitlam T-U Type 555, 8 oz	3,000 psig	-50°F thru 400°F	None	H0, F2,

UNCONTROLLED IF PRINTED

	Note (1)				R0, PA
3052500	Bakerseal, 16 oz Note (2)	No max pressure	0°F thru 600°F	2 years	H1, F1, R0, PB
3052532	Hercules Real-Tuff	2,600 psig	-200°F thru 550°F	2 – 3 years	H0, F0, R0, PA
3052533	Hercules Megaloc	2,600 psig	-50°F thru 400°F	2 years	H0, F0, R0, PA
3052534	LA-CO Slic-Tite	3,000 psig	-50°F thru 500°F	2 years	H1, F1, R0, PA
49 22 464	RectorSeal T Plus 2	2,000	-40°F thru 300°F	2 years	H1, F1, R0, PB
25 53 245	Blue Monster Teflon Thread Tape	1,500	-450°F thru 500°F	30 years	H0, F0, R0, PA
25 53 166	Yellow Gas Thread Tape	300	-450°F thru 500°F	None	H0, F1, R0, PA
25 53 202	White Teflon Tape	10,000	-450°F thru 500°F	None	H0, F1, R0, PA

Note (1): J.C. Whitlam T-U Type 555: Brushable to -50°F. Use teflon thread tape on 4 inch and larger pipe prior to thread sealer.

Note (2): Bakerseal: Brushable to 0°F

Table 3: Hazardous Materials Identification System (HMIS)

H - Health Hazard (Blue)	F - Flammability (Red)	R - Reactivity Hazard (Yellow)	P - Personal Protection (White)
H0 - No significant risk to health	F0 - Material will not burn F1 - Material must be preheated be-	R0 - Material is normally stable, even under fire conditions, and will not react with water, polymerize, de-	PA - Safety glasses PB - Safety glasses, gloves

UNCONTROLLED IF PRINTED

H1 - Irritation or minor reversible injury possible	fore ignition will occur F2 - Material must be moderately heated or exposed to high ambient temperature before ignition will occur	compose, condense, or self-react, non-explosive	
--	--	---	--

End of Instructions.

Operator Qualification (OQ) Required?

NO.

Appendices

NONE.

Attachments

NONE.

Compliance Requirements

49 CFR Part 192 - Amendments published October 1, 2019 in [84 FR 52245](#)

§192.127 Records: Pipe design.

§192.917 How does an operator identify potential threats to pipeline integrity and use the threat identification in its integrity program?

49 CFR Part 192 Subpart B - Materials

49 CFR Part 192 Subpart C - Pipe Design

Reference Documents

[ABND 2.1 Abandonment of Facilities: Abandonment of Gas Facilities](#)

[CORR 1 Corrosion Control: Requirements](#)

[CORR 2.3 Corrosion Control: Coatings](#)

[MAIN 1 Main Installation: Requirements](#)

[REPR 1 Repairs: Requirements](#)

[SERV 1 Service Line Installation: Requirements](#)

[STLP 2.1 Steel Pipe: Casing Pipe Installation](#)

[STLP 2.2 Steel Pipe: Design Pressure](#)

[WELD 2.3 Welding: Construction of Pipelines](#)

[WELD 4 Welding: Forms and Reference Materials](#)

Document Rescission

STLP 1 Steel Pipe: Requirements, October 1, 2022

UNCONTROLLED IF PRINTED

Revision Notes

Location of Changes	Summary of Changes
Section 12.0	Removed Subsection 12.2 which was specifications for thread sealer. Specifications are the responsibility of Gas Standards and do not need to be in O&M

STLP 2.1 Casing Pipe Installation

1.0 Purpose

This document specifies the requirements and design for a casing pipe installation.

2.0 Scope

This document addresses the following:

[3.0 Target Audience](#)

[4.0 General](#)

[5.0 Casing Installation](#)

[6.0 Link-Seal Installation](#)

[7.0 Gel Filled Casing](#)

3.0 Target Audience

- Gas Engineering
- Gas Tech Engineering (GTE)
- Gas Storage Engineering (GSE)
- Gas Field Personnel
- Gas Supervisors
- Corrosion Control Supervisors
- Corrosion Control Specialist
- Gas Construction Services personnel

4.0 General

- 4.1 Casings are installed when required for a railroad or highway crossing in order to allow the section of pipe under the crossing to be replaced without disturbing the facility being crossed.
- 4.2 Casing installations, for the purpose of this document, involve:
- 4.2.1 A steel or PE carrier pipe, and
- 4.2.2 A steel casing pipe.

Carrier pipe (gas main) must be coated and protected steel. Bare steel pipe is recommended for casing pipe but steel pipe with old coating can also be used.

- 4.3 Casings must be designed to withstand external loads.

5.0 Casing Installation

- 5.1 Refer to [Figure 1](#) for typical casing installation. Refer to [Table 1](#) for casing pipe sizes and required number of end seal links (Link Seals, [Figure 2](#)) for a given carrier pipe size.
- 5.2 Install vents before installing carrier pipe. The vents shall be a minimum of 2" pipe. If vents are installed on a casing, then the casing must be vented away from potential

sources of ignition. The vent termination must be protected to prevent rain water, insects, etc. from entering the casing.

- 5.3 Pipe insulators for steel carrier pipe must be installed in accordance with manufacturer's specifications to separate the carrier pipe from the casing. See [Figure 3](#).
- 5.4 If a steel carrier pipe is installed in a steel casing, the carrier pipe and casing must be electrically isolated. If a steel carrier pipe is installed in a steel casing, the carrier pipe and casing shall be electrically isolated. Attach 2 tracer wires to the carrier pipe ([Figure 1](#)) and terminate the wires above ground in a test box. Refer to [CORR 2.7 Section 10.0](#) Short Investigation and Clearing Shorted Pipelines, Casings.
- 5.5 The ends of the casing pipe must be sealed using end seals (Link Seals).
- 5.6 When backfilling, maintain clearance between vent pipe and carrier pipe.
 - 5.6.1 Support casing end and carrier pipe extending from casing with concrete blocks, as necessary, to maintain alignment during backfilling.
 - 5.6.2 Use fiberglass insulators or approved material to protect coated carrier pipe.
- 5.7 Install pipeline signs on each casing vent.

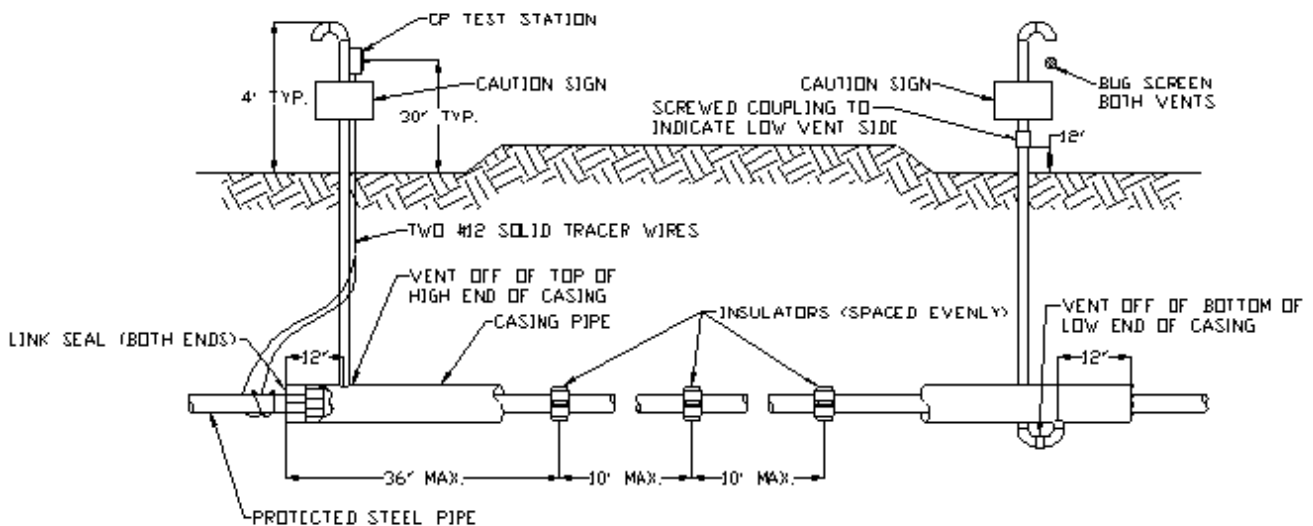

Figure 1: Typical Casing Installation

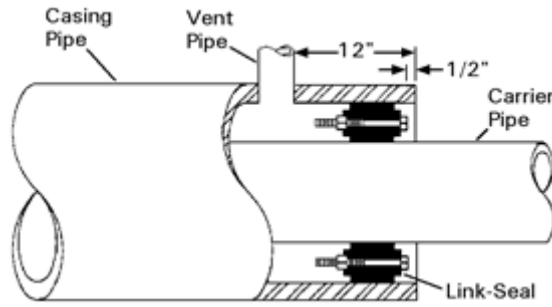

Figure 2: Link Seal

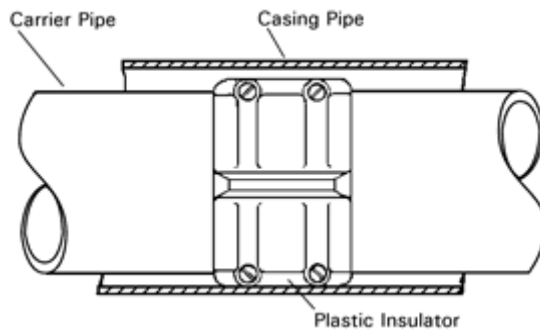

Figure 3: Insulator

Table 1: Casing Sizes, End Seals (Link Seals) and Insulators

Carrier Pipe Size	Casing Pipe Size	Links Required	Link Seal Number	Link Seal Stock No.	Insulator Stock No.
3/4"	3"	4	LS-300-C	19 12 049	
1 1/4"	3"	4	LS-300-C	19 12 049	25 59 108
2"	4"	6	LS-300-C	19 12 049	25 59 057
4"	8"	7	LS-475-C	19 12 051	25 59 086
6"	10"	10	LS-475-C	19 12 051	25 59 061
8"	12"	12	LS-475-C	19 12 051	25 59 062
10"	14"	10	LS-425-C	19 12 050	25 59 115
12"	16"	12	LS-425-C	19 12 050	

6.0 Link-Seal Installation

- 6.1 Link-seals are packaged preassembled in 10-link units. Add or subtract links as required. See [Table 1](#) for required number of links.
- 6.2 *3/4" Carrier in 2" Casing only:* Use 2" casing for 3/4" carrier pipe by belling out ends to accommodate end seals. See Figure 4.

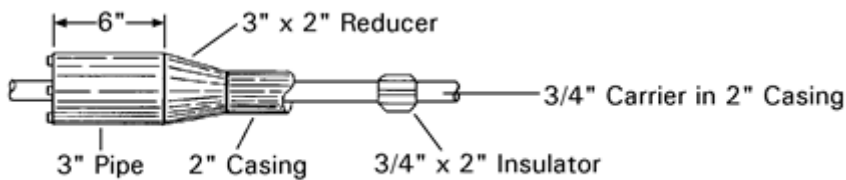

Figure 4: 3/4" Carrier in 2" Casing

- 6.3 Connect the first and last links to form a loose belt around the carrier pipe.
- 6.4 Each nut fits into a special pocket in its pressure plate which prevents the nut from turning when the bolt head is tightened. Make sure a pressure plate is installed under each bolt head and nut. See Figure 5.

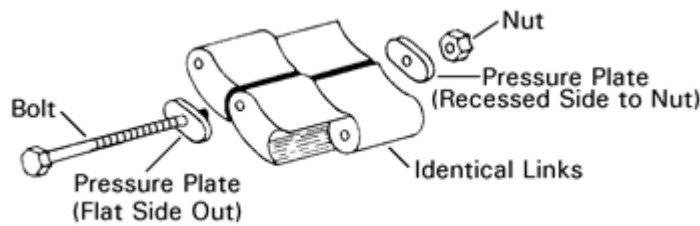

Figure 5: Link assembly

- 6.5 Slide the assembled link-seal into the angular space between the carrier pipe and casing.
- 6.6 Tighten the bolt heads. The elongated pressure plates compress the rubber links which expand to form a continuous seal between carrier pipe and casing.
- 6.7 Coat exposed bolt heads on seal with an approved coating material.

7.0 Gel Filled Casing

- 7.1 Gas Tech Engineering, in consultation with Corrosion Control personnel, will provide detailed plans and instructions on gel filling procedures. See Figure 6.

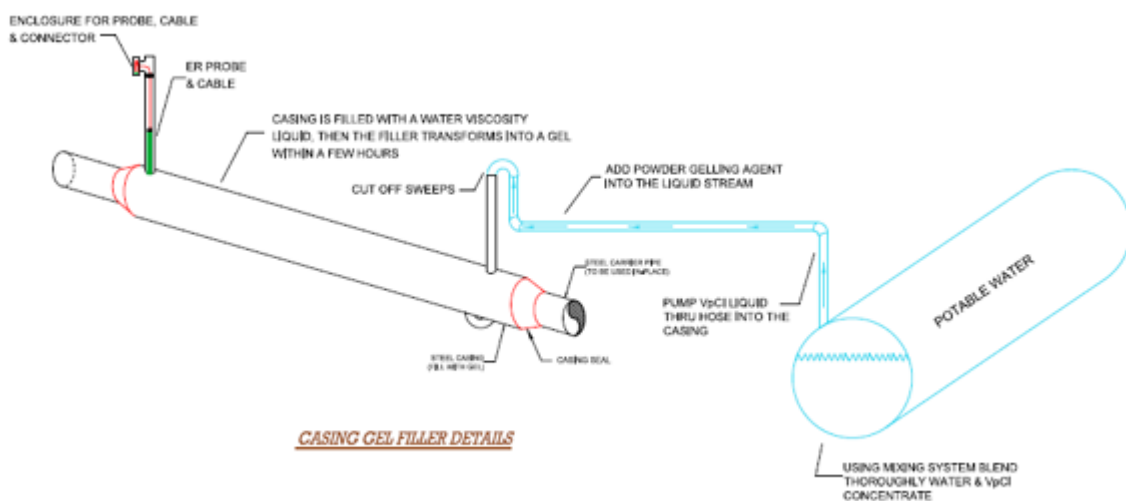

Figure 6: Typical Casing Gel Filler Details

- 7.2 The enclosure and vent valve shown (Figure 7) are samples of the equipment that Gas Tech Engineering or Corrosion Control may want to install on the casing vent stacks.



Enclosure for Probe, Cable, and Connector



Casing Stack Vent Valve

Figure 7: Enclosure and Vent Valve for Casing Vent Stack

End of Instructions.

Operator Qualification (OQ) Required?

NO.

Appendices

NONE.

Attachments

NONE.

Compliance Requirements

49 CFR §192.323 Casing.

Reference Documents

[CORR 2.7 Corrosion Control: Short Investigation and Clearing Shorted Pipelines](#)

GPT Industries LINK-SEAL® ([online here](#))

Document Rescission

UNCONTROLLED IF PRINTED

STLP 2.1 Steel Pipe: Casing Pipe Installation, October 1, 2020.

Revision Notes

Location of Changes	Summary of Changes
4.0 General	Added 4.3 – Casing must be designed to withstand external loads.

STEEL PIPE

May 15, 2022

STLP 2.2 Design Pressure**1.0 Purpose**

This document specifies the design formula, design parameters and typical values applicable to steel pipeline design in accordance with 49 CFR §192.105.

2.0 Scope

This document addresses the following:

[3.0 Target Audience](#)**[4.0 Procedures](#)**

Appendices

[Appendix A - Steel Pipe Stock Code Table](#)**3.0 Target Audience**

- Gas Engineering
- Gas Tech Engineering (GTE)
- Gas Storage Engineering (GSE)

4.0 Procedures**4.1 Design Formula (49 CFR §192.105)**

The design pressure for steel pipe is determined in accordance with the following formula:

$$P = (2St/D) \times F \times E \times T$$

P = Design pressure in psig

S = Yield strength in psi

D = Nominal outside diameter of the pipe in inches

t = Nominal wall thickness of the pipe in inches

F = Design factor (see [4.4](#) below).

E = Longitudinal joint factor (see [4.5](#) below)

T = Temperature derating factor (see [4.6](#) below)

4.2 Nominal Outside Diameter

Table 1 shows the nominal outside diameter (D) for commercial pipe in accordance with ASTM A53 and API 5L.

Table 1: Pipe Size and Nominal Outside Diameter (D)

Nominal Pipe Size (NPS)	Nominal Outside Diameter (inches)	Nominal Pipe Size (NPS)	Nominal Outside Diameter (inches)	Nominal Pipe Size (NPS)	Nominal Outside Diameter (inches)
3/4	1.050	5	5.563	22	22.000

UNCONTROLLED IF PRINTED

1	1.315	6	6.625	24	24.000
1-1/4	1.660	8	8.625	26	26.000
1-1/2	1.900	10	10.750	28	28.000
2	2.375	12	12.750	30	30.000
2-1/2	2.875	14	14.000	32	32.000
3	3.500	16	16.000	34	34.000
3-1/2	4.000	18	18.000	36	36.000
4	4.500	20	20.000	42	42.000

4.3 Nominal Wall Thickness (49 CFR §192.109)

4.3.1 Nominal wall thickness (t) is shown in [Appendix A](#), Steel Pipe Stock Code Table. Wall thickness for pipe not listed can be found in Pipe Fitters Handbook, ASTM A53, or API 5L.

4.3.2 If the wall thickness is not known, refer to procedures in 49 CFR §192.109 that describe how to obtain the wall thickness through actual measurements.

4.3.3 Additional wall thickness required to protect the pipe from anticipated external pressure or loads may not be included in computing design pressure.

4.4 Design Factor (49 CFR §192.111)

4.4.1 Use Table 2 to determine the design factor to be used in the design formula, unless there is an exception ([Section 4.4.2](#)):

Table 2: Class Location and Design Factor (F)

Class Location	Design Factor (F)
1	0.72
2	0.60
3	0.50
4	0.40

4.4.2 Exceptions:

1. A design factor of 0.60 or less must be used for steel pipe in Class 1 locations that:
 - 1 a. Crosses the right-of-way of an un-improved public road, without a casing;
 - 1 b. Crosses without a casing, or makes a parallel encroachment on the right-of-way of; a hard-surfaced road, a highway, a public street, or a railroad.
 - 1 c. Is supported by a vehicular, pedestrian, railroad, or pipeline bridge; or
 - 1 d. Is used in a fabrication assembly, (including separators, mainline valve assemblies, cross-connections, and river crossing headers) or is used within five pipe diameters in any direction from the last fitting of a fabricated assembly, other than a transition piece or an elbow used in place of a pipe bend which is not associated with a fabricated assembly.

2. For Class 2 locations, a design factor of 0.50 or less must be used for uncased steel pipe that crosses the right-of-way of a hard-surfaced road, a highway, a public street, or a railroad.
3. For Class 1 and Class 2 locations, a design factor of 0.50 or less must be used for:
 - 3 a. Steel pipe in a compressor station, or measuring station, and
 - 3 b. Steel pipe, including a pipe riser, on a platform located in inland navigable waters.

4.4.3 A design factor for Class 3 or Class 4 locations should be used for Ameren Illinois' gas systems.

4.5 Longitudinal Joint Factor (49 CFR §192.113)

4.5.1 Use [Table 3](#) to determine the longitudinal joint factor to be used in the design formula. If the type of longitudinal joint cannot be determined, the joint factor must not exceed that designated for "Other."

Table 3: Longitudinal Joint Factor (E)

Specification	Pipe Class	Longitudinal Joint Factor (E)
ASTM A53/A53M	Seamless	1.00
	Electric resistance welded	1.00
	Furnace butt welded	0.60
ASTM A106	Seamless	1.00
ASTM A333/A333M	Seamless	1.00
	Electric resistance welded	1.00
ASTM A381	Double submerged arc welded	1.00
ASTM A671	Electric-fusion-welded	1.00
ASTM A672	Electric-fusion-welded	1.00
ASTM A691	Electric-fusion-welded	1.00
API 5L	Seamless	1.00
	Electric resistance welded	1.00
	Electric flash welded	1.00
	Submerged arc welded	1.00
	Furnace butt welded	0.60
Other	Pipe over 4 inches	0.80
	Pipe 4 inches or less	0.60

4.6 Temperature Derating Factor (49 CFR §192.115)

4.6.1 Use Table 4 to determine the temperature derating factor to be used in the design formula:

Table 4: Temperature Derating Factor (T)

Gas Temperature	Temperature Derating Factor (T)
250°F or less	1.000
300°F	0.967

350°F	0.933
400°F	0.900
450°F	0.867

4.6.2 For intermediate gas temperatures, the derating factor is determined by interpolation.

4.7 Steel Pipe Stock Code Table

4.7.1 See [Appendix A](#).

4.8 Dual Coat Steel Pipe

4.8.1 Dual coated pipe shall be coated with Fusion Bonded Epoxy (FBE) and with an Abrasive Resistant Overlay (ARO) in accordance with [CORR 2.3 Section 4.1.2](#) Directional Drilling Installation.

4.8.2 Mil thickness of ARO varies significantly between pipe manufacturers depending on current orders. The total coating thickness must be measured with a dry film coating thickness detector in order to determine inspection voltage. See [CORR 2.3 Section 11.0](#) Coating Inspection.

4.8.3 All stock coded dual coated pipe is X-52 pipe and double random length.

End of Instructions.

Operator Qualification (OQ) Required?

NO.

Appendices

[Appendix A - Steel Pipe Stock Code Table](#)

Attachments

NONE.

Compliance Requirements

49 CFR 192 Subpart C - Pipe Design

§192.101 Scope.

§192.103 General.

§192.105 Design formula for steel pipe.

§192.107 Yield strength (S).

§192.109 Nominal wall thickness (t) for steel pipe.

§192.112 Additional design requirements for steel pipe using alternative maximum allowable operating pressure.

§192.113 Longitudinal joint factor (E) for steel pipe.

§192.115 Temperature derating factor (T) for steel pipe.

Reference Documents

[CORR 2.3 Corrosion Control: Coatings](#)

ASTM A53 Standard Specification for Pipe, Steel, Black and Hot-Dipped, Zinc-Coated, Welded and Seamless

API 5L Specification for Line Pipe

Pipe Fitters Handbook

Document Rescission

STLP 2.01 Steel Pipe: Design Pressure, April 1, 2021

Revision Notes

Location of Changes	Summary of Changes
Appendix A	Updated – Additional stock coded pipe listed
Appendix A Note (6)	Updated the Gas Standards and Procedures SharePoint site and link to the Specifications & Standards

Appendix A - Steel Pipe Stock Code Table

Nominal Pipe Size (in.)	Pipe Sched.	De-script. Note (5)	Stock No.	Length	Pipe OD (in.)	Wall Thick. (in.)	Minimum Yield (psi) Note (3)	Design Pressure (psi)			
								100% SMYS	50% SMYS (Class 3) Design Factor 0.50 Note (2)	30% SMYS	20% SMYS
3/4	40	Bare	32 23 301	SRL	1.050	0.113	35,000	7,533	3,767	2,260	1,507
3/4	40	FBE	32 23 302	SRL	1.050	0.113	35,000	7,533	3,767	2,260	1,507
3/4	80	Bare	32 23 264	SRL	1.050	0.154	35,000	10,267	5,133	3,080	2,053
3/4	80	FBE	32 23 303	SRL	1.050	0.154	35,000	10,267	5,133	3,080	2,053
1	40	Bare	32 23 306	SRL	1.315	0.133	35,000	7,080	3,540	2,124	1,416
1	40	FBE	32 23 258	SRL	1.315	0.133	35,000	7,080	3,540	2,124	1,416
1	80	Bare	32 23 260	SRL	1.315	0.179	35,000	9,529	4,764	2,858	1,905
1	80	FBE	32 23 261	SRL	1.315	0.179	35,000	9,529	4,764	2,858	1,905
1-1/4	40	Bare	32 23 311	SRL	1.660	0.140	35,000	5,904	2,952	1,771	1,181
1-1/4	40	FBE	32 23 312	SRL	1.660	0.140	35,000	5,904	2,952	1,771	1,181
1-1/2	80	Bare	32 23 265	SRL	1.900	0.200	35,000	7,368	3,684	2,210	1,473
1-1/2	80	FBE	32 23 271	SRL	1.900	0.200	35,000	7,368	3,684	2,210	1,473

UNCONTROLLED IF PRINTED

Ameren Illinois Gas O&M Plan - April 1, 2023

2	40	Bare	32 23 317	SRL	2.375	0.154	52,000	6,744	3,372	2,023	1,
2	40	FBE	32 23 319	DRL	2.375	0.154	52,000	6,744	3,372	2,023	1,
2	40	FBE & ARO	32 23 321	DRL	2.375	0.154	52,000	6,744	3,372	2,023	1,
2	80	Bare	32 23 318	SRL	2.375	0.218	52,000	9,546	4,773	2,864	1,
2	80	FBE	32 23 320	DRL	2.375	0.218	52,000	9,546	4,773	2,864	1,
2	80	FBE & ARO	32 23 257	DRL	2.375	0.218	52,000	9,546	4,773	2,864	1,
3	Note (1)	Bare	32 23 285	DRL	3.500	0.188	52,000	5,586	2,793	1,676	1,
3	Note (1)	FBE	32 23 197	DRL	3.500	0.188	52,000	5,586	2,793	1,676	1,
3	40	Bare	32 23 132	SRL	3.500	0.216	52,000	6,418	3,209	1,925	1,
3	40	FBE	32 23 259	SRL	3.500	0.216	52,000	6,418	3,209	1,925	1,
3	40	FBE & ARO	32 23 262	SRL	3.500	0.216	52,000	6,418	3,209	1,925	1,
4	Note (1)	Bare	32 23 327	SRL	4.500	0.188	52,000	4,345	2,172	1,303	8
4	Note (1)	FBE	32 23 330	DRL	4.500	0.188	52,000	4,345	2,172	1,303	8
4	40	Bare	32 23 328	SRL	4.500	0.237	52,000	5,477	2,739	1,643	1,
4	40	FBE	32 23 331	DRL	4.500	0.237	52,000	5,477	2,739	1,643	1,
4	40	FBE & ARO	32 23 332	DRL	4.500	0.237	52,000	5,477	2,739	1,643	1,
4	80	Bare	32 23 263	DRL	4.500	0.337	52,000	7,788	3,894	2,336	1,
4	80	FBE	32 23 266	DRL	4.500	0.337	52,000	7,788	3,894	2,336	1,
4	80	FBE & ARO	32 23 267	DRL	4.500	0.337	52,000	7,788	3,894	2,336	1,
6	Note (1)	Bare	32 23 337	SRL	6.625	0.219	52,000	3,438	1,719	1,031	6

UNCONTROLLED IF PRINTED

6	Note (1)	FBE	32 23 340	DRL	6.625	0.219	52,000	3,438	1,719	1,031	6
6	40	Bare	32 23 338	SRL	6.625	0.280	52,000	4,395	2,198	1,319	8
6	40	FBE	32 23 341	DRL	6.625	0.280	52,000	4,395	2,198	1,319	8
6	40	FBE & ARO	32 23 342	DRL	6.625	0.280	52,000	4,395	2,198	1,319	8
6	80	Bare	32 23 269	DRL	6.625	0.432	52,000	6,781	3,390	2,034	1,
6	80	FBE	32 23 270	DRL	6.625	0.432	52,000	6,781	3,390	2,034	1,
6	80	FBE & ARO	32 23 268	DRL	6.625	0.432	52,000	6,781	3,390	2,034	1,
8	20	FBE	32 23 348	DRL	8.625	0.250	52,000	3,014	1,507	904	6
8	40	Bare	32 23 346	SRL	8.625	0.322	52,000	3,883	1,941	1,165	7
8	40	FBE	32 23 349	DRL	8.625	0.322	52,000	3,883	1,941	1,165	7
8	40	FBE & ARO	32 23 350	DRL	8.625	0.322	52,000	3,883	1,941	1,165	7
8	80	Bare	32 23 273	DRL	8.625	0.500	52,000	6,028	3,014	1,808	1,
8	80	FBE	32 23 272	DRL	8.625	0.500	52,000	6,028	3,014	1,808	1,
8	80	FBE & ARO	32 23 274	DRL	8.625	0.500	52,000	6,028	3,014	1,808	1,
10	20	FBE	32 23 353	DRL	10.750	0.250	52,000	2,419	1,209	726	4
10	20	FBE & ARO	32 23 249	DRL	10.750	0.250	52,000	2,419	1,209	726	4
10	40	Bare	32 23 351	DRL	10.750	0.365	52,000	3,531	1,766	1,059	7
10	40	FBE	32 23 354	DRL	10.750	0.365	52,000	3,531	1,766	1,059	7
10	40	FBE & ARO	32 23 355	DRL	10.750	0.365	52,000	3,531	1,766	1,059	7
10	80	Bare	32 23 275	DRL	10.750	0.500	52,000	4,837	2,418	1,451	9
10	80	FBE	32 23 277	DRL	10.750	0.500	52,000	4,837	2,418	1,451	9

UNCONTROLLED IF PRINTED

10	80	FBE & ARO	32 23 276	DRL	10.750	0.500	52,000	4,837	2,418	1,451	9
12	20	Bare	32 23 256	DRL	12.750	0.250	52,000	2,039	1,020	612	4
12	20	FBE	32 23 358	DRL	12.750	0.250	52,000	2,039	1,020	612	4
12	Note (1)	FBE & ARO	32 23 360	DRL	12.750	0.312	52,000	2,545	1,272	763	5
12	Std	Bare	32 23 356	SRL	12.750	0.375	52,000	3,059	1,529	918	6
12	Std	FBE	32 23 359	DRL	12.750	0.375	52,000	3,059	1,529	918	6
12	Std	FBE & ARO	32 23 255	DRL	12.750	0.375	52,000	3,059	1,529	918	6
12	XStr	Bare	32 23 250	DRL	12.750	0.500	52,000	4,078	2,039	1,224	8
12	XStr	FBE	32 23 284	DRL	12.750	0.500	52,000	4,078	2,039	1,224	8
12	XStr	FBE & ARO	32 23 364	DRL	12.750	0.500	52,000	4,078	2,039	1,224	8
14	10	FBE & ARO	32 23 363	DRL	14.000	0.250	52,000	1,875	929	557	3
14	Std	Bare	32 23 286	Bare	14.000	0.375	52,000	2,786	1,393	836	5
14	Std	FBE	32 23 361	DRL	14.000	0.375	52,000	2,786	1,393	836	5
14	XStr	Bare	32 23 287	DRL	14.000	0.500	52,000	3,714	1,857	1,114	7
14	XStr	FBE	32 23 288	DRL	14.000	0.500	52,000	3,714	1,857	1,114	7
14	XStr	FBE & ARO	32 23 357	DRL	14.000	0.500	52,000	3,714	1,857	1,114	7
16	20	FBE	32 23 366	DRL	16.000	0.312	52,000	2,028	1,014	608	4
16	Std	Bare	32 23 254	SRL	16.000	0.375	52,000	2,438	1,219	731	4
16	Std	FBE	32 23 253	DRL	16.000	0.375	52,000	2,438	1,219	731	4
16	Std	FBE & ARO	32 23 368	DRL	16.000	0.375	52,000	2,438	1,219	731	4
16	40	Bare	32 23 251	DRL	16.000	0.500	52,000	3,250	1,625	975	6

UNCONTROLLED IF PRINTED

Ameren Illinois Gas O&M Plan - April 1, 2023

16	40	FBE	32 23 278	DRL	16.000	0.500	52,000	3,250	1,625	975	6
16	40	FBE & ARO	32 23 367	DRL	16.000	0.500	52,000	3,250	1,625	975	6
18	10	FBE	32 23 371	DRL	18.000	0.250	60,000	1,667	833	500	3
18	Std	Bare	32 23 289	DRL	18.000	0.375	52,000	2,167	1,083	650	4
18	Std	FBE	32 23 372	DRL	18.000	0.375	52,000	2,167	1,083	650	4
18	Std	FBE & ARO	32 23 374	DRL	18.000	0.375	52,000	2,167	1,083	650	4
18	XStr	Bare	32 23 290	DRL	18.000	0.500	52,000	2,889	1,444	867	5
18	XStr	FBE	32 23 291	DRL	18.000	0.500	52,000	2,889	1,444	867	5
18	XStr	FBE & ARO	32 23 373	DRL	18.000	0.500	52,000	2,889	1,444	867	5
20	10	FBE	32 23 376	DRL	20.000	0.250	52,000	1,300	650	390	2
20	20	Bare	32 23 279	DRL	20.000	0.375	52,000	2,250	1,125	675	4
20	20	FBE	32 23 280	DRL	20.000	0.375	52,000	2,250	1,125	675	4
20	20	FBE & ARO	32 23 377	DRL	20.000	0.375	52,000	2,250	1,125	675	4
20	XStr	Bare	32 23 252	DRL	20.000	0.500	52,000	2,600	1,300	780	5
20	XStr	FBE	32 23 281	DRL	20.000	0.500	52,000	2,600	1,300	780	5
20	XStr	FBE & ARO	32 23 378	DRL	20.000	0.500	52,000	2,600	1,300	780	5
24	20	Bare	32 23 282	DRL	24.000	0.375	52,000	1,625	813	488	3
24	20	FBE	32 23 381	DRL	24.000	0.375	52,000	1,625	813	488	3
24	20	FBE & ARO	32 23 383	DRL	24.000	0.375	52,000	1,625	813	488	3
24	XStr	Bare	32 23 283	DRL	24.000	0.500	52,000	2,166	1,083	649	4
24	XStr	FBE	32 23 292	DRL	24.000	0.500	52,000	2,166	1,083	649	4

UNCONTROLLED IF PRINTED

24	XStr	FBE & ARO	32 23 293	DRL	24.000	0.500	52,000	2,166	1,083	649	4
30	Std	FBE	32 23 386	DRL	30.000	0.375	52,000	1,300	650	390	2
30	Std	FBE & ARO	32 23 387	DRL	30.000	0.375	52,000	1,300	650	390	2
30	XStr	Bare	32 23 294	DRL	30.000	0.500	52,000	1,733	866	519	3

Notes:

- (1) Pipe Manufacturers classify this wall thickness as Non-Schedule pipe.
- (2) All design calculations must use Class 3 design factor.
- (3) Yield (psi) - Yield strength shown in table is minimum strength.
- (4) Multi-stenciled pipe will indicate a range of yield strengths and pipe grades. Pipe shall be inspected prior to use to ensure it meets yield strength requirements for its planned MAOP.
- (5) Coating - FBE is Fusion Bonded Epoxy, ARO - Abrasive Resistant Overlay
- (6) AIC-approved pipe specifications can be found on the Gas Standard and Procedures SharePoint site under Specifications & Standards or by clicking on the following link: [HERE](#)

STEEL PIPE

October 1, 2022

STLP 2.3 Steel Pipe Squeeze Off

1.0 Purpose

The purpose of this document is to prescribe the basic procedures for squeezing steel pipe in an emergency situation when an immediate shut-down of gas flow is required to minimize an imminent hazard to life or property.

2.0 Scope

This document addresses the following:

[3.0 Target Audience](#)

[4.0 Safety](#)

[5.0 Preparation](#)

[6.0 Squeeze-Off Operation](#)

[7.0 Squeeze-Off Removal](#)

3.0 Target Audience

- Gas Field Personnel
- Gas Supervisors
- Gas Tech Services (GTS)
- Gas Tech Services (GTS) Personnel
- Gas Storage Field Supervisors
- Gas Storage Field Operators
- Gas Construction Services Personnel
- Construction Services Personnel
- Construction Inspectors

4.0 Safety

- 4.1 Extreme caution must be used when squeezing steel pipe that is under pressure due to potential of the pipe splitting through a weld seam especially in the older vintage steel pipe.
- 4.2 The squeeze-off point should be in a non-hazardous environment. If the squeeze off is to be performed in a hazardous gas environment, gas field personnel should follow procedures in [WIGE 2.1](#) Hazardous Environment
- 4.3 Sufficient qualified manpower shall be on-site to:
 - 4.3.1 Keep unauthorized personnel from accessing the work area.
 - 4.3.2 Minimize the number of people around the area of the squeeze-off.
 - 4.3.3 Operate a fire extinguisher located upwind of but near where the squeeze-off is being performed.
- 4.4 Prior to beginning a squeeze-off operation:
 - 4.4.1 A second squeeze-off point location should be identified and made accessible. The location should be in a non-hazardous environment in the event the pipe splits at the first location. OR
 - 4.4.2 An isolation valve should be located and accessible. OR

UNCONTROLLED IF PRINTED

- 4.4.3 A line stopper fitting is either on-site or can be on-site within a reasonable time along with qualified installation personnel.

If there is concern that the pipe would split, Do Not attempt the squeeze

5.0 Preparation

- 5.1 The individual performing the squeeze-off shall be operator qualified, experienced in squeezing steel pipe and in operating the squeeze-off tool.
- 5.2 Ensure the squeeze-off tool is the proper size for the pipe being squeezed.
- 5.3 Ensure the squeeze-off tool will operate properly by inspecting for evidence of misuse, oil leaks, corrosion and lack of freedom of all moving parts.
- 5.4 Follow manufacturer's operating instructions. See to [STLP 4](#) Forms and Reference Materials.
- 5.5 Clean the area and inspect the pipe for physical damage or corrosion. Do not operate tool if any damage or corrosion is identified.

6.0 Squeeze-Off Operation

- 6.1 Locate the squeeze point a minimum of 3 pipe diameters from a girth weld or a fitting.

When locating squeeze point, remember that the squeezed-off point section of pipe will have to be isolated, removed and replaced with new section of pipe before initializing normal flow

- 6.2 If applicable, remove the locking pin allowing the yoke to swing freely.
- 6.3 Center the squeeze tool on the pipe.
- 6.4 Close the yoke and insert pin completely through the yoke.
- 6.5 Ground the squeeze tool.
- 6.6 Engage pump controls and pressurize the squeeze tool steadily against the pipe.
- 6.7 Pump the squeeze tool until flow control, typically a manageable leak rate of approximately 2%, has been achieved. 100% bubble tight closure should not be expected.

7.0 Squeeze-Off Removal

- 7.1 Before the squeeze-off tool can be removed, that portion of pipe will have to be isolated, removed and replaced before initializing normal flow.

Install electric bonding cable across the proposed cut location prior to cutting and separating the steel pipe. Reference [ACIG1-Paragraph 4.3.1](#)

7.2 Once the segment is isolated, release the pressure and confirm uniform squeeze blade retraction to full-up position.

7.3 Remove the squeeze tool from the pipe.

7.4 The removed pipe segment shall be in accordance with [REPR 1 Paragraph 6.1.3](#) minimum length of replacement segment.

Operator Qualification (OQ) Required?

YES

1151 Squeeze Off Steel Pipe

Appendices

NONE

Attachments

NONE.

Compliance Requirements

NONE

Reference Documents

[ACIG 1 Accidental Ignition – Requirements](#)

[REPR 1 Repairs – Requirements](#)

[STLP 4 Steel Pipe – Forms and Reference Materials](#)

[WIGE 2.1 Working In Gaseous Environment – Hazardous Environment](#)

Document Rescission

NONE

Revision Notes

Location of Changes	Summary of Changes
Not Applicable	This is a new document

1.0 Purpose

This document describes the requirements and design considerations for weld fittings, weld transition fittings, and weld end insulators approved for use at Ameren Illinois (AIC).

2.0 Scope

This document addresses the following:

[3.0 Target Audience](#)

[4.0 Weld Fittings \(49 CFR §192.149\)](#)

[5.0 Weld Transition Fittings](#)

[6.0 Weld End Insulators](#)

Appendices:

[Appendix A - Elbows and Returns](#)

[Appendix B - Reducing Elbows](#)

[Appendix C - Tees](#)

[Appendix D - Reducing Tees and Concentric Tees](#)

[Appendix E - Caps](#)

[Appendix F - Unions](#)

[Appendix G - Quick Opening Closures](#)

[Appendix H - Weld Transition Fittings](#)

[Appendix I - Weld End Insulators](#)

3.0 Target Audience

- Gas Engineering
- Gas Field Personnel - Welders
- Gas Supervisors
- Gas Tech Engineering (GTE)
- Gas Storage Engineering (GSE)
- Gas Tech Services (GTS) Supervisors
- Gas Tech Services (GTS) Personnel
- Gas Storage Supervisors
- Gas Storage Field Operators
- Gas Construction Services Supervisors
- Contract Welders
- Welding Inspectors

4.0 Weld Fittings (49 CFR §192.149)

4.1 The term "Weld Fitting" applies to butt weld fittings such as elbows, tees, caps, return bends, reducers, crosses, laterals, and factory welded extensions and transition sections common to line pipe interconnection.

4.2 Design Considerations

4.2.1 All weld fittings installed shall have a wall thickness consistent with the requirements for design stress and welding procedure. They shall be pressure rated or

have the capability of being pressure tested to at least meet the MAOP of the pipe the fitting is being attached.

4.2.2 Heavier wall fittings may be welded to thinner wall line pipe by tapering the joint area per [WELD 2.3 Appendix A](#) or by reboring, provided the chemical and physical properties of the pipe and fitting are comparable, and the remaining minimum wall thickness meets stress requirements.

4.2.3 Fittings intended to mate with hi-test line pipe must be so specified on requisition and the pipe specification, wall thickness, and MAOP given. Fittings of these higher stress levels may be tapered or special bored only by the manufacturer. Tapered transition pieces, machined to the proper dimensions, are to be used when tapering or reboring is not recommended.

4.3 See the following Appendices for stock codes for approved weld fittings.

4.3.1 [Appendix A - Elbows and Returns](#)

4.3.2 [Appendix B - Reducing Elbows](#)

4.3.3 [Appendix C - Tees](#)

4.3.4 [Appendix D - Reducing Tees and Concentric Tees](#)

4.3.5 [Appendix E - Caps](#)

4.3.6 [Appendix F - Unions](#)

4.3.7 [Appendix G - Quick Opening Closures](#)

5.0 Weld Transition Fittings

5.1 Special tapering is required on steel line pipe butt welds when adjoining wall thicknesses exceed the maximum allowable offset as follows:

5.1.1 3/32" (0.094") for hoop stress equal to or greater than 20% SMYS, or

5.1.2 1/8" (0.125") for hoop stress less than 20% SMYS.

5.2 When a transition taper is required in the pipe and/or fitting, it shall be made using a mechanical end preparation machine or by manual preparation.

5.3 The transition fitting shall be manufactured from pipe having a yield strength equal to that of the pipe or fitting to be mated to the tapered end. The minimum wall thickness after tapering must meet the MAOP requirements determined for the pipeline by the design formula.

5.4 See [Appendix H](#), Weld Transition Fitting Specifications.

6.0 Weld End Insulators

6.1 See [Appendix I](#) for stock codes for approved weld end insulators.

End of Instructions.

Operator Qualification (OQ) Required?

NO.

Appendices

[Appendix A - Elbows and Returns](#)

[Appendix B - Reducing Elbows](#)

UNCONTROLLED IF PRINTED

[Appendix C - Tees](#)

[Appendix D - Reducing Tees and Concentric Tees](#)

[Appendix E - Caps](#)

[Appendix F - Unions](#)

[Appendix G - Quick Opening Closures](#)

[Appendix H - Weld Transition Fittings](#)

[Appendix I - Weld End Insulators](#)

Attachments

NONE.

Compliance Requirements

49 CFR §192.149 Standard fittings.

Reference Documents

[WELD 2.3 Welding: Construction of Pipelines](#)

ASME/ANSI B16.9, Factory-Made Wrought Buttwelding Fittings

Document Rescission

STLP 3.01 Steel Pipe: Weld Fittings, April 1, 2021.

Revision Notes

Location of Changes	Summary of Changes
Appendix D – Reducing Tees and Concentric Tees	Title – Added - Tees Removed Stock Code 19 33 234 – 1-1/4" x 3/4" Reducing Tees.

Appendix A - Elbows and Returns

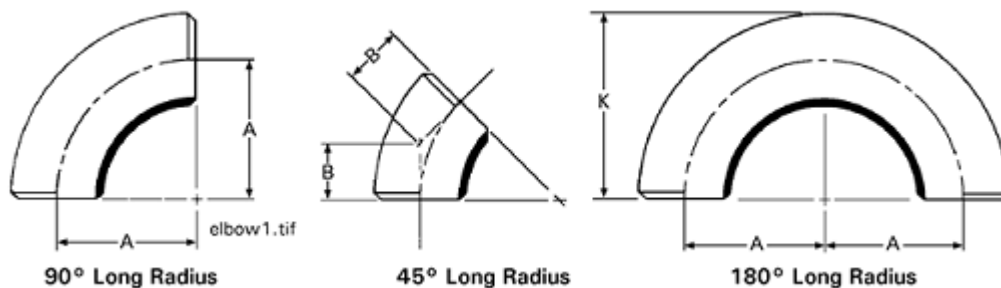

Elbow (3R) - 52,000 psig SMYS			
Nominal Pipe Size (inches)	Wall Thickness (inches)	Stock Code	
		45°	90°
4	0.237	19-33-704	19-33-636
6	0.280	19-33-609	19-33-611
8	0.322	19-33-643	19-33-640
10	0.365	19-33-614	19-33-615

UNCONTROLLED IF PRINTED

12	0.375	19-33-618*	19-33-619*
14	0.375	19-33-621*	19-33-622*
	0.250		19-33-718*
16	0.375	19-33-624*	19-33-625*
18	0.250		
	0.375	19-33-627*	19-33-629*
20	0.375	19-33-631*	19-33-632*
24	0.375	19-33-623*	19-33-633*
30	0.375		19-33-717*
Notes: (1) Y-60 * Denotes Coated Fittings			

Returns - Long Radius - 35,000 psig SMYS			
Nominal Pipe Size	Pipe Outside Diameter	Wall Thickness	Stock Code
2"	2.375"	0.154"	19-23-784

Elbows - Long Radius - 35,000 psig SMYS							
Nominal Pipe Size (inches)	Outside Diameter (inches)	Wall Thickness (inches)	Dimensions			Stock Code	
			A	B	K	45°	90°
3/4	1.050	0.113	1 1/8	7/16	1 11/16		19-23-902
1	1.315	0.133	1 1/2	7/8	2 3/16		19-23-910
1 1/4	1.660	0.140	1 7/8	1	2 3/4	19-23-880	19-23-916
2	2.375	0.154	3	1 3/8	4 3/16	19-08-505	19-08-293
		0.218				19-23-882	19-23-926
3	3.500	0.216	4 1/2	2	6 1/4	19-23-885	19-12-295
		0.300					
4	4.500	0.237	6	2 1/2	8 1/4	19-23-886	19-33-684
		0.337					
6	6.625	0.280	9	3 3/4	12 5/16	19-23-888	19-33-683
		0.219				19-23-037	
8	8.625	0.250	12	5	16 5/16		
		0.322				19-08-508	19-23-942
10	10.750	0.365	15	6 1/4	20 3/8	19-23-328	19-33-650
12	12.750	0.250	18	7 1/2	24 3/8	19-23-042*	
		0.375				19-23-330*	19-73-310*
14	14.000	0.250	21	8 3/4	28		
		0.375					
16	16.000	0.375	24	10	32		
18	18.000	0.250	27	11 1/2	36		
		0.375					19-23-344*
		0.500					
20	20.000	0.375	30	12 1/2	40		

UNCONTROLLED IF PRINTED

24	24.000	0.375	36	15	48		
		0.500				19-23-348*	
30	30.000	0.375	45	18 1/2	60		

Note: * Denotes Coated Fittings

Elbows - Long Radius - 52,000 psig SMYS							
Nominal Pipe Size (inches)	Outside Diameter (inches)	Wall Thickness (inches)	Dimensions			Stock Code	
			A (in)	B (in)	K (in)	45°	90°
4	4.500	0.237	6	2 1/2	8 1/4	19-33-634	
		0.337					
6	6.625	0.280	9	3 3/4	12 5/16	19-33-608	19-33-610
		0.432					
8	8.625	0.250	12	5	16 5/16		
		0.322				19-33-638	19-33-639
10	10.750	0.365	15	6 1/4	20 3/8	19-33-613	19-33-617
12	12.750	0.250	18	7 1/2	24 3/8		
		0.375				19-33-637*	19-33-705* (2)

Notes: (2) Segmentable, Coated
* Denotes Coated Fittings

Appendix B - Reducing Elbows

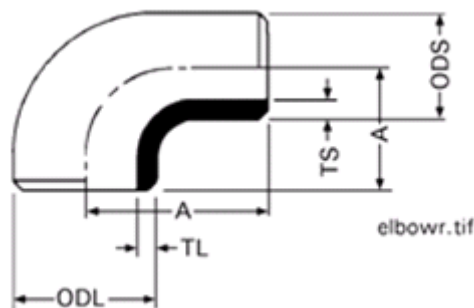

90° Reducing Elbows - 35,000 psi SMYS				
Nominal Pipe Size (inches)	Outside Diameter ODL x ODS (inches)	Center to Face (A) (inches)	Standard Weight	
			Thickness at End TL x TS (inches)	Stock Code
2 x 1	2.375 x 1.315	3	0.154 x 0.133	19-23-928
2 x 1 1/4	2.375 x 1.660	3	0.154 x 0.140	19-23-929
3 x 2	3.500 x 2.375	4 1/2	0.216 x 0.154	19-23-932
4 x 2	4.500 x 2.375	6	0.237 x 0.154	19-23-054
4 x 3	4.500 x 3.500	6	0.237 x 0.216	19-23-938
6 x 3	6.625 x 3.500	9	0.280 x 0.220	19-23-056
6 x 4	6.625 x 4.500	9	0.280 x 0.237	19-23-941
8 x 4	8.625 x 4.500	12	0.500 x 0.337	19-23-945

8 x 6	8.625 x 6.625	12	0.322 x 0.280	19-23-943
10 x 6	10.750 x 6.625	15	0.365 x 0.280	19-23-947
10 x 8	10.750 x 8.625	15	0.365 x 0.322	19-23-948

Appendix C - Tees

C-1. Straight Tees

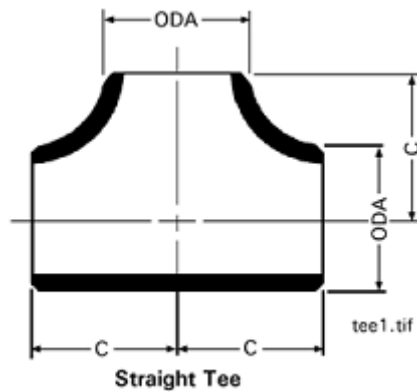

Straight Tees - 35,000 psig SMYS				
Nominal Pipe Size (inches)	Outside Diameter ODA (inches)	Wall Thickness (inches)	Dimension C (inches)	Stock Code
3/4	1.050	0.113	1 1/8	19-12-434
1	1.315	0.133	1 1/2	19-12-255
1 1/4	1.660	0.140	1 7/8	19-33-231
2	2.375	0.154	2 1/2	19-12-256
		0.218		19-33-584
3	3.500	0.216	3 3/8	19-33-244
4	4.500	0.237	4 1/8	19-33-644
6	6.625	0.280	5 5/8	19-33-657
8	8.625	0.219	7	19-23-120
		0.322		

Straight Tees - 52,000 psig SMYS				
Nominal Pipe Size (inches)	Outside Diameter ODA (inches)	Wall Thickness (inches)	Dimension C (inches)	Stock Code
4	4.500	0.237	4 1/8	19-33-586
6	6.625	0.280	5 5/8	19-33-587
8	8.625	0.219	7	
		0.322		19-12-443
10	10.750	0.365	8 1/2	19-33-259
12	12.750	0.375	10	19-33-260
16	16.000	0.375	12	19-33-605

18	18.000	0.250	13 1/2	19-33-588 (1)
20	20.000	0.375	15	19-33-589
24	24.000	0.375	17	19-33-590
30	30.000	0.375	22	19-33-591

Notes: (1) Y-60

Appendix D - Reducing Tees and Concentric Tees

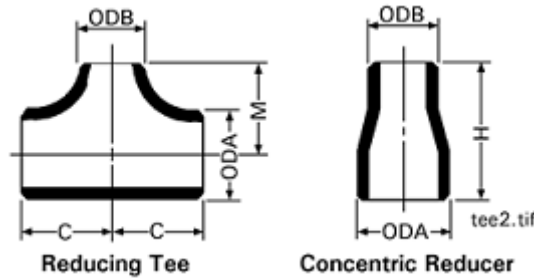

Reducing Tees and Concentric Tees - 35,000 psig SMYS							
Nominal Pipe Size (inches)	Outside Diameter ODA x ODB (inches)	Wall Thickness (inches)	Dimensions			Stock Code	
			C (inches)	M (inches)	H (inches)	Reducing	Concentric
1 x 3/4	1.315 x 1.050	0.133 x 0.113	1 1/2	1 1/2	2		19-33-138
1 1/4 x 3/4	1.660 x 1.050	0.140 x 0.113	1 7/8	1 7/8	2		19-08-556
1 1/4 x 1	1.660 x 1.315	0.140 x 0.133	1 7/8	1 7/8	2	19-33-235	19-33-139
2 x 3/4	2.375 x 1.050	0.154 x 0.113	2 1/2	1 3/4	3	19-33-239	19-33-142
		0.154 x 0.133	2 1/2	2	3	19-33-240	19-23-427
2 x 1	2.375 x 1.315	0.218 x 0.179	2 1/2	2	3		19-33-145
		0.154 x 0.140	2 1/2	2 1/4	3	19-23-124	19-08-558
2 x 1 1/4	2.375 x 1.900	0.154 x 0.145	2 1/2	2 3/8	3	19-23-612	19-33-141
3 x 2	3.500 x 2.375	0.216 x 0.154	3 3/8	3	3 1/2	19-33-245	19-33-148
		0.300 x 0.218	3 3/8	3	3 1/2		19-33-149
4 x 2	4.500 x 2.375	0.237 x 0.154	4 1/8	3 1/2	4	19-08-413	19-33-652
		0.337 x 0.218	4 1/8	3 1/2	4		19-33-152
4 x 3	4.500 x 3.500	0.237 x 0.216	4 1/8	3 7/8	4		19-12-254
6 x 2	6.625 x 2.375	0.280 x 0.154	5 5/8	4 3/4	5 1/2		19-33-155
6 x 3	6.625 x 3.500	0.280 x 0.216	5 5/8	4 7/8	5 1/2		19-33-156
6 x 4	6.625 x 4.500	0.280 x 0.237	5 5/8	5 4/8	5 1/2		19-33-653
8 x 4	8.625 x 4.500	0.322 x 0.237	7	6 1/8	6	19-23-131	19-33-159
8 x 6	8.625 x 6.625	0.322 x 0.280	7	6 5/8	6		19-08-565
10 x 4	10.750 x 4.500	0.365 x 0.237	8 1/2	7 1/4	7		19-33-161
10 x 6	10.750 x 6.625	0.365 x 0.280	8 1/2	7 5/8	7		19-33-162
10 x 8	10.750 x 8.625	0.365 x 0.322	8 1/2	8	7		19-33-163
12 x 10	12.750 x 10.750	0.500 x 0.500	10	9 1/2	8		

Reducing Tees and Concentric Tees - 52,000 psig SMYS

UNCONTROLLED IF PRINTED

Nominal Pipe Size (inches)	Outside Diameter ODA x ODB (inches)	Wall Thickness (inches)	Dimensions			Stock Code	
			C (inches)	M (inches)	H (inches)	Reducing	Concentric
4 x 2	4.500 x 2.375	0.237 x 0.154	4 1/8	3 1/2	4	19-33-585	19-33-691
		0.337 x 0.218	4 1/8	3 1/2	4		
4 x 3	4.500 x 3.500	0.237 x 0.216	4 1/8	3 7/8	4		
6 x 2	6.625 x 2.375	0.280 x 0.154	5 5/8	4 3/4	5 1/2	19-33-253	
6 x 3	6.625 x 3.500	0.280 x 0.216	5 5/8	4 7/8	5 1/2		
6 x 4	6.625 x 4.500	0.280 x 0.237	5 5/8	5 4/8	5 1/2	19-12-445	19-33-604
8 x 4	8.625 x 4.500	0.322 x 0.237	7	6 1/8	6		19-33-603
8 x 6	8.625 x 6.625	0.322 x 0.280	7	6 5/8	6	19-33-258	19-33-602
10 x 4	10.750 x 4.500	0.365 x 0.237	8 1/2	7 1/4	7	19-23-133	19-33-601
10 x 6	10.750 x 6.625	0.365 x 0.280	8 1/2	7 5/8	7		19-33-592
10 x 8	10.750 x 8.625	0.365 x 0.322	8 1/2	8	7		19-33-593
12 x 6	12.750 x 6.625	0.375 x 0.280	10	8 5/8	8		19-23-433
12 x 8	12.750 x 8.625	0.500 x 0.322	10	9	8		19-33-697
		0.375 x 0.322				19-33-261	19-23-434
12 x 10	12.750 x 10.750	0.375 x 0.365	10	9 1/2	8		19-33-595
14 x 12	14.000 x 12.750	0.375 x 0.375	11	10 5/8	13		19-33-596
16 x 6	16.00 x 6.625	0.375 x 0.280	12	10 3/8		19-23-628	
16 x 10	16.000 x 10.750	0.375 x 0.280	12	11 1/8	14		
		0.500 x 0.500					19-33-692
16 x 12	16.000 x 12.750	0.375 x 0.375	12	11 5/8	14		19-33-597
		0.500 x 0.500					19-33-700
18 x 12	18.000 x 12.750	0.375 x 0.375	13 1/2	12 5/8	15		19-33-598 (1)
18 x 16	18.000 x 16.000	0.375 x 0.375	13 1/2	13	15		19-33-599 (1)
20 x 16	20.000 x 16.000	0.500 x 0.500	15	14	20		19-33-702

Note: (1) Y-60

Appendix E - Caps

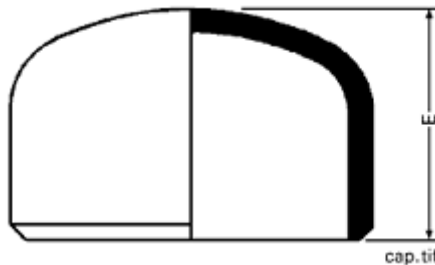

Weld Caps - 32,000 psig SMYS				
Nominal Pipe Size (inches)	Outside Diameter ODA (inches)	Wall Thickness (inches)	Dimension E (inches)	Stock Code
3/4	1.050	0.113	1 1/2	19 23 789
1	1.315	0.133	1 1/2	19 23 794

UNCONTROLLED IF PRINTED

1 1/4	1.660	0.140	1 1/2	19 23 796
1 1/2	1.900	0.145	1 1/2	19 23 010
2	2.375	0.154	1 1/2	19 15 155
	2.375	0.218	1 1/2	19 33 583
3	3.500	0.216	2	19 23 804
4	4.500	0.237	2 1/2	19-33-658
6	6.625	0.280	3 1/2	19 15 158
8	8.625	0.322	4	19 15 159
10	10.75	0.219	5	
		0.365		19 23 809
12	12.750	0.250	6	19 23 019
		0.375		19 23 813

Weld Caps - 52,000 psig SMYS				
Nominal Pipe Size (inches)	Outside Diameter ODA (inches)	Wall Thickness (inches)	Dimension E (inches)	Stock Code
4	4.500	0.237	2 1/2	19 33 573
6	6.625	0.280	3 1/2	19 33 574
8	8.750	0.322	4	19 33 575
10	10.750	0.250	5	19 33 576
12	12.750	0.250	6	19 23 812
14	14.000	0.250	6 1/2	19 33 577
16	16.000	0.312	7	19 33 579
		0.375		19 33 578
18	18.000	0.250	8	19 23 319 (1)
20	20.000	0.375	9	19 33 580
24	24.000	0.375	10 1/2	19 33 581
30	30.000	0.375	10 1/2	19 33 582

Note: (1) Y-60

Appendix F - Unions

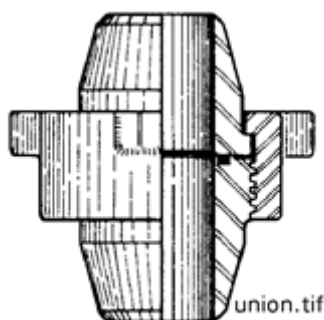

Huber-Yale Figure 300 Union

Butt Weld Union Figure 300 - 2500 psig

Size (inches)	Approx. Weight (lbs.)	Length (inches)	Color Identification		Stock Code	
			Sub Ends	Nut	Union	O-Ring
1	2 1/2	3 1/4	Pearl Gray	Green	19-83-155	29-64-870
2	8 3/4	5 1/8			19-83-151	29-64-871
3	15 7/8	5 1/2			19-83-152	29-64-872
4	25 1/2	5 3/4			19-83-153	
6	50	7 5/8			19-83-154	

Note: Figure 300 Unions employ an O-Ring

Appendix G - Quick Opening Closures



Yale Figure 500

All closures have a PAV bleed valve

QUICK OPENING CLOSURES						
Stock Code	Size	ANSI CL	Pressure Rating	Connection	Wall Thickness	Hinged
19 33 530	2"	300	740	Weld	0.154"	Vertical
19 33 534	2"	600	1480	Weld	0.154"	Vertical
19 33 532	4"	300	740	Weld	0.237"	Vertical
19 33 536	4"	600	1480	Weld	0.237"	Vertical
19 33 533	6"	300	740	Weld	0.280"	Vertical
19 33 537	6"	600	1480	Weld	0.280"	Vertical
19 33 569	8"	300	740	Weld	0.322"	Vertical
19 33 568	8"	600	1480	Weld	0.322"	Vertical

Appendix H - Weld Transition Fitting Specifications

Refer to [WELD 2.3 Appendix A](#) - Joining Unequal Steel Wall Pipe & Fittings

- Mat'l. Spec. _____
- A. Pipe size _____ in. OD Min. Yield _____ psi
 Max. Opr. Pres. _____ psi
- B. Std. end wall thickness _____ In. }
 C. Tapered end wall thickness _____ In. } Difference equals offset
- D. Bevel Std. $30^{\circ} \begin{smallmatrix} +5 \\ -0 \end{smallmatrix}$
- E. Taper cutback @ 14° Min. = $\frac{\text{Offset}}{.25} =$ _____ In.
 (Tan. $14^{\circ} = .24933$)
- F. Std. end to mate with:
 Description: _____
- G. Tapered end to mate with:
 Description: _____
 Material spec. _____
- H. Length: 12" minimum or 1 1/2 times nominal pipe diameter

Appendix I - Weld End Insulators

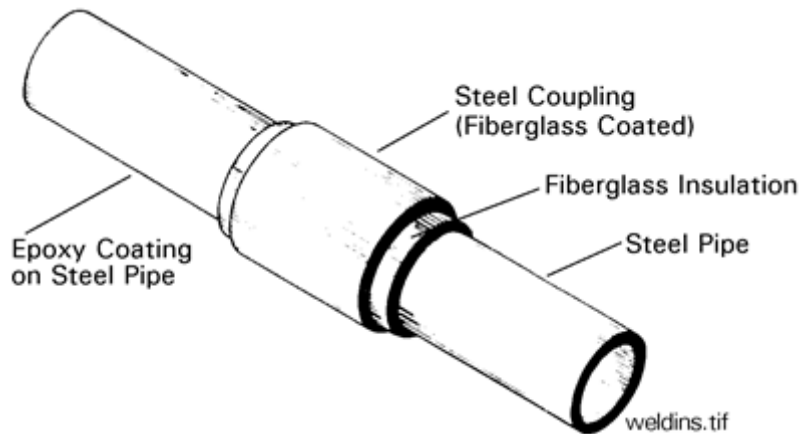

WELD END INSULATORS ANSI CLASS 300					
Stock Code	Size (inches)	Model	Wall Thickness (inches) (Note 1)	Length (inches)	Weight (lbs)
25 59 116	1/2	Kerotest WEI 7	0.109	16	1.50
		Kerotest Zunt	0.109	11-13/16	2.20
25 59 117	3/4	Kerotest WEI 7	0.113	19-1/2	2.75
		Kerotest Zunt	0.113	11-13/16	2.90
25 59 118	1-1/4	Kerotest WEI 7	0.140	19-1/2	6.25
		Kerotest Zunt	0.140	11-13/16	5.50
25 59 119	2	Kerotest WEI 7	0.154	21-5/8	10.50
		Kerotest Zunt	0.154	15-3/4	13.20
		PSI ElectroStop	0.154	27-1/2	13.20
25 59 120	3	Kerotest WEI 7	0.188	22-1/2	17.50
		Kerotest Zunt	0.188	19-11/16	26.40

UNCONTROLLED IF PRINTED

		PSI ElectroStop	0.226	27-1/2	25.50
25 59 121	4	Kerotest WEI 7	0.188	22-1/2	27.00
		Kerotest Zunt	0.188	19-11/16	30.80
		PSI ElectroStop	0.237	27-1/2	37.20
25 59 122	6	Kerotest WEI 7	0.218	22-3/4	62.00
		Kerotest Zunt	0.218	23-5/8	81.40
		PSI ElectroStop	0.280	27-1/2	68.20
25 59 123	8	Kerotest WEI 7	0.250	25	115.00
		Kerotest Zunt	0.250	23-5/8	125.40
		PSI ElectroStop	0.322	27-1/2	127.60
25 59 124	10	Kerotest WEI 7	0.307	27-1/2	198.00
		Kerotest Zunt	0.307	27-5/8	187.00
		PSI ElectroStop	0.365	31-1/2	202.80

Note (1): Wall thicknesses shown in the tables are manufacturer's standard insulator wall thicknesses which are kept in stock. Specific wall thicknesses other than those shown above can be requested with the understanding there may be a significant lead time.

STEEL PIPE

STLP 3.2 Reinforcing Saddles

1.0 Purpose

This document describes the requirements and design considerations for reinforcing saddles, regular and full-encirclement, approved for use at Ameren Illinois (AIC) and in accordance with 49 CFR §192.155.

2.0 Scope

This document addresses the following:

[3.0 Target Audience](#)

[4.0 General](#)

[5.0 Installation](#)

Appendices:

[Appendix A - Saddles](#)

3.0 Target Audience

- Gas Engineering
- Gas Field Personnel – Welders
- Gas Supervisors
- Gas Tech Engineering (GTE)
- Gas Storage Engineering (GSE)
- Gas Tech Services (GTS) Supervisors
- Gas Tech Services (GTS) Personnel
- Gas Storage Supervisors
- Gas Storage Field Operators
- Gas Construction Services Supervisors
- Contract Welders
- Welding Inspectors

4.0 General

- 4.1 Reinforcing saddles are **not** required when the maximum allowable operating pressure (MAOP) is less than 100 psig and the opening is 2" or smaller with a branch to header ratio less than 25%.
- 4.2 Regular type reinforcing saddles are required for MAOPs greater than 100 psig and when the branch to header ratio is between 25% and 50%.
- 4.3 Full encirclement reinforcing saddles are required for MAOPs greater than 100 psig and when the branch to header ratio is 50% or greater.

For pressure greater than 350 psig, contact Gas Tech Engineering.

- 4.4 Refer to Table 1 as a guide for choosing reinforcing saddles for MAOPs greater than 100 psig.

Table 1: Selection of Reinforcing Saddles for MAOPs Greater than 100 psig

Nominal Header	Nominal Branch
----------------	----------------

	1 1/4	2	3	4	6	8	10
2	F	F					
3	R	F	F				
4	R	F	F	F			
6	--	R	F	F	F		
8	--	R	R	F	F	F	
10	--	--	R	R	F	F	F
12	--	--	R	R	F	F	F
14	--	--	--	R	R	F	F
16	--	--	--	R	R	F	F
	--	Reinforcing not normally required.					
	R	Regular type reinforcing saddle required.					
	F	Full Encirclement reinforcing saddle required.					

- 4.5 Weldolets that meet ASME B31.8 requirements for reinforcement area are an approved substitute for both a regular and a full encirclement reinforcing saddle for all pressure ranges and all sizes and ratios of header and branches.
 - 4.5.1 Weldolets are designed so that they have enough area in the fitting itself to meet the requirements for extra reinforcement area that is not provided by the branch and header pipe walls.
 - 4.5.2 Weldolets must be selected according to the specifications and requirements set forth in the manufacturer's catalog.
 - 4.5.3 Weldolets may also be used on branches that do not require additional reinforcement as their shape allows for more efficient fluid flow.

5.0 Installation

Reinforcing saddles are not intended to retain internal pressure.

- 5.1 Regular and full encirclement saddles ([Appendix A](#)) are installed over a shaped nipple initially welded to the header piping.
- 5.2 Any required non-destructive testing (NDT) shall be performed on fitting welds prior to installing reinforcing saddles.
- 5.3 Regular Type Reinforcing Saddle
 - 5.3.1 A regular type reinforcing saddle is installed as follows ([Figure 1](#)):
 1. Weld shaped nipple to header piping.
 2. Weld reinforcing saddle to header piping with a full fillet weld.
 3. Weld reinforcing saddle to shaped nipple outlet with a full fillet weld.
 4. **Do not** weld vent hole close. Vent prevents gas build-up under the reinforcing saddle.
 5. Coat with an approved coating material. See [CORR 2.3](#) Coatings.

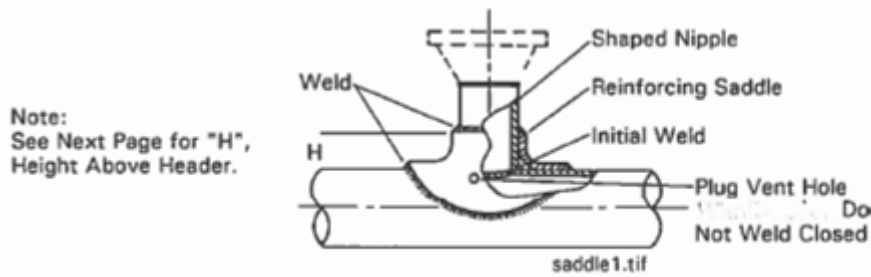

Figure 1: Regular Type Reinforcing Saddle - Typical Installation

5.4 Full Encirclement Reinforcing Saddle

5.4.1 A full encirclement reinforcing saddle is installed as follows ([Figure 2](#)):

1. Weld shaped nipple to header piping.
2. Clamp saddle in position and weld longitudinal seams. There should be an approximately equal progression of welding down each side seam until completion, i.e., make a pass down one side then down the other side. See [WELD 4](#) for approved In-Service Welding (IS) procedures and joint designs.
3. Weld full encirclement reinforcing saddle to the carrier pipe with a full fillet circumferential weld. Weld one end at a time and allow the weld to cool before welding the other end.
4. Weld full encirclement reinforcing saddle to shaped nipple outlet with a full fillet weld after the saddle end welds have cooled.
5. Do not weld vent hole closed. Vent prevents gas build-up under the reinforcing saddle.
6. Coat with an approved coating material. See [CORR 2.3](#) Coatings.

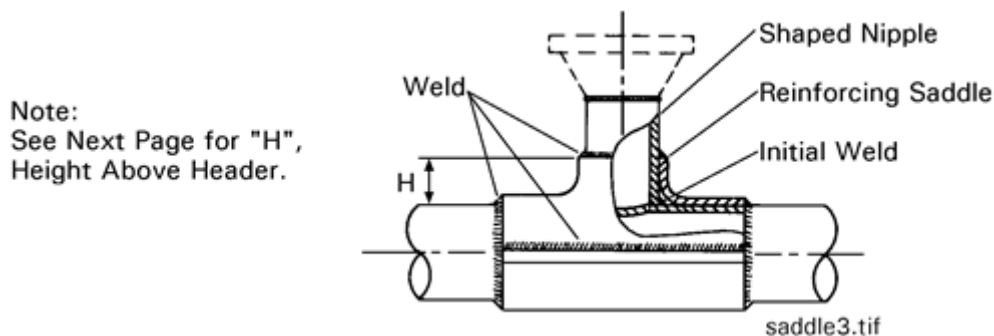

Figure 2: Full Encirclement Reinforcing Saddle - Typical Installation

End of Instructions.

Operator Qualification (OQ) Required?

YES

0801: Welding

0811: Visual Inspection of Welding and Welds

1051: Fit-Up of Weld Type Repair Sleeve

UNCONTROLLED IF PRINTED

Appendices

Appendix A - Saddles

Attachments

NONE.

Compliance Requirements

49 CFR §192.155 Welded branch connections.

Reference Documents

[CORR 2.3 Corrosion Control: Coatings](#)

[WELD 4 Welding: Forms and Reference Materials](#)

Document Rescission

STLP 3.2 Steel Pipe: Reinforcing Saddles, October 1, 2020.

Revision Notes

Location of Changes	Summary of Changes
Appendix A	Corrected dimension for 3" Saddle, 1933166, to 1-1/4"

Appendix A - Saddles

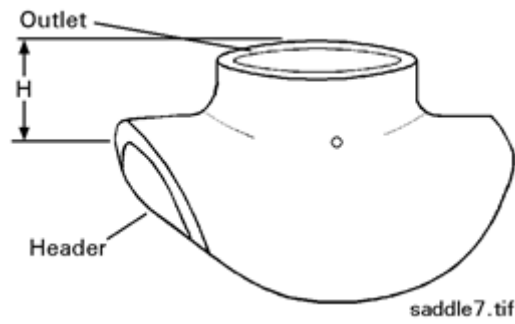

Regular Type Saddle			
Header (inches)	Outlet (inches)	H* (inches)	Stock No.
2	1 1/4	7/8	19 33 172
	2	1	19 33 169
3	1 1/4	7/8	19 33 166
	2	1	19 33 170
4	1 1/4	7/8	19 33 167
	2	1	19 33 171
	4	1 1/8	19 33 178
6	1 1/4	7/8	19 33 168
	2	1	19 33 174
	3	1	19 33 185
	4	1 1/8	19 33 179
	6	1 1/4	19 33 182
8	2	1	19 33 175
	4	1 1/8	19 33 180
	6	1 1/4	19 33 183
10	6	1 1/4	19 33 184
12	1	7/8	19 33 165
	2	1	19 33 177
	4	1 1/8	19 33 181
16	2	1	19 33 176

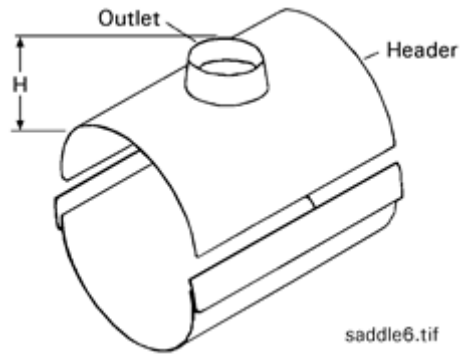

saddle6.tif

Full Encirclement Saddle			
Header (inches)	Outlet (inches)	H* (inches)	Stock No.
2	2	1	19 33 186
3	2	1	19 33 187
	3	1	19 33 189
4	2	1	19 33 188
	3	1	19 33 190
6	3	1	19 33 191
	6	1 1/4	19 33 196
8	4	1 1/8	19 33 194
	6	1 1/4	19 33 197
10	4	1 1/8	19 33 195
	8	1 5/8	19 33 199
12	6	1 1/4	19 33 198
	8	1 5/8	19 33 200

* "H" may vary between manufacturers

1.0 Purpose

This document describes the requirements for steel flanges and flange assembly, approved for use at Ameren Illinois (AIC) in accordance with 49 CFR §192.147.

2.0 Scope

This document addresses the following:

[3.0 Target Audience](#)

[4.0 General](#)

[5.0 Flange Assembly](#)

[6.0 Tightening Sequence](#)

Appendices:

[Appendix A - Weld Neck - Raised Face](#)

[Appendix B - Weld Neck - Flat Face](#)

[Appendix C - Screwed - Flat Face](#)

[Appendix D - Blind](#)

[Appendix E - Lap Joint](#)

[Appendix F - Flange Stud Bolts](#)

[Appendix G - Gaskets](#)

3.0 Target Audience

- Gas Engineering
- Gas Tech Engineering (GTE)
- Gas Storage Engineering (GSE)
- Gas Field Personnel
- Gas Supervisors
- Gas Tech Services (GTS) Supervisors
- Gas Tech Services (GTS) Personnel
- Gas Construction Services Supervisors
- Gas Storage Field Supervisors
- Gas Storage Field Operators

4.0 General

- 4.1 Flanges, due to additional stress requirements for their configurations and bolted connections, are entities which require separate consideration from other fittings for technical reasons.
- 4.2 Two types of weld neck flanges are available:
- 4.2.1 Regular double-taper type (ANSI B16.5) in sizes 1/2" to 24" nominal.
- 4.2.2 Single-taper type (MSS SP-44) in sizes 12" nominal and larger. Although material specifications and manufacturing processing are identical, the addition of metal in the weld neck area of the single-taper design favors their use on all hi-test line pipe installations 12" and larger.

- 4.3 Flanges installed in the AIC gas system are either iron or steel. Steel flanges may be referred to by any of the following designations. All have the same meaning: "Class 150" or "Series 15" or "A.S.A. 150" or "150 pound" or "150 lb".
- 4.4 Table 1 provides maximum allowable operating pressure for the various flanges.

Table 1: Maximum Allowable Operating Pressure for Flanges

Steel (ANSI B16.5) All Sizes		Iron (ANSI B16.1) Sizes 1 thru 12	
Class	Maximum Operating Pressure (psig)	Class	Maximum Operating Pressure (psig)
150	285	125	200
300	740	250	500
400	985	Contact Engineering for iron pipe sizes 14 thru 24 inch.	
600	1,480		
900	2,220		

MAOP rating for steel flanges decreases when flange temperature exceeds 100°F. MAOP rating for iron flanges decreases when flange temperature exceeds 150°F. Contact Div. Engineer, GTE or GSE for MAOP at higher temperatures.

- 4.5 Maximum operating pressure of a flange assembly is that of the weaker component.

Exercise care when assembling iron flanges to steel flanges to avoid breaking the relatively brittle iron flange.

- 4.5.1 Class 150 steel flanges may be bolted to Class 125 iron flanges.
- 4.5.2 Class 300 steel flanges may be bolted to Class 250 iron flanges.
- 4.5.3 Flanged end iron or semi-steel valves may have ratings higher than those given above for iron flanges. If valves are rated higher than the iron flanges shown above, bolt to steel flange.
- 4.6 See the following Appendices for stock codes for approved flanges, flange stud bolts and gaskets.
 - 4.6.1 [Appendix A](#) - Weld Neck - Raised Face
 - 4.6.2 [Appendix B](#) - Weld Neck - Flat Face
 - 4.6.3 [Appendix C](#) - Screwed - Flat Face
 - 4.6.4 [Appendix D](#) - Blind
 - 4.6.5 [Appendix E](#) - Lap Joint
 - 4.6.6 [Appendix F](#) - Flange Stud Bolts
 - 4.6.7 [Appendix G](#) - Gaskets

5.0 Flange Assembly

- 5.1 When assembling the flanges, ensure that the flange gasket seating surface and gasket are free of dirt, metal shavings, weld slag or any other debris which could cause an uneven seat.
- 5.2 Line up the gasket evenly with the inside bore of the flange. No portion of the gasket should extend into the bore of the flange.
- 5.3 The size and length bolts or stud bolts are dependent on the flange type and pressure class. The tables in [Appendix F](#), Flange Stud Bolts, provide the size and minimum bolt length for pressure class 150, 300 and 600 and flange sizes through 12 inch.
 - 5.3.1 For flange sizes not listed, the bolt sizes and minimum length may be found in Pipe Fitters Handbook, flange manufacturer's instructions, or by contacting Gas Engineering, GTE, or GSE.
- 5.4 The bolts or stud bolts shall extend completely through the nuts. Where clearance or safety is an issue, avoid excessive bolt protrusion. **Do not** use washers to reduce the protrusion.
- 5.5 Tighten bolts, ensuring that flange faces are parallel and the bolts are tightened uniformly. Refer to [Section 6.0](#) Tightening Sequence, for the correct sequential order for tightening bolts, depending on the number of bolts.
 - 5.5.1 On the first pass, lightly tighten the first bolt then move directly across or 180° for the second bolt, then move ¼ turn around the circle or 90° for the third bolt and directly across for the fourth. Continue this sequence until all bolts are tightened.
 - 5.5.2 **Do not** snug up bolts on the first pass. This can tilt the flanges out of a parallel seat.
 - 5.5.3 When using an impact wrench, set the wrench at about ½ the final torque for the first pass.

6.0 Tightening Sequence

Follow the tightening sequences below when assembling bolted flange connections.

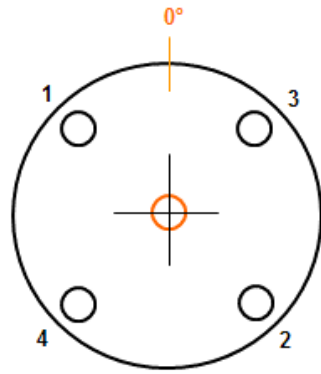

4 Bolts
Sequential Order
1-2
3-4

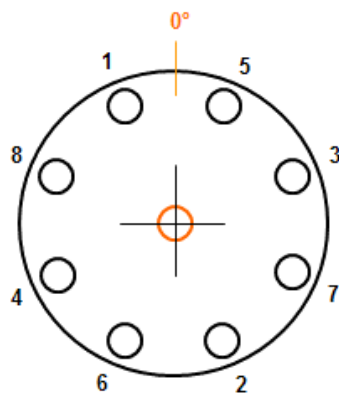

8 Bolts
Sequential Order
1-2
3-4
5-6
7-8

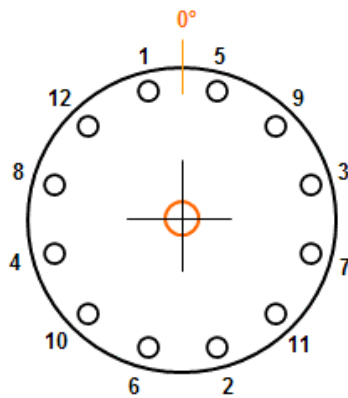

12 Bolts
Sequential Order
1-2
3-4
5-6
7-8
9-10
11-12

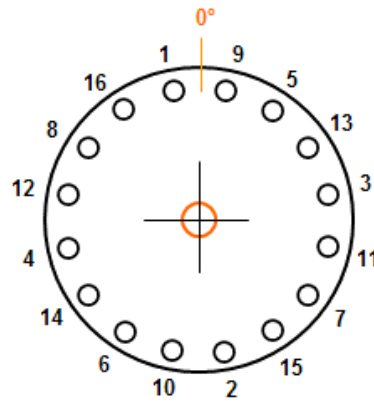

16 Bolts
Sequential Order

- 1-2
- 3-4
- 5-6
- 7-8
- 9-10
- 11-12
- 13-14
- 15-16

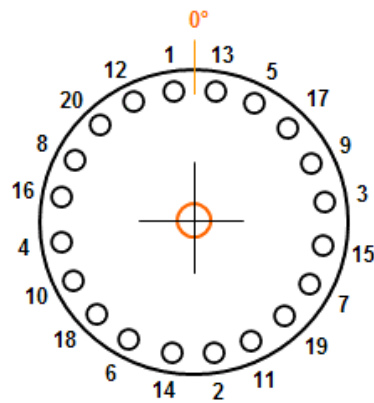

20 Bolts
Sequential Order

- 1-2
- 3-4
- 5-6
- 7-8
- 9-10
- 11-12
- 13-14
- 15-16
- 17-18
- 19-20

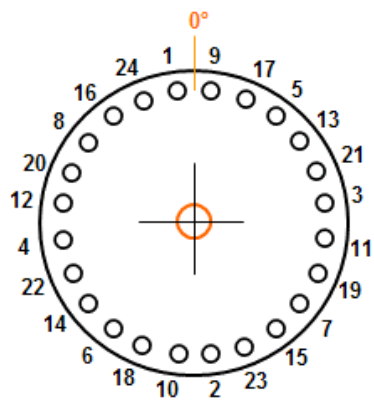

24 Bolts
Sequential Order

- 1-2
- 3-4
- 5-6
- 7-8
- 9-10
- 11-12
- 13-14
- 15-16
- 17-18
- 19-20
- 21-22
- 23-24

End of Instructions.

Operator Qualification (OQ) Required?

NO.

Appendices

UNCONTROLLED IF PRINTED

[Appendix A - Weld Neck - Raised Face](#)

[Appendix B - Weld Neck - Flat Face](#)

[Appendix C - Screwed - Flat Face](#)

[Appendix D - Blind](#)

[Appendix E - Lap Joint](#)

[Appendix F - Flange Stud Bolts](#)

[Appendix G - Gaskets](#)

Attachments

NONE.

Compliance Requirements

49 CFR §192.147 Flanges and flange accessories.

Reference Documents

ASME/ANSI B16.1, Gray Iron Pipe Flanges and Flanged Fittings: Classes 25, 125, and 250

ASME/ANSI B16.5, Pipe Flanges and Flanged Fittings: NPS 1/2 through NPS 24 Metric/Inch Standard

MSS SP-44, Steel Pipeline Flanges

Pipe Fitters Handbook

Document Rescission

STLP 3.3 Steel Pipe: Flanges, October 1, 2020.

Revision Notes

Location of Changes	Summary of Changes
Appendix G-3 – Insulating Gaskets for Steel Flanges and Fittings	Corrected Stock Codes in table. New Stock Codes for the 1-1/4" Class 600, 2" Class 300 and 3" Class 300 all Type F are for Insulating Gasket Kits.

Appendix A - Weld Neck - Raised Face

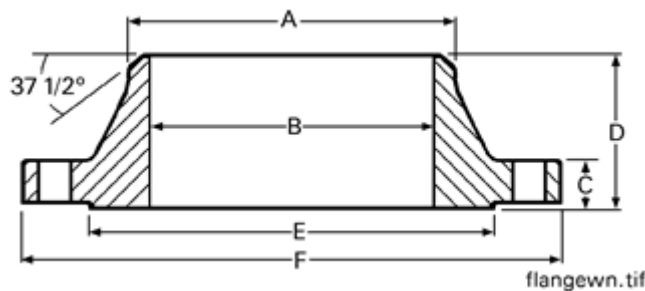

150 Lb. Raised Face Weld Neck Flanges								
Size (Inches)	A (Inches)	B (Inches)	C (Inches)	D (Inches)	E (Inches)	F (Inches)	No. of Holes	Weight (lb)

UNCONTROLLED IF PRINTED

1 1/4	1.66	1.38	5/8	2 1/4	2 1/2	4 5/8	4	2 1/2
2	2.38	2.07	3/4	2 1/4	3 5/8	6	4	6
3	3.50	3.07	15/16	2 3/4	5	7 1/2	4	11 1/2
4	4.50	4.03	15/16	3	6 3/16	9	8	16 1/2
6	6.63	6.07	1	3 1/2	8 1/2	11	8	26
8	8.63	7.98	1 1/8	4	10 5/8	13 1/2	8	42
10	10.75	10.02	1 3/16	4	12 3/4	16	12	54

300 Lb. Raised Face Weld Neck Flanges								
Size (Inches)	A (Inches)	B (Inches)	C (Inches)	D (Inches)	E (Inches)	F (Inches)	No. of Holes	Weight (lb)
1 1/4	1.66	1.38	3/4	2 9/16	2 1/2	5 1/4	4	5
2	2.38	2.07	7/8	2 3/4	3 5/8	6 1/2	8	8
3	3.50	3.07	1 1/8	3 1/8	5	8 1/4	8	18
4	4.50	4.03	1 1/4	3 3/8	6 3/16	10	8	26 1/2
6	6.63	6.07	1 7/16	3 7/8	8 1/2	12 1/2	12	45
8	8.63	7.98	1 5/8	4 3/8	10 5/8	15	12	69
10	10.75	10.02	1 7/8	4 5/8	12 3/4	17 1/2	16	100

600 Lb. Raised Face Weld Neck Flanges								
Size (Inches)	A (Inches)	B (Inches)	C (Inches)	D (Inches)	E (Inches)	F (Inches)	No. of Holes	Weight (lbs.)
1 1/4	1.66	1.28	1 1/16	2 7/8	2 1/2	5 1/4	4	5 1/2
2	2.38	1.94	1 1/4	3 1/8	3 5/8	6 1/2	8	10
3	3.50	2.90	1 1/2	3 1/2	5	8 1/4	8	18
4	4.50	3.83	1 3/4	4 1/4	6 3/16	10 3/4	8	37
6	6.63	5.75	2 1/8	4 7/8	8 1/2	14	12	73
8	8.63	7.63	2 7/16	5 1/2	10 5/8	16 1/2	12	112
10	10.75	9.75	2 3/4	6 1/4	12 3/4	20	16	189

Appendix B - Weld Neck - Flat Face

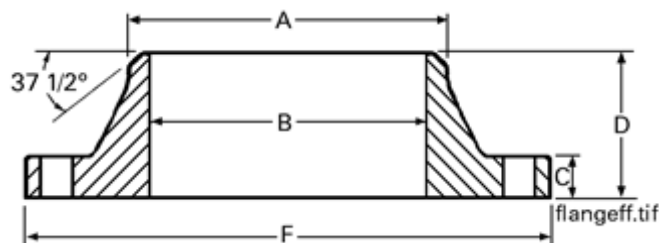

150 Lb. Flat Faced Weld Neck Flanges								
Size (Inches)	A (Inches)	B (Inches)	C (Inches)	D (Inches)	F (Inches)	No. of Holes	Weight (lb)	
1 1/4	1.66	1.38	9/16	2 3/16	4 5/8	4	2 1/2	
2	2.38	2.07	11/16	2 7/16	6	4	6	
3	3.50	3.07	7/8	2 11/16	7 1/2	4	11 1/2	

UNCONTROLLED IF PRINTED

4	4.50	4.03	7/8	2 15/16	9	8	16 1/2
6	6.63	6.07	15/16	3 7/16	11	8	26
8	8.63	7.98	1 1/16	3 15/16	13 1/2	8	42

Appendix C - Screwed - Flat Face



125 Lb. Flat Faced Weld Neck Flanges					
Size (Inches)	A (Inches)	B (Inches)	C (Inches)	D (Inches)	No. of Holes
2	6	5/8	1	4 3/4	4

Appendix D - Blind

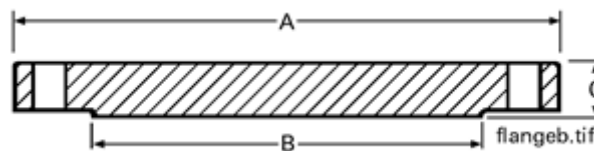

150 Lb. Blind Flanges					
Size (Inches)	A (Inches)	B (Inches)	C (Inches)	No. of Holes	Weight (lb)
1 1/4	4 5/8	2 1/2	5/8	4	3
2	6	3 5/8	3/4	4	4
3	7 1/2	5	15/16	4	9
4	9	6 3/16	15/16	8	17
6	11	8 1/2	1	8	27
8	13 1/2	10 5/8	1 1/8	8	47
10	16	12 3/4	1 3/16	12	67

300 Lb. Blind Flanges					
Size (Inches)	A (Inches)	B (Inches)	C (Inches)	No. of Holes	Weight (lb)
1 1/4	5 1/4	2 1/2	3/4	4	6
2	6 1/2	3 5/8	7/8	8	8
3	8 1/4	5	1 1/8	8	16
4	10	6 3/16	1 1/4	8	28
6	12 1/2	8 1/2	1 7/16	12	48
8	15	10 5/8	1 5/8	12	79
10	17 1/2	12 3/4	1 7/8	16	122

600 Lb. Blind Flanges					
-----------------------	--	--	--	--	--

Size (Inches)	A (Inches)	B (Inches)	C (Inches)	No. of Holes	Weight (lb)
1 1/4	5 1/4	2 1/2	13/16	4	6
2	6 1/2	3 5/8	1	8	10
3	8 1/4	5	1 1/4	8	20
4	10 3/4	6 3/16	1 1/2	8	41
6	14	8 1/2	1 7/8	12	86
8	16 1/2	10 5/8	2 3/16	12	139
10	20	12 3/4	2 1/2	16	231

Appendix E - Lap Joint

E-1. Flange

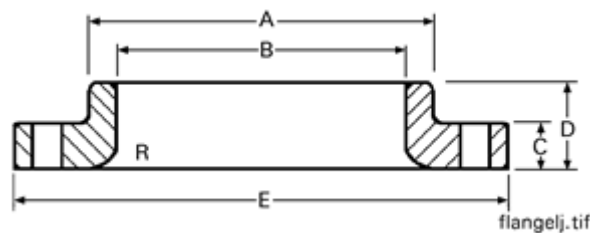

150 Lb. Lap Joint Flanges								
Size (Inches)	A (Inches)	B (Inches)	C (Inches)	D (Inches)	E (Inches)	R (Inches)	No. of Holes	Weight (lb)
1 1/4	2 5/16	1.72	5/8	13/16	4 5/8	4 5/8	4	2 1/2
2	3 1/16	2.46	3/4	1	6	5/16	4	5
3	4 1/4	3.60	15/16	1 3/16	7 1/2	3/8	4	9
4	5 5/16	4.60	15/16	1 5/16	9	7/16	8	12
6	7 9/16	6.75	1	1 9/16	11	1/2	8	18

300 Lb. Lap Joint Flanges								
Size (Inches)	A (Inches)	B (Inches)	C (Inches)	D (Inches)	E (Inches)	R (Inches)	No. of Holes	Weight (lb)
1 1/4	2 1/2	1.72	3/4	1 1/16	5 1/4	3/16	4	4 1/2
2	3 5/16	2.46	7/8	1 5/16	6 1/2	5/16	8	7
3	4 5/8	3.60	1 1/8	1 11/16	8 1/4	3/8	8	14 1/2
4	5 3/4	4.60	1 1/4	1 7/8	10	7/16	8	24
6	8 1/8	6.75	1 7/16	2 1/16	12 1/2	1/2	12	38

600 Lb. Lap Joint Flanges								
Size (Inches)	A (Inches)	B (Inches)	C (Inches)	D (Inches)	E (Inches)	R (Inches)	No. of Holes	Weight (lbs.)
1 1/4	2 1/2	1.72	13/16	1 1/8	5 1/4	3/16	4	4 1/2
2	3 5/16	2.46	1	1 7/16	6 1/2	5/16	8	8
3	4 5/8	3.60	1 1/4	1 13/16	8 1/4	3/8	8	14
4	6	4.60	1 1/2	2 1/8	10 3/4	7/16	8	31

UNCONTROLLED IF PRINTED

6	8 3/4	6.75	1 7/8	2 5/8	14	1/2	12	78
---	-------	------	-------	-------	----	-----	----	----

E-2. Stub Ends

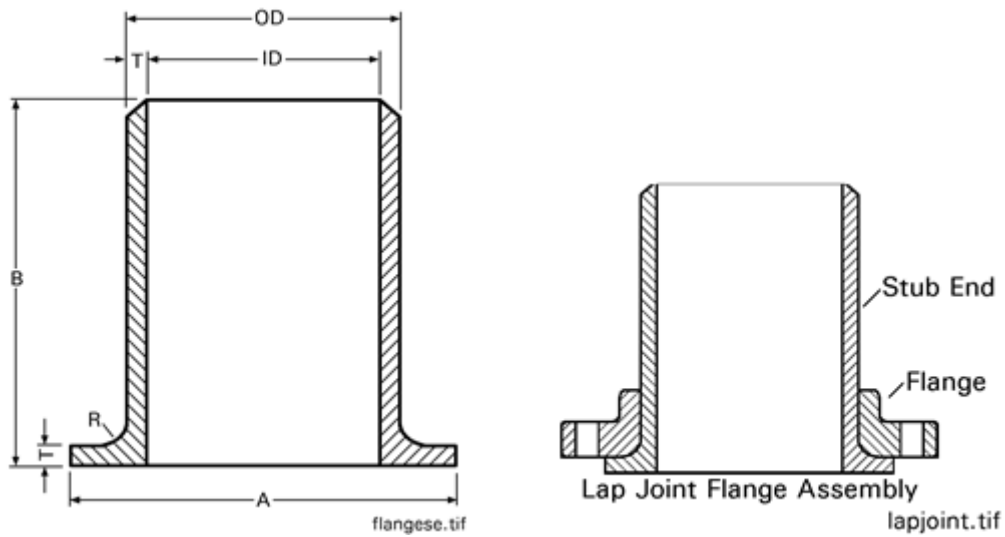

Standard Weight Lap Joint Stub Ends							
Size (Inches)	A (Inches)	B (Inches)	OD (Inches)	ID (Inches)	R (Inches)	Wall/Lap Thickness (T) (Inches)	Weight (lb)
1 1/4	2 1/2	4	1.660	1.380	3/16	0.140	1
2	3 5/8	6	2.375	2.067	5/16	0.154	2 1/4
3	5	6	3.500	3.068	3/8	0.216	4 3/4
4	6 3/16	6	4.500	4.026	7/16	0.237	7 1/4
6	8 1/2	8	6.625	6.065	1/2	0.280	15 1/2

Extra Strong Lap Joint Stub Ends							
Size (Inches)	A (Inches)	B (Inches)	OD (Inches)	ID (Inches)	R (Inches)	Wall/Lap Thickness (T) (Inches)	Weight (lb)
1 1/4	2 1/2	4	1.660	1.278	3/16	0.191	1 1/2
2	3 5/8	6	2.375	1.939	5/16	0.218	3
3	5	6	3.500	2.900	3/8	0.300	6 3/4
4	6 3/16	6	4.500	3.826	7/16	0.337	9 1/2
6	8 1/2	8	6.625	5.761	1/2	0.432	21 1/2

Appendix F - Flange Stud Bolts

F-1. Non-insulated

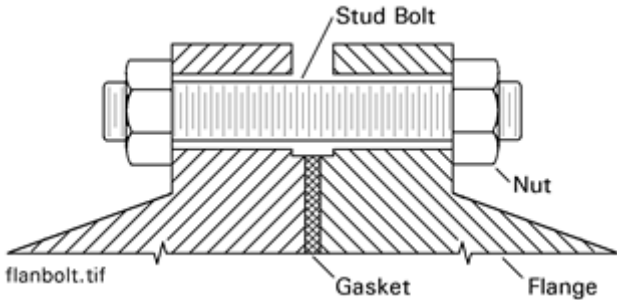

ANSI 150 - Raised/Flat Face, Non-insulated			
Flange Size (Inches)	Stud Bolt Size FTF (Inches)	No. of Holes	Stud Bolt w/2 Nuts (PTFE Coated)
3/4	1/2 x 2-1/2	4	21-74-456
1	1/2 x 2-1/2	4	21-74-456
1-1/4	1/2 x 2-3/4	4	21-74-457
1-1/2	1/2 x 2-3/4	4	21-74-457
2	5/8 x 3-1/4	4	21-74-419
3	5/8 x 3-1/2	4	21-74-420
4	5/8 x 3-1/2	8	21-74-420
6	3/4 x 4	8	21-74-422
8	3/4 x 4-1/4	8	21-74-423
10	7/8 x 4-1/2	12	21-74-427
12	7/8 x 4-3/4	12	21-74-428
14	1 x 5-1/4	12	-
16	1 x 5-1/4	16	-
18	1-1/8 x 5-3/4	16	-
20	1-1/8 x 6-1/4	20	-
24	1-1/4 x 6-3/4	20	-

ANSI 300 - Raised/Flat Face, Non-insulated			
Flange Size (Inches)	Stud Bolt Size FTF (Inches)	No. of Holes	Stud Bolt w/2 Nuts (PTFE Coated)
3/4	5/8 x 3	4	21-74-502
1	5/8 x 3	4	21-74-502
1-1/4	5/8 x 3-1/4	4	21-74-419
1-1/2	3/4 x 3-1/2	4	21-96-118
2	5/8 x 3-1/2	8	21-74-420
3	3/4 x 4-1/4	8	21-74-423
4	3/4 x 4-1/2	8	21-74-424
6	3/4 x 4-3/4	12	21-74-425
8	7/8 x 5-1/2	12	21-74-429
10	1 x 6-1/4	16	21-74-431
12	1-1/8 x 6-3/4	16	21-74-433
14	1-1/8 x 7	20	21-74-478
16	1-1/4 x 7-1/2	20	21-74-490
18	1-1/4 x 7-3/4	24	21-74-489
20	1-1/4 x 8	24	21-74-484
24	1-1/2 x 9	24	21-74-487

UNCONTROLLED IF PRINTED

ANSI 600 - Raised/Flat Face, Non-insulated			
Flange Size (Inches)	Stud Bolt Size FTF (Inches)	No. of Holes	Stud Bolt w/2 Nuts (PTFE Coated)
3/4	5/8 x 3-1/2	4	21-74-420
1	5/8 x 3-1/2	4	21-74-420
1-1/2	3/4 x 4-1/4	4	21-74-423
2	5/8 x 4-1/4	8	21-74-421
3	3/4 x 5	8	21-74-426
4	7/8 x 5-3/4	8	21-74-430
6	1 x 6-3/4	12	21-74-432
8	1-1/8 x 7-1/2	12	21-74-434
10	1 1/4 x 8-1/2	16	21-74-488
12	1-1/4 x 8-3/4	20	21-74-435
14	1-3/8 x 9-1/4	20	21-74-476
16	1-1/2 x 10	20	21-74-485
18	1-5/8 x 10-3/4	20	21-74-468
20	1-5/8 x 11-1/4	24	21-74-469
24	1-7/8 x 13	24	21-74-467

F-2. Insulated

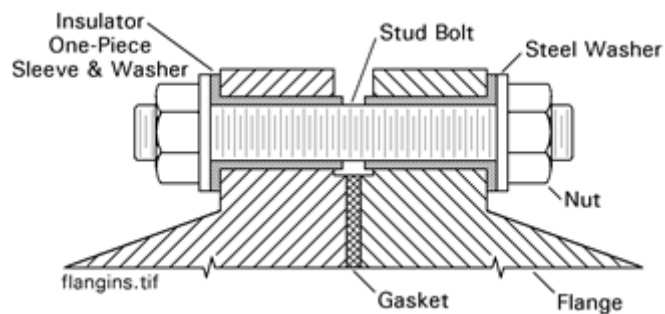

ANSI 150 - Raised/Flat Face, Insulated		
Stud Bolt Size FTF (Inches)	No. of Holes	Stud Bolt w/2 Nuts (PTFE Coated)
1/2 x 3-1/2	4	21-74-458
1/2 x 3-1/2	4	21-74-458
1/2 x 3-3/4	4	21-74-459
1/2 x 3-3/4	4	21-74-459
5/8 x 4-1/4	4	21-74-421
5/8 x 4-1/2	4	21-74-504
5/8 x 4-1/2	8	21-74-504
3/4 x 5	8	21-74-426
3/4 x 5-1/4	8	21-74-453
7/8 x 5-1/2	12	21-74-429
7/8 x 5-3/4	12	21-74-430
1 x 6-1/4	12	21-74-431
1 x 6-1/4	16	21-74-431
1-1/8 x 6-3/4	16	21-74-433
1-1/8 x 7-1/4	20	-
1-1/4 x 7-3/4	20	21-74-489

ANSI 300 - Raised/Flat Face, Insulated			
Flange Size (Inches)	Stud Bolt Size FTF (Inches)	No. of Holes	Stud Bolt w/2 Nuts (PTFE Coated)
3/4	5/8 x 4	4	21-74-505
1	5/8 x 4	4	21-74-505
1-1/4	5/8 x 4-1/4	4	21-74-421
1-1/2	3/4 x 4-1/2	4	21-74-424
2	5/8 x 4-1/2	8	21-74-504
3	3/4 x 5-1/4	8	21-74-453
4	3/4 x 5-1/2	8	21-74-452
6	3/4 x 5-3/4	12	21-74-454
8	7/8 x 6-1/2	12	21-74-500
10	1 x 7-1/4	16	21-74-492
12	1-1/8 x 7-3/4	16	21-74-480
14	1-1/8 x 8	20	21-74-479
16	1-1/4 x 8-1/2	20	21-74-488
18	1-1/4 x 8-3/4	24	21-74-435
20	1-1/4 x 9	24	21-74-499
24	1-1/2 x 10	24	21-74-485

UNCONTROLLED IF PRINTED

ANSI 600 - Raised/Flat Face, Insulated			
Size (Inches)	Stud Bolt Size (Inches)	No. of Holes	Stud Bolt w/2 Nuts (PTFE Coated)
3/4	5/8 x 4-1/2	4	21-74-504
1	5/8 x 4-1/2	4	21-74-504
1-1/4	5/8 x 4-3/4	4	-
1-1/2	3/4 x 5-1/4	4	21-74-453
2	5/8 x 5-1/4	8	21-74-461
3	3/4 x 6	8	21-96-122
4	7/8 x 6-3/4	8	21-74-482
6	1 x 7-3/4	12	21-74-493
8	1-1/8 x 8-1/2	12	21-74-501
10	1 1/4 x 9-1/2	16	21-74-498
12	1-1/4 x 9-3/4	20	21-74-481
14	1-3/8 x 10-1/4	20	21-74-473
16	1-1/2 x 11	20	21-74-486
18	1-5/8 x 11-3/4	20	21-74-470
20	1-5/8 x 12-1/4	24	21-74-471
24	1-7/8 x 14	24	21-74-466

Appendix G - Gaskets

G-1. Ring Gaskets for Raised Face Flanges and Fittings (Steel and Cast Iron)

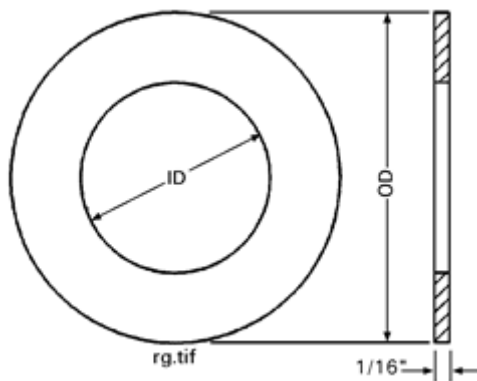

Nominal Pipe Size (Inches)	150 Lb. Steel or 125 lb. Cast Iron		300 Lb. Steel or 250 Lb. Cast Iron		600 Lb. Steel*	
	ID (Inches)	OD (Inches)	ID (Inches)	OD (Inches)	ID (Inches)	OD (Inches)
3/4	1 1/16	2 1/4	1 1/16	2 5/8	1 1/16	2 5/8
1	1 5/16	2 5/8	1 5/16	2 7/8	1 5/16	2 7/8
1 1/4	1 21/32	2	1 21/32	3 1/4	1 21/32	3 1/4
1 1/2	1 29/32	3 3/8	1 29/32	3 3/4	1 29/32	3 3/4
2	2 3/8	4 1/8	2 3/8	4 3/8	2 3/8	4 3/8
3	3 1/2	5 3/8	3 1/2	5 7/8	3 1/2	5 7/8
4	4 1/2	6 7/8	4 1/2	7 1/8	4 1/2	7 5/8
5	5 9/16	7 3/4	5 9/16	8 1/2	5 9/16	9 1/2

UNCONTROLLED IF PRINTED

6	6 5/8	8 3/4	6 5/8	9 7/8	6 5/8	10 1/2
8	8 5/8	11	8 5/8	12 1/8	8 5/8	12 5/8
10	10 3/4	13 3/8	10 3/4	14 1/4	10 3/4	15 3/4
12	12 3/4	16 1/8	12 3/4	16 5/8	12 3/4	18
14	14	17 3/4	14	19 1/8	14	19 3/8
16	16	20 1/4	16	21 1/4	16	22 1/4
18	18	21 5/8	18	23 1/2	18	24 1/8

* Do not use when pressurizing above 1200 psig.

Note: Gaskets are made from a non-asbestos compressed glass fiber reinforced material. Do not use jointing compounds with gaskets. Such compounds may adversely affect the life of the gasket.

G-2. Full-Face Gaskets for Flat-Face Flanges and Fittings (Steel and Cast Iron)

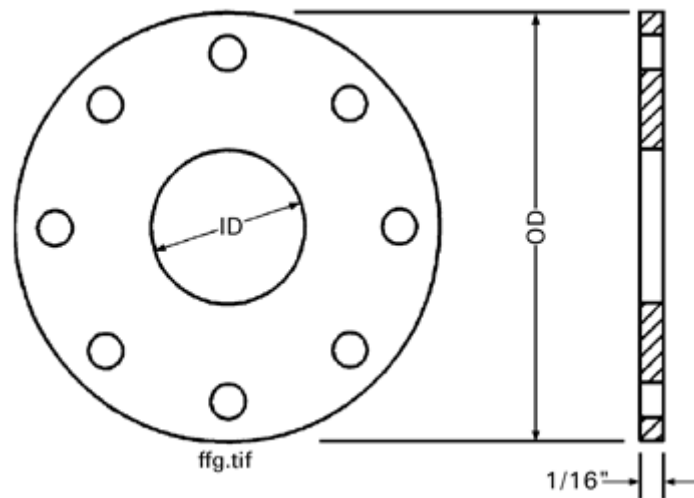

Nominal Pipe Size (Inches)	150 Lb. Steel or 125 lb. Cast Iron	
	ID (Inches)	OD (Inches)
3/4	1 1/16	3 7/8
1	1 5/16	4 1/4
1 1/4	1 21/32	4 5/8
1 1/2	1 29/32	5
2	2 3/8	6
3	3 1/2	7 1/2
4	4 1/2	9
5	5 9/16	10
6	6 5/8	11
8	8 5/8	13 1/2
10	10 3/4	16
12	12 3/4	19

Note: Gaskets are made from a non-asbestos compressed glass fiber reinforced material. Do not use jointing compounds with gaskets. Such compounds may adversely affect the life of the gasket.

G-3. Insulating Gaskets for Steel Flanges and Fittings

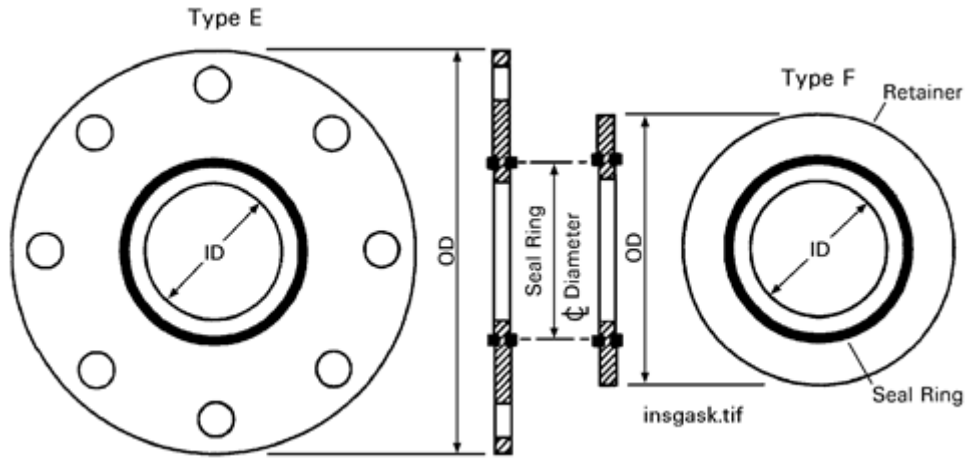

Nominal Pipe Size (Inches)	Stock No.		
	Type E Class 150	Type F Class 300	Type F Class 600
1 1/4	29 51 932	29 64 857	24-57-681*
2	29 51 933	24-57-674*	29 64 858
3	29 51 934	24-57-675*	29 64 859
4	29 51 935	29 51 940	29 64 864
6	29 51 936	29 64 860	29 64 865
8	29 51 937	29 64 861	29 64 866
10	29 51 938	29 64 862	29 64 867
12	29 51 939	29 64 863	29 64 868

* Stock Codes are for insulating kits

STEEL PIPE

October 1, 2022

STLP 4 Forms and Reference Materials

Click on the links below to open the documents.

References

1. [Huskie PS-62B Operations Manual](#)
2. [Huskie PS-75 Operating Instructions](#)
3. [Footage C170-A2 Owner's Manual](#)
4. [Regent Model 5045T Operation Manual](#)
5. [Regent Model 5230T Operation Manual](#)

End of Section.

Document Rescission

NONE

Revision Notes

Location of Changes	Summary of Changes
Not Applicable	This is a new document

TAPS-Tapping and Stopping

TAPPING AND STOPPING

October 1, 2022

TAPS 0 Table of Contents

[TAPS 1 Tapping and Stopping: Requirements](#)

Section 1.0 Purpose

Section 2.0 Scope

Section 3.0 Target Audience

Section 4.0 General

Section 5.0 Equipment

Section 6.0 Planning Requirements

Section 7.0 Pre-Job Conference

Section 8.0 Identification of Pipe Before Tapping

Section 9.0 Gauge, Blow-down, and By-pass Fittings

Section 10.0 Testing

Section 11.0 Completion of Tapping/Stopping Operation

Operator Qualification (OQ)

Appendices

Appendix A - Tapping Request Form

Appendix B - Drilling and Stopping Machines Typical, Images

Appendix C - Testing Consideration Tapping / Stopping Operation

Compliance Requirements

Reference Documents

Document Rescission

[TAPS 2.1 Tapping and Stopping: Dresser Meter Valve Changer](#)

Section 1.0 Purpose

Section 2.0 Scope

Section 3.0 Target Audience

Section 4.0 General

Section 5.0 Standard Pipe Stop Changer

Section 6.0 Meter Riser Stop Changer (5/8" O.D. Tubing)

Operator Qualification (OQ)

UNCONTROLLED IF PRINTED

Appendices

Appendix A - Dresser Stop Changer Image

Compliance Requirements

Reference Documents

Document Rescission

TAPS 2.2 Tapping and Stopping: Mueller NO-BLOW Valve Changer

Section 1.0 Purpose

Section 2.0 Scope

Section 3.0 Target Audience

Section 4.0 General

Section 5.0 Models

Section 6.0 NO-BLOW Equipment

Section 7.0 Preparing the Plugging Unit

Section 8.0 Assemble Plugging Unit to Meter Valve

Section 9.0 Attach Safety Clamp to Pipe

Section 10.0 Insert and Expand Rubber Plug

Section 11.0 Remove Old Valve

Section 12.0 Rethread the Pipe

Section 13.0 Install New Meter Valve

Section 14.0 Relax Rubber Plug and Remove Equipment

Section 15.0 Replacing Rubber Plug

Operator Qualification (OQ)

Appendices

Appendix A - Mueller NO-BLO Valve Changers

Appendix B - Mueller Valve Changer Images by Model

Appendix C - Mueller Plugging Units

Appendix D - Mueller Plugging Equipment Images

Compliance Requirements

Reference Documents

Document Rescission

TAPS 2.3 Tapping and Stopping: Mueller AUTOPERF Tee

Section 1.0 Purpose

Section 2.0 Scope

Section 3.0 Target Audience

Section 4.0 General

UNCONTROLLED IF PRINTED

Section 5.0 Views of Tee

Section 6.0 Maximum Pipe Wall Thickness for AUTOPERF Tee

Section 7.0 Installation Instructions

Operator Qualification (OQ)

Compliance Requirements

Reference Documents

Document Rescission

TAPS 2.4 Tapping and Stopping: Mueller Tapping & Stopping Procedure

Section 1.0 Purpose

Section 2.0 Scope

Section 3.0 Target Audience

Section 4.0 General

Section 5.0 Tapping Operation

Section 6.0 Stopping Operation

Section 7.0 Completion Operation

Operator Qualification (OQ)

Appendices

Appendix A - Mueller Stopper Fittings

A-1 Low-Pressure Line Stopper Fitting

A-2 Service Line Stopper Fitting

A-3 Line Stopper Fittings

A-4 Mueller Bottom-Out Line Stopper Fittings

Appendix B - Mueller Tees

B-1 Service Tees

B-2 Service Stop Tees

B-3 Curb Stop Tees

Appendix C - Mueller "Save-A-Valve" Drilling Nipple

Appendix D - Mueller Pig Plug / Line Stopper Fitting Insert

Compliance Requirements

Reference Documents

Document Rescission

TAPS 2.5 Tapping and Stopping: T.D. Williamson Tapping & Stopping Procedure

Section 1.0 Purpose

Section 2.0 Scope

UNCONTROLLED IF PRINTED

Section 3.0 Target Audience

Section 4.0 General

Section 5.0 Tapping Operation

Section 6.0 Stopping Operation

Section 7.0 Completion Operation

Operator Qualification (OQ)

Appendices

Appendix A - SHORTSTOPP Welding Fitting

Appendix B - SHORTSTOPP 3-Way Tee

Appendix C - SHORTSTOPP Spherical 3-Way Tee (Standard and 300D)

Appendix D - SHORTSTOPP 3-Way Flat-Bottomed Tee

Appendix E - Thread-O-Ring Fitting

Appendix F - SHORTSTOPP 285 Purge and Equalization Fitting

Compliance Requirements

Reference Documents

Document Rescission

TAPS 2.6 Tapping and Stopping: Supraflow Tee Tapping Procedure

Section 1.0 Purpose

Section 2.0 Scope

Section 3.0 Target Audience

Section 4.0 General

Section 5.0 Tapping Machine

Section 6.0 Tapping Procedure

Operator Qualification (OQ)

Compliance Requirements

Reference Documents

Document Rescission

TAPS 2.7 Tapping and Stopping: TDW PE Branch Saddle-Valve

Section 1.0 Purpose

Section 2.0 Scope

Section 3.0 Target Audience

Section 4.0 General

Section 5.0 Tapping Setup and Drilling Machine

Section 6.0 PE Branch Saddle-Valve

Section 7.0 PE Branch Saddle Fusion

UNCONTROLLED IF PRINTED

- Section 8.0 Preparing for Tap
- Section 9.0 Tapping Operation
- Section 10.0 Completion Operation
- Operator Qualification (OQ)
- Compliance Requirements
- Reference Documents
- Document Rescission

Taps 2.8 Tapping and Stopping: Shim Installation

- Section 1.0 – Purpose
- Section 2.0 – Scope
- Section 3.0 – Target Audience
- Section 4.0 – General Information
- Section 5.0 – Shims
- Section 6.0 – Shim Placement
- Section 7.0 – Shim Welding
- Section 8.0 – Weld the Fitting
- Section 9.0 – Welding Shim to Pipe
- Section 10.0 – Testing
- Operator Qualification (OQ)
- Compliance Requirements
- Reference Documents
- Document Rescission

TAPS 3 Tapping and Stopping: Forms and Reference Materials

- Forms
- References
- Document Rescission

End of Table of Contents

Document Rescission

TAPS 0 Tapping and Stopping – Table of Contents, October 1, 2020

Revision Notes

Location of Changes	Summary of Changes
----------------------------	---------------------------

TAPS 2.8 – Shim Installation	New section – Provides the instructions for the installation of shims on odd size on odd sizes of steel pipe to allow installation of standard size line stopper fittings.
------------------------------	--

TAPPING AND STOPPING

October 1, 2021

TAPS 1 Requirements

1.0 Purpose

This document to provide necessary information to ensure personnel perform tapping and stopping procedures on steel lines in a safe, efficient manner, and in accordance with 49 CFR §192.627.

2.0 Scope

This document addresses the following:

[3.0 Target Audience](#)[4.0 General](#)[5.0 Equipment](#)[6.0 Planning Requirements](#)[7.0 Pre-Job Conference](#)[8.0 Identification of Pipe Before Tapping](#)[9.0 Gauge, Blow-down, and By-pass Fittings](#)[10.0 Testing](#)[11.0 Completion of Tapping / Stopping Operation](#)

Appendices

[Appendix A - Tapping Request Form](#)[Appendix B - Drilling and Stopping Machines - Typical. Images](#)[Appendix C - Testing Consideration - Tapping / Stopping Operation](#)**3.0 Target Audience**

- Gas Engineering
- Gas Tech Engineering (GTE)
- Gas Integrity Management Personnel
- Gas Supervisors
- Gas Field Personnel
- Gas Field Personnel - Welders
- Gas Tech Services (GTS) Supervisors
- Gas Tech Services (GTS) Technicians
- Gas Construction Services Supervisors
- Contract Gas Construction Company Supervisors
- Contract Construction Inspectors
- Contract Welding Inspectors
- Gas Control

4.0 General

- 4.1 Gas field personnel and contractor personnel must be qualified to perform tapping and stopping operations on a pressurized (live) pipeline.
- 4.2 A Tapping Request Form (see [Appendix A](#)) is required for each hot tapping and/or stopping operation to be performed by contractor, Gas Tech Service (GTS) personnel,

UNCONTROLLED IF PRINTED

or AIC personnel from another Operating Area. It applies to all sizes of steel transmission and high-pressure distribution pipelines, or 2-inch and larger distribution pipelines. The Tapping Request Form can also be found in [TAPS 3](#).

- 4.3 A Qualified Individual shall be present while the stopping equipment is being assembled, installed, tested, and during the stopping operations.
 - 4.3.1 A Qualified Individual should remain with stopping equipment until such time that the monitored pressure variations are found to be satisfactory.

Never leave an open-ended pipeline unattended while stopping equipment is in operation.

- 4.4 Pipe ends shall have an approved weld cap (rated for the pipeline pressure) installed at the end of each day's work so that the stopping equipment can be:
 - 4.4.1 Raised,
 - 4.4.2 Tapping valve closed, AND
 - 4.4.3 Equipment left unattended overnight.
- 4.5 When a valve is being used to isolate the pipeline, the open ends shall be capped as outlined above.
- 4.6 All welding shall be by an in-service welding qualified welder using an approved welding procedure. For in-service welding, see [WELD 2.4](#).
- 4.7 When larger than 12 inch diameter hydraulic stopping equipment is utilized it can be left in operation unattended overnight when:
 - 4.7.1 The pipe has not been cut, OR
 - 4.7.2 The pipe has been capped utilizing approved welding procedures, see [WELD 2.4](#).

5.0 Equipment

- 5.1 Ensure that the tapping and stopping equipment is in good operating condition prior to beginning tapping and stopping operations. See [Appendix B](#) for images of drilling and stopping machines.
 - 5.1.1 Conduct a dry run before beginning a tapping and/or stopping operation.
 - 5.1.2 Any malfunctioning equipment should be tagged out-of-service and properly repaired before being used again.
- 5.2 Mueller and T.D. Williamson (TDW) fittings and equipment are used for all taps and stops for steel pipe sizes from $\frac{3}{4}$ inch through 12 inch. See [TAPS 2.4](#) for Mueller and [TAPS 2.5](#) for T.D. Williamson.
- 5.3 TDW and TEAM fittings and equipment are used for taps and stops *larger than 12 inches*. Ameren Illinois (AIC) gas operations personnel may assist in the installation and tapping / stopping of these fittings under the direction of TDW and TEAM qualified personnel.
- 5.4 Refer to the appropriate manufacturer's operating instructions for details regarding use of tapping and stopping equipment.

- 5.5 The Gas Supervisor or GTS Supervisor shall have access to the operating instructions for the tapping / stopping equipment and make such available for gas field personnel to reference and review prior to performing a tap.
- 5.6 See Table 1 for maximum working pressure and tapping sizes for the available drilling machines.

Table 1: Available Drilling Machines

Drilling Machine	Maximum Working Pressure(psig)	Tap Sizes (Inches)
Mueller E-4	500	1/8 - 1-1/2
Mueller E-5	500	1/8 - 1-1/2
Mueller EH-1	1,200	1/8" - 1-1/2
Mueller D-4	500	1/8 - 2-3/8
Mueller D-5	500	1/8 - 3-3/4
Mueller DH-5	1,200	1/8 - 3-3/4
Mueller C1-36	500	2 -12
T.D. Williamson T-18	1,440	1-5/16 -- 4
T. D. Williamson T-101	1,440	up to 6
T. D. Williamson T-101XL	1,440	up to 6
T. D. Williamson 660	1,440	3 -- 12
T. D. Williamson PS2000 (Plastic Only)	150	4, 6, 8

- 5.7 See Table 2 for maximum working pressure and stopping sizes for the available stopping units.

Table 2: Available Stopping Machines

Stopping Machine	Maximum Working Pressure (psig)	Tap Sizes (Inches)
Mueller Unit No. 1	125	1 - 2-1/2
Mueller Unit No. 2	100	3 -- 4
Mueller Unit No. 3	60	6 -- 8
Mueller Unit No. 3SW	275	4, 6, 8
Mueller Unit No. 3SW-500	500	4, 6, 8
Mueller Unit No. 4SW	500	10 -- 12
T.D. Williamson SHORTSTOPP	60	2 -- 12
T. D. Williamson SHORTSTOPP II	150	2 -- 6
T. D. Williamson SHORTSTOPP 275	275	1-1/2 -- 12

6.0 Planning Requirements

- 6.1 Projects that involve hot taps, bypasses, or stop-offs shall be planned to minimize customer service interruptions.
- 6.2 Brief all personnel who are involved in the project and have a clear understanding of their role during normal and abnormal operations.

- 6.3 GTE, GTS Supervisor, Region Gas Engineer, or Gas Supervisor should contact Gas Control to verify if the affected pipeline is remotely monitored.
 - 6.3.1 If monitoring capability is available for the affected system:
 - 1. Include Gas Control in the planning and scheduling process.
 - 2. Request that Gas Control closely monitor the affected pipeline during the planned project to ensure that no unplanned situation occurs.
- 6.4 When planning for stopping operations, GTE, GTS Supervisor, Region Gas Engineer, or Gas Supervisor shall identify the source of gas supply for all connected main segments.
- 6.5 If using a bypass, or if there are two or more feeds into the area, then install a pressure gauge on the live side of each stopper fitting. Monitor the gauge pressure throughout the stopping operation.
 - 6.5.1 For potential over-pressurization or service interruption, see [PRES 2.1](#).
- 6.6 Equipment Pressure Rating
 - 6.6.1 Ensure the stopper fitting is rated for Design MAOP of the pipeline.
 - 1. However, the tapping, stopping machine, and stoppers shall be rated for the actual operating pressure of the main at the time of Region tapping / stopping operation.
 - 6.6.2 If the tapping, stopping machine, and stoppers have a lower rating than the pipeline MAOP, it will be necessary to lower the actual operating pressure of the pipeline to be within operating limits of the equipment.
- 6.7 Gas Engineer or GTE Engineer will provide the purging plan that is to be included in the job packet. For purging methods, see [PURG 2](#).

7.0 Pre-Job Conference

- 7.1 Conduct a pre-job conference to review special considerations, pertinent information, and job assignments associated with tapping and stopping.
- 7.2 If Gas Control will be involved in monitoring the system during the tapping / stopping operation, establish the line of communication between on-site Gas Supervisor and Gas Control.
- 7.3 Verify the pre-job information for all taps each day prior to performing tapping / stopping operations.
- 7.4 Information to be reviewed may include items such as:
 - 7.4.1 For details on specific content of tool kits, refer to Mueller, T.D. Williamson, or TEAM operating instruction manuals.
 - 7.4.2 [PRES 2.1](#) for potential over pressurization or service interruption.
 - 7.4.3 MAOP of the facility to be tapped and the fitting to be used.
 - 7.4.4 Current operating pressure/limitations.
 - 7.4.5 Blow-down considerations.
 - 7.4.6 Re-pressurization and purge plan.
 - 7.4.7 Tool/equipment requirements.
 - 7.4.8 Responsibilities of involved personnel to include operator qualifications and span of control.

- 7.4.9 Direction and number of feeds.
- 7.4.10 Location and accessibility of isolation valve that will or could be used and method of tagging valve as out of service.
- 7.4.11 Method of communication between qualified field personnel monitoring pressures and tapping / stopping operations.

8.0 Identification of Pipe Before Tapping

- 8.1 Confirm operating pressure to ensure the appropriate tapping and stopping equipment is being used before proceeding with tapping.
- 8.2 Gas field personnel should review applicable maps and records and contact operators of other underground facilities to determine location of other lines which may be in vicinity of the pipeline for tapping.
- 8.3 Verify the line Design MAOP to ensure that the tap fitting is rated for the Design MAOP and not just the operating pressure.
- 8.4 Review the following on the exposed pipe to confirm that the pipe is the one to be tapped:
 - 8.4.1 Outside diameter.
 - 8.4.2 Wall thickness.
 - 8.4.3 Coating.
 - 8.4.4 Pipe material.
 - 8.4.5 Joint connection.
 - 8.4.6 Manufacturer's markings.
- 8.5 If necessary, to ensure the exposed pipe is the proper one, gas field personnel should consider extending the excavation or installing a small tap on the pipe to verify content and/or pressure.
- 8.6 Fitting Placement
 - 8.6.1 Locate the tap on a straight section of pipe.
 - 8.6.2 Do not tap through any girth welds.
 - 8.6.3 If the tap is going through a known longitudinal seam, see [WELD 2.4, Paragraph 6.3.5](#) for inspection requirements.
 - 8.6.4 The pipe to be tapped should be free of any significant external or known internal corrosion.
 - 8.6.5 Checking for pipe wall lamination in transmission lines and 4-inch and larger high-pressure steel distribution mains with MAOP of 100 psig or greater is covered in [WELD 2.4, Paragraph 8.2.1](#).
 - 8.6.6 Do not use tapping or drilling machines in tunnels, manholes, or other places that cannot be vented.
 - 8.6.7 To prevent damage to the stopper, place the line stopper fittings so that the minimum distances listed in Table 3 can be maintained between the fitting and any cutting and welding operations.

Table 3: Minimum Distance to Line Stopper

Line Size (Inches)	Minimum Distance (Inches)	Line Size (Inches)	Minimum Distance (Inches)
--------------------	---------------------------	--------------------	---------------------------

UNCONTROLLED IF PRINTED

	Mueller	T.D. Williamson		Mueller	T.D. Williamson
3/4	6	12		10	22
1	6	13		12	24
1-1/4	6	13		16	N/A
2	8	14		18	N/A
3	10	15		20	N/A
4	12	16		24	N/A
6	14	18		30	N/A
8	16	20			

8.7 Where not possible to maintain the recommended minimum distance between stopper face and cutting or welding operation, place auxiliary cooling means, such as wet burlap or wet rags, around the fitting to reduce the temperature.

9.0 Gauge, Blow-down, and By-pass Fittings

9.1 Fittings installed to facilitate tapping / stopping operations may potentially be reused in the future. When installing them, consider the following:

- 9.1.1 Purpose of installed control fitting.
- 9.1.2 Possible need to use control fitting to isolate main segment in an emergency.
- 9.1.3 Location of mainline valves that could be used to isolate main segment.
- 9.1.4 Accessibility of control fitting.
- 9.1.5 Potential need for relocating main segment.

9.2 Pipeline tapping and stopping operations may require installation of fittings to be used for a gauge tap, blow-down, and/or by-pass.

9.2.1 Valve tees, save-a-valve nipples, weld punch tees or other approved fittings shall be used on transmission and high-pressured distribution pipeline. When selecting a fitting, consider the following:

- 1. Pipe material.
- 2. Pipe wall thickness.
- 3. Blow-down time.
- 4. By-pass capacity.
- 5. Flow volume, cooling effect.
- 6. Pipeline Design MAOP.
- 7. Gas Tech Engineering specification.

9.2.2 After completing the tapping / stopping operation, cap the tee outlet with a threaded steel cap/plug or a weld cap/plug.

9.2.3 Leak test the cap/plug under normal operating pressure with leak detection fluid or a leak detection instrument.

9.2.4 Leave the valve tee in the closed position.

9.2.5 Leave the punch tee positioned as follows:

- 1. Up position on pipelines with MAOP greater than 60 psig.

2. Down position on pipelines with MAOP 60 psig or less.

Since these fittings are considered re-useable, they are exempt from the procedures contained in [ABND 2.1, Section 6.0](#), Services.

10.0 Testing

- 10.1 Test the fittings and associated piping prior to tapping in accordance with [PTST 1, Section 10.0](#).

Because of exposure hazards associated with a possible test failure, take precautions to remove personnel a safe distance from the immediate test site.

- 10.2 If the required test pressure for a bottom-out fitting stopper assembly might exceed the collapse pressure of the carrier pipe, see the procedures outlined in [Appendix C](#).

11.0 Completion of Tapping / Stopping Operation

- 11.1 Refer to the manufacturer's operating instructions for specific details directed to using the tapping machine, stopper unit, and completion operation.
- 11.2 When machines or fittings are removed from live mains or lines, install the completion cap as soon as possible.
- 11.3 Upon completion of tapping / stopping operation, verify with Gas Control (if applicable) that their monitoring parameters have returned to normal operation.

End of Instructions.

Operator Qualification (OQ) Required?

YES

- 0641: Visually Inspect Pipe and Components Prior to Installation
- 0801: Welding
- 0811: Visual Inspection of Welding and Welds
- 1651: Purge - Flammable or Inert Gas
- 1081: Tapping a Pipeline (Tap Diameter 2 Inch or Less)
- 1091: Tapping a Pipeline (Tap Diameter Greater Than 2 Inch)
- 1101: Tapping a Pipeline with a Built-In Cutter)
- 1111: Tapping Cast and Ductile Iron Pipe, and Low Pressure Steel Pipe
- 1131: Stopper (Stopp) Pipe
- 1371 Operate Gas Pipeline – System Control Center Operations

Appendices

UNCONTROLLED IF PRINTED

[Appendix A - Tapping Request Form](#)

[Appendix B - Drilling and Stopping Machines - Typical, Images](#)

[Appendix C - Testing Consideration - Tapping / Stopping Operation](#)

Attachments

NONE.

Compliance Requirements

49 CFR Part 192, specifically, §§ 192.151 and 192.627, plus Subparts E and J.

Reference Documents

[PRES 2.3 Pressure Monitoring: ERX Alarm Change Request](#)

[PTST 1 Pressure Testing: Requirements](#)

[PURG 2 Purging: Methods](#)

[TAPS 3 Tapping and Stopping: Forms and Reference Material](#)

[WELD 2.4 Welding: In-Service Welding](#)

Document Rescission

TAPS 1 Tapping and Stopping: Requirements, October 1, 2020.

Revision Notes

Location of Changes	Summary of Changes
Target Audience	Added Gas Control
Operator Qualifications	Added – 1371 – System Control Center Operations

Appendix A - Tapping Request Form

[\(View/download PDF version\)](#)



TAPPING-STOPPING REQUEST
Form 5742 NS

Date of request: ___/___/___ mo/day/yr
Date of tap/stop: ___/___/___ mo/day/yr Time needed: ___ AM ___ PM
To (tapping supervisor): _____
From (originator): _____

Mueller Fitting No. _____ Size _____" Thin Wall Standard
 TDW Fitting No. _____ Size _____"

ANSI Rating of Fitting 150 300 400 600

Tap Only _____
 Tap and Stop _____
 Tap, Stop, and By-pass _____
 Guillotine Saw Request Size _____" Estimated No. of cuts _____

Special Considerations: _____

Anticipated operating pressure in pipe (at time of tap) _____ psig
Anticipated operating pressure in pipe (at time of stop) _____ psig
MAOP of pipeline to be tapped &/or stopped _____ psig
Wall thickness of pipe to be tapped: _____" Tap size requested _____"
Service Area _____ Contact _____ Phone _____
Accounting: RA _____ Project _____ Project Function W/O _____
Work Request # _____

Exact Location of Work to be Performed _____

Brief Description of Work: _____

Boom Safety Distances - Cover Overhead Power Lines:

Appendix B - Drilling and Stopping Machines - Typical, Images



T.D. Williamson T-101



T.D. Williamson T-660

Tapping Machines



PS2000XL
Tapping Machine



SHORTSTOPP®
Plugging/Completion Machine
Pugging: 1-1/2" through 4"
Completion: 1-1/2" through 12"



Muller Model E-5
Drilling Machine



Mueller Model H-17040
Stopping Machine

Appendix C - Testing Consideration - Tapping / Stopping Operation

If the required test pressure for a bottom-out fitting stopper assembly *might exceed* the collapse pressure of the carrier pipe, follow the procedures outlined below.

Step 1: All pipe and fittings shall be pretested to meet the pressure system's design MAOP before welding to the line stopper. Testing may be done with one large assembly or several smaller assemblies based upon engineering designs. Consideration should be given to minimize the number of tie in welds wherever possible.



Step 2: Cut the tested pipe assembly to make fit-up with the line stopper more manageable.

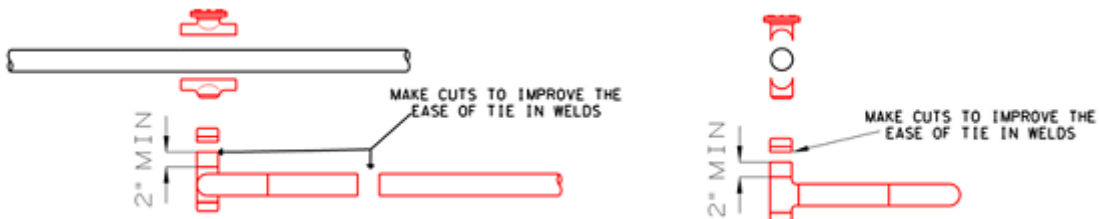

Step 3: Fit up the bottom of the line stopper to the tested tee assembly and then weld to pipeline.

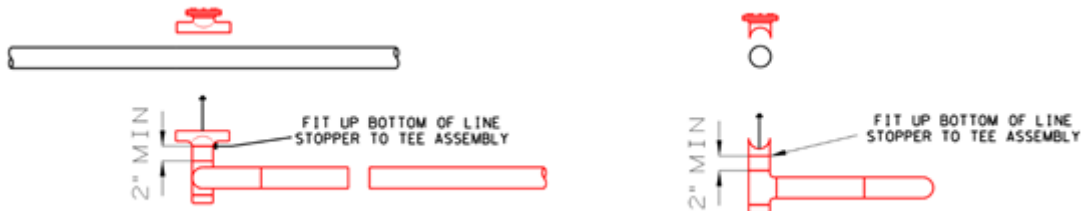

Step 4: Leak test the final assembly prior to tapping at a minimum of 100 psig and a maximum not to exceed operating pressure. Leak test the tie in welds after tapping.

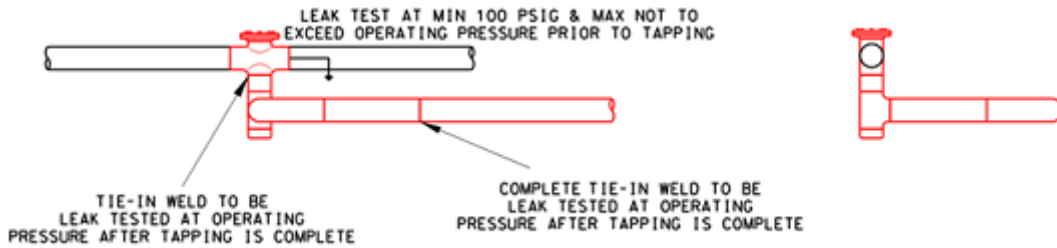

End of Appendix

TAPPING AND STOPPING

October 1, 2020

TAPS 2.1 Dresser Meter Valve Changer

1.0 Purpose

This document covers the Dresser Standard Pipe Stop Changer that permits changing meter valves while the service line is under pressure with no blowing gas. This enhances public and worker safety when needing to replace a leaking meter valve.

2.0 Scope

This document addresses the following:

[3.0 Target Audience](#)[4.0 General](#)[5.0 Standard Pipe Stop Changer](#)[6.0 Meter Riser Stop Changer \(5/8" O.D. Tubing\)](#)

Appendices

[Appendix A - Dresser Stop Changer Image](#)**3.0 Target Audience**

- Gas Engineering
- Gas Supervisors
- Gas Field Personnel
- Gas Construction Services Supervisors

4.0 General

4.1 Most meter valves, 2 inches and less, may be removed and replaced if:

- 4.1.1 The port opening is of sufficient size to allow passage of the plugging unit through the valve, AND
- 4.1.2 Valve outlet has iron pipe threads.

4.2 The maximum pressure to which the valve changers can be used is 60 psig.

5.0 Standard Pipe Stop Changer

5.1 This valve changer incorporates a clamping mechanism in the handle assembly for locking handle grip on the tube to prevent changer body from rotating when turning the handle. Attach the handle before installing in the valve.

5.1.1 See [Appendix A](#) for image of Dresser Stop Changer.

5.1.2 See [TAPS 3](#) for Dresser manual.

5.2 Attach handle.

5.2.1 The handle grip, which is two pieces threaded together, must be loose so the handle will slip over the body tube until the operating nut bottoms in the handle socket.

5.2.2 Screw the grip pieces tightly together to squeeze the rubber rings and clamp the grip on the body tube.

UNCONTROLLED IF PRINTED

- 5.3 Ensure that 1) changer is tightened in the valve, 2) vent valve is closed, and 3) meter valve is open. Carefully insert the plug mechanism through the valve ports and completely into the upstream pipe.
- 5.4 Tighten Plug
 - 5.4.1 Expand plug by holding handle grip and rotate the crank clockwise.
 - 5.4.2 Tighten plug until a noticeable increase in torque exists. Also, observe the shaft collar through hole in the handle arm.
 - 5.4.3 When the collar is about 3/4 inch from top of hole, slide the vent valve down slowly and partially uncover the vent hole to check for audible leakage. Continue tightening, if necessary, until audible leakage stops.
 - 5.4.4 Uncover vent hole completely and hold a finger over vent hole momentarily to check for slow leakage.
 - 1. If noticeable popping occurs in covering and uncovering the hole, tighten the plug another turn (or more) until audible popping stops.
 - 2. Avoid over tightening, as this shortens plug life.
- 5.5 When the plug is tightened securely, the handle can be removed, and changer housing removed from the valve. Carefully slide the housing off the body tube so the valve can be removed for replacement.

Do not depend on this device to stop an open pipe way unassisted, since many variables can affect the retention capabilities of a stop changer in a pipe way. Either use a restraining device or restrain the changer body by hand during the valve removal and changing operation.

- 5.6 Removal
 - 5.6.1 The vent valve must be closed. Release the plug by rotating the handle until the shaft is fully returned (i.e., operating nut engages stop collar).
 - 5.6.2 Carefully withdraw the plug assembly through the valve by oscillating or rotating the body slightly to avoid hang-up and damage to valve ports or changer.

The plug mechanism cannot be withdrawn unless the moveable plug anti-extrusion parts are fully retracted by complete return of the shaft.

6.0 Meter Riser Stop Changer (5/8" O.D. Tubing)

- 6.1 This changer does not require a handle. Use only the thumb and index finger to tighten the plug. The device seals in the riser insert.
- 6.2 Installation
 - 6.2.1 With the changer mounted in the valve and valve open, line pressure will lift the shaft and expand plug. Therefore, shaft must be depressed to insert the plug completely so that the body spool piece stops against the riser.

UNCONTROLLED IF PRINTED

6.2.2 Tighten operating nut until leakage stops and plug is firm.

Do not depend on this device to stop the riser unassisted. Restrain by hand or a fixture during the valve changing operation.

6.3 Removal

6.3.1 Close vent valve.

6.3.2 Back off operating nut against stop collar.

6.3.3 Depress shaft fully to release plug and withdraw changer from valve.

6.4 Storage - Wipe the changer with a clean rag after each usage.

End of Instructions.

Operator Qualification (OQ) Required?

YES

0301: Manually Opening and Closing Valve

1191: Maintenance of Service Valves Upstream of Customer Meter

Appendices

[Appendix A - Dresser Stop Changer Image](#)

Attachments

NONE.

Compliance Requirements

NONE.

Reference Documents

[TAPS 3 Tapping and Stopping: Forms and Reference Materials](#)

Document Rescission

TAPS 2.03 Tapping and Stopping: Dresser Meter Valve Changer, January 1, 2011.

Revision Notes

Location of Changes	Summary of Changes
Not applicable.	This is a new document.

Appendix A - Dresser Stop Changer Image

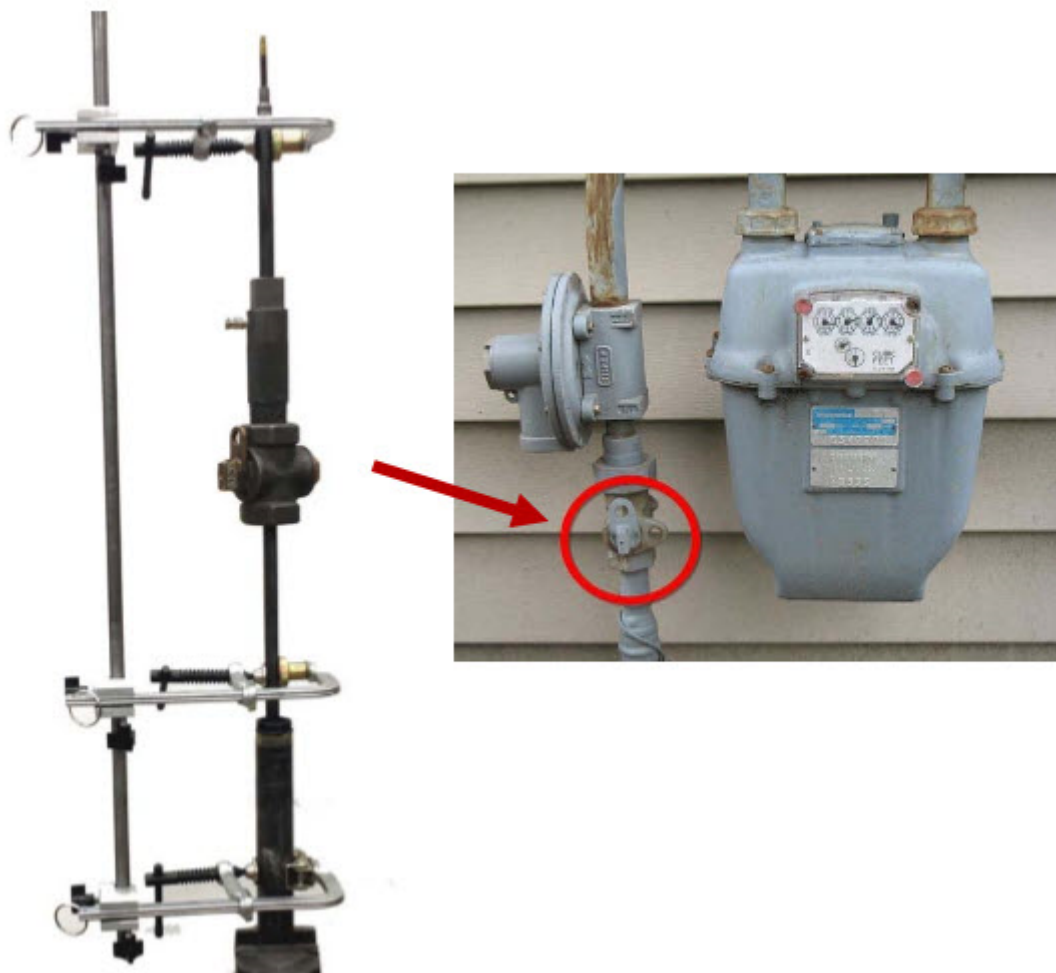

Figure 1: Dresser Standard Pipe Stop Changer

UNCONTROLLED IF PRINTED

TAPPING AND STOPPING

October 1, 2020

TAPS 2.2 Mueller NO-BLO Valve Changer

1.0 Purpose

This document addresses the Mueller NO-BLO Valve Changer, which permits changing meter valves while the service line is under pressure with no blowing of gas. This enhances public and worker safety when needing to replace a leaking meter valve.

2.0 Scope

This document addresses the following:

[3.0 Target Audience](#)[4.0 General](#)[5.0 Equipment Models and Application](#)[6.0 Preparing the Plugging Unit](#)[7.0 Assemble Plugging Unit to Meter Valve](#)[8.0 Attach Safety Clamp to Pipe](#)[9.0 Insert and Expand Rubber Plug](#)[10.0 Remove Old Valve](#)[11.0 Rethread the Pipe](#)[12.0 Install New Meter Valve](#)[13.0 Relax Rubber Plug and Remove Equipment](#)[14.0 Replacing Rubber Plug](#)

Appendices

[Appendix A - Mueller NO-BLO Valve Changers](#)[Appendix B - Mueller Valve Changer Images by Model](#)[Appendix C - Mueller Plugging Units](#)[Appendix D - Mueller Plugging Equipment Images](#)**3.0 Target Audience**

- Gas Engineering
- Gas Supervisors
- Gas Field Personnel

4.0 General

- 4.1 Most meter valves, 2 inches and less, may be removed and replaced if the port opening is of sufficient size to allow passage of the plugging unit through the valve AND if the valve outlet has iron pipe threads.
- 4.2 The maximum pressure to which the valve changers can be used is 60 psig.

5.0 Equipment Models and Application

UNCONTROLLED IF PRINTED

- 5.1 Valve Changers for Mueller 3/4", 1", or 1-1/4" valves - See [Appendix A](#).
- 5.2 Images of Mueller NO-BLO Valve Changer models - See [Appendix B](#).
- 5.3 Plugging Unit sizes - See [Appendix C](#).
- 5.4 Images of Mueller Plugging Equipment - See [Appendix D](#).

6.0 Preparing the Plugging Unit



- 6.1 Before using Stop Changer, remove burrs from inside of pipe by using reamers and special machine adapter nipples under pressure with the F-1 Machine.
- 6.2 Select proper plugging unit according to size of stop to be removed.
- 6.3 Close the stop to be removed.
- 6.4 Purge gas out of piping.
- 6.5 Remove enough pipe and fittings from outlet end of stop to permit easy access.
- 6.6 Examine Valve Changer for proper function. Verify rubber plug is in good condition.
- 6.7 Free-up rubber plug by partially compressing and relaxing it several times. This is done by holding the shaft tube in one hand and turning shaft crank with the other hand alternately clockwise and counterclockwise. See [Figure 1](#).
- 6.8 Lubricate the rubber plug by applying Mueller Rubber Stopper Lubricant (Part # 580657). Also, lubricate the following:
 - 6.8.1 Bleeder O-rings by applying to the outside machined surface of stuffing box and sliding the bleeder ring forward / backward while turning it slightly.
 - 6.8.2 Shaft tube by sliding the stuffing box up and down.
- 6.9 Measure the width of the port opening to ensure that it is equal to or greater than the minimum width for the appropriate rubber plugging unit listed in [Appendix C](#).

7.0 Assemble Plugging Unit to Meter Valve



- 7.1 Fully retract rubber plug into the stuffing box.
- 7.2 Thread stuffing box into outlet of the valve to be removed.
- 7.3 Close the bleeder valve by sliding bleeder ring upward, while turning it.
- 7.4 Open valve fully while carefully lining up valve key with the piping.
- 7.5 Turn the shaft tube until small arrow on tapered portion of shaft tube is lined up with valve key. This arrow locates the flat rubber plug for proper alignment to pass through port opening of the valve.

It is not necessary to locate arrow when using the H-17016 for PE risers.

8.0 Attach Safety Clamp to Pipe



- 8.1 Position safety clamp on the pipe so that locating pin is just touching inlet end of valve to be removed.
- 8.2 Tighten pipe clamp firmly using hand force only. Never use an extension on the vise handle.
- 8.3 Adjust bottom shaft tube clamp to align with keyway of valve to be replaced.
- 8.4 Move top shaft tube clamp approximately 3 inches down from top nut on the safety clamp and fasten loosely. This will help to place the rubber plug into riser.

It may be necessary to take manual measurements for proper placement.

- 8.5 *For 1-1/2" and 2" safety clamps only:* Adjust each knurled shaft clamp positioning sleeve so that shaft tube clamp is approximately in the center of threaded portion of each sleeve.

9.0 Insert and Expand Rubber Plug



- 9.1 Place shaft crank on hexagon shaft nut at top of plugging unit.
- 9.2 Push shaft tube downward through the stuffing box until its tapered portion (with the arrow) is just through the top shaft tube clamp. This will move rubber plug downward through the valve and into inlet pipe below valve.
- 9.3 Hold plugging unit in this position and tighten top shaft tube clamp vise firmly using hand force only. Never use an extension on vise handle. This vise should seat on smaller diameter portion of the shaft tube, with front edge of vise just above the tapered portion of the shaft tube. See Figure 5.



- 9.4 Remove shaft crank. Count and note number of exposed threads on shaft end. This number will be used later when the plug is relaxed. Replace shaft crank.
- 9.5 Expand the rubber plug by turning the shaft crank clockwise until end of the threaded shaft is flush with end of the shaft crank sleeve. A shutoff should be achieved at this point.

UNCONTROLLED IF PRINTED

- 9.6 Open bleeder valve by sliding bleeder ring downward and turning it slightly. Shut-off tightness be indicated by absence of continued gas flow.

The H-17016 for PE risers will not require more than a few turns to create a stop-off. Do not over expand.

- 9.7 If flow continues from the bleeder valve, a shutoff has not been achieved.
- 9.7.1 Close bleeder valve by sliding the bleeder ring upward while turning it slightly.
- 9.7.2 Rotate shaft crank slowly for one additional full turn clockwise.
- 9.7.3 Test again for tightness using bleeder valve.
- 9.7.4 If shut-off still has not been achieved, continue rotating shaft crank one turn at a time, testing with bleeder valve after each turn.

The limit of travel is when the shaft nut contacts a shoulder on the shaft, occurring when the shaft end is approximately 3/8"-1/2" beyond the shaft crank sleeve. See Figure 6.



10.0 Remove Old Valve

Do not attempt to remove the old stop without the safety clamp.

- 10.1 When a shutoff has been achieved, unthread the old valve from pipe.
- 10.2 Slide both the stuffing box with valve upward along the shaft tube. See Figure 7.

UNCONTROLLED IF PRINTED



10.3 Swing bottom shaft tube clamp into position onto shaft tube of plugging unit and secure so bottom edge of the vise is next to riser.

10.4 Tighten clamp vise firmly using hand force only. Never use an extension on the vise handle.

10.5 Remove shaft crank. See Figure 8.



10.6 Open clamp vise on top shaft tube clamp and swing it out of position.

UNCONTROLLED IF PRINTED

- 10.7 Slide stuffing box (with the valve as a unit) off the shaft tube, turning the assembly slightly as it is moved along the shaft tube. See Figure 9. Be careful not to drag stuffing box O-Rings over exposed threads.



- 10.8 Remove the old valve from stuffing box.

- 10.9 If necessary to rethread the pipe, cut off and rethread pipe end before installing new valve. Refer to Section 11.

11.0 Rethread the Pipe

- 11.1 After removing the old valve from service pipe, examine the riser threads. If threads have been damaged, thread the old meter valve back onto the pipe with stuffing box attached, then relax rubber plug.

- 11.2 Loosen safety clamp and slide it away from bottom end of valve.

- 11.3 Remove short locating pin on safety clamp and replace it with the long locating pin. Slide safety clamp upward toward bottom end of valve until locating pin touches valve. Then, tighten safety clamp securely.

- 11.4 Insert and expand rubber plug. Remove old valve as was done previously.

- 11.5 Measure back 1-3/8" from end of the service pipe.

This is maximum amount that can be cut off without damaging the rubber plug that is expanded in the service pipe.

- 11.6 Remove long locating pin and cut off the old threads. Use a 3-wheel type narrow pipe cutter to cut off threads.

- 11.7 Slide the cut off piece of service pipe and old valve upward so bottom shaft tube clamp can be attached. Once attached, disengage the top shaft tube clamp allowing the old valve and cut off pipe to be removed.
- 11.8 Place die head on the shaft tube and engage top shaft tube clamp. Disengage bottom shaft tube clamp and proceed to rethread service pipe.
- 11.9 After threads are cut, remove die head in the same manner as was done in Subsection 11.7.
- 11.10 Install new stop valve as described in Section 12.

12.0 Install New Meter Valve

- 12.1 Thread the stuffing box into the outlet end of a new Mueller valve.
- 12.2 Open the valve fully, carefully lining up valve key with piping.
- 12.3 Slide the valve with stuffing box over the end of the shaft tube, being careful not to drag stuffing box O-rings over exposed threads. Turn the assembly slightly as it is moved along the shaft tube.
- 12.4 Swing top shaft tube clamp back into position and tighten vise.
- 12.5 Open the vise of bottom shaft tube clamp and swing it out of position See Figure 10.

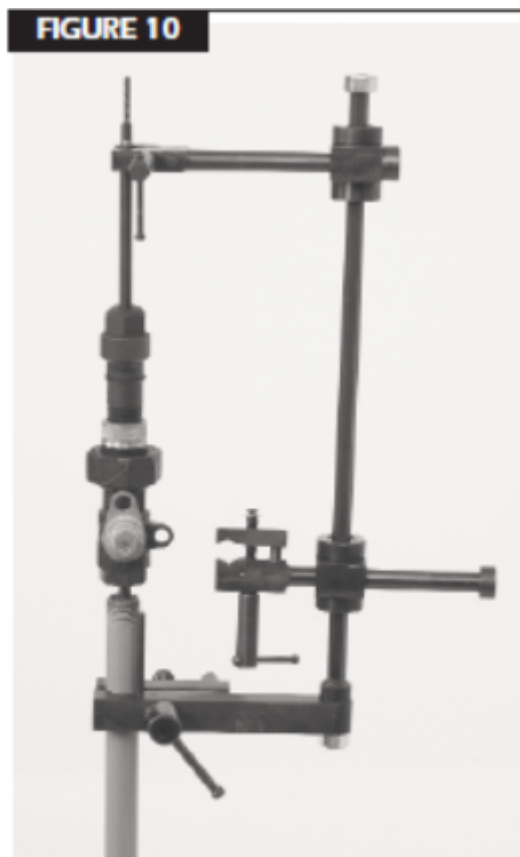

- 12.6 Brush and clean the threads on the end of the pipe and apply non-hardening pipe thread sealant.
- 12.7 Move meter valve with stuffing box downward and thread valve onto the end of the pipe. If possible, make a pressure tight connection, tighten valve until its key is in line with small arrow on shaft tube.

If valve contacts locating pin before making a tight pipe connection, then unthread valve from piping (without removing it from valve changer). Remove the locating pin and reassemble end valve to pipe.

12.8 Close the bleeder valve by sliding the bleeder ring upward while turning it slightly. See Figure 11.



13.0 Relax Rubber Plug and Remove Equipment

13.1 Replace shaft crank on shaft nut.

13.2 Rotate shaft crank counterclockwise until the number of threads noted in [Subsection 9.4](#) above are exposed at the end of threaded shaft.

13.3 Important: Pressure inside pipe may force the shaft tube upward. Hold down on shaft tube by placing the hand solidly against the face of shaft crank. See Figure 12. Use other hand to open vise of top shaft tube clamp and slowly slide the tube upward so rubber plug passes through the valve and fully into the stuffing box.

If necessary, turn the shaft tube so arrow is in line with valve key, which aligns the rubber plug with the port opening through valve. See [Figure 13](#).



13.4 Close valve.

13.5 Open bleeder valve by sliding the bleeder ring downward exhausting the gas from the stuffing box.

13.6 Remove the equipment.

UNCONTROLLED IF PRINTED

13.7 Reconnect the outlet piping, purge, check for leaks, and place in service.

14.0 Replacing Rubber Plug

The rubber plug is subjected to great stress and distortion in normal use. Replace when found worn or damaged.

14.1 Fully relax the rubber plug by turning shaft crank counterclockwise.

14.2 Remove shaft crank and hold the plugging unit in a vertical position with end of shaft resting on a table or similar solid support.

14.3 Grasp rubber plug with one hand and partially compress plug by pulling downward. This will disengage the locking feature between the end ferrule and locknut. See Figure 14.



14.4 Remove locknut, end ferrule, and rubber plug. See Figure 15.



UNCONTROLLED IF PRINTED

- 14.5 Clean shaft and lubricate with Mueller Rubber Stopper Lubricant (Part # 580657).
- 14.6 Slide on a new rubber plug and reinstall end ferrule.
- 14.7 Compress rubber plug approximately 1/16"-1/8" by pulling downward on the end ferrule.
- 14.8 Replace locknut and align its sides with slot in the end ferrule.
- 14.9 Relax rubber plug which will force the end ferrule into contact with the locknut and prevent it from backing off.

End of Instructions.

Operator Qualification (OQ) Required?

YES

0301: Manually Opening and Closing Valve

0311: Adjust and Monitor Flow or Pressure-Manual Valve Operation

0641: Visually Inspect Pipe and Components Prior to Installation

Appendices

[Appendix A - Mueller NO-BLO Valve Changers](#)

[Appendix B - Mueller Valve Changer Images by Model](#)

[Appendix C - Mueller Plugging Units](#)

[Appendix D - Mueller Plugging Equipment Images](#)

Attachments

NONE.

Compliance Requirements

NONE.

Reference Documents

NONE.

Document Rescission

TAPS 2.02 Tapping and Stopping: Mueller NO-BLOW Valve Changer, January 1, 2016.

Revision Notes

Location of Changes	Summary of Changes
Not applicable.	This is a new document.

Appendix A - Mueller NO-BLO Valve Changers

A-1. Mueller Valve Changers and Applications

Mueller Model	Sizes (Inches)	Schedule or Size Pipe	Comments
Valve Changer:			
H-17010	3/4, 1 or 1-1/4	Sch. 40 steel pipe	w/ Safety Clamp and 3/4", 1" & 1-1/4" Plugging Unit

UNCONTROLLED IF PRINTED

H-17013	3/4, 1 or 1-1/4	Sch. 80 steel pipe	w/ Safety Clamp and 3/4", 1" & 1-1/4" Plugging Unit
H-17012	1-1/2 or 2	Sch. 40 steel pipe	w/ Safety Clamp and 1-1/2" & 2" Plugging Unit
H-17014	1-1/2 or 2	Sch. 80 steel pipe	w/ Safety Clamp and 1-1/2" & 2" Plugging Unit
Plugging Unit:			
H-17016	1/2 x 3/4 1/2 x 1	1/2" CTS PE riser	Purchase Safety Clamp separately; 2nd # in size = valve size (i.e., 3/4" & 1")
H-17017	1/2 x 3/4	1/2" Sch. 40 steel pipe	Purchase Safety Clamp separately; 2nd # in size = valve size (i.e., 3/4")

Appendix B - Mueller Valve Changer Images by Model

Note: All Models have maximum working pressure at 60 psig.

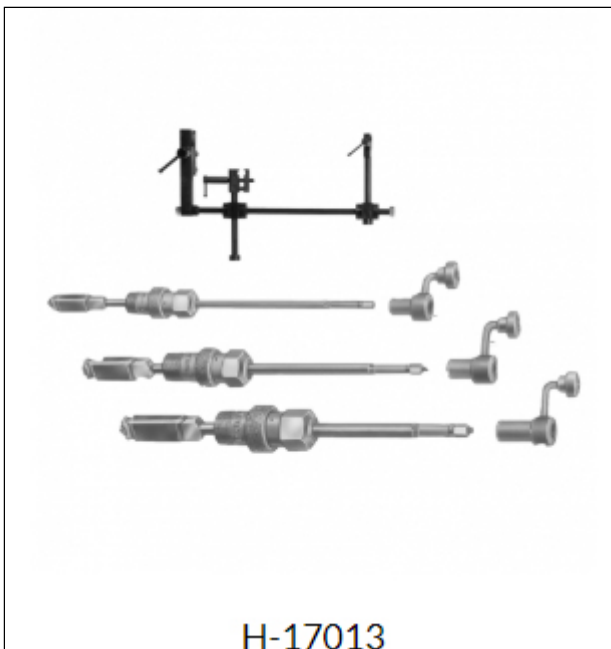

UNCONTROLLED IF PRINTED

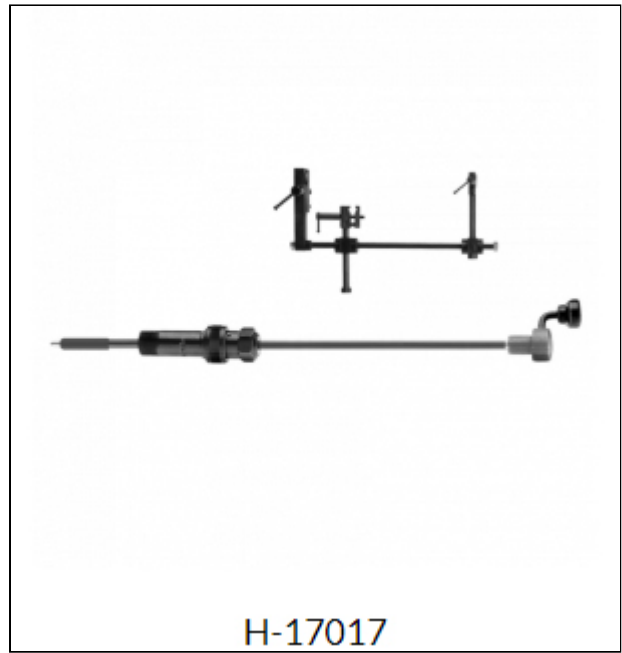

Appendix C - Mueller Plugging Units

Plugging Unit Size (Inches)	Valve Size (Inches)	Minimum Port	
		Width (Inches)	Height (Inches)
1/2 x 3/4	3/4	13/32	23/32
1/2 x 1	1	17/32	31/32
3/4	3/4	13/32	23/32
1	1	17/32	31/32
1-1/4	1-1/4	11/16	1-9/32
1-1/2	1-1/2	25/32	1-19/32
2	2	1-5/32	2

Appendix D - Mueller Plugging Equipment Images

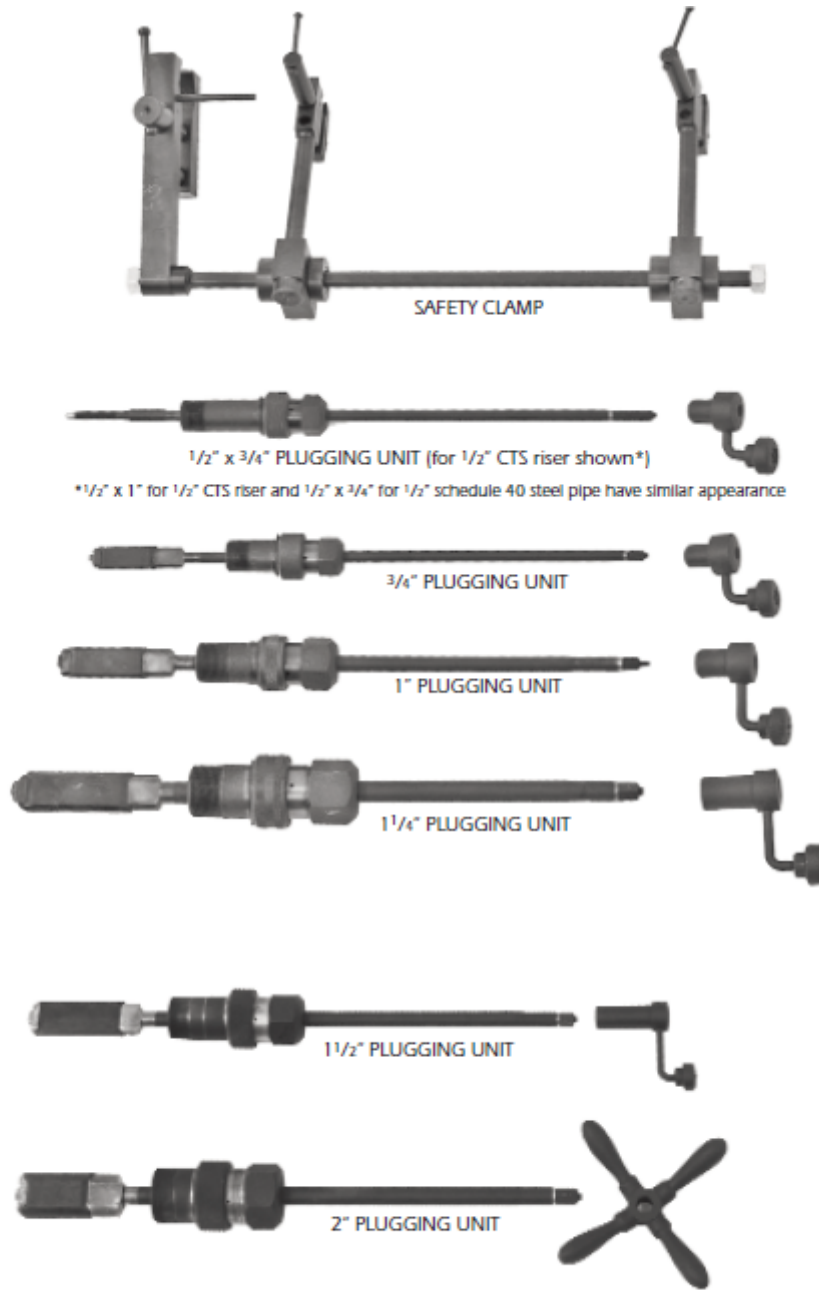

UNCONTROLLED IF PRINTED

TAPPING AND STOPPING

December 15, 2021

TAPS 2.3 Mueller AUTOPERF Tee

1.0 Purpose

This document details the installation instructions for the Mueller AUTOPERF tee.

2.0 Scope

This document addresses the following:

[3.0 Target Audience](#)[4.0 General](#)[5.0 Views of Tee](#)[6.0 Maximum Pipe Wall Thickness for AUTOPERF Tee](#)[7.0 Installation Instructions](#)**3.0 Target Audience**

- Gas Engineering
- Gas Tech Engineering (GTE)
- Gas Integrity Management Personnel
- Gas Supervisors
- Gas Field Personnel
- Gas Field Personnel - Welders
- Gas Tech Services (GTS) Supervisors
- Gas Tech Services (GTS) Technicians
- Gas Construction Services Supervisors
- Contract Gas Construction Company Supervisors
- Contract Construction Inspectors
- Contract Welding Inspectors

4.0 General

- 4.1 The tee utilizes a self-contained perforator for tapping the main.
- 4.2 The perforator retains the pipe coupon and functions as a shut-off.
- 4.3 These installation instructions should be followed to ensure a successful tap.
- 4.4 Maximum pipe wall thickness for perforator use with various sizes of AUTOPERF tees is shown in [Table 1](#).
- 4.5 If the pipe wall thickness is not known or cannot be verified through testing or experience to be less than 0.281, a Mueller valve tee, H-17656, or Mueller curb valve tee, H-17800, should be used in place of the AUTOPERF tee.
- 4.6 Refer to the manufacturer's operating instructions for details regarding use of tapping and stopping equipment. See [TAPS 3](#).

5.0 Views of Tee



Figure 1: AUTOPERF Tee and AUTOPERF Transition Tee

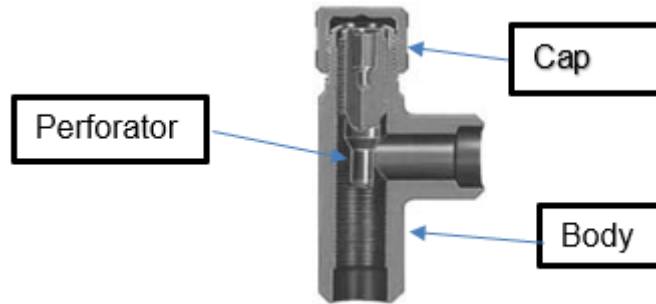

Figure 2: Cut Away View

6.0 Maximum Pipe Wall Thickness for AUTOPERF Tee

Table 1: Mueller AUTOPERF Tee Data

Model & Size Tip (Inch)	Size (Inch)	Maximum Wall Thickness (Inch)	Stock Code
Mueller H-18101- 5/16" perforator tip	3/4	0.281	19 23 192
Mueller H-18102 - 3/8" perforator tip	1/2 x 1/2	0.250	19 33 265
	3/4 x 3/4	0.281	19 33 268
	3/4 x 1	0.281	19 12 429
Mueller H-18104 - Transition Tee	3/4 x 1" CTS HDPE w/3/8 tip	0.281	19 12 597

Notes:

1. With exception of the 1/2" x 1/2" H-18102, maximum wall thickness is 0.281 inch.
2. [STLP 2.2, Appendix A](#). Steel Pipe Stock Code Table lists the wall thickness for the stock coded pipe.

7.0 Installation Instructions

- 7.1 Remove the completion cap and perforator from the tee body.
- 7.2 Weld the service tee to the main in accordance with Ameren Illinois (AIC) welding procedures.

Do not position over or within 1 inch either side of a girth weld.

UNCONTROLLED IF PRINTED

- 7.2.1 Ensure tee is square to the main.
- 7.2.2 There should be no gap between the service tee and top of main.
- 7.2.3 Allow weld to cool to ambient temperature. Do not quench with water or soap.
- 7.3 After tee has cooled, attach the service line to the tee.
- 7.4 Pressure test the tee and service line in accordance with [PTST 1](#).
- 7.5 Insert perforator into the tee body until top of the perforator is 1/4 inch below the top of the tee opening.

Do not apply lubricant to the perforator or the tee body.

- 7.6 Crimp the top of tee with the appropriate crimping tool (Mueller H-18092 or H-18097).
- 7.7 Using the Mueller H-18090 NO-BLOW operating wrench (or similar ratchet drive wrench), rotate the perforator and pierce the main by rotating the ratchet handle clockwise in 1/4-turn increments. Once the perforator contacts the main, continue turning in this manner until perforation is complete.

Do not stop the operation or attempt to back out the perforator before piercing the pipe.

In the event of a failed perforation, do not attempt to use a second perforator in the same tee body.

- 7.8 Once the main is pierced, continue turning the perforator clockwise until the perforator seats lightly in the main.
- 7.9 Back out the perforator by turning the ratchet handle counterclockwise until the perforator firmly contacts the crimped top of the tee, forming a metal to metal seal.
- 7.10 Using thread sealant, install the completion cap and tighten firmly.

End of Instructions.

Operator Qualification (OQ) Required?

YES

0641: Visually Inspect Pipe and Components Prior to Installation

0801:Welding

0811:Visual Inspection of Welding and Welds

1081:Tapping a Pipeline (Tap Diameter 2 Inch or Less)

1101:Tapping a Pipeline with a Built-In Cutter)

Appendices

UNCONTROLLED IF PRINTED

NONE.

Attachments

NONE.

Compliance Requirements

49 CFR Part 192, specifically, §§ 192.151 and 192.627, plus Subparts E and J.

Reference Documents

[PTST 1 Pressure Testing: Requirements](#)

[STLP 2.2 Steel Pipe: Design Pressure](#)

[TAPS 3 Tapping and Stopping: Forms and Reference Materials](#)

[WELD 1 Welding: Requirements](#)

Document Rescission

TAPS 2.5 Tapping and Stopping: Mueller AUTOPERF Tee, October 1, 2021.

Revision Notes

Location of Changes	Summary of Changes
Section 6.0 – Maximum Pipe Wall Thickness for AUTOPERF Tee	Stock Code Corrections: Mueller H-18101, 3/4" . 5/16" Perforator – 19 23 192 Mueller H-18102, 3/4" x 1", 3/8" Perforator – 19 12 429

TAPPING AND STOPPING

October 1, 2022

TAPS 2.4 Mueller Tapping and Stopping Procedure

1.0 Purpose

The following is a general procedure for Mueller tapping and stopping operations. Also included are appendices showing Mueller fittings that are approved components for use on gas pipelines by Ameren Illinois (AIC).

2.0 Scope

This document addresses the following:

[3.0 Target Audience](#)

[4.0 General](#)

[5.0 Tapping Operation](#)

[6.0 Stopping Operation](#)

[7.0 Completion Operation](#)

Appendices

[Appendix A - Mueller Stopper Fittings](#)

[A-1 Low-Pressure Line Stopper Fitting](#)

[A-2 Service Line Stopper Fitting](#)

[A-3 Line Stopper Fittings](#)

[A-4 Mueller Bottom-Out Line Stopper Fittings](#)

[Appendix B - Mueller Tees](#)

[B-1 Service Tees](#)

[B-2 Service Stop Tees](#)

[B-3 Curb Stop Tees](#)

[Appendix C - Mueller "Save-A-Valve" Drilling Nipple](#)

[Appendix D - Mueller Pig Plug / Line Stopper Fitting Insert](#)

3.0 Target Audience

- Gas Engineering
- Gas Tech Engineering (GTE)
- Gas Supervisors
- Gas Field Personnel
- Gas Field Personnel - Welders
- Gas Tech Services (GTS) Supervisors
- Gas Tech Services (GTS) Technicians
- Gas Construction Services Supervisors
- Contract Gas Construction Company Supervisors
- Contract Construction Inspectors
- Contract Welding Inspectors

4.0 General

4.1 For general requirements and considerations, see [TAPS 1](#).

UNCONTROLLED IF PRINTED

- 4.2 Mueller fittings and equipment are used for all taps and stops for steel pipe sizes from 3/4 inch through 12 inch. See [Appendix A thru Appendix D](#).
- 4.3 Ensure that the pressure rating of the selected component is adequate for the pipeline application.
- 4.4 For available Mueller Drilling Machines with listed maximum working pressure, see [TAPS 1, Table 1](#).
- 4.5 For general information and particulars for the Mueller AUTOPERF Tee, see [TAPS 2.3](#).
- 4.6 Refer to the manufacturer's operating instructions for details regarding use of tapping and stopping equipment. See [TAPS 3](#).
- 4.7 Ensure a fire extinguisher is present at the location where the work is being performed.
- 4.8 Shims are stock coded
 - 4.8.1 19 83 124, for use with 2" Mueller two-piece line-stopper fittings, for use on 1-1/4" IPS steel pipe.
 - 4.8.2 19 83 126, for use with 8" Mueller two-piece line-stopper fittings, for use on 7" IPS steel pipe.

5.0 Tapping Operation

- 5.1 Clean facilities in accordance with applicable joining procedures. See [WELD 1, Section 8.0](#), Preparation for Welding.
- 5.2 Attach and inspect the fitting in accordance with applicable procedures for in-service welding. See
 - 5.2.1 [WELD 2.4, Subsection 6.3](#), Hot Tap Fittings.
 - 5.2.2 [WELD 2.4, Section 8.0](#), Welding Procedures.
 - 5.2.3 [WELD 4](#) for In-Service WPSs.
 - 5.2.4 [WELD 2.4, Subsection 8.6](#), Inspection Requirements.
- 5.3 Leak test the fitting prior to tapping in accordance with applicable testing procedures. See [PTST 1, Section 13.0](#), Pressure Testing: Components.
- 5.4 Install valve that is appropriately rated for the operating pressure.
- 5.5 Perform line-up procedures for all flanged line stopper fittings.
- 5.6 Attach drilling machine with valve in open position with boring bar fully retracted.

Support tapping equipment when performing horizontal taps.

- 5.7 Close valve to ensure bit does not interfere with valve operation.
- 5.8 Open valve with bit in fully retracted position.
- 5.9 Extend bit until it contacts pipe.
- 5.10 Identify travel extent and mark the tapping assembly.

Travel specifications can be referenced in Mueller operating instructions (blue books).

- 5.11 Perform tapping operation.
- 5.12 Retract the boring bar and close valve.
- 5.13 Relieve pressure above valve.
- 5.14 Remove tapping equipment.
- 5.15 Retrieve the tapping coupon.
- 5.16 Tag the tapping coupon for material sampling.
 - 5.16.1 A tag is provided in the job packet.
 - 5.16.2 The tagged coupon shall be delivered to Integrity Management at completion of the project.

6.0 Stopping Operation

- 6.1 Apply Mueller rubber stopper lube to stoppers. Do not lubricate rounded bottoms.
- 6.2 Attach stopping machine to valve. Keep bar fully retracted.
- 6.3 Where possible with valve, equalize pressure.

Bar is still under pressure. DO NOT lean over bar.

- 6.4 Open valve completely.
- 6.5 Mark maximum stopper travel.

Travel specifications can be referenced in Mueller operating instructions (blue books).

- 6.6 Monitor gauges to ensure system pressure.
- 6.7 Compress the stopper to stop off the line. Do not over compress rubber. See Mueller operating instructions for travels required to effectively stop off.
- 6.8 Table 1 lists the recommended minimum distance from the stopper to cutting and welding operations.

Table 1: Minimum Distance from Stopper to Cutting and Welding Operations

Size (Inches)	Minimum Distance (Inches)	Size (Inches)	Minimum Distance (Inches)
3/4	6	4	12
1	6	6	14
1-1/4	6	8	16
2	8	10	18

UNCONTROLLED IF PRINTED

3	10	12	20
---	----	----	----

6.8.1 If it is not possible to maintain the recommended minimum distance, use additional means of cooling (e.g., wrap wet burlap or wet rags around the fitting) to reduce the temperature.

6.9 Relax stopper slowly and retract it. If stopper does not retract, equalize pressure on both sides of rubber stopper using natural gas or inert gas only.

6.10 Close valve.

6.11 Relieve pressure above valve and remove stop machine.

7.0 Completion Operation

7.1 Attach completion machine to valve. Keep bar fully retracted.

7.2 Where possible with valve, equalize pressure.

Bar is still under pressure. DO NOT lean over bar.

7.3 Open valve completely.

7.4 Carefully lower completion plug into stopper fitting.

7.5 Tighten completion plug into fitting by rotating clockwise.

7.6 Relieve pressure above valve and remove completion machine.

7.7 Install cap and leak test joints with leak detection solution.

End of Instructions.

Operator Qualification (OQ) Required?

YES

0641: Visually Inspect Pipe and Components Prior to Installation

0801: Welding

0811: Visual Inspection of Welding and Welds

1081: Tapping a Pipeline (Tap Diameter 2 Inch or Less)

1091: Tapping a Pipeline (Tap Diameter Greater Than 2 Inch)

1101: Tapping a Pipeline with a Built-In Cutter)

1111: Tapping Cast and Ductile Iron Pipe, and Low Pressure Steel Pipe

1131: Stopper (Stopp) Pipe

Appendices

[Appendix A - Mueller Stopper Fittings](#)

[A-1 Low-Pressure Line Stopper Fitting](#)

[A-2 Service Line Stopper Fitting](#)

[A-3 Line Stopper Fittings](#)

UNCONTROLLED IF PRINTED

[A-4 Mueller Bottom-Out Line Stopper Fittings](#)

[Appendix B - Mueller Tees](#)

[B-1 Service Tees](#)

[B-2 Service Stop Tees](#)

[B-3 Curb Stop Tees](#)

[Appendix C - Mueller "Save-A-Valve" Drilling Nipple](#)

[Appendix D - Mueller Pig Plug / Line Stopper Fitting Insert](#)

Attachments

NONE.

Compliance Requirements

49 CFR §§ 192.151 and 192.627

49 CFR Part 192 Subparts E and J

Reference Documents

[PTST 1 Pressure Testing: Requirements](#)

[TAPS 1 Tapping and Stopping: Requirements](#)

[TAPS 2.3 Tapping and Stopping: Mueller AUTOPERF Tee](#)

[TAPS 3 Tapping and Stopping: Forms and Material References](#)

[WELD 1 Welding: Requirements](#)

[WELD 2.4 Welding: In-Service Welding](#)

[WELD 4 Welding: Forms and Reference Materials](#)

Document Rescission

TAPS 2.4 Tapping and Stopping – Mueller Tapping and Stopping Procedure, October 1, 2021

Revision Notes

Location of Changes	Summary of Changes
Subsection 4.8	New – Shims are stock code: 19 83 124, for use with 2" Mueller two-piece line stopper fittings, for use on 1-1/4" IPS steel pipe. 19 83 126, for use with 8" Mueller two-piece line-stopper fittings, for us on 7" IPS steel pipe.
Appendix B-3 – Curb Valve Tee	Added – Pictures of H-17800 and H-17900 with 2" square head.

Appendix A - Mueller Stopper Fittings

A-1. Low-Pressure Line Stopper Fitting



For Use on Schedule 40 Steel Pipe Only				
Size (Inches)	Stock No.	Mueller Part No.	Rating (psig)	Tap Size (Inches)
3/4	19 33 036	H-17190	250	13/16
1	19 33 041	H-17190	250	15/16
1-1/4	19 12 476	H-17190	250	1-1/4
2	19 12 477	H-17190	250	1-3/4
3	19 33 015	H-17190	250	2-3/4
4	19 12 479	H-17190	250	3-3/4

For Use on Thin Wall Steel Pipe Only				
Size (Inches)	Stock No.	Mueller Part No.	Rating (psig)	Tap Size (Inches)
3	19 23 147	H-17192	250	2-3/4
4	19 23 148	H-17192	250	3-3/4

A-2. Service Line Stopper Fitting



Size (Inches)	Stock No.	Mueller Part No.	Rating (psig)	Tap Size (Inches)
3/4	19 33 004	H-17055	250	0.875 (7/8)
3/4	19 33 005	H-17056	1,440	0.875 (7/8)
1-1/4	19 23 149	H-17055	250	1.125 (1-1/8)

A-3. Line Stopper Fittings



Size (Inches)	Stock No.	Mueller Part No.	Rating (psig)	Tap Size (Inches)
---------------	-----------	------------------	---------------	-------------------

UNCONTROLLED IF PRINTED

2 *	19 33 009	H-17125	250	2.250 (2-1/4)
2 *	19 33 291	H-17126	1,440	2.250 (2-1/4)
Shim	19 83 124	n/a	n/a	n/a

*Note: Shim to use a 2" fitting on 1-1/4" pipe.



For Use on Standard Wall Steel Pipe				
Size (Inches)	Stock No.	Mueller Part No.	Rating (psig)	Tap Size (Inches)
3	19 12 277	H-17256	720	3-1/4
4 x 3 *	19 12 279	H-17256	720	4-1/4
4 x 3 *	19 33 296	H-17257	960	4-1/4
4 x 3 *	19 33 720	H-17258	1,440	4-1/4
4	19 12 275	H-17255	275	4-1/4
4	19 12 278	H-17256	720	4-1/4
4	19 33 022	H-17258	1,440	4-1/4
6	19 33 024	H-17256	720	6-1/4
6	19 33 719	H-17258	1,440	6-1/4
8	19 33 028	H-17256	720	8-1/4
8	19 33 300	H-17258	1,440	8-1/4
10	19 33 031	H-17255	275	12-1/2
10	19 33 030	H-17257	960	12-1/2
12	19 33 032	H-17255	275	12-1/2
12	19 33 304	H-17257	960	12-1/2

*Note: Size 4" x 3" fitting modified to fit 3" pipe using 4" tools and equipment.

For Use on Thin Wall Steel Pipe				
Size (Inches)	Stock No.	Mueller Part No.	Rating (psig)	Tap Size (Inches)
6	19 23 153	H-17275	275	6-1/2
6	19 12 601	H-17276	720	6-1/2
6	19 33 297	H-17278	1,440	6-1/2
8	19 33 040	H-17275	275	8-1/2
8	19-12-604	H-17276	720	8-1/2
8	19 33 301	H-17278	1,440	8-1/2

A-4. Mueller Bottom-Out Line Stopper Fittings

UNCONTROLLED IF PRINTED



Size (Inches)	Stock No.	Mueller Part No.	Rating (psig)	Tap Size (Inches)
1-1/4 (1)	19 33 042	H-1708503-420	250	2-1/4
2 (2)	19 33 045	H-1712504-550	250	2-1/4
2 (2)	19 33 046	H-1712604-550	1,440	2-1/4
Shim	19 83 124	n/a	n/a	n/a

Notes:

- (1) Fitting is no longer in Mueller catalog but is still available, See [TAPS 3](#).
- (2) Shim to use a 2" fitting on 1-1/4" pipe.
- (3) Completion plug for 2" H-17125 and H-17126 has O-Ring seal. See Sect. 6.0, Line Stopper Fittings.



For Use on Standard Wall Steel Pipe With Schedule 40 Bottom Opening				
Size (Inches)	Stock No.	Mueller Part No.	Rating (psig)	Tap Size (Inches)
3	19 33 014	H-17260	275	3-1/4
3	19 33 016	H-17261	720	3-1/4
4 x 3 x 4 *	19 33 295	H-17261-99022-799	720	4-1/4
4	19 12 470	H-17260	275	4-1/4
4	19 12 268	H-17261	720	4-1/4
6	19 33 025	H-17261-99000	720	6-1/4
8	19 33 027	H-17260	275	8-1/4
10	19 33 570	H-17260-748	275	12-1/2
10	19 33 303	H-17264	960	12-1/2
12	19 33 571	H-17260-750	275	12-1/2
12	19 33 305	H-17264	960	12-1/2

* Note: 4" x 3" fitting modified to fit 3" pipe using 4" tools and equipment.

For Use on Standard Wall Steel Pipe With Schedule 20 Bottom Opening				
Size (Inches)	Stock No.	Mueller Part No.	Rating (psig)	Tap Size (Inches)
4 x 3 x 3 *	19 12 301	H-17261-99021-799	720	4-1/4

* Note: 4" x 3" fitting modified to fit 3" pipe using 4" tools and equipment.

UNCONTROLLED IF PRINTED

For Use on Thin Wall Steel Pipe With Schedule 40 Bottom Opening				
Size (Inches)	Stock No.	Mueller Part No.	Rating (psig)	Tap Size (Inches)
6	19 33 023	H-17280	275	6-1/2
6	19 33 035	H-17281	720	6-1/2
6	19 33 298	H-17283	1,440	6-1/2
8	19 33 034	H-17280	275	8-1/2
8	19 33 039	H-17281	720	8-1/2

For Use on Thin Wall Steel Pipe With Thin Wall Bottom Opening				
Size (Inches)	Stock No.	Mueller Part No.	Rating (psig)	Tap Size (Inches)
6	19 23 166	H-17286	275	6-1/2
6	19 23 170	H-17287	720	6-1/2
8	19 23 171	H-17287	720	8-1/2

Appendix B - Mueller Tees

B-1. Service Tees

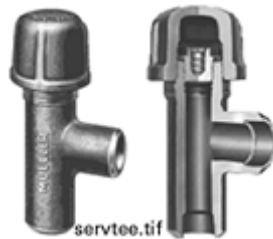

Size (Inches)	Stock No.	Mueller Part No.	Rating (psig)	Tap Size (Inches)
1 x 1	19 33 276	H-17500	250	3/4
1 x 1	19 33 277	H-17501	1,440	3/4
1-1/4 x 1-1/4	19 33 280	H-17500	250	1
1-1/4 x 1-1/4	19 23 201	H-17501	1,440	1
2 x 2	19 33 285	H-17500	250	1-1/2
2 x 2	19 33 286	H-17501	1,440	1-1/2



Size (Inches)	Stock No.	Mueller Part No.	Rating (psig)	Tap Size (Inches)
2 x 2	19 12 231	H-17502	250	1-1/2

B-2. Service Stop Tees

UNCONTROLLED IF PRINTED

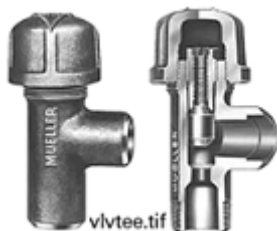

Size (Inches)	Stock No.	Mueller Part No.	Rating (psig)	Tap Size (Inches)
1" x 1"	19 33 548	H-17650	250	5/8"
1 x 1	19 23 203	H-17656	1,440	5/8
1-¼ x 1-¼	19 33 555	H-17650	250	7/8
1-¼ x 1-¼	19 33 556	H-17656	1,440	7/8
1-¼ x 2	19 33 557	H-17650	250	7/8
1-¼ x 2	19 33 559	H-17656	1,440	7/8
2 x 2	19 33 561	H-17650	250	1-1/2
2 x 2	19 33 562	H-17656	1,440	1-1/2

B-3. Curb Stop Tees - A 2 inch square Operating Head is also available and approved for use.

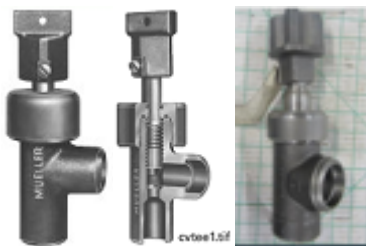

Size (Inches)	Stock No.	Mueller Part No.	Rating (psig)	Tap Size (Inches)
1" x 1"	19 12 229	H-17800	1,440	5/8"
2" x 2"	19 12 230	H-17800	1,440	1-3/8"



Size (Inches)	Stock No.	Mueller Part No.	Rating (psig)	Tap Size (Inches)
1" x 1"	39 22 148	H-17900	1,200	None

Appendix C - Mueller "Save-A-Valve" Drilling Nipple

Note: This is a weld fitting used for purging, by-pass, and equalizing work.



Size (Inches)	Stock No.	Mueller Part No.	Rating (psig)	Tap Size (Inches)
3/4 x 2	19 73 984	H-17490	250	1/2
3/4 x 3	19 73 985	H-17491	1,440	1/2
1 x 3	19 73 986	H-17490	250	5/8
1-1/4 x 3	19 73 987	H-17490	250	3/4
1-1/4 x 3	19 73 988	H-17491	1,440	3/4
2 x 3	19 23 188	H-17491	1,440	1-1/2
3 x 3	19 73 991	H-17491	1,440	2-5/8

Appendix D - Mueller Pig Plug / Line Stopper Fitting Insert



Stock Number	Size (Inches)	Description	Mueller Number
19 83 224	6	Solid, Thin Wall Fitting	682786
19 83 223	6	Solid, Standard Wall Fitting	682785
19 83 226	8	Solid, Thin Wall Fitting	682773
19 83 225	8	Solid, Standard Wall Fitting	682772
19 83 228	10	Solid, Standard Wall Fitting	682774
19 83 227	10	Slotted, Standard Wall Fitting	682643
19 83 230	12	Solid, Standard Wall Fitting	682775
19 83 229	12	Slotted, Standard Wall Fitting	682644

End of Appendices

UNCONTROLLED IF PRINTED

TAPPING AND STOPPING

October 1, 2022

TAPS 2.5 T.D. Williamson Tapping and Stopping Procedure**1.0 Purpose**

This document provides a general procedure for T.D. Williamson (TDW) tapping and stopping operations for application by Ameren Illinois (AIC). Also included are appendices showing TDW fittings that are approved components for use on gas AIC pipelines.

2.0 Scope

This document addresses the following:

[3.0 Target Audience](#)**[4.0 General](#)****[5.0 Tapping Operation](#)****[6.0 Stopping Operation](#)****[7.0 Completion Operation](#)**

Appendices

[Appendix A - SHORTSTOPP Welding Fitting](#)**[Appendix B - SHORTSTOPP 3-Way Tee](#)****[Appendix C - SHORTSTOPP Spherical 3-Way Tee \(Standard and 300D\)](#)****[Appendix D - SHORTSTOPP 3-Way Flat-Bottomed Tee](#)****[Appendix E - Thread-O-Ring Fitting](#)****[Appendix F - SHORTSTOPP 285 Purge and Equalization Fitting](#)****3.0 Target Audience**

- Gas Engineering
- Gas Tech Engineering (GTE)
- Gas Supervisors
- Gas Field Personnel
- Gas Field Personnel - Welders
- Gas Tech Services (GTS) Supervisors
- Gas Tech Services (GTS) Technicians
- Gas Construction Services Supervisors
- Contract Gas Construction Company Supervisors
- Contract Construction Inspectors
- Contract Welding Inspectors

4.0 General

- 4.1 For general requirements and considerations, see **[TAPS 1](#)**.
- 4.2 For the various TDW fittings approved for use by AIC, reference the list under **[Appendices](#)**.
- 4.3 For general information and procedure on use of the TDW PE Branch Saddle Valve, see **[TAPS 2.7](#)**.
- 4.4 Ensure that the pressure rating of the selected component is adequate for the pipeline application.

UNCONTROLLED IF PRINTED

- 4.5 Refer to the manufacturer's operating instructions for details regarding use of tapping and stopping equipment. See [TAPS 3](#).
- 4.6 Ensure fire extinguisher is present at the location where the work is being performed.

5.0 Tapping Operation

- 5.1 Clean facilities in accordance with applicable joining procedures. See [WELD 1, Section 8.0](#), Preparation for Welding.
- 5.2 Attach and inspect the fitting in accordance with applicable procedures for in-service welding. See
 - 5.2.1 [WELD 2.4, Subsection 6.3](#), Hot Tap Fittings.
 - 5.2.2 [WELD 2.4, Section 8.0](#), Welding Procedures.
 - 5.2.3 [WELD 4](#) for In-Service WPSs.
 - 5.2.4 [WELD 2.4, Subsection 8.6](#), Inspection Requirements.
- 5.3 Leak test the fitting prior to tapping in accordance with applicable testing procedures. See [PTST 1, Section 13.0](#), Pressure Testing: Components.
- 5.4 Install valve appropriately rated for operating pressure.
- 5.5 Test valve to ensure it operates properly (leave valve in open position).
- 5.6 Assemble tapping equipment.
- 5.7 Take all required measurements and record on tapping card.
- 5.8 Dry run completion plug.
- 5.9 Install tapping equipment.
- 5.10 Mark "lower-in" distance on the tapping shaft.
- 5.11 Lower cutter to top of piping and back it off 1/4 turn.
- 5.12 Check "lower-in" mark on shaft.
- 5.13 Mark "tapping" distance on shaft.
- 5.14 Start tapping.
- 5.15 When pilot bit pierces the piping, turn off bleeder valve, and lower drill in by hand until shell cutter contacts piping (back it off 1/4 turn).
- 5.16 Resume tapping until "tapping" distance is reached (should be able to lower bit by hand at this point).
- 5.17 Raise tapping head out of piping and pass the valve.
- 5.18 Close valve.
- 5.19 Open bleeder valve.
- 5.20 Remove tapping equipment.
- 5.21 Retrieve the tapping coupon.
- 5.22 Tag the tapping coupon for material sampling.
 - 5.22.1 A tag is provided in the job packet.
 - 5.22.2 The tagged coupon shall be delivered to Integrity Management at completion of the project.

UNCONTROLLED IF PRINTED

6.0 Stopping Operation

6.1 For the recommended minimum distance from the stopper to cutting and welding operations, see Table 1.

Table 1: Minimum Distance from Line Stopper to Cutting/Welding Operation

Size (Inches)	Minimum Distance (Inches)
3/4	12
1	13
1-1/4	13
2	14
3	15
4	16
6	18
8	20
10	22
12	24
16	27
18	29
20	30
24	34
30	38

7.0 Completion Operation

- 7.1 Install tool to insert completion plug.
- 7.2 Open valve (on high pressure taps, the internal bypass must be opened before opening valve).
- 7.3 Install completion plug.
- 7.4 Close valve (also close internal bypass if applicable).
- 7.5 Remove completion plug tool.
- 7.6 Carefully open valve and check that completion plug is properly seated.
- 7.7 Remove valve.
- 7.8 Install cap onto stopper fitting.

End of Instructions.

Operator Qualification (OQ) Required?

YES

0591: Leak Test at Operating Pressure

0641: Visually Inspect Pipe and Components Prior to Installation

0801: Welding

0811: Visual Inspection of Welding and Welds

UNCONTROLLED IF PRINTED

- 1081: Tapping a Pipeline (Tap Diameter 2 Inch or Less)
- 1091: Tapping a Pipeline (Tap Diameter Greater Than 2 Inch)
- 1101: Tapping a Pipeline with a Built-In Cutter)
- 1111: Tapping Cast and Ductile Iron Pipe, and Low Pressure Steel Pipe
- 1131: Stopper (Stopp) Pipe

Appendices

[Appendix A - SHORTSTOPP Welding Fitting](#)

[Appendix B - SHORTSTOPP 3-Way Tee](#)

[Appendix C - SHORTSTOPP Spherical 3-Way Tee \(Standard and 300D\)](#)

[Appendix D - SHORTSTOPP 3-Way Flat-Bottomed Tee](#)

[Appendix E - Thread-O-Ring Fitting](#)

[Appendix F - SHORTSTOPP 285 Purge and Equalization Fitting](#)

Attachments

NONE.

Compliance Requirements

49 CFR §§ 192.151 and 192.627

49 CFR Part 192 Subparts E and J

Reference Documents

[PTST 1 Pressure Testing: Requirements](#)

[TAPS 1 Tapping and Stopping: Requirements](#)

[TAPS 2.7 Tapping and Stopping: TDW PE Branch Saddle Valve](#)

[TAPS 3 Tapping and Stopping: Forms and Reference Material](#)

[WELD 1 Welding: Requirements](#)

[WELD 2.4 Welding: In-Service Welding](#)

[WELD 4 Welding: Forms and Reference Materials](#)

Document Rescission

TAPS 2.5 Tapping and Stopping: T.D. Williamson Tapping and Stopping Procedure, December 15, 2021

Revision Notes

Location of Changes	Summary of Changes
2.0 Scope – Appendices	Appendix D – Inserted – 3-Way in description.
2.0 Scope – Appendices	Added Appendix F – SHORTSTOPP 285 Purge and Equalization Fittings

Appendix F SHORT-STOPP 285	This is a flat bottom 2 inches shortstopp for purging and equalization on steel pipe 6 inches and larger with MAOP of 285 psig or less.
----------------------------	---

Appendix A - SHORTSTOPP Welding Fitting



ANSI Class 150				
Size (Inches)	Stock No.	TDW Part No.	Rating (psig)	Top
1-1/4	19 23 172	06-1179-0000	285	Threaded
1-1/2	19 23 173	26-0211-0000	285	Threaded
2	19 12 144	26-0212-0000	285	Threaded
3	19 23 175	26-0213-0000	285	Threaded
4	19 12 663	06-7213-0000	285	Flanged
6	19 23 534	06-7214-0000	285	Flanged
8	19 23 544	06-7215-0000	285	Flanged
10	19 23 548	06-7216-0000	285	Flanged
12	19 23 558	06-7217-0000	275	Flanged
4 x 6	19 73 216	06-9541-0000	285	Flanged

Note: Pressure ratings based on a Class 3 design rating (Design Factor = 0.50).

Appendix B - SHORTSTOPP 3-Way Tee



ANSI Class 150				
Size (Inches)	Stock No.	TDW Part No.	Rating (psig)	Top
1-1/4	19 23 177	06-6741-0000	285	Threaded
1-1/2	19 23 178	26-0216-0000	285	Threaded
2	19 08 417	26-0217-0000	285	Threaded
3	19 23 613	26-0218-0000	285	Threaded
4	19 12 197	06-7218-0000	285	Flanged
6	19 23 616	06-7219-0000	285	Flanged
8	19 23 619	06-7220-0000	285	Flanged
12	Non-stock	06-7222-0000	220	Flanged

UNCONTROLLED IF PRINTED

4 x 6	19 73 217	06-7239-0406-01	285	Flanged
-------	-----------	-----------------	-----	---------

Note: Pressure ratings based on a Class 3 design rating (Design Factor = 0.50).

Appendix C - SHORTSTOPP Spherical 3-Way Tee (Standard and 300D)



ANSI Class 150				
Size (Inches)	Stock No.	TDW Part No.	Rating (psig)	Top
4	19 23 183	26-0934-0000	285	Flanged
8	19 83 190	06-7225-0000	285	Flanged

Note: Pressure ratings based on a Class 3 design rating (Design Factor = 0.50).

ANSI Class 300				
Size (Inches)	Stock No.	TDW Part No.	Rating (psig)	Top
2"	19 23 652	26-0935-0000	740	Threaded
3"	19 33 739	26-0936-0000	740	Threaded
4"	19 83 186	26-0937-0000	740	Flanged
6"	19 83 182	06-7378-0000	659	Flanged
10"	19 83 188	26-1141-0000	575	Flanged

Note: Pressure ratings based on a Class 3 design rating (Design Factor = 0.50).

Appendix D - SHORTSTOPP 3-Way Flat-Bottomed Tee



ANSI Class 150				
Size (Inches)	Stock No.	TDW Part No.	Rating (psig)	Top
2	19 23 609	26-0220-0000	285	Threaded
3	Non-stock	26-0221-0000	285	Threaded
4	19 73 250	06-7239-0400-01	285	Flanged

Note: Pressure ratings based on a Class 3 design rating (Design Factor = 0.50).

Appendix E - Thread-O-Ring Fitting

Note: This TDW weld fitting is used for 1) purging, 2) by-pass, and 3) equalizing work.



Size (Inches)	Stock No.	TDW Part No.	Rating (psig)
2	19 73 767	TR-0000-0001-00	3,600

Appendix F - SHORTSTOPP 285 Purge and Equalization Fitting

NOTE: This 2 inches TDW ShortStopp 285, Class 150, weld fitting for purging and equalizing applications on steel pipe 6 inches and larger.



Size (Inches)	Stock No.	TDW Part No.	Rating (psig)
2	Non-stock	26-0319-0000 (no bevel)	285

End of Appendices

UNCONTROLLED IF PRINTED

TAPPING AND STOPPING

October 1, 2021

TAPS 2.6 Supraflow Tee Tapping Procedure

1.0 Purpose

This document describes the tapping procedure for installing the Supraflow tees on PE mains.

2.0 Scope

This document addresses the following:

[3.0 Target Audience](#)

[4.0 General](#)

[5.0 Tapping Procedure](#)

3.0 Target Audience

- Gas Engineering
- Gas Tech Engineering (GTE)
- Gas Integrity Management Personnel
- Gas Supervisors
- Gas Field Personnel
- Gas Construction Services Supervisors
- Contract Gas Construction Company Supervisors
- Contract Construction Inspectors

4.0 General

- 4.1 The Supraflow tees are shown as electrofusion fittings in [POLY 2.5, Appendix A](#).
- 4.2 To attach Supraflow tees to a PE main, use electrofusion procedures for saddle fittings. See [POLY 2.5](#).
- 4.3 The Supraflow tee shall be leak tested after fusion is completed and prior to tapping in accordance with [PTST 1, Section 13](#), Components.
- 4.4 Supraflow tees are type PE4710 with a maximum operating pressure rating of 150 psig.
- 4.5 Gas Field Personnel shall be qualified to use the Supraflow PE tapping equipment. See image below.



Groebner Supraflow Tapping Tee Equipment

- 4.6 Contact the Gas Training Center for training and use of the Supraflow PE tapping equipment.

UNCONTROLLED IF PRINTED

4.7 See [TAPS 1](#) for general operational considerations related to any tapping operation.

4.8 Ensure fire extinguisher is present at the location where the work is being performed.

5.0 Tapping Procedure

5.1 Remove PE dirt cap and steel cap with wrench provided in the tapping kit (see [Figure 1](#)).

5.1.1 Remove safety pin.

5.1.2 Place both the steel cap and safety pin inside the PE dirt cap.

5.1.3 Set the PE dirt cap aside. It will be used later at the completion of the tap.



Figure 1

5.2 Select Drill Rod (see [Figure 2](#)).

5.2.1 Check color code on the Supraflow tee.

5.2.2 Select matching color-coded drill rod.

5.2.3 Thread the drill rod onto the drill head, hand tight only. (Do not use wrench to tighten.)

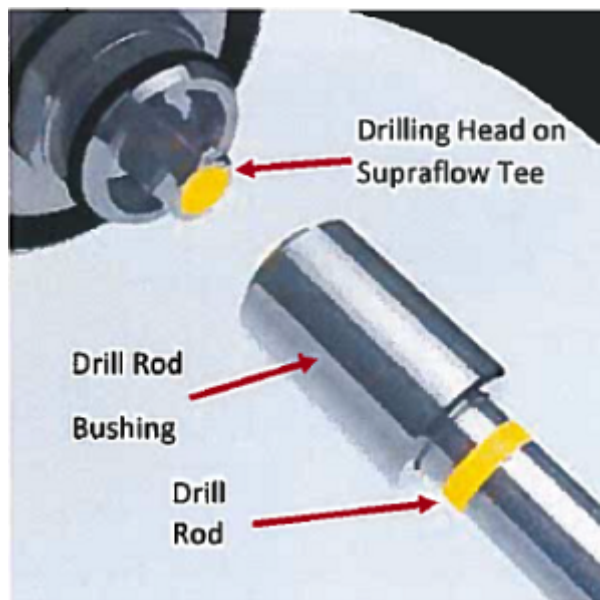

Figure 2

5.3 Insert or Slide Drill Rod onto Drilling Machine (see [Figure 3](#)).

- 5.3.1 First, ensure the stopper plate on the drilling machine is all the way up (see [Figure 4](#)).
- 5.3.2 Insert or slide drill rod onto drilling machine. Silicone spray may be applied to drill rod to ease attachment.
- 5.3.3 Thread drill rod bushing onto drilling head hand tight (approximately 3 to 4 turns) to attach drilling machine to Supraflow tee. Do not use wrench to tighten.
- 5.3.4 Ensure relief valve is closed.
- 5.3.5 Attach pressure gauge.

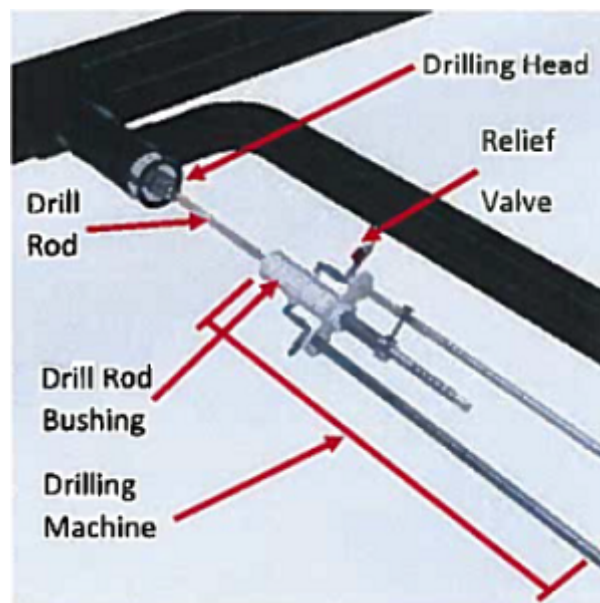

Figure 3

5.4 Break Drill Rod Loose (see [Figure 4](#)).

- 5.4.1 Break drill rod loose from the tee housing by turning clockwise (approximately 6 to 7 complete revolutions) using wrench as provided.



Figure 4

- 5.5 Lower Drill Rod (see [Figure 5](#)).

- 5.5.1 Lower drill rod until achieving contact with gas main.

1. If cutter does not contact the main, place pin into the drill rod hole and run the drilling threads in by hand until achieving contact, OR
2. If cutter touches the main, lift the drill rod back up enough to insert locking pin into the closest hole (depending on the size of tap being made).

- 5.5.2 Mark the smooth arm with tape across from the knurled sleeve. Use this mark as reference on where to stop when retracting drill rod.

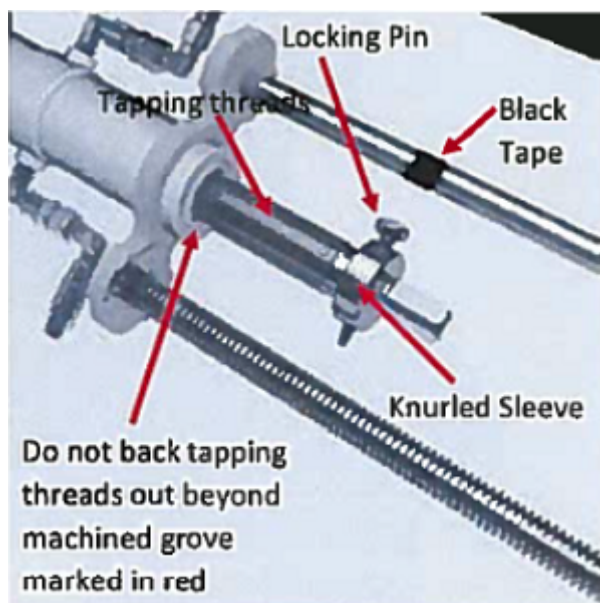

Figure 5

- 5.6 Tapping the Main (see [Figure 6](#)).

5.6.1 Using the ratchet:

1. Start ratcheting the drill rod downward (clockwise) through the gas main until knurled sleeve touches the drilling machine collar.
2. Drill rod will stop at this point as a positive stop.

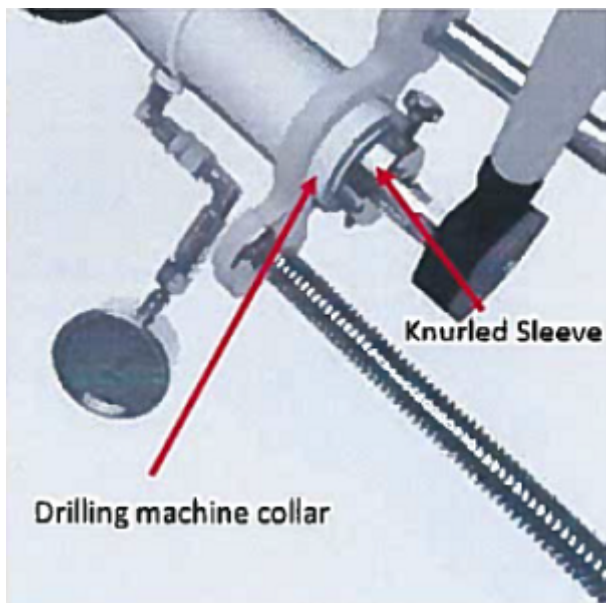

Figure 6

5.7 Extracting Drill Rod (see [Figure 7](#)).

- 5.7.1 Using the ratchet, start ratcheting drill rod upward (counterclockwise) until knurled sleeve is back where it started (reference the tape mark).

Do not extend the tapping threads beyond the red machined groove marked in the tapping threads.

- 5.7.2 Begin screwing the stopper plate downward until it stops over top of the drill rod.
- 5.7.3 Pull the locking pin (located in the collar on the drill rod) to release the drill rod. Pin will remain in collar.

The stopper plate is used to safely control the drill rod action due to it now being under full line pressure.

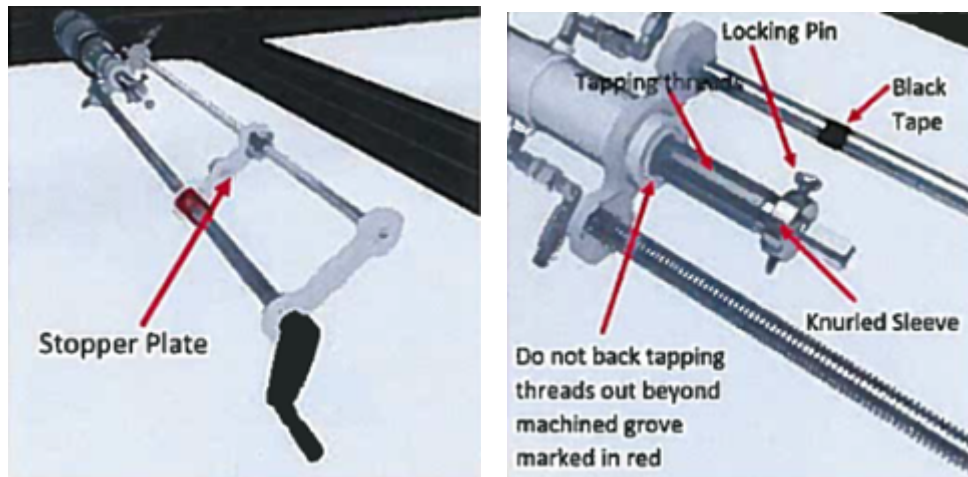

Figure 7

- 5.7.4 Begin screwing the stopper plate upward to its upmost position (see [Figure 8](#)).
- 5.7.5 Drill rod should push up against the stopper plate as it rises. If it does not, pull the drill rod up by hand as the stopper plate moves upward.
- 5.7.6 Once the drill rod is fully extracted, thread the drill rod counterclockwise the rest of the way with wrench to set the cutter (approximately 6 to 7 complete revolutions).
- 5.7.7 Snug with wrench.

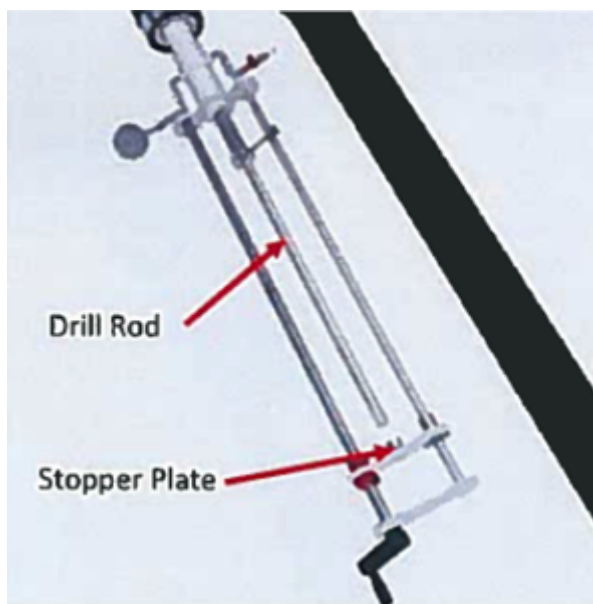

Figure 8

- 5.8 Removing Drilling Machine (see [Figure 9](#)).
- 5.8.1 Open relief valve and ensure a complete seal. If seal is not complete, unseat and reseal the cutter.
- 5.8.2 Remove the pressure gauge.
- 5.8.3 Unthread drilling machine until loose.
- 5.8.4 Slide back drill machine off the drilling rod.
- 5.8.5 Unthread drill rod bushing.

5.8.6 Remove the drilling rod.

5.8.7 Soap test for leaks.

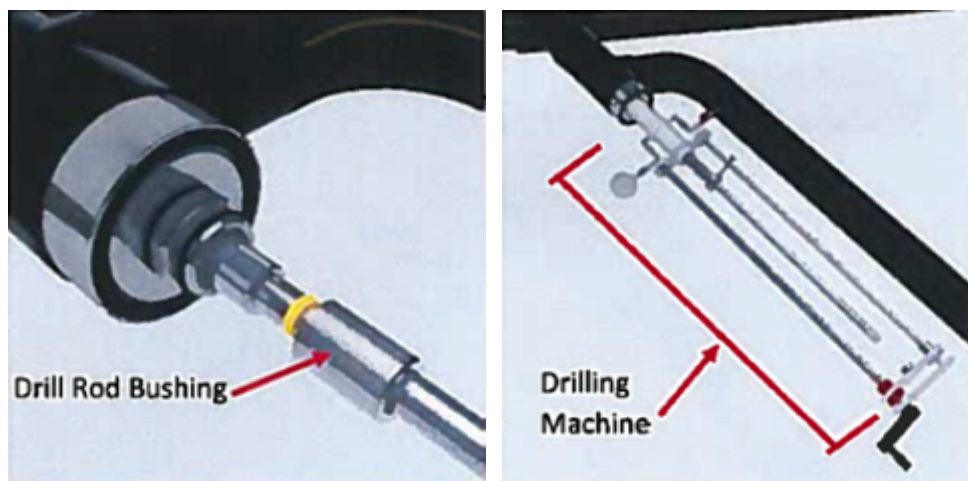

Figure 9

5.9 Replace Caps on Supraflow Tee (see [Figure 10](#)).

5.9.1 Replace safety pin into cutter.

5.9.2 Thread on steel cap; hand tighten and then snug with wrench.

5.9.3 Soap test for leaks.

5.9.4 Attach PE cap with bolt.

5.9.5 Snug bolt with wrench.

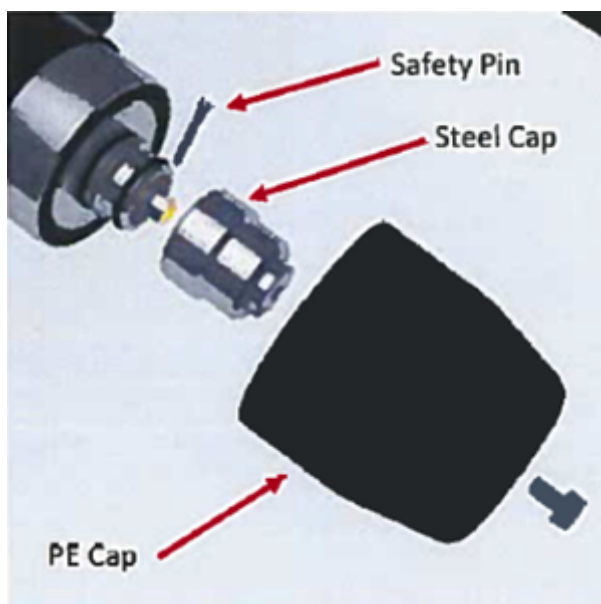

Figure 10

End of Instructions.

Operator Qualification (OQ) Required?

YES

UNCONTROLLED IF PRINTED

0561: Pressure Test - Nonliquid Medium-MAOP Less than 100 Psi

0591: Leak Test at Operating Pressure

0641: Visually Inspect Pipe and Components Prior to Installation

1091: Tapping a Pipeline (Tap Diameter Greater Than 2 Inch

1101: Tapping a Pipeline with a Built-In Cutter)

Appendices

NONE.

Attachments

NONE.

Compliance Requirements

49 CFR §§ 192.151 and 192.627

49 CFR Part 192 Subparts F and J

Reference Documents

[POLY 2.5 Polyethylene Pipe: Electrofusion](#)

[PTST 1 Pressure Testing: Requirements](#)

[TAPS 1 Tapping and Stopping: Requirements](#)

Document Rescission

TAPS 2.6 Tapping and Stopping: Supraflow Tee Tapping Procedure, October 1, 2020

Revision Notes

Location of Changes	Summary of Changes
Subsection 4.4	Correction – maximum operating pressure is 150 psig.
Subsection 4.8	New – Ensure fire extinguisher is present at the location where work is being performed.

TAPPING AND STOPPING

October 1, 2022

TAPS 2.7 TDW PE Branch Saddle-Valve

1.0 Purpose

This document details the material, equipment, and instructions for installing the T.D. Williamson (TDW) polyethylene (PE) branch saddle-valve fitting on polyethylene (PE) pipe.

2.0 Scope

This document addresses the following:

[3.0 Target Audience](#)[4.0 General](#)[5.0 Tapping Setup and Drilling Machine](#)[6.0 PE Branch Saddle-Valve](#)[7.0 PE Branch Saddle Fusion](#)[8.0 Preparing for Tap](#)[9.0 Tapping Operation](#)[10.0 Completion Operation](#)**3.0 Target Audience**

- Gas Engineering
- Gas Tech Engineering (GTE)
- Gas Supervisors
- Gas Field Personnel
- Gas Construction Services Supervisors
- Contract Gas Construction Company Supervisors
- Contract Construction Inspectors

4.0 General

- 4.1 Gas Field Personnel shall be qualified to use the T.D. Williamson (TDW) PE tapping equipment.
- 4.2 Contact the Gas Training Center for training and use of the TDW PE tapping equipment.
- 4.3 See [TAPS 1](#) for general operational considerations related to any tapping operation.
- 4.4 Refer to the manufacturer's operating instructions for details regarding use of tapping and stopping equipment. See [TAPS 3](#).
- 4.5 TDW PE Branch Saddle-Valve can only be installed on PE systems with Design MAOP of 100 psig or less due to the manufacturer's pressure rating.
- 4.6 Ensure fire extinguisher is present at the location where the work is being performed.

5.0 Tapping Setup and Drilling Machine

- 5.0 Tapping Setup and Drilling Machine
- 5.1 [Figure 1](#) shows the full set-up. Further detail on the tapping/drilling machine is shown in [Figure 2](#).

UNCONTROLLED IF PRINTED

5.2 The TDW PE tapping machine # PS2000XL shall be used for tapping the TDW PE branch saddle-valve.

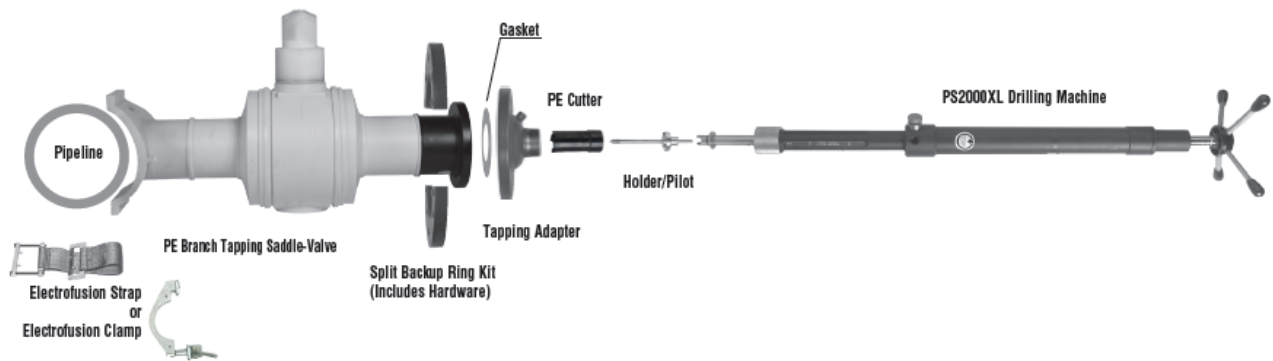

Figure 1: Tapping Setup View



Figure 2: TDW Tapping Machine

6.0 PE Branch Saddle-Valve

6.1 Branch saddle fittings are available for high density (PE3408) pipe through the MDF (Material Distribution Facility) Storeroom. See Table 1.

Table 1: TDW Branch Saddle Fittings -- Availability

Main Size (inches)	Branch Size (inches)	Stock Code	TDW Part Number	Pressure Rating (psig)
4	4	19 67 283	P6-0404-2363-23	100
6	4	19 67 282	P6-0406-2363-23	100
8	4	19 67 281	P6-0408-2363-23	100

7.0 PE Branch Saddle Fusion

- 7.1 For general reference regarding electrofusion on PE pipe, see [POLY 2.5, Section 10.0](#), Joint Assembly, and [Section 11.0](#), Fusion.
- 7.2 Clean the existing pipe where the PE branch saddle valve fitting will be fused. See [POLY 2.5, Subsection 8.1](#), Couplings, Caps, Elbows and Saddle Fittings.
- 7.3 Using the saddle as a guide, mark the existing pipe a minimum of 1/2 inch past each end of the saddle.
- 7.4 Using an approved rotary peeler, ensure that all oxidation is removed from the PE pipe at the proposed fitting location. If oxidation is not fully removed, then repeat peeling. For the allowable number of passes, see [POLY 2.5, Subsection 9.5](#), Peeling.

- 7.5 Clean the pipe and saddle fusing surface using alcohol or alcohol wipes (minimum 96% alcohol solution). Be careful not to touch or allow any contaminants to touch the fusion area of either surface.
- 7.6 Using the appropriate clamping device, clamp the PE branch saddle valve onto the scraped area.
- 7.7 Support the fitting with a fixed source (e.g., wood, ground) to ensure that the weight of fitting is not pulling against the fusion.
- 7.8 Turn on electrofusion processor and attach leads to the PE branch saddle fitting.
- 7.9 Scan the barcode on the fitting.

Some electrofusion processors may have an auto detection feature that allows the processor to determine fitting information, for some fittings, without scanning the barcode.

- 7.10 Verify the fusion time shown on the processor display by comparing it with the fusion time listed on the barcode label of the branch saddle.

DO NOT START THE FUSION if the time on the label and the processor time are not the same.

- 7.10.1 If the processor time does not match the time listed on the barcode label, it may be necessary to manually set the fusion time.

1. Refer to the electrofusion processor manual for instructions on manually setting the fusion time.

- 7.11 Once the fusion is complete, remove the leads and allow the fusion to cool the prescribed amount of time before continuing.

8.0 Preparing for Tap

- 8.1 Assemble all necessary equipment.
 - 8.1.1 Refer to the necessary tapping machine manual for instructions.
 - 8.1.2 Ensure use of the proper tapping adapter and proper cutter, which are specific to tapping PE pipe.
- 8.2 Ensure that cutter is completely retracted by turning the rapid feed outer tube and the tapping feed counterclockwise until they run out of travel.
- 8.3 Attach tapping machine to the PE branch saddle using the tapping adapter and split backup ring kit.
 - 8.3.1 Verify that the gasket is in position between tapping adapter and the flange of the PE branch saddle.
- 8.4 Support tapping machine with a fixed source to ensure proper alignment with the PE branch saddle during the tap.
- 8.5 Install testing equipment on tapping adapter for pressure test.

- 8.6 Open the valve on the PE branch saddle.
- 8.7 Leak test the fitting and tapping machine assembly for 10 minutes at the current operating pressure of the line pipe on which the fitting is attached.

The TDW PE branch saddle is pressure tested by the manufacturer and does not require a pressure test.

- 8.8 Using a leak detection solution, test the electrofusion saddle portion of the PE branch saddle.
- 8.9 Using the valve on the testing assembly, release the test medium from fitting.

9.0 Tapping Operation

- 9.1 Verify that the rapid feed outer tube is not locked.
 - 9.1.1 When unlocked, the line on locking knob is perpendicular to machine.
 - 9.1.2 If locked, pull the locking knob out and turn the knob until line on knob is perpendicular to machine.
- 9.2 Advance the rapid feed outer tube until the pilot touches the pipe. It should be full travel as the pilot touches pipe.

Be aware of the cutter possibly "catching" during the rapid feed advancement.

- 9.3 Lock the rapid feed outer tube by turning locking knob until the line on knob is parallel with the machine.
 - 9.3.1 It may be necessary to move the outer tube back and forth until the tapping feed locks.
- 9.4 Using the star handle, advance the tapping feed manually. Turn the star handle at a moderate, steady pace.

Do not use an air drive motor.

- 9.5 The handle should turn noticeably easier when the tap is complete. Be sure to constantly support the tapping machine during the tapping operation to ensure proper alignment of the cutter.
- 9.6 Once the tap is complete, unlock the rapid feed outer tube by pulling the locking knob out and turning the knob until line on knob is perpendicular to the machine.
- 9.7 Back the cutter out using the rapid feed outer tube.

DO NOT use the tapping feed first to back out the cutter.
Backing the cutter out using the tapping feed *before* the outer tube could unthread the coupon.

9.8 Once the outer tube is backed all the way out, back out the tapping feed.

10.0 Completion Operation

10.1 Using the valve on the testing assembly, purge the air from the fitting.

10.2 Close the valve on the PE branch saddle.

10.3 Using the valve on the testing assembly, bleed the pressure off the PE branch saddle.

10.4 Remove the tapping machine from the PE branch saddle.

10.5 Verify that the coupon is in the cutter. If the coupon is not in the cutter, reattach the tapping machine and repeat the Tapping Operation steps above.

10.6 Once the coupon is secured, cut the flange off the PE branch saddle, doing so at the butt fusion connecting the flange to valve.

10.7 If the PE branch saddle is connected by electrofusion, then use a Central Plastics half-moon scraper to scrape the outlet side of valve the full length of pup.

1. Currently, the Central Plastics half-moon scraper is the only scraper which will allow a full scrape of the outlet pup for an electrofusion coupling. The half-moon scraper comes with the tapping equipment and shall remain with the equipment.
2. The Central Plastic half-moon scrapers have been removed from general use in all operating areas.

10.8 Remove the clamp holding the saddle to the existing main.

10.9 Follow the proper electrofusion procedure or butt fusion procedure to tie the PE branch saddle into the new piping.

10.10 Leak test the final tie-in connection with leak detection solution or leak detection instrument. For leak testing, see [PTST 1, Section 12.0](#), Tie-In Joints.

End of Instructions.

Operator Qualification (OQ) Required?

YES

0561: Pressure Test - Nonliquid Medium-MAOP Less than 100 Psi

0591: Leak Test at Operating Pressure

0641: Visually Inspect Pipe and Components Prior to Installation

1091: Tapping a Pipeline (Tap Diameter Greater Than 2 Inch

1101: Tapping a Pipeline with a Built-In Cutter

UNCONTROLLED IF PRINTED

Appendices

NONE.

Attachments

NONE.

Compliance Requirements

49 CFR Part 192, specifically, §§ 192.151 and 192.627, plus Subparts F and J

Reference Documents

[POLY 2.5 Polyethylene Pipe: Electrofusion](#)

[PTST 1 Pressure Testing: Requirements](#)

[TAPS 1 Tapping and Stopping: Requirements](#)

[TAPS 3 Tapping and Stopping: Forms and Reference Materials](#)

Document Rescission

TAPS 2.7 Tapping and Stopping: TDW PE Branch Saddle Valve, October 1, 2020

Revision Notes

Location of Changes	Summary of Changes
Subsection 4.5	New - TDW PE Branch Saddle-Valve can only be installed on PE systems with Design MAOP of 100 psig or less due to the manufacturer's pressure rating.
Subsection 4.6	New - Ensure fire extinguisher is present at the location where the work is being performed.
Subsection 6.1 – Table 1	Corrected 4" description to match EMPRV and MRC

TAPPING AND STOPPING

October 1, 2022

TAPS 2.8 Shim Installation

1.0 Purpose

This document details the material and instructions for installing shims on odd sizes of steel pipe to allow installation of standard size full encirclement line stopper fittings.

2.0 Scope

This document addresses the following:

[3.0 Target Audience](#)[4.0 General](#)[5.0 Shims](#)[6.0 Shim Placement](#)[7.0 Shim Welding](#)[8.0 Weld the Line Stopper](#)[9.0 Welding Shim to Pipe](#)[10.0 Testing](#)**3.0 Target Audience**

- Gas Engineering
- Gas Tech Engineering (GTE)
- Gas Storage Engineering (GSE)
- Gas Supervisors
- Gas Field Personnel – Welders
- Gas Tech Services (GTS) – Personnel
- Gas Storage Field Personnel
- Gas Construction Services Supervisors
- Contract Gas Construction Supervisors
- Contract Gas Construction Company Welders
- Contract Construction Inspectors

4.0 General

- 4.1 Ameren Illinois (AIC) has odd sizes of steel pipe installed within its gas systems, such as: 1-1/4", 1-1/2", 3" and 7".
- 4.2 Installation of standard sizes of full encirclement line stopper fittings on these odd pipe sizes requires the use of approved steel shims. Common examples are:
 - 4.2.1 2-inch line stopper on 1-1/4-inch or 1-1/2-inch pipe.
 - 4.2.2 4-inch line stopper on 3-inch pipe.
 - 4.2.3 8-inch line stopper on 7-inch-pipe.
- 4.3 Approved shims currently stocked by AIC are:

UNCONTROLLED IF PRINTED

4.3.1 2-inch shim for 1-1/4-inch pipe – Stock Code 19 83 124,

4.3.2 8-inch shim for 7 inch-pipe – Stock Code 19 83 126.

AIC does stock some 4-inch Mueller fittings that are modified to fit 3-inch steel pipe. See [TAPS 2.4 Appendix A](#) Mueller Stopper Fittings

4.4 Gas Engineering, GTE or GSE shall work with Gas Standards and Welding Administrator to get other sizes of shims approved prior to installation.

5.0 Shims

5.1 The shim shall be a split sleeve, full encirclement with a beveled longitudinal seam which provides a good root opening of $1/16" \pm 1/32"$.

5.2 Each shim half should have a 30-degree bevel on the longitudinal seam for the root opening.

5.3 One end of the shim should have a flat face and the other end can be flat or beveled. Figure 1

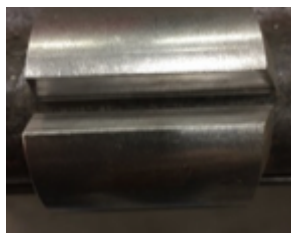

Figure 1

5.4 Shims shall be checked for proper thickness prior to installation

6.0 Shim Placement

6.1 The shims shall be placed on the pipe to allow sufficient space for the tapping tool to cut through the pipe without encountering the shims.

6.2 If one end of the shim is beveled, it shall be pointed inward.

6.3 The flat end of the shim shall be pointed outward.

6.4 There shall be a good root opening in the longitudinal seams. Figure 2.



Figure 2

6.5 Place the stopper fitting on the pipe.

- 6.6 The shim should extend beyond the end of the line stopper fitting to allow for a minimum of 1 inch space between the fillet weld on the end of the shim and the end of the stopper fitting. Figure 3.

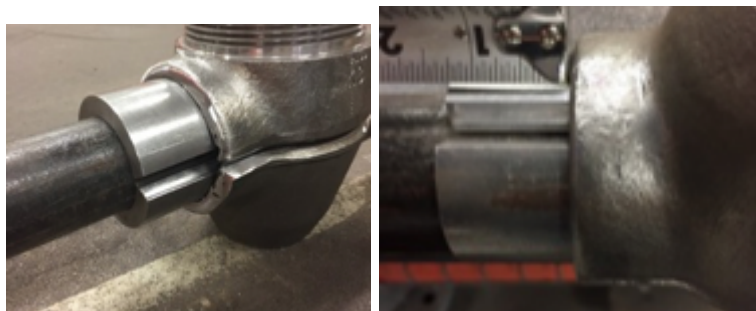

Figure 3

- 6.7 There shall be a good root opening in the longitudinal seams.
- 6.8 Use backing strips when required by fitting manufacturer.
- 6.9 Mark the shim location on the pipe and fitting location on the shim.
- 6.10 Remove the stopper fitting.

7.0 Shim Welding

- 7.1 Shims shall be correctly placed on the pipe according to previous marks. Refer to [Section 6.0](#) Shim Placement.
- 7.2 Weld the longitudinal seam but **do not weld the shim to the pipe**. This allows for thermal expansion.
- 7.3 Using a grinder flush the long seam welds to the outer wall thickness of the shim. Figure 4.



Figure 4

- 7.4 **Do not fillet weld the shim ends.**

8.0 Weld the Line Stopper

- 8.1 Place the line stopper fitting over the shims.
- 8.2 Weld the longitudinal seam of the line stopper fitting.
- 8.2.1 Make a weld pass on each side until weld is completed.
- 8.2.2 This weld can go onto the shim stock. Figure 6.



Figure 6

8.3 Weld the longitudinal seams together. Figure 7.



Figure 7

8.4 Fillet weld one end of the line stopper fitting to the shim stock.

8.5 Fillet weld the other end of the line stopper fitting to the shim stock. Figure 8.

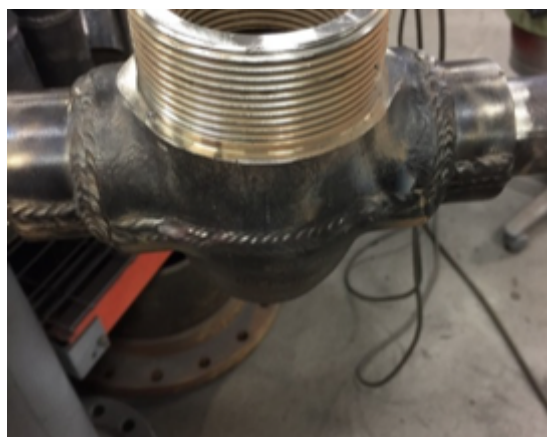

Figure 8

8.6 Do not fillet weld the shim stock to the pipe yet. Thermal expansion is still needed so allow the line stopper fitting to cool.

9.0 Welding Shim to Pipe

9.1 Clean the pipe before welding the shim to the pipe. Figure 9.



Figure 9

- 9.2 Preheat the pipe if required.
- 9.3 Fillet weld one shim to the pipe and then the other shim.
- 9.4 Clean the fillet as it is being applied and after completion.
- 9.5 Visually inspect the weld during and after application.
- 9.6 Engineering will specify if NDT is required.
- 9.7 Mark your welding ID on the weld you made.

10.0 Testing

- 10.1 Leak test the line stopper fitting connections after the fitting has cooled and before tapping. Refer to [PTST 1 Subsection 13.1](#) checking component for leaks.

Prior to tapping, confirm travel distance of tapping and stopping machine to compensate for the thickness of the shim.

- 10.2 Leak test the weld after tapping and normal operating pressure has been applied. Refer to [WELD 2.4 Paragraph 8.6.3](#) Test Time Period.

End of Instructions.

Operator Qualification (OQ) Required?

YES

0801: Welding

0811: Visual Inspection of Welding and Welds

Appendices

NONE.

Attachments

NONE.

Compliance Requirements

49 CFR Part 192 – Subpart E Welding of Steel in Pipelines

UNCONTROLLED IF PRINTED

American Petroleum Institute (API), Std 1104, "Standard for Welding Pipelines and Related Facilities", with Appendix B, "In-Service Welding"

Reference Documents

[WELD 2.4 Welding: In-Service Welding](#)

Document Rescission

NONE

Revision Notes

Location of Changes	Summary of Changes
Not Applicable	New Document

TAPPING AND STOPPING

October 1, 2022

TAPS 3 Forms and Reference Materials

Click on the links below to open the documents.

Forms

1. [Tapping Request Form \(Form Number 5742 NS\)](#)

References

1. [Dresser Style 2275 Stop Changer Manual](#)
2. [Dresser Meter Valve Changer Operating Instructions](#)
3. [GFCP Punch Tee with Transition](#)
4. [Mueller NO-BLOW Valve Changers Operating Instructions \(Rev 01/15\)](#)
5. [Mueller NO-BLOW Inspection Flange Assembly Instructions](#)
6. [Mueller 1/2" CTS Plugging Unit Operating Instructions](#)
7. [Mueller D-5 and E-5 Drilling Machine Operating Instructions](#)
8. [Mueller DH-5 and EH-5 Drilling Machine Operating Instructions](#)
9. [Mueller C1-36 Drilling Machine Operating Instructions](#)
10. [Mueller Low Pressure Line Stopper Fittings Operating Instructions](#)
11. [Mueller Line Stopper Unit No 1 Operating Instructions](#)
12. [Mueller Line Stopper Unit No. 2 Operating Instructions](#)
13. [Mueller Line Stopper Unit No. 3 Operating Instructions](#)
14. [Mueller Line Stopper Unit No. 3SW Operating Instructions](#)
15. [Mueller Line Stopper Unit No. 3SW-500 Operating Instructions](#)
16. [Mueller Line Stopper Unit No. 4SW Operating Instructions](#)
17. [Mueller Spherical Line Stopper Fitting Installation Instructions](#)
18. [Mueller Welding and Torch Cutting Instructions](#)
19. [Mueller Reassembly Instructions for Polyurethane Covered Steel Wedge Stoppers](#)
20. [Mueller AUTOPERF Tee Installation Instructions](#)
21. [Mueller Service Tee Operating Instructions](#)
22. [Mueller H-17045 Steel Service Tee Stopping Instructions](#)
23. [TDW Hot Tapping and Stopple Pipe Plugging](#)
24. [TDW T-18a Shortcutt Drilling Machine Instructions](#)
25. [TDW T-101 Drilling Machine Instructions](#)
26. [TDW T-101b, T-101b-XL Drilling Machine Instructions](#)
27. [TDW Shortstopp II Plugging Systems](#)

UNCONTROLLED IF PRINTED

28. [TDW Shortstopp II Plugging System 1.25 - 2 Inch Fittings Instructions](#)
29. [TDW Shortstopp II Plugging System 3 - 3 x 4 Inch Fittings Instructions](#)
30. [TDW Shortstopp 60 Plugging Machines 1.25 - 12 Inch Fittings](#)
31. [TDW Shortstopp 60 Plugging Machines 1.25 - 3 Inch Fittings Instructions](#)
32. [TDW Shortstopp 60 Plugging Machines 4 - 12 Inch Fittings Instructions](#)
33. [TDW Shortstopp 275 Plugging System Instructions](#)
34. [TDW Shortstopp 500 Plugging Machines 2 - 8 Inch Fittings Instructions](#)
35. [TDW Model 660a = 760a Tapping Machine, Hydraulic & Air Motor Drive](#)
36. [TDW Sandwich Valve 4 - 22 Inch Manually Operated](#)
37. [TDW Measurement Card](#)
38. [TDW TDXX and TD1XX Drilling Machines Models 6" – 14"](#)
39. [TDW Shortstopp 275 and 500 Measurement Card](#)
40. [TDW Shortstopp II 1.25 to 3 inch Measurement Card](#)
41. [TDW Shortstopp II 4 to 12 inch Measurement Card](#)

End of Section.

Document Rescission

TAPS 3 Tapping and Stopping: Forms and Reference Materials, December 15, 2021

Revision Notes

Location of Changes	Summary of Changes
Reference Materials	Added Measurement Cards for TDW Shortstopp 275 – 500, Shortstopp II 1.25 to 3 inch, and Shortstopp II 4 to 12 inch machines.

TURN- Turn-on Turn-off

TURN-ON TURN-OFF

October 1, 2022

TURN 0 Table of Contents

[TURN 1 Turn-On Turn Off: Requirements](#)

- Section 1.0 Purpose
- Section 2.0 Scope
- Section 3.0 Target Audience
- Section 4.0 Objective
- Section 5.0 Manufactured Homes
- Operator Qualification
- Compliance Requirements
- Reference Documents
- Document Rescission

[TURN 2.1 Turn-On Turn Off: Residential/Small Commercial Customer](#)

- Section 1.0 Purpose
- Section 2.0 Scope
- Section 3.0 Target Audience
- Section 4.0 General
- Section 5.0 Care and Handling of Meters
- Section 6.0 New Service Connect
- Section 7.0 Existing Service Connect
- Section 8.0 Low Flow and Five (5) Minute Shut-in Test
- Section 9.0 Regulator Set Pressure and Lockup Check
- Section 10.0 Checking Fuel Lines
- Section 11.0 Displacement of Air in Fuel Lines
- Section 12.0 Lighting Appliances
- Section 13.0 Crawl Spaces
- Section 14.0 Re-establishing Service After Flooding
- Section 15.0 Gas Meter Relight Tag
- Section 16.0 Records
- Operator Qualification

UNCONTROLLED IF PRINTED

Appendices

Appendix A - Gas Meter Relight Tag

Appendix B - Door Hanger

Compliance Requirements

Reference Documents

Document Rescission

TURN 2.2 Turn-On Turn Off: Large Commercial/Industrial Customer

Section 1.0 Purpose

Section 2.0 Scope

Section 3.0 Target Audience

Section 4.0 General

Section 5.0 Care and Handling of Meters and Correctors

Section 6.0 New Meter Installation

Section 7.0 Existing Meter Installation

Section 8.0 Initiating Service

Section 9.0 Records

Operator Qualification

Compliance Requirements

Reference Documents

Document Rescission

TURN 2.3 Turn-On Turn Off: Discontinuance or Transfer of Gas Service

Section 1.0 Purpose

Section 2.0 Scope

Section 3.0 Target Audience

Section 4.0 General

Section 5.0 Read In-Read Out

Section 6.0 Soft Disconnect (Leave Hot)

Section 7.0 Hard Disconnect (Terminate Service)

Operator Qualification

Compliance Requirements

Reference Documents

Document Rescission

TURN 2.4 Turn-On Turn Off: Lighting Appliances and Checking Appliance Safety

- Section 1.0 Purpose
- Section 2.0 Scope
- Section 3.0 Target Audience
- Section 4.0 Lighting Appliances: Stoves (Ranges)
- Section 5.0 Lighting Appliances: Water Heaters
- Section 6.0 Lighting Appliances: Furnaces
- Section 7.0 Residential Boilers
- Section 8.0 Vent-Free Appliances
- Section 9.0 Flame Characteristics
- Section 10.0 Appliance Safety
- Operator Qualification
- Compliance Requirements
- Reference Documents
- Document Rescission

TURN 2.5 Turn-On Turn Off: Combustion and Ventilation Air and Venting Requirements

- Section 1.0 Purpose
- Section 2.0 Scope
- Section 3.0 Target Audience
- Section 4.0 Combustion and Ventilation Air
- Section 5.0 Venting
- Operator Qualification
- Compliance Requirements
- Reference Documents
- Document Rescission

TURN 2.6 Turn-On Turn Off: Corrugated Stainless Steel Tubing - CSST

- Section 1.0 Purpose
- Section 2.0 Scope
- Section 3.0 Target Audience
- Section 4.0 General
- Section 5.0 Inside Installation
- Section 6.0 Outside Installation
- Operator Qualification
- Compliance Requirements
- Reference Documents

Document Rescission

TURN 2.7 Turn-On Turn Off: Warning Tag

Section 1.0 Purpose

Section 2.0 Scope

Section 3.0 Target Audience

Section 4.0 General

Section 5.0 Inspecting Customer Piping and Appliances

Section 6.0 Manufactured Housing

Section 7.0 Isolating an Appliance

Section 8.0 Code Violations

Section 9.0 Hazardous Conditions

Section 10.0 Customer Mailing

Section 11.0 Records

Operator Qualification

Appendices

Appendix A - Warning Tag (Stock Code 16-01-263)

Appendix B - CSS-Generated Customer Letter

Compliance Requirements

Reference Documents

Document Rescission

TURN 2.8 Turn-On Turn Off: Changing Meter Valves

Section 1.0 Purpose

Section 2.0 Scope

Section 3.0 Target Audience

Section 4.0 General

Section 5.0 Method 1: NO-BLO Changer

Section 6.0 Method 2: Operating Property Line Valve

Section 7.0 Method 3: Activating an EFV

Section 8.0 Method 4: Excavating and Squeezing PE Pipe

Section 9.0 Method 5: Excavating the Service Tee

Section 10.0 Method 6: Installing Control Fitting

Section 11.0 Method 7: "On-The-Fly"

Operator Qualification

Compliance Requirements

Reference Documents

UNCONTROLLED IF PRINTED

Document Rescission

TURN 2.9 Turn-On Turn Off: Brass Appliance Connectors

Section 1.0 Purpose

Section 2.0 Scope

Section 3.0 Target Audience

Section 4.0 General

Section 5.0 Uncoated Brass Connectors Found in Service

Operator Qualification

Appendices

Appendix A - CPSC Safety Alert

Compliance Requirements

Reference Documents

Document Rescission

TURN 2.10 Turn-On Turn Off: Carbon Monoxide Investigation

Section 1.0 Purpose

Section 2.0 Scope

Section 3.0 Target Audience

Section 4.0 General

Section 5.0 Upon Arrival at the Site

Section 6.0 CO Investigation

Section 7.0 CO Checks at Appliances

Section 8.0 Determining a CO Hazard

Section 9.0 Potential Effects of Carbon Monoxide Exposure

Operator Qualification

Compliance Requirements

Reference Documents

Document Rescission

End Table of Contents.

Document Rescission

TURN 0 Turn-On Turn-Off: Table of Contents, October 1, 2020

Revision Notes

Location of Changes	Summary of Changes
---------------------	--------------------

TURN 2.4 – Lighting Appliances	Inserted a New Section 8.0 – Residential Boilers Shifted Section 9.0 Flame Characteristics Shifted Section 10.0 Appliance Safety
--------------------------------	--

TURN 1 Requirements

1.0 Purpose

This document describes requirements for safely establishing (turn-on) and terminating (turn-off) natural gas service to Ameren Illinois (AIC) customers.

2.0 Scope

This document addresses the following:

[3.0 Target Audience](#)

[4.0 Objective](#)

[5.0 Manufactured Homes](#)

3.0 Target Audience

- Gas Field Personnel
- Gas Supervisors
- Meter Changers
- Meter Specialists

4.0 Objective

4.1 When gas field personnel turn on the gas service and light the appliances, they must ensure that customer's gas appliances and facilities are operating in a safe and proper manner, complying with:

- 4.1.1 NFPA 54 (National Fuel Gas Code)
- 4.1.2 HUD Title 24 (Code for Manufactured Home)
- 4.1.3 Applicable local codes

4.2 NFPA 54 Code is available in all AIC Gas Operating Centers as reference material for gas field personnel.

5.0 Manufactured Homes

- 5.1 HUD Title 24, 24 CFR Part 3280, (Code of Manufactured Home) regulates the initial manufacturing process and the initial installation of gas appliances.
- 5.2 Gas appliances initially installed, prior to first consumer sale, in a HUD approved manufactured home do not have to comply with NFPA 54.
- 5.3 Appliances installed in a manufactured home after the initial consumer sale shall be listed/or approved for installation in a manufactured home and comply with the NFPA 54 Code or the appliance manufacturer's instructions.

End of Instructions.

Operator Qualification (OQ) Required?

YES

A001: Service Reconnect

Appendices

UNCONTROLLED IF PRINTED

NONE.

Attachments

NONE.

Compliance Requirements

NFPA 54 (National Fuel Gas Code)

HUD Title 24, 24 CFR Part 3280 (Code for Manufactured Home)

Local Codes (as applicable)

Reference Documents

HUD Title 24, 24 CFR Part 3280 (online [here](#))

Document Rescission

TURN 1 Turn-On Turn-Off: Requirements, October 15, 2018.

Revision Notes

Location of Changes	Summary of Changes
Not applicable.	This is a new document.

TURN-ON TURN-OFF

TURN 2.1 Residential/Small Commercial Customer

1.0 Purpose

This document outlines the procedures for initiating gas service to a residential or small commercial customer

2.0 Scope

This document addresses the following:

[3.0 Target Audience](#)

[4.0 General](#)

[5.0 Care and Handling of Meters](#)

[6.0 New Service Connect](#)

[7.0 Existing Service Connect](#)

[8.0 Low Flow and Five \(5\) Minute Shut-in Test](#)

[9.0 Regulator Set Pressure and Lockup Check](#)

[10.0 Checking Fuel Lines](#)

[11.0 Displacement of Air in Fuel Lines](#)

[12.0 Lighting Appliances](#)

[13.0 Crawl Spaces](#)

[14.0 Re-establishing Service After Flooding](#)

[15.0 Gas Meter Relight Tag](#)

[16.0 Records](#)

Appendices:

[Appendix A - Gas Meter Relight Tag](#)

[Appendix B - Door Hanger](#)

3.0 Target Audience

- Gas Field Personnel
- Gas Supervisors
- Meter Changers
- Meter Specialists

4.0 General

4.1 The installing contractor (or designee) shall perform first time light-up on new or repaired appliances.

5.0 Care and Handling of Meters

5.1 Meter hubs shall be coated with No-Oxide grease when meter is installed.

5.2 Meters and correcting devices removed from service shall be treated the same as those to be installed.

UNCONTROLLED IF PRINTED

5.3 See [METR 1 Section 5.0](#) Care and Handling for further discussion.

6.0 New Service Connect

- 6.1 All new service connects require a check of regulator set pressure and lock-up.
- 6.2 A gas meter should be installed at the same time as the service as long as the structure is framed out. The outlet of the meter bar should have:
- 6.2.1 A closed Customer Convenience Valve (CCV) installed and plugged with the meter valve left in the "on" position, or
 - 6.2.2 If a CCV is **not** installed, then the meter valve shall be locked in the "off" position.
- 6.3 The installing contractor (or designee) shall perform first time light-up on new or repaired appliances. Ameren Illinois (AIC) personnel should not perform this first time "light-up" on newly installed or repaired equipment.

7.0 Existing Service Connect

Stray electrical current migrating from various sources can energize meter set and customer's piping, creating a hazardous work environment.

- 7.1 Before touching the meter set, check for the possibility of AC voltage with a "volt stick".
- 7.1.1 **If voltage is detected, do not make contact.** Notify the Gas Supervisor to initiate an investigation of the voltage source before performing any additional work on energized section. See [METR 2.2 Section 7.2](#) AC Voltage on Meter Set.
- 7.2 Check the gas meter number to confirm correct address.
- 7.3 Perform Meter Header Inspection. See [METR 2.2 Section 7.0](#).
- 7.4 Customer Choice - Customer Relights Appliances

A customer **should not** be allowed the option of lighting their own appliance when there is a known documented hazard.

- 7.4.1 *Customer is home and shut-in test passes:*
- 1. Leave meter valve in the "on" position.
 - 2. Notify customer gas is on and ready for use.
- 7.4.2 *Customer is home but shut-in test fails:*
- 1. Perform an investigation to determine cause of movement.
 - 2. If leak is found, isolate in accordance with [LEAK 2.1 Section 9.0](#) Leak on Customer Facility.
 - 3. Notify the customer of the source of the leak and that they are responsible for repair.

4. If the leak is isolated at the valve downstream of the meter outlet or at the appliance control valve, then leave the meter valve in the "on" position and give customer a Meter Relight Tag. ([Appendix A](#)).

7.4.3 Customer is **not** at home or unavailable:

1. Perform a low flow test and 5-minute shut-in test on customer piping. If shut-in test passes:
 - 1 a. If there is a CCV downstream of the meter bar, turn off the valve and leave a Meter Relight Tag, or
 - 1 b. If possible, install a CCV downstream of meter bar, leave valve in off position and leave a Meter Relight Tag, or
 - 1 c. If CCV does not exist, leave off and locked at the meter valve. Leave a door hanger advising the customer to call and reschedule.
2. *If shut-in test fails*, turn off and lock the meter valve. Leave a door hanger advising the customer to call and reschedule ([Appendix B](#)).

7.5 Customer Choice - AIC Relights Appliances

7.5.1 All connected appliances shall be checked for proper installation and operation whenever the customer chooses to have AIC relight the appliances. The installing contractor (or designee) shall perform first time light-up on new or repaired appliances.

7.5.2 If the customer chooses to have AIC relight the appliances, gas field personnel shall:

1. Check to ensure access to the appliances is available. If not, leave a door tag advising customer to call and reschedule a connect.
2. Perform a low flow test and 5-minute shut-in test on customer piping. See Low Flow and Five (5) Minute Shut-in Test ([Section 8.0](#)).
3. If movement is detected, perform an investigation to determine source of movement.
4. Access the structure and inspect the piping and appliance for proper installation.
5. Light any existing appliances and check for proper operation.

8.0 Low Flow and Five (5) Minute Shut-in Test

8.1 A low flow test is performed by allowing gas to flow downstream of the meter. After confirming the meter will register low flow, proceed with the shut-in test.

8.1.1 During low flow test, if odorant is not readily detectable, verbally notify Gas Supervisor immediately for a follow-up investigation. See [ODOR 2.1 Section 9.0](#) Odorant Intensity Testing Sniff Tests.

8.2 Perform a 5-minute shut-in test using the normal delivery pressure to ensure the customer piping has no leaks. A shut-in test may be performed using a gas meter test hand or a pressure gauge assembly.

8.3 Using Gas Meter Test Hand:

8.3.1 Unlock meter valve, turn on gas. If fast movement on the test hand is detected, turn the meter valve off and check for failed safeties and/or open fuel lines.

- 8.3.2 With the test hand on the upstroke, perform the shut-in test. Refer to Section 8.3.3 for meters equipped with remote meter reading modules.
- 8.3.3 Mark position of test hand.
 1. When performing the low flow test, wait until the test hand has jumped ahead and resumed movement before tightening the outlet swivel meter nut.
 2. Note the following guidance on "slight movement" of the meter test hand and refer to [Figure 1](#):
 - 2 a. As a guide, if the quarter- or half-foot test hand moves from one tick mark, on the circle, to the next tick mark in 5 minutes or longer this would be considered slight movement.
 - 2 b. If gas field personnel feel more comfortable in turning off all pilots before conducting the 5-minute shut-in test, that is their choice.
 - 2 c. If all the pilots are turned off, then there should be no movement in the test hand.

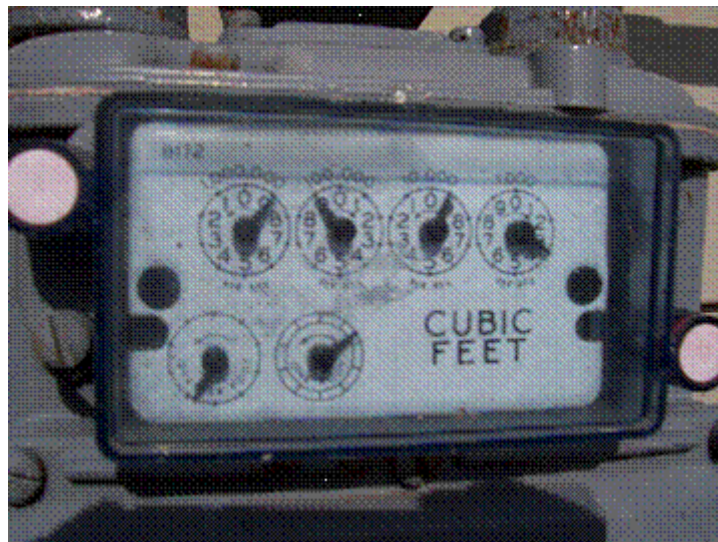

Figure 1: Gas Meter Index (Test hands at lower left)

- 8.3.4 Perform a 5-minute shut-in test by observing the meter test hand while the gas is on and all appliances are turned off.
 1. *If slight movement of the meter test hand is detected AND the customer is home:*
 - 1 a. Ensure that customer appliances have standing pilots.
 - (i) If not, then perform an investigation to determine source of movement. Make simple repairs OR issue a **"Warning"** tag.
 2. *If slight movement of the meter test hand is detected AND the customer is not home:*
 - 2 a. Lock the meter valve and complete the order, "Red Pin".
 - 2 b. Leave a door tag so the customer knows why their service is off and whom to call to restore service.
 - 2 c. Document the finding.
- 8.3.5 Check meter set fittings for leaks and repair any leak found.

8.4 Using a Pressure Gauge Assembly:

- 8.4.1 Unlock the meter valve, turn gas on and check for movement of the test hand on the meter index.
- 8.4.2 If fast test hand movement is detected, turn the meter valve off and check for failed safeties and/or open fuel lines.
- 8.4.3 Turn meter valve off and loosen the inlet and outlet meter swivel nuts to remove the meter.
- 8.4.4 Connect the pressure gauge assembly to the inlet and outlet meter swivel nuts.
- 8.4.5 Turn the meter valve on to pressurize the assembly and customer piping.
- 8.4.6 Soap the meter set fittings and repair any leaks found.
- 8.4.7 Turn the pressure gauge valve to the off position.
- 8.4.8 Perform a 5-minute shut-in test by observing the pointer on the pressure gauge.
- 8.4.9 If a slight loss in pressure is detected, ensure that the customer appliances have standing pilots. If not, then perform an investigation and make any necessary repairs OR issue a "**Warning**" tag.
 1. *If the customer is home:*
 - 1 a. Ensure that customer appliances have standing pilots.
 - (i) If not, then perform an investigation to determine source of movement. Make simple repairs or issue a "**Warning**" tag.
 2. *If the customer is **not** home:*
 - 2 a. Lock the meter valve and complete the order, "Red Pin".
 - 2 b. Leave a door tag so the customer knows why their service is off and whom to call to have service restored.
 - 2 c. Document the finding.

9.0 Regulator Set Pressure and Lockup Check

- 9.1 If the turn on includes a service regulator change, meter change, or meter install, then include a regulator set pressure and lock-up test using the following procedure:
 - 9.1.1 Downstream of the meter, install a meter test plug or fitting that contains an orifice and a connection for an inches gauge.

Service regulators are set at 7 inches water column (W.C.) with a flow rate of 50 CFH. An orifice drilled with a #33 size bit will provide the correct CFH at 7 inches W.C.
 - 9.1.2 Turn gas on and set the delivery pressure of the regulator with gas flowing through test fitting orifice. Normal residential delivery pressure is 7 inches W.C.
 - 9.1.3 After the correct pressure has been established, check lock-up of the regulator by stopping the gas flow through the orifice with your finger.
 - 9.1.4 The regulator should lock-up at no more than 1 inch W.C. higher than the delivery set point of 7 inches W.C.

UNCONTROLLED IF PRINTED

- 9.1.5 Elevated delivery pressure customers will require a test gauge or better to set delivery pressure and check lockup of regulator. See [METR 2.6](#) Pressure Gauges and [METR 2.8](#) Pressure Factor Metering.

10.0 Checking Fuel Lines

- 10.1 Gain access to the premise. If the premise is a health or safety hazard, notify your Supervisor.
- 10.2 If accessible, check where the fuel line enters the structure.
- 10.3 Trace all visible fuel lines and check for code violations and hazards. See [TURN 2.7](#) Warning Tag.
- 10.4 All fuel lines should be supported.
- 10.5 Any fuel lines that are not connected to an appliance shall be capped or plugged.
- 10.6 Check each gas appliance for an accessible shut-off valve or a listed gas convenience outlet installed in the same room/floor and within 6 feet of the appliance it serves. Existing appliances without a shut-off valve may be lit. However, a **"Warning"** tag should be issued.
- 10.7 All water heaters and furnaces should have a sediment trap. Existing appliances without a sediment trap may be lit. However, a **"Warning"** tag should be issued.

HUD does **not** require sediment trap (drip leg) at original appliances in Manufactured Homes.

- 10.8 Check for uncoated brass appliance connectors and replace when found. See [TURN 2.9](#) Brass Appliance Connectors.

11.0 Displacement of Air in Fuel Lines

- 11.1 Before bleeding, be sure to identify and eliminate all sources of ignition, such as standing pilots, open flames, cigarettes, appliances and equipment.
- 11.2 When displacing, bleeding, air in customer fuel lines:
- 11.2.1 Do not bleed the air/gas mixture into a confined space.
- 11.2.2 All bleeding of air/gas should only be done in a well-ventilated area or by venting the air/gas into the outside atmosphere.
- 11.3 The safest way to bleed a customer fuel line is at the gas stove but if not available can be bled at the water heater or furnace by holding down the pilot button to bleed the air through the pilot.

Overriding any appliance safety is an unsafe act and shall not be performed.

- 11.4 Another option for bleeding the customer fuel line is to:
- 11.4.1 Shut off the appliance valve upstream of the fuel line union, flex connector or sediment trap.

11.4.2 Loosen the union, flex connector or drip leg cap; however, never completely disconnect the piping or remove the cap.

11.4.3 Turn on the appliance valve and bleed the air/gas mixture through the loosened fitting.

11.4.4 When gas odor is first detected, tighten the fitting and soap test for leaks. With a gas detection instrument, check the area to ensure a hazardous environment has not been created by bleeding the fuel line.

11.5 High efficiency sealed combustion units may be used to bleed the customer fuel line by cycling the appliance several times. If the appliance does not light, the unit may lock out and require the power supply to be interrupted for 60 seconds to reset the appliance controls.

12.0 Lighting Appliances

12.1 Gas range

12.1.1 Complete a visual inspection and operational check of the range. See [TURN 2.4 Section 4.0](#) Lighting Appliances: Stoves (Ranges).

12.2 Water heater

12.2.1 First verify that the water is turned on. If water does not come out of the hot- and cold-water faucet, do not light the water heater. Complete an inspection and operational check of the water heater. See [TURN 2.4 Section 5.0](#) Lighting Appliances: Water Heaters.

12.2.2 If the water in the heater is frozen, do not light. Leave off and issue "Warning" tag as Hazardous Condition.

12.2.3 If there is a possibility that the water pipes are frozen, notify the customer of possible leakage when water pipes thaw and that Ameren Illinois is not responsible for damage.

12.3 Gas furnace

12.3.1 Complete an inspection and operational check of the furnace. See [TURN 2.4 Section 6.0](#) Lighting Appliances: Furnaces.

12.4 Residential Boilers

12.4.1 Complete an inspection and operational check of the boiler. See [TURN 2.4 Section 7.0](#) Lighting Appliances: Residential Boilers.

12.5 Light any other existing gas appliances customer requests to be connected and complete an inspection and operational check of each appliance. If, at the customer's request, an appliance is not to be lit:

12.4.1 Appliance should be left off at the control valve and the lever handle valve, if one is present.

13.0 Crawl Spaces

13.1 Before entering the crawl space, check the environment at the entrance for the presence of gas, oxygen levels, carbon monoxide. See [CONF 1](#).

13.2 If crawl space cannot be safely entered to light an appliance, notify Gas Supervisor so arrangements can be made to light the appliance or to get assistance.

14.0 Re-establishing Service After Flooding

- 14.1 If meter and/or regulator were underwater, components should be replaced.
- 14.2 Appliances that were under water shall be "**Warning**" tagged as Hazardous Condition.
- 14.3 Gas field personnel should not perform the light up on repaired equipment.

15.0 Gas Meter Relight Tag

- 15.1 If customer has elected to relight their own appliance, gas field personnel will leave a Gas Meter Relight Tag when they have completed a successful shut in test. See [Appendix A](#) for a copy of the Gas Meter Relight Tag.
- 15.2 The Gas Meter Relight Tag provides the customer with instructions on how they can turn on their gas at the valve downstream of the meter outlet.

16.0 Records

- 16.1 Records associated with turning on gas service shall be recorded and maintained in Ameren Illinois CSS and OAS for at least 2 years.

End of Instructions.

Operator Qualification (OQ) Required?

YES

1161: Installation of Customer Meters and Regulators - Residential and Small Commercial

A001: Service Reconnect

Appendices

[Appendix A - Gas Meter Relight Tag](#)

[Appendix B - Door Hanger](#)

Attachments

NONE.

Compliance Requirements

NONE.

Reference Documents

[CONF 1 Confined Space - Requirements](#)

[LEAK 2.1 Leak Management: Indoor Investigations](#)

[METR 1 Metering: Requirements](#)

[METR 2.2 Metering: Meter Inspection and Testing: Field](#)

[METR 2.6 Metering: Pressure Gauges](#)

[METR 2.8 Metering: Pressure Factor Metering](#)

[ODOR 2.1 Odorization: Requirements](#)

[TURN 2.4 Turn-On Turn-Off: Lighting Appliances and Checking Appliance Safety](#)

[TURN 2.7 Turn-On Turn-Off: Warning Tag](#)

UNCONTROLLED IF PRINTED

TURN 2.9 Turn-On Turn-Off: Brass Appliance Connectors

Document Rescission

TURN 2.1 Turn-On Turn-Off: Residential/Small Commercial Customer, October 1, 2022

Revision Notes

Paragraph 12.4.1 – Lighting Appliances	Corrected Reference Link to TURN 2.4 Section 7.0 Residential Boiler.
--	--

Appendix A - Gas Meter Relight Tag

Stock Code 37-22-264 - Form #F5824 (Rev 8/19)

You have chosen to light your own appliances:

Please follow these steps.

1. Close all open fuel lines.
2. Slowly turn gas valve to the ON position.
3. Re-light all gas appliances.

CAUTION! Any movement of the meter hands immediately after opening valve could indicate a gas leak and you should close the gas valve and call Ameren Illinois at **1.800.755.5000**

We respond 24/7 /365 at no cost to you.



TURN VALVE 1/4 TURN SO THAT THE LOCK WING IS PARALLEL TO THE PIPE TO TURN ON GAS SERVICE

****TURN VALVE SLOWLY****

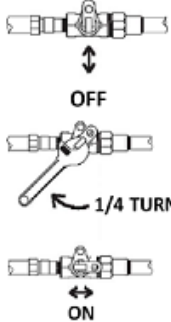

OFF

1/4 TURN

ON

Form F5943 Rev. 8/19 Stock No. 37-22-264

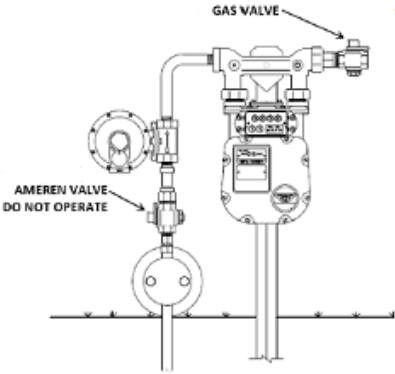

Ha decidido encender sus propios aparatos:

1. Cierre todas las líneas de combustible abiertas.
2. Gire lentamente la válvula de gas a la posición de encendido (ON).
3. Vuelva a encender todos los aparatos de gas.

PRECAUCIÓN! Cualquier movimiento de las agujas del medidor inmediatamente después de abrir la válvula puede indicar que existe un escape de gas y debe cerrar la válvula de gas y llamar a Ameren Illinois al 1.800.755.5000. Respondemos 24 horas al día, 7 días de la semana, 365 días del año sin costo alguno para usted.



GIRE LA VÁLVULA 1/4 DE VUELTA HASTA QUE LA ALETA DE LA LLAVE MARIPOSA ESTÉ PARALELA AL CAÑO PARA ABRIR EL SERVICIO DE GAS.

****GIRE LA VÁLVULA LENTAMENTE****



APAGADO

1/4 DE VUELTA

ENCENDIDO

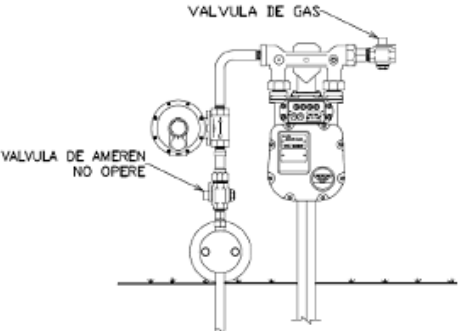

Appendix B - Door Hanger

Stock Code 37-22-292 Form #5945 (Rev. 11/19)

UNCONTROLLED IF PRINTED

Form 5346
Stock No. 37-22-292
Rev. 11/19

**Important Information About
Your Natural Gas Service**

**Your natural gas service
has been temporarily shut off
for required maintenance.**

Please schedule an appointment
with Ameren Illinois to have your
service restored by calling

877.263.7363

Representatives are available 24/7.

**Su servicio de gas se ha cerrado
temporalmente por mantenimiento.**

Programe una cita con Ameren Illinois
para restaurar su servicio llamando al

877.263.7363

Los representantes están disponibles
al cualquiera hora.



Form 5346
Stock No. 37-22-292
Rev. 11/19

**SMELL GAS?
LEAVE FAST!**



**If you smell an odor like rotten eggs in
or around your home, leave immediately
and call Ameren Illinois at**

1.800.755.5000

**At no cost, we respond 24 hours
a day, seven days a week to ensure
everyone's safety.**



1.0 Purpose

This document outlines the procedures for initiating gas service to large commercial/industrial customers.

2.0 Scope

This document addresses the following:

[3.0 Target Audience](#)

[4.0 General](#)

[5.0 Care and Handling of Meters and Correctors](#)

[6.0 New Meter Installation](#)

[7.0 Existing Meter Installation](#)

[8.0 Initiating Service](#)

[9.0 Records](#)

3.0 Target Audience

- Gas Field Personnel
- Gas Supervisors

4.0 General

- 4.1 The turn-on should be done with the assistance of the owner (or designee) who is familiar with the location and operation of all gas burning appliances.
- 4.2 Customer shall provide all necessary equipment for AIC gas field personnel to safely access the appliances for inspection and lighting. Gas field personnel are not obligated to inspect, adjust, or light appliances unless safe access is available.
- 4.3 Customer is responsible for performing light-up operations once gas field personnel have verified there are no gas leaks on customer's facilities. Gas field personnel may assist customer with the light-up when requested.
- 4.4 Gas field personnel should document on the order if customer does not provide a means of safe access or denies access to gas facilities.

5.0 Care and Handling of Meters and Correctors

- 5.1 Meters and correcting devices removed from service shall be treated the same as those to be installed.
- 5.2 See [METR 1 Section 5.0](#) Care and Handling for further discussion.

6.0 New Meter Installation

- 6.1 Large commercial/industrial installations will typically have gas loads of 15,000 scfh or greater requiring larger piping, multiple valves, larger regulators, relief valves, and possibly electronic correcting devices.

- 6.2 Newly installed meter sets shall follow standard meter set design in accordance with [METR 3.4](#) or with Gas Engineering design. Gas field personnel shall notify Gas Supervisor if this is not the case.
- 6.3 Gas field personnel shall perform a meter header inspection. See [METR 2.2 Section 7.0](#) Meter Header Inspection.
- 6.4 Gas field personnel must have information concerning the regulator set pressure, metering pressure, relief valve set pressure, meter size, and if electronic corrector is required.
- 6.5 Install the meter, if not already installed, ensuring it is level in all directions.
- 6.6 Rotary meters should be filled to the proper level with oil, or arrangements made to fill with oil shortly after turning the meter on.
- 6.7 If electronic corrector is required, it should be in place or arrangements made to have it installed as soon as meter is installed.
- 6.8 Gas field personnel should verify all connections are tight and valves are in the closed position.
- 6.9 Check vent lines for proper size and termination. See [METR 1 Section 8.0](#) Regulator Vent Lines.
- 6.10 If regulators have sensing control lines, verify they are not connected together. Each control line must have its own tap.
- 6.11 If meter is installed inside the building, ensure there is an accessible shut-off valve outside the building.
- 6.12 If regulator is installed inside the building, ensure vent line has been extended to outside the building. See [METR 1 Section 8.0](#).
- 6.13 Verify customer's shut-off valve and bypass valve (if present) are in the closed position.
- 6.14 Meter by-pass valve shall be locked in closed position.

7.0 Existing Meter Installation

- 7.1 Gas field personnel shall perform a meter header inspection. See [METR 2.2 Section 7.0](#).
- 7.2 Gas field personnel must have information concerning the regulator set pressure, metering pressure, relief valve set pressure, meter size, and if electronic corrector is required.
- 7.3 Verify all connections are tight and valves are in the closed position.
- 7.4 Check vent lines for proper size and termination. See [METR 1 Section 8.0](#).
- 7.5 If regulators have sensing control lines, verify they are not connected together. Each control line must have its own tap.
- 7.6 If meter is installed inside the building, ensure there is an accessible shut-off valve outside the building.
- 7.7 If regulator is installed inside the building, ensure vent line has been extended to outside the building. See [METR 1 Section 8.0](#).
- 7.8 Verify customer's shut-off valve and by-pass valve (if present) are in the closed position.
- 7.9 Meter by-pass valve shall be locked in closed position.

8.0 Initiating Service

- 8.1 Conduct a low flow test to ensure meter will register. Most large meter sets will have blowdown facilities downstream of meter that can be used to create flow through the meter.
 - 8.1.1 During low flow test, if odorant is not readily detectable, verbally notify Gas Supervisor immediately for a follow-up investigation. See [ODOR 2.1 Section 8.0](#) Odorant Intensity Testing Sniff Tests. Check meter set for leaks.
- 8.2 Check existing regulator pressure set point and adjust if necessary.
 - 8.2.1 If customer's gas equipment is not in operation, use blow-down facility to create flow.
 - 8.2.2 Use test gauge to set and check pressure. See [METR 2.6](#) Pressure Gauges.
 - 8.2.3 Perform a lock-up test on all new meter set installations and on existing meter sets where a new regulator has been installed.
- 8.3 If equipped with relief valve, set relief valve set pressure by either temporarily increasing regulator pressure or the use of nitrogen.

Gas field personnel should check for the presence of audible relief alarms and take necessary precautions to protect their hearing.

- 8.4 Coordinate with customer (or designee) to ensure gas appliances are in "off" position and that there are no open fuel lines.
- 8.5 Open customer valve and allow gas to fill customer's fuel lines.
- 8.6 Observe meter test hand when it stops moving. Customer's fuel line should be filled.
- 8.7 Conduct a shut-in test to check for leaks on customer's piping. It is difficult to perform shut-in test by observing the test hand of rotary meters or large diaphragm meters normally installed for large commercial/industrial customers. Rotary meters will allow an extremely low flow of gas to pass by the impellers without registering on the index. Large diaphragm meters have a larger test hand which requires a longer period of time and a higher volume of gas to pass before movement of test hand is observed.
- 8.8 For large commercial/industrial metering situations, use of a pressure gauge is the easiest method for checking customer's piping for leaks. This will require a pressure tap downstream of isolation valve.
 - 8.8.1 Once customer's fuel line has been filled, close the meter valve or the customer's shut off valve to isolate customer's piping.
 - 8.8.2 Once pressure has stabilized, record the pressure gauge reading.
 - 8.8.3 After 10 minutes, check pressure reading. A drop in pressure will indicate a leak.
- 8.9 Once no leak on customer's facilities is verified, lighting of appliances may proceed. The customer is responsible for performing light-up operations. Gas field personnel may assist customer with the light-up when requested.
- 8.10 If leakage is detected on customer facilities, issue a "**Warning**" tag.

- 8.11 If meter is operating at elevated pressure, install metering pressure tag near the meter index. See [METR 2.8](#) Pressure Factor Metering.
- 8.12 Gas Supervisor (or designee) shall notify the appropriate gas metering personnel when a rotary meter has been installed and turned-on so an initial differential test can be performed on the meter.

9.0 Records

- 9.1 Gas field personnel shall complete Gas Meter Data Sheet for all meters that operate at an elevated pressure (> 7" w.c./0.25 psig). Submit completed Gas Meter Data Sheet to Gas Supervisor for review and distribution. See [METR 2.10 Section 6.0](#) for distribution list.
- 9.2 Complete order by providing required meter information. Depending on operating procedures of the various Operating Areas, the order may be "restored" or sent to a local office OSA/OSR for completion.

End of Instructions.

Operator Qualification (OQ) Required?

YES

1171: Installing Customer Meters - Large Commercial and Industrial

Appendices

NONE.

Attachments

NONE.

Compliance Requirements

NONE.

Reference Documents

[METR 1 Metering: Requirements](#)

[METR 2.2 Metering: Meter Inspection and Testing - Field](#)

[METR 2.6 Metering: Pressure Gauges](#)

[METR 2.8 Metering: Pressure Factor Metering](#)

[METR 2.10 Metering: Gas Meter Data Sheet](#)

[METR 3.4 Metering: Compact and Rotary Meter Sets](#)

Document Rescission

TURN 2.02 Turn-On Turn-Off: Large Commercial/Industrial Customer, January 1, 2016.

Revision Notes

Location of Changes	Summary of Changes
Not applicable.	This is a new document.

UNCONTROLLED IF PRINTED

UNCONTROLLED IF PRINTED

TURN-ON TURN-OFF

TURN 2.3 Discontinuance or Transfer of Gas Service

1.0 Purpose

This document outlines the procedures for disconnecting or transferring gas service.

2.0 Scope

This document addresses the following:

[3.0 Target Audience](#)

[4.0 General](#)

[5.0 Read In-Read Out](#)

[6.0 Soft Disconnect \(Leave Hot\)](#)

[7.0 Hard Disconnect \(Terminate Service\)](#)

3.0 Target Audience

- Gas Field Personnel
- Gas Supervisors
- Meter Specialists

4.0 General

- 4.1 AIC allows for residential gas meters to be left on for a period of time following a customer's request for disconnect when the former customer is not removing a gas appliance.
- 4.2 In the following situations, gas service is shut off and locked at the meter valve:
 - 4.2.1 The customer requesting the turn-off is moving or removing a gas appliance.
 - 4.2.2 A non-pay order is issued.
 - 4.2.3 A structure is being torn down.
 - 4.2.4 The customer no longer desires natural gas service.

5.0 Read In-Read Out

- 5.1 Service may be transferred from one customer to another customer at the same location without interruption of service.
- 5.2 The meter may be "read out" of the name of the customer terminating service and "read in" the name of the new customer without turning off the meter valve or entry into the premises.
- 5.3 When a physical reading is necessary, gas field personnel shall always verify the meter number before getting the reading.

6.0 Soft Disconnect (Leave Hot)

- 6.1 When the Customer Contact Center receives a gas turn-off request and customer reports no gas appliance is being removed, obtain a reading through AMI or issue an or-

der with an MJ-15 (read meter) trouble code. The gas meter will be read and left on for 10 calendar days.

- 6.2 Gas field personnel shall always verify the meter number when performing a physical read through to ensure that they are at the correct meter.

7.0 Hard Disconnect (Terminate Service)

- 7.1 A hard disconnect order, with a trouble code DC-TM, will be issued for the following situations:
- 7.1.1 There has been no successor connected within 10 calendar days of the initial turn-off request when no gas appliance is being moved or removed (Soft Disconnect).
 - 7.1.2 In the initial turn-off request, the Customer reported that a gas appliance was being moved or removed.
 - 7.1.3 A non-pay disconnect is issued.
 - 7.1.4 Customer has request termination of service due to demolition of or damage to the structure.
 - 7.1.5 Customer no longer has gas appliances and wants the service discontinued.
- 7.2 When disconnecting gas service, leave the gas meter in place unless the customer has indicated they no longer want gas service.
- 7.2.1 Gas field personnel should report to their Supervisor if there are any indications the structure appears to be abandoned, condemned, or severely damaged or is being torn down.
 - 7.2.2 Gas Supervisor should investigate to determine if an order needs to be generated to disconnect the service line from the main.

Stray electrical current migrating from various sources can energize meter set and customer's piping, creating a hazardous work environment.

- 7.3 Before touching the meter set, check the riser, meter and customer piping with volt stick. If volt stick alarms, see [METR 2.2 Section 7.2](#) AC Voltage on Meter Set.
- 7.4 Verify the meter number.
- 7.5 Perform meter header inspection, See [METR 2.2 Section 7.0](#).
- 7.6 Close the meter valve and lock.

If piping or meter is removed, cap or plug all open ends of piping, meter, and valves.

- 7.7 Record the meter reading on the order.

End of Instructions.

UNCONTROLLED IF PRINTED

Operator Qualification (OQ) Required?

YES

A001: Service Reconnect

A002: Abandonment

Appendices

NONE.

Attachments

NONE.

Compliance Requirements

NONE.

Reference Documents

[METR 2.2 Metering: Meter Inspection and Testing - Field](#)

Document Rescission

TURN 2.3 Turn-On Turn-Off: Discontinuance or Transfer of Gas Service, April 1, 2021

Revision Notes

Location of Changes	Summary of Changes
Subsection 7.6 NOTE	Added "meter" - If piping or meter is removed, cap or plug all open ends of piping, meter and valves.

TURN 2.4 Lighting Appliances and Checking Appliance Safety

1.0 Purpose

This document specifies procedures for lighting appliances (stoves/ranges, water heaters, furnaces), installing and operating vent-free gas appliances as supplemental heat sources, and for checking the appliance safety associated with the control valve on an appliance.

2.0 Scope

This document addresses the following:

[3.0 Target Audience](#)

[4.0 Lighting Appliances: Stoves \(Ranges\)](#)

[5.0 Lighting Appliances: Water Heaters](#)

[6.0 Lighting Appliances: Furnaces](#)

[7.0 Residential Boilers](#)

[8.0 Vent-Free Appliances](#)

[9.0 Flame Characteristics](#)

[10.0 Appliance Safety](#)

3.0 Target Audience

- Gas Field Personnel
- Gas Supervisors
- Meter Changers
- Meter Specialists

4.0 Lighting Appliances: Stoves (Ranges)

4.1 General

- 4.1.1 This section outlines the procedure for a visual inspection and operational check of an existing stove after the fuel lines have been purged of air.
- 4.1.2 All new or repaired appliances shall be checked for proper installation, however, the installing contractor (or designee) shall light the appliance.

4.2 Visual Inspection

- 4.2.1 All new or replaced ranges shall have a shut off valve within 6 feet of the range and in same room.
 1. The valve shall be placed before the appliance connector.
 2. Existing ranges without a shut off valve may be lit. However, a **"Warning"** tag shall be issued. See [TURN 2.7](#) Warning Tag for list of Code Violations.
- 4.2.2 Check that all controls are in the "off" position.
- 4.2.3 Check for clearance at the bottom of range to allow for sufficient combustion air for the oven. See [TURN 2.5](#) Combustion and Ventilation Air.
 1. If the range is placed on carpet, the adjustable legs shall be extended to allow combustion air to reach the oven burners.

UNCONTROLLED IF PRINTED

2. Any rug placed in front of the range must not block combustion air for the oven.

4.2.4 Inspect customer's appliances for the presence of uncoated brass connectors each time entering a customer home or business in the normal course of their work. See [TURN 2.9](#) Brass Appliance Connectors.

4.2.5 Use special care when moving the range. If the range is connected with a brass connector that has soldered ends, movement of the connector could cause the ends to separate.

4.2.6 Connectors for gas appliances shall be used in accordance with the terms of their listing, and shall be in the same room as the equipment. Only one connector shall be used per appliance.

4.2.7 If the range was moved during the inspection, check behind the range with a gas detection instrument after the gas is turned on, to ensure that the range connector was not damaged and is not leaking.

4.3 Operational Check - Range Top Burners

4.3.1 Verify the burner valves are in the "off" position.

4.3.2 Light the range top pilots, clean and adjust if necessary.

1. On range tops, check each burner air shutter that is accessible and clean if necessary.

4.3.3 Light all burners.

4.3.4 Check for proper flame characteristics. Adjust air shutter if necessary to obtain proper flame characteristics. See [Section 9.0](#).

4.4 Operational Check - Oven Burner

4.4.1 Verify the oven control valve is in the "off" position.

4.4.2 For equipment with an appliance safety, check for proper operation.

Position your head close enough to observe main burner ignition, but at a safe distance to prevent injury from possible flame rollout.

1. Before the oven pilot is lit, position your head as close to the front of the oven compartment as the oven door will allow.

2. Turn the oven control to the full "on" position.

- 2 a. If you hear gas flowing through the main burner, then the safety has failed.

- (i) Turn off the range and issue a "**Warning**" tag. See [TURN 2.7](#). Do not operate an appliance with a malfunctioning safety. See [Section 10.0](#).

- 2 b. If you do not hear gas flowing through the main burner, then the safety is working.

3. Turn the oven control to the "off" position and light the oven pilot.

4. Turn on the oven burner control and check for proper ignition.

UNCONTROLLED IF PRINTED

- 4.4.3 Check for proper flame characteristics. Adjust air shutter if necessary to obtain proper flame characteristics. See [Section 9.0](#).
- 4.4.4 Ovens with electronic ignition should be cycled on and off to check for proper operation and flame characteristics.
 - 1. Clean or adjust air shutter, if needed and accessible, to obtain proper flame characteristics.
 - 2. Special care shall be taken when cleaning the oven burner runner slot on ranges with electronic ignition (glow plug).
 - 3. The glow plug is coated with ceramic and will break if touched or bumped.

5.0 Lighting Appliances: Water Heaters

5.1 General

- 5.1.1 This section outlines the procedure for inspection and operation of an existing water heater after the fuel lines have been purged of air.
- 5.1.2 All new or repaired appliances shall be checked for proper installation, however, the installing contractor or designee shall light the appliance.

5.2 Prohibited Installations

- 5.2.1 Water heaters in residential garages and in adjacent spaces open to the garage shall be installed so that all burners and ignition devices are at least 18 inches above the floor unless listed as Flammable Vapor Ignition Resistant.
- 5.2.2 No new or replaced water heater shall be installed in bathrooms, bedrooms, or any occupied rooms normally kept closed.
- 5.2.3 *Exceptions:*
 - 1. Direct vent, (sealed combustion chamber), water heaters that obtain outside combustion air and discharge flue gases to the outdoors.
 - 2. A water heater that is installed in a closet equipped with a weather-stripped door with a self-closing device, and all combustion air is obtained from the outdoors.

5.3 Existing Installations

- 5.3.1 When a water heater is found to be installed in a bedroom or bathroom, an operational inspection shall be performed with the door closed and the exhaust fan operating.
 - 1. If the water heater operates properly, it shall be tagged as a code violation and left in operation.
 - 2. If the water heater does not operate properly, it shall be turned off and tagged as a hazardous condition. See [TURN 2.7](#) Warning Tag.
- 5.3.2 Water heaters in mobile homes and manufactured housing must be listed or approved for such use.
- 5.3.3 Gas water heaters in a manufactured home shall be installed such that its combustion and ventilation air are obtained from the outside by either:
 - 1. Sealed combustion water heater, or
 - 2. Installed in an enclosure that separates the appliance's combustion system and venting system from the interior environment of the manufactured home.

UNCONTROLLED IF PRINTED

There shall not be any door, removable access panel, or other opening into the enclosure from inside the manufactured home. If an opening is found, issue Warning Tag. See [TURN 2.7](#) Warning Tag.

5.4 Visual Inspection

5.4.1 Make sure the water heater has adequate combustion and ventilation air for proper operation. See [TURN 2.5](#) Combustion and Ventilation Air and Venting Requirements.

5.4.2 Check that no combustible materials are stored near the water heater.

5.4.3 All water heaters must have a sediment trap before the control valve and a shut off valve within 6 feet and in the same room.

1. Existing appliances without a sediment trap or shut off valve may be lit, however a "**Warning**" tag for a code violation should be issued.
2. Original water heaters in HUD approved manufactured homes will not have drip legs but should have shut off valve.
3. Replacement water heaters in manufactured homes shall comply with this requirement.
4. Ensure the water heater is listed for natural gas.

5.4.4 Inspect the water heater vent system: See [TURN 2.5](#).

1. Draft diverter is securely in place.
2. Single wall pipe is used only from the draft diverter to the chimney or flue and shall not pass through any attic, inside wall, concealed space or floor.
3. Single or double wall vent pipe joints are screwed or locked in place. High temperature flue vent tape can be used to secure the vent pipe joint.
4. Horizontal sections have a minimum of ¼" per foot uphill pitch and are supported every 6 feet.
5. Inspect for corrosion or discoloration at joints. (Indication of condensation)
6. Check for vent height, termination, and vent cap.
7. Check for plastic vent. See [TURN 2.5](#) for recall information.

5.4.5 Make sure the water heater has a temperature and pressure relief valve (T&P valve).

1. The T&P valve discharge pipe must be approved for hot water distribution, terminate within 6 inches of the floor, and have no threads on outlet end.
2. The size of the discharge pipe cannot be downsized nor can a valve be installed between the T&P and the end of the discharge pipe.
3. T&P valve relief discharge piping on water heaters in manufactured housing may be plastic pipe.

5.5 Operational Check for Conventional Water Heater

5.5.1 First, verify that the water is turned on. If water does not come out of the hot- and cold-water faucet, do not light the water heater.

5.5.2 Remove outer and inner combustion doors.

5.5.3 Inspect condition of the burner assembly to ensure it is suitable for operation.

UNCONTROLLED IF PRINTED

5.5.4 Check the appliance safety in the control valve for proper operation. See [Section 10.0](#).

5.5.5 Light the pilot.

Position your head a safe distance away to prevent injury from possible flame rollout.

5.5.6 Turn the control valve to the "on" position.

5.5.7 Light the pilot and turn the control valve to the "on" position.

5.5.8 Verify that the pilot ignites the main burner completely. Check for proper flame characteristics. See [Section 9.0](#).

5.5.9 Turn the thermostat down to verify that the main burner shuts off, install inner and outer combustion doors.

5.5.10 No water heater shall be left in operation without both doors.

5.5.11 Then turn the thermostat back up to allow main burner to ignite.

5.5.12 While the main burner is operating, check for spillage at the draft hood.

1. It may take up to 5 minutes for the vent to warm up before the vent will operate properly.
2. Verify that the products of combustion are being vented outside through the use of such methods as: the hand, smoke from an extinguished match, etc.
3. If the water heater does not vent properly, the water heater shall be turned off and a "**Warning**" tag issued.

5.5.13 After the operational check is completed, return thermostat to the normal temperature setting.

5.5.14 Make sure that the Energy Cutoff (ECO) wires are not bypassed.

5.6 Operational Check for High Efficiency Water Heater

5.6.1 Water heaters with sealed combustion chambers (power vent) shall be checked for operation by turning the thermostat up to allow the water heater to operate.

5.6.2 Then by turning the thermostat back down to verify the water heater responds to the thermostat by shutting off.

5.7 Operational Check for Tankless Water Heater

5.7.1 Water heaters shall be checked for operation by turning on the hot water faucet to allow the water heater to operate.

5.7.2 Then by turning the hot water faucet off to verify the water heater responds by shutting off.

5.7.3 Verify unit is venting properly.

5.8 Flammable Vapor Ignition Resistant (FVIR) Water Heaters

5.8.1 The Consumer Products and Safety Commission found thousands of fires, injuries and deaths were related to water heaters installed in areas where flammable liquids are stored or used.

UNCONTROLLED IF PRINTED

1. All conventional residential 50-gallon and smaller water heaters manufactured after *July 1, 2003* had to comply with ANSI FVIR standards.
 2. Power vented residential water heaters, 50 gallons and smaller, manufactured after *July 1, 2006* had to comply with FVIR standards.
 3. All remaining residential water heaters manufactured after *July 1, 2007* had to comply.
- 5.8.2 A FVIR water heater should not ignite flammable vapors outside the water heater created because of improper storage or handling/spillage of gasoline on the floor near the water heater.
- 5.8.3 A FVIR water heater has the following components:
1. A device to prevent ignited vapors from passing out of the combustion chamber.
 2. A one-way intake system to control the movement of makeup air into the combustion chamber.
 3. An inner door and burner assembly to create a sealed junction with the combustion chamber, preventing combustion air and flammable vapors from entering the chamber through the front of the water heater.
 4. The pilot thermocouple used in FVIR water heaters includes a one-shot temperature switch that opens the thermocouple circuit if the water heater is not receiving adequate combustion air due to flammable vapors or insufficient room size. See [TURN 2.5](#).
- 5.8.4 If the water heater is in compliance with the FVIR standards, it does not have to be raised 18 inches in garages or similar locations, unless required by the manufacturer or local code authorities. See Figure 1.



Figure 1: FVIR-Compliant

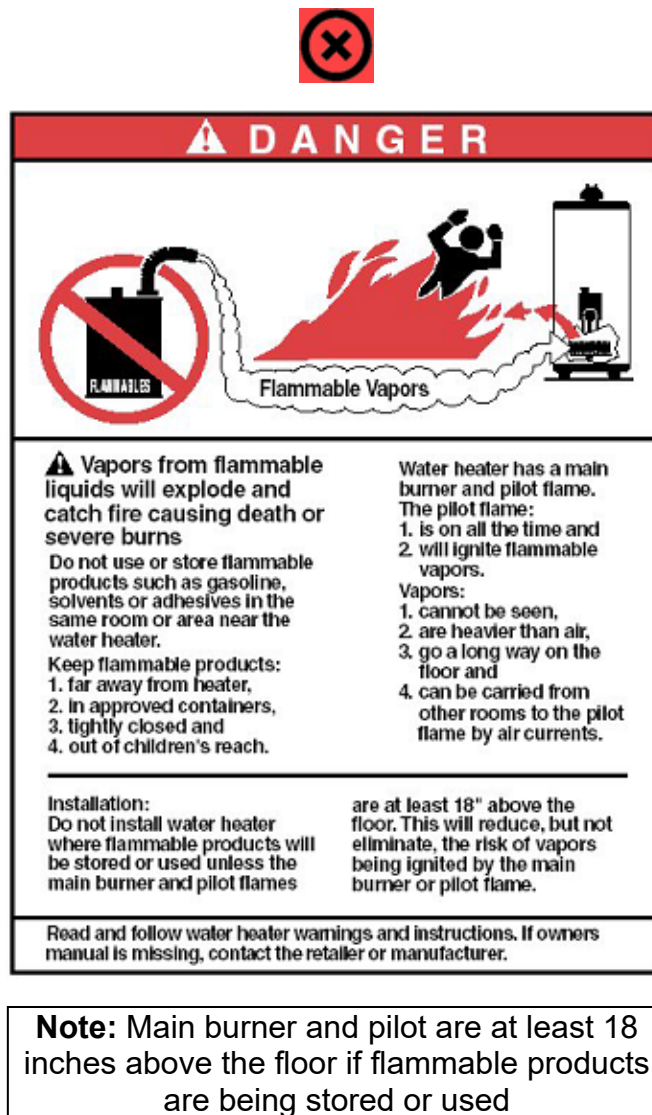

Figure 2: Non-Compliant Water Heater

6.0 Lighting Appliances: Furnaces

6.1 General

- 6.1.1 This section outlines the procedure for inspection and operation of an existing furnace after the fuel lines have been purged of air.
- 6.1.2 All new or repaired appliances shall be checked for proper installation, however, the installing contractor (or designee) shall light the appliance.

6.2 Prohibited Installations

- 6.2.1 Furnaces in residential garages and in adjacent spaces open to the garage shall be installed so that all burners and ignition devices are at least 18 inches above the floor unless listed as Flammable Vapor Ignition Resistant.
- 6.2.2 New or replaced furnace shall not be installed in a bedroom or bathroom unless the bedroom or bathroom has the required volume of combustion and ventilation air. See [TURN 2.5](#).
- 6.2.3 Exceptions:

1. Direct vent, (sealed combustion chamber), furnace that obtains outside combustion air and discharges flue gases to the outdoors
2. A furnace that is installed in a closet equipped with a weather-stripped door with a self-closing device, and all combustion air is obtained from the outdoors.

6.2.4 Replacement furnaces in mobile homes and manufactured housing must be listed or approved and certified for such use.

6.2.5 Unvented natural gas heaters shall not be used as the sole source of heat and shall not be installed in bedrooms or bathrooms unless approved and certified for such use. See [Section 8.0](#) Vent Free Appliances.

6.3 Visual Inspection

6.3.1 Make sure the furnace has adequate combustion, ventilation and circulation air for proper operation.

1. High efficiency furnaces (sealed combustion chamber) may be installed so the combustion/ventilation air is taken from inside the structure; however, it must meet the minimum required volume. See [TURN 2.5](#).
2. Furnaces in manufactured homes shall be installed such that their combustion system and venting system has a complete separation from the interior environment of the manufactured home.

6.3.2 Check that no combustible materials are stored near the furnace.

6.3.3 All new or replaced furnaces shall have a sediment trap before the control valve and a shut off valve within 6 feet and in same room.

1. Original furnaces in HUD manufactured homes may not have a sediment trap upstream of the furnace, but should have a shut off valve.
2. Existing appliances without a sediment trap and or a shut off valve may be lit. However, a "**Warning**" tag for code violation shall be issued.

6.3.4 Inspect the furnace vent system. See [TURN 2.5](#).

6.4 Operational Check

6.4.1 Inspect air shutters, burners and runner tubes for blockage and corrosion, and clean if necessary. Look for obvious cracks, openings, or excessive corrosion in the heat exchanger.

6.4.2 Turn the thermostat up as high as possible, if not previously done, and check the safety in the control valve for proper operation. See [Section 10.0](#) Appliance Safety.

6.4.3 Verify that the appliance valve is in the "off" position.

Use the electric switch for the furnace control valve if available to control the ignition.

6.4.4 Light the pilot.

Position your head a safe distance away to prevent injury from possible flame rollout.

- 6.4.5 Turn the furnace control valve to the "on" position.
 - 6.4.6 Turn on the electric switch if used. Observe that the pilot ignites the runner tube, and that the runner tube ignites the burners end to end.
 - 6.4.7 Check for proper flame characteristics. Adjust air shutter if necessary to obtain proper flame characteristics. See [Section 9.0](#).
 - 6.4.8 While the blower is still off, continue to observe the flame characteristics from each burner.
 - 6.4.9 While the main burner is operating, check for spillage at the draft hood. It may take up to 5 minutes for the vent to warm up before the vent will operate properly.
 - 6.4.10 Verify that the products of combustion are being vented outside by using methods such as the hand, smoke from an extinguished match, etc. If the furnace is not venting properly, shut off the furnace and issue a **"Warning"** tag.
 - 6.4.11 Continue to observe the flames while the furnace is heating up, and with the blower operating. Observe the burners for distorted flames that may indicate an air disturbance in the heat exchanger.
 - 6.4.12 Check the burners a second time with the blower operating, to verify the blower does not distort the flames as pressure increases through the heat exchanger from blower operation.
 - 6.4.13 After the operational check is complete, adjust thermostat as needed to ensure furnace cycles.
 - 6.4.14 Re-install the furnace doors and return the thermostat to a normal setting for the season. Furnace doors shall always be in place when furnace is operating.
- 6.5 High Efficiency Furnaces
- 6.5.1 Furnaces with sealed combustion chambers, such as a 95+ efficient furnace, must be checked for proper operation.
 - 1. Turn the thermostat up to allow the furnace to operate with the blower on.
 - 2. Then turn the thermostat back down to verify the furnace responds to the thermostat by shutting off.

If the high efficiency furnace combustion air is not obtained from the outdoors, then the minimum room size for total BTU input is applicable. See [TURN 2.5](#) Combustion and Ventilation Air and Venting Requirements.

7.0 Boilers

7.1 General

UNCONTROLLED IF PRINTED

- 7.1.1 This section outlines the procedures for inspecting and lighting of an existing boiler after fuel lines have been purged of air.
- 7.1.2 All new or repaired appliances shall be checked for proper installation however, the installing contractor (or designee) shall light the appliance.

7.2 Prohibited Installations

- 7.2.1 Boiler in residential garages and in adjacent spaces open to the garage shall be installed so all burners and ignition devices are at least 18 inches above the floor, unless listed as FVIR. See [Subsection 5.8](#) for explanation of FVIR.
- 7.2.2 New or replaced boiler shall not be installed in a bedroom or bathroom unless the bedroom or bathroom has the required volume of combustion and ventilation. See [TURN 2.5](#) Combustion and Ventilation Air and Venting Requirements.
- 7.2.3 Exceptions
 1. Direct vent (sealed combustion chamber) boiler that obtains outside combustion air and discharges flue gas to the outdoors.
 2. A boiler that is installed in a closet equipped with a weather-stripped door with a self-closing device and all combustion air is obtained from the outdoors.

7.3 Visual Inspection

- 7.3.1 Make sure the boiler has adequate combustion, ventilation and circulation air for proper operation.
 1. High efficiency boiler (sealed combustion chamber) may be installed so the combustion/ventilation air is taken from inside the structure, however, it must meet the minimum required volume. See [TURN 2.5](#) Combustion and Ventilation Air and Venting Requirements.
 2. Boiler in manufactured homes shall be installed such that their combustion system and venting system has a complete separation from the interior environment of the manufactured home.
- 7.3.2 Check that no combustible materials are stored near the boiler.
- 7.3.3 All new or replaced boilers shall have a sediment trap before the control valve and a shut off valve is within 6 feet and in the same room.
 1. Original boiler in HUD manufactured homes may not have a sediment trap upstream of the boiler, but should have a shut off valve.
 2. Existing appliances without a sediment trap and or a shut-off valve may be lit. However, a "**Warning**" tag for code violation shall be issued.
- 7.3.4 Inspect the boiler vent system. See [TURN 2.5](#) Combustion and Ventilation Air and Venting Requirements.

7.4 Operational Check

- 7.4.1 Inspect air shutters, burners and runner tubes for blockage and corrosion, clean if necessary. Look for obvious leaks or excessive corrosion.
- 7.4.2 Turn the thermostat up as high as possible, if not previously done, and check the safety in the control valve for proper operation. See [Section 9.0](#) Appliance Safety.

UNCONTROLLED IF PRINTED

7.4.3 Verify that the appliance valve is in the "off" position.

Use the electric switch for boiler control valve if available to control the ignition.

7.4.4 Light the pilot

Position your head a safe distance away to prevent injury from possible flame rollout.

7.4.5 Turn the boiler control valve to the "on" position.

7.4.6 Turn on the electric switch, if used. Observe that the pilot ignites the runner tube and that the runner tube ignites the burner end to end.

7.4.7 Check for proper flame characteristics. Adjust air shutter if necessary to obtain proper flame characteristics. See [Section 9.0](#) Flame Characteristics.

8.0 Vent-Free Appliances

8.1 General

8.1.1 Vent-free gas appliances must be approved and installed as supplemental heat in accordance with manufacturer recommendations, the National Fuel Gas Code, and local codes if they exist.

8.2 Supplemental Heat Source Only

8.2.1 A residence must have a primary heating source before a vent-free gas appliance can be installed to provide a source of supplementary heat.

8.2.2 A primary heating source shall be permanently installed and reasonably sized for the area being heated such as a:

1. Furnace,
2. Heat pump,
3. Electric baseboard, or
4. Another type of heat source.

8.2.3 If a vent-free gas appliance is being used as the primary heating source in a residence, it shall be considered a hazardous condition. Isolate the appliance by shutting off the appliance valve or the appliance control valve and issue a **"Warning"** tag as a hazardous condition.

8.3 Installation Limits

8.3.1 The following table outlines the allowed limits for installation.

Table 1: Limits for Vent-Free Appliances

	Bathroom	Bedroom	Other	Manufactured Homes
--	----------	---------	-------	--------------------

UNCONTROLLED IF PRINTED

Minimum Room Volume	50 cubic feet per 1,000 Btu/Hr appliance	50 cubic feet per 1,000 Btu/Hr appliance	50 cubic feet per 1,000 Btu/Hr appliance	Not allowed unless marked approved for use in manufactured homes.
Maximum Appliance Input Rating	6000 Btu/Hr	10,000 Btu/Hr	40,000 Btu/Hr	Not allowed unless marked approved for use in manufactured homes.

- 8.3.2 Other locations include living rooms, family rooms, kitchens, etc. Adjoining rooms shall be considered part of the room volume if the opening between the rooms cannot be closed with a door.
- 8.3.3 If these requirements are not met, isolate the appliance by shutting off the appliance valve, appliance control valve, or the meter valve and issue a **"Warning"** tag as a hazardous condition.

9.0 Flame Characteristics

- 9.1 The flame characteristics should be burning hard, sharp, and blue in color.
- 9.2 Yellow flames may indicate insufficient combustion air and may require the adjustment of the air shutter.

Orange streaking or tipping in the flame should not be confused with yellow streaking or tipping. Dust or moisture in the air can cause orange streaking in the flame. Yellow flames indicate insufficient combustion air.

- 9.3 If the flame is lifting off of the burner or extending beyond the heating plate, there may be excessive gas pressure or combustion air. This may be corrected by adjusting gas pressure at the appliance regulator or by adjusting the burner orifice.
- 9.4 Flash back or flames rolling out of the front of a furnace when the burner is ignited may be caused by delayed ignition.
- 9.5 Floating flames, flames being pushed down or under burner, or flames rolling out the front of a furnace may indicate a plugged cell in the heat exchanger.
- 9.6 If proper flame characteristics cannot be obtained through the provided procedures, issue a **"Warning"** tag and isolate the appliance. See [TURN 2.7](#) Warning Tag for Hazardous Conditions.

10.0 Appliance Safety

10.1 General

- 10.1.1 This guideline outlines the procedure for checking the appliance safety. The safety is associated with the control valve on an appliance and is designed to prevent the flow of gas to the burner when the pilot goes out.

10.2 Appliance Safety Check

- 10.2.1 Turn the control valve to the "off" position and manually shut off any standing pilots.
- 10.2.2 If appliance has been operating, wait 5 minutes for the thermocouple to cool down.
- 10.2.3 Turn the thermostat up as high as possible.

UNCONTROLLED IF PRINTED

- 10.2.4 Position your head close enough to hear gas flow and turn the control valve to the full "on" position.
- 10.2.5 Listen for gas flowing through the orifice to the main burners or use a Combustible Gas Indicator (CGI) to verify whether or not there is gas present.
1. If background noise is present or if the gas field personnel have a hearing impairment, use a CGI or an electronic leak detector to verify the safety is working properly.
 2. If you hear gas flowing or have a CGI reading, then the safety has failed. Turn the control valve to the "off" position.
 3. If you do not hear gas flowing, then the safety is working. You may proceed with lighting procedures for the appliance.
- 10.2.6 If the safety does not operate properly, turn off the appliance and issue a "**Warning**" tag for a hazardous condition.
- 10.2.7 The appliance shall be isolated and not be operated until the control valve has been replaced.
- 10.2.8 No appliance shall be left in operation with a known defective safety.

End of Instructions.

Operator Qualification (OQ) Required?

YES

A001: Service Reconnect

Appendices

NONE.

Attachments

NONE.

Compliance Requirements

ANSI Flammable Vapor Ignition Resistant (FVIR) Standard

HUD Title 24, 24 CFR § 3280.609

HUD Title 24, 24 CFR § 3280.707

NFPA 54 National Fuel Gas Code.

Reference Documents

[TURN 2.5 Turn-On Turn-Off: Combustion and Ventilation Air and Venting Requirements](#)

[TURN 2.7 Turn-On Turn-Off: Warning Tag](#)

[TURN 2.9 Turn-On Turn-Off: Brass Appliance Connectors](#)

Document Rescission

TURN 2.4 Turn-On Turn-Off: Lighting Appliances and Appliance Safety, October 1, 2021

UNCONTROLLED IF PRINTED

Revision Notes

Location of Changes	Summary of Changes
Paragraph 4.3.4	Updated Reference link to Section 9.0 Flame Characteristics.
Paragraph 4.4.2 Item 2a.	Updated Reference link to Section 10.0 Appliance Safety
Paragraph 4.4.3	Updated Reference link to Section 9.0 Flame Characteristics.
Paragraph 5.5.4	Updated Reference link to Section 10.0 Appliance Safety
Paragraph 5.5.8	Updated Reference link to Section 9.0 Flame Characteristics.
Paragraph 6.2.5	Updated Reference link to Section 8.0 Vent Free Appliance
Paragraph 6.4.2	Updated Reference link to Section 10.0 Appliance Safety
Paragraph 6.4.7	Updated Reference link to Section 9.0 Flame Characteristics
Inserted New Section – Section 7.0 Residential Boilers	Procedures for inspecting and lighting a residential boiler.

TURN 2.5 Combustion and Ventilation Air and Venting Requirements

1.0 Purpose

This document specifies combustion and ventilation air requirements for gas appliances and venting requirements.

2.0 Scope

This document addresses the following:

[3.0 Target Audience](#)

[4.0 Combustion and Ventilation Air](#)

[5.0 Venting](#)

3.0 Target Audience

- Gas Field Personnel
- Gas Supervisors
- Meter Changers
- Meter Specialists

4.0 Combustion and Ventilation Air

4.1 General

Insufficient air quantities can lead to incomplete combustion, which can endanger our customers.

4.1.1 This procedure outlines the combustion and ventilation air requirements for gas appliances.

4.1.2 Adequate combustion, ventilation and circulation air for the operation of all gas appliances should be verified.

4.2 Minimum Required Volume

4.2.1 See [Table 1](#) for the minimum room size for total BTU input.

4.2.2 When the room size does not meet these minimums, air openings are required from other parts of the structure or outdoors to provide adequate combustion and ventilation air.

4.2.3 These square foot calculations are based on rooms with 8-foot ceilings.

Table 1: Minimum Room Size for Total BTU Input

BTU Input	Room Size Sq. Ft.	BTU Input	Room Size Sq. Ft.
5,000	32	100,000	625
10,000	63	120,000	750
20,000	125	140,000	875
40,000	250	160,000	1,000
60,000	375	180,000	1,125

UNCONTROLLED IF PRINTED

80,000	500	200,000	1,250
--------	-----	---------	-------

4.3 Circulating Air

- 4.3.1 The return air to a furnace shall be ducted from the furnace casing to another room whenever the circulating air is ducted to another room.
- 4.3.2 Any louver or grill that is installed in the return air duct and located in the room containing the furnace shall be sealed closed. If louver or grill is not sealed, isolate appliance by shutting off the appliance valve or the appliance control valve and issue a "**Warning**" tag as a hazardous condition.

4.4 Requirements for Combustion and Ventilation Air

4.4.1 Indoor Combustion Air

1. When air is obtained from inside the building there shall be two openings:
 - 1 a. One commencing within 12 inches of the ceiling, and
 - 1 b. One opening within 12 inches of the floor.
2. Each opening must be at least 100 square inches of net free area and larger if restricted with louvers or grills.

4.4.2 Outdoor Combustion Air

1. When air is obtained from the outdoors, there are two available options.
 - 1 a. *Option 1: Two permanent openings.* One opening commences within 12 inches of the ceiling. One commences within 12 inches of the floor.
 - 1 b. *Option 2: One larger permanent opening.* The opening commences within 12 inches of the ceiling.
2. The openings shall communicate directly with the outdoors, or through a vertical or horizontal duct to the outdoors or spaces that freely communicate with the outdoors (e.g., a ventilated crawl space or attic).
3. See [Figure 1](#) for minimum sizes of the openings.

4.4.3 If the requirements for combustion and ventilation air do not meet NFPA code as outlined in this guideline, but the appliance operates properly, a "**Warning**" tag shall be issued as a code violation.

4.4.4 If the requirements for combustion and ventilation air do not meet NFPA code as outlined in this section and the appliance does not operate properly, isolate appliance by shutting off the appliance valve or the appliance control valve and issue a "**Warning**" tag as a hazardous condition.

4.5 Louvers and Grills

4.5.1 When determining the opening size of a louver or grill, consider the restriction that is caused by the metal grid or wooden slats.

4.5.2 This restriction will reduce the free area and ability of air to flow through the louver or grill. When calculating the permanent opening to obtain air from either indoors or outdoors, the opening must be increased in size to compensate for this restriction.

1. Wood louvers have 25% free area.
2. Metal louvers or grills have 75% free area.
3. The free area of a metal grill may be stamped on the backside.

UNCONTROLLED IF PRINTED

4.6 Openings for Combustion and Ventilation Air

4.6.1 See [Figure 1](#) and [Table 2](#) to identify the size and number of air openings required for equipment located in a space that does not meet the "minimum required volume" for combustion and ventilation air.

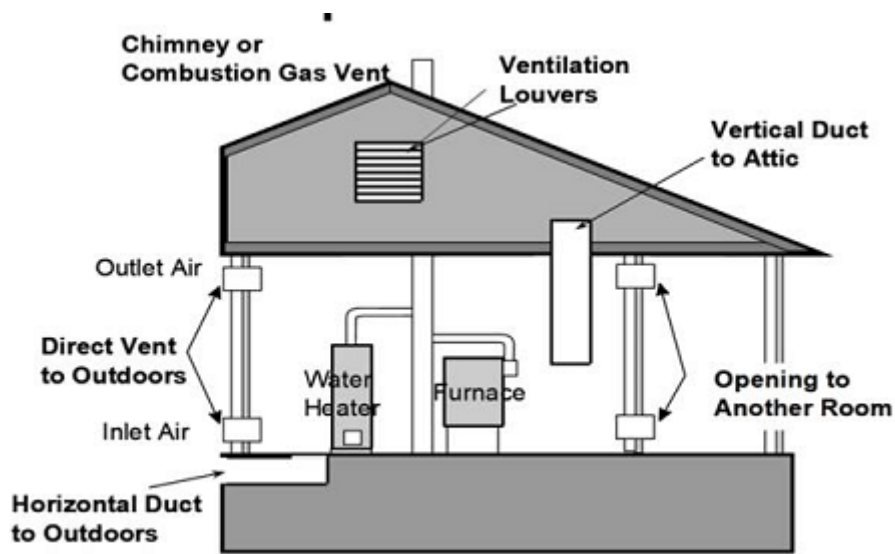

Figure 1: Air Openings for Combustion and Ventilation Air

Table 2: Minimum Size Requirements for Air Openings

Air Opening	Minimum Size Required
Direct Vent to Outdoors (single opening)	1 sq in per 4,000 Btu
Direct Vent to Outdoors (two openings)	1 sq in per 2,000 Btu each
Vertical Duct to Outdoors or Attic	1 sq in per 4,000 Btu
Horizontal Duct to Outdoors	1 sq in per 2,000 Btu each
Opening to Another Room	1 sq in per 1,000 Btu each

5.0 Venting

5.1 General

- 5.1.1 This procedure outlines the venting requirements for gas appliances.
- 5.1.2 Qualified individuals performing routine work such as connects, meter installs, meter changes, leak investigations, etc. shall be aware of these requirements.

5.2 Definitions

- 5.2.1 A *Category 1 appliance* operates with a negative draft vent and a flue gas temperature high enough to avoid formation of condensation in the vent pipe. Appliances that are listed as Category 1 are normally referred to as "conventional appliances" and require metal venting materials.
- 5.2.2 A *Category 4 appliance* operates with a power vent that has a positive pressure and a flue gas temperature cool enough to cause the formation of condensation in the vent pipe. Appliances that are listed as Category 4 are normally referred to as "high efficiency appliances" and require plastic venting materials.

5.3 Venting Code

UNCONTROLLED IF PRINTED

- 5.3.1 Horizontal vent pipe should have a minimum of ¼" rise per foot.
- 5.3.2 No appliance designed to be connected to a vent shall be left in operation without a vent, an improper vent or a deteriorated vent system.
- 5.3.3 When two or more appliances are connected to a common vent or chimney flue, the smaller vent connector shall enter at the highest level.
- 5.3.4 Gas utilization equipment shall not be connected to a chimney flue serving a separate appliance designed to burn solid fuel.

Exception: A vent connector shall not be connected to a chimney flue serving a fireplace unless the fireplace flue opening is permanently sealed.

- 5.3.5 Single wall metal pipe shall not be used as a gas flue in dwellings and residential occupancies because it requires a large clearance to combustibles, is difficult to support and can have a short life due to condensation and exposure to elements.
- 5.3.6 Single wall pipe may only be used as a vent connector from the appliance to the chimney or Type B gas vent.
- 5.3.7 Improper installation or use of single wall pipe is a code violation unless it is passing through unprotected combustible material in which case it is a hazardous condition. See [TURN 2.7](#) Warning Tag.
- 5.3.8 Single wall vent pipe shall not be used outdoors, shall not originate in any unoccupied attic or concealed space and shall not pass through any attic, inside wall, concealed space, or floor.
- 5.3.9 A Category 4 appliance vent shall have a dedicated vent and shall not share a vent with a Category 1 appliance.
- 5.3.10 Gas dryers shall be exhausted (ducted) to the outdoors.
 - 1. Dryer exhaust shall **not** be connected into any gas vent, chimney wall, ceiling, attic, crawl space, or a concealed space of a building.
 - 2. Exhaust ducts shall be a rigid or UL listed flexible metal vent material. **Do not** use plastic or foil type vent material.
 - 2 a. Rigid metal duct material is required when vent passes through walls, ceiling or floors. The space around the duct shall be sealed with a non-combustible material.
 - 2 b. Flexible metal vent can be used as a transition from the dryer to the rigid metal duct.
 - 2 c. Flexible metal ducts are acceptable only if they are accessible for cleaning.
 - 2 d. Flexible metal vents must be fully extended and supported in the final dryer location. Remove excess to avoid sagging and kinking that could reduce airflow and poor performance.
 - 2 e. Flexible metal vents are not to be installed in or through enclosed walls, ceilings or floors.

UNCONTROLLED IF PRINTED

3. Exhaust ducts shall **not** be assembled with screws or other fastening means that extend into the duct. External clamps or tape, such as duct tape, shall be used to make connections.
4. Exhausting duct shall be dedicated for the dryer only.

5.4 Recall of High Temperature Plastic Vent (HTPV) Pipe

5.4.1 HTPV (high temperature plastic vent) pipe used in certain installations has been recalled because the HTPV pipe could crack or separate at the joints and leak flue products, including carbon monoxide, into the home.

5.4.2 This recall includes certain furnace and boiler vents installed after September 1987. Use the following information to identify a recalled plastic vent pipe system and refer to [Figure 2](#).

1. The vent pipes are colored gray or black.
 2. The vent pipes have the names "Plexvent", "Plexvent II", or "Ultravent" stamped on vent pipe or printed on stickers placed on pieces used to connect the vent pipes together.
 3. For furnaces, only HTPV systems that have vent pipes that go through the sidewalls of structures (horizontal systems) are subject to this program.
 4. For boilers, all HTPV systems are subject to this program.
- 5.4.3 If you discover this type of vent pipe, have the customer call the special toll-free number (800) 758-3688, available between 7 A.M. and 6 P.M. CST Monday - Friday, to verify that their HTPV pipe systems are subject to this recall program. Customers with eligible systems will receive a rebate towards a replacement or a new system.



Figure 2: Examples of Recalled Plastic Vent Pipe Systems

End of Instructions.

Operator Qualification (OQ) Required?

NO.

Appendices

UNCONTROLLED IF PRINTED

NONE.

Attachments

NONE.

Compliance Requirements

NFPA 54 National Fuel Gas Code, 2018 Edition

Reference Documents

[TURN 2.7 Turn-On Turn-Off: Warning Tag](#)

Appliance installation instructions (as applicable)

Document Rescission

TURN 2.5 Turn-On Turn-Off: Combustion Ventilation Air and Venting, October 1, 2020

Revision Notes

Location of Changes	Summary of Changes
Paragraph 5.3.1 – Venting Code	"minimum of 1/4" rise per foot
Paragraph 5.3.4 NOTE:	Revised – A vent connector shall not be connected to a chimney flue serving a fireplace unless the fireplace flue opening is permanently sealed.
Paragraph 5.3.5	"gas flue" replaces "gas vent"

TURN 2.6 Corrugated Stainless Steel Tubing - CSST

1.0 Purpose

This document specifies requirements for installation of corrugated stainless steel tubing (CSST) for use in residential, commercial, and industrial services.

2.0 Scope

This document addresses the following:

[3.0 Target Audience](#)

[4.0 General](#)

[5.0 Inside Installation](#)

[6.0 Outside Installation](#)

3.0 Target Audience

- Gas Field Personnel
- Gas Supervisors
- Meter Changers
- Meter Specialists

4.0 General

- 4.1 CSST is **not** intended to be used for mechanical support. It should **not** be connected to the outlet of the gas meter bar.
- 4.2 All fittings and accessories used in the installation of CSST piping systems shall be approved by the manufacturer for use with their system.
- 4.3 The polyethylene jacket should be left on the CSST for the length of penetration through metal, masonry or concrete to provide a sleeve to protect the integrity of the pipe.

5.0 Inside Installation

- 5.1 The tubing should terminate either inside or outside of the foundation wall with a termination fitting. The meter shall be rigidly connected to the termination fitting with 1-inch IPS schedule 40 black iron pipe.
- 5.2 Gas piping shall **not** be used as a grounding conductor or electrode.
- 5.3 For 2 psig systems, CSST regulators must be installed horizontally in the upright position for proper operations of the vent limiter. Regulator without a vent limiter must be vented to the outdoors.
- 5.4 CSST may be directly connected to a fixed appliance such as a water heater or furnace when it terminates with a proper fitting, gas valve, and sediment trap.
 - 5.4.1 CSST shall **not** be used as a flexible appliance connector to a movable appliance such as a stove or dryer. Do not confuse CSST with flexible connectors (Figure 1).



Figure 1: CSST and Flexible Gas Appliance Connector

5.5 CSST shall terminate with a termination fitting at the entrance to the masonry fire box.

6.0 Outside Installation

- 6.1 CSST shall not be installed underground in contact with the earth or concrete unless the CSST is pre-sleeved (typically with black integral polyethylene) and specifically manufactured to be in contact with the earth or concrete.
- 6.1.1 If using CSST underground that is not pre-sleeved, it shall be installed within an external protective sleeve designed to withstand superimposed loads.
- 6.1.2 All sleeve ends shall be sealed liquid tight.
- 6.1.3 The minimum depth for buried gas piping as described in this procedure is 12 inches from the top of grade.
- 6.1.4 The minimum size of the CSST to be buried is $\frac{3}{4}$ inch.
- 6.2 When CSST is installed outdoors, the exposed stainless CSST tubing (where the jacket has been removed) shall be recovered with UV resistant tape as specified by the CSST manufacturer.

End of Instructions.

Operator Qualification (OQ) Required?

YES

A001: Service Reconnect

Appendices

NONE.

Attachments

NONE.

Compliance Requirements

ANSI LC 1-2018/CSA 6.26-2018, Fuel Gas Piping Systems Using Corrugated Stainless Steel Tubing

Reference Documents

NONE.

Document Rescission

UNCONTROLLED IF PRINTED

TURN 2.10 Turn-On Turn-Off: Corrugated Stainless Steel Tubing - CSST, October 1, 2019.

Revision Notes

Location of Changes	Summary of Changes
Not applicable.	This is a new document.

1.0 Purpose

This document specifies the required actions to be taken when encountering code violations or hazardous conditions on customer gas appliances and house piping.

2.0 Scope

This document addresses the following:

[3.0 Target Audience](#)

[4.0 General](#)

[5.0 Inspecting Customer Piping and Appliances](#)

[6.0 Manufactured Housing](#)

[7.0 Isolating an Appliance](#)

[8.0 Code Violations](#)

[9.0 Hazardous Conditions](#)

[10.0 Customer Mailing](#)

[11.0 Records](#)

Appendices:

[Appendix A - Warning Tag \(Stock Code 16-01-263\)](#)

[Appendix B - CSS-Generated Customer Letter](#)

3.0 Target Audience

- Gas Field Personnel
- Gas Supervisors
- Meter Changers
- Meter Specialists

4.0 General

- 4.1 This section describes the actions to be taken when encountering code violations or hazardous conditions on customer gas appliances and house piping.
- 4.2 An inspection of customer gas appliances and house piping is required when the customer chooses to have Ameren Illinois (AIC) re-light the appliances.
- 4.3 A copy of the Warning Tag is in [Appendix A](#).

5.0 Inspecting Customer Piping and Appliances

- 5.1 Gas field personnel or qualified individuals shall look for code violations and/or hazardous conditions in accordance with NFPA 54, HUD Title 24 Code Part 3280 Manufactured Home Construction and Safety Standards, or applicable local codes.
- 5.2 Where such conditions exist and the correction of the condition exceeds the normal scope of repair work performed by AIC gas field personnel, a **"Warning"** tag shall be completed and documented on the order.

- 5.3 Gas field personnel or qualified individuals may encounter situations that require the issuing of a **"Warning"** tag. However, there may be question whether the situation is a Code Violation or Hazardous Condition.
- 5.4 When in doubt about a situation, refer to the examples listed in this part or contact the Gas Supervisor.

6.0 Manufactured Housing

- 6.1 Gas appliances initially installed in a HUD approved manufactured home comply with the HUD Title 24 Code and are not required to comply with NFPA 54 Code.
- 6.2 Any gas appliance installed in manufactured housing, following the initial consumer sale, shall be labeled "Approved for Manufactured Housing" and installed in accordance with NFPA 54 Code.
- 6.3 Gas appliances installed in the living area of the manufactured home will obtain all combustion and dilution air from outdoors.

7.0 Isolating an Appliance

- 7.1 Gas field personnel may isolate a hazardous condition at the:
 - 7.1.1 Appliance control valve, or
 - 7.1.2 Appliance shut off valve, or
 - 7.1.3 Customer convenience valve, or
 - 7.1.4 Meter valve.
- 7.2 If the hazard is isolated at the meter valve, lock, Red Pin the valve, complete the order, and issue a Warning Tag.

8.0 Code Violations

A code violation is an improper installation that may become hazardous if the customer does not take corrective action.

- 8.1 When a code violation is identified, gas field personnel or qualified person shall do the following:
 - 8.1.1 Issue a **"Warning"** tag as a code violation.
 - 8.1.2 Describe the situation to the customer and explain the potential danger.
 - 8.1.3 Advise the customer to contact a qualified HVAC/plumbing contractor to have the code violation corrected.
 - 8.1.4 Complete and sign the **"Warning"** tag.
 - 1. Request that the customer sign the tag. If the customer refuses or is not available to sign the tag, turn the tag into the Gas Supervisor.
 - 8.1.5 Install the **"Warning"** tag on the piping or appliance, or give to the customer (or their representative). The original is retained by Ameren Illinois and filed for future reference.
- 8.2 Examples of Code Violations

- 8.2.1 Deteriorated or damaged fuel line that does not adversely affect appliance operation.
- 8.2.2 No shut off valve ahead of the appliance.
- 8.2.3 No sediment trap or improperly installed sediment trap on a furnace or water heater.
- 8.2.4 Appliance connector passing through any walls, partitions, ceilings or floors.
- 8.2.5 Two or more appliance connectors connected in series.
- 8.2.6 Horizontal vent pipe that is not sloped uphill at least 1/4" per foot.
- 8.2.7 Horizontal vent pipe that is not supported.
- 8.2.8 Single wall vent pipe not securely fastened together at joints with screws.
- 8.2.9 Single wall vent pipe installed outdoors.
- 8.2.10 Single wall vent pipe installed through protected combustible floor, interior wall, exterior wall or attic.
- 8.2.11 Water heater T&P valve without discharge pipe.
- 8.2.12 Water heater T&P valve discharge pipe with threads on end of pipe.
- 8.2.13 Appliance operating properly but is located in an insufficiently sized confined space.
- 8.2.14 When a furnace and/or water heater is located in a bedroom/bathroom, or an appliance has insufficient combustion/ventilation air, an operational inspection shall be performed with all appliances operating, the door closed and any exhaust fans on.
 - 1. If the appliance operates properly, a code violation shall be issued.
 - 2. If the appliance does **not** operate properly, a hazardous condition shall be issued and the appliance turned off.
- 8.2.15 Corrugated Stainless Steel Tubing (CSST) installation issues:
 - 1. CSST passing through furnace cabinet without protection from chafing.
 - 2. CSST passing through masonry wall/foundation without sleeve.
 - 3. CSST connected directly to outlet of meter set.
 - 4. An exposed metal section of tubing outside.
 - 5. Non pre-sleeved CSST installed underground without conduit.
 - 6. Conduit vented inside.
 - 7. Conduit **not** vented outside.
 - 8. CSST connected directly to moveable gas appliance.

9.0 Hazardous Conditions

A hazardous condition is an improper installation or operation of equipment that requires immediate action when encoun-

tered. **All hazardous conditions shall be corrected before the appliance is operated.**

- 9.1 When a hazardous condition is identified, gas field personnel shall do the following:
- 9.1.1 Isolate any hazardous condition found.
 - 9.1.2 Issue a "**Warning**" tag.
 - 9.1.3 Advise the customer that defective piping or appliances which create a hazardous condition shall not be used until the necessary repairs are completed.
 - 9.1.4 Advise the customer to contact a qualified HVAC/plumbing contractor to correct the condition as soon as possible.
 - 9.1.5 Complete and sign the "**Warning**" tag.
 - 1. Request that the customer sign the tag. If the customer refuses or is not available to sign the tag, turn the tag into the Gas Supervisor.
 - 9.1.6 Install the "Warning" tag on the piping or appliance, or give to the customer (or their representative). The original is retained by Ameren Illinois and filed for future reference.
- 9.2 Examples of Hazardous Conditions
- 9.2.1 Gas leak.
 - 9.2.2 A gas line/valve that is not capped or plugged.
 - 9.2.3 Yellow flames that cannot be corrected by adjustment.
 - 9.2.4 Distorted burner flames.
 - 9.2.5 Appliance safety that does not work properly.
 - 9.2.6 An appliance that is too dirty to operate safely.
 - 9.2.7 Gas piping installed through air duct, gas vent, or chimney.
 - 9.2.8 Gas appliance in a garage or in adjacent space that opens to the garage where the burners and ignition devices are less than 18" above the floor.

Exception: Water heater is listed as Flammable Vapor Ignition Resistant. See [TURN 2.4 Section 5.0](#).

- 9.2.9 Missing combustion door (one or more) or broken combustion chamber sight glass.
- 9.2.10 Glass missing from space heater.
- 9.2.11 Cold air return not ducted to the furnace where the circulating air is ducted to another room.
- 9.2.12 Thermostat that does not shut off the appliance.
- 9.2.13 Grills/louvers installed in the cold air return to the furnace in a confined space.

Must be operable so it can be closed during the heating season.

- 9.2.14 Insufficient combustion or ventilation air where the appliance does not operate properly.
- 9.2.15 Deteriorated or damaged fuel line that prevents proper appliance operation.
- 9.2.16 Missing T&P valve on a water heater.
- 9.2.17 Water heater T&P valve discharge capped or plugged.
- 9.2.18 Water heater with a reduced T&P valve or reduced discharge pipe.
- 9.2.19 Flammable liquids stored near gas appliances.
- 9.2.20 Gas dryer not ducted outdoors or vent assembled with screws.
- 9.2.21 Flexible plastic or thin foil vent tubing used to vent gas dryer.
- 9.2.22 Water heater or furnace that does not vent properly.
- 9.2.23 Water heater or furnace control valves that have been under water due to flooding.
- 9.2.24 Vent pipe is smaller than the appliance draft hood outlet or flue collar and does not meet the Vent Downsizing requirement listed in the NFPA 54 Code 13.1.2.
- 9.2.25 Category 1, natural draft vent appliances sharing a common vent with Category 3 or Category 4 appliance.
- 9.2.26 Natural vent system that does not terminate above an overhang.
- 9.2.27 No termination cap on vent.
- 9.2.28 Single wall vent pipe installed through unprotected combustible material, such as floor, wall, ceiling, etc.
- 9.2.29 Vent-free room heater used as the sole source of heat.
- 9.2.30 Plastic gas pipe used inside a structure or outdoors above ground.
- 9.2.31 An appliance installed in but not approved for mobile home or manufactured housing.
- 9.2.32 Furnace or water heater installed in a bedroom or bathroom that is not a direct vent type.
- 9.2.33 Vent-free appliance larger than 10,000 BTU in bedroom or 6,000 BTU in bathroom.
- 9.2.34 When a furnace and/or water heater is located in a bedroom/bathroom, or an appliance has insufficient combustion/ventilation air, an operational inspection shall be performed with all appliances operating, the door closed and any exhaust fans on.
 - 1. If the appliance operates properly, a code violation shall be issued.
 - 2. If the appliance does not operate properly, a hazardous condition shall be issued and the appliance turned off.
- 9.2.35 Commercial range must have a listed connector and restraint if on casters.

9.2.36 Inside regulator not vented properly. If designed with a vent limiter, the limiter must be facing upward.

10.0 Customer Mailing

10.1 If the customer refuses or is not available to sign the "**Warning**" tag, the Gas Supervisor or Ameren Illinois designee will send a letter with a copy of the original "**Warning**" tag to the customer of record addressing the code violation(s) or hazardous condition(s) encountered.

10.2 In these cases, when the hazardous condition is entered on the customer's account, the official letter can be printed from the Ameren Illinois CSS system. The letter is not signed by anyone at the generating location since the letter contains Ameren Illinois Customer Services contact information.

10.3 See [Appendix B](#) for a sample of the CSS-generated customer letter.

11.0 Records

11.1 All "**Warning**" tag originals should be maintained by each Region for a period of 3 years.

11.2 Customer mailings should be filed with the original Warning tag(s) for future reference.

End of Instructions.

Operator Qualification (OQ) Required?

NO.

Appendices

[Appendix A - Warning Tag \(Stock Code 16 01 263\)](#)

[Appendix B - CSS-Generated Customer Letter](#)

Attachments

NONE.

Compliance Requirements

HUD Title 24 Code

National Fuel Gas Code NFPA 54

Local codes (as applicable)

Reference Documents

NONE.

Document Rescission

TURN 2.11 Turn-On Turn-Off: Warning Tag, October 1, 2019.

Revision Notes

Location of Changes	Summary of Changes
Not applicable.	This is a new document.

Appendix A - Warning Tag (Stock Code 16-01-263)

[\(View/download PDF version\)](#)



Form A-2425 Rev. 10/11 16-01-263

Notice Of Code Violation or Hazardous Condition

Name _____ **Date** _____

Address _____ **City** _____ **State** _____ **OAS #** _____

Code Violation – The condition(s) described below identifies a code violation and should be corrected.

<input type="checkbox"/> No shut off valve	<input type="checkbox"/> Water heater T&P valve without proper discharge pipe
<input type="checkbox"/> No sediment trap	<input type="checkbox"/> Appliance flex connector improperly installed
<input type="checkbox"/> Insufficient combustion or ventilation air	<input type="checkbox"/> Single wall vent pipe () Attic () Exterior Wall () Floor () Outdoors
<input type="checkbox"/> Other/Comments _____	

Hazardous Condition – The condition(s) described below is a hazardous condition and must be corrected.

<input type="checkbox"/> Improper venting () Furnace () Water Heater	<input type="checkbox"/> Missing combustion door(s) () Furnace () Water Heater
<input type="checkbox"/> Ventless heater used as primary heat source	<input type="checkbox"/> Appliance in garage without 18' height () Furnace () Water Heater
<input type="checkbox"/> Appliance not approved for manufactured housing	<input type="checkbox"/> Appliance safety failed () Furnace () Water Heater () Other
<input type="checkbox"/> Gas leak (not repaired)	<input type="checkbox"/> Floating flame/heat exchanger problem
<input type="checkbox"/> Other/Comments _____	

Check box if gas meter has been disconnected

Employee Signature _____

Customer Signature _____

Warning

There is a code violation or hazardous condition that could pose a potential danger.

Contact a reputable HVAC dealer or repair person to correct the condition(s) as soon as possible.

Do not operate equipment if hazardous condition is not corrected.

Remove tag after repairs have been made.

<input type="checkbox"/> Ameren Illinois	1.800.755.5000
<input type="checkbox"/> Ameren Missouri	1.800.552.7583



Si necesita ayuda para entender esta nota, por favor use el servicio de traducción contactando al numero de la compania Ameren localizado al lado del encajonado marcado de esta tarjeta.

Appendix B - CSS-Generated Customer Letter



August 15, 2014

CUSTOMER
Address

HAZARDOUS CONDITION: ACTION REQUIRED

Service Address

Account Number

Dear Customer,

Ameren Illinois has identified a code violation or hazardous condition at the service address noted above. Enclosed is a copy of the Notice of Code Violation or Hazardous Condition, which provides more details.

This condition may result in personal injury or death if corrective action is not taken. For your safety, the required repairs should be made immediately. We recommend that you contact a qualified heating and air conditioning contractor or a qualified plumbing contractor to perform this repair work.

If you have any questions concerning this situation, please refer to the enclosed Notice or call us Monday through Friday, 7 a.m. to 7 p.m.

Sincerely,

Customer Service
1.800.755.5000

***** Manage your account at AmerenIllinois.com *****

Ameren Illinois
300 Liberty St
Peoria, IL 61602

CC 5011

TURN 2.8 Changing Meter Valves

1.0 Purpose

This procedure specifies approved methods for changing meter valves while the service line is under pressure.

2.0 Scope

This document addresses the following:

[3.0 Target Audience](#)

[4.0 General](#)

[5.0 Method 1: NO-BLO Changer](#)

[6.0 Method 2: Operating Property Line Valve](#)

[7.0 Method 3: Activating an EFV](#)

[8.0 Method 4: Excavating and Squeezing PE Pipe](#)

[9.0 Method 5: Excavating the Service Tee](#)

[10.0 Method 6: Installing Control Fitting](#)

[11.0 Method 7: "On-The-Fly"](#)

3.0 Target Audience

- Gas Field Personnel
- Gas Supervisors

4.0 General

- 4.1 This procedure identifies seven approved methods for changing meter valves while the service line is under pressure.
- 4.2 The approved methods are:
- 4.2.1 [Method 1](#): Using NO-BLO meter valve changer.
 - 4.2.2 [Method 2](#): Operating property line valve.
 - 4.2.3 [Method 3](#): Activating an excess flow valve (EFV).
 - 4.2.4 [Method 4](#): Excavating and squeeze polyethylene pipe.
 - 4.2.5 [Method 5](#): Excavating the service tee and closing the punch.
 - 4.2.6 [Method 6](#): Installing a control fitting.
 - 4.2.7 [Method 7](#): Changing a meter valve "on-the-fly" under specified pressure conditions.

5.0 Method 1: NO-BLO Changer

- 5.1 The Dresser and Mueller NO-BLO valve changers are limited to a maximum pressure of 60 psig and may be used for ½", ¾", 1", 1 ¼", 1 ½", and 2" meter valves where the port opening is sufficiently sized to allow passage of the plugging unit.

- 5.2 Follow the manufacturer's instructions when using a NO-BLO changer. See [TAPS 2.2](#) Mueller No-Blow Valve Changer or [TAPS 2.1](#) Dresser Meter Valve Changer.

6.0 Method 2: Operating Property Line Valve

- 6.1 Access and turn off the valve.
- 6.1.1 Inspect the job site and eliminate possible sources of ignition.
 - 6.1.2 Make sure doors and windows of the structure near the job site are closed to prevent gas from entering the structure.
 - 6.1.3 Slightly opening the meter valve to allow the gas to bleed out.
 - 6.1.4 Verify the gas has been shut-off.

7.0 Method 3: Activating an EFV

- 7.1 Changing of meter valves where an excess flow valve (EFV) is installed may be performed as outlined:
- 7.1.1 Inspect the job site and eliminate possible sources of ignition.
 - 7.1.2 Make sure doors and windows of the structure near the job site are closed to prevent gas from entering the structure.
 - 7.1.3 Ensure that a fire extinguisher is present where the work is being performed.
 - 7.1.4 Shut off the old valve and remove piping from the outlet of the meter valve.
 - 7.1.5 Install vent piping to point the flow of gas away from the structure.
 - 7.1.6 Open the old valve, for approximately 2 seconds, which should activate the EFV.
 - 7.1.7 Remove the old valve and install the new meter valve.
 - 7.1.8 Close the new valve and install the outlet piping.
- 7.2 Once the EFV has reset, re-establish service in accordance with [TURN 2.1](#) Residential/ Small Commercial Customer.
- 7.3 If the EFV fails to trip, notify Gas Supervisor for follow up investigation and corrective action if required. Use one of the other procedures to shut-off gas.

8.0 Method 4: Excavating and Squeezing PE Pipe

- 8.1 The service head adapter installed with some PE services may prevent the use of a meter valve changer.
- 8.2 In this situation or where this option is desired, the PE service line may be excavated and squeezed off. See [POLY 2.2](#) Squeeze Off.

9.0 Method 5: Excavating the Service Tee

- 9.1 Changing a meter valve may be performed by excavating the service tee and closing the punch on the service tee.
- 9.2 The closed punch should shut off or significantly restrict the flow of gas to allow the meter valve to be changed.

10.0 Method 6: Installing Control Fitting

- 10.1 Install fitting in accordance with procedures in [TAPS 1](#).
- 10.2 Tap and stop fitting in accordance with manufacturer's instructions.

10.3 Verify the gas has been shut-off by slightly opening the meter valve.

11.0 Method 7: "On-The-Fly"

11.1 Changing a meter valve "on-the-fly" may be performed if conditions do not permit other methods (i.e., use of a NO-BLO meter valve changer, use of an EFV, squeezing a polyethylene pipe, operating service tee or installing a control fitting.)

11.2 Changing a meter valve "on-the-fly" is approved only within the pressure limits specified in Table 1 and shall be performed by two gas field personnel.

Table 1: Pressure Limitations

Service Pipe Size	Maximum Pressure (psig)
½"	100
¾"	100
1"	60
1 ¼"	30
1 ½"	20
2"	10

11.3 "On-The-Fly" Changing Procedure

11.3.1 Before changing the meter valve:

1. All safety equipment shall be in place prior to any additional steps being performed.
2. Gas field personnel at the job site shall wear Level 1 PPE as a precaution due to the exposure to gas associated with changing a valve "on the fly". See [WIGE 2.2](#) Personal Protective Equipment.
3. Verify the operating pressure range of the service to ensure the maximum pressure ([Table 1](#)) is not exceeded. Contact Gas Supervisor if there is a question on the operating pressure.
4. Inspect the job site and eliminate possible sources of ignition.
5. A fire extinguisher shall be at the location where work is being performed and, manned by one individual, while another individual changes the meter valve.
6. Make sure doors and windows of the structure near the job site are closed to prevent gas from entering the structure.
7. Have an x-pander plug available where the work is being performed in case the "on-the-fly" change cannot be completed.

11.3.2 Shut off the old valve. Remove piping from the outlet of the meter valve.

11.3.3 Open the old valve for approximately 2 seconds then shut off the valve to determine the volume of blowing gas that will be present and escaping.

11.3.4 Prepare the new meter valve by placing it in the open position with an approximate 3-foot section of pipe attached to the outlet, to ensure the gas is released above the head of the individual performing the work.

11.3.5 Coat the inlet threads on the new meter valve with thread compound.

11.3.6 Remove the old valve. Install the new meter valve.

11.3.7 Close the new valve, remove the section of pipe, and install the outlet piping.

11.3.8 Re-establish service in accordance with [TURN 2.1](#).

End of Instructions.

Operator Qualification (OQ) Required?

YES

1201: Temporary Isolation of Service Lines and Service Discontinuance

1141: Squeeze Off Plastic Pipe

1131: Stopper (Stopp) Pipe

Appendices

NONE.

Attachments

NONE.

Compliance Requirements

NONE.

Reference Documents

[POLY 2.2 Polyethylene Pipe: Squeeze Off](#)

[TAPS 1 Tapping and Stopping: Requirements](#)

[TAPS 2.1 Tapping and Stopping: Dresser Meter Valve Changer](#)

[TAPS 2.2 Tapping and Stopping: Mueller NO-BLO Valve Changer](#)

[TURN 2.1 Turn-On Turn-Off: Residential/Small Commercial Customer](#)

[WIGE 2.2 Working In Gaseous Environment: Personal Protective Equipment](#)

Document Rescission

TURN 2.8 Turn-On Turn-Off: Changing Meter Valves, October 1, 2020.

Revision Notes

Location of Changes	Summary of Changes
Paragraph 11.3.1. Item 2.	WIGE replaces WWBG.
Paragraph 11.3.1 Item 5.	A fire extinguisher shall be at the location where work is being performed and manned by one individual, while another individual changes the meter valve.
Reference Documents	Updated – WIGE 2.2 Working in Gaseous Environment

TURN 2.9 Brass Appliance Connectors

1.0 Purpose

This document addresses safety issues and public awareness regarding uncoated brass appliance connectors, and specifies actions to take if the connectors are found in service.

2.0 Scope

This document addresses the following:

[3.0 Target Audience](#)

[4.0 General](#)

[5.0 Uncoated Brass Connectors Found in Service](#)

Appendices:

[Appendix A - CPSC Safety Alert](#)

3.0 Target Audience

- Gas Field Personnel
- Gas Supervisors
- Meter Changers
- Meter Specialists

4.0 General

- 4.1 Uncoated brass appliance connectors manufactured before 1980 (approximately) have a serious design flaw.
- 4.2 Experience has shown that the end pieces of these connectors may separate from the tubing causing a serious gas leak.
- 4.3 Numerous deaths, injuries and serious fires have resulted from the failure of uncoated brass connectors. It is expected that the failure rate of uncoated brass connectors will accelerate as they become older and subject to additional flexing.
- 4.4 At least annually, the Gas Communication committee will arrange for a customer bill insert explaining the hazards of uncoated brass connectors.

5.0 Uncoated Brass Connectors Found in Service

- 5.1 Gas field personnel shall inspect customer appliances for the presence of uncoated brass connectors each time they enter a customer home or business in the normal course of their work.
- 5.2 Uncoated brass connectors found should be replaced by the gas field personnel with a stainless steel connector supplied by AIC Ameren Illinois (AIC). Gas field personnel should will explain to the customer why the replacement is necessary.
- 5.3 An approved appliance valve should also be supplied and installed with the stainless steel connector if such a valve is not already in place.
- 5.4 If the workload is such that replacement of the uncoated brass connector cannot be accomplished when initially found:

- 5.4.1 Gas field personnel shall note the location and report it to the Gas Supervisor for later follow-up.
- 5.4.2 Gas Supervisor shall schedule the replacement of the uncoated brass connector as soon as possible but no longer than two months after being notified.
- 5.5 If the customer refuses to have the uncoated brass connector replaced, a **"Warning"** tag shall be issued informing the customer the uncoated brass connector may be dangerous and that they refused to have the connector replaced free of charge.
- 5.6 If the existing uncoated brass connector is improperly installed (e.g., passing through a floor, two or more appliance connectors connected in series) then the improper installation must be corrected by the customer.
 - 5.6.1 In such instances, the installation shall be marked as a code violation. A **"Warning"** tag shall be completed, informing the customer that the violation must be corrected and the uncoated brass connector replaced.
- 5.7 Gas field personnel shall properly discard the uncoated brass connector at their local headquarters or other AIC facility.

End of Instructions.

Operator Qualification (OQ) Required?

NO.

Appendices

[Appendix A - CPSC Safety Alert](#)

Attachments

NONE.

Compliance Requirements

NONE.

Reference Documents

[TURN 2.7 Turn-On Turn-Off: Warning Tag](#)

Document Rescission

TURN 2.15 Turn-On Turn-Off: Brass Appliance Connectors, January 1, 2016.

Revision Notes

Location of Changes	Summary of Changes
Not applicable.	This is a new document.

Appendix A - CPSC Safety Alert

[\(View online.\)](#)



CPSC Safety Alert

Certain Older Gas Connectors May Be Dangerous

Gas connectors are corrugated metal tubes used to connect gas appliances in your home to fuel gas supply pipes. Some older brass connectors have come apart, causing fires and explosions resulting in deaths and injuries.

These older brass connectors have a serious flaw in how their tubing was joined to their end pieces. Over time, the end pieces can separate from the tubing, and cause a serious gas leak, explosion, or fire. To our knowledge, these dangerous uncoated brass connectors have not been made for more than 30 years, but many of them are still in use. The older these connectors get, the greater the possibility of failure.

Although not all uncoated connectors have this flaw, it is very difficult to tell which ones do. Therefore, **any uncoated brass connector should be replaced immediately** with either a new plastic-coated brass connector or a new stainless steel connector. Connectors can wear out from too much moving, bending, or corrosion. Connectors should always be replaced whenever the appliance is replaced or moved from its location.

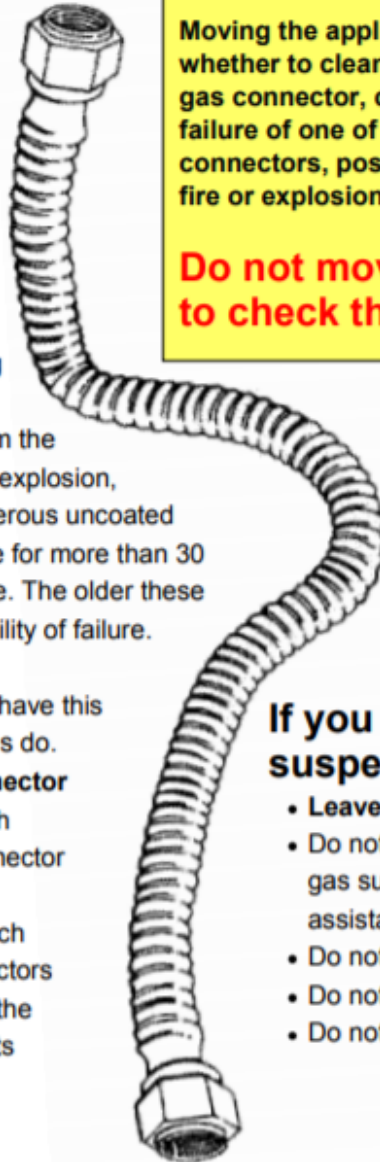

⚠ WARNING

Only a qualified professional should check your connector and replace it if needed. Do not try to do this yourself!

Moving the appliance, even slightly, whether to clean behind it or to inspect its gas connector, can cause the complete failure of one of these older weakened connectors, possibly resulting in a deadly fire or explosion.

Do not move your appliance to check the connector!

If you smell gas and suspect a gas leak:

- Leave the house immediately
- Do not use your phone. Call your gas supplier or dial 911 for assistance from a neighbor's house.
- Do not light a match.
- Do not turn on a light.
- Do not switch on anything electrical.

TURN 2.10 Carbon Monoxide Investigation

1.0 Purpose

This document specifies actions to be performed when assisting the police or fire department with a carbon monoxide (CO) investigation.

2.0 Scope

This document addresses the following:

[3.0 Target Audience](#)

[4.0 General](#)

[5.0 Upon Arrival at the Site](#)

[6.0 CO Investigation](#)

[7.0 CO Checks at Appliances](#)

[8.0 Determining a CO Hazard](#)

[9.0 Potential Effects of Carbon Monoxide Exposure](#)

3.0 Target Audience

- Gas Field Personnel
- Gas Supervisors

4.0 General

- 4.1 AIC gas field personnel may be asked to assist the police or fire department with a CO investigation.
- 4.2 The following outlines actions that should be performed whenever assisting the police or fire department with a CO call.

5.0 Upon Arrival at the Site

- 5.1 Turn on the CGI/CO instrument. Purge in a gas-free environment.
- 5.2 Check for the presence of natural gas on the LEL scale at the entrance of the structure.
- 5.3 Once determined that natural gas is not present, check for the presence of CO at the entrance of the structure.
 - 5.3.1 A CO reading of 100 PPM or higher is considered hazardous. Gas field personnel should not enter the structure until ventilated.
- 5.4 Check for the presence of CO throughout the structure, sampling 6 feet above the floor.
 - 5.4.1 Check all levels of the structure and any attached garage.
 - 5.4.2 CO can enter a structure from a vehicle operating in a garage.
- 5.5 When a CO reading above 15 PPM has been detected by the police, fire department, or AIC gas field personnel, then a CO investigation shall be performed.

Electronic CGI/CO instruments will react to the presence of hydrogen gas which is produced whenever lead acid batteries are being charged. Home owners may use lead acid batteries as a back-up power source for sump pumps.

6.0 CO Investigation

- 6.1 Determine what fuel burning equipment has been operating.
- 6.2 Close all windows and doors. Exhaust fans that may have been operating should be turned on and fuel burning equipment placed into operation.
- 6.3 Check for the presence of CO at heat registers, draft diverters, appliance fire doors, above direct vent and non-vented heaters, above gas fireplace logs, kerosene heaters and near gas stoves.
- 6.4 Check the flame characteristics of each appliance.
- 6.5 Check for adequate combustion and ventilation air.
- 6.6 Conduct a match test at each Category 1 vented appliance.

Appliances should be operating for a minimum of 5 minutes to ensure that the vent system has had ample time to warm up.

- 6.7 Visually check the vents for downward slopes, conflicts such as Category 4 appliance sharing a vent with Category 1 appliance, vent downsizing, outside vent termination height and caps. See Table 1.

Table 1: Category 1 and Category 4 Vent Types and Descriptions

Vent Type	Description
Category 1	Natural draft vent found on conventional appliances
Category 4	Power vent found on high efficiency appliances

7.0 CO Checks at Appliances

- 7.1 If a CO reading is above the maximum allowable CO level, the appliance shall be shut off and a "**Warning Tag**" issued. See [Table 2](#) for maximum allowable CO readings.
 - 7.1.1 *Stove*: CO readings should be taken 12" above each stove top burner and the oven exhaust after the unit has operated through a heating cycle.
 - 7.1.2 *Unvented Space Heater/Gas Log*: CO readings should be taken 24" above the space heater after the burner has operated at the highest setting for 5 minutes.
 - 7.1.3 *Water Heater/Furnace*: A CO reading should be taken above the fire door and above the draft diverter after the unit has operated for 5 minutes to warm the vent system.
 - 7.1.4 *Vented Fireplace*: A CO reading should be taken above the fire box after the unit has operated for 5 minutes to warm the vent/flue system.

7.1.5 **Vent Systems:** The hot combustion gases will damage an electronic CGI/CO instrument. The metallic vent probe and CO filter are required to cool combustion gases and remove impurities.

Table 2: Maximum Allowable CO Reading at a Gas Appliance

Appliance	Maximum CO
Range	45 PPM
Unvented Space Heater/Gas Log	15 PPM
Water Heater/Furnace	0 PPM
Vented Fireplace	0 PPM
Combustion Gases in the Flue	400 PPM

8.0 Determining a CO Hazard

8.1 Always advise the occupant to call a qualified heating and ventilation service (HVAC) contractor to complete a thorough inspection of their system for possible problems.

8.2 Advise the occupants to seek medical attention if they are feeling ill.

Table 3: CO Readings, Exposure and Action Required

CO Reading	Exposure	Action Required
0 to 15 PPM	This is the National Indoor Air Quality Standard for a residential structure.	No action required
16 to 35 PPM	This is an expected level of CO in a residential structure where an unvented appliance such as a stove has been operating for an extended period of time. 15 to 20 PPM may be encountered where occupants have been smoking.	Identify source
36 to 99 PPM	This is a high level of CO in a residential structure.	Conduct a CO
50 PPM	This is the OSHA maximum acceptable level that an average person may be exposed to in the workplace during an 8-hour day.	Identify source Corrective action
100 to 200 PPM	This is a hazardous level of CO in a residential structure. <i>Evacuation of the structure is recommended</i> and the structure must be ventilated by opening doors and windows before a CO Investigation is performed	Ventilate the structure CO Investigation
Greater than 200 PPM	This is an <i>extremely hazardous and life-threatening level of CO and requires an immediate evacuation</i> of the residential structure or areas in a work place where persons are exposed to the danger. Persons feeling ill should contact the Poison Control Center and seek medical attention. Emergency service personnel should be notified to assist with the evacuation and medical treatment.	Evacuate the structure services if occupants are below 100

9.0 Potential Effects of Carbon Monoxide Exposure

9.1 Table 4 shows potential effects and symptoms of CO exposure over time.

Table 4: Potential Effects of CO exposure

PPM	EFFECTS & SYMPTOMS	TIME
-----	--------------------	------

UNCONTROLLED IF PRINTED

200	Slight headache	3 hours
400-600	Headache, discomfort	1-2 hours
1000-2000	Headache, confusion, nausea; may stagger	1.5 hours
2000-2500	Heart palpitation	30 minutes
2500-3500	Unconsciousness	30 minutes
4000	Fatal	30 minutes

9.2 Effects will vary from person to person.

9.3 The health effects of CO depend on the level of CO and length of exposure, as well as each individual's health condition.

9.3.1 Health effects from exposure to CO levels of approximately 1 to 70 PPM are uncertain, but most people will not experience any symptoms. Some heart patients might experience an increase in chest pain.

9.3.2 As CO levels increase and remain above 70 PPM, symptoms may become more noticeable (headache, fatigue, nausea).

9.3.3 As CO levels increase above 150 to 200 PPM, disorientation, unconsciousness, and death are possible.

End of Instructions.

Operator Qualification (OQ) Required?

YES

A001: Service Reconnect

Appendices

NONE.

Attachments

NONE.

Compliance Requirements

NONE.

Reference Documents

OSHA, Carbon Monoxide Fact Sheet ([online here](#))

Document Rescission

TURN 2.10 Turn-On Turn-Off: Carbon Monoxide Investigation, October 1, 2020

Revision Notes

Location of Changes	Summary of Changes
Subsection 5.1	Gas-free environment replaces gas-free atmosphere

UPRT-Uprating

UPRATING

April 1, 2023

UPRT 0 - Table of Contents

UPRT 1 Requirements

Section 1.0 Purpose

Section 2.0 Scope

Section 3.0 Target Audience

Section 4.0 General

Section 5.0 Increasing MAOP Up to 125 psig

Section 6.0 Increasing MAOP Above 125 psig

Section 7.0 Records

Operator Qualifications (OQ)

Attachments

Attachment 1 - MAOP Uprating Plan Form

Compliance Requirements

Reference Documents

Document Rescission

End of Table of Contents.

Document Rescission

UPRT 0 Uprating: Table of Contents, October 1, 2020.

Revision Notes

Location of Changes	Summary of Changes
UPRT 1 Section 5.0 & 6.0	Updated to 125 psig

1.0 Purpose

This document outlines the requirements for raising the maximum allowable operating pressure (MAOP) of gas system while meeting the minimum requirements of 49 CFR 192 Subpart K.

2.0 Scope

This document addresses the following:

[3.0 Target Audience](#)

[4.0 General](#)

[5.0 Increasing MAOP Up to 125 PSIG](#)

[6.0 Increasing MAOP Above 125 PSIG](#)

[7.0 Records](#)

Attachments

[Attachment 1 - MAOP Uprating Plan Form](#) (PDF file)

3.0 Target Audience

- Gas Control
- Gas Engineering
- Gas Supervisors
- Gas Field Personnel
- Gas Tech Engineering (GTE)
- Gas Tech Services (GTS) Supervisors
- Gas Tech Services (GTS) Personnel

4.0 General

- 4.1 Develop project specific uprating procedures to raise the MAOP of a gas system and document them on the MAOP Uprating Plan form. See [Attachment 1](#) MAOP Uprating Plan form.
- 4.2 If remote monitoring capability exists for the affected (uprate) system and adjacent system, then Gas Control shall be involved in the planning, scheduling, and monitoring.
- 4.3 GTS shall:
 - 4.3.1 Establish or verify alarm points for the system being uprated and the adjacent system.
 - 4.3.2 Determine when Gas Control should issue an alarm notice.
 - 4.3.3 After the uprate is complete, verify with Gas Control that operating parameters on the system being monitored have returned to normal or planned operation.
 - 4.3.4 Provide Gas Control with new set points and alarm settings.

5.0 Increasing MAOP Up to **125 PSIG**

- 5.1 Prior to Uprating
 - 5.1.1 Prepare a preliminary map that shows:

UNCONTROLLED IF PRINTED

1. Limits of the proposed area to be updated.
 2. Type, size, age, and location of the facilities to be updated.
 3. Service line locations.
 4. Regulator stations feeding the proposed area.
 5. Isolation valves.
 6. Indication if uprate area and/or adjacent area is remotely monitored by Gas Control.
- 5.1.2 Complete a study to determine that the uprating will not adversely affect the distribution system and include:
1. Verification that all materials for the distribution main and related services are designed for the new MAOP.
 2. Review of leak history and repair records.
 3. Identify the use of compression couplings.
 4. Review service record cards on a low-pressure system to ensure that all low-pressure services have been identified.
 5. Check the service regulator orifice size and capacities.
 6. Verify internal relief capacities and allowable build up.
- 5.1.3 Prepare a written plan for each uprating project and document the plan on the MAOP Uprating Plan form (See [Attachment 1](#)). The plan shall outline:
1. The specific area and services affected.
 2. Steps to be taken to increasing the system pressure.
 3. Maximum allowable operating pressure for the area.
 4. Adequate overpressure protection.
 5. Required communications with Gas Control if area is remotely monitored.
- 5.1.4 A leak survey shall have been conducted on the mains and services within one year prior to the uprating and all potential hazardous leaks shall be repaired before raising the pressure.
- 5.1.5 All steel mains and services shall be under effective cathodic protection. Refer to [CORR 1](#).
- 5.1.6 If the system contains polyethylene (PE) pipe, the PE pipe shall have records demonstrating that it was tested at 1.5 times the proposed MAOP.
1. If there are no test records that substantiate the proposed MAOP, the PE pipe must be tested to 1.5 times the proposed MAOP prior to increasing the operating pressure. See [PTST 1](#).
- 5.1.7 The specifications of the connected equipment shall be reviewed, and any equipment not rated for the new MAOP shall be replaced.
- 5.1.8 Reinforce or anchor all offsets, bends, and dead ends in pipe joined by compression couplings and mechanical joints. Refer to [MAIN 2.3](#) and [REPR 2.1](#).
- 5.1.9 Each service shall have an outside shutoff valve, a regulator, and adequate overpressure protection.

5.2 Polyethylene (PE) Systems

5.2.1 PE systems can be uprated to a new MAOP that does not exceed the MAOP shown in **POLY 2.1 Section 6.0** MAOP Limitations for PE Pipe if:

The review steps as outlined in Paragraph 5.1.1 through 5.1.6 have been successfully completed. AND

The existing PE system has records that demonstrate the system had been tested at 1.5 times the proposed MAOP, at a minimum. OR

If there are no test records that substantiate the proposed Design MAOP, the PE pipe system can be uprated after being retested if:

1. The system is taken out of service and tested to 1.5 times the proposed MAOP, at a minimum, in accordance with **PTST 1**.
2. The system operating pressure shall be established at, or below, the new MAOP before the PE system is placed back in-service.

5.3 Upgrading

5.3.1 A pre-job meeting with all parties shall be held to discuss and approve the procedures in the plan and the various responsibilities. At a minimum the following shall be represented at this meeting:

1. Engineering (Region/GTE);
2. Operations (Region/GTS);
3. Gas Compliance.

5.3.2 The pressure shall be increased gradually at a rate that can be controlled:

1. In equal steps of 10 psig or 25% of the total pressure increase, whichever produces the fewest steps with a minimum of 2 steps.
2. Where the current operating pressure is 12" w.c. or less the same as above in **5.3.2 item 1** with a minimum of two incremental steps and the first step at 2 psig.

5.3.3 A leak survey shall be conducted immediately after each pressure increase step and shall continue until the entire affected area has been surveyed.

5.3.4 All leaks found during the leak survey, shall be classified in accordance with **LEAK 1** and documented within ClickMobile.

1. All hazardous leaks shall be repaired immediately.
2. All non-hazardous leaks shall be reevaluated and documented in ClickMobile after each survey.

6.0 Increasing MAOP Above **125 PSIG**

6.1 Upgrading procedures shall be developed for the upgrade of any gas facilities to or above **125 PSIG** on a case-by-case basis in consultation with:

- 6.1.1 Gas Engineering
- 6.1.2 Gas Tech Engineering
- 6.1.3 Gas Technical Services

- 6.2 Gas Control shall be involved in planning, scheduling, and uprating operation if the affected system or adjacent system is remotely monitored.
- 6.3 These procedures shall be in accordance with 49 CFR Part 192, Subpart K.
- 6.4 A pre-job meeting with all parties shall be held to discuss and approve the procedures in the plan and the various responsibilities. At a minimum the following shall be represented at this meeting:
 - 6.4.1 Engineering (Region/GTE)
 - 6.4.2 Operations (Region/GTS)
 - 6.4.3 Gas Compliance

7.0 Records

- 7.1 The following records associated with the uprating shall be attached to the completed [MAOP Uprating Plan form](#) and retained for the life of the facility:
 - 7.1.1 Leak surveys
 - 7.1.2 Cathodic protection surveys
 - 7.1.3 Regulator orifice changes
 - 7.1.4 Other work performed on the system

End of Instructions.

Operator Qualification (OQ) Required?

YES

- 0061: Inspect or Test Cathodic Protection Bonds
- 0071: Inspect or Test Cathodic Protection Electrical Insulation Devices
- 0301: Manually Opening and Closing Valves
- 0561: Pressure Test - Nonliquid Medium - MAOP Less than 100 psi
- 0571: Pressure Test - Nonliquid Medium - MAOP Greater than or Equal to 100 psi
- 0581: Pressure Test - Liquid Medium
- 0591: Leak Test at Operating Pressure
- 1241: Outside Gas Leak Investigation
- 1261: Walking Gas Leakage Survey
- 1271: Mobile Gas Leakage Survey - Flame Ionization
- 1281: Mobile Gas Leakage Survey - Optical Methane
- 1311: Inspect Pipeline Surface Conditions - Patrol Right of Way or Easement
- 1371: Operate Gas Pipeline - System Control Center Operations
- 1381: Operate Gas Pipeline - Local Facility Remote - Control Operations
- A003: Emergency Response

Appendices

UNCONTROLLED IF PRINTED

NONE.

Attachments

[Attachment 1 - MAOP Uprating Plan Form](#) (PDF file)

Compliance Requirements

49 CFR Part 192 Subpart K - Uprating

Reference Documents

[CORR 1 Corrosion Control: Requirements](#)

[LEAK 1 Leak Management: Requirements](#)

[MAIN 2.3 Main Installation: Pull Out Prevention](#)

[PTST 1 Pressure Testing: Requirements](#)

[REPR 2.1 Repairs: Compression Couplings](#)

Document Rescission

UPRT 1 Uprating: Requirements, October 1, 2020.

Revision Notes

Location of Changes	Summary of Changes
2.0 Scope	5.0 Increasing MAOP Up to 125 psig 6.0 Increasing MAOP Above 125 psig
Section 5.0	Increasing MAOP Up to 125 psig
Subsection 5.2 – Polyethylene (PE) Systems	Revised to clarify the process for increasing the MAOP of a PE system. The MAOP of a PE system can only be increased if the system is test to 1.5 times the proposed new MAOP.
Paragraph 5.3.2, Item 2.	Updated reference to 5.3.2 item 1.
Section 6.0	Increasing MAOP Above 125 psig
Subsection 6.1	Increased MAOP to 125 psig.

VALT-Vault and Pit Inspection

VAULT AND PIT INSPECTION

October 1, 2021

VALT 0 Table of Contents

[VALT 1 Vault and Pit Inspection: Requirements](#)

- Section 1.0 Purpose
- Section 2.0 Scope
- Section 3.0 Target Audience
- Section 4.0 General
- Section 5.0 Inspection
 - Operator Qualification (OQ)
 - Compliance Requirements
 - Reference Documents
 - Document Rescission

[VALT 2.1 Vault and Pit Inspection: Inspecting Vaults and Pits](#)

- Section 1.0 Purpose
- Section 2.0 Scope
- Section 3.0 Target Audience
- Section 4.0 General
- Section 5.0 Vault/Pit Hazard Assessment
- Section 6.0 Working in Gaseous Environment
- Section 7.0 Vault/Pit Inspection
 - Operator Qualification (OQ)
 - Compliance Requirements
 - Reference Documents
 - Document Rescission

End Table of Contents.

Document Rescission

VALT 0 Table of Contents – Vault and Pit Inspection, October 1, 2020

Revision Notes

UNCONTROLLED IF PRINTED

Location of Changes	Summary of Changes
VALT 2.1, Section 6.0	Environment replaces Atmosphere

VAULT AND PIT INSPECTION

October 1, 2020

VALT 1 Requirements

1.0 Purpose

This document describes Ameren Illinois (AIC) requirements for inspection and maintenance of vaults/pits per 49 CFR §192.749.

2.0 Scope

This document addresses the following:

[3.0 Target Audience](#)[4.0 General](#)[5.0 Inspection \(§192.749\)](#)**3.0 Target Audience**

- Gas Field Personnel
- Gas Supervisors.
- Gas Tech Services (GTS) Personnel
- Gas Tech Services (GTS) Supervisors

4.0 General

4.1 A vault is defined as the following:

4.1.1 Subsurface structure housing piping and piping components.

4.1.2 Volumetric internal content of 200 cubic feet or more.

4.1.3 Constructed to be:

1. Sealed in such a manner that would allow gas to accumulate
OR
2. Vented.

4.2 A pit is defined as the following:

4.2.1 Subsurface structure housing piping and piping components.

4.2.2 Volumetric internal content of less than 200 cubic feet.

4.2.3 Constructed to be:

1. Sealed in such a manner that would allow gas to accumulate
OR
2. Vented.

5.0 Inspection (§192.749)

5.1 Vaults housing pressure regulating and pressure limiting equipment shall be inspected at least *once each calendar year* at intervals not exceeding 15 months.

5.1.1 Determine that vault:

1. Is in good physical condition.

- 2. Adequately ventilated.
- 5.1.2 If gas is found in the vault, the equipment in the vault shall be inspected for leaks, and any leaks found must be repaired.
- 5.1.3 The ventilating equipment shall be inspected to determine it is functioning properly.
- 5.1.4 Vault covers shall be inspected to ensure they do not present a hazard to public safety.

End of Instructions.

Operator Qualification (OQ) Required?

YES.

1351: Vault Inspection and Maintenance

Appendices

NONE.

Attachments

NONE.

Compliance Requirements

49 CFR §192.749 Vault Maintenance.

Reference Documents

NONE.

Document Rescission

VALT 1 Vault and Pit Inspection: Requirements, January 1, 2016.

Revision Notes

Location of Changes	Summary of Changes
Not applicable.	This is a new document.

VAULT AND PIT INSPECTION

October 1, 2021

VALT 2.1 Inspecting Vaults and Pits

1.0 Purpose

This document describes Ameren Illinois (AIC) procedures for inspection and maintenance of vaults/pits per 29 CFR §1910.146 and 49 CFR §192.749.

2.0 Scope

This document addresses the following:

[3.0 Target Audience](#)[4.0 General](#)[5.0 Vault/Pit Hazard Assessment](#)[6.0 Working in Gaseous Environment](#)[7.0 Vault/Pit Inspection](#)**3.0 Target Audience**

- Gas Field Personnel
- Gas Supervisors
- Gas Tech Services (GTS) Personnel
- Gas Tech Services (GTS) Supervisors

4.0 General

4.1 Gas field personnel shall:

- 4.1.1 Park on the street or in a safe location. Avoid parking over main valves if they are required for make safe action.
- 4.1.2 Protect themselves from traffic and other hazards while working in or around vaults/pits.
- 4.1.3 Visually inspect all vaults/pits prior to entering, to identify hazards and verify safe for entry.
- 4.1.4 Use a ladder or built-in steps for ingress/egress in vault/pit with depth of 4 feet or more. Do not climb on pipes or regulators.
- 4.1.5 When gas-in-air concentration is equal to or greater than 30% LEL in a vault/pit:
 1. Use only intrinsically safe equipment or tools.
 2. Make all electrical connections and disconnections outside vault/pit.
 3. See [ACIG 2](#) Work Area Protection.
- 4.1.6 Have at least 1 fire extinguisher on the jobsite and upwind from the work area.

4.2 Compressed gas cylinders shall *not* be taken into or stored in a vault/pit.

5.0 Vault/Pit Hazard Assessment

5.1. Environment Testing

- 5.1.1 Test the environment of each vault/pit with gas detection equipment for oxygen deficiency and combustible gas concentration in the following manner:

UNCONTROLLED IF PRINTED

1. Insert a test probe into a hole in the lid, or by lifting the edge of the lid slightly.
 - 1 a. If gas concentration level is equal to or greater than 30% LEL, ventilate the vault/pit.
 2. Continue to check the environment at all levels of the vault/pit:
 - 2 a. Use an extension hose connected to the gas detection equipment.
 - 2 b. Allow instrument readings to stabilize at each level before lowering the probe further.
 - 2 c. Ventilate as needed.
- 5.1.2 If there is a possible source or indication of toxic gasses, such as carbon monoxide or hydrogen sulfide, the environment shall be tested for the specific gas prior to personnel entering the vault/pit.
- 5.1.3 Acceptable environment concentrations for entry without additional Personal Protective Equipment (PPE) required are:
1. Oxygen content between 19.5% and 23.5%.
 2. Gas-in-air concentration is less than 30% LEL.
 3. Carbon monoxide concentration is less than 30 ppm.
 4. For other toxic gas concentrations, contact Safety Specialist for threshold levels if necessary.
- 5.1.4 If acceptable entry conditions are not met, the space shall be ventilated.

Forced air ventilation is generally preferred over exhaust ventilation.

- 5.1.5 Re-test the vault/pit environment to determine if ventilation was adequate to bring concentrations within acceptable entry conditions.

5.2. Space Classification

- 5.2.1 Based upon visual inspection and air testing results, classify each vault/pit as follows:
1. Permit-Required Confined Space (PRCS)
OR
 2. Non-PRCS.
- 5.2.2 A vault/pit shall be considered a PRCS if:
1. Serious safety or health risks *other than natural gas* are present in the space, such as:
 - 1 a. Engulfment.
 - 1 b. Entrapment.
 - 1 c. Unsafe environment.
 - 1 d. Unsafe mechanical items.
 - 1 e. Unsafe electrical items.

UNCONTROLLED IF PRINTED

2. Such risks cannot be eliminated through ventilation or other means.

5.2.3 Entry to PRCS shall comply with 29 CFR §1910.146 including:

1. PPE.
2. Standby personnel.
3. Retrieval/rescue procedures.
4. Signage and barricaded entrance.
5. Training, especially on rescue procedures.

5.2.4 If the vault/pit is classified as PRCS, notify a Safety Supervisor.

5.3. Entry Requirements Based on Air Testing

5.3.1 After ventilation, if air quality is not within the acceptable limits listed below, entry into a vault/pit shall *not be performed* until further measures are taken to improve air quality:

1. Oxygen concentration is not between 19.5% to 23.5%
OR
2. Carbon monoxide concentration is greater than 30 ppm
OR
3. Toxic gas concentrations are above established threshold concentrations.

5.3.2 After ventilation, if the only environment hazard in the vault/pit is natural gas that is less than 30% LEL, then entry procedures shall be per [Paragraph 5.1.3](#).

5.3.3 After ventilation, if the only environment hazard in the vault/pit is natural gas that is equal to or greater than 30% LEL, then entry procedures shall be per [Section 6.0](#).

5.3.4 Continuously monitor the vault/pit environment while personnel are in vault/pit.

6.0 Working in Gaseous Environment

6.1. The following procedures apply where *natural gas is the only environment hazard* in vault/pit.

6.1.1 If gas-in-air concentration is equal to or greater than 30% LEL *but* less than or equal to 60% LEL, entry shall be made with Level 1 PPE (see [WIGE 2.2](#) Personal Protective Equipment) including:

1. Level 1 suit.
2. Goggles.
3. Work gloves.
4. Balaclava.

6.1.2 If gas-in-air concentration is greater than 60% LEL *and* the facility cannot be taken out of service, entry shall be made only with Level 2 PPE (see [WIGE 2.2](#) Personal Protective Equipment) including:

1. Level 2 hood suit.
2. Insulated gloves.
3. Supplied-air respiratory protection.

UNCONTROLLED IF PRINTED

4. Full-body harness and mechanical retrieval device.

7.0 Vault/Pit Inspection

- 7.1 In preparation for inspection, gas field personnel shall:

- 7.1.1 Upon finding gas in vault/pit through monitoring with a CGI, check piping and equipment for leakage.

1. Any leaks found should be classified and repaired per [LEAK 1](#).

- 7.1.2 Inspect piping and equipment for atmospheric corrosion.

- 7.1.3 If the vault/pit is sealed, ensure each opening has a tight-fitting cover without holes through which an explosive mixture might be ignited.

- 7.1.4 Inspect the vault/pit cover and verify that it does not present a hazard to the public.

- 7.1.5 Check the vault/pit structure, concrete, fiber, metal, etc. for deterioration.

- 7.1.6 Report all deficiencies found on the Regulator Station or Valve Inspection forms within ClickMobile.

- 7.2 During inspection:

- 7.2.1 Gas field personnel shall check:

1. Vault/pit has 2 ventilation ducts, each having at least the ventilating effect of a pipe 4 inches in diameter.

2. Ventilation ducts to ensure they are clear.

3. Outside ends of ventilation ducts for suitable weatherproof fitting or vent-head to ensure foreign matter cannot enter and cause an obstruction.

4. Outside ends of ventilation ducts are high enough above grade to disperse any gas-air mixtures that might be discharged.

5. Vault/pit has sufficient ventilation to minimize the formation of combustible environment inside.

6. Vault/pit with depth of 4 feet or more has ladder or steps in good working order for ingress/egress.

- 7.2.2 While personnel are in the vault/pit, the interior environment shall be retested for combustible gas concentration and oxygen deficiency at intervals not exceeding 1 hour *unless* interior environment is being continuously monitored.

- 7.2.3 All deficiencies found shall be reported on the appropriate Regulator Station or Valve Inspection forms within ClickMobile.

- 7.3 Inspection schedule

- 7.3.1 Per §192.749, vaults housing pressure regulating and pressure limiting equipment shall be inspected at least once each calendar year at intervals not exceeding 15 months.

- 7.3.2 Vaults not covered by Paragraph 7.3.1 shall be inspected once each calendar year at an interval not exceeding 15 months.

- 7.4 Inspection records

- 7.4.1 Inspections and deficiencies shall be recorded on the appropriate Regulator Station or Valve Inspection forms within ClickMobile.

UNCONTROLLED IF PRINTED

7.4.2 Inspections of vaults shall be maintained in Maximo.

7.4.3 All information shall be retained for life of the vault.

End of Instructions.

Operator Qualification (OQ) Required?

YES.

1351: Vault Inspection and Maintenance

Appendices

NONE.

Attachments

NONE.

Compliance Requirements

29 CFR §1910.146 Permit-Required Confined Spaces

49 CFR §192.749 Vault Maintenance

Reference Documents

[LEAK 1 Leak Management: Requirements](#)

[OQAL 2.01 Operator Qualification: Covered Task List](#)

[WIGE 2.2 Working In Gaseous Environment: Personal Protective Equipment](#)

Document Rescission

VALT 2.1 Vault and Pit Inspection: Inspecting Vaults and Pits, October 1, 2020

Revision Notes

Location of Changes	Summary of Changes
Throughout Section	Environment replaces Atmosphere Updated references to WIGE from WWBG
Paragraph 4.1.5 Item 3	Added – Work Area Protection
Paragraph 4.1.6	Have at least 1 fire extinguisher on the jobsite and upwind of the work area.

VALV-Valves

VALVES

May 15, 2022

VALV 0 Table of Contents

[VALV 1 Valves: Requirements](#)

Section 1.0 Purpose

Section 2.0 Scope

Section 3.0 Target Audience

Section 4.0 Design Considerations

Section 5.0 Emergency Valves - Location

Section 6.0 Emergency Valve Inspection

Operator Qualifications (OQ)

Appendices

Appendix A - System map showing Valve ID#

Compliance Requirements

Reference Documents

Document Rescission

[VALV 2.1 Valves: Valve Installation](#)

Section 1.0 Purpose

Section 2.0 Scope

Section 3.0 Target Audience

Section 4.0 General

Section 5.0 Valve Identification

Section 6.0 Emergency Line Valves

Section 7.0 Emergency Station Valves

Section 8.0 Non-Emergency Valves

Section 9.0 Valve Installation Operations

Section 10.0 Valve Box Installations

Operator Qualifications (OQ)

Compliance Requirements

Reference Documents

Document Rescission

UNCONTROLLED IF PRINTED

VALV 2.2 Valves: Valve Inspection, Maintenance, and Repair

Section 1.0 Purpose

Section 2.0 Scope

Section 3.0 Target Audience

Section 4.0 General

Section 5.0 Valve Inspections

Section 6.0 Valve Maintenance

Section 7.0 Follow-up Maintenance

Section 8.0 Records

Operator Qualifications (OQ)

Appendices

Appendix A - Plug Valve Maintenance

Appendix B - Kerotest Gate Valve Maintenance

Appendix C - Balon Flanges Ball Valve Repair

Compliance Requirements

Reference Documents

Document Rescission

VALV 3 Valves: Approved Valves and Valve Box Accessories

Section 1.0 Purpose

Section 2.0 Scope

Section 3.0 Target Audience

Section 4.0 Plastic (PE) Ball Valves

Section 5.0 Steel Ball Valves

Section 6.0 Kerotest Gate Valves

Section 7.0 Valve Box Accessories Stock Code Table

Operator Qualifications (OQ)

Compliance Requirements

Reference Documents

Document Rescission

VALV 4 Valves: Forms and Reference Materials

References

Document Rescission

End Table of Contents.

Document Rescission

UNCONTROLLED IF PRINTED

VALV 0 Valves: Table of Contents, October 1, 2020

Revision Notes

Location of Changes	Summary of Changes
VALV 3	Section 6.0 – Spelling correction – Kerotest Gate Valves Section 7.0 - Valve Box Accessories Stock Code Table (Removed the – between Stock and Code)

VALV 1 Requirements

1.0 Purpose

This document specifies requirements for the placement and inspection of emergency valves and the installation of all valves within the Ameren Illinois (AIC) gas systems. This document complies with 49 CFR §§ 192.167, 192.179 and 192.181, 192.745 and 192.747.

2.0 Scope

This document addresses the following:

[3.0 Target Audience](#)

[4.0 Design Considerations](#)

[5.0 Emergency Valves - Location](#)

[6.0 Emergency Valve Inspection](#)

Appendices:

[Appendix A - System map showing Valve ID #](#)

3.0 Target Audience

- Gas Engineering
- Gas Supervisors
- Distribution Design Supervisors
- Distribution Design Specialists
- Gas Tech Services (GTS) Supervisor
- Gas Tech Engineering (GTE)
- Gas Storage Engineering (GSE)
- Gas Storage Supervisors

4.0 Design Considerations

4.1 Valve placement should consider the following:

4.1.1 MAOP of the operating system.

4.1.2 Intended function:

1. Emergency
2. Non-emergency
3. Isolation
4. Blow down

4.1.3 Accessibility

1. Avoid excessive depth. Efforts should be made to install valves no deeper than 40 to 48 inches, to avoid the need for protective excavation systems (i.e. shoring) when valve must be exposed for maintenance.
2. Not in bottom of ditch if possible.

4.1.4 Zones of Isolation (Outage Zones) such that re-lights can be restored within a 24 hours period.

4.1.5 Prevention of back-feed situations on multi-fed systems.

4.1.6 Other operational or potential emergency situation as designated by GTE, Gas Supervisor or Gas Engineering.

5.0 Emergency Valves - Location

5.1 Transmission Pipelines (49 CFR §192.179)

5.1.1 Each transmission line shall have sectionalizing block valves spaced such that each point on the pipeline is within a specified distance from a valve as required by. See Table 1.

Table 1 Maximum Distance from Sectionalizing Valve

Pipeline Location	Maximum distance from sectionalizing valve
Class 1	10 miles
Class 2	7-1/2 miles
Class 3	4 miles
Class 4	2-1/2 miles

5.1.2 Each section of transmission main between sectionalizing block valves shall have an emergency blow-down valve with enough capacity to blow down the line as rapidly as practicable.

1. Locate blowdown valves such that gas can be released safely, without creating a hazardous situation.

5.2 Each staffed compressor station with greater than 1,000 horsepower shall have emergency valves and emergency blow-down valves that shuts off flow into the station.

5.3 High Pressure Distribution and Distribution Lines

5.3.1 Space valves for high pressure distribution and distribution lines to effectively control gas in an emergency. Consideration should be given to:

1. Size of the area to be isolated.
2. Rivers, major highways, and railroads.
3. Number of valves necessary to isolate the area.

5.4 Regulator Station or Flow Control Station

5.4.1 Install valves used to control a regulator station or flow control station at a safe distance from the station. See [VALV 2.1](#)

A safe distance is generally accepted as 25 feet or more from the pressure control or flow control station.

5.5 Records

5.5.1 Enter details for all emergency valves, including blow-down valves, as follows:

1. AIC electronic mapping system.

System maps will distinguish these valves as Emergency Valves along with their respective Valve ID #. See [Appendix A](#).

2. Maximo

2 a. Enter the same Valve ID # as shown in the electronic mapping system.

6.0 Emergency Valve Inspection (49 CFR §192.745, §192.747)

6.1 Inspect all emergency valves once each calendar year not to exceed 15 months.

6.2 Record inspections in ClickMobile and maintain in Maximo for the life of the valve.

6.3 Include a lid marked "GAS" on any new valve box installation.

End of Instructions.

Operator Qualification (OQ) Required?

NO.

Appendices

[Appendix A - System map showing Valve ID #](#)

Attachments

NONE.

Compliance Requirements

49 CFR §192.167 Compressor stations: Emergency shutdown.

49 CFR §192.179 Transmission line valves.

49 CFR §192.181 Distribution line valves.

49 CFR §192.745 Valve Maintenance: Transmission lines.

49 CFR §192.747 Valve Maintenance: Distribution systems.

Reference Documents

[VALV 2.1 Valves: Valve Installation](#)

Document Rescission

VALV 1 Valves: Requirements, October 1, 2021

Revision Notes

Location of Changes	Summary of Changes
Paragraph 5.5.1 – Item 2.	Maximo replaces Gas Compliance System

Appendix A - System map showing Valve ID#

Open Maximo	
Facility ID	6246782
Maximo Asset Number	2145128
Installation Date	8/19/2001, 11:00 PM
Valve ID	10199604
Field Tag	10199604
Valve Diameter	6"
Material	Polyethylene
Manufacturer	Nordstrom
Manufacturer Model	NORD/KERO*842116/77311868
MAOP Design Pressure	60.00
Valve Type	Ball
Connection Type	Fusion X Weld
Emergency Valve Flag	Yes
Valve Use	System Isolation
Installation Method	Buried With Valve Box
Tee Operation	Sq Head Wrench
Clockwise to Close	Yes
Turns to Close	.25
Normal Position	Open
Outage Zone	2404
CP Type Code	None
CP System Name	001
Pressure	2009

UNCONTROLLED IF PRINTED

VALVES

October 1, 2021

VALV 2.1 Valve Installation**1.0 Purpose**

This document provides requirements for the installation of emergency and non-emergency valves in accordance with 49 CFR §§ 192.145, 192.150, 192.179, 192.181, 192.193 and 192.205 which include:

- Pipeline valves
- Storage field master and wing valves

2.0 Scope

This document addresses the following:

[3.0 Target Audience](#)**[4.0 General](#)****[5.0 Valve Identification](#)****[6.0 Emergency Line Valves](#)****[7.0 Emergency Station Valves](#)****[8.0 Non-Emergency Valves](#)****[9.0 Valve Installation Operations](#)****[10.0 Valve Box Installations](#)****3.0 Target Audience**

- Gas Engineering
- Gas Field Personnel
- Gas Supervisor
- Distribution Design Supervisors
- Distribution Design Specialist
- Gas Tech Services (GTS) Supervisor
- Gas Tech Services (GTS) Personnel
- Gas Tech Engineering (GTE)
- Gas Storage Engineering (GSE)
- Gas Storage Field Supervisors
- Gas Storage Field Operators

4.0 General

4.1 For procedures on installation of service line valves refer to [SERV 1](#).

4.2 GTE will provide the designation and location of emergency valves on:

- 4.2.1 Transmission pipelines
- 4.2.2 High pressure distribution pipelines
- 4.2.3 Pressure control or flow control stations.

4.3 Gas Engineering or Distribution Design Center (DDC/PDC) shall provide the designation and location, within the distribution system (< 100 psig), of :

- 4.3.1 Emergency valves.
- 4.3.2 Non-emergency valves.

UNCONTROLLED IF PRINTED

4.4 GSE will provide the designation and location, within gas storage field areas, of:

4.4.1 Emergency valves.

4.4.2 Non-emergency valves.

5.0 Valve Identification

5.1 Emergency valves shall be identified by identification number on distribution and transmission electronic mapping system which permits the issuing of individual valve operating instructions. See [VALV 1 Appendix A](#).

5.2 Valve numbering shall be maintained and recorded in Maximo.

5.3 All emergency valves or valve boxes shall be tagged with the valve number for easy identification in the field.

6.0 Emergency Line Valves

6.1 Transmission Pipelines (§192.150, §192.179)

6.1.1 Each point on a transmission line shall have a sectionalizing block valve spaced as specified in [VALV 1](#).

6.1.2 Each section of a transmission line installed after March 12, 1971 shall have provisions to blow down gas between sectionalizing block valves.

6.1.3 The discharge shall be located so the gas can be blown to the atmosphere without hazard. If the pipeline is adjacent to an overhead electric line, the discharge must be directed away from electric conductors.

6.1.4 Line valves installed within new or replaced transmission lines shall be capable of accommodating the passage of internal inspection devices.

6.1.5 Relief valves or regulator stations fed from a transmission line may be used as blow down devices, provided they have the capacity to blow down the transmission line as rapidly as possible.

6.2 High Pressure Distribution and Distribution Pipelines (§192.181)

6.2.1 Distribution valves that are necessary to facilitate control of gas shall be designated as emergency valves by the Gas Supervisor, Gas Engineering, DDC/PDC or GTE.

6.2.2 Valves must be spaced to effectively control gas in an emergency.

6.2.3 Zones of Isolation (Outage Zones) shall be established to support effective re-lights and emergency management.

1. The size of the zone shall be such that the majority of affected customers can have service restored within 24 hours. Refer to [VALV 1 Section 4.1.4](#).

7.0 Emergency Station Valves (§192.181)

7.1 New Pressure Control or Flow Control Stations

7.1.1 Designated stations are those subject to annual Operational and Primary Inspections. See [REGS 2.1](#).

7.1.2 Newly installed or newly designated pressure control or flow control stations shall have an emergency/fire valve installed on the inlet piping a safe distance from the station.

A safe distance is generally accepted as 25 feet or more from the pressure control or flow control station.

7.1.3 If pressure control or flow control station is on a system that has more than one source, a valve should be installed a safe distance from the station on the outlet side to eliminate back-feeding.

1. The maximum allowable distance shall be such that it allows for the effective management of a gas emergency.

7.2 Rebuilt Station Defined

7.2.1 A station rebuild is defined as:

1. Any non-maintenance type work intended to increase or decrease station capacity.
2. Any work or equipment change that increases or decreases station capacity.

7.2.2 Examples include:

1. Installation of operating standby regulator.
2. Physically relocating the regulator station.
3. Adding or removing additional pressure cuts.
4. Any work on station inlet piping that requires an interruption in the flow of gas.

7.2.3 Examples of maintenance items not considered as a "rebuild" include:

1. Replacing relief valve.
2. Replacing existing valves.
3. Replacing regulator with same or equivalent, if the purpose of the change is not to increase or decrease station capacity.
4. Installing a normally closed bypass (for inspections).
5. Adding a cathodic protection insulator.
6. Adding a valve ahead of relief valve.
7. Adding gauge taps.
8. Changing control line configuration.
9. Changing springs, orifices, liners, or ports, if the purpose of the change is not to increase or decrease station capacity.

7.3 Rebuilt Pressure Control or Flow Control Stations

7.3.1 Station Installed prior to March 31, 1971

1. Is not required to have an emergency valve on the inlet a safe distance from the station unless that station has or is going to be rebuilt as defined in [Section 7.2](#).
2. If is to be rebuilt it must have an emergency valve installed on the inlet piping in the same manner as a new station.

7.3.2 If an emergency valve exists, but does not meet the safe distance criteria, an on-site engineering evaluation shall be made to determine the availability of the valve during an emergency.

1. If the evaluation determines the emergency valve inaccessible, a new valve shall be installed at an acceptable safe distance from the station.

8.0 Non-Emergency Valves

8.1 Non-emergency valves are other valves installed through-out the gas system that improve the operation and maintenance of the system.

8.2 A non-emergency valve can be used to aid in sectionalizing or isolating areas of the system in situations requiring the shut-down of gas. These situations may include:

8.2.1 Damage to a gas main.

8.2.2 Gas main replacement or relocation project.

8.2.3 Uprating a section of the system.

8.2.4 Isolation of gas storage field wells.

8.3 Valve locations will be determined by:

8.3.1 Gas Engineering,

8.3.2 Gas Supervisor,

8.3.3 DDC/PDC,

8.3.4 GTE,

8.3.5 GSE, or

8.3.6 Gas Storage Field Supervisor.

8.4 The following locations are preferred for placement of non-emergency valves:

8.4.1 An entrance to a subdivision where a distribution main is being installed.

8.4.2 An entrance to a dead-end street with a cul-de-sac that is not part of a subdivision.

8.4.3 An entrance to a subdivision ending with a cul-de-sac that has more than 30 houses.

8.4.4 Within a main segment, such that a maximum of approximately 300 customers would be isolated by a set of valves.

8.4.5 Gas storage field wells.

8.5 Valves can have an assigned identification number and be entered on the gas electronic mapping system.

8.6 Valve can be entered in Maximo and designated as Non-Emergency Valve.

8.6.1 Maximo will maintain a listing, location, and attributes of Non-Emergency valves.

Be careful to enter the correct valve designation in Maximo so that an Emergency Valve is not inaccurately entered as Non-Emergency.

Some areas initially enter a valve as Non-Emergency until the valve is inspected. The valve designation is changed to "Emergency" when the inspection is entered to be scheduled for annual inspection.

8.6.2 Non-emergency valves do not require annual inspection.

8.6.3 Maximo will maintain a listing, location, and attributes of Non-Emergency valves.

8.7 If a below grade non-emergency valve is used to isolate or sectionalize gas main segments of a gas distribution system or transmission system during an emergency situation, the valve will be designated as an Emergency Valve after the emergency situation has been resolved.

8.7.1 An Emergency Valve ID shall be assigned.

8.7.2 The valve shall be entered into Maximo and on the electronic gas system map.

8.7.3 In the comments section of the ClickMobile valve inspection form, enter "valve was used during an emergency situation".

8.7.4 This does not apply to a below grade service line valve used to shut down a service line.

9.0 Valve Installation Operations

9.1 Steel Valves (§192.145)

9.1.1 The valve must have at least the minimum design rating for the Design MAOP of the system in which it is being installed.

9.1.2 The valve body must be compatible with the pipeline and/or gas storage field wells to which it is being connected.

9.1.3 Welded valves must be installed by a qualified welder using an approved welding procedure. See [WELD 2.3](#) and [WELD 4](#) for welding procedure specifications (WPS).

Generally, the valve should be in the closed position during welding to prevent damage to the valve seats.

1. Consult the valve manufacturer's instructions for the position of the valve during welding operations.

9.1.4 Flanged end valve shall have the appropriate gasket installed.

1. Bolting procedures for the flange shall be in accordance with [STLP 3.3](#).

9.1.5 Screwed end valves shall have a suitable threading compound (e.g. Real-Tuff, Megaloc, Slic-tite) applied sparingly to the threads of the pipe to which the valve is being installed. See [STLP 1 Table 2](#).

1. Apply the wrench to the valve end adjacent to pipe being attached.

9.1.6 Above ground valves shall be properly coated/painted as protection against atmospheric corrosion. See [CORR 2.3](#).

9.1.7 Prior to installation the Gas Supervisor or Gas Engineering should consult with Corrosion Control personnel to determine if an insulator kit should be installed in the proposed valve. See [CORR 2.1](#).

9.2 Polyethylene (PE) Ball Valves (§192.193)

9.2.1 The valve shall be pressure rated to meet the Design MAOP of the system in which it is being installed.

9.2.2 PE valves can be attached to the pipe by either butt fusion or electrofusion couplings. See [POLY 2.4](#) Butt Fusion or [POLY 2.5](#) Electrofusion for fusion information and requirements.

9.2.3 If a PE valve is being installed close to the transition fitting between steel and PE section of main, a test wire from the steel pipe and the tracer wire should be brought up inside the valve box.

Test wire and tracer wire shall be separate and not connected.

9.2.4 A PE valve shall be installed and backfilled adequately to prevent undue stress or strain on the PE main when the valve is operated.

9.3 All Valves

9.3.1 Valve should be located in a readily accessible location that is protected from damage due to:

1. Tampering.
2. Excessive outside forces.
3. Traffic loads.

9.3.2 Backfill around valves shall be adequately compacted to provide support to minimize stress and strain on the pipe when the valve is operated.

9.3.3 Efforts should be made to install valves no deeper than 40 to 48 inches, to avoid the need for protective excavation systems (i.e. shoring) when valve must be exposed for maintenance.

9.3.4 Valves located in rural areas should have a pipeline marker installed near the valve box.

10.0 Valve Box Installations

10.1 Any new valve installation, either steel or PE, must include the appropriate valve box and lid marked "GAS".

10.2 Any new valve installation, either steel or PE, may include a concrete pad around the valve box lid for future locating.

10.3 Install the correct valve box for the size and type of valve installed

10.4 The valve box must be independent of (i.e. not structurally supported by) the pipeline.

10.5 Backfill around the valve box should be compacted in approximately 12-inch layers to minimize settlement. When backfilling, take care not to knock or move the valve box out of alignment with the valve.

End of Instructions.

UNCONTROLLED IF PRINTED

Operator Qualification (OQ) Required?

NO.

Appendices

NONE.

Attachments

NONE.

Compliance Requirements

49 CFR §192.145 Valves

49 CFR §192.150 Passage of internal inspection device

49 CFR §192.179 Transmission line valves

49 CFR §192.181 Distribution line valves

49 CFR §192.193 Valves installation in plastic pipe

Reference Documents

[CORR 2.1 Corrosion Control: Cathodic Protection Design](#)

[CORR 2.3 Corrosion Control: Coatings](#)

[POLY 2.4 Polyethylene Pipe: Butt Fusion](#)

[POLY 2.5 Polyethylene Pipe: Electrofusion](#)

[REGS 2.1 Regulator Stations: Regulator Station Inspections](#)

[SERV 1 Service Line Installation: Requirements](#)

[STLP 3.3 Steel Pipe: Flanges](#)

[VALV 1 Valves: Requirements](#)

[WELD 2.3 Welding: Construction of Pipelines](#)

Document Rescission

VALV 2.1 Valves: Valve Installation, October 1, 2020.

Revision Notes

Location of Changes	Summary of Changes
1.0 Purpose	Added reference to 49 CFR §§192.145, 192.150 and 192.193
Subsection 6.1	Added reference to 49 CFR §192.150, §192.179
Paragraph 6.1.4	New: Transmission line valves installed within new or replaced transmission lines shall be capable of accommodating the passage of internal inspection devices.
Subsection 6.2	Added reference to 49 CFR §192.181
Section 7.0 – Emergency Station Valves	Added reference to 49 CFR (§192.181)

Subsection 9.1	Added reference to 49 CFR (§192.145)
Subsection 9.2	Added reference to 49 CFR (§192.193)
Compliance Requirements	Added: 49 CFR §192.145 Valves 49 CFR §192.150 Passage of internal inspection device 49 CFR §192.193 Valves installation in plastic pipe

VALVES

October 1, 2022

VALV 2.2 Valve Inspection, Maintenance, and Repair

1.0 Purpose

This procedure describes the inspection and maintenance procedures for all transmission, distribution emergency valves and gas storage field emergency and non-emergency valves in accordance with 49 CFR §§ 192.745 and 192.747.

2.0 Scope

This document addresses the following:

[3.0 Target Audience](#)

[4.0 General](#)

[5.0 Valve Inspections](#)

[6.0 Valve Maintenance](#)

[7.0 Follow-up Maintenance](#)

[8.0 Records](#)

Appendices:

[Appendix A - Plug Valve Maintenance](#)

[Appendix B - Kerotest Gate Valve Maintenance](#)

[Appendix C - Balon Flanges Ball Valve Repair](#)

3.0 Target Audience

- Gas Engineering
- Gas Field Personnel
- Gas Supervisor
- Gas Tech Services (GTS) Supervisor
- Gas Tech Services (GTS) Personnel
- Gas Tech Engineering (GTE)
- Gas Storage Engineering (GSE)
- Gas Storage Field Supervisors
- Gas Storage Field Operators
- Gas Control

4.0 General

- 4.1 Communicate with Gas Control, before and after, when any inspection and/or maintenance work is scheduled to be performed on any valve that is monitored through the SCADA system and/or operated remotely by Gas Control.

5.0 Valve Inspections

- 5.1 The following valves shall be inspected and partially operated each calendar year, at intervals not exceeding 15 months:
- 5.1.1 Transmission, distribution, and station emergency valves.
 - 5.1.2 Gas storage field emergency valves.
 - 5.1.3 Gas storage field master and wing valves.
- 5.2 Check and verify for the presence of the valve identification tag/label.

UNCONTROLLED IF PRINTED

- 5.2.1 Verify valve id on tag/label is correct and is readable.
- 5.2.2 Replace or schedule for replacement if necessary.
- 5.3 Review, verify, correct or furnish missing data on the ClickMobile map and valve inspection form.
- 5.4 The valve box shall be inspected for alignment and obstructions that might preclude access to the valve adapter.
- 5.5 Ensure valve wrench fits properly on the valve adapter head.
- 5.6 When partially operating a Quarter Turn valve, take care to ensure valve is returned to its normal operating position.
 - 5.6.1 If necessary remove dirt or debris and perform visual check.
- 5.7 Partially operate manual valve or motor valve. Return valve to normal operating position.

VERY IMPORTANT: Make sure those normally closed valves which separate two systems that operate at different pressures are left in the **CLOSED** position.

- 5.8 Below ground valve shall be checked for leakage with an approved gas detection instrument that reads percent of gas-in-air on the LEL and Gas scale.
 - 5.8.1 Perform a final leakage check at the conclusion of the inspection.
- 5.9 Above ground valves shall be checked for leakage with either a leak detection instrument or leak detection fluid at the conclusion of the valve inspection.
- 5.10 Check for atmospheric corrosion on valves and piping installed above ground or in a vault/pit. See [CORR 1](#).
- 5.11 Unknown or inaccurate valve description and installation data that can be accessed without excavation or disruption of service shall be verified and entered onto the Click-Mobile inspection form.
- 5.12 Pressure control station emergency valves may be inspected and maintained during the annual pressure control station inspection.
- 5.13 If valve is in a vault, a vault inspection shall also be completed as per [VALT 2.1](#).

6.0 Valve Maintenance

- 6.1 Before operating the plug valve, lubricate to lift the plug and shear the grease.
- 6.2 After operating the plug valve, lubricate to replace grease loss due to operating.
- 6.3 Maintenance information for plug valves is provided in [Appendix A](#) which includes:
 - 6.3.1 Safety practices.
 - 6.3.2 Valve cleaner stock codes.
 - 6.3.3 Troubleshooting seized or difficult to turn valve.
 - 6.3.4 Lubricating procedures.
 - 6.3.5 Valve flush procedures.

UNCONTROLLED IF PRINTED

- 6.3.6 Lubricant stock codes.
- 6.3.7 Plug valve lubrication extension assembly.

Regulator station inlet plug valves should only be lubricated when difficult to turn to prevent accumulation of excess grease in downstream regulators.

- 6.4 Maintenance information for Kerotest gate valves is included in [Appendix B](#).
 - 6.4.1 Troubleshooting a valve that will not shut off.
 - 6.4.2 Troubleshooting repacking a valve.
 - 6.4.3 Repacking procedures:
 - 1. Zero pressure repacking.
 - 2. Primary repacking.
 - 3. Secondary repacking.
 - 6.4.4 Bonnet leak repair.
- 6.5 Maintenance and repair information for the Balon Ball Valves is provided in [Appendix C](#), which includes:
 - 6.5.1 Parts that are contained in the repair kit for various ball valve series.
 - 6.5.2 Balon parts listing for Series F and S lever operated valves.
 - 6.5.3 Repair procedures for the Series F and S lever operated valves.
- 6.6 Complete the following maintenance items at the time of the scheduled valve inspection:
 - 6.6.1 Paint valve box lid if needed.
 - 6.6.2 Straighten or adjust valve box if needed.
 - 6.6.3 Clean-out valve box if needed.
 - 6.6.4 Replace missing valve identification tag/label.
 - 6.6.5 Repair leaks.
 - 6.6.6 All below ground leaks, and aboveground leaks not repaired at the time of the inspection, must be classified and recorded in accordance with [LEAK 1 Section 5.0](#) Leak Detection and Classification.
- 6.7 Verify that the valves are properly shown on the reference maps to allow easy location.
 - 6.7.1 Measurements associated with the sketch in ClickMobile shall be checked to ensure they are reasonably correct.
- 6.8 Following maintenance of a valve, notify Gas Control that valve operation has returned to normal, if Gas Control is monitoring the valve.

7.0 Follow-up Maintenance

- 7.1 If gas field personnel determine an emergency valve is inoperable or is removed from service, the Gas Supervisor shall be notified immediately.

UNCONTROLLED IF PRINTED

- 7.1.1 An alternate valve shall be identified and designated for the purpose of controlling the flow of gas in an emergency OR
- 7.1.2 Maintenance shall be performed on the emergency valve to make it operable within the designated compliance date of that valve's annual inspection.
- 7.2 Gas Supervisor should review the inspection sheets and other maintenance work listed in Maximo.
 - 7.2.1 Maintenance work that can be reported during valve inspection includes:
 - 1. Replacement of valve number tags
 - 2. Miscellaneous work
 - 3. Mechanical maintenance
 - 4. Lubricate valve
 - 5. New insulator needed
 - 6. New gasket needed
 - 7. Data correction
 - 8. Clear vegetation
 - 9. Clear valve box
 - 10. Clean internal (flush)
 - 11. Clean external
 - 12. Bond wire
 - 13. Align valve box.

8.0 Records

- 8.1 Record on the ClickMobile inspection form the results of all emergency valve and gas storage field non-emergency valve inspections by those performing the inspection:
 - 8.1.1 Qualified gas field personnel,
 - 8.1.2 GTS personnel, or
 - 8.1.3 Gas storage field personnel.
- 8.2 Any data correction or update should be reported on the ClickMobile inspection form.
 - 8.2.1 Gas Supervisor, Gas Engineering, GTS Supervisor, GTE, Gas Storage Field Supervisor or GSE is responsible for ensuring data corrections are made within Maximo.
- 8.3 The results of the emergency valve inspection shall be entered into ClickMobile and maintained within Maximo.
- 8.4 The results of the inspection shall be maintained for life of the facility.

End of Instructions.

Operator Qualification (OQ) Required?

YES

0141: Visual Inspection for Atmospheric Corrosion

UNCONTROLLED IF PRINTED

- 0301 : Manually Opening and Closing Valves
- 0321: Valve - Corrective Maintenance
- 0331: Valve - Visual Inspection and Partial Operations
- 0341: Valve - Preventive Maintenance
- 0351 : Pneumatic Actuator/Operator Inspection and Testing, Preventive and Corrective Maintenance
- 0361: Electric Actuator/Operator Inspection and Testing, Preventive and Corrective Maintenance
- 0371: Hydraulic Actuator/Operator Inspection and Testing, Preventive and Corrective Maintenance
- 1371: Operate Gas Pipeline – System Control Center Operations

Appendices

[Appendix A - Plug Valve Maintenance](#)

[Appendix B - Kerotest Gate Valve Maintenance](#)

[Appendix C - Balon Flanges Ball Valve Repair](#)

Attachments

NONE.

Compliance Requirements

49 CFR §192.745 Valve maintenance: Transmission lines.

49 CFR §192.747 Valve maintenance: Distribution lines.

Reference Documents

[CORR 1 Corrosion Control: Requirements](#)

[LEAK 1 Leak Management: Requirements](#)

[VALT 2.1 Vault and Pit Inspection: Inspecting Vaults and Pits](#)

Document Rescission

VALV 2.2 Valves: Valve Inspection and Maintenance, October 1, 2021

Revision Notes

Location of Changes	Summary of Changes
Appendix A-3 – Valve Cleaners	A-3.1 - Revise – Valve cleaners should be used on hard to turn or seized valves, see A-4, prior to lubrication.
Appendix A-7 – Lubrication gun	A-7.4 – Added – injection – Try to keep the injection pressure above 1500 psi.
Appendix B-1 – Kerotest Gate Valve Maintenance	B-1.2 – New – Kerotest recommends installing packing shims as a first attempt to stop a stem packing leak. The procedure can be found in <u>VALV 4 Kerotest Model -1 Gate Valve Operations Manual</u>

UNCONTROLLED IF PRINTED

Appendix A - Plug Valve Maintenance

A-1. General

- A-1.1 Routine maintenance with the proper lube sealant is the best assurance for trouble free valves.
- A-1.2 Plug valve lubrication makes the plug and valve body surface slippery to ease turning and reduce friction and galling.
- A-1.3 It also acts as a sealant.
- A-1.4 The tapered plug acts as a scraper.
- A-1.5 Each time a plug valve is operated, the plug scrapes a small amount of lubricant from the sides of the valve body.
- A-1.6 This reduces the lubricant film and allows the tapered plug to sink further into the body.

A-2. Safety Practices

- A-2.1 Install a gauge and a relief fitting on the outlet of the lubricating grease gun so that the pressure on the valve does not exceed the maximum pressure.
- A-2.2 Lubricating grease guns can create pressures in excess of 6,000 psig. Follow maintenance procedures when flushing or greasing.
- A-2.3 The maximum pressure used on the lubricant, when greasing a cast iron or semi-steel valve, is 4,000 psi.
 - A-2.3.1 If this pressure does not free the valve, consult a factory-trained valve maintenance technician.
- A-2.4 Do not exceed 4,000 psi on valves 4 inch and smaller and 6,000 psi on valves 6 inch and larger.
 - A-2.4.1 Consult manufacturer's catalog or assess the general condition of the valve to determine a safe injection pressure.

1. Never remove the coupler before opening the bleeder valve on the gun.
2. Keep hand away from the coupler and wiggle the hose to release trapped pressure.

A-3. Valve Cleaners

- A-3.1 Valve cleaners should be used on hard to turn or seized valves, see [A-4](#), prior to lubrication
- A-3.2 Valve cleaner, which softens old hardened grease, can be injected using a high-pressure valve lubricant gun.
- A-3.3 A nonflammable valve cleaner shall be of sufficient strength to clean the valve within 10-30 minutes. The cleaner should also contain lubricant that allows the valve to operate before the injection of the regular lubricant.

If the cleaner does not have lubricating qualities, the valve may seize.

A-3.4 Consider removing the grease extension rather than flushing all the grease in the extension through the valve.

A-3.5 [Table A1](#) provides list of available stock coded valve cleaners.

A-3.5.1 Equivalent valve cleaner can be purchased from appropriate vendors.

A-3.5.2 Valve cleaners have a short shelf life; order only as needed.

Table A1 Valve Cleaners

Product Name	Packaging	Stock Code
Sealweld Valve Cleaner	12 Ounce Cartridges, 16 per Case	31 56 361
Val-Tex Valve Flush	1 Quart Bottles, 4 per Case	15 52 738

A-4. Seized or Difficult to Turn Valves

A-4.1 Eventually, the valve will leak or stick.

A-4.2 If plug valve is hard to turn, flush it with valve cleaner and re-grease it. Never force a hard turning valve.

A-4.3 If possible, lubricate and clean plug valves in the open position so that the body and plug lubrication channels are in alignment (see [Figure A1](#)).

When the valve is lubricated in a closed position, the lubricant cannot spread over the entire surfaces of the plug and body.

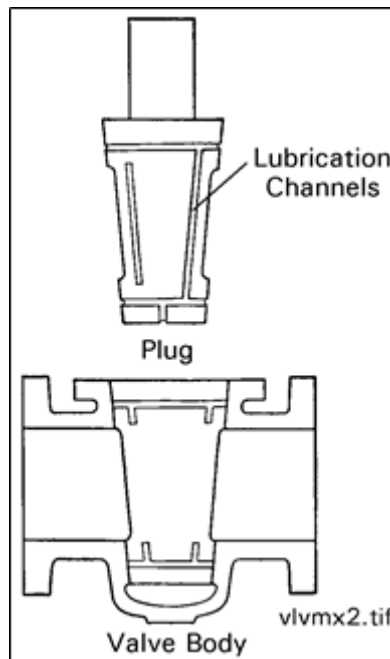

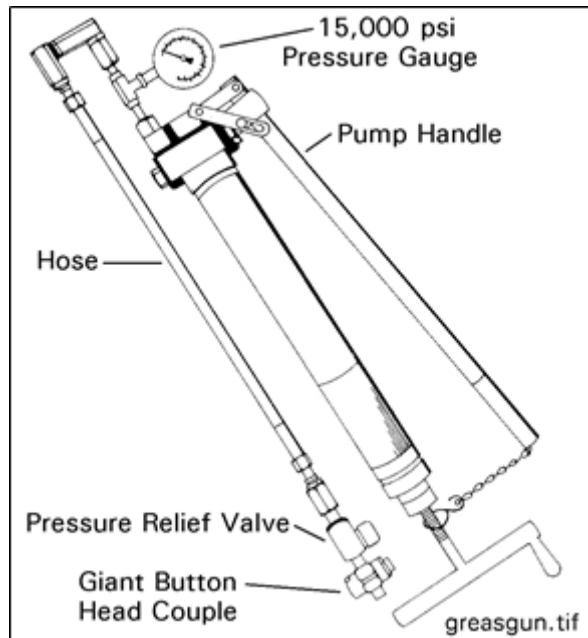

Figure A1 - Typical Plug Valve Lubrication Channels and Typical Grease Gun

A-4.4 See [A-5](#) for lubrication procedure.

A-4.5 To align the lubrication channels, fully open or fully close the valve.

A-4.6 Inject valve cleaner into the valve slowly to allow simultaneous and equal distribution of the cleaner.

A-4.7 If the pressure gauge indicates the material is not moving, allow the cleaner to sit under pressure.

A-4.8 After 10-30 minutes, pump additional cleaner into the valve.

A-4.9 If the valve still shows signs of being restricted, try to operate the valve a few degrees (being careful not to open or close valve) while continuing to pump cleaner into the valve to dislodge some of the deposits.

A-4.10 Re-grease the valve after the hardened deposits have been removed.

A-4.10.1 Inject valve grease into the valve by hand pumping the grease gun slowly.

A-4.10.2 The pressure gauge should climb steadily.

A-4.10.3 Continue pumping grease as long as the valve takes pressure and volume.

A-4.10.4 At some point, the gauge needle should drop off.

a. Drop in pressure generally means the plug has unseated, indicating a fully lubricated valve.

b. This point can also be felt when the pumping effort declines.

A-4.11 Operate the valve a few degrees to check ease of operation.

A-5. Lubrication Procedure

A-5.1 Make sure the valve is in the full open position.

A-5.2 Load the gun with the proper amount of lube sealant called for in [Table A2](#) or valve manufacturer's instructions.

A-5.2.1 Return the piston in the hydraulic gun to the desired depth using the markings on the gun handle.

A-5.2.2 Do not force the stick into the barrel.

A-5.2.3 If the stick is out of round, before unwrapping, roll it in your hands and reduce the diameter.

A-5.2.4 Rewrap any unused portion.

A-5.3 Pump the lube sealant into the valve.

It takes approximately 44 strokes of a hydraulic gun to pump one ounce of material, or approximately 350 strokes for 8 ounces (one "J" size stick)

A-5.4 If the valve continues to leak. The sealing surfaces may be severely worn or damaged. Consider the following options:

A-5.4.1 If you have been using bulk lube sealant, try injecting stick grade which has a higher viscosity.

A-5.4.2 Remove the stops and rotate the plug 180 degrees. This will reposition the damaged surfaces.

A-5.5 As a last resort, TFE filled lube sealant may be used. Repeat use of this lube sealant is not recommended. Consult VAL-TEX for further information.

A-5.6 Solid fillers in lubricants or sealants are a major cause of plug valve malfunctions.

Table A2 Valve Lube Sealant Capacity in Ounces

Size (inches)	Cameron Ball Valve	Grove Ball Valve	Nordstrom-Audco-Walworth Plug Valve	Size (inches)	Cameron Ball Valve	Grove Ball Valve	Nordstrom-Audco-Walworth Plug Valve
1/2			1/2	20	43	11	72
3/4			1/2	22		11	80
1			1	24	51	13	88
1-1/2			1	26		14	96
2	5		3	28	60	14	
3	7		4	30	64	15	112
4	9		5	32		17	
6	13	3	9	34		17	
8	17	3	11	36	76	18	
10	21	4	14	38		19	
12	26	5	17	40		20	
14	30	5	32	42	89	21	
16	34	7	40	48	102	24	
18	38	9	56				

Note: When using Valve Flush it may be necessary to perform flushing procedure twice.

A-6. Valve Flush

UNCONTROLLED IF PRINTED

A-6.1 Before using Valve Flush, try to turn the valve.

A-6.1.1 This could loosen some of the particles that are binding the plug.

A-6.2 Ensure valve is in the full open position.

A-6.3 Tighten the bonnet bolts snugly with a box or open-end wrench.

Use a crisscross method to ensure even tightening of bonnet bolts..

A-6.4 Add Valve Flush equal to the sealant capacity listed for the valve in [Table A2](#) or valve manufacturer's instructions.

A-6.5 Load the required amount of Valve Flush into the gun and pump it into the valve.

Do not exceed 4,000 psi on valves 4" and smaller and 6,000 psi on valves 6" and larger. Consult manufacturer's catalog or assess the general condition of the valve to determine a safe injection pressure.

A-6.6 Use the markings on the gun handle to determine how far to push the piston down.

A-6.6.1 Each mark is 1-1/8" and is equal to approximately 1 ounce.

A-6.7 After injecting Valve Flush, let it soak for 30 minutes or long as possible to allow time to soften the hardened deposits.

Open the by-pass valve on the gun before removing the coupler from the fitting.

A-6.7.1 Keep your hand away from the coupler and wiggle the hose to release any trapped pressure.

A-6.8 Flex the valve approximately 10 times by turning it from an open to a closed position.

A-6.8.1 Any valve that cannot be closed completely should be closed as much as possible.

A-6.9 Attempt to tighten the bonnet bolts again.

A-6.10 If required, repeat the procedure from step [A-6.5](#).

A-7. Lubrication Gun will not build pressure

A-7.1 Check for seepage around the fitting.

A-7.2 Inspect the coupler washer and the fitting for defects or trash.

A-7.3 Check for leakage around the bonnet. Tighten the bonnet bolts again.

A-7.4 Try to keep the injection pressure above 1500 psi.

UNCONTROLLED IF PRINTED

A-7.5 If the pressure drops rapidly or never builds, after checking for leakage, you are probably relieving in one or two veins only.

A-7.5.1 You can try to build a false blockage by injecting a small amount of lube sealant (approximately 10%-20% of its capacity) to temporarily plug the open veins and allow the Valve Flush to build pressure against the veins that are still clogged.

A-7.5.2 Then try the flush procedure again until full amount of Valve Flush has been injected.

A-8. Lubricants

A-8.1 The solids content of stick type lubricants is much greater than that of greases packaged in pails or cartridges.

A-8.2 While stick form lubricant is easier to handle, the lubricating qualities are greatly reduced.

A-8.3 Grease cartridges can be loaded into a grease gun with an ez-loader assembly, making it easier to handle.

A-8.4 See Table 3 for a list of available lubricants that are stock coded. Equivalent lubricants can be purchased from appropriate vendors.

Table A3 Valve Lubricants

Lubricants		
Product Name	Packaging	Stock Code
Val-Tex #80	Box of Size B, 3/8" Diameter, Sticks, 24 per Box	31 56 325
Val-Tex #80 or Rockwell #555	Box of Standard Size K, 1-1/2" Diameter, Sticks, 12 per Box	31 55 237
Sealweld #911	Case of 12 Ounce Cartridges, 16 per Case	31 56 324

A-8.4.1 Sealweld #911 is a last resort lubricant. #911 contains PTFE and requires a separate device that attaches to grease gun to load grease into gun. #911 is designed for valves that are leaking by and will fill voids up to 0.010 inches.

A-8.4.2 Size B, C, D, sticks are for use in the Mini-Mite. Size of Mini-Mite and sticks used depends on the size of the meter valve being lubricated. In addition to these, Sizes A and G sticks are for use in the Mini-Mite. The Size A stick is 1/4" diameter and the G stick is 5/8" diameter.

A-8.4.3 Size K stick is for use in the 10,000 psi and the 15,000 psi High Pressure Screw Prime Valve Lubricant Gun.
Size J stick is for use in the 10,000 psi High Pressure Hydraulic Valve Lubricant Gun.

A-9. Plug Valve Lubrication Extension

A-9.1 Plug valve lubrication extensions can be used with stem lubricated plug valves, 2 inch and over.

A-9.2 Lubricate valves each year, more often if operated frequently.

A-9.3 Fill rod with lubricant before installing. Extension requires hollow-handle rod for valve operation.

A-9.4 Figure A2 illustrates a typical below ground plug valve with a lubrication extension.

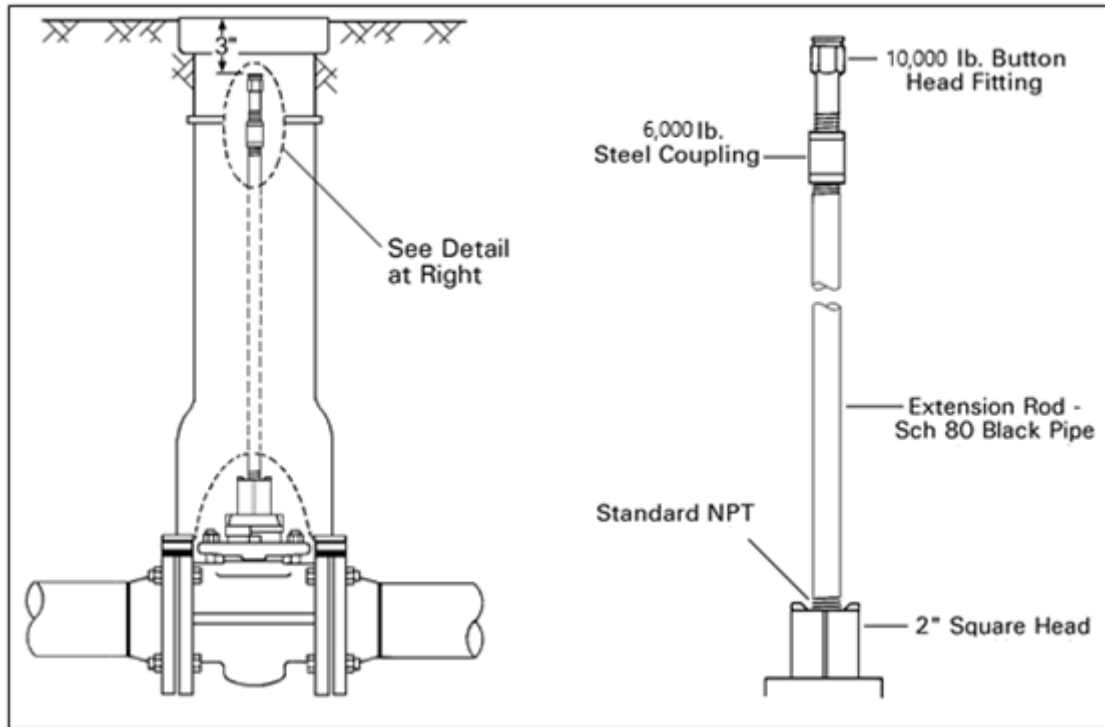

Figure A2 - Typical Plug Valve Lubrication Extension Installation

(See [Table A4](#) for stock codes)

- A-9.5 Use standard giant button head fitting furnished with valve, or order separately for valves having manual type screw.
- A-9.6 Size extension rod and fittings to tap in valve up to a maximum of 3/8" diameter.
- A-9.7 Use reducing fittings for larger size taps.
- A-9.8 Protect rod and all exposed threads with a cold applied tape (i.e. cold applied wax tape).
- A-9.9 Extension can also be made with 3/8 inch stainless steel tubing and Swagelok fittings.
- A-9.10 Plug valves without 2 inch square operating nut require a 2 inch square adapter fitting.
- A-9.11 Table A4 lists stock code for items shown in [Figure A2](#):

Table A4 Stock codes for Valve Lubrication Fittings

Stock Code	Description
19 23 824	Steel Coupling, 1/4" 6,000 lb
19 23 826	Steel Coupling, 3/8" 6,000 lb
19 22 466	Button Head Fitting, 1/4" 10,000 lb
19 22 467	Button Head Fitting, 3/8" 10,000 lb
32 23 087	Extension Rod, 1/4"Sch 80, Black Pipe
32 23 091	Extension Rod, 3/8"Sch 80, Black Pipe

Appendix B - Kerotest Gate Valve Maintenance

B-1. General

UNCONTROLLED IF PRINTED

- B-1.1 This section provides a procedure for performing maintenance on Kerotest gate valves.
- B-1.2 Kerotest recommends installing packing shims as a first attempt to stop a stem packing leak. The procedure can be found in [VALV 4 Kerotest Model M-1 Gate Valve Operations Manual](#)
- B-1.3 The repacking procedures are categorized as follows:
 - B-1.3.1 Primary - Condition 1: Valve under pressure
 - B-1.3.2 Secondary - Condition 2: Valve under pressure and Primary procedure was unsuccessful
 - B-1.3.3 Zero - Condition 3: Valve under zero pressure
- B-1.4 Manufacturer or vendor can be consulted for any updates to maintenance or repair procedures.
- B-1.5 For components of Kerotest Gate Valve see Figure B1.

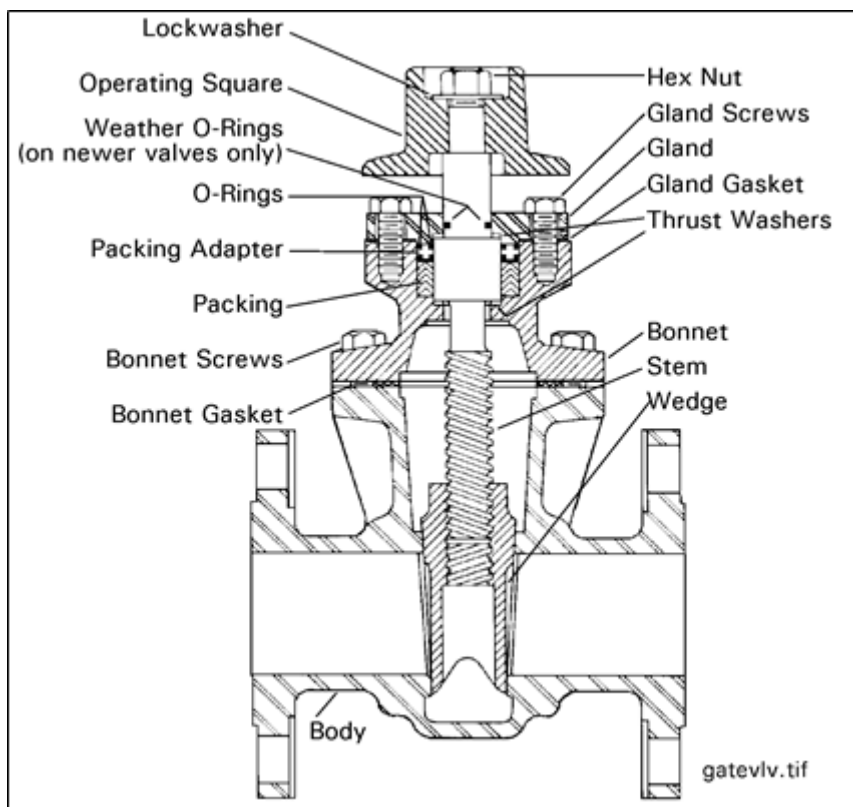

Figure B1 Kerotest Gate Valve Diagram

B-2. Troubleshooting

B-2.1 Valve will not shut off

- B-2.1.1 When pipeline valves remain in an open position for a period of time, sediment or dirt may collect inside the valve.
 1. Slowly close these valves, throttling them for a short time so the turbulence flushes away any sediment or dirt that might have settled in the valve.
 2. In the event of an emergency close the valve without throttling.
- B-2.1.2 When complete shutoff is not obtained, the valve can be reseated as follows:

UNCONTROLLED IF PRINTED

1. Drive wedge into seats with moderate effort.
2. Turn back 1 to 2 complete turns and again drive into seats with moderate effort.
3. Continue this procedure until shutoff is obtained.

B-2.2 Repacking Valve

B-2.2.1 Malfunction of the packing seal may be caused by worn packing.

B-2.2.2 Repack valve as outlined in sections B-3, B-4, and B-5.

B-3. Zero (Condition 3) Pressure Repacking Procedure

B-3.1 Refer to drawing [Figure B2](#) for steps B-3.2 through B-3.10.

B-3.2 Close valve tightly with wrench.

B-3.3 Remove nut (1), lock washer (2), and operating square (3).

B-3.4 Remove all cap screws (4) and gland (5).

B-3.4.1 Upper thrust washer (7) may remain in gland (5) or on stem square (11).

B-3.5 Rotate stem square (11) in same direction as when closing the valve until it is free from the wedge.

B-3.5.1 Withdraw stem from valve.

B-3.5.2 Lower thrust washer (13) may remain in the cover or on the stem square (11).

B-3.6 Remove:

B-3.6.1 Top packing adapter (8).

B-3.6.2 V-rings (9).

B-3.6.3 Lower packing adapter (10).

B-3.7 Replace lower thrust washer (13) in cover if removed.

B-3.8 Lubricate new parts with light oil and insert in packing chamber as follows:

B-3.8.1 Lower packing adapter (10).

B-3.8.2 V-rings (9).

B-3.8.3 Top packing adapter (8).

B-3.9 Insert stem square (11) in cover and rotate slowly by hand in the direction for opening valve. Continue rotation until stem shoulder (12) contacts lower thrust washer (13).

B-3.10 Check if upper thrust washer (7) is in place. Position gasket (6) and gland (5) on cover. Insert cap screws (4) fully and tighten. Place operating square (3) and lock washer (2) on stem and then secure with nut (1).

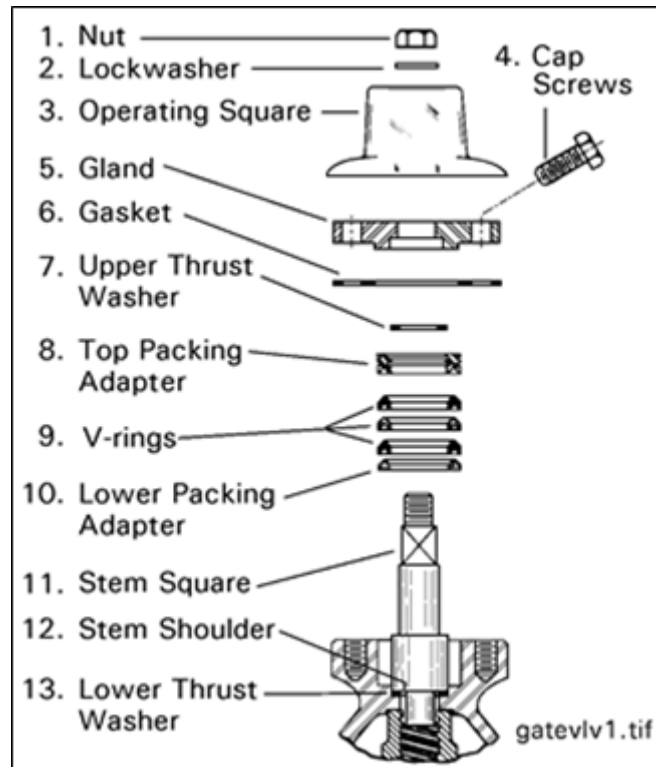

Figure B2 Kerotest Packing Diagram

B-4. Primary (Condition 1) Repacking Procedure

- B-4.1 Not recommended for pressures greater than 90 psig.
- B-4.2 Refer to drawing [Figure B2](#) for steps B-4.3 through B-4.13.
- B-4.3 Open valve fully. Backseat to form a seal between lower thrust washer (13) and stem shoulder (12).
- B-4.4 Remove nut (1), lock washer (2), and operating square stem (3).
- B-4.5 Remove **only** two of the cap screws (4).
- B-4.6 Replace with two all thread studs (size and length recommended in [Table B1](#)).
- B-4.7 Thread all thread studs into cover until they bottom. Install a nut on each stud and tighten.
- B-4.8 Remove all remaining cap screws (4).
- B-4.9 Slowly and evenly loosen the two nuts on the all thread studs, watching that the studs do not unthread from cover as the nuts are turned.
 - B-4.9.1 If gland rises as the nuts are loosened, backseat seal has not been obtained.
 - B-4.9.2 Retighten nuts, replace and retighten missing bolts, and then reattempt backseat seal.
 - B-4.9.3 Continue to loosen nuts until the top of the nuts are flush with the top of the safety studs.
- B-4.10 Rotate stem slowly with open end wrench on stem square (11) until pressure pops packing. Backseat immediately.

Grip end of wrench and keep fingers clear. Pressure may slam gland against wrench when packing pops.

- B-4.10.1 If packing does not pop out, replace gland. Retighten nuts on all thread studs, and replace and tighten remaining cap screws (4).
- B-4.10.2 Close valve tightly and refer to [B-5](#) Secondary Repacking Procedure. Continue with step [B-5.6](#).
- B-4.11 Remove nuts and gland (5).
 - B-4.11.1 Upper thrust washer (7) may remain in gland (5) or on stem square (11).
- B-4.12 Remove top packing adapter (8), V-rings (9), and lower packing adapter (10).
- B-4.13 Lubricate new parts with light oil and insert in packing chamber as follows:
 - B-4.13.1 Lower packing adapter (10).
 - B-4.13.2 V-rings (9).
 - B-4.13.3 Top packing adapter (8).

A slight leak in the backseat seal can cause difficulty in replacing the V-rings; a straightened paper clip or smooth wire can be used on the side of the V-rings to allow pressure to vent until the adapter can be quickly inserted and the gland bolted down.

- B-4.14 Place upper thrust washer (7) on stem square (11) if removed.
- B-4.15 Position gasket (6) and gland (5) on cover.
- B-4.16 Insert cap screws (4) fully and tighten.
- B-4.17 Place operating square (3) and lock washer (2) on stem square and then secure with nut (1).

Table B1 All Thread Stud Sizes

Valve Size	Stud & Nut Size	Stud Length
1-1/4"	5/16" - 18 UNC	2"
2" & 3"	3/8" - 16 UNC	2-1/2"
4", 6", 8"	3/8" - 16 UNC	3"
10" & 12"	1/2" - 13 UNC	4-1/4"
16"	3/4" - 10 UNC	6-1/4"

B-5. Secondary (Condition 3) Repacking Procedure

- B-5.1 Not recommended for pressures in excess of 90 psig.
- B-5.2 Refer to drawing [Figure B2](#).
- B-5.3 Close valve tightly with wrench.
- B-5.4 Remove nut (1), lock washer (2) and operating square (3).

UNCONTROLLED IF PRINTED

Before proceeding, remember: If the valve was closed under pressure, the pressure is trapped in the body cavity. When the stem or packing is removed, this pressure will bleed from the body. Therefore, this procedure is not recommended for pressures in excess of 90 psig.

- B-5.5 Remove only two of the cap screws (4).
- B-5.6 Replace with two all thread studs (size and length recommended in table below).
- B-5.7 Thread all thread studs into cover until they bottom. Install a nut on each stud and tighten.
- B-5.8 Remove all remaining cap screws (4).
- B-5.9 Slowly and evenly loosen the two nuts on the all thread studs, watching that the studs do not unthread from cover as the nuts are turned.
 - B-5.9.1 If gland and packing rise as nuts are loosened, continue to slowly loosen nuts until the trapped pressure begins to bleed.
 - B-5.9.2 If the bleeding pressure does not diminish, successful seat shutoff has not been obtained.
 - B-5.9.3 Using the nuts on the studs, replace the packing and the gland. Reinstall the remaining cap screws (4) and reattempt seat shut-off.
- B-5.10 When trapped pressure has been reduced to zero remove:
 - B-5.10.1 The two nuts and the gland (5).
 - B-5.10.2 Upper thrust washer (7) may remain in gland (5) or on stem square (11), top packing adapter (8), V-rings (9), and lower packing adapter (10).
- B-5.11 Lubricate new parts with light oil and insert in packing chamber as follows: Lower packing adapter (10), V-rings (9), and top packing adapter (8).
- B-5.12 Place upper thrust washer (7) on stem square (11) if removed.
- B-5.13 Position gasket (6) and gland (5) on cover. Insert cap screws (4) fully and tighten.
- B-5.14 Place operating square (3) and lock washer (2) on stem, secure with nut (1).
- B-5.15 If gland and packing do not rise as nuts are loosened, continue to loosen nuts until the top of the nuts are flush with the top of the all thread studs.
 - B-5.15.1 Slowly rotate the stem square (11) in the same direction as closing the valve until the trapped pressure begins to bleed.
 - B-5.15.2 If the bleeding pressure does not diminish, successful seat shut-off has not been obtained. Rotate stem in the direction for opening valve until it contacts lower thrust washer.

Take care not to break gate seal as packing will be subject to full pressure and gas flow.

UNCONTROLLED IF PRINTED

- B-5.16 Retighten nuts on all thread studs and reinstall cap screws (4) in gland.
- B-5.17 Reattempt seat shut off.
- B-5.18 When trapped pressure has been reduced to zero, remove the two nuts and then gland (5).
- B-5.19 Rotate stem square (11) in the same direction as closing the valve until it is free from the wedge.
- B-5.20 Withdraw stem from valve.
 - B-5.20.1 Lower thrust washer (13) may remain in the cover or on the stem square (11).
- B-5.21 Remove top packing adapter (8), V-rings (9), and lower packing adapter (10).
- B-5.22 Replace lower thrust washer (13) in cover (if removed).
- B-5.23 Lubricate new parts with light oil and insert in packing chamber as follows:
 - B-5.23.1 Lower packing adapter (10).
 - B-5.23.2 V-rings (9).
 - B-5.23.3 Top packing adapter (8).
- B-5.24 Insert stem square (11) in cover and rotate slowly by hand in the direction for opening the valve.
- B-5.25 Continue rotation until stem shoulder (12) contacts lower thrust washer (13).

Additional stem rotation will unseat the wedge resulting in full gas pressure and flow.

- B-5.26 Check if upper thrust washer (7) is in place.
 - B-5.27 Position gasket (6) and gland (5) on cover.
 - B-5.28 Insert cap screws (4) fully and tighten.
 - B-5.29 Place operating square (3) and lock washer (2) on stem and then secure with nut (1).
- B-6. Bonnet Leak Repair
- B-6.1 When a bonnet leak is detected, do not attempt to retighten the existing bonnet bolts, and do not attempt to operate the valve, since loads applied could cause damaged bolts to break.
 - B-6.2 Refer to [VALV 4](#) Forms and Reference Materials, for Kerotest Model -1 Gate Valve Bonnet Leak Repair Procedure document.
 - B-6.3 If the valve can be depressurized, remove bonnet and replace gasket and existing bonnet bolts after depressurization with only Kerotest authorized parts.
 - B-6.3.1 Coat the new bonnet gasket with Slic-Tite TFE paste or equivalent.
 - B-6.3.2 During the bolt replacement, tighten bolts in proper sequence and to the torque listed in manufacturer's instructions.

UNCONTROLLED IF PRINTED

B-6.4 If the valve cannot be depressurized, remove and replace the bolts one at a time.

B-6.4.1 For 1-1/4" valve, a special Kerotest bolt replacement fixture and procedure must be used. Refer to VALV 4 for Kerotest manufacturer repair manual.

B-6.4.2 For 2" thru 6" valve, Kerotest strongly recommends that support clamps be used during bolt replacement. See [Figure B3](#).

1. Part number for Support Clamps for 2" and 3" valves is 72544794.
2. Part number for Support Clamps for 4" and 6" valves is 72544802.

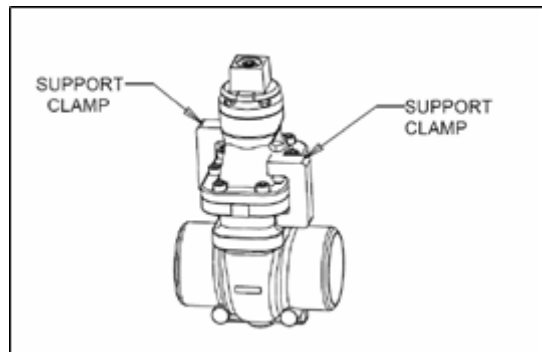

Figure B3 Kerotest Valve Support Clamp

B-6.4.3 Support clamps are not required on 8" and larger valves.

B-6.5 If leakage continues on valves 2 inch and larger after bolts have been replaced, contact Kerotest or a Kerotest vendor. A Kerotest Factory Trained person is the only one qualified to perform the necessary repair procedures.

Appendix C - Balon Flanged Ball Valve Repair

C-1. General

C-1.1 This section provides information extracted from Balon installation and repair manual for the repair of Balon flanged body Series F steel ball valves.

C-2. Repair Kit

C-2.1 Balon valves require no regular maintenance to maintain proper operation and sealing. Balon stems require no adjustment or greasing for proper sealing and operation.

**SERIES "F" AND "S" FLANGED END AND SCREWED END
(LEVER OPERATED AND GEAR OPERATED) SERIES "LM"
AND "LS" SCREWED END**

SEAL KIT CONTENTS: SERIES "F" AND "S" LEVER OPERATED

1. Seal kits are available for Balon Series "F" and "S" ball valves. Each kit contains the following parts:
 - A. 2 - Ball Seats
 - B. 1 - Body O-Ring
 - C. 1 - Stem TFE Thrust Washer
 - D. 1 - Stem O-Ring
 - E. 1 - Stem Stop Plate Retainer Ring
 - F. 1 - Stem Weather Guard
 - G. 1 - Dust Cover
 - H. 1 - Stop Plate Retainer
 - I. 1 - Stop Plate

SEAL KIT CONTENTS: SERIES "F" GEAR OPERATED

1. Seal kits are available for Balon Series "F" Flanged End Gear Operated ball valves. Each kit contains the following parts:
 - A. 2 - Ball Seats
 - B. 1 - Body O-Ring
 - C. 1 - Stem TFE Thrust Washer
 - D. 1 - Stem O-Ring
 - E. 1 - Stem Stop Plate Retainer Ring
 - G. 1 - Stem Key

SEAL KIT CONTENTS: SERIES "LM" AND "LS"

1. Seal kits are available for Balon Series "LM" and "LS" ball valves. Each kit contains the following parts:
 - A. 2 - Ball Seats
 - B. 1 - Weather Guard
 - C. 1 - Stem Washer
 - D. 1 - Stem Seal
 - E. 1 - Body Seal

Seal kits are sold by valve ball bore size and will fit any Balon ball valve with that bore size, regardless of valve material, end style, or working pressure. (Must specify NACE seal kit if valve has NACE trim. The valve will have letter N in valve part number tag, such as 2R-F63N-RF.) Otherwise, order standard seal kit. If letters TFE appear on valve tag, order Teflon seats.

C-3. Parts List

**BALON BALL VALVE PARTS LIST
SERIES "F" AND "S"
(LEVER OPERATED)**

ITEM	PART NAME
1	Handle
2	Handle Bolt
3	Weather Guard
4	Lock Plate Retainer
5	Lock Plate
6	Dust Cover
7	Stop Plate Retainer
8	Stop Plate
9	Stem O-Ring
10	Stem Seal
11	Stem
12	Ball
13	Ball Seat
14	Body O-Ring
15	End Adapter
16	Body
17	Body Stud Nuts
18	Body Stud Bolts
19	Body Bolts

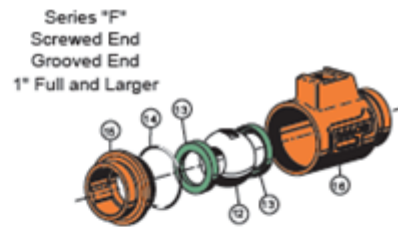
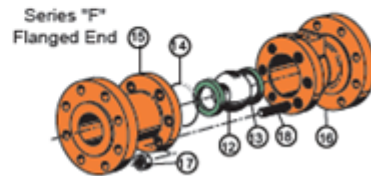
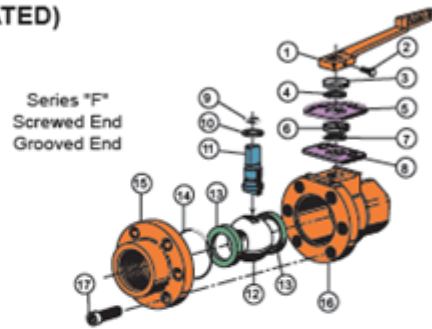

BALON BALL VALVES HAVE A BODY SECTION WHICH CONTAINS THE BALL AND STEM AND THE ADAPTER SECTION THAT BOLTS OR SCREWS TO THE BODY.

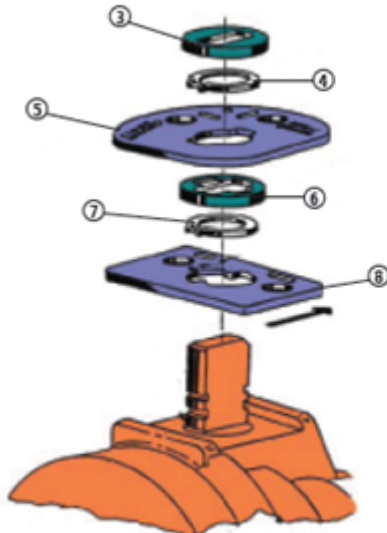

WITH SAFETY LOCK DEVICE
FIGURE 1

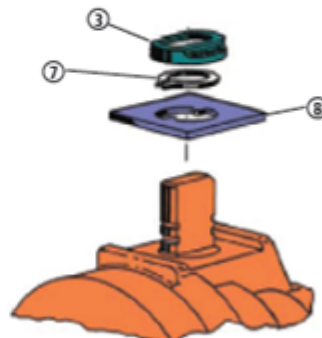

WITHOUT SAFETY LOCK DEVICE
FIGURE 1

WARNING: BEFORE ATTEMPTING TO REPAIR A VALVE THAT HAS BEEN IN SERVICE BE SURE TO BLOCK THE ENDS AND SLOWLY OPEN AND CLOSE THE VALVE TO VENT ANY INTERNAL PRESSURE

C-4. Repair Procedures

**BALON BALL VALVE REPAIR
SERIES "F" AND "S" (LEVER
OPERATED)**

1. **WARNING: BEFORE ATTEMPTING TO REPAIR A VALVE THAT HAS BEEN IN SERVICE BE SURE TO BLOCK THE ENDS AND SLOWLY OPEN AND CLOSE THE VALVE TO VENT ANY INTERNAL PRESSURE.**
2. Disassemble valve body and adapter.
3. With valve in closed position remove ball seat (13), body O-Ring (14), and ball (12).
4. Remove stem top works. (Note position of all components.)
5. Before removing stem, carefully file all edges of stem wrench flats and stop plate area to remove any burrs or permanent damage may occur to the stem bore. (FIG. 1)
6. Remove stem (11), stem O-Ring (9), and stem washer (10).
7. Clean all valve components thoroughly.
8. Install new stem seals (9) and (10) and grease.
9. Install stem (11) in valve. Install stop plate (8) and stop plate retainer (7) and fill cavity around stem with grease. **(IF VALVE IS NOT EQUIPPED WITH STANDARD SAFETY LOCK DEVICE (FIG. 2) SKIP TO STEP 10.)** Install dust cover (6). Install lock plate (5). Check for proper alignment, one hole and one slot on lock plate should line up with one hole and one slot on stop plate when fully open or closed. Install lock plate retainer (4). Grease snap ring area and install weather guard (3).
10. Install new ball seats (13) and body O-Ring (14), and grease.
11. Install ball (12).
12. Assemble valve. When installing body to end adapter, be careful not to pinch or damage O-Ring.
13. After valve is assembled, cycle to assure free and easy operation.

**SYNTHETIC GREASE THAT IS MOISTURE RESISTANT SHOULD BE USED.
IF ANY PROBLEMS ARE ENCOUNTERED, CONTACT BALON CORPORATION AT 405-677-3321.**

VALVES

October 1, 2022

VALV 3 Approved Valves and Valve Box Accessories**1.0 Purpose**

The procedure provides lists of Ameren Illinois (AIC) approved valves and accessories.

2.0 Scope

This document addresses the following:

[3.0 Target Audience](#)[4.0 Plastic \(PE\) Ball Valves](#)[5.0 Steel Ball Valves](#)[6.0 Kerotest Gate Valves](#)[7.0 Valve Box Accessories Valve Box Accessories Stock Code Table](#)**3.0 Target Audience**

- Gas Engineer
- Gas Supervisors
- Gas Field Personnel
- Gas Tech Engineering (GTE)
- Gas Tech Services (GTS) Supervisors
- Gas Tech Service (GTS) Personnel
- Gas Storage Engineering (GSE)
- Gas Storage Supervisors
- Gas Storage Field Operators

4.0 Plastic (PE) Ball Valves**4.1 General**

- 4.1.1 This section provides AIC stock codes along with manufacturer's specifications for plastic ball valves installed on plastic high pressure distribution, plastic distribution and plastic service lines.
- 4.1.2 Kerotest, Lyall - Polytec, and Broen are approved manufacturers for all polyethylene ball valves.
- 4.1.3 Refer to the valve manufacturer's website for product specifications on valve dimensions.
- 4.1.4 PE2406/PE2708 Ball Valve Stock Codes – Table 1

STOCK #	SIZE	MATERIAL	TYPE	CONNECTION	RATING	Valve Box
39 22 116	1/2"	PE2406 PE2708	Full Port Ball	Butt Fusion	60 PSIG	19 72 128
39 22 121	1"	PE2406 PE2708	Full Port Ball	Butt Fusion	60 PSIG	19 72 128
62 05 075	1 1/4"	PE2406 PE2708	Reduced Port Ball	Butt Fusion	60 PSIG	19 72 128
19 17 224	2"	PE2406 PE2708	Full Port Ball	Butt Fusion	60 PSIG	19 72 129*

UNCONTROLLED IF PRINTED

39 10 383	4"	PE2406 PE2708	Full Port Ball	Butt Fusion	60 PSIG	19 72 130
39 10 552	6"	PE2406 PE2708	Full Port Ball	Butt Fusion	60 PSIG	19 72 131
39 10 722	8"	PE2406 PE2708	Full Port Ball	Butt Fusion	60 PSIG	19 72 132
* Support included						

4.1.5 PE3408/PE4710 Ball Valve Stock Codes – Table 2

STOCK #	SIZE	MATERIAL	TYPE	CONNECTION	RATING	Valve Box
39 22 630	1/2"	PE3408 PE4710	Full Port Ball	Butt Fusion	125 PSIG	19 72 128
39 22 549	1"	PE3408 PE4710	Full Port Ball	Butt Fusion	125 PSIG	19 72 128
39 22 548	2"	PE3408 PE4710	Full Port Ball	Butt Fusion	125 PSIG	19 72 129*
39 42 661	4"	PE3408 PE4710	Full Port Ball	Butt Fusion	125 PSIG	19 72 130
39 42 660	6"	PE3408 PE4710	Full Port Ball	Butt Fusion	125 PSIG	19 72 131
39 22 640	8"	PE3408 PE4710	Full Port Ball	Butt Fusion	125 PSIG	19 72 132
39 22 636	12"	PE3408 PE4710	Full Port Ball	Butt Fusion	125 PSIG	N/A
* Support included						

5.0 Steel Ball Valves

5.1 General

- 5.1.1 This section provides AIC stock codes along with manufacturer's specifications for steel ball valves being installed within AIC's transmission, steel distribution systems and steel service lines.
- 5.1.2 Balon (Utili Seal), Kerotest (Weldball), and Broen (Ballomax) are approved manufacturers for floating ball valves.
- 5.1.3 Cameron and Balon are approved manufacturers for bolted trunnion mounted ball valves.
- 5.1.4 Used as an alternate for a Kerotest Model 1 Gate Valve
- 5.1.5 Buried or above ground applications
- 5.1.6 Refer to the valve manufacturer's website for product specifications on valve dimensions.

1. Valves manufactured prior to July 2006 have the following ANSI rating: Class 150 - 275 psig and Class 300 - 720 psig.
2. Valve manufactured after July 2006 have the following ANSI rating: Class 150 - 285 psig and Class 300 - 740 psig.
3. If in question, check the pressure rating on the valve body.

5.2 Class 150 Steel Ball Valves and associated valve box - Table 3

Table 3: Steel Ball Valves, Class 150						
STOCK CODE	SIZE	MATERIAL	TYPE	CONNECTION	RATING	Valve Box
39 22 285	1-1/4"	Steel	Reduced Port	Weld	285 PSIG	19 72 129
39 22 236	2"	Steel	Full Port Ball	Weld	285 PSIG	19 72 129
39 22 324	3"	Steel	Full Port Ball	Weld	285 PSIG	19 72 130
39 22 237	4"	Steel	Full Port Ball	Weld	285 PSIG	19 72 130
39 22 591	10"	Steel	Full Port Ball	Weld	285 PSIG	N/A
39 22 594	12"	Steel	Full Port Ball	Weld	285 PSIG	N/A
39 22 596	14"	Steel	Full Port Ball	Weld	285 PSIG	N/A
39 22 565	16"	Steel	Full Port Ball	Weld	285 PSIG	N/A
39 22 564	18"	Steel	Full Port Ball	Weld	285 PSIG	N/A
39 22 297	2"	Steel	Full Port Ball	Flange	285 PSIG	19 72 129
39 22 610	10"	Steel	Full Port Ball	Flange	285 PSIG	N/A
39 22 611	12"	Steel	Full Port Ball	Flange	285 PSIG	N/A
39 22 625	14"	Steel	Full Port Ball	Flange	285 PSIG	N/A
39 22 628	16"	Steel	Full Port Ball	Flange	285 PSIG	N/A
39 22 619	18"	Steel	Full Port Ball	Flange	285 PSIG	N/A
39 22 543	2"	Steel	Full Port	Weld x Flange	285 PSIG	19 72 129
39 22 544	4"	Steel	Full Port	Weld x Flange	285 PSIG	19 72 130
39 22 572	10"	Steel	Full Port Ball	Weld x Flange	285 PSIG	N/A
39 22 573	12"	Steel	Full Port Ball	Weld x Flange	285 PSIG	N/A
39 22 578	14"	Steel	Full Port Ball	Weld x Flange	285 PSIG	N/A
39 22 581	16"	Steel	Full Port Ball	Weld x Flange	285 PSIG	N/A
39 22 585	18"	Steel	Full Port Ball	Weld x Flange	285 PSIG	N/A

5.3 Class 300 Steel Ball Valves and associated valve box - Table 4

Table 4: Steel Ball Valves, Class 300						
STOCK CODE	SIZE	MATERIAL	TYPE	CONNECTION	RATING	Valve Box
39 22 546	3/4"	Steel	Reduced Port Ball	Weld	740 PSIG	19 72 128
39 22 547	1"	Steel	Reduced Port Ball	Weld	740 PSIG	19 72 128
39 22 325	2"	Steel	Full Port Ball	Weld	740 PSIG	19 72 129
39 22 326	3"	Steel	Full Port Ball	Weld	740 PSIG	19 72 130
39 22 327	4"	Steel	Full Port Ball	Weld	740 PSIG	19 72 130

UNCONTROLLED IF PRINTED

39 22 584	6"	Steel	Full Port Ball	Weld	740 PSIG	19 72 132
39 22 590	8"	Steel	Full Port Ball	Weld	740 PSIG	N/A
39 22 589	10"	Steel	Full Port Ball	Weld	740 PSIG	N/A
39 22 593	12"	Steel	Full Port Ball	Weld	740 PSIG	N/A
39 22 595	14"	Steel	Full Port Ball	Weld	740 PSIG	N/A
39 22 562	18"	Steel	Full Port Ball	Weld	740 PSIG	N/A
39 22 561	20"	Steel	Full Port Ball	Weld	740 PSIG	N/A
39 22 598	24"	Steel	Full Port Ball	Weld	740 PSIG	N/A
39 22 604	6"	Steel	Full Port Ball	Flange	740 PSIG	19 72 132
39 22 606	8"	Steel	Full Port Ball	Flange	740 PSIG	N/A
39 22 609	10"	Steel	Full Port Ball	Flange	740 PSIG	N/A
39 22 614	12"	Steel	Full Port Ball	Flange	740 PSIG	N/A
39 22 615	14"	Steel	Full Port Ball	Flange	740 PSIG	N/A
39 22 617	16"	Steel	Full Port Ball	Flange	740 PSIG	N/A
39 22 629	18"	Steel	Full Port Ball	Flange	740 PSIG	N/A
39 22 621	20"	Steel	Full Port Ball	Flange	740 PSIG	N/A
39 22 622	24"	Steel	Full Port Ball	Flange	740 PSIG	N/A
39 22 294	2"	Steel	Full Port Ball	Weld x Flange	740 PSIG	19 72 129
39 22 295	4"	Steel	Full Port Ball	Weld x Flange	740 PSIG	19 72 130
39 22 570	8"	Steel	Full Port Ball	Weld x Flange	740 PSIG	N/A
39 22 571	10"	Steel	Full Port Ball	Weld x Flange	740 PSIG	N/A
39 22 576	12"	Steel	Full Port Ball	Weld x Flange	740 PSIG	N/A
39 22 577	14"	Steel	Full Port Ball	Weld x Flange	740 PSIG	N/A
39 22 580	16"	Steel	Full Port Ball	Weld x Flange	740 PSIG	N/A
39 22 583	18"	Steel	Full Port Ball	Weld x Flange	740 PSIG	N/A
39 22 587	20"	Steel	Full Port Ball	Weld x Flange	740 PSIG	N/A
39 22 588	24"	Steel	Full Port Ball	Weld x Flange	740 PSIG	N/A

5.4 Class 150 Cameron and Balon Trunnion Mounted Ball Valves - Table 5

Table 5: Trunnion Mounted Ball Valves, Class 150					
STOCK CODE	SIZE	MATERIAL	TYPE	CONNECTION	RATING
39 22 591*	10"	Steel	Full Port Ball	Weld	285 PSIG
39 22 594*	12"	Steel	Full Port Ball	Weld	285 PSIG
39 22 596	14"	Steel	Full Port Ball	Weld	285 PSIG
39 22 565	16"	Steel	Full Port Ball	Weld	285 PSIG
39 22 564	18"	Steel	Full Port Ball	Weld	285 PSIG
39 22 610*	10"	Steel	Full Port Ball	Flanged	285 PSIG
39 22 611*	12"	Steel	Full Port Ball	Flanged	285 PSIG
39 22 625	14"	Steel	Full Port Ball	Flanged	285 PSIG
39 22 628	16"	Steel	Full Port Ball	Flanged	285 PSIG
39 22 619	18"	Steel	Full Port Ball	Flanged	285 PSIG

UNCONTROLLED IF PRINTED

39 22 572*	10"	Steel	Full Port Ball	Weld x Flange	285 PSIG
39 22 573*	12"	Steel	Full Port Ball	Weld x Flange	285 PSIG
39 22 578	14"	Steel	Full Port Ball	Weld x Flange	285 PSIG
39 22 581	16"	Steel	Full Port Ball	Weld x Flange	285 PSIG
39 22 585	18"	Steel	Full Port Ball	Weld x Flange	285 PSIG
* Also manufactured by Balon					

5.5 Class 300 Cameron and Balon Trunnion Mounted Ball Valves - Table 6

Table 6: Trunnion Mounted Ball Valves, Class 300					
STOCK CODE	SIZE	MATERIAL	TYPE	CONNECTION	RATING
39 22 590*	8"	Steel	Full Port Ball	Weld	740 PSIG
39 22 589*	10"	Steel	Full Port Ball	Weld	740 PSIG
39 22 593*	12"	Steel	Full Port Ball	Weld	740 PSIG
39 22 595	14"	Steel	Full Port Ball	Weld	740 PSIG
39 22 562	18"	Steel	Full Port Ball	Weld	740 PSIG
39 22 561	20"	Steel	Full Port Ball	Weld	740 PSIG
39 22 598	24"	Steel	Full Port Ball	Weld	740 PSIG
39 22 604	6"	Steel	Full Port Ball	Flanged	740 PSIG
39 22 606*	8"	Steel	Full Port Ball	Flanged	740 PSIG
39 22 609*	10"	Steel	Full Port Ball	Flanged	740 PSIG
39 22 614*	12"	Steel	Full Port Ball	Flanged	740 PSIG
39 22 615	14"	Steel	Full Port Ball	Flanged	740 PSIG
39 22 617	16"	Steel	Full Port Ball	Flanged	740 PSIG
39 22 629	18"	Steel	Full Port Ball	Flanged	740 PSIG
39 22 621	20"	Steel	Full Port Ball	Flanged	740 PSIG
39 22 622	24"	Steel	Full Port Ball	Flanged	740 PSIG
39 22 570*	8"	Steel	Full Port Ball	Weld x Flange	740 PSIG
39 22 571*	10"	Steel	Full Port Ball	Weld x Flange	740 PSIG
39 22 576*	12"	Steel	Full Port Ball	Weld x Flange	740 PSIG
39 22 577	14"	Steel	Full Port Ball	Weld x Flange	740 PSIG
39 22 580	16"	Steel	Full Port Ball	Weld x Flange	740 PSIG
39 22 583	18"	Steel	Full Port Ball	Weld x Flange	740 PSIG
39 22 587	20"	Steel	Full Port Ball	Weld x Flange	740 PSIG
39 22 588	24"	Steel	Full Port Ball	Weld x Flange	740 PSIG
* Also manufactured by Balon					

6.0 Kerotest Gate Valves

6.1 General

6.1.1 This section provides AIC stock codes for steel gate valves being installed on transmission, high pressure distribution, steel distribution, and steel service lines.

UNCONTROLLED IF PRINTED

1. Valves manufactured prior to July 2006 have the following ANSI rating: Class 150 – 275 psig and Class 300 – 720 psig.
2. Valve manufactured after July 2006 have the following ANSI rating: Class 150 – 285 psig and Class 300 – 740 psig.
3. If in question, check the pressure rating on the valve body.

6.1.2 Refer to the valve manufacturer's website for product specifications on valve dimensions.

6.2 Class 150 Kerotest Gate Valve Stock Codes – Table 7

Table 7: Kerotest Gate Valves, Class 150						
STOCK #	SIZE	MATERIAL	TYPE	CONNECTION	RATING	Valve Box
39 22 176	4"	Steel	Gate	Weld	285 PSIG	1972132
39 22 183	6"	Steel	Gate	Weld	285 PSIG	1972132
39 22 354	2"	Steel	Gate	Flanged	285 PSIG	1972129
39 22 364	3"	Steel	Gate	Flanged	285 PSIG	1972132
39 10 432	4"	Steel	Gate	Flanged	285 PSIG	1972132
39 10 426	6"	Steel	Gate	Flanged	285 PSIG	1972132
39 22 005	2"	Steel	Gate	Weld x Flange	285 PSIG	1972129
39 22 008	3"	Steel	Gate	Weld x Flange	285 PSIG	1972132
39 22 010	4"	Steel	Gate	Weld x Flange	285 PSIG	1972132

6.3 Class 300 Kerotest Gate Valve Stock Codes – Table 8

Table 8: Kerotest Gate Valves, Class 300						
STOCK #	SIZE	MATERIAL	TYPE	CONNECTION	RATING	Valve Box
39 22 153	1-1/4"	Steel	Gate	Weld	740 PSIG	1972129
39 10 428	2"	Steel	Gate	Weld	740 PSIG	1972129
39 22 360	3"	Steel	Gate	Weld	740 PSIG	1972132
39 22 092	4"	Steel	Gate	Weld	740 PSIG	1972132
39 22 387	6"	Steel	Gate	Weld	740 PSIG	1972132
39 22 392	8"	Steel	Gate	Weld	740 PSIG	1972132
39 22 199	10"	Steel	Gate	Weld	740 PSIG	1972132
39 22 200	12"	Steel	Gate	Weld	740 PSIG	1972132
39 22 353	2"	Steel	Gate	Flanged	740 PSIG	1972129
39 22 386	6"	Steel	Gate	Flanged	740 PSIG	1972132
39 22 006	2"	Steel	Gate	Weld x Flange	740 PSIG	1972129
39 22 363	3"	Steel	Gate	Weld x Flange	740 PSIG	1972132
39 22 011	4"	Steel	Gate	Weld x Flange	740 PSIG	1972132
39 22 386	6"	Steel	Gate	Weld x Flange	740 PSIG	1972132
39 22 391	8"	Steel	Gate	Weld x Flange	740 PSIG	1972132

7.0 Valve Box Accessories Stock Code Table

UNCONTROLLED IF PRINTED

Table 9 - Valve Box Accessories Stock Codes	
STOCK #	DESCRIPTION
19 72 133	Extension for threaded valve box with 5 1/4" shaft
19 72 135	Extension for threaded valve box with 2 1/2" shaft
49 62 028	18" extension for Handley sliding valve box
19 62 620	1" paving extension for threaded valve box with 5 1/4" shaft
19 62 489	2" paving extension for threaded valve box with 5 1/4" shaft
19 62 490	3" paving extension for threaded valve box with 5 1/4" shaft
21 96 136	Replacement penta head bolt for Handley valve box lid
19 72 144	Replacement 16" top section for threaded valve box with 5 1/4" shaft - includes cast iron ring
19 72 145	Replacement 27" top section for threaded valve box with 5 1/4" shaft - includes cast iron ring
19 72 138	Replacement cast iron lid for threaded valve box with 5 1/4" shaft
19 72 148	Replacement top section for service size Handley sliding valve box
19 72 149	Replacement lid for service size Handley sliding valve box
19 72 150	Replacement top section for Handley sliding valve box for 1 1/4" and larger valves
19 72 151	Replacement lid for Handley sliding valve box for 2" and larger steel valves
19 72 152	Replacement lid for Handley sliding valve box for 2" and larger plastic valves

End of Instructions.

Operator Qualification (OQ) Required?

NO.

Appendices

NONE.

Attachments

NONE.

Compliance Requirements

NONE.

Reference Documents

NONE.

Document Rescission

VALV 3.3 Valves: Approved Valves and Valve Box Accessories, May 15, 2022

Revision Notes

Location of Changes	Summary of Changes
Throughout this document	All of the valve dimension tables have been removed. Manufacturers change some dimension with each update making it difficult to ensure our tables had accurate information. Best solution is to uti-

UNCONTROLLED IF PRINTED

	lize manufacturer's website for the latest information and dimensions.
Paragraph 4.1.1 – PE Ball Valves	Removed reference to dimensions.
Paragraph 4.1.3 -	Retitled - PE2406/PE2708 Ball Valve Stock Code – Table 1
Paragraph 4.1.3 – Table 1	Added 1-1/4" Reduced Port Ball Valve
Paragraph 4.1.4	Retitled – PE3408/PE4710 Ball Valve Stock Code – Table 2
Paragraph 4.1.4 – Table 2	Added – 1/2", 8" and 12" Full Port Ball Valves
Paragraph 5.1.1 – Steel Ball Valves	Removed reference to dimensions
Paragraph 5.1.2	Balon, Kerotest, and Broen are approved manufacturers for floating ball valves.
Paragraph 5.1.3	Cameron and Balon are approved manufacturers for bolted trunnion mounted ball valves.
Subsection 5.2 – Class 150 Steel Ball Valves	Added several new Class 150 valves in Table 3.
Subsection 5.3 – Class 300 Steel Ball Valves	Added several new Class 300 valves in Table 4.
Subsection 5.4 – Class 150 Trunnion Mounted Ball Valves	Table 5 – Class 150 Cameron and Balon Trunnion Mounted Ball Valves have been added.
Subsection 5.5 - Class 300 Trunnion Mounted Ball Valves	Table 6 - Class 300 Cameron and Balon Trunnion Mounted Ball Valves have been added
Paragraph 6.1.1 – Kerotest Gate Valve	Removed reference to dimensions
Subsection 6.2 - Class 150 Kerotest Gate Valve	Several new valves have been added to Table 7. Table 7 now contains all of the connection configurations that were previously in separate tables,
Subsection 6.3 - Class 300 Kerotest Gate Valve	Several new valves have been added to Table 8. Table 8 now contains all of the connection configurations that were previously in separate tables,

UNCONTROLLED IF PRINTED

VALVES

October 1, 2020

VALV 4 Forms and Reference Materials

Click on the links below to open the documents.

References

1. [Kerotest Model M-1 Gate Valve Operations Manual](#)
2. [Kerotest Model -1 Gate Valve Bonnet Leak Repair Procedure](#)
3. [Balon Installation and Repair Manual](#)
4. [Sealweld Handbook of Valve Lubrication and Maintenance](#)
5. [Cameron Type 31 Installation, Operation and Maintenance Manual](#)
6. [Grove B5, 4B, 4C Installation and Maintenance Manual](#)
7. [Cameron B5 Ball Valves Instruction and Maintenance Manual](#)
8. [QS-2000A Operations and Maintenance Manual](#)

End of Section.

Document Rescission

VALV 4 Valves: Forms and Reference Materials, April 1, 2020.

Revision Notes

Location of Changes	Summary of Changes
Not applicable.	This is a new document.

WELD-Welding

WELDING

October 1, 2020

WELD 0 Table of Contents

WELD 1 Welding: Requirements

Section 1.0 Purpose

Section 2.0 Scope

Section 3.0 Target Audience

Section 4.0 General

Section 5.0 Welding Procedures

Section 6.0 Qualification of Welders

Section 7.0 Limitations on Welders

Section 8.0 Preparation for Welding

Section 9.0 Inspection and Test of Welds

Section 10.0 Nondestructive Testing

Section 11.0 Repair or Removal of Defects

Section 12.0 Production Weld Quality Issues

Operator Qualification (OQ)

Appendices

Appendix A - Flow Chart for Production Weld Quality Issues

Compliance Requirements

Reference Documents

Document Rescission

WELD 2.1 Welding: Safe Welding Practices

Section 1.0 Purpose

Section 2.0 Scope

Section 3.0 Target Audience

Section 4.0 Activity Areas

Section 5.0 Fire Guard

Section 6.0 Supervisor Role

Section 7.0 Welder Responsibilities

Section 8.0 Welding or Cutting on Containers

UNCONTROLLED IF PRINTED

Section 9.0 Protection of Personnel

Section 10.0 Ventilation

Section 11.0 Equipment

Operator Qualification (OQ)

Compliance Requirements

Reference Documents

Document Rescission

WELD 2.2 Welding: Welder Qualifications

Section 1.0 Purpose

Section 2.0 Scope

Section 3.0 Target Audience

Section 4.0 General

Section 5.0 Welding Inspector

Section 6.0 Qualification Categories - Initial Test

Section 7.0 Service Line Connection Welding (Service Tee)

Section 8.0 Workmanship

Section 9.0 Welder Requalification

Section 10.0 Destructive Testing

Section 11.0 ASME Piping

Section 12.0 Records and Retention (§192.227)

Operator Qualification (OQ)

Appendices

Appendix A - Welder Positions

Compliance Requirements

Reference Documents

Document Rescission

WELD 2.3 Welding: Construction of Pipelines

Section 1.0 Purpose

Section 2.0 Scope

Section 3.0 Target Audience

Section 4.0 Material Requirements

Section 5.0 Welding Procedures

Section 6.0 Welder Qualification

Section 7.0 Welding Process

Section 8.0 Pre-alignment Inspection

UNCONTROLLED IF PRINTED

Section 9.0 Welding Requirements

Section 10.0 Weld Repairs

Section 11.0 Weld Inspection

Section 12.0 Records

Operator Qualification (OQ)

Appendices

Appendix A - Joining Unequal Steel Wall Pipe and Fittings

Compliance Requirements

Reference Documents

Document Rescission

WELD 2.4 Welding: In-Service Welding

Section 1.0 Purpose

Section 2.0 Scope

Section 3.0 Target Audience

Section 4.0 General

Section 5.0 Material Requirements

Section 6.0 Acceptable Repair Methods

Section 7.0 Welder Qualification

Section 8.0 Welding Procedures

Operator Qualification (OQ)

Compliance Requirements

Reference Documents

Document Rescission

WELD 2.5 Welding: Visual Inspection

Section 1.0 Purpose

Section 2.0 Scope

Section 3.0 Target Audience

Section 4.0 Inspection Requirements

Section 5.0 Records/Reports

Section 6.0 Inspection Equipment and References

Operator Qualification (OQ)

Compliance Requirements

Reference Documents

Document Rescission

WELD 2.6 Welding: Radiographic Testing

- Section 1.0 Purpose
- Section 2.0 Scope
- Section 3.0 Target Audience
- Section 4.0 General
- Section 5.0 Radiographic Testing Personnel
- Section 6.0 Radiation Safety
- Section 7.0 Radiographic Testing Procedures
- Section 8.0 Radiographic Quality
- Section 9.0 Production Radiography
- Section 10.0 Reports
- Operator Qualification (OQ)
- Compliance Requirements
- Reference Documents
- Document Rescission

WELD 2.7 Welding: Magnetic Particle Testing

- Section 1.0 Purpose
- Section 2.0 Scope
- Section 3.0 Target Audience
- Section 4.0 General
- Section 5.0 Magnetic Particle Testing Personnel
- Section 6.0 Magnetic Particle Testing Procedures
- Section 7.0 Method and Equipment
- Section 8.0 Dry Magnetic Particle Application
- Section 9.0 Wet Magnetic Particle Application
- Section 10.0 Interpretation and Acceptance
- Section 11.0 Reports
- Section 12.0 Report Retention
- Operator Qualification (OQ)
- Compliance Requirements
- Reference Documents
- Document Rescission

WELD 2.8 Welding: Liquid Penetrant Testing

- Section 1.0 Purpose

- Section 2.0 Scope
- Section 3.0 Target Audience
- Section 4.0 General
- Section 5.0 Liquid Penetrant Testing Personnel
- Section 6.0 Liquid Penetrant Testing Procedures
- Section 7.0 Method and Equipment
- Section 8.0 Procedure
- Section 9.0 Interpretation and Acceptance
- Section 10.0 Reports
- Section 11.0 Report Retention
- Operator Qualification (OQ)
- Compliance Requirements
- Reference Documents
- Document Rescission

WELD 2.9 Welding: Ultrasonic Thickness Examination

- Section 1.0 Purpose
- Section 2.0 Scope
- Section 3.0 Target Audience
- Section 4.0 Equipment and Materials
- Section 5.0 Personnel Requirements
- Section 6.0 Instrument Calibration
- Section 7.0 Technique
- Section 8.0 Final Cleaning
- Section 9.0 Records
- Operator Qualification (OQ)
- Appendices
 - Appendix A - Ultrasonic Thickness Record Form
- Compliance Requirements
- Reference Documents
- Document Rescission

WELD 2.10 Welding: Arc Burn Removal

- Section 1.0 Purpose
- Section 2.0 Scope
- Section 3.0 Target Audience
- Section 4.0 General

Section 5.0 Removal Sequence

Section 6.0 API Wall Thickness Tolerances

Operator Qualification (OQ)

Appendices

Appendix A - API Table 9, 43rd Edition

Appendix B - API Table 11, 45th Edition

Compliance Requirements

Reference Documents

Document Rescission

WELD 3 Welding: Useful Information

Section 1.0 Purpose

Section 2.0 Scope

Section 3.0 Target Audience

Section 4.0 Electrode Properties

Section 5.0 Pipe Properties API 5L

Section 6.0 Useful Formulas

Section 7.0 Decimal Equivalents

Section 8.0 Welder Identification System

Section 9.0 Copper Weld Cable Size

Operator Qualification (OQ)

Compliance Requirements

Reference Documents

Document Rescission

WELD 4 Welding: Forms and Reference Materials

Forms

References

Document Rescission

End Table of Contents.

Document Rescission

WELD 0 Welding Table of Contents, October 1, 2019.

Revision Notes

Location of Changes	Summary of Changes
Not applicable.	This is a new document.

UNCONTROLLED IF PRINTED

WELDING

December 1, 2020

WELD 1 Requirements**1.0 Purpose**

This document includes the welding specifications and procedures to be used for construction, fabrication, and maintenance of all Ameren Illinois (AIC) gas piping systems. Coverage shall be fully in accordance with 49 CFR Part 192 Subpart E - Welding of Steel in Pipelines.

2.0 Scope

This document addresses the following:

[3.0 Target Audience](#)**[4.0 General](#)****[5.0 Welding Procedures](#)****[6.0 Qualification of Welders](#)****[7.0 Limitations on Welders](#)****[8.0 Preparation for Welding](#)****[9.0 Inspection and Test of Welds](#)****[10.0 Nondestructive Testing](#)****[11.0 Repair or Removal of Defects](#)****[12.0 Production Weld Quality Issues](#)**

Appendices

[Appendix A - Flow Chart for Production Weld Quality Issues](#)**3.0 Target Audience**

- Gas Tech Engineering (GTE)
- Gas Integrity Management Personnel
- Gas Engineers
- Gas Superintendents
- Gas Supervisors
- Gas Field Personnel - Welders
- Gas Construction Services Superintendents
- Gas Construction Services Supervisors
- Gas Contract Welding Inspectors
- Contract Gas Construction Company Supervisors
- Contract Gas Construction Company Welders
- Contract NDT Personnel

4.0 General

4.1 All AIC and contractor personnel performing work for AIC or on its facilities shall follow the specifications, procedures, regulations, and codes presented or referenced (directly or indirectly) herein.

4.1.1 This means to follow the latest edition of regulations and codes that have been adopted by reference in the current 49 CFR Part 192 Regulations.

4.1.2 All welding must be performed using a qualified procedure and by a qualified welder in accordance with respective requirements addressed below.

UNCONTROLLED IF PRINTED

- 4.2 See [Subsection 10.3](#) for listed specifications for approved nondestructive testing procedures.

5.0 Welding Procedures (§192.225)

- 5.1 The AIC qualified welding procedures (WPS) shall comply with 49 CFR Part 192, Subpart E of the Federal PHMSA-OPS Regulations and the latest incorporated by reference (IBR) edition of API Std 1104 under §192.7.
- 5.2 Welding to establish procedures must be performed by a qualified welder in accordance with the welding requirements outlined herein.
- 5.3 Each test weld used to qualify the WPS shall have the integrity verified by destructive testing in accordance with applicable industry welding standards, namely API Std 1104.
- 5.4 Each separate procedure must be qualified, and the test documented on a Welding Procedure Qualification Report (WPQR) form.
- 5.4.1 The qualifying tests shall be recorded in detail, to include the results.
- 5.4.2 The WPQRs will be maintained by the AIC Training Section.
- 5.5 The WPSs are listed as reference material in [WELD 4](#). New or updated procedures approved by the Gas Standards and Procedures personnel can be used prior to being published in the O&M. These new or updated procedures will be published in the next O&M update.
- 5.6 Contractors or fabrication shops may have their welding procedures reviewed and approved by the Supervisor Technical Training - Welding and Gas Standards and Procedures personnel. For construction of pipelines and piping systems, see [WELD 2.3](#).

6.0 Qualification of Welders (§192.227)

- 6.1 Each AIC or contract welder must be qualified in accordance with 49 CFR Part 192, Subpart E, §192.227 and latest IBR edition of API Std 1104 per §192.7.
- 6.2 An AIC or contract welder who is to make a welded service line connection to a main must first perform an acceptable test weld under Section II of Appendix C to Part 192.
- 6.3 For more specific welder qualifications, see [WELD 2.2](#).

7.0 Limitations on Welders (§192.229)

- 7.1 No welder whose qualification is based on nondestructive testing may weld on compressor station pipe and components.
- 7.2 No welder may weld with a particular welding process unless, within the *preceding 6 calendar months*, they have been engaged in welding with that process.
- 7.3 A welder may not weld on pipe to be operated at a pressure that produces a hoop stress of 20% or more of SMYS unless:
- 7.3.1 The welder has had one weld tested within the *preceding 6 calendar months*,
AND
- 7.3.2 Weld was found acceptable under API Std 1104, Section 6, Qualification of Welders and/or Section 9, Acceptance Standards for Nondestructive Testing.
- 7.4 Welders may maintain an ongoing qualification status by performing welds that are tested and found acceptable (see 7.3.2) at least *twice each calendar year*, (but not at intervals exceeding 7-1/2 months).

8.0 Preparation for Welding (§192.235)

- 8.1 Before beginning any welding, the welding surface must be clean and free of any material that may be detrimental to the welding process.
- 8.2 Pipe or component must be aligned to provide the most favorable condition for depositing root bead. The alignment must be preserved while root bead is being deposited.
- 8.3 Welding operations must be protected from weather conditions that would impair quality of the completed weld. (Reference §192.231.)

9.0 Inspection and Test of Welds (§192.241)

- 9.1 Visual inspection of welding must be conducted by an individual qualified by appropriate training and experience to ensure the weld is acceptable and in accordance with the approved and appropriate welding procedure.
- 9.2 Welds on a pipeline to be operated at a pressure that produces a hoop stress of 20% or more of SMYS must be nondestructively tested, except:
 - 9.2.1 Welds that are visually inspected and approved by a qualified welding inspector need not be nondestructively tested if:
 - 1. The pipe's nominal diameter is less than 6 inches, OR
 - 2. The pipeline is to be operated at a pressure that produces a hoop stress of less than 40% of SMYS and the welds are so limited in number that nondestructive testing is impractical.
- 9.3 The acceptability of a weld that is nondestructively tested or visually inspected is determined according to the standards in API Std 1104, Section 9, "Acceptance Standards for Nondestructive Testing".

Should a girth weld be found unacceptable under those standards for a reason other than a crack, and if Appendix A to API Std 1104 applies to the weld, the acceptability may be further determined under that appendix. Contact AIC Gas Training Center if assistance is needed to determine the weld acceptance.

10.0 Nondestructive Testing (§192.243)

- 10.1 Nondestructive testing of welds must be performed as follows:
 - 10.1.1 By any process, other than trepanning, that will clearly indicate defects that may affect the weld integrity.

"Trepanning" is destructive intervention in which a hole is drilled or scraped into the pipe or other material surface (or possibly cutting a test strap) to address or evaluate a problem. That method of testing shall not be used.

- 10.1.2 In accordance with written procedures and by persons trained and qualified in the established procedures using equipment employed in their testing.

- 10.2 API Std 1104, Section 9, "Acceptance Standard for Nondestructive Testing" will be used for proper interpretation of each nondestructive test to ensure the acceptability of the weld.
- 10.3 Welds on pipelines requiring nondestructive inspection will be tested in accordance with one of approved methods included in the following sections:
 - 10.3.1 Radiographic Testing: see [WELD 2.6](#).
 - 10.3.2 Magnetic Particle Testing: see [WELD 2.7](#).
 - 10.3.3 Liquid Penetrant Testing: see [WELD 2.8](#).
- 10.4 When nondestructive testing is required, see Table 1 for the percentage of each day's field butt welds, selected at random by the operator, that must be nondestructively tested over their entire circumference:

Table 1: Inspection Percentage

Location	Daily Percentage Required
Class 1, except offshore	At least 10%
Class 2	At least 15%
Class 3 and Class 4	100% *
At crossing of major navigable rivers	100% *
Within railroad and public highway ROW	100% *
In tunnels, on bridges, overhead road crossings	100% *
At pipeline tie-ins, including tie-ins for replacement sections	100%
* Note: If impractical, then a minimum of 90% required.	

- 10.5 Where a welder is isolated from the principal welding activity, a *sample of each welder's work for each day* must be nondestructively tested when testing is required as determined for Inspection and Test of Welds ([Section 9.0](#)).
- 10.6 Complete nondestructive testing and associated repairs before a pipeline segment is subjected to leak and/or strength testing. As required, nondestructively test the final tie-in welds prior to pressurizing the pipeline segment.
- 10.7 When nondestructive testing is required, a record must be retained for life of the pipeline as follows:
 - 10.7.1 Record showing inspections by milepost, engineering station, or by geographical features,
 - 10.7.2 Number of girth welds made,
 - 10.7.3 Number of welds nondestructively tested,
 - 10.7.4 Number of welds rejected, AND
 - 10.7.5 Disposition of the rejects.
- 10.8 If AIC requests the actual radiographic film be retained, it shall be processed, handled, and stored in a manner such that the images can be interpreted for at least 3 years. Gas Tech Engineering will file/store the film. See [WELD 2.6](#).

11.0 Repair or Removal of Defects (§192.245)

- 11.1 Each weld that is unacceptable through nondestructive testing or visual inspection must be removed or repaired.

- 11.2 Each weld that is repaired must have the defect removed down to sound metal and the repair segment must be preheated if conditions exist that would adversely affect quality of the weld repair.
- 11.3 The repaired segment must be inspected in the same manner that the defect was found to ensure acceptability.
- 11.4 Weld repair by removal on pipe that is in a fixed position, where the pipe ends cannot be brought back together, shall be cut-out as a pipe segment per Table 2:

Table 2: Required Pipe Segments for Fixed Pipe

Nominal Pipe Size (In.)	Minimum Length
Up thru 8	12"
Greater than 8	At least 1-1/2 times the diameter

- 11.5 Weld repair on pipe that is not fixed in position (i.e., on skids or jack stands) is allowed by cutting out 1 inch on each side of the weld and reposition pipe back together. Then re-weld using the original weld procedure.
- 11.6 In order to avoid overlapping Heat Affected Zones (HAZ), there should be a *minimum 1 inch between welds*.
- 11.7 Repair of a crack, or of any defect in a previously repaired area must be in accordance with appropriate procedures that have been qualified under 49 Part 192, Subpart E and API Std 1104.
 - 11.7.1 Repair procedures must provide that the minimum mechanical properties specified for the welding procedure used to make the original weld are equally met upon completion of the final weld repair.
 - 11.7.2 Welds shall be repaired with the original AIC welding procedure or an approved AIC repair procedure.

12.0 Production Weld Quality Issues

- 12.1 Whenever a production weld quality issue is identified through visual inspection or non-destructive testing, it shall be fully investigated, and a corrective action plan developed / implemented according to the procedure outlined below and shown in the flow chart (see [Appendix A](#)).
- 12.2 Report all weld quality issues identified to the Training Superintendent Gas Construction & Operations and Welding Training Supervisor, who will provide notification to Region Operations and/or Construction Services.
- 12.3 Establish an investigation team to review the weld quality issue and develop a corrective action plan.
- 12.4 In event that the investigation team does not gain consensus on the issue or the corrective action plan, the team shall report their findings to the Training Superintendent, Region Gas Superintendent, and Gas Compliance who shall do the following:
 - 12.4.1 Review the investigation team findings,
 - 12.4.2 Develop a recommendation for corrective action, AND
 - 12.4.3 Forward the results to AIC Senior Leadership for review and approval.
- 12.5 Implement the adopted corrective action plan.
- 12.6 Quality Assurance shall monitor the effectiveness of the corrective action plan and report results back to the investigation team.

End of Instructions.

Operator Qualification (OQ) Required?

Yes

- 0601: NDT - Radiographic Testing
- 0611: NDT - Liquid Penetrant Testing
- 0621: NDT - Magnetic Particle Testing
- 0631: NDT - Ultrasonic Testing:
- 0641: Visually Inspect Pipe and Components Prior to Installation
- 0801: Welding
- 0811: Visual Inspection of Welding and Welds
- 1051: Fit-Up of Weld Type Repair Sleeve

Appendices

[Appendix A - Flow Chart for Production Weld Quality Issues](#)

Attachments

NONE.

Compliance Requirements

- 49 CFR Part 192 - Transportation of Natural and Other Gas by Pipeline: Minimum Federal Safety Standards, specifically Subpart E - Welding of Steel in Pipelines
- API Std 1104, Welding of Pipelines and Related Facilities, including Appendix B (Latest IBR edition within 49 CFR Part 192)
- Illinois Commerce Commission (ICC) Title 83: Public Utilities, Part 590, Minimum Safety Standards for Transportation of Gas and for Gas Pipeline Facilities, available online [here](#).

Reference Documents

- [WELD 2.2 Welding: Welder Qualifications](#)
- [WELD 2.3 Welding: Construction of Pipelines](#)
- [WELD 2.6 Welding: Radiographic Testing](#)
- [WELD 2.7 Welding: Magnetic Particle Testing](#)
- [WELD 2.8 Welding: Liquid Penetrant Testing](#)
- [WELD 4 Welding: Forms and Reference Materials](#)

Document Rescission

WELD 1 Welding: Requirements, April 1, 2020.

Revision Notes

Location of Changes	Summary of Changes
Not applicable.	This is a new document.

UNCONTROLLED IF PRINTED

Appendix A - Production Weld Quality Issues Flow Chart

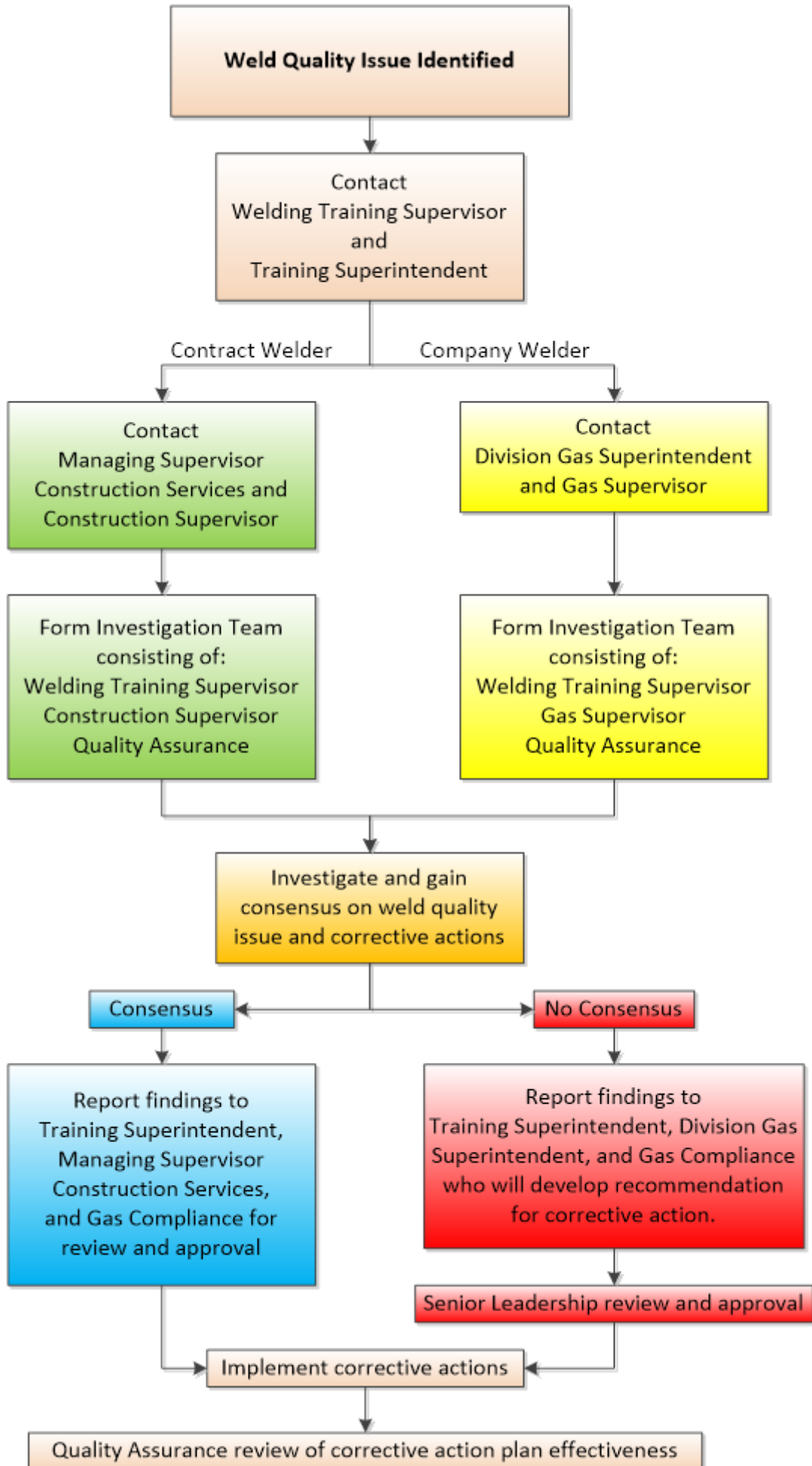

UNCONTROLLED IF PRINTED

WELDING

October 1, 2021

WELD 2.1 Safe Welding Practices**1.0 Purpose**

This document addresses various safety considerations for welding activity throughout Ameren Illinois (AIC) gas operations. As such, the area shall be inspected by the AIC representative responsible for authorizing such operations before cutting or welding is permitted.

2.0 Scope

This document addresses the following:

[3.0 Target Audience](#)[4.0 Activity Areas](#)[5.0 Fire Guard](#)[6.0 Supervisor Role](#)[7.0 Welder Responsibilities](#)[8.0 Welding or Cutting on Containers](#)[9.0 Protection of Personnel](#)[10.0 Ventilation](#)[11.0 Equipment](#)**3.0 Target Audience**

- Gas Tech Engineering (GTE)
- Gas Integrity Management Personnel
- Gas Engineers
- Gas Superintendents
- Gas Supervisors
- Gas Field Personnel - Welders
- Gas Construction Services Superintendents
- Gas Construction Services Supervisors
- Gas Contract Welding Inspectors
- Contract Gas Construction Company Supervisors
- Contract Gas Construction Company Welders
- Contract NDT Personnel

4.0 Activity Areas

4.1 Cutting or welding shall not be permitted in the following situations:

4.1.1 In areas not authorized by the AIC representative.

4.1.2 In buildings with sprinklers while such protection is impaired.

4.1.3 In areas near the storage of large quantities of exposed, readily ignitable materials.

4.1.4 In areas monitored by fire detection systems, until such time that the detection system has been appropriately disabled and alternate means of fire protection provided.

4.2 Cutting or welding shall be permitted only in areas that are, or have been made, free of flammable vapors (i.e., below 30% of LEL) and fire safe.

UNCONTROLLED IF PRINTED

- 4.3 When work cannot be moved practically, as in some construction or repair work, the area shall be made safe by removing combustibles or protecting combustibles from ignition sources.
- 4.4 Where practicable, all combustibles shall be relocated at least 35 feet from the work site.
 - 4.4.1 Where relocation is impracticable, combustibles shall be protected with flame-proofed covers or otherwise shielded with metal guards or curtains.

5.0 Fire Guard

- 5.1 A fire guard is required whenever welding is performed in locations where combustibles exist that might be ignited by sparks from the welding operation, or any of the following conditions exist:
 - 5.1.1 Combustible material, which is less than 35 feet from the operation.
 - 5.1.2 Measurable quantity of combustibles that are more than 35 feet away from the operation but are easily ignited by sparks.
 - 5.1.3 Wall or floor openings within 35 feet that expose combustible material in adjacent areas, including concealed spaces in walls or floors.
 - 5.1.4 Combustible materials that are adjacent to the opposite side of metal partitions, walls, ceilings, or roofs and are likely to be ignited by conduction or radiation.
- 5.2 The fire guard shall have the proper fire extinguisher at the location where the welding is being performed and be trained in its use.
- 5.3 The fire guard shall be familiar with facilities for sounding an alarm in event of a fire.
- 5.4 The fire guard shall be alert for fires in all exposed areas, try to extinguish them only when obviously within the capacity of equipment available, or otherwise sound the alarm.
- 5.5 A fire watch shall be maintained until such time that the area has been completely inspected to preclude the possibility of smoldering fires.

6.0 Supervisor Role

- 6.1 Supervisors shall recognize their responsibility for safe usage of cutting and welding equipment and consider the following:
 - 6.1.1 Based on fire potential for the facility, establish areas for routine cutting and welding, and, if needed, establish additional procedures for cutting and welding in other areas.
 - 6.1.2 May designate a qualified individual to be responsible for authorizing cutting and welding operations in areas not specifically designated for such processes.
 - 6.1.3 Insist that cutters or welders are suitably trained in the safe operation of their equipment and safe use of the process.
 - 6.1.4 Advise all contractors about flammable materials or hazardous conditions should they not be aware.
 - 6.1.5 Determine whether the work will be conducted in a confined space in accordance with AIC procedures. See [CONF 1](#).

7.0 Welder Responsibilities

- 7.1 The welder shall be responsible for the following:

- 7.1.1 Safe handling of the cutting or welding equipment and safe application of the cutting or welding process.
- 7.1.2 Determining the flammable and combustible materials and hazardous areas present, or likely to be present, in the work location, to include using a portable gas detector if appropriate.
- 7.1.3 Protecting flammable and combustible materials from ignition by the following:
 - 1. Move work to a location free from dangerous materials.
 - 2. If work cannot be moved, have the material moved a safe distance from the work area or have the materials properly shielded against ignition.
 - 3. See that cutting and welding are scheduled so that operations that might expose flammable and combustible materials to ignition are not started during cutting or welding.
- 7.1.4 Note on the Job Briefing and /or secure authorization such as a "Hot Work" permit for the cutting or welding operations from appropriate supervision.
- 7.1.5 Determining that conditions are safe before beginning welding operations.
- 7.1.6 Determining that fire protection and extinguishing equipment are properly located at the site before beginning welding.
- 7.1.7 Where a fire watch is required, verify that fire guard is available at site before beginning the welding operation.

8.0 Welding or Cutting on Containers

8.1 Used Portable Containers:

- 8.1.1 Perform no cutting, welding, or other hot work on used drums, barrels, portable tanks, or other containers unless specifically approved by AIC Engineering and Safety Representatives.

8.2 Venting and Purging:

- 8.2.1 Prior to cutting or welding, all hollow spaces, cavities, or containers shall be vented to permit the escape of air or gases.
- 8.2.2 Where any question, recommend purging the container with inert gas.
- 8.2.3 Testing shall be conducted to ensure the oxygen content is safe for welding.

9.0 Protection of Personnel

9.1 General

- 9.1.1 *Railing:* When working on scaffolds, or runways more than 4 feet above ground, protect the welder or helper against falling. This may be accomplished by:
 - 1. Railings (primary means),
 - 2. Body harnesses, OR
 - 3. Some other equally effective safeguards.

The area below such work area shall be considered a hard hat area.

- 9.1.2 **Welding Cable:** Welders shall place welding cable and other equipment so that it is clear of passageways, ladders, and stairways.
- 9.1.3 **Welding in Excavations:** When welding in an excavation/trench, follow all requirements in the Excavation Safety section (see [EXCV](#)) to protect workers from excavation related hazards, including cave-ins. Protect welders working in excavations from accumulation of welding fumes as specified in the ventilation section below.

9.2 Eye/Ear/Face Protection

9.2.1 Selection

- 1. Use welding helmets/hoods during all arc welding operations. Provide helpers or attendants with proper eye protection. Safety glasses should be worn under a welding hood or face shield.
- 2. Use goggles or other suitable eye protection during all gas welding or oxygen cutting operations.
- 3. Helmets and hand shields shall be designed and positioned to protect the face, neck, and ears from direct radiant energy from the arc.
- 4. Welding helmets shall be provided with filter plates and cover plates designed for easy removal.
- 5. See Table 1 for the selection of proper shade numbers. These recommendations may be varied to suit the individual's needs.

Table 1: Welding Shade Numbers

Welding Operations	Shade No.
Shielded Metal Arc Welding (SMAW)	9 - 10
Gas Metal Arc Welding (GMAW)	10 - 11
Submerged Arc Welding	Shaded glasses (3 - 4) to guard against occasional arc flash

- 6. All filter lenses and plates shall meet the test for transmission of radiant energy prescribed in ANSI 287. "American National Q Standard Practice for Occupational and Educational Eye and Face Protection."

9.2.2 Where the work permits, the welder should be enclosed in:

- 1. An individual booth, painted with a finish that is low reflection, such as zinc oxide (an important factor for absorbing ultra-violet rays), or
- 2. Enclosed with noncombustible screens that are similarly painted.
- 3. Booths and screens shall be situated as to comply with Welding Screens and Booths (see [Subsection 9.5](#)).

9.2.3 Ear Plugs are recommended to keep sparks out of the ear canal.

9.3 Protective Clothing

- 9.3.1 **General Requirements:** Protect personnel exposed to the hazards created by welding or cutting operations by personal protective equipment. Appropriate protective clothing required for any welding operation will vary with the individual's size, nature, and location of the work to be performed.

9.3.2 **Clothing Selection:**

1. Clothing should provide enough coverage and be made of suitable materials to prevent skin burns caused by sparks, spatter, or radiation.
2. Synthetic or plastic materials that can melt and cause severe burns are not recommended for use as clothing near welding arcs.
3. All outside clothing such as jumpers or overalls should be reasonably free from oil or grease.
4. Sparks may lodge in rolled-up sleeves, clothing pockets, or overalls/ trouser cuffs. Therefore, recommend:
 - 4 a. Sleeves and collars be kept buttoned and pockets be eliminated from the front of clothing. When pockets are present, they should be emptied of flammable or readily combustible materials.
 - 4 b. Trousers or overalls should not have cuffs and should not be turned up on the outside.

9.3.3 *Caps & Gloves*: All welders and cutters shall wear protective flame-resistant caps & gloves. Recommend using gloves made of leather or other suitable material for the "spark environment."

9.3.4 *Capes & Sleeves*: Cape sleeves or shoulder covers with bibs made of leather or other flame-resistant material should be worn during overhead welding or cutting operations.

9.4 Noise Control

9.4.1 The most direct way to control excessive noise is to reduce the intensity at the source. When control methods fail to bring noise exposure within allowable limits, then employ personal protective devices (i.e., earmuffs or earplugs).

9.5 Welding Screens and Booths

9.5.1 Where welding is required in or around populated areas, welding screens or booths shall be established to avoid the possibility of "arc burn" or other injury to the general public or fellow employees.

1. To minimize ventilation restriction, it is desirable to have screens / booths mounted approximately 1 to 2 feet above the floor.
2. Screens must be secured to avoid being knocked over or displaced by windy conditions.

9.6 See [WELD 1, Subsection 8.3](#) regarding weather protection.

10.0 Ventilation

10.1 Adequate ventilation (natural or mechanical) must be provided for all welding and cutting related operations.

10.1.1 This means enough ventilation that exposure to hazardous concentrations of airborne contaminants is maintained below allowable levels for personnel.

10.2 The area environment where welding or cutting is performed should be checked with a gas detection instrument, as necessary, to ensure environment is non-hazardous and is not oxygen deficient. The check must always be conducted when performing these operations in confined spaces.

10.3 Natural ventilation (i.e., natural air currents or wind) is acceptable only for performing welding, cutting, and related processes outdoor.

10.4 Mechanical Ventilation

- 10.4.1 AIC Safety Specialist should be contacted with any question regarding requirements for mechanical ventilation.
- 10.4.2 To maintain adequate air quality, mechanical ventilation must be used when welding and cutting:
1. Indoors,
 2. In confined spaces, AND
 3. In excavations, as necessary.
- 10.4.3 Mechanical ventilation consists of general room ventilation or local exhaust ventilation.
- 10.4.4 Local exhaust ventilation is preferred, with the following precautions taken:
1. The system shall be of enough capacity and arranged to remove fumes and smoke at the source and ensure any concentration in the breathing zone is within safe limits.
 2. Local exhaust ventilation shall consist of freely movable hoods to be placed by the welder as close as practical to the work area.
 3. The system exhaust must be situated to ensure that welding fumes and smoke are not dispersed to other work areas or re-entrained into the building make-up air.
- 10.4.5 If general mechanical (room) ventilation is used, the following conditions must be met:
1. Space at more than 10,000 cubic feet per welder in an enclosed area (i.e., a building).
 2. Ceiling height is more than 16 feet.
 3. Welding is not done in confined space, such as tanks, etc.
 4. Welding space does not contain partitions, balconies, or other structural barriers that significantly obstruct cross ventilation.
 5. The welding area is maintained generally clear of visible welding fumes. Welding area is sufficiently separated from adjoining building areas to prevent welding fumes from moving into those areas.

11.0 Equipment

11.1 Gas Bottles

- 11.1.1 Handle and transport oxygen and acetylene cylinders with extreme care to avoid damage to cylinders. Always maintain valve protection caps on cylinders when they are in transit or storage.
- 11.1.2 Acetylene cylinders shall only be transported and used in the vertical (upright) position. This will ensure that the liquid acetone within the cylinder will not get into the regulator and/or hose, thus creating a potential for a fire or explosion.
- 11.1.3 Secure all gas bottles with chains or other adequate supports when being used to prevent them from being pulled or knocked over.

11.2 Regulators

11.2.1 Turn off all regulators and gas bottle valves (oxygen and acetylene) when not in use.

11.2.2 Relieve the (regulator) pressure by opening the torch valves after the bottle valves are closed.

11.3 Hoses

11.3.1 Maintain oxygen and acetylene hoses in good condition and check all fittings for tightness.

11.3.2 Ensure oxygen hoses are green color and acetylene hoses are red.

11.3.3 Replace hose if any question about its condition.

11.3.4 Never use any oil or grease on any hose fittings or regulators.

11.3.5 Cutting and welding torches should be fitted with an anti-flashback check valve.

11.4 Welding Machines and Cables

11.4.1 All welding machines shall be operated in accordance with the manufacturer's safety practices.

11.4.2 Ensure ground connections and welding cables are the proper size for amperage being used.

11.4.3 Promptly repair or replace damaged cables, worn spots, and loose cable connectors.

11.4.4 Any connector or welding cable that is "more than warm to the hand during welding" is an indication of excessive resistance and the problem should be corrected.

11.5 Electrode Holders

11.5.1 Electrode holders shall be rated for the amperage being used for the specific procedure.

11.5.2 Insulated electrode holders are preferred for all AIC welding.

11.5.3 The AIC welding inspector may require the use of insulated electrode holders for specific applications.

End of Instructions.

Operator Qualification (OQ) Required?

YES

0801: Welding

Appendices

NONE.

Attachments

NONE.

Compliance Requirements

NONE.

UNCONTROLLED IF PRINTED

Reference Documents

[CONF 1 Confined Spaces: Requirements](#)

[EXCV - Excavation Safety](#) (multiple documents)

[WELD 1 Welding: Requirements](#)

Document Rescission

WELD 2.1 Welding: Safe Welding Practices, October 1, 2020

Revision Notes

Location of Changes	Summary of Changes
Subsection 5.2	Revised – The fire guard shall have the proper fire extinguisher at the location where the welding is being performed and be trained in its use.
Subsection 10.2	environment replaces atmosphere

WELDING

October 1, 2021

WELD 2.2 Welder Qualifications**1.0 Purpose**

This document establishes the requirements for the qualification and certification of welders for construction, fabrication, and pipeline maintenance welding of pressure piping systems for Ameren Illinois (AIC). It is in accordance with 49 CFR Part 192, §192.227 Qualification of welders and welding operators, and §192.229 Limitation on welders and welding operators.

2.0 Scope

This document addresses the following:

[3.0 Target Audience](#)[4.0 General](#)[5.0 Welding Inspector](#)[6.0 Qualification Categories - Initial Test](#)[7.0 Service Line Connection Welding \(Service Tee\)](#)[8.0 Workmanship](#)[9.0 Welder Requalification](#)[10.0 Destructive Testing](#)[11.0 ASME Piping](#)[12.0 Records and Retention \(§192.227\)](#)

Appendices

[Appendix A - Welder Positions](#)**3.0 Target Audience**

- Gas Tech Engineering (GTE)
- Gas Integrity Management Personnel
- Gas Engineers
- Gas Superintendents
- Gas Supervisors
- Gas Field Personnel - Welders
- Gas Construction Services Superintendents
- Gas Construction Services Supervisors
- Gas Contract Welding Inspectors
- Contract Gas Construction Company Supervisors
- Contract Gas Construction Company Welders
- Contract NDT Personnel

4.0 General

- 4.1 Welder Qualification testing is to determine the ability of the welder (AIC personnel or contractor) to make sound welds.
- 4.2 Upon completion of an initial qualification test, the welder is limited to the process and can weld within the essential variables (see API 1104, Section 6 and/or API 1104, Appendix B) for which qualification was made.
- 4.3 Re-qualification (6-month and annual) allows a welder to keep welding in that process.

UNCONTROLLED IF PRINTED

- 4.4 No welder whose qualification is based on nondestructive testing may weld compressor station pipe and components.
- 4.5 Welder qualification shall be conducted at locations approved by the Training Supervisor - Welding or an AIC approved welding inspector.

5.0 Welding Inspector

- 5.1 Welder qualification shall be conducted under the supervision of an AIC approved welding inspector/observer.
- 5.2 An independent testing agency may be used to provide "destructive testing" and to document the qualification testing of welders.
- 5.3 The welding inspector shall have been trained in using the AIC Gas O&M Plan and applicable codes/standards, plus have previous experience in testing welders.
- 5.4 Supervisor Technical Training - Operations [Welding] shall ensure that all welding is conducted in accordance with the approved welding procedures (WPS), standards, and codes.
- 5.5 The Training Supervisor - Welding shall be responsible to ensure all welder qualification records are processed and distributed in accordance with the AIC Gas O&M Plan.

6.0 Qualification Categories - Initial Test

6.1 General

- 6.1.1 All AIC and contract welders working on AIC pressure piping systems shall be qualified in one or more of the categories defined below.
- 6.1.2 Qualification in a single category qualifies a welder to weld only in that specific category with the welding process as used for test.
- 6.1.3 All testing will be on material Grade B or greater, but not to exceed SMYS 60,000 psi (X60).
- 6.1.4 It is preferred that all welders using "Gas Metal Arc Weld (GMAW)" be qualified first in "Shielded Metal Arc Weld (SMAW)".
- 6.1.5 All welders shall test using the same welding techniques, travel speed, and machine settings as for "field" welding.
- 6.1.6 All field welding shall follow the AIC approved Welding Procedures (WPS).
- 6.1.7 The welder will be given time to establish appropriate machine settings prior to actual testing.
- 6.1.8 Welds will be tested in accordance with the latest edition incorporated by reference (IBR) of API 1104, Section 6, Qualification of Welders.

6.2 AIC Welder Qualification Categories

- 6.2.1 For welder qualification categories, see Table 1.

Table 1: Welder Qualification Categories

Category	Description	Reference
Pipeline - SINGLE (Ref API 1104, Section 6.2)	Pipelines governed by & inspected to PHMSA Part 192 and API 1104 requirements.	Section 6.3

Pipeline - MULTIPLE (Ref API 1104, Section 6.3)	Pipelines & related fabrications governed by & inspected to PHMSA Part 192 & API 1104 requirements	Section 6.4
IN-SERVICE (Ref API 1104, Appendix B)	Welding on pressurized gas pipelines in accordance with API 1104, Appendix B "In-Service Welding."	Section 6.5
ASME PIPING (Used as needed) (Ref BPVC, Section IX)	Piping systems constructed/inspected in accordance with ASME B31.3.	Section 11.0

6.3 Pipeline - Single Qualification (Butt/Branch welds on nominal pipe diameters)

- 6.3.1 Welders qualifying for a specific pipe diameter may qualify in accordance with API 1104, "Qualification of Welders - Single Qualification," and the requirements of this section.
- 6.3.2 A welder may qualify on multiple diameters and wall thickness singularly as outlined in Table 2.

Table 2: Welder Qualification - Single Type

Test ID.	Type Weld	Size Pipe (Inches)	Wall Thickness (inch)	No. of Tests
1	Butt	1-1/4	< 0.188	2
2	Butt	2	< 0.188	2
3	Butt	4	≥ 0.188	1

Note: Tests 1 thru 3 singularly qualify welder to make a Butt & LAP welds ≤ 12.75" OD / ≤ 0.750" WT.

- 6.3.3 Welders qualifying under these requirements shall make a complete groove weld on pipe with the axis of the pipe 45° inclined, fixed plane (6G) position. See [Appendix A](#) for the different welder positions.
- 6.3.4 Welding shall be done in accordance with the applicable AIC welding procedure.
- 6.3.5 The pipe diameter and wall thickness shall be in accordance with the project requirements.
- 6.3.6 A welder making a single-qualification test for branch connections, fillet welds, or other similar configurations shall follow the specific Welding Procedure Specifications for branch connections. See Table 3.

Table 3: Welder Qualification - Branch Connection

Test ID.	Type Weld	Size (Inches)	Wall Thickness (inch)	No. of Welds
1	"Branch-on" fillet	1-1/4 on 2	≥ 0.188	1
2	"Branch-on" fillet	2 on 4	≥ 0.188	1

Notes:

1. These initial tests (singular application) will be in the 5F position (branch out the side) as full-penetration welds. See [Appendix A](#).

2. These tests qualify the welder to make all position branch type welds on pipe 12.75" OD and ≤ 0.750 " thickness.

6.3.7 Successful completion of these tests, in accordance with API 1104, "Qualification of Welders," qualifies the welder for the group diameter and wall thickness range which was used for qualification, subject to the essential variables listed in "Single Qualification" of API 1104.

6.4 Pipeline/Fabrication -- Multiple Qualification

6.4.1 Welders qualifying under pipeline/fabrication requirements shall make 2 welds described herein in accordance with "Multiple Qualification" of API 1104.

6.4.2 The 1st test shall be a groove weld (open butt weld).

1. The test pipe to have a minimum outside diameter of 12.75" and wall thickness ≥ 0.250 ".
2. Test pipe will be placed and welded in *either* the horizontal-fixed (5G) or the 45°-fixed (6G) position. For positions, see [Appendix A](#).

6.4.3 The 2nd test will be a "branch on" full-penetration groove fillet-weld test in the horizontal fixed position.

1. This test will use ≥ 12.75 " OD pipe with a wall thickness ≥ 0.250 ".
2. Welder shall layout, cut, fit, and weld a full-size branch-on-pipe connection.
3. A full-size hole shall be cut in the main run pipe.

6.4.4 Completing both tests successfully in accordance with "Multiple Qualification" of API 1104, qualifies the welder for the following, subject to the essential variables listed in "Multiple Qualification" of API 1104:

1. All positions,
2. All diameters,
3. All wall thicknesses, and
4. All joint designs and fittings.

6.5 In-Service Welding Test

6.5.1 All welders working on pressurized gas piping systems above 100 psig that require an in-service procedure shall be qualified in accordance API 1104, Appendix B, "In-Service Welding", using an approved AIC welding procedure.

6.5.2 Qualification will be done on 12.75" OD pipe branch-on test (no hole in run pipe).

6.5.3 The qualification grouping for pipe diameters and wall-thicknesses shall be in accordance with API 1104.

6.5.4 Branch-on fitting (full penetration groove weld with fillet reinforcement):

1. Pipe at 12" nominal diameter.
2. Pipe thickness at minimum 0.250".
3. Run pipe in horizontal position with branch out the side (5F position). See [Appendix A](#).

6.5.5 The weld should be tested and considered acceptable if it meets the requirements of API 1104, Appendix B, "In-Service Welding" and "Visual Examination and Destructive Testing".

- 6.5.6 Only Low-Hydrogen welding electrodes will be used for welding on AIC High-Flow Pressurized piping systems operating above 100 psig in accordance with the approved AIC in-service welding procedures (WPS) and [WELD 2.4](#).
- 6.5.7 In-Service Reference Codes and Standards:
1. PHMSA 49 CFR Part 192:
 - 1 a. Subpart E, Welding of Steel in Pipelines,
 - 1 b. Subpart M - Maintenance,
 - 1 c. Appendix B, Section II.B., Weldability, and
 - 1 d. Appendix C to Part 192 - Qualification of Welders for Low Stress Level Pipe
 2. API Std 1104 - Welding of Pipelines and Related Facilities, Appendix B - In-Service Welding
 3. ASME B31.8 - Gas Transmission and Distribution Piping Systems
 4. PRCI L51660 - Development of Simplified Weld Cooling Rate Models for In-Service Gas Pipelines
 5. PRCI L52047 - Updated Pipeline Repair Manual, Revision 6.

7.0 Service Line Connection Welding (Service Tee)

- 7.1 All welders doing service line welding on 2" or less pipe shall weld two ¾" service line connection fittings in the 2F position. See [Appendix A](#).
- 7.2 These welds must be in accordance with, and found acceptable to, Appendix C to Part 192 - Qualification of Welders for Low Stress Level Pipe. There is additional test for welders of service connections to mains.

8.0 Workmanship

- 8.1 All welder qualification and re-qualification test welds shall pass visual inspection to *demonstrate good workmanship* and uniform weld profiles around the entire pipe circumference.
- 8.1.1 Arc burns on the pipe surface are not permitted.
 - 8.1.2 Undercut must fall within tolerance as set forth in API 1104, Table 4, "Maximum Dimensions of Undercutting."
 - 8.1.3 Filler wires are to be kept to a minimum.
 - 8.1.4 Complete fusion is required on both the root and cap pass.
 - 8.1.5 Weld must be free from:
 1. Cracks.
 2. Burn through.
- 8.2 AIC (approved testing personnel) shall have the right to terminate welder test at any time if candidate does not possess the skills required to make the quality of weld required by this specification.
- 8.3 Any welder who makes a weld that fails to comply with requirements of this section may be disqualified from further work at discretion of the AIC Supervisor Technical Training - Operations [Welding] or Welding Inspector Supervisor.

8.4 Any AIC Supervisor may ask for review of a welder whose welding skill is in question (e.g., excessive leaks, poor workmanship, untimely job completion). See [WELD 1, Section 12.0](#), Production Weld Quality Issues.

9.0 Welder Requalification

9.1 Requalification - General

9.1.1 Welders that have not welded in their qualified process within 6 months shall be deemed inactive and forfeit the 6-week grace period.

9.1.2 Sample test welds to be completed by the welder while in the presence of a qualified observer or by remote observation (such as FaceTime). The welds will be tested by a qualified welding inspector for compliance with acceptance criteria per API 1104 (IBR).

9.1.3 An annual written, oral, or LMS CBT Operator Qualification (OQ) test will be given with the annual welder test.

9.2 *Annual requalification* -- Active qualified welders must complete a requalification test twice each calendar year, not to exceed 7-½ months from their initial qualification or previous requalification test.

9.2.1 The 1st test of the year is the annual qualification and the 2nd test is the 6-month test.

9.2.2 Each year the Welding Department will select the pipe sizes for the annual requalification testing.

9.2.3 *Single Qualified Welder Annual Requalification* - See Table 4A for the sample welds to be completed by the welder for annual requalification as single qualified.

Table 4A: Requalification Welding Tests - Annual Single-Qualified

Weld Type	Pipe Size (Inches)	Wall Thickness (Inch))	Position	No. of Welds
Butt Weld	Welding Dept. Choice	> 0.188	5G	1
Branch Fillet Weld (1)	2" on 4"	≥ 0.188	2F	1
Service Line	3/4 on 2 or 4	---	2F	2
Note: (1) Not required for the 6-month test.				

9.2.4 *Multi-Qualified Welder Annual Requalification* -- See Table 4B for the sample welds to be completed by the welder for annual requalification as multi-qualified.

Table 4B: Requalification Welding Tests - Annual Multi-Qualified

Weld Type	Pipe Size (Inches)	Wall Thickness (Inch)	Position	No. of Welds
Butt Weld	Welding Dept. Choice	> 0.250	5G	1
Branch Fillet Weld (1)	Welding Dept. Choice	> 0.250	4F	1
Service line	3/4 on 2 or 4	---	2F	2
Note: (1) Not required for the 6-month test.				

9.2.5 The 6-month requalification test may be taken from a production weld; however, if this is not possible, see Table 4A or 4B for welds to be made for the specified process.

9.3 In-Service Welders -- Annual and 6-Month Requalification

- 9.3.1 The annual and 6-month requalification test requirements will be the discretion of the AIC Supervisor Technical Training - Operations [Welding].
- 9.3.2 All testing and acceptance criteria will meet the essential variables of API 1104, Appendix B.

10.0 Destructive Testing

10.1 All initial weld tests shall be destructively tested. Annual and 6-month requalification may be either destructive or radiographically examined.

10.1.1 Any test weld failing to meet destructive test or alternative radiographic test acceptance criteria as set forth in API 1104 or Appendix C to Part 192 or API 1104, Section 9, Radiograph shall result in immediate test failure and that welder shall not weld on any AIC gas facilities until further testing is conducted.

- 1. AIC will implement radiographic testing of a current weld as prescribed in 49 CFR §192.229(c)(1) using API 1104, Section 9 criteria.
- 2. Attach the Level II or Level III reader's sheet to the welder's requalification report.

10.1.2 Failure to submit a weld sample test upon request, or failing to test by the scheduled date, is considered an automatic failure.

10.1.3 If a welder fails to pass a weld test because of unavoidable conditions or conditions beyond their control, the welder may be given a second opportunity to qualify.

10.1.4 If a welder fails to requalify and a qualified welding inspector / instructor is present at the time AND the cause of the failure can be determined; then options are:

- 1. Following on the spot training and procedure review, the welder will be given 1 more opportunity to submit at least 2 additional sample tests. If both tests are successful, there will be no need to perform a full test.
- 2. After at least 5 days, the welder may be re-evaluated by participating in additional training / procedure review and producing a full initial test under the supervision of a qualified welding inspector.

11.0 ASME Piping

11.1 Where needed, all welders working on ASME B31.3 piping systems shall be qualified in accordance with the requirements of ASME Section IX, "Boiler & Pressure Code".

11.2 The qualification test will be made using the pipe wall thickness and diameter that the welder will be expected to weld in production.

11.3 The pipe will be in the 6G position using an approved AIC welding procedure qualified in accordance with ASME Section IX. For welder position, see [Appendix A](#).

11.4 Qualification on pipe diameters of 2-7/8" or greater allows the welder to make groove and fillet welds in all positions and on pipe diameters from 2-7/8" and greater.

11.5 The maximum thicknesses qualified will be 2 times the actual wall thickness of the test pipe.

11.6 There is no minimum wall thickness limit for welder qualification per ASME Section IX.

12.0 Records and Retention (§192.227)

UNCONTROLLED IF PRINTED

- 12.1 The Supervisor Tech Training - Welding shall ensure all welder qualification records are processed, distributed, and filed at the Welding Training facility and/or in the Operator Qualification Department records.
- 12.2 The welder is responsible for having their "Weld Qualification Report" available for review when welding.
- 12.3 For transmission pipe installed after July 1, 2021, all welder qualification records must be retained for at least 5 years following the date of construction. To ensure proper coverage of records related to various AIC construction, other than service lines, retain all welder qualification records for a minimum of 8 years.
- 12.3.1 All welder records are retained at Pawnee Gas Training Center (paper copy) and electronic copy on the Pawnee G drive.

End of Instructions.

Operator Qualification (OQ) Required?

YES

0801: Welding

Appendices

[Appendix A - Welder Positions](#)

Attachments

NONE.

Compliance Requirements

49 CFR Part 192 - Transportation of Natural and Other Gas by Pipeline: Minimum Federal Safety Standards, specifically:

Subpart E - Welding of Steel in Pipelines,

Appendix B, Section II.B - Weldability, and

Appendix C to Part 192 - Qualification of Welders for Low Stress Level Pipe

American Petroleum Institute (API), Std 1104, "Standard for Welding Pipelines and Related Facilities", including Appendix B "In-Service Welding." (latest edition incorporated by reference)

ASME Boiler & Pressure Code, Section IX: "Qualification Standard for Welding & Brazing Procedures, Welders, Brazers, and Welding and Brazing Operators." (*This applies when welding to ASME B31.8.*)

Illinois Commerce Commission (ICC) Title 83: Public Utilities, Part 590, Minimum Safety Standards for Transportation of Gas and for Gas Pipeline Facilities, available online [here](#).

Reference Documents

[WELD 1 Welding: Requirements](#)

[WELD 2.3 Welding: Construction of Pipelines](#)

Document Rescission

WELD 2.2 Welding: Welder Performance Qualifications, April 1, 2021.

UNCONTROLLED IF PRINTED

Revision Notes

Location of Changes	Summary of Changes
Compliance Requirements	Correction ASME B31.8 not B31.3

Appendix A - Welder Positions

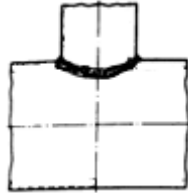

2F

Knock-Off Nipple

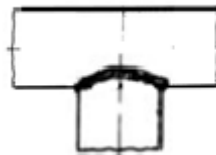

4F

Vertical-Down

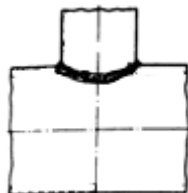

5F

Side Branch

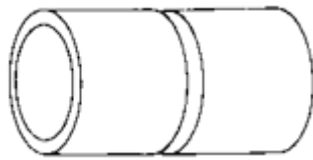

5G

Horizontal-Fixed

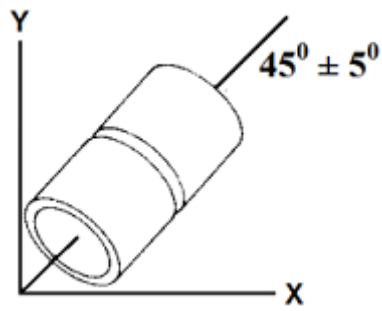

6G

45° Inclined-Fixed

WELDING

April 1, 2023

WELD 2.3 Construction of Pipelines

1.0 Purpose

This document establishes the welding and inspection requirements for the construction and fabrication of all pipelines and piping systems for Ameren Illinois (AIC). It is in accordance with 49 CFR Part 192.

2.0 Scope

This document addresses the following:

[3.0 Target Audience](#)

[4.0 Material Requirements](#)

[5.0 Welding Procedures](#)

[6.0 Welder Qualification](#)

[7.0 Welding Process](#)

[8.0 Pre-alignment Inspection](#)

[9.0 Welding Requirements](#)

[10.0 Weld Repairs](#)

[11.0 Weld Inspection](#)

[12.0 Records](#)

Appendices

[Appendix A - Joining Unequal Steel Wall Pipe and Fittings](#)

3.0 Target Audience

- Gas Tech Engineering (GTE)
- Gas Integrity Management Personnel
- Gas Engineers
- Gas Superintendents
- Gas Supervisors
- Gas Field Personnel - Welders
- Gas Construction Services Superintendents
- Gas Construction Services Supervisors
- Gas Contract Welding Inspectors
- Contract Gas Construction Company Supervisors
- Contract Gas Construction Company Welders
- Contract NDT Personnel

4.0 Material Requirements

4.1 In addition to AIC material specifications and purchase order requirements, all material, steel pipe flanges, fittings, and valves used in the construction of AIC pipelines and related piping systems shall meet the material requirements listed in Table 1.

Table 1: Material Standards & Specifications

COMPONENT	SPECIFICATION
-----------	---------------

UNCONTROLLED IF PRINTED

Pipe	API 5L, "Specification for Line Pipe" ASTM A105, "Standard Specification for Carbon Steel Pipe for High-Temperature Service" ASTM A106, "Standard Specification for Seamless Carbon Steel Pipe for High-Temperature Service" Specification for Electric-Fusion-Welded Steel Pipe for High-Pressure Service at
Fittings	ANSI B16.5, "Specification for Steel Pipe Flanges and Flanged Fittings" ASME B16.5, "Specification for Flanges and Flanged Fittings" MSS SP-75, "High-Strength, Wrought, Butt-Welding Fittings"
Valves	API 6 D, "Specification for Pipeline and Piping Valves"
Flanges	MSS- SP44, "Steel Pipeline Flanges" ASME B16.5, "Pipe Flanges and Flanged Fittings"

- 4.1.1 Steel pipe shall be legibly marked and readable with the specification or standard to which it was manufactured and the heat number so that proper welding procedure can be used.
- 4.1.2 When welding pipe that is stenciled "multi-grade," the procedure for the project design grade of pipe shall be used.
- 4.1.3 When using materials of different grades, the procedure for the highest grade of pipe shall be used.

4.2 Fitting Requirements

- 4.2.1 Fittings should be beveled to a standard 30 to 37.5 degrees.
- 4.2.2 The mating wall thicknesses of fittings and flanges should be equal to the pipe to which it is joined, or not exceeding the acceptable variations permitted for joining pipe of unequal wall. See [Appendix A](#)
- 4.2.3 Butt weld valves (by approved manufacturer) shall be of forged steel construction and should have the same mating wall thickness as the pipe to which joined, or not exceeding the acceptable variations permitted for joining pipe of unequal wall.
 - 1. The project plans or valve manufacturer shall specify whether the butt weld valve is to be in the open or closed position when welded.

5.0 Welding Procedures

- 5.1 In accordance with DOT regulations, detailed welding procedure specifications (WPS) must be established and qualified to demonstrate that welds having suitable mechanical properties and soundness are workable prior to production welding.
- 5.2 The quality of the welding procedure welds shall be determined by destructive testing in accordance with API 1104. ASME projects will follow ASME BPVC, Section IX procedures.
- 5.3 Qualification of WPS shall be in accordance with:
 - 5.3.1 API 1104, Section 5, "Qualification of Welding Procedures for Welds Containing Filler-Metal Additives" for the construction of new pipelines,
 - 5.3.2 API 1104, Appendix B for maintenance welding on existing pipelines, or
 - 5.3.3 ASME BPVC, Section IX where applicable.
- 5.4 A welding procedure shall NOT be used for pipeline construction or for repair welding prior to its approval by AIC Gas Standards and Procedures personnel.
- 5.5 All welding will follow the WPS that has been documented by a Welding Procedure Qualification Report (WPQR). The AIC procedures that are currently approved are in-

cluded in [WELD 4](#). However, new or updated WPS may be approved in advance of publishing in the next O&M update (see [WELD 1, Section 5.0](#), Welding Procedures).

- 5.6 A contractor or fabrication shop may submit their own procedure for review by AIC welding instructor and approval by Gas Standards and Procedures. The approved WPS shall always be followed while performing welding for AIC. A copy of that procedure will be maintained by AIC welding instructor and Gas Standards and Procedures.
- 5.7 The ambient temperature at which the welding procedure qualification was conducted shall be included in the WPS. The approved procedure may be used for construction at temperatures above and below the test temperature provided preheat temperatures as specified in the WPS are followed.

6.0 Welder Qualification

- 6.1 Prior to performing any welding for AIC, all welders (AIC personnel, contractor, or fabrication shop) shall be qualified in accordance with [WELD 2.2](#). All welder qualification testing shall be under the direct supervision of an approved AIC qualified welding inspector.
- 6.2 Once qualified, the welder is permitted to weld within the essential variables of their qualification test. These variables are detailed in API 1104, Section 6, "Qualification of Welders" for new construction and API 1104, Appendix B for "In-Service Welding".
 - 6.2.1 Welders shall follow an approved Welding Procedure (WPS) within the scope of those variables.

7.0 Welding Process

- 7.1 The approved field welding processes to be used for construction and fabrication are:
 - 7.1.1 Shielded Metal Arc Weld (SMAW)
 - 7.1.2 Gas Metal Arc Weld (GMAW)
- 7.2 All welding will be "Direct Current Electrode Positive" (DCEP).
- 7.3 Welding electrodes and grounding requirements include the following:
 - 7.3.1 Cellulose coated electrodes (E6010, E7010, and E8010) shall not be stored in ovens, but maintained in a dry area at a temperature above freezing and below 100 °F.
 - 7.3.2 Low-hydrogen electrodes (E7018) used for in-service welding shall be in a factory sealed container until opened. After opening sealed container, the rods shall be stored in holding ovens at 250 °F minimum to 350 °F maximum temperature.
 - 1. Rods must be returned to oven after being in ambient air for *8 hours*.
 - 2. The rods will then need a re-heat period of *48 hours* to recondition the electrode before re-use.

Discard low-hydrogen electrodes after reheating twice.

- 7.3.3 Discard all electrodes (GMAW and SMAW) that have been exposed to an atmosphere that may affect their operating characteristics or weld quality.
- 7.3.4 Electrode holders shall be the fully insulated type when used for welding on the inside of pipe.

7.3.5 The ground connection shall be constructed of steel, of similar chemical composition, with respect to the pipe and be of sufficient size to prevent overheating. It shall be fully insulated except for the one point of contact. See [Subsection 9.10](#) regarding using ground.

7.3.6 Shielding gas for GMAW is welding Grade CO₂ (Carbon Dioxide).

8.0 Pre-alignment Inspection

8.1 General

8.1.1 Prior to alignment, all pipe and/or fittings shall be inspected for defects that might impair the pipeline service life.

8.1.2 Pipe wall and bevel defects shall be repaired or removed as described herein.

8.2 Pipe Wall Defects

Defects shall be handled as specified:

8.2.1 Laminations and Cracks

1. Laminations found in the pipe wall require that the pipe be inspected by an approved ultra-sonic thickness gauge and the portion of pipe, which contains lamination, shall be cut out as a cylinder. See [REPR 1](#) for segment cutout procedure.
2. Cracks found in the pipe wall require that the portion of pipe containing a crack be cut-out as a cylinder. See [REPR 1](#) for segment cutout procedure.

8.2.2 Dents

1. All dents exceeding the specifications in API 5L (Section 9.10.5.2, 45th edition - shall be cut-out as a cylinder. See [REPR 1](#) for segment cutout procedure.

8.2.3 Gouges, Grooves, Scratches, and Notches

1. All gouges, grooves, scratches, and notches that exceed the specifications of API 5L shall be eliminated by grinding, providing the wall thickness is not reduced to below the minimum requirement. For API 5L wall thickness tolerances, see [Table 9](#) and [Table 11](#) in WELD 2.10, Arc Burn Removal.
2. Should grinding reduce the wall thickness below the minimum requirement, the area shall be cut out as a pipe cylinder. See [REPR 1](#) for segment cutout procedure.

8.3 Pipe Bevel Defects

8.3.1 Laminations

1. Laminations, or other visual defects, in the pipe bevel that exceed ¼" shall be removed by cutting out the applicable pipe as a cylinder.

8.3.2 Bevel Damage

1. Bevel damage, such as dents, gouges, or depressions, shall be repaired if their depth exceeds 1/16". Repair by grinding or filing to smooth the defect into existing bevel.
2. Damage that requires grinding to the point where the bevel may be modified from the tolerances on the welding procedures shall be rejected and the end shall be re-beveled.

8.3.3 Root Face Damage

1. The root face (land), if damaged, may be restored to its original dimension by filing or grinding.
2. Should restoration not be practicable, the end shall be completely re-beveled.

8.3.4 Bevel Dents

1. Denting restricted to top edge of the bevel shall be ground smooth and not be cause for rejection, unless, in the opinion of the welding inspector, the denting extends beyond the area where the cap pass will tie-in to the bevel edge.

9.0 Welding Requirements

9.1 Electrodes

- 9.1.1 The specific classification and type of welding electrodes used during construction and fabrication shall be as described in the approved welding procedure.
 1. Electrodes shall be ordered by their AWS classification number (e.g., E6010, E7010-G, E8010-G) based on their designation in the applicable procedure.
 2. Any change in AWS classification requires approval by the AIC Code Compliance Group.
 3. Electrode E8010-8P+ should not be used due to delayed cracking issues.
 4. See other electrode discussion under [Subsection 7.3](#).
- 9.1.2 All electrodes used by contractors should be opened in the presence of AIC inspector and dated.
 1. AIC inspector has the right to disallow the use of any electrodes that might be of questionable condition or moisture content. This applies to any welding, including welder qualification.
- 9.1.3 Welding electrodes shall be stored and handled in accordance with the manufacturers recommended practice.
 1. Electrodes should be stored in sealed original metal containers until ready for use.
 2. Those in opened containers should be protected from deterioration and excessive moisture changes.
 3. Visual inspection of the electrodes should be done prior to and during welding.
 4. Electrodes that show surface oxidation, fractured coatings, or eccentricity of the coating with respect to the electrode core wire should be discarded.
 5. See other electrode discussion under [Subsection 7.3](#).

9.2 Line-Up and Fit-Up of Butt Welds

- 9.2.1 External line-up or internal clamps should be used to ensure proper alignment for butt welds greater than 2" nominal diameter, unless it is impractical due to dimensional differences (e.g., flange or fittings to pipe, fitting to flange). Then, the pipe will be firmly supported to prevent movement.

9.2.2 External line-up clamps (for butt welds) may be removed before the complete root bead is applied, provided the line pipe is not unduly stressed and it is securely supported, and tack welded.

1. Root bead segments shall be approximately equal length and spaced around the circumference of the joint.
2. When conditions make it difficult to prevent movement of the line pipe, or if the line pipe weld will be unduly stressed, then approximately 50% of root bead should be uniformly spaced around the circumference of pipe before line-up clamp is released or removed.

9.2.3 The clamps shall remove out-of-roundness and shall provide a uniform joint fit-up. High-low conditions on equal-wall thickness pipe should not exceed 3/32".

9.2.4 When an internal alignment clamp is used for achieving alignment, it shall be held firmly in position until the root pass is approximately 90% completed and line pipe has been properly supported.

9.2.5 Root opening shall have uniform spacing throughout circumference of the joint. The spacing shall be in accordance with the approved welding procedure.

1. Minor root opening adjustments are permitted after installation of a root-bead segment to maintain root-opening tolerances.
2. Adjustments to the root gap greater than 1/8" on weld assemblies is not allowed unless the root-bead segment is replaced.

9.3 Longitudinal Seam Offset

9.3.1 Longitudinal seams in adjacent lengths of longitudinal welded pipe shall be offset by a minimum of 2".

9.4 Miter Joints

9.4.1 A miter joint on steel pipe to be operated at pressure that produces a hoop stress of 30% or more of SMYS may not deflect the pipe more than 3 degrees.

9.4.2 A miter joint on steel pipe to be operated at pressure that produces a hoop stress less than 30% SMYS may not deflect the pipe more than 12-1/2 degrees. Further, it must be a distance equal to one pipe diameter or more away from any other miter joint, as measured from the crotch of each joint.

9.4.3 Wrought-steel welding elbows and transverse segments of these elbows may not be used for changes in direction on steel pipe that is 2" or more in diameter unless the arc length, as measured along the crotch, is at least 1".

1. Segment-able fittings should be used for dissecting fittings.

9.5 Weld Joint Bevels

9.5.1 Unless otherwise specified, AIC will supply pipe with beveled ends conforming to API 5L.

9.5.2 When re-beveling is necessary, it may be accomplished using a mechanized oxyacetylene beveling machine or an approved facing tool.

9.5.3 If approved by the AIC welder, a rust preventative such as deoxaluminat may be applied to the pipe bevels to prevent rust and corrosion during long-term storage.

9.6 Transition Joints

UNCONTROLLED IF PRINTED

- 9.6.1 The transition between pipe ends of unequal thickness shall be by mechanical tapering, or by welding in accordance with ASME B31.8 or by means of a fabricated weld transition fitting not less than 12" minimum or 1-1/2 pipe diameters in length. For weld transition fittings, see [STLP 3.1 Section 5.0](#).
- 9.6.2 See [Appendix A](#) for acceptable preparations for joining pipe ends by butt welding for materials having unequal wall thickness and/or SMYS, all in accordance with ASME B31.8, "Gas Transmission and Distribution Piping Systems."

9.7 Socket Weld Joining

- 9.7.1 Socket weld fitting shall initially be fully seated on the clean pipe end.
- 9.7.2 The end of the fitting shall be marked on the pipe.
- 9.7.3 The fitting shall be moved 1/16" to 1/8" away from the mark or an approved spacer ring installed between the mark and the fitting.
- 9.7.4 Socket weld fitting shall not be bottomed out when welding.

This space is needed for thermal expansion as the fitting is welded.

9.8 Weld Joint Cleaning

- 9.8.1 Clean the beveled weld joint and the inside and outside surfaces at the end of each pipe to be field welded for a minimum distance of 1" immediately prior to welding.
- 9.8.2 All traces of foreign material shall be removed by hand or using power tools. Scale and slag shall be removed after completing each pass.
- 9.8.3 The pipe ends shall be completely dry prior to and during field welding. This may be accomplished by using propane or oxy-acetylene torches with a "rosebud" tip regardless of ambient temperature.
- 9.8.4 The pipe and/or fittings must be free of moisture (outside or inside) prior to and during welding operation.

9.9 Welding Equipment

- 9.9.1 Welding equipment used for field welding shall be maintained in good working condition and have the same performance capabilities as used to qualify the welding procedure.
- 9.9.2 Any machine that is not performing satisfactorily shall be removed from service and replaced or repaired.
- 9.9.3 Machines used for certified welding will be inspected periodically for voltage, amperage, gas flow, and general integrity. Annual inspection can be performed by AIC personnel, inspectors, or welders.

9.10 Weld Ground Placement

- 9.10.1 Commercially available grounding clamps may be used for fabrication work and/or field construction as applicable.

The use of magnetic ground clamps or copper ground shoes is prohibited.

9.10.2 The ground shall be located in a manner (preferably on the cap of a completed weld) that prevents arc burns on the pipe.

1. DO NOT tack weld ground clamps to pipe or fittings.
2. During production welding (ref pipe gang), place the welding ground on the last finished or unfinished weld.
3. Grounds used for final line welding should be placed on the finished weld.

9.10.3 Arc burn damage on the pipe is not acceptable.

9.10.4 Arc burns on pipe or on completed welds shall be eliminated in accordance with [WELD 2.10](#), or cut-out as a cylinder if directed by the welding inspector.

9.11 Weld Joint Clearance

9.11.1 When the pipe is welded aboveground, a minimum clearance of 16" is recommended.

9.11.2 When the pipe is welded in the ditch, the bell hole shall be of sufficient size to provide the welding personnel with ready access to the joint for all welding operations.

9.12 Root Bead Segments

9.12.1 Root bead segments, which are to be incorporated into the final weld, shall be thoroughly cleaned of scale, and suitably prepared at each end by means of grinding to ensure complete stringer bead continuity.

9.12.2 Root bead segments shall be free of cracks.

9.13 Weld joint Protection

9.13.1 Welding shall not be performed when weather conditions exist that would be detrimental to the quality of the finished weld. Rain, snow, winds above 15 MPH (for SMAW), and moisture from any source, are known to contribute to unfavorable weld quality.

GMAW process cannot tolerate any wind (0 MPH).

9.13.2 Welding may continue during inclement weather only after adequate shelters and precautions are implemented to ensure proper weld protection.

9.13.3 The AIC weld inspector shall determine if the protective measures are adequate prior to welding.

9.14 Weld Pass Requirements

9.14.1 A minimum of 2 complete weld passes shall be made prior to leaving weld in the unfinished condition. This requirement is to ensure weld cracking will not occur.

- 9.14.2 Depending on the pipe wall thickness and/or weld stress level, the AIC welder may require additional passes be made prior to leaving the weld temporarily unfinished.
- 9.14.3 Unfinished welds that have cooled should be preheated to between 200 °F and 500 °F prior to completion.
- 9.14.4 Maximum time for unfinished welds should be as soon as possible, not to exceed 72 hours.

9.15 Preheating Welds

- 9.15.1 Preheating of welds shall be in accordance with the approved welding procedures. A minimum 200 °F (maximum 500 °F) preheat is required when the ambient temperature is below 50 °F.
- 9.15.2 Heating might be required to remove moisture from the welding region, a minimum of approximately 2" on each side around the joint, prior to welding.
- 9.15.3 Temperature readings shall be taken using temperature indicating crayons or pyrometers (direct reading or infrared). Measurements shall be made at 4 locations 90 degrees apart on each side of the weld joint. The location shall be 2" from the weld centerline.

9.16 Inter-pass Cleaning and Removal of Visual Defects

- 9.16.1 Each pass of the weld metal shall be cleaned of slag or remaining flux using hand or power tools with wire wheels before a further pass is applied.
- 9.16.2 Visible defects, such as slag cavities, cold laps, and other deposition faults, shall be removed by grinding.
- 9.16.3 Clusters of surface porosity and high points shall be removed by grinding prior to deposition of the next pass.

9.17 Filler and Finished Beads

- 9.17.1 The completed weld shall have a uniform cross-section around the entire circumference.
- 9.17.2 At no point shall the weld crown (cap pass) surface be below the outside surface of the pipe, nor should it be above the parent metal by more than 1/16". However, the height of a weld crown may exceed 1/16" if the contour provides a uniform transition into the pipe material on both sides of the weld. Maximum height is 1/8" with a smooth contour.
- 9.17.3 Two beads shall not be started at the same location, and the face of the completed weld should be approximately 1/8" greater than the width of the original groove.
- 9.17.4 The completed weld shall be thoroughly brushed, cleaned, and inspected.

9.18 Weld Stripper Passes

- 9.18.1 A stripper pass may be used to eliminate external conditions such as external undercut or incomplete fill of a cap pass.
- 9.18.2 Stripper passes, when used, shall be minimum 2" in length, and a minimum of an electrode diameter in width.
- 9.18.3 Prior to welding a stripper pass on a weld that has cooled to ambient temperature, the area to be welded shall be preheated from a minimum of 200 °F to a maximum of 500 °F for a distance of 3" on each side of the weld.

UNCONTROLLED IF PRINTED

9.19 Back-Welding

9.19.1 When pipe and/or a fitting size permits access to the inside surface, back-welding may be used to eliminate unacceptable internal conditions or to complete the weld on transitions or fittings to pipe.

9.19.2 Prior to back-welding, the area shall be preheated from the outside to achieve a preheat temperature on the inside surface from a minimum of 200 °F to maximum of 500 °F. This preheat applies to all areas of back-welding.

9.20 Arc Burns (49 CFR 192.309(c))

9.20.1 Arc burns shall be eliminated in accordance with the approved arc burn removal procedure. See [WELD 2.10](#), Arc Burn Removal.

9.21 Pipe Coating Protection

9.21.1 The pipe coating, if applicable, on pipe 8" nominal diameter and larger should be protected from weld spatter and mechanical abrasion during welding.

9.21.2 If weld spatter is observed on smaller than 8" pipe, the pipe coating should be covered for protection before proceeding.

9.22 Tie-In Welds

9.22.1 Once started, tie-in welds shall be completed without interruption.

9.23 Identification of Welders

9.23.1 Each welder should mark the weld or section of weld for which he has been responsible. AIC welders may use their employee number. Contract welders may use their initials, last 4 digit of SSN, or welder qualification employee number.

9.23.2 The ID marking will be done with a weatherproof contrasting color permanent ink or paint marker.

10.0 Weld Repairs

10.1 Depending on extent of defective weld areas found during visual or nondestructive examination, the weld may be repaired or cut-out as a cylinder of pipe in accordance with the following limits:

10.1.1 Repairs shall use the original welding procedure or an approved AIC repair procedure.

10.1.2 Cracks, regardless of their location, shall be cut-out as a cylinder unless a repair is performed following the appropriate WPS and is approved by the AIC welder supervisor or in a manner acceptable to the welding inspector.

10.1.3 Defects, except cracks, found by visual examination, magnetic particle, or liquid penetrant that are externally exposed in the cover pass may be repaired.

10.1.4 Defects found by visual or nondestructive examination (e.g., slag inclusions, porosity, gas pockets) may be repaired in compliance with API 1104 provided the defects can be removed without grinding completely through the weld.

10.1.5 Defects, which require removal of the root pass, require approval of the AIC welding inspector.

10.2 Before the above repairs are made, the defective area shall be entirely removed to clean metal by grinding.

10.2.1 All slag and scale shall be removed by wire brushing.

10.3 All repair cavities shall be at least 2" in length and repaired with a minimum of 2 passes.

10.3.1 The start and stop points of repair passes shall not be superimposed over the start and stop of the preceding pass.

10.3.2 The start and stop of each repair pass shall be ground smooth.

10.4 Prior to repair welding, a minimum of 2" on each side of the repair area shall be pre-heated to a temperature from a minimum of 200 °F. to a maximum of 500 °F and maintained during welding. Temperature shall be checked by temperature indicating crayons or pyrometers (direct reading or infrared).

10.5 All repairs shall first meet visual acceptance and then meet the Acceptance Standards for Nondestructive Testing in API 1104.

10.6 The qualified welder assigned to perform the specific task is responsible for identifying the correct welding procedure for the pipe grade, outside diameter, and wall thickness.

10.7 When welding on pipe diameters of 16" or greater, 2 welders should be used to complete the root bead and hot pass. Then, 1 welder can complete the filler and cap passes.

10.7.1 On pipe diameters less than 16", one welder may be used.

11.0 Weld Inspection

11.1 Recommended Non-Destructive Testing (NDT) Methods

11.1.1 AIC recognizes there are several NDT methods available for field inspection of fillet and groove welds for new construction.

11.1.2 Table 2 shows the current NDT recommendations by AIC for each type of weld. (As NDT methods and technology change or improve, the table will be revised accordingly.)

Table 2: Recommended NDT Methods

Weld Type / Joint Design	NDT METHODS		
	Radiographic	PT or LPT	MT or MPT
Groove Butt Welds	R		
Fillet Welds		A	R
Legend: PT or LPT = Liquid Penetrant Testing MT or MPT = Magnetic Particle Testing R = Recommended A = Alternate Method			

11.2 Visual Weld Inspection

11.2.1 Visual inspection of welds will be conducted to ensure that welding is performed in accordance with WPS and that welding meets the requirements of this specification and the Acceptance Standards for Nondestructive Testing in API 1104. See [WELD 2.5](#).

11.3 Radiographic Inspection

11.3.1 When conducting radiographic examination of butt welds, it shall meet the requirements in 49 CFR Part 192. At the option of AIC, the extent of radiographic examination may exceed these requirements to assure quality welding is being achieved throughout the project. See [WELD 2.6](#).

11.3.2 Unless specified otherwise, the standard of acceptability for interpretation of radiographic film or digital image for all regulated pipeline or piping system welds shall be the Acceptance Standards for Nondestructive Testing in API 1104.

11.4 Production Weld Qualification

11.4.1 At the discretion of the qualified AIC representative, production welds may be cut-out and tested to confirm the adequacy of the welding procedure under construction conditions. Financial accountability will be:

1. Welds meeting the requirements of API 1104 will be charged to AIC.
2. Those welds not meeting the requirements of API 1104 will be charged to the pipeline contractor.

11.5 Disqualification of Welders

11.5.1 A welder who makes a weld that fails to comply with these requirements may be disqualified from further welding at discretion of the qualified AIC representative.

12.0 Records

12.1 For records required and retention, see [WELD 2.6. Section 10.0](#).

End of Instructions.

Operator Qualification (OQ) Required?

YES

0801: Welding

0811: Visual Inspection of Welding and Welds

1071: Repair of Steel Pipe by Grinding

Appendices

[Appendix A - Joining Unequal Steel Wall Pipe and Fittings](#)

Attachments

NONE.

Compliance Requirements

49 CFR Part 192 - Transportation of Natural and Other Gas by Pipeline: Minimum Federal Safety Standards

American Petroleum Institute (API), Std 1104, "Standard for Welding Pipelines and Related Facilities", with Appendix B, "In-Service Welding"

American Society of Mechanical Engineers (ASME) B31.8, "Gas Transmission and Distribution Piping Systems"

Illinois Commerce Commission (ICC) Title 83: Public Utilities, Part 590, Minimum Safety Standards for Transportation of Gas and for Gas Pipeline Facilities, available online [here](#).

Reference Documents

AIC Form Welding Procedure Qualification Report (WPQR)

[REPR 1 Repairs: Requirements](#)

UNCONTROLLED IF PRINTED

STLP 3.1 Steel Pipe: Weld Fittings

WELD 1 Welding: Requirements

WELD 2.2 Welding: Welder Qualifications

WELD 2.5 Welding: Visual Inspection

WELD 2.6 Welding: Radiographic Testing

WELD 2.10 Welding: Arc Burn Removal

WELD 4 Welding: Forms and Reference Materials

American Welding Society (AWS) A5.1, "Specification for Carbon Steel Electrodes for Shielded Metal Arc Welding."

American Welding Society (AWS), A5.5, "Specification for Low-Alloy Steel Electrodes for Shielded Metal Arc Welding."

Document Rescission

WELD 2.3 Welding: Construction of Pipelines, October 1, 2020

Revision Notes

Location of Changes	Summary of Changes
Paragraph 9.16, Item 3	Remove the requirement to grind starts and stops in the inter-passes. Inter-passes starts and stops can be cleaned with hand or power tools with wire wheels.
Revision Notes	Updated – WELD 2.3 Welding: Construction of Pipelines.

Appendix A - Joining Unequal Steel Wall Pipe and Fittings

A-1. This appendix is to illustrate acceptable preparations for joining pipe ends by butt welding materials having unequal wall thickness and/or SMYS, all in accordance with ASME B31.8, "Gas Transmission and Distribution Piping Systems."

A-1.1 When the SMYS of the material sections to be joined are unequal, the deposited weld metal shall have mechanical properties at least equal to those of the section having the higher strength.

A-1.2 The transition between ends of unequal thickness may be accomplished by taper or welding as illustrated below or by means of a prefabricated transition fitting.

A-1.3 Sharp notches or grooves at the edge of the weld where it joins a slanted surface shall be avoided.

A-1.4 Where joining sections of unequal thickness but equal SMYS, there is no minimum angle limit to the taper.

A-1.5 The maximum thickness (tD) for design purposes (i.e., MAOP calculations), shall not be greater than 1.5 times the wall of the thinner pipe (t).

A-1.6 Unequal Internal Diameters (Internal Offset)

A-1.6.1 If the nominal wall thickness of the adjoining pipe ends does not vary more than $3/32$ " , no special treatment is necessary. Full root penetration and bond is required in welding.

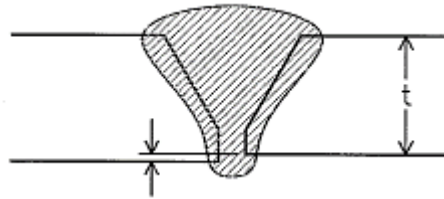

$3/32$ " maximum

A-1.6.2 Where the nominal internal offset is greater than $3/32$ " , the transition must be made by a taper cut on the inside of the thicker section. The taper angle shall not be greater than 30 degrees nor less than 14 degrees.

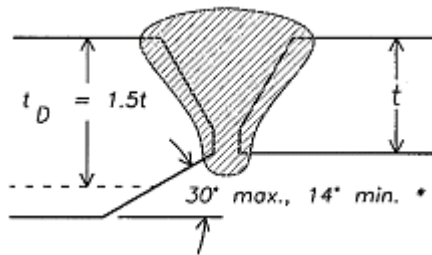

* Note: No minimum angle when the pipes have equal yield strengths.

A-1.7 Unequal External Diameters (External Offset)

A-1.7.1 Where the external offset does not exceed $1/2$ the thinner section, the transition may be made by welding provided the angle of rise of the weld surface does not exceed 30 degrees and both bevel edges are properly fused.

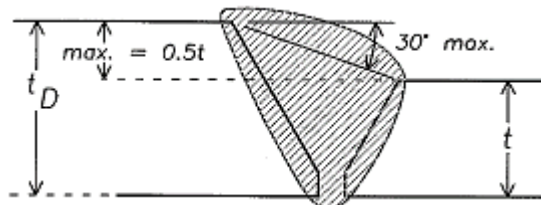

A-1.7.2 Where the external offset exceeds $1/2$ the thinner section, that portion of the offset over $0.5t$ shall be tapered not less than 14 degrees and not more than 30 degrees.

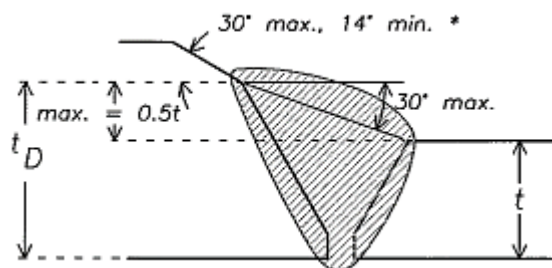

* Note: No minimum angle when the pipes have equal yield strengths.

A-1.8 Unequal Internal and External Diameters (External and Internal Offset)

A-1.8.1 Where there is both an internal and an external offset, the joint design shall be such that both the external portion of the offset over $0.5t$ and the internal offset of more than $3/32$ " is tapered not less than 14 degrees and not more than 30 degrees.

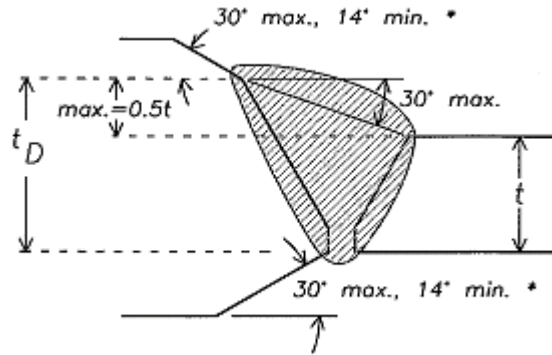

* Note: No minimum angle when the pipes have equal yield strengths.

End of Appendix.

WELDING

WELD 2.4 In-Service Welding

1.0 Purpose

This document establishes the requirements for in-service welding and inspection of pressure piping systems for Ameren Illinois (AIC). It is in accordance with 49 CFR Part 192.

2.0 Scope

This document addresses the following:

[3.0 Target Audience](#)

[4.0 General](#)

[5.0 Material Requirements](#)

[6.0 Acceptable Repair Methods](#)

[7.0 Welder Qualification](#)

[8.0 Welding Procedures](#)

3.0 Target Audience

- Gas Tech Engineering (GTE)
- Gas Integrity Management Personnel
- Gas Engineers
- Gas Superintendents
- Gas Supervisors
- Gas Field Personnel - Welders
- Gas Construction Services Superintendents
- Gas Construction Services Supervisors
- Gas Contract Welding Inspectors
- Contract Gas Construction Company Supervisors
- Contract Gas Construction Company Welders
- Contract NDT Personnel

4.0 General

- 4.1 *In-service welding* is any welding performed on a pipeline or pressure piping system that contains gas (or any liquid) under static or flowing conditions.
- 4.2 Burn-through and hydrogen-induced cracking are major concerns when performing in-service welding.
- 4.3 AIC accepts the methods discussed herein for the repair of piping systems. Further, all repairs on gas piping systems shall be done in accordance with the Repairs section of the O&M Plan. See [REPR 1](#).
- 4.4 Welding on lines that are under internal pressure shall be done in strict conformance with the AIC O&M Plan and the approved AIC welding procedures.

5.0 Material Requirements

- 5.1 All materials used for in-service welding, such as sleeves and fittings, shall meet the minimum design requirements for wall thickness plus yield and tensile strength as specified by the welding procedure.
- 5.2 Backing strips should be a low-carbon material (e.g., 1010, 1020 carbon mild steel).

6.0 Acceptable Repair Methods

6.1 Pipe Replacement

- 6.1.1 If practicable due to available downtime, the preferred option is to replace the defect area by cutting out a cylindrical piece of pipe and replacing it with new pipe.
- 6.1.2 For repair purposes, a "cut-out cylinder" should be the minimum length as outlined below. See [REPR 1, Subsection 6.1](#).
 1. Size 2" through 8" nominal diameter: minimum 12".
 2. Greater than 8" nominal diameter: minimum of 1.5 times the nominal pipe diameter.

6.2 Full Encirclement Sleeves

- 6.2.1 Complete encirclement using split sleeves can be used for the repair of leaking welds, unacceptable welds, dents, corrosion, or pipe leaks. See [REPR 1, Subsection 6.3](#), Welded Full-Encirclement Split Sleeve.
- 6.2.2 The sleeve material shall provide the same pressure capability (or greater) as the carrier pipe.
- 6.2.3 All full-encirclement sleeves applied to repair leaks shall be fully welded both longitudinally and circumferentially in accordance with the Welding Sequence procedures. See [Subsection 8.4](#).
- 6.2.4 Full-encirclement sleeves that require "In-Service" welding procedures should be fitted with a low-carbon backing strip (e.g., 1010 /1020 carbon (18 gauge), 0.043 inch thick mild steel (approx. 1 inch wide)) under the longitudinal seams that contact the carrier pipe.

This is to prevent arcing or welding to the carrier pipe in the hoop stress direction.

1. Steel banding/strapping shall not be used for backing strips.

6.3 Hot Tap Fittings

- 6.3.1 When installing full-encirclement fitting, use backing strips whenever possible. A root opening of 1/16" to 3/16" shall be maintained on both longitudinal seams of the split fitting.
 1. The backing strip shall be of the same or comparable chemical composition to the material being welded.

Exercise *extreme caution* when welding the longitudinal weld to prevent burning through the backing strip and welding or arcing to the carrier pipe.

- 6.3.2 The hot tap fitting shall **not** be located within 2' of a pipe anchor, girth weld, flanged connection, or threaded connection unless approved by the Welding Supervisor.

- 6.3.3 The carrier pipe and the fitting shall be sand blasted or mechanically cleaned of all coating, scale, paint, or other foreign material. Cleaning shall be at least 3" on either side of the welding area.
- 6.3.4 Tapping in a girth weld is not permitted.
- 6.3.5 If the tap is through an area containing a longitudinal seam on pipe listed below, the area shall be ultrasonically analyzed for 10" beyond the fillet weld at the ends of the fitting. The weld shall meet the acceptance standards of API Std 1104.
 - 1. All transmission pipe, AND
 - 2. High pressure distribution pipe 4" and larger with MAOP of 100 psig or greater.

Gas Tech Engineering or Integrity Management may request an alternative method for analyzing the seam.

- 6.3.6 All hot tap fittings and other pressure containing fittings shall be leak tested in accordance with [PTST 1, Section 10](#), Testing after:
 - 1. Completing the welding, but before cutting the hot tap, and
 - 2. After tapping, soap test the weld at line pressure.

7.0 Welder Qualification

- 7.1 All in-service welding personnel using In-Service welding procedures shall be qualified in accordance with [WELD 2.2](#), which includes the requirements of, API Std 1104, Appendix B, "In Service Welding".

8.0 Welding Procedures

8.1 General

- 8.1.1 All in-service welding with operating pressures greater than 100 psig shall comply with the requirements of this specification or API 1104, Appendix B.
- 8.1.2 The in-service welding procedure specification (WPS) to be used will be those contained in [WELD 4](#) and designated with the "IS" prefix, unless specified otherwise.

8.2 Wall Thickness Survey

- 8.2.1 Prior to any in-service welding or installation of a fitting to be used to tap the lines listed below, the area to be welded shall be ultrasonic tested (UT) for laminations, internal corrosion, and inclusions. See [WELD 2.9](#).
 - 1. All transmission lines.
 - 2. High pressure steel distribution mains of 4 inch and larger with MAOP of 100 psig or greater.
- 8.2.2 The minimum wall thickness for 4" and larger carrier pipe that may be welded is 0.188", unless otherwise approved by the AIC Welding Supervisor.
- 8.2.3 The UT survey, shown in [Figure 1](#), shall be made around the entire circumference of the pipe, 3" either side of where circumferential fillet welds will be made.

- 8.2.4 For hot taps or side tap shaped nipples, the UT survey shown in [Figure 2](#) shall include the area to be tapped and 3" around the outside area of the branch connection.
- 8.2.5 Recommended UT approach is to perform inspection with one person moving probe and a second person reading and recording the data.
- 8.2.6 Any area that appears to indicate wall thickness defects are present shall be further evaluated by AIC personnel.

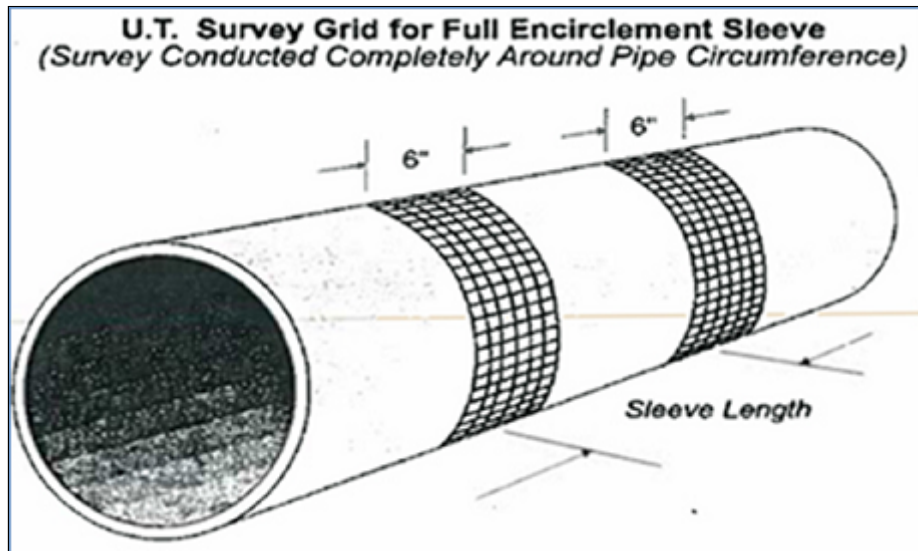

Figure 1: UT Survey - Full Encirclement

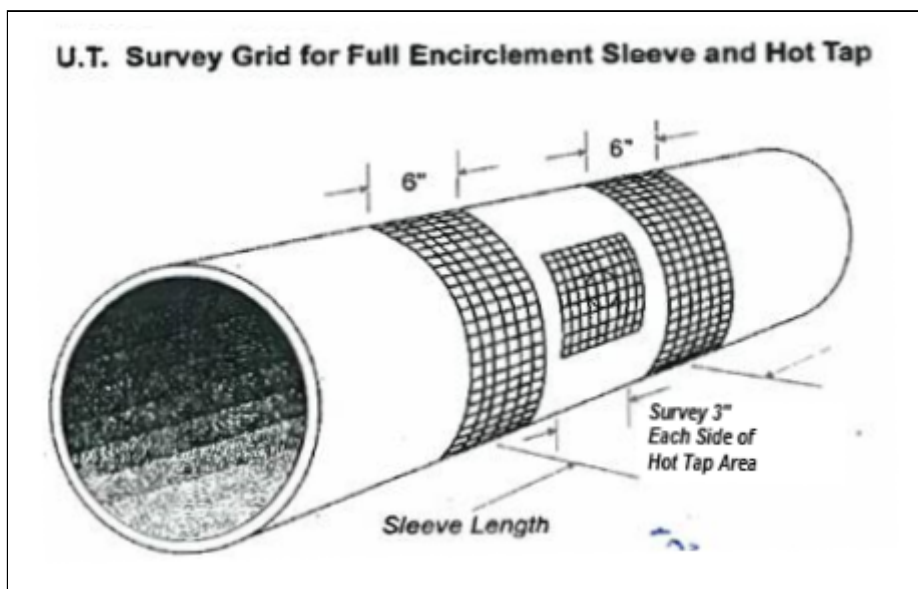

Figure 2: UT Survey - Full Encirclement with Hot Tap

8.3 In-Service Welding Electrode Requirements

- 8.3.1 The welding procedures approved for pipeline maintenance on the following AIC piping systems shall require a check for HIGH-flow (indicating rapid cooling, thus quenching the base metal):
 1. Pipe 4" nominal diameter and larger,
 2. Operating above 100 psig, AND

3. Older than 1975 (being high-carbon equivalence).

- 8.3.2 Preheat the pipe weld region between 400 °F to 500 °F for 3" both sides of the weld area. If this area cools below 200 °F within 4 minutes, this would indicate HIGH flow and the weld must be made with an AIC In-Service Welding Procedure IS01.
- 8.3.3 In-service welding requires using low hydrogen welding electrodes (specifically E 7018 H4R) and an additional Welder Qualification test specific to the Welding Procedure.
- 8.3.4 E7018-H4R are the preferred electrodes but if the pipe weld area remains hot without additional heating, then the welder may use Cellulose or "Gas Metal Arc Weld (GMAW)" procedures appropriate to the base material.
- 8.3.5 Pipelines that have been depressurized or purged to 0% gas may be welded using cellulosic and GMAW electrodes.
- 8.3.6 Storage and handling of low hydrogen electrodes shall be as described by the manufacturer. As a minimum requirement, all low hydrogen electrodes for use with in-service pipe welding shall be stored in rod ovens at temperature between 250 °F and 350 °F after they have been removed from their sealed container.
- 8.3.7 Low hydrogen welding electrodes found in "under-temperature" ovens (below 250 °F) will be painted yellow and discarded. Open new electrodes and store in a properly heated electrode oven.
- 8.3.8 Any electrodes which have been exposed to moisture or which are of a questionable condition shall not be used for pipeline in-service welding applications.
- 8.3.9 Welding full encirclement fittings (i.e., Style 110, 220 and Mueller full-encirclement control fitting) should utilize backing strips when using an "In-Service" welding procedure. See [Subsection 6.2](#).

8.4 Welding Sequence

All welding of full encirclement sleeves or fittings shall be done following the requirements of the applicable AIC welding procedure. The sequence follows:

- 8.4.1 Complete the UT survey at the areas to be fillet welded, if necessary. If survey indicates the pipe does not meet minimum wall thickness tolerances of API 5L, locate another area that conforms to the thickness tolerance prior to welding. As stated in UT Survey (see [Paragraph 8.2.2](#)), 0.188" is the minimum wall thickness to be welded without approval from the AIC welding supervisor.
- 8.4.2 Vent holes (typically 1/4") may be utilized for venting leaking gas.
1. An appropriate weld fitting, such as nipple or weld-o-let, could be welded over the vent hole to which a vent stack can be attached.
 2. The weld fitting and vent stack shall be constructed with pressure rated materials compatible with the maximum operating pressure of the pipe being repaired.
 3. Following completion of the repair, insert and weld a steel plug/cap in the fitting to prevent removal.
 4. The top vent hole should be welded last to vent superheated welding fumes.
- 8.4.3 Place the top and bottom sleeves or fittings with the backing strips tacked in the weld region of the bottom sleeve/fitting over the carrier pipe area.

- 8.4.4 Clamp or hold the sleeves/fittings in place, maintaining the proper weld root spacing for the longitudinal welds. Tack weld sleeves and backing strips together at the ends and center in the longitudinal grooves.
- 8.4.5 **DO NOT** tack weld sleeves to the carrier pipe (prohibited).

Note that welding the longitudinal groove welds results in weld shrinkage of the sleeve or fitting around the carrier pipe.

- 8.4.6 Give allowance during fit-up for shrinkage of 1/16" to 3/32" across the diameter of the sleeve during welding of the longitudinal groove welds. Recommend using a feeler gauge to measure.
- 8.4.7 After tacking the sleeves/fittings, complete the longitudinal welds on both sides (weld the longitudinal welds equally or use 2 welders simultaneously if available).
 - 1. Exercise care to ensure the longitudinal welds do not fuse to pipe at the ends of sleeve. The backing strip ensures that the longitudinal welds does not penetrate the carrier pipe.
 - 2. Refer to the procedure for proper sequence of the weld passes.
 - 3. See WPS IS 01 for special heating requirements for fittings that are wall thickness of 1.25 inch or greater.
- 8.4.8 With the longitudinal (side) welds completed, allow for cooling (shrinkage), then complete the lap-fillet weld on 1 end of the sleeve/fitting This allows the sleeve/fitting to move or shrink toward the welded end. Refer to the procedure for proper sequence of weld passes.
- 8.4.9 When the first end has been completely welded and cooled to ambient and/or line temperature, weld the last end to completion. Refer to the procedure for proper fillet weld size and proper sequence of weld passes.
- 8.4.10 Visually examine the longitudinal groove welds and circumferential fillet welds. When code requires or engineer requests, non-destructive inspection should be done in accordance with [WELD 2.7](#) - Magnetic Particle Testing (MPT) or [WELD 2.8](#) - Liquid Penetrant Testing (LPT).
- 8.4.11 If the fitting is being exposed to operating pressure, check the fitting with leak detection fluid or leak detection instrument as required before coating.
- 8.4.12 Protectively coat the sleeve/fitting with an approved coating. See [CORR 2.3](#).

8.5 Arc Burns

- 8.5.1 Arc burns on pipelines operating at or above 40% SMYS shall be cut-out as a cylinder, or at the discretion of the welding inspector may be eliminated in accordance with [WELD 2.10](#).
- 8.5.2 For removal of arc burns on other pipelines, see [WELD 2.10](#). The manner and extent of removing metal can be critical (i.e., must maintain minimum wall thickness).

8.6 Inspection Requirements

8.6.1 Fillet Welds

1. *Visual inspection* (mandatory requirement for all welds) in accordance with [WELD 2.5](#).
2. *Magnetic Particle Testing (MPT)* is the preferred NDT process. See [WELD 2.7](#).
3. *Liquid Penetrant Testing (LPT)* is an alternate to MPT. See [WELD 2.8](#).
4. Any crack or defect that has the appearance of a crack-like indication may be cause for rejection.

8.6.2 Longitudinal Groove Welds

1. During fit-up of the sleeves/fittings to the carrier pipe, conduct visual inspection to ensure the proper placement of the backing strips behind the groove weld.
2. In addition to visual inspection of welds, the inspection of longitudinal groove welds on full encirclement sleeves/fittings may be done using the preferred MPT process. If necessary, the LPT process is an acceptable alternative to MPT.
3. Any crack or defect that has a crack-like appearance shall be rejected.

8.6.3 Test Time Period

1. After completing the in-service weld, allow time for the weld to cool to ambient and/or line temperature prior to conducting any non-destructive test. The longer the time after completing weld, the greater the chance of detecting a crack in the weld if one might exist. When possible, 24 hours is desired.

End of Instructions.

Operator Qualification (OQ) Required?

Yes

0801: Welding

0811: Visual Inspection of Welding and Welds

1051: Fit-Up of Weld Type Repair Sleeve

1071: Repair of Steel Pipe by Grinding

Appendices

NONE.

Attachments

NONE.

Compliance Requirements

49 CFR Part 192 - Transportation of Natural and Other Gas by Pipeline: Minimum Federal Safety Standards

American Petroleum Institute (API) API-5L, "Specification for Line Pipe"

American Petroleum Institute (API), Std 1104, "Standard for Welding Pipelines and Related Facilities", with Appendix B, "In-Service Welding"

UNCONTROLLED IF PRINTED

American Society of Mechanical Engineers (ASME) B31.8, "Gas Transmission and Distribution Piping Systems"

Illinois Commerce Commission (ICC) Title 83: Public Utilities, Part 590, Minimum Safety Standards for Transportation of Gas and for Gas Pipeline Facilities, available online [here](#).

Reference Documents

[CORR 2.3 Corrosion Control: Coatings](#)

[PTST 1 Pressure Testing: Requirements](#)

[REPR 1 Repairs: Requirements](#)

[WELD 2.2 Welding: Welder Qualifications](#)

[WELD 2.5 Welding: Visual Inspection](#)

[WELD 2.7 Welding: Magnetic Particle Testing](#)

[WELD 2.8 Welding: Liquid Penetrant Testing](#)

[WELD 2.9 Welding: Ultrasonic Wall Thickness Examination](#)

[WELD 2.10 Welding: Arc Burn Removal](#)

[WELD 4 Welding: Forms and Reference Materials](#)

American Welding Society (AWS), A5.5, "Specification for Low-Alloy Steel Electrodes for Shielded Metal Arc Welding."

Document Rescission

WELD 2.4 Welding: In-service Welding, October 1, 2020

Revision Notes

Location of Changes	Summary of Changes
Header.	Spelling correction – In-Service

WELDING

October 1, 2021

WELD 2.5 Visual Inspection

1.0 Purpose

This document establishes the visual inspection requirements for gas pipeline welding and welded gas systems for Ameren Illinois (AIC). It is in accordance with 49 CFR Part 192.

2.0 Scope

This document addresses the following:

[3.0 Target Audience](#)

[4.0 Inspection Requirements](#)

[5.0 Records/Reports](#)

[6.0 Inspection Equipment and References](#)

3.0 Target Audience

- Gas Tech Engineering (GTE)
- Gas Integrity Management Personnel
- Gas Engineers
- Gas Superintendents
- Gas Supervisors
- Gas Field Personnel - Welders
- Gas Construction Services Superintendents
- Gas Construction Services Supervisors
- Gas Contract Welding Inspectors
- Contract Gas Construction Company Supervisors
- Contract Gas Construction Company Welders
- Contract NDT Personnel

4.0 Inspection Requirements

4.1 General

- 4.1.1 Prior to conducting welding inspection on pipelines or piping systems, the welding inspector must have the knowledge of, and be familiar with, the industry codes, standards, and the AIC specifications that govern the respective construction activity.
- 4.1.2 The inspector should have access to the applicable codes and AIC welding procedures (WPS) in his possession for reference.
- 4.1.3 Welding inspector must have the appropriate inspection equipment on hand for determining compliance to the welding procedures and construction specifications. For inspection equipment, see [Section 6.0](#).
- 4.1.4 For compliance with AIC standard construction practices, **below are the primary areas that the welding inspector shall inspect and document.**

4.2 Welder and Procedure Qualification

- 4.2.1 The Welding Supervisor is required to check the qualification records for each welder working on AIC construction projects to ensure that current and proper qualification data is on file for the pipe diameters and wall thicknesses being welded. See [WELD 2.2](#) and [WELD 2.3, Section 6.0](#).

UNCONTROLLED IF PRINTED

4.2.2 Welding inspector shall examine the Welding Procedure Specification applicable to the project.

1. The Training Supervisor - Welding is required to ensure that the records of procedure test results are complete and accurate.

4.2.3 Any questions about the validity of AIC or contractor procedures for a particular application should be brought to immediate attention of the Training Superintendent-Gas Constructions & Operations.

4.3 Pipe/Component Surface Condition

4.3.1 The welding inspector shall examine the surface of all pipe and components for defects that might affect serviceability.

4.3.2 Any gouge, groove, dent, or other defect that exceeds the allowable depth in accordance with the applicable material standards must be removed by grinding or replacing the entire section as a cylinder.

4.3.3 After grinding to eliminate gouges or grooves, the wall thickness must be measured to ensure adequate wall thickness remains.

4.4 Alignment and Fit-up

4.4.1 Periodically ensure that the alignment and root space are in accordance with the approved AIC welding procedure (WPS).

4.4.2 Ensure the weld joint is clean and free of all foreign material, such as dirt, oil, and coating material.

4.4.3 Inspect end bevels for manufacturing defects, such as laminations, improper bevel angle, and improperly machined root face.

4.4.4 Check for handling defects, such as dent and root face damage.

4.4.5 Ensure the process / method of aligning pipe and components is done in a manner that does not result in abnormal residual stress on the completed weld.

4.4.6 For fillet welds, consider weld shrinkage that occurs. Require proper welding space with components being joined prior to welding.

4.5 Pipe Butt Welds

4.5.1 For diagram of the various butt weld passes, see Figure 1.

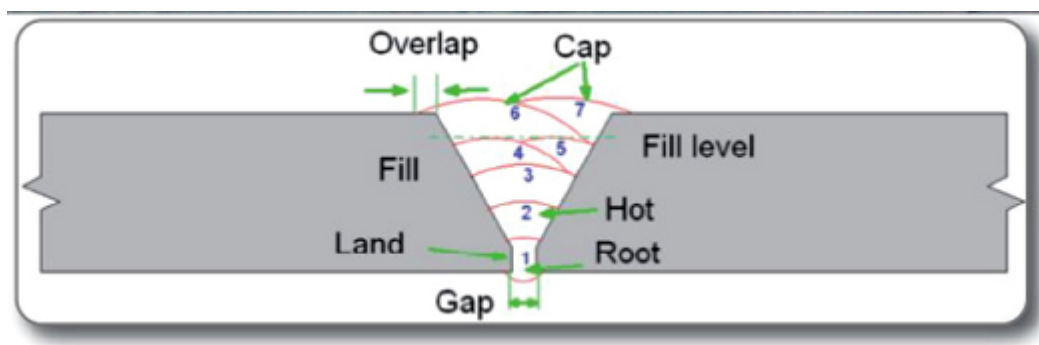

Figure 1: Various Welding Passes

4.5.2 Root Pass

1. When the welding procedure requires preheating, the temperature shall be measured by TempilStiks (see Figure 2 and [Paragraph 6.2.6](#)) or pyrometers

(direct reading or infrared). Preheating temperatures shall be maintained until completion of the root pass.



Figure 2: TempilStik -- Holder and Crayon

2. Check condition of the root pass electrodes and determine that the proper AWS classification and diameter are being used.
3. Examine the cable connections at the welding machine to verify that the correct polarity is being used.
4. During root pass welding, periodically verify that amperage, voltage, and travel speed comply with the approved welding procedure.

Recognize that root pass travel speed and amperage are closely related. Excessive travel speed usually indicates excessive amperage is being used and vice-versa. These being outside the procedure parameters increase potential for a thinner root bead possibly leading to cracking.

4.5.3 Hot Pass

1. Preheat when required.
2. Check condition of the hot pass electrodes and determine that the proper AWS classification and diameter are being used.
3. Ensure that the time period (major importance) is not exceeded between the root pass and the hot pass as specified in the approved welding procedure.
4. Periodically verify that amperage and voltage measurements are appropriate during deposition of the hot pass.
5. Require that the completed hot pass be cleaned of all slag by power brushing.
6. Ensure inter-pass temperature is not exceeded.

4.5.4 Fill Passes

1. Preheat if required.
2. Check condition of the fill pass electrodes and determine that the proper AWS classification and diameter are being used.
3. Confirm that the welding procedure is being followed regarding the number of fill passes for the respective wall thickness.
4. Periodically measured amperage and voltage to determine compliance with the approved AIC welding procedure. When checking voltage at the machine terminals, allow for a 2-3 volt drop at the arc depending on the length of the welding cable.

UNCONTROLLED IF PRINTED

5. Ensure that inter-pass cleaning is enough to eliminate slag-entrapment between passes.
6. Ensure inter-pass temperature is not exceeded.

4.5.5 Cap Pass

1. Preheat if required.
2. Check condition of the cap pass electrodes and determine that the proper AWS classification and diameter are being used.
3. Measure amperage, voltage, and travel speed on a periodic basis to determine compliance to the approved AIC welding procedure.
4. Ensure that the cap pass is properly cleaned, including the edges of the cap pass, so that a complete and thorough inspection can be performed.
5. Visual acceptance criteria for the finished weld, unless otherwise stated, shall be as follows:
 - 5 a. The weld crown (cap pass) surface shall not be below the pipe surface at any point, nor should it be above the parent metal by more than 1/16".
 - 5 b. Cap passes which are above the parent metal by more than 1/16" and which (per welding inspector opinion) may be suspect for having excessive re-enforcement may be ground down to 1/16" above the pipe surface. However, the height of a weld crown may exceed 1/16" if the contour provides a uniform transition into the pipe material on both sides of the weld. Maximum height is 1/8" with a smooth contour.
 - 5 c. Undercut at depth greater than allowed in Table 1 shall be repaired.

Table 1: Undercutting

Maximum Dimensions of Undercutting	
Depth	Length
> 0.032" or > 12.5% of wall thickness (WT), whichever is smaller.	Not acceptable
> 0.016" but ≤ 0.031" or > 6% WT OR ≤ 12.5% of pipe WT, whichever is smaller.	2" in a continuous 12" weld length OR 1/6th the weld length, whichever is smaller.
≤ 0.016" or ≤ 6% of pipe WT, whichever is smaller.	Acceptable, regardless of length

- 5 d. Two beads shall not be started at the same location, and the face of the completed weld should be approximately 1/8" greater than the width of the original groove.
- 5 e. Visibly porosity (pinholes) is not allowed. Porosity shall be removed by grinding. If the grinding reduces the cap below the pipe surface, the weld will be repaired following weld repair requirements.
 - 200 - 500°F preheat.
 - Weld length at minimum 2 inches.

- Steel Punches or peening the hole shut is not permitted.

5 f. Cracks of any length are not allowed and must be cut-out as a cylinder of pipe.

5 g. Arc burns on the weld or pipe are not allowed. For arc burns removal, see [WELD 2.10](#).

4.5.6 Pipe Fillet Welds

1. Inspect all fillet welds to ensure compliance with approved AIC welding procedure.
2. All fillet welds should have a minimum of 3 weld passes. (This requirement is to eliminate any potential leak path.) However, 3/4" punch tees can be with a 2-pass weld.
3. Unless otherwise specified, inspect fillet welds using the acceptance criteria listed below.
 - 3 a. Leg size shall be in conformance with approved procedure.
 - 3 b. Pinholes or porosity are not allowed.
 - 3 c. Undercut greater than 1/64" in depth is not allowed, regardless of length.
 - 3 d. Cracks of any length are not allowed. (See [Weld 2.3, Paragraph 10.1.2](#).)

5.0 Records/Reports

- 5.1 Develop and retain all visual inspection records and reports as appropriate for AIC compliance with this specification on a respective project basis.

6.0 Inspection Equipment and References

- 6.1 Visual inspection of pipe welding involves the use of certain instruments and inspection tools to measure pipe and components for conformance to AIC purchase specifications, welding parameters, and material defects. codes and standards.
- 6.2 Recommended equipment for the welding inspector includes the following (*plus additional optional equipment as needed*).
 - 6.2.1 Personal corrective glasses as needed.
 - 6.2.2 DC amperage meter (analog or digital) for measuring welding amperage (Tong meter, 0-200 amps).
 - 6.2.3 DC voltmeter for measuring arc welding voltage (DC Voltmeter, 100VDC).
 - 6.2.4 Dial or digital caliper (6") for accurate measurement of root face, pipe wall thickness at the ends, tensile specimens, etc.
 - 6.2.5 Pit measuring gage or dial indicator depth gage.
 - 6.2.6 Temperature indicating sticks (i.e., TempilStiks available at 150°, 200°, 250°, 300°, 350°, 400°, 450 °F.) or suitable pyrometer.
 - 6.2.7 Tape measure (6') for measuring length of weld deposit to assist in determining welding travel speed.

- 6.2.8 Stopwatch (or watch with a second hand) for measuring arc time of welding electrodes to determine travel speed during welding.
- 6.2.9 Ultrasonic Thickness Gage available onsite for measuring remaining wall thicknesses after a gouge or arc burn is removed.
- 6.2.10 Optional:
 - 1. "Pi" or diameter tape for measuring pipe ends to ensure conformance to API 5L or other pipe specifications.
 - 2. Gauss- meter with longitudinal probe available should a question arise regarding pipe possibly being magnetized. (Pipe could have magnetized by electromagnetic inspection methods or the pipe lifted with electromagnetics.) Knowing if pipe might be magnetized can help explain certain welding problems.
- 6.2.11 Fillet weld gauges.
- 6.2.12 Quality flashlight.
- 6.3 In addition to the above equipment, the welder and/or welding inspector is expected to have the applicable welding procedure specifications (WPS) on-site for immediate reference.
- 6.4 Added resources that should be readily accessible are the applicable codes and industry standards for reference.

End of Instructions.

Operator Qualification (OQ) Required?

YES

0811 Visual Inspection of Welding and Welds

Appendices

NONE.

Attachments

NONE.

Compliance Requirements

49 CFR Part 192 - Transportation of Natural and Other Gas by Pipeline: Minimum Federal Safety Standards

American Petroleum Institute (API), Std 1104, "Standard for Welding Pipelines and Related Facilities", with Appendix B, "In-Service Welding"

American Society of Mechanical Engineers (ASME) B31.8, "Gas Transmission and Distribution Piping Systems"

Illinois Commerce Commission (ICC) Title 83: Public Utilities, Part 590, Minimum Safety Standards for Transportation of Gas and for Gas Pipeline Facilities, available online [here](#).

Reference Documents

[WELD 2.2 Welding: Welder Qualifications](#)

WELD 2.3 Welding: Construction of Pipelines

WELD 2.10 Welding: Arc Burn Removal

Applicable Welding Procedure

American Society of Mechanical Engineers (ASME) B31.8, "Gas Transmission and Distribution Piping Systems"

Document Rescission

WELD 2.5 Welding: Visual Inspection, April 1, 2021

Revision Notes

Location of Changes	Summary of Changes
Reference Documents	Correction – ASME B31.8 – Gas Transmission and Distribution Piping Systems

WELDING

October 1, 2022

WELD 2.6 Radiographic Testing

1.0 Purpose

This document establishes the requirements for performing radiographic inspection of circumferential groove (butt) welds on all gas pipelines and gas piping systems made during construction or fabrication for Ameren Illinois (AIC). It is in accordance with 49 CFR Part 192.

2.0 Scope

This document addresses the following:

[3.0 Target Audience](#)[4.0 General](#)[5.0 Radiographic Testing Personnel](#)[6.0 Radiation Safety](#)[7.0 Radiographic Testing Procedures](#)[8.0 Radiographic Quality](#)[9.0 Production Radiography](#)[10.0 Reports](#)**3.0 Target Audience**

- Gas Tech Engineering (GTE)
- Gas Integrity Management Personnel
- Gas Engineers
- Gas Superintendents
- Gas Supervisors
- Gas Field Personnel - Welders
- Gas Construction Services Superintendents
- Gas Construction Services Supervisors
- Gas Contract Welding Inspectors
- Contract Gas Construction Company Supervisors
- Contract Gas Construction Company Welders
- Contract NDT Personnel

4.0 General

- 4.1 This procedure applies equally to maintenance/repair projects where the nature or involvement of welding work is like primary pipeline construction or related fabrication.
- 4.2 This specification does not apply to longitudinal groove (butt) welds and fillet welds made during in-service welding of full encirclement sleeves or patches.

5.0 Radiographic Testing Personnel

- 5.1 All Level I, Level II, or Level III radiographic testing (RT) personnel engaged in production and evaluation of radiographs for AIC shall provide AIC Gas Compliance with the following written documentation prior to production radiography:
 - 5.1.1 Certification or recertification by their employer in the Radiographic Testing method for the following:
 1. Previous 3 years as either a Level I or Level II, and

UNCONTROLLED IF PRINTED

2. Previous 5 years for Level III

NOTE:	A 5 years recertification interval for Level I, and Level II may be acceptable, if approved by AIC, for those NDT companies which conduct the additional required certification testing.
--------------	--

5.1.2 Documentation shall include the following minimum information:

1. Name of certified individual.
2. Level of certification (e.g., Level I, Level II, Level III).
3. Educational background and experience of certified individual.
4. Statement indicating satisfactory completion of training in accordance with employer's written practice.
5. Results of certification examination (grades).
6. Date of certification and/or recertification.
7. Certification expiration date.
8. Signature of employer's certifying person.

5.1.3 Certifications shall be in accordance with American Society for Nondestructive Testing, Recommended Practice No. SNT-TC-1A.

5.2 All other RT personnel (e.g., assistant radiographer/trainee) assigned to and engaged in assisting the Level II or Level III radiographer in the production of radiographs shall have a State of Illinois' Industrial Radiographer Certification Card

5.3 Vision Acuity Record

5.3.1 Current record of individual's near-vision acuity results administered by an approved medical professional to ensure natural or corrected near-distance acuity in at least one eye. This is to verify that individual can read a minimum of Jaeger Number 1 or equivalent type and size letter at a distance not less than 12".

5.3.2 Documentation of successful results from an administered color-contrast differentiation examination within the past 5 years.

5.4 All RT personnel engaged in the production and evaluation of radiographs for AIC shall maintain a copy of their certifications on the job site.

5.5 All requested information shall become part of the final job packet.

5.6 The AIC Project Engineer and/or Construction Inspector shall verify that RT personnel do have their current certifications.

5.7 Only Level II or Level III RT personnel shall:

5.7.1 Interpret radiographic images of production welds.

5.7.2 Report all defects observed in the images.

5.7.3 Indicate whether the weld meets the standard of acceptability as specified in the referencing code standard (i.e., API Std. 1104, Section 9).

5.8 RT personnel may be required to:

5.8.1 Demonstrate their ability to produce acceptable radiographs with each radiographic procedure they use prior to performing production radiographs.

5.8.2 Be recertified at the option of AIC or if any question arises about their ability. Level II or III RT personnel and film interpreter's work will be subject to review by AIC representative and any pattern of inconsistency will be cause for additional training, testing, or dismissal.

5.9 AIC shall have the right to remove any RT personnel who, in the opinion of the AIC representative, is incompetent, careless, unsafe, or otherwise not qualified to perform the work assigned, or who is found to be insubordinate or guilty of improper conduct.

6.0 Radiation Safety

6.1 All RT personnel engaged in the production of radiographs for AIC shall possess a current "Radiation Safety ID Card" issued by an authorized radiation safety regulatory jurisdiction.

6.2 When production requires a 3-man crew, the crew shall consist of a Level II/III, Level I, and a trainee as a minimum.

6.3 The lead radiographer (RT Level II or Level III) assigned to the job site shall be responsible for protection and monitoring of every person working with or near sources of radiation. This protection and monitoring must comply with applicable federal, state, and local regulations that apply to radiation safety.

6.3.1 No radiographer or their assistants may perform radiography without a film badge, pocket dosimeter, and properly calibrated and operable radiation survey instrument and rate alarm meter. This monitoring equipment must be acceptable to the AIC Welding Inspector.

6.4 Appropriate radiation warning signs shall be posted whenever radiographic examinations are taking place. In addition to visual surveillance by the RT personnel, radiation safety barriers, cones, ropes, or tape may be used to keep unauthorized individuals away from radiation areas.

7.0 Radiographic Testing Procedures

7.1 General

7.1.1 This section prescribes the minimum requirements for establishing and qualifying the radiographic procedures to be used for examination of welds covered by this section

7.1.2 Procedures should be qualified and approved whenever there is a change in an essential variable.

7.1.3 The required radiographic testing of welds shall be performed on pipe that is uncovered, accessible, and not coated with any material that would interfere with radiographic testing.

7.1.4 Weld shall meet the visual inspection criteria prior to being radiographed.

7.2 Procedure Qualification

7.2.1 Procedures to be used on the work assignment should be qualified/approved by AIC prior to the performance of any radiographic examination.

7.2.2 An approved radiographic shot (to prove qualified/detailed procedure) should be documented and attached to the radiographic report

1. The procedure shot can be the first production shot and should be documented by placing "P" after the weld number on the film or other imaging media.

2. Any changes in details contained in API Std 1104, Section 11.1.2.2 Film Radiography (20th Edition), require a new procedure shot. Details may include:
 - 2 a. Radiation source.
 - 2 b. Intensifying screens.
 - 2 c. Film.
 - 2 d. Exposure geometry.
 - 2 e. Exposure conditions.
 - 2 f. Processing method.
 - 2 g. Material being tested.
 - 2 h. Image quality indicators (IQI).
 - 2 i. Heat shields.
- 7.2.3 An AIC representative may be allowed to witness the test and determine acceptance of the procedure.
 1. Advanced notice must be given to AIC to schedule personnel for witnessing the procedure qualification.
- 7.2.4 The radiographer performing the radiographic test will be simultaneously qualified in the procedure.
- 7.2.5 Qualified procedures may be used by other radiographers from the same contractor provided they have a copy of the procedure record and they qualify their ability to produce an acceptable radiograph using the procedure details.

8.0 Radiographic Quality

- 8.1 The radiographic images produced by gamma ray or x-ray using the qualified procedure(s) shall have appropriate radiographic density, clarity, and contrast as required by the referencing code standard (i.e., API Std. 1104).
 - 8.1.1 Gamma ray shall use Class 1 film as follows:
 1. For pipe 6" nominal diameter and larger: D2 thru D5 film.
 2. On pipe less than 6" nominal diameter: D2 thru D4 film.
- Since most radiographic examinations performed at AIC are gamma ray, Class I film will be predominately used. Alternative film may be used with written approval by AIC approved third-party Level III technician.
- 8.1.2 X-Ray shall use Class 1 film or better or other imaging media. Alternative film may be used with written approval by an AIC approved third-party Level III technician.
- 8.2 The following criteria shall be used to evaluate radiographic images:
 - 8.2.1 An acceptable image quality that is free from fog and from processing irregularities that could mask the image of actual imperfections.
 - 8.2.2 The prescribed image quality indicator (IQI) and the essential wire diameter.

- 8.2.3 A satisfactory identification system.
- 8.2.4 An acceptable technique and setup.
- 8.2.5 Compatibility with referenced code acceptance standards.
- 8.3 The lead radiographer (RT Level II or Level III) assigned to the job site shall be equipped with a densitometer based on the H&D density measuring system and an enclosed high intensity viewing light.
- 8.4 The viewing light and the densitometer must meet the requirements as specified in Paragraphs [9.4.5](#) and [9.4.6](#), respectively, and shall be acceptable to the Welding Inspector.
- 8.5 All radiographic film images shall be examined with the aid of high intensity light and compliance with film density requirements as specified in the referenced code standard (i.e., API Std. 1104) and confirmed using the densitometer.
- 8.6 Exposure and processing of production radiographs shall be such that:
 - 8.6.1 The H&D density through the weld metal for transparent-based film shall be:
 - 1. Not less than 1.8, and
 - 2. Not more than 4.0.
 - 8.6.2 The images of the image quality indicator's (IQI) identifying style number, ASTM set letter, and essential wire diameter shall all appear clearly on the radiograph.

9.0 Production Radiography

- 9.1 Only RT procedures approved by AIC shall be used. A single-wall exposure/single wall viewing (SWE/SWV) radiographic technique should be used when practical and safe to do so. When not practical to use a single-wall exposure technique, a double-wall exposure technique shall be used.
 - 9.1.1 However, when a double-wall exposure/single wall viewing (DWE/SWV) radiographic technique is used, there shall be a minimum of 3 exposures for each weld examined.
- 9.2 When more than 1 radiographic film is used to examine a weld, the following requirements shall be met:
 - 9.2.1 Complete weld identification shall appear on each film image.
 - 9.2.2 Adjacent film images shall overlap by a minimum of 2"; and
 - 9.2.3 At the ends of adjacent film, the same circumferential location marker shall appear on both films, as evidence of complete coverage.
- 9.3 Use only lead foil intensifying screens and having minimum thickness front and back at 0.005".
- 9.4 The weld identification (ID) numbering system will be established by AIC and furnished to the radiographic contractor prior to construction role.
 - 9.4.1 All film shall be clearly identified using lead letters/numbers or with a film ID flasher as follows:
 - 1. ID numbers/letters to be 1/4" - 3/8" height.
 - 2. Minimum ID to include contractor name, date, job number, weld number, Ameren-IL.

3. When using a film ID flasher, then flash information on the overlap end of each film.
- 9.4.2 Unless otherwise approved as location markers, a numbering belt shall be used during production radiographic examination. It shall be of enough length to cover the entire circumference of the weld.
1. Place numbering belt adjacent to the weld with lead numbers representing specific increments in "inches", as designated by AIC. Start the numbers with "0" and proceed in a clockwise direction. Practice maximum 4" increments on pipe 6" and larger.
 2. Place the number "0" in the number belt in line with the "top button" of the weld. Using the specified marking material, mark the pipe at this location along with an arrow showing the direction of location marker numbering.
 3. The direction of location marker numbering shall be the same throughout the project and will be conveyed to the radiographic contractor by AIC prior to production radiography.
- 9.4.3 The radiographic contractor shall visibly mark any weld that is to be repaired or cut-out.
1. The marking medium shall be such that the markings on the pipe will be identifiable until the location of the weld and final disposition have been recorded
- 9.4.4 The use of permanent markers (e.g., felt pen, "sharpies") are prohibited and shall not be used to make marks on the radiographic film.
- 9.4.5 Facilities and Equipment for Viewing Radiographs
1. The following facilities and equipment shall be used for radiographic film interpretation on AIC projects:
 - 1 a. Viewing facilities shall provide subdued background lighting of an intensity that will not cause reflections, shadows, or glare on the radiograph that interfere with the interpretation process.
 - 1 b. Viewing unit shall be high intensity type light equipped with a dimmer control as part of the equipment to provide proper illumination for the range of densities being viewed.
 - 1 c. The equipment shall produce enough illumination to view a maximum density of H&D 4.0.
 - 1 d. The viewing screen shall be provided with masks to reduce the lighted area to the film size and control light coming through low-density portions of the radiograph that could interfere with interpretations.
 - 1 e. The screen shall be free of scratches, dirt or other debris that could lead to misinterpretations.
- 9.4.6 Film Densitometer
1. A film densitometer (for checking film density) shall be provided on each radiographic testing unit (e.g., darkroom) and shall be used by the RT personnel to ensure the specification densities are met.
 2. Each film densitometer shall have an attached calibration sticker and be kept in good working condition.

3. Use a density calibration strip to calibrate the unit daily prior to production use. The calibration shall be documented, and record maintained.

9.4.7 Radiographic Equipment Requirements - General

1. The radiographic contractor shall provide radiographic inspection units equipped with all equipment and supplies necessary to produce, process, and interpret radiographs at the job site.
2. All equipment shall always be maintained in a good repair state .
3. Enough spare equipment should be readily available to eliminate downtime of radiographic operations.
4. Only equipment approved by AIC should be used for production radiography.

9.4.8 Darkroom Facilities - General

1. Darkrooms should be equipped for use as film processing and film viewing facilities.
2. The radiographic contractor may elect to use separate facilities for each function providing the requirements of this specification are met.
3. In addition to having processing capability for all film, the darkroom should meet the following minimum conditions:
 - 3 a. Darkrooms or viewing facilities should be large enough to comfortably accommodate at least 2 people viewing radiographs.
 - 3 b. Each darkroom or viewing facility shall have at least 1 film viewer that meets the Film Viewers requirements listed in [Paragraph 9.4.5](#).
 - 3 c. Each darkroom shall be equipped with a film densitometer for checking the film density.
 - 3 d. Each darkroom shall have electric power plants of sufficient size to independently operate all equipment.
 - 3 e. Recommend heating and air conditioning of darkroom.

9.4.9 Production Quality

1. The radiographic contractor shall perform all work under this specification in an orderly and expeditious manner while always maintaining required quality.
2. Reasonable time will be provided for the performance of the girth weld radiography and documentation, but at no time shall unnecessary delays be allowed due to equipment, supply, or personnel problems.

9.4.10 Standards of Acceptability

1. The standard of acceptability for radiographic film interpretation shall be API Std 1104, latest PHMSA approved edition.
2. The radiographic contractor's interpreter shall be responsible for assuring all radiographs are interpreted in accordance with API Std 1104.
3. Imperfections identified in the radiograph shall be measured, using a ruler and/or optical comparator.
 - 3 a. Ruler: A clear, thin plastic ruler graduated in at least 1/16" increments shall be used for measuring weld imperfections.

- 3 b. Optical Comparator: If it is necessary to use a comparator, it is recommended that the maximum of 7X power be used, and it should have a positive focusing adjustment.
4. In the case of broken or elongated slag lines that appear in the same plane or line, each indication shall be measured, and the total length of all indications used to determine the acceptance of this discontinuity

9.4.11 Film Review

1. AIC representative shall have the right to review radiographs at any time during the project.
2. The welding contractor shall have the right to review radiographs only when accompanied by AIC representative.
3. Radiographs may be reviewed on the pipe right-of-way provided it does not interfere with radiographic inspection operations.

9.4.12 Film Storage

1. Radiographic film of all acceptable welds and/or repairs shall be carefully prepared and filed in compartmentalized boxes or placed in envelopes in numerical order.
2. Radiographic film of unacceptable welds shall be stored with the repair radiographs.
3. Radiographic film of cut-out welds shall be stored separately.
4. The RT contractor will process, handle, and store the images in a manner that they are interpretable for at least 3 years after they are produced.
5. When boxes are used, each box shall contain a grid sheet identifying the radiographic film in each compartment and a copy of the applicable inspection reports.
6. The following information shall be placed on the front edge of the radiographic film boxes or envelopes:

Ameren Illinois
Film Container Number _____
Date _____
X-ray Numbers _____ to _____
Radiographic Contractor's Name _____
Line Section _____
P.O. No. _____

- 9.4.13 Film Retention: Upon completion of the review of the weld radiographs, and at discretion of the AIC Representative, the film may be properly discarded (even though RT contractor has requirement under [Paragraph 9.4.12, Item 4](#)). Otherwise, see [Paragraph 10.2.3](#).

9.4.14 If other imaging media is recorded on discs, the discs should become part of the final job packet.

10.0 Reports

10.1 Daily Radiographic Examination Reports

10.1.1 The radiographic contractor shall be responsible for furnishing the field AIC representative and construction contractor's representative with a detailed report of each previous day's radiography results.

10.1.2 The daily radiographic report supplied to AIC should include the following:

1. Weld ID number.
2. Status of weld (acceptable/unacceptable).
3. Defect type.
4. Location of defect on pipe circumference.
5. Location of defect in reference to cross-section (based on judgment).
6. Date radiography performed.
7. Pipe diameter & wall thickness.
8. Well Location.
9. Number of welds radiographed.
10. Type of exposure: Single Wall Exposure/Single Wall Viewing (SWE/SWV) or Double Wall Exposure/Single Wall Viewing (DWE/SWV), etc.
11. Crew size and Unit No.
12. Radiographer's signature.
13. Defect code per API Std 1104, Section 9. (20th Edition as current)
14. AIC representative's signature.

10.2 Report Retention

10.2.1 A copy of the daily radiographic reports showing the location and disposition of each weld shall be maintained in AIC's permanent job file for life of the pipeline.

10.2.2 In addition to retaining daily radiographic reports, establish and retain a project summary for life of the pipeline that includes the following:

1. Total welds made,
2. Total welds repaired,
3. Total welds cut-out, AND
4. Certification by the Project Engineer or Chief Welding Inspector that all work and radiographic inspection was performed in accordance with 49 CFR 192 requirements and API Std 1104.

10.2.3 With the certified project summary, the radiographic film can be disposed after waiting 1 year for any possible audit of the construction files (including film) or for some other specific issue. This recognizes that the film has served its purpose and can rapidly deteriorate and become unmeaningful and contentious. Film disposal shall be in an environmentally safe manner.

End of Instructions.

Operator Qualification (OQ) Required?

YES

0601: NDT - Radiographic Testing

0811: Visual Inspection of Welding and Welds

Appendices

NONE.

Attachments

NONE.

Compliance Requirements

49 CFR Part 192 - Transportation of Natural and Other Gas by Pipeline: Minimum Federal Safety Standards

American Petroleum Institute (API), Std 1104, "Standard for Welding Pipelines and Related Facilities", with Appendix B, "In-Service Welding"

Illinois Commerce Commission (ICC) Title 83: Public Utilities, Part 590, Minimum Safety Standards for Transportation of Gas and for Gas Pipeline Facilities, available online [here](#).

Reference Documents

[WELD 2.3 Welding: Construction of Pipelines](#)

American Society of Nondestructive Testing (ASNT), Recommended Practice No. SNT-TC-1A, "Personnel Qualification and Certification in Nondestructive Testing"

American Society for Testing Materials (ASTM), E94-17, "Standard Guide for Radiographic Examination Using Industrial Radiographic Film"

Document Rescission

WELD 2.6 Welding: Radiographic Testing, December 15, 2021

Revision Notes

Location of Changes	Summary of Changes
Subsection 5.2 – Test Personnel	The assistant radiographer or trainee shall have a State of Illinois' Industrial Radiographer Certification Card.

WELDING

October 1, 2022

WELD 2.7 Magnetic Particle Testing

1.0 Purpose

This document is to outline the requirements to be followed by Ameren Illinois (AIC) when Magnetic Particle Testing is performed for examination of pipelines and related facilities.

2.0 Scope

This document addresses the following:

[3.0 Target Audience](#)[4.0 General](#)[5.0 Magnetic Particle Testing Personnel](#)[6.0 Magnetic Particle Testing Procedures](#)[7.0 Method and Equipment](#)[8.0 Dry Magnetic Particle Application](#)[9.0 Wet Magnetic Particle Application](#)[10.0 Interpretation and Acceptance](#)[11.0 Reports](#)[12.0 Report Retention](#)**3.0 Target Audience**

- Gas Tech Engineering (GTE)
- Gas Integrity Management Personnel
- Gas Engineers
- Gas Superintendents
- Gas Supervisors
- Gas Field Personnel - Welders
- Gas Construction Services Superintendents
- Gas Construction Services Supervisors
- Gas Contract Welding Inspectors
- Contract Gas Construction Company Supervisors
- Contract Gas Construction Company Welders
- Contract NDT Personnel

4.0 General

- 4.1 This establishes magnetic particle examination/testing criteria that is to be used for examination of welds on new construction as well as being used during maintenance activities.
- 4.2 The magnetic particle examination method is applied to detect cracks and other imperfections on the surface of ferromagnetic materials.
- 4.3 In principle, this method involves magnetizing an area to be examined, and applying ferromagnetic particles to the surface. Particle patterns form on the surface where the magnetic field is forced out of the part and over imperfections to cause a leakage field that attracts the particles. Particle patterns are usually characteristic of the type imperfection that is detected.

UNCONTROLLED IF PRINTED

- 4.4 Whichever technique (Dry or Wet) is used to produce the magnetic flux in the part being examined, maximum sensitivity will be to linear imperfections oriented perpendicular to the lines of flux. For optimum effectiveness in detecting all types of imperfections, each area is to be *examined at least twice*, with the flux lines during one examination being approximately perpendicular to the flux lines during the other examination.
 - 4.4.1 *Dry Magnetic Particle* testing shall be used when the temperature of the surface being tested is between 100 °F and 600 °F. However, dry magnetic particle testing can be done on surfaces under 100 °F.
 - 4.4.2 *Wet Magnetic Particle* testing is acceptable with contrast only and only when the temperature of the surface being tested is below 100 °F.
- 4.5 AIC does not allow magnetic particle examination on surface areas that are coated or painted. Contrast coating used for wet magnetic testing is not considered a paint or coating.

5.0 Magnetic Particle Testing Personnel

- 5.1 All Level I, Level II, and Level III magnetic particle testing (MT) personnel for AIC assignment to perform examinations and evaluate results shall provide AIC Gas Compliance with the following written documentation prior to work activity:
 - 5.1.1 Certification or recertification by their employer in the Magnetic Particle Testing method for the following:
 1. Previous 3 years as either a Level I or Level II, and
 2. Previous 5 years for Level III.

NOTE:	A 5 years recertification interval for Level I, and Level II may be acceptable, if approved by AIC, for those NDT companies which conduct the additional required certification testing.
--------------	--

- 5.1.2 Documentation shall include the following minimum information:
 1. Name of certified individual.
 2. Level of certification (e.g., Level II, Level III).
 3. Educational background and experience of certified individual.
 4. Statement indicating satisfactory completion of training in accordance with employer's written practice.
 5. Results of certification examination (grades).
 6. Date of certification and/or recertification.
 7. Certification expiration date.
 8. Signature of employer's certifying person.
- 5.1.3 Certifications shall be in accordance with American Society for Nondestructive Testing, Recommended Practice No. SNT-TC-1A.
- 5.2 Vision Acuity Record
 - 5.2.1 Current record of individual's near-vision acuity results administered by an approved medical professional to ensure natural or corrected near-distance acuity in at least one eye. This is to verify that individual can read a minimum of Jaeger Number 1 or equivalent type and size letter at a distance not less than 12".

- 5.2.2 Documentation of successful results from an administered color-contrast differentiation examination within the past 5 years.
- 5.3 AIC Project Engineer or Construction Inspector shall request the above information when the magnetic particle testing contractor is contacted and prior to a work assignment.
- 5.4 All MT testing personnel engaged in the examination and evaluation of magnetic particle results performed for AIC shall maintain a copy of their certifications credentials on the job site.
- 5.5 Only Level II or Level III MT testing personnel shall:
 - 5.5.1 Interpret magnetic particle testing results.
 - 5.5.2 Report all defects observed.
 - 5.5.3 Indicate whether the weld meets standard of acceptability as specified in the referencing code standard (i.e., API Std. 1104, Section 9.4).
- 5.6 MT personnel may be required to:
 - 5.6.1 Demonstrate their ability to produce acceptable magnetic particle examination results using approved procedures prior to performing production magnetic particle testing.
 - 5.6.2 Be recertified at the option of AIC or if any question arises about their ability. Level II or III MT personnel's work will be subject to review by AIC representative and any pattern of inconsistency will be cause for additional training, testing, or dismissal.
- 5.7 AIC shall have the right to remove any MT personnel who, in the opinion of the AIC representative, is incompetent, careless, unsafe, or otherwise not qualified to perform the work assigned, or who is found to be insubordinate or guilty of improper conduct.

6.0 Magnetic Particle Testing Procedures

- 6.1 General
 - 6.1.1 This section prescribes the minimum requirements for establishing and qualifying the magnetic particle testing procedures to be used for examination of welds.
 - 6.1.2 The NDE contractor shall provide a detailed procedure to produce acceptable magnetic particle examination results.
- 6.2 Procedure Qualification
 - 6.2.1 All procedures to be used on the work assignment shall be qualified prior to performing any magnetic particle examination of a production nature.
 - 1. Advanced notice must be given to AIC to schedule personnel for witnessing the procedure qualification.
 - 2. AIC representative shall determine the acceptance of procedure.
 - 3. Procedure shall be qualified by performing an acceptable magnetic particle examination of a weld following approval of the procedure.
 - 4. A completed Qualification Form shall be provided by the NDE contractor for acceptance by AIC.
 - 6.2.2 AIC representative may further review all procedure details and the test results prior to beginning testing.

UNCONTROLLED IF PRINTED

- 6.2.3 The MT testing Level II or III technician performing the magnetic particle test will be simultaneously qualified in the procedure.
- 6.2.4 Qualified procedures may be used by other MT Level II or III technicians from the same contractor provided they have a copy of the procedure record and they qualify their ability to produce an acceptable magnetic particle examination using the procedure details.
- 6.2.5 The approved qualified procedure(s) used for inspecting welds should be filed in the job packet.

7.0 Method and Equipment

7.1 General

- 7.1.1 Reference Table 2, Recommended NDT Methods under [WELD 2.3, Paragraph 11.1.2](#).
- 7.1.2 Welds shall meet visual acceptance criteria prior to MPT.
- 7.1.3 All magnetic particle examinations shall be performed utilizing the continuous magnetization method (i.e., current flow is energized while ferromagnetic particles are being applied) with either wet or dry ferromagnetic particles.

Under no circumstances shall the "Prod Technique" be used for examination of pipeline girth welds due to potential of arcing the pipe during examination.

- 7.1.4 Permanent magnets are banned from use.
- 7.1.5 All examinations shall be conducted with enough field overlap to ensure 100% coverage.

7.2 Yoke Technique

- 7.2.1 Either an alternating current (AC) or direct current (DC) electromagnetic yoke may be used.
- 7.2.2 Each weight shall be weighed with a properly calibrated scale and stenciled with the applicable nominal weight prior to first use.
- 7.2.3 Verify the magnetizing power of yokes prior to use each day the yoke is used. Record the power on the NDE Contractor's daily inspection report.
 - 1. The lifting power of each yoke shall be confirmed by its ability to lift the specified test weight in a vertical direction at the maximum pole spacing that will be used.
 - 1 a. AC electromagnetic yoke at 10 lbs.
 - 1 b. DC electromagnetic yoke at 40 lbs.
- 7.2.4 Electromagnetic yoke shall be used to examine groove and fillet welds, and should be conducted in the following manner:
 - 1. Poles of the magnetic yoke shall be adjusted to ensure:
 - 1 a. Good contact with the surface to be examined, and
 - 1 b. Distance between poles does not exceed 6".

UNCONTROLLED IF PRINTED

2. When area to be examined is 4" or less, the yoke shall be placed on the part being examined as shown in [Figure 1](#).
3. Apply the magnetic powder by lightly dusting the area between the poles.
4. Use the squeeze air bulb to lightly remove excess powder. Attention must be given to not remove any magnetic particle indications that have formed.
5. Remove the yoke and evaluate the magnetic particle indications.
6. Clean the surface with a paper towel or dry rag and repeat the examination with the yoke pole positions as shown in [Figure 2](#). Repeat the action steps 3 thru 5 above.
7. When the area to be examined is greater than 4", repeat steps 3 thru 5 for Figures 1 and 2 with pole positions overlapping as shown in [Figure 3](#) for each 4" of area examined.

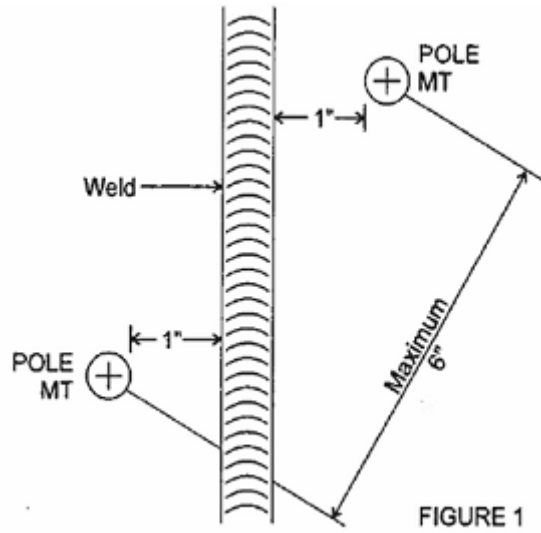

Figure 1: Magnetic Particle Inspection Sequence

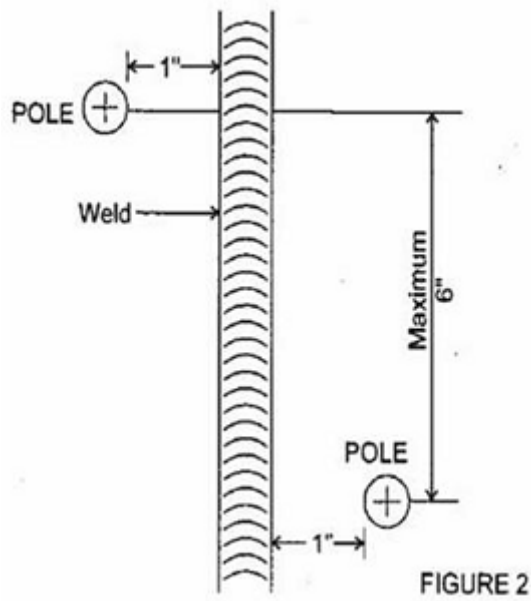

Figure 2: Magnetic Particle Inspection Sequence

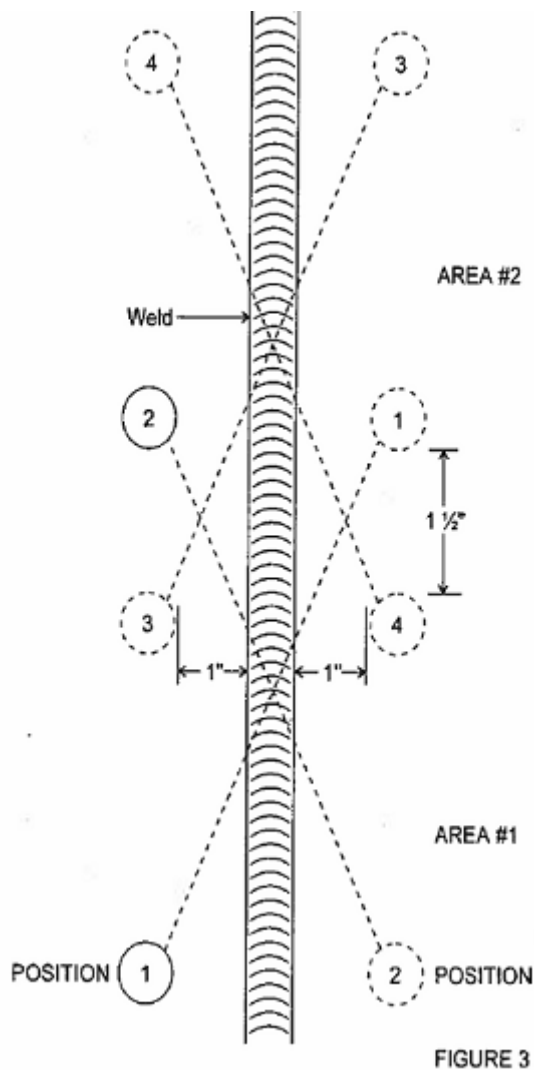

Figure 3: Magnetic Particle Inspection Sequence

7.3 Examination Medium

7.3.1 General: Magnetic particle properties and concentrations shall meet the minimum requirements as identified in ASTM E709.

7.3.2 Visible Dry Color Magnetic Particles

1. The visible dry method may utilize magnetic particles which contrast with the examination surface.
2. Color of the magnetic particles shall be different than color of the examination surface.

7.3.3 Visible Wet Color Contrast Magnetic Particles:

1. The visible wet method may utilize black oxide (ink) magnetic particles that are applied over a white background paint to provide contrast with the examination surface.

8.0 Dry Magnetic Particle Application

- 8.1 Preparation: Prior to performing magnetic particle examinations, all areas to be examined shall be free of slag, spatter, scale, dirt, paint, grease, and any other foreign matter that could mask or interfere with interpretation of imperfections.
- 8.2 Dry Continuous Magnetization Technique
 - 8.2.1 Dry particles lose most of their mobility when they contact the surface of a part. Therefore, it is imperative that the area under examination be under the influence of the applied magnetic field while the particles are still airborne and free to be attracted to leakage fields.
 - 8.2.2 Before applying dry magnetic particles, start the flow of magnetizing current. Stop the current flow after completing powder application and blowing off excess powder.
- 8.3 Dry Magnetic Powder Application
 - 8.3.1 Do NOT apply dry magnetic particles to damp surfaces
 - 8.3.2 Use a bulb-type applicator to apply dry magnetic powder such that a light uniform, dust-like coating settles upon the surface of the part while it is being magnetized.
- 8.4 Dry Magnetic Powder Removal
 - 8.4.1 Removal of excess dry magnetic powder is generally done while the magnetizing current is present.
 - 8.4.2 Use a squeeze air bulb which permits removal of excess dry magnetic particles without affecting the relevant magnetic particle indications.

Exercise care to prevent removing particles attracted by leakage field, which may prove to be a relevant indication.

9.0 Wet Magnetic Particle Application

- 9.1 Preparation: Prior to performing magnetic particle examinations all areas to be examined shall be free of slag, spatter, scale, dirt, paint, grease, and any other foreign matter that could mask or interfere with the interpretation of imperfections.
- 9.2 Technique: The wet continuous magnetization technique involves bathing the part with the examination medium to provide an abundant source of suspended particles on the surface of the part. Then, terminating the bath application immediately prior to the termination of the magnetizing current.
- 9.3 Wet Magnetic Particle Application
 - 9.3.1 Wet magnetic particles suspended in a container/vehicle at a recommended concentration may be applied either by spraying or flowing over the areas to be examined during the application of the magnetizing field current (continuous technique).
 - 9.3.2 The wet medium may be applied using either aerosol spray can or spray pump to evenly apply the wet particles over the examination surface.
- 9.4 Visible Wet Color Contrast Magnetic Particles:
 - 9.4.1 The visible wet method uses contrasting color magnetic particles over the background coating on the test area.

UNCONTROLLED IF PRINTED

10.0 Interpretation and Acceptance

- 10.1 Interpretation shall be carried out to identify the location and character of the indication.
- 10.2 The interpretation shall identify if an indication is false, nonrelevant, or relevant. False and nonrelevant indications shall be proven as false or nonrelevant.
- 10.3 All relevant indications shall be evaluated in accordance with API Std 1104 (latest PHMSA approved edition), Acceptance Standards for Nondestructive Testing, Section 9.4, Magnetic Particle Testing.

11.0 Reports

11.1 Daily Magnetic Particle Examination Reports

- 11.1.1 The NDE contractor shall be responsible for furnishing the field AIC representative and construction contractor's representative with a detailed report of each previous day's magnetic particle testing results.
- 11.1.2 The daily magnetic particle testing report supplied to AIC for the inspection of welds shall include the following:
 - 1. Weld ID number.
 - 2. Status of weld (acceptable/unacceptable).
 - 3. Defect type.
 - 4. Location of defect on pipe circumference.
 - 5. Location of defect in reference to cross-section (based on judgment).
 - 6. Date inspection was performed.
 - 7. Pipe diameter & wall thickness.
 - 8. Weld location.
 - 9. Number of welds tested.
 - 10. Technique used.
 - 11. Testing equipment identification and calibration date.
 - 12. Magnetic particle type.
 - 13. MT technician's signature.
 - 14. AIC Representative's signature.
- 11.1.3 The NDE contractor shall keep a copy of all daily reports for the duration of their project assignment.

12.0 Report Retention

- 12.1 A copy of the daily MT report showing the location and disposition of each weld inspected shall be maintained in AIC's permanent job file for life of the pipeline.

End of Instructions.

Operator Qualification (OQ) Required?

YES

0621: NDT - Magnetic Particle Testing

UNCONTROLLED IF PRINTED

811: Visual Inspection of Welding and Welds .

Appendices

NONE.

Attachments

NONE.

Compliance Requirements

49 CFR Part 192 - Transportation of Natural and Other Gas by Pipeline: Minimum Federal Safety Standards

American Petroleum Institute (API), Std 1104, "Standard for Welding Pipelines and Related Facilities", with Appendix B, "In-Service Welding"

Illinois Commerce Commission (ICC) Title 83: Public Utilities, Part 590, Minimum Safety Standards for Transportation of Gas and for Gas Pipeline Facilities, available online [here](#).

Reference Documents

[WELD 2.3 Welding: Construction of Pipelines](#)

American Society of Nondestructive Testing (ASNT), Recommended Practice No. SNT-TC-1A, "Personnel Qualification and Certification in Nondestructive Testing"

American Society for Testing Materials (ASTM), E709, Standard Guide for Magnetic Particle Testing

Document Rescission

WELD 2.7 Welding: Magnetic Particle Testing, December 15, 2021

Revision Notes

Location of Changes	Summary of Changes
Paragraph 5.2 - Magnetic Particle Testing Personnel	Removed this section on assistant and trainee since this is a one-person operation there are no helpers.

WELDING

October 1, 2022

WELD 2.8 Liquid Penetrant Testing

1.0 Purpose

This document outlines the requirements and specifications to be followed by Ameren Illinois (AIC) when Liquid Penetrant Examination is used for examination of welds on new pipeline construction and during maintenance activities on pipelines and related facilities.

2.0 Scope

This document addresses the following:

[3.0 Target Audience](#)[4.0 General](#)[5.0 Liquid Penetrant Testing Personnel](#)[6.0 Liquid Penetrant Testing Procedures](#)[7.0 Method and Equipment](#)[8.0 Procedure](#)[9.0 Interpretation and Acceptance](#)[10.0 Reports](#)[11.0 Report Retention](#)**3.0 Target Audience**

- Gas Tech Engineering (GTE)
- Gas Integrity Management Personnel
- Gas Engineers
- Gas Superintendents
- Gas Supervisors
- Gas Field Personnel - Welders
- Gas Construction Services Superintendents
- Gas Construction Services Supervisors
- Gas Contract Welding Inspectors
- Contract Gas Construction Company Supervisors
- Contract Gas Construction Company Welders
- Contract NDT Personnel

4.0 General

- 4.1 The liquid penetrant examination method is applied to detect cracks and other imperfections that are open to the surface of materials under examination.
- 4.2 The liquid penetrant is applied evenly over the surface being examined and allowed to enter open imperfections. After a suitable dwell time, the excess surface penetrant is removed. A developer is applied to draw entrapped penetrant out of the imperfection and stain the developer. The test surface is then examined to determine the presence or absence of indications.
- 4.3 This specification is limited to using only visible, solvent removable liquid penetrant materials.
- 4.4 AIC does not allow liquid penetrant examination on surface areas that are coated or painted.

UNCONTROLLED IF PRINTED

5.0 Liquid Penetrant Testing Personnel

5.1 All Level I, Level II, and Level III liquid penetrant testing (PT) personnel for AIC assignment to perform examinations and evaluate results shall provide AIC Gas Compliance with the following written documentation prior to work activity:

5.1.1 Certification or recertification by their employer in the Liquid Penetrant Testing method for the following:

1. Previous 3 years as either a Level I or Level II, and
2. Previous 5 years for Level III.

NOTE:	A 5 years recertification interval for Level I, and Level II may be acceptable, if approved by AIC, for those NDT co
--------------	--

5.1.2 Documentation shall include the following minimum information:

1. Name of certified individual.
2. Level of certification (e.g., Level II, Level III).
3. Educational background and experience of certified individual.
4. Statement indicating satisfactory completion of training in accordance with employer's written practice.
5. Results of certification examination (grades).
6. Date of certification and/or recertification.
7. Certification expiration date.
8. Signature of employer's certifying person.

5.1.3 Certifications shall be in accordance with American Society for Nondestructive Testing, Recommended Practice No. SNT-TC-1A.

5.2 Vision Acuity Record

5.2.1 Current record of individual's near-vision acuity results administered by an approved medical professional to ensure natural or corrected near-distance acuity in at least one eye such that individual can read a minimum of Jaeger Number 1 or equivalent type and size letter at a distance not less than 12".

5.2.2 Documentation of successful results from an administered color-contrast differentiation examination within past 5 years.

5.3 AIC Project Engineer or Construction Inspector shall request the above information when the liquid penetrant testing contractor is contacted for and prior to a work assignment.

5.4 All PT personnel engaged in the examination and evaluation of liquid penetrant testing results performed for AIC shall maintain a copy of their certifications credentials on the job site.

5.5 Only Level II or Level III PT testing personnel shall:

5.5.1 Interpret liquid penetrant testing results.

5.5.2 Report all defects observed.

5.5.3 Indicate whether the weld meets standard of acceptability as specified in the referencing code standard (i.e., API Std. 1104, Section 9.5).

UNCONTROLLED IF PRINTED

5.6 PT personnel may be required to:

- 5.6.1 Demonstrate their ability to produce acceptable liquid penetrant examination results using approved procedures prior to performing production liquid penetrant testing.
- 5.6.2 Be recertified at the option of AIC or if any question arises about their ability. Level II or III PT personnel's work will be subject to review by AIC representative and any pattern of inconsistency will be cause for additional training, testing, or dismissal.

5.7 AIC shall have the right to remove any PT personnel who, in the opinion of the AIC representative, is incompetent, careless, unsafe, or otherwise not qualified to perform the work assigned, or who is found to be insubordinate or guilty of improper conduct.

6.0 Liquid Penetrant Testing Procedures

6.1 General

- 6.1.1 This section prescribes the minimum requirements for establishing and qualifying the liquid penetrant testing procedures to be used for examination of welds.
- 6.1.2 The NDE contractor shall provide a detailed procedure to produce acceptable liquid penetrant examination results.

6.2 Procedure Qualification

- 6.2.1 All procedures to be used on the work assignment shall be qualified prior to performing any liquid penetrant examination of a production nature.
 - 1. Advanced notice must be given to AIC to schedule personnel for witnessing the procedure qualification.
 - 2. AIC representative shall determine the acceptance of procedure.
 - 3. Procedure shall be qualified by performing an acceptable liquid penetrant examination of a weld following approval of the procedure.
 - 4. A completed Qualification Form shall be provided by the NDE Contractor for acceptance by AIC.
- 6.2.2 AIC representative may further review all procedure details and the test results prior to beginning testing.
- 6.2.3 The PT testing Level II or III technician performing the liquid penetrant test will be simultaneously qualified in the procedure.
- 6.2.4 Qualified procedures may be used by other PT Level II or III technicians from the same contractor provided they have a copy of the procedure record and they qualify their ability to produce an acceptable liquid penetrant examination using the procedure details.

7.0 Method and Equipment

7.1 General

- 7.1.1 Reference Table 2, Recommended NDT Methods under [WELD 2.3, Paragraph 11.1.2](#).
- 7.1.2 Welds shall meet visual acceptance criteria prior to LPT.
- 7.1.3 All liquid penetrant examinations shall be performed only by utilizing the visible, solvent removable liquid penetrant materials with nonaqueous wet developers.

7.1.4 All examinations shall be conducted with enough field overlap to ensure 100% coverage.

7.2 Visible Penetrant

7.2.1 Visible penetrant testing uses a penetrant that can be seen in visible light.

7.2.2 The penetrant is usually red, so that resultant indications produce a definite contrast with the white developer background.

7.2.3 Visible penetrant indications shall be viewed under adequate white light.

7.3 Other Materials

7.3.1 Solvent Removable Penetrants

1. Solvent removable penetrants are formulated so that excess surface penetrant can be removed by wiping until most of the penetrant has been removed.
2. The remaining traces of surface penetrant shall be removed with solvent remover.

To prevent removal of penetrant from imperfections, care shall be taken to avoid using excess solvent.

3. Do NOT flush the surface with solvent to remove excess penetrant as the penetrant indications could easily be washed away.

7.3.2 *Solvent Removers*: Such removers function by dissolving the penetrant, making it possible to wipe the surface clean and free of excess penetrant.

7.3.3 *Developers*: Developers form a translucent or white absorptive coating that aids in bringing the penetrant out of surface imperfections through a blotting action, thus increasing visibility of the indications.

1. Nonaqueous Wet Developers

- 1 a. Nonaqueous wet developers are suspensions of developer particles in a nonaqueous solvent carrier ready for use as supplied.
- 1 b. Nonaqueous wet developers are sprayed on to form a thin coating on the part's surface when dried. This thin coating serves as the developing medium.

8.0 Procedure

8.1 The following processing parameters apply to the visible penetrant testing method.

8.1.1 *Temperature Limits*: The temperature of penetrant materials and the material surface under examination shall be between 40 °F and 125 °F.

Specific qualified PT procedures for testing welds outside of the above temperatures shall be approved by AIC.

- 8.1.2 *Examination Sequence*: Final penetrant examination shall be performed after completing all operations that could cause surface connected imperfections or operations that could expose imperfections not previously open to the surface.

8.2 Pre-cleaning

Specific qualified PT procedures for testing welds outside of the above temperatures shall be approved by AIC.

- 8.2.1 The success of any penetrant examination procedure is greatly dependent upon the surrounding surface and imperfection being free of any contaminants that might interfere with the penetrant entering imperfections.
- 8.2.2 Ensure all surfaces to be examined are clean and dry before applying penetrant.
1. "*Clean*" means that the surface must be free of rust, scale, welding flux, weld spatter, grease, paint, oily films, dirt, and any foreign material that might interfere with the penetrant process.
 2. If only a section of a part is involved, such as a weld, include the heat affected zone for examination. Thus, remove all contaminants from the total area subject to examination.
- 8.2.3 If necessary, grinding is permitted to eliminate surface irregularities that could mask indications of unacceptable imperfections.
- 8.2.4 It is essential that the examination surface be thoroughly dry after cleaning. Any liquid residue will hinder the entrance of the penetrant.

8.3 Penetrant Application:

- 8.3.1 After the part has been cleaned, dried, and is within the specified temperature range, penetrant may be applied to the surface to be examined. Ensure the entire part or area under examination is completely covered with penetrant.
- 8.3.2 Application methods may include dipping, brushing, flooding, or spraying.

8.4 Penetrant Dwell Time

- 8.4.1 After application, allow excess penetrant to drain from the part while allowing for proper penetrant dwell time. Ensure that no pooling of penetrant forms on the part.
- 8.4.2 The dwell time for penetrant to remain on part (for proper penetration) shall be as recommended by penetrant manufacturer and not be exceeded.

8.5 Penetrant Removal

- 8.5.1 After the required penetrant dwell time, remove excess penetrant by wiping with a dry, clean, lint-free cloth/towel.
- 8.5.2 Follow-up by using a clean, lint-free cloth/towel lightly moistened with solvent remover to remove the remaining traces of surface penetrant.

Use gentle wiping to avoid removing penetrant from any imperfections.

8.5.3 Fully dry the surface for examination prior to applying nonaqueous wet developers. Drying time is only that necessary to adequately dry the part.

8.6 Developer Application

8.6.1 After excess penetrant has been removed and surface dried, apply nonaqueous wet developer in a manner to ensure complete part coverage with a thin, even film. However, apply thick enough to provide a contrasting background.

8.6.2 Do NOT dip or flood parts with nonaqueous wet developer, because the solvent action of these type developers can flush or dissolve the penetrant from within the imperfections.

8.7 Developing Time

8.7.1 Developing time begins immediately after the coating of wet developer is dry.

8.7.2 Developer is to remain on the part prior to examination not less than 10 minutes.

8.7.3 Maximum developing times shall be 1 hour.

8.8 Inspection

8.8.1 After the applicable developing time, perform examination of part under visible light as appropriate.

8.8.2 It is advisable to observe the "bleed out" during developing time as an aid in interpreting indications.

9.0 Interpretation and Acceptance

9.1 Interpretation shall be carried out to identify the location and character of the indication.

9.2 The interpretation shall identify if an indication is false, nonrelevant, or relevant. Further, the false and nonrelevant indications shall be proven as to which (i.e., false or nonrelevant).

9.3 All relevant indications shall be evaluated in accordance with API Std 1104 (latest PHM-SA approved edition), Acceptance Standards for Nondestructive Testing, Section 9.5, Liquid Penetrant Testing.

10.0 Reports

10.1 Daily Liquid Penetrant Examination Reports

10.1.1 The NDE contractor shall be responsible for furnishing the field AIC representative and construction contractor's representative with a detailed report of each previous day's liquid penetrant testing results.

10.1.2 The daily liquid penetrant testing report supplied to AIC for inspection of welds shall include the following:

1. Weld ID number.
2. Status of weld (acceptable/unacceptable).
3. Defect type.
4. Location of defect on pipe circumference.
5. Location of defect in reference to cross-section (based on judgment).
6. Date inspection was performed.
7. Pipe diameter & wall thickness.

8. Weld location.
 9. Number of welds tested.
 10. Technique used.
 11. Testing equipment identification and calibration date.
 12. Liquid penetrant used and batch number.
 13. Lighting utilized and intensity.
 14. Dwell times applied.
 15. PT technician's signature.
 16. AIC Representative's Signature.
- 10.1.3 When appropriate for documentation purposes, photographs of defect indication may be attached to report by any suitable means.
- 10.1.4 The NDE contractor shall keep a copy of all daily reports for the duration of their project assignment.

11.0 Report Retention

- 11.1 A copy of the daily PT report showing the disposition and location of each weld inspected shall be maintained in AICs' permanent job file for life of the pipeline.

End of Instructions.

Operator Qualification (OQ) Required?

YES

0611: NDT - Liquid Penetrant Testing

811: Visual Inspection of Welding and Welds

Appendices

NONE.

Attachments

NONE.

Compliance Requirements

49 CFR Part 192 - Transportation of Natural and Other Gas by Pipeline: Minimum Federal Safety Standards

American Petroleum Institute (API), Std 1104, "Standard for Welding Pipelines and Related Facilities", with Appendix B, "In-Service Welding"

Illinois Commerce Commission (ICC) Title 83: Public Utilities, Part 590, Minimum Safety Standards for Transportation of Gas and for Gas Pipeline Facilities, available online [here](#).

Reference Documents

[WELD 2.3 Welding: Construction of Pipelines](#)

UNCONTROLLED IF PRINTED

American Society of Nondestructive Testing (ASNT), Recommended Practice No. SNT-TC-1A, "Personnel Qualification and Certification in Nondestructive Testing"

American Society for Testing Materials (ASTM), E165, Standard Practice for Liquid Penetrant Testing for General Industry

Document Rescission

WELD 2.8 Welding: Liquid Penetrant Testing, December 15, 2021

Revision Notes

Location of Changes	Summary of Changes
Paragraph 5.2 – Liquid Penetrant Testing Personnel	Removed this section on assistant and trainee since this is a one-person operation there are no helpers.

WELDING

December 15, 2021

WELD 2.9 Ultrasonic Thickness Examination

1.0 Purpose

This document defines the minimum requirements for determining pipe or plate thickness for Ameren Illinois (AIC) using an ultrasonic thickness gauge. This is a means for checking pipe thickness in accordance with 49 CFR Part 192 requirements.

2.0 Scope

This document addresses the following:

[3.0 Target Audience](#)

[4.0 Equipment and Materials](#)

[5.0 Personnel Requirements](#)

[6.0 Instrument Calibration](#)

[7.0 Technique](#)

[8.0 Final Cleaning](#)

[9.0 Records](#)

3.0 Target Audience

- Gas Tech Engineering (GTE)
- Gas Integrity Management Personnel
- Gas Engineers
- Gas Superintendents
- Gas Supervisors
- Gas Field Personnel - Welders
- Gas Construction Services Superintendents
- Gas Construction Services Supervisors
- Gas Contract Welding Inspectors
- Contract Gas Construction Company Supervisors
- Contract Gas Construction Company Welders
- Contract NDT Personnel

4.0 Equipment and Materials

- 4.1 Use an approved digital thickness gauge when needing to perform various material thickness measurements.
 - 4.1.1 Reference requirement for using ultrasonic thickness measurements as part of Internal Corrosion Direct Assessment (ICDA) per 49 CFR Section 192.927(c)(3).
- 4.2 AIC uses a DeFelsko PosiTector UTG. See [WELD 4](#) for the DeFelsko Full Guide manual.
- 4.3 Couplant is a liquid that facilitates transmission of ultrasonic energy to the specimen being tested. It can be a variety of liquids, such as oil, lubricants, water, glycerin.

5.0 Personnel Requirements

- 5.1 Personnel operating the thickness gauge shall be thoroughly familiar with the manufacturer's instructions for the operation, application, calibration, and maintenance of the test instrument.

UNCONTROLLED IF PRINTED

- 5.2 Technician shall be familiar with API Std 1104 (latest PHMSA approved edition), Acceptance Standards for Nondestructive Testing, Section 9.6, Ultrasonic Testing.

6.0 Technique

- 6.1 Calibration of the digital thickness instrument shall be performed according to the manufacturer's instructions.
- 6.2 Instrument calibration shall be confirmed on the same material and product form (e.g., round pipe, flat plate) as the material to be measured.
- 6.3 For calibration confirmation, each instrument shall be supplied with a calibration step block machined with steps (size applicable) to the instrument used. The instrument calibration shall be re-checked approximately midway through the inspection process.
- 6.4 If the instrument is not in calibration, the previous thickness check shall be retaken.
- 6.5 The operator shall be alert to the need of using consistent transducer pressure, couplant type, and amount of couplant.

7.0 Technique

- 7.1 Remove excess dirt, loose scale, paint, epoxy, or other foreign material (from the surface to be examined) that could prevent accurate thickness measurements
- 7.2 Prepare the area to be examined such that a good contact between the transducer and the surface is obtained.
- 7.3 Apply the appropriate type couplant in a consistent manner (i.e., thin, uniform film) on the material to be examined. Use enough to get a clear imagine. See [Subsection 4.3](#) regarding couplants.
- 7.4 The transducer contact face must be held parallel to the pipe inside diameter surface.
- 7.5 Scan the complete area and record the minimum and maximum thickness readings.

8.0 Final Cleaning

- 8.1 After the readings have been recorded and instrument calibration re-checked, evaluate the resulting data for satisfaction/acceptance.
- 8.2 Remove the couplant completely from the examination surface to extent necessary for restoring coating where applicable.

9.0 Records

- 9.1 When AIC requires documenting the examination results the following information shall be recorded on the AIC Ultrasonic Thickness Record form. See [WELD 4](#).
- 9.1.1 Instrument model and serial number.
- 9.1.2 Transducer frequency.
- 9.1.3 Calibration standard.
- 9.1.4 Type couplant.
- 9.1.5 Date of examination.
- 9.1.6 Name of technician performing examination.
- 9.1.7 Examination result (minimum and maximum thickness obtained).

End of Instructions.

UNCONTROLLED IF PRINTED

Operator Qualification (OQ) Required?

YES

0631: NDT - Ultrasonic Testing

Appendices

NONE.

Attachments

NONE.

Compliance Requirements

49 CFR Part 192 - Transportation of Natural and Other Gas by Pipeline: Minimum Federal Safety Standards

American Petroleum Institute (API), Std 1104, "Standard for Welding Pipelines and Related Facilities", with Appendix B, "In-Service Welding"

Illinois Commerce Commission (ICC) Title 83: Public Utilities, Part 590, Minimum Safety Standards for Transportation of Gas and for Gas Pipeline Facilities, available online [here](#).

Reference Documents

[WELD 4 Welding: Forms and Reference Materials](#)

Document Rescission

WELD 2.9 Welding – Ultrasonic Wall Thickness Examination, October 1, 2020

Revision Notes

Location of Changes	Summary of Changes
Subsection 9.1 - Records	Removed <u>Appendices and Appendix A</u>

WELDING

October 1, 2021

WELD 2.10 Arc Burn Removal

1.0 Purpose

This document addresses the problem of arc burns as encountered during the welding process and the removal considerations/requirements by Ameren Illinois (AIC). It is in accordance with 49 CFR §192.309(c) requirements.

2.0 Scope

This document addresses the following:

[3.0 Target Audience](#)

[4.0 General](#)

[5.0 Removal Sequence](#)

[6.0 API Wall Thickness Tolerances](#)

Appendices

[Appendix A - API Table 9, 43rd Edition](#)

[Appendix B - API Table 11, 45th Edition](#)

3.0 Target Audience

- Gas Tech Engineering (GTE)
- Gas Integrity Management Personnel
- Gas Engineers
- Gas Supervisors
- Gas Field Personnel - Welders
- Gas Construction Services Supervisors
- Gas Contract Welding Inspectors
- Contract Gas Construction Company Supervisors
- Contract Gas Construction Company Welders
- Contract NDT Personnel

4.0 General

- 4.1 Technically, an arc burn or arc strike is the result of momentarily touching the electrode holder, electrode, or ground clamp to the pipe surface.
 - 4.1.1 These arc burns are usually of short duration and the depth of heating is superficial; however, the area will contain a much harder metallurgical structure called "martensite" from which small cracks may initiate.
 - 4.1.2 In addition to the hard structure and rapid cooling, the thin fused area of the arc burn is not properly protected from the environment since gas generated ingredients and slag formers in the electrode covering have not been heated and brought into use.
- 4.2 The PHMSA regulation 49 CFR §192.309(c) requires that any arc burn on pipe operating at or over 40% SMYS must be repaired or removed.
- 4.3 For the listed reasons, arc burns:
 - 4.3.1 Shall be removed on a transmission pipeline,
 - 4.3.2 Should be removed on a high-pressure distribution pipeline, or

UNCONTROLLED IF PRINTED

- 4.3.3 At the welding inspector's review option, cut out of the pipeline.

Consult with Gas Tech Engineering before grinding to repair any defect on transmission piping or high-pressure distribution piping operating above 100 psig. See [REPR 1](#).

- 4.4 A welder who repeatedly makes arc burns may be subject to disqualification or other disciplinary action, all at the discretion of AIC.
- 4.5 For related discussion, see the following:
- 4.5.1 [WELD 2.2, Section 8.0](#), Workmanship.
- 4.5.2 [WELD 2.3, Subsection 9.10](#), Weld Ground Placement, and
- 4.5.3 [WELD 2.3, Subsection 9.20](#), Arc Burns.

5.0 Removal Sequence

Arc Burns shall be removed as follows:

- 5.1 Determine the minimum wall thickness required for the pipe containing an arc burn. Refer to the following references for wall thickness tolerances based on manufactured date of the pipe:
- 5.1.1 Before 2009: See [Appendix A](#) for API 5L, 43rd Edition, Table 9, OR
- 5.1.2 During 2009 or later: See [Appendix B](#) for API 5L, 45th Edition, Table 11.
- 5.2 Measure the existing wall thickness surrounding the arc burn.
- 5.3 Compare the existing wall thickness with the minimum required wall thickness.
- 5.4 Providing there is adequate thickness remaining, grinding of the arc burn area may be performed.
- 5.5 Remove all evidence of the arc burn by grinding and/or filing.
- 5.6 Upon removal of all burn evidence, swab the "ground-out" area using a "Q-tip or cotton ball with an appropriate American Welding Society (AWS) approved etching solution.
- 5.6.1 This can be a 10 to 20% solution of ammonium persulfate (i.e., mix 20% ammonium persulfate crystals and 80% water).
- 5.6.2 If a blackened spot appears, the metallurgical notch (arc burn) has not been completely removed.
- 5.6.3 If necessary, perform additional grinding/filing, followed by repeating the application of approved etching solution.
- 5.7 When the arc burn has been completely removed, measure the area using an ultrasonic thickness gauge to determine remaining thickness of the pipe wall.
- 5.8 If the remaining wall thickness is equal to or greater than that required, the arc burn has been successfully removed.
- 5.9 If the resulting wall thickness is less than required, the portion of pipe that contained the arc burn shall be removed as a cylinder or repaired with an approved procedure listed in [REPR 1](#).

6.0 API Wall Thickness Tolerances

6.1 For pipe manufactured before 2009: API Reference Table 9

6.1.1 See [Appendix A](#) for Table 9 from API 5L, "Specifications for Line Pipe," 43rd Edition -- Used for pipe manufactured before 2009.

6.1.2 *Calculation Example:* ARC BURN on 6" OD PIPE: 0.375" W.T.

- Allowable wall thickness tolerance for API 5L Grade B pipe, 18" diameter and smaller is: +15% and --12.5%.
- Based on API requirement, for complete arc burn removal in this example, maximum material thickness that can be removed is calculated as follows
 - 3/8" wall thickness = 0.375"
 - 12.5% of 0.375 = 0.046"
- Therefore, maximum thickness that can be removed = 0.046"
- Hence, considering nominal wall thickness = 0.375"
 - Less the 12.5% of 0.375 = (0.046)
 - **Minimum wall thickness = 0.329**

6.2 For pipe manufactured in 2009 and later: API Reference Table 11

6.2.1 See [Appendix B](#) for Table 11 from API 5L, "Specifications for Line Pipe," 45th Edition - Used for pipe manufactured in 2009 and later.

End of Instructions.

Operator Qualification (OQ) Required?

YES

0801: Welding

Appendices

[Appendix A - API Table 9, 43rd Edition](#)

[Appendix B - API Table 11, 45th Edition](#)

Attachments

NONE.

Compliance Requirements

49 CFR Part 192 - Transportation of Natural and Other Gas by Pipeline: Minimum Federal Safety Standards

American Petroleum Institute (API) 5L, "Specification for Line Pipe", 45th Edition

American Petroleum Institute (API), Std 1104, "Standard for Welding Pipelines and Related Facilities", with Appendix B, "In-Service Welding"

Illinois Commerce Commission (ICC) Title 83: Public Utilities, Part 590, Minimum Safety Standards for Transportation of Gas and for Gas Pipeline Facilities, available online [here](#).

Reference Documents

[REPR 1 Repairs: Requirements](#)

[WELD 2.2 Welding: Welder Qualifications](#)

UNCONTROLLED IF PRINTED

WELD 2.3 Welding: Construction of Pipelines

Document Rescission

WELD 2.10 Welding: Arc Burn Removal, October 1, 2020

Revision Notes

Location of Changes	Summary of Changes
Paragraph 4.1.2	environment replaces atmosphere

Appendix A - API Wall Thickness Tolerances

A-1. Table 9 from API 5L, "Specifications for Line Pipe," 43rd Edition. **Reference Table for pipe manufactured before 2009.**

Table 9 - Tolerances for Wall Thickness

Table 9 - Tolerances for Wall Thickness			
Pipe Size (Inches)	Type of Pipe	Tolerance ¹ (Percent of Specified Wall Thickness)	
		Grade B or Lower	Grade X42 or Higher
≤ 2-7/8	All	+20.0% to -2.5%	+15.0% to -12.5%
> 2-7/8 and < 20	All	+15.0% to -12.5%	+15.0% to -12.5%
≥ 20	Welded	+17.5% to -12.5%	+19.5% to -8.0%
≥ 20	Seamless	+15.0% to -12.5%	+17.5% to -10.0%

1 Where negative tolerances smaller than those listed are specified by the purchaser, the positive tolerance shall be increased to the applicable total tolerance range in percent less the wall thickness negative tolerance.

Appendix B - API Wall Thickness Tolerances

B-1. Table 11 from API 5L, "Specifications for Line Pipe," 45th Edition (*measurement units flipped however*). **Reference Table for pipe manufactured in 2009 and later.**

Table 11 - Tolerances for Wall Thickness

Table 11 - Tolerances for Wall Thickness	
Wall Thickness <i>t</i> in. (mm)	Tolerances ^a in. (mm)
SMLS pipe^b	
≤ 0.157 in. (4.0 mm)	+ 0.024 in. (0.6 mm) - 0.020 in. (0.5 mm)
> 0.157 in. (4.0 mm) to < 0.984 in. (25.0 mm)	+ 0.150 <i>t</i> - 0.125 <i>t</i>
≥ 0.984 in. (25.0 mm)	+ 0.146 in (3.7 mm) or + 0.1 <i>t</i> , whichever is the greater - 0.120 in. (3.0 mm) or - 0.1 <i>t</i> , whichever is the greater
Welded pipe^{c, d}	
≤ 0.197 in. (5.0 mm)	± 0.020 in. (0.5 mm)
> 0.197 in. (5.0 mm) to < 0.591 in. (15.0 mm)	± 0.1 <i>t</i>
≥ 0.591 in. (15.0 mm)	± 0.060 in. (1.5 mm)

a If the purchase order specifies a minus tolerance for wall thickness smaller than the applicable value given in this table, the plus tolerance for wall thickness shall be increased by an amount sufficient to maintain the applicable tolerance range.

- b For pipe with $D \geq 14.000$ in. (355.6 mm) and $t \geq 20.984$ in. (25.0 mm), the wall thickness tolerance locally may exceed the plus tolerance for wall thickness by an additional $0.05 t$, provided that the plus tolerance for mass (see 9.14 in API 5L 44th edition) is not exceeded.
- c The plus tolerance for wall thickness does not apply to the weld area.
- d See 9.13.2 for additional restrictions.

WELDING

October 1, 2020

WELD 3 Useful Information**1.0 Purpose**

This document provides information welders and welding inspectors may find useful.

2.0 Scope

This document addresses the following:

[3.0 Target Audience](#)[4.0 Electrode Properties](#)[5.0 Pipe Properties](#)[6.0 Useful Formulas](#)[7.0 Decimal Equivalents](#)[8.0 Welder Identification System](#)[9.0 Copper Weld Cable Size](#)**3.0 Target Audience**

- Gas Tech Engineering (GTE)
- Gas Integrity Management Personnel
- Gas Engineers
- Gas Superintendents
- Gas Supervisors
- Gas Field Personnel - Welders
- Gas Construction Services Superintendents
- Gas Construction Services Supervisors
- Gas Contract Welding Inspectors
- Contract Gas Construction Company Supervisors
- Contract Gas Construction Company Welders
- Contract NDT Personnel

4.0 Electrode Properties

4.1 Strength Properties:

AWS Classification	Tensile Strength (PSI-Minimum)	Yield Strength (PSI-Minimum)	Elongation (%-Minimum)
E 6010	60,000	48,000	22
E 7010-G	70,000	60,000	22
E 8010-G	80,000	67,000	19
E 9010-G	90,000	77,000	17

Note: Values are for weld deposits in the as-welded condition.

4.2 SMAW Electrodes - Typical Amperage/Voltage Ranges:

LOW-HYDROGEN ELECTRODES (E7018, E8018, E9018)		
Diameter	Amperage	Voltage

UNCONTROLLED IF PRINTED

3/32"	80 - 100	20 - 23
1/8"	115 - 135	20 - 23
5/32"	140 - 190	20 - 23
CELLULOSE-COATED ELECTRODES (E6010, E7010-G, E8010-G, E91010-G)		
3/32"	50 - 70	22 - 25 (20-23 for Root Pass)
1/8"	85 - 120	22 - 25 (20-23 for Root Pass)
5/32"	115 - 160	22 - 28 (20-23 for Root Pass)
3/16"	140 - 190	25 - 28

Notes:

1. Voltage numbers presented herein are typical of measured values across the arc.
2. When measuring at machine terminals, voltage may be 2-3 volts higher due to circuit resistance.

4.3 GMAW Electrodes - Typical Voltage (short circuit transfer)

ER 70 S- 6	0.035 Solid Wire	Carbon Dioxide Shielding Gas
17 - 22 volts	18.5 volts at approximately 150 IPM is a good starting point	

5.0 Pipe Properties

5.1 Yield and Tensile Strength

API PIPE GRADE	YIELD STRENGTH (PSI - MINIMUM)	TENSILE STRENGTH (PSI - MINIMUM)
B	35,000	60,000
X42	42,000	60,000
X46	46,000	63,000
X52	52,000	66,000
X56	56,000	71,000
X60	60,000	75,000
X65	65,000	77,000
X70	70,000	82,000
X801	80,000	90,000

Notes:

1. Pipe Grade X80 has a maximum tensile strength of 120,000 PSI.
2. There is no maximum value for the other pipe grades unless specified by purchase order.

5.2 Pipe Sizes and Wall Thickness -- Schedule 5S thru Schedule 80:

COMMERCIAL PIPE SIZES and WALL THICKNESSES ASME B36.10 and B36.19 (inches)											
Nominal Pipe Size (NPS)	Outside Diameter (inches)	SCH 5S	SCH 10S	SCH 10	SCH 20	SCH 30	STD	SCH 40	SCH 60	XS	SCH 80
1	1.315	0.065	0.109	---	---	---	0.133	0.133	---	0.179	0.179

1-1/2	1.900	0.065	0.109	---	---	---	0.145	0.145	---	0.200	0.200
2	2.375	0.065	0.109	---	---	---	0.154	0.154	---	0.218	0.218
2-1/2	2.875	0.083	0.120	---	---	---	0.203	0.203	---	0.276	0.276
3	3.500	0.083	0.120	---	---	---	0.216	0.216	---	0.300	0.300
3-1/2	4.000	0.083	0.120	---	---	---	0.226	0.226	---	0.318	0.318
4	4.500	0.083	0.120	---	---	---	0.237	0.237	---	0.337	0.337
5	5.563	0.109	0.134	---	---	---	0.258	0.258	---	0.375	0.375
6	6.625	0.109	0.134	---	---	---	0.280	0.280	---	0.432	0.432
8	8.625	0.109	0.148	---	0.250	0.277	0.322	0.322	0.406	0.500	0.500
10	10.750	0.134	0.165	---	0.250	0.307	0.365	0.365	0.500	0.500	0.594
12	12.750	0.156	0.180	---	0.250	0.330	0.375	0.406	0.562	0.500	0.688
14OD	14.000	0.156	0.188	0.250	0.312	0.375	0.375	0.438	0.594	0.500	0.750
16OD	16.000	0.165	0.188	0.250	0.312	0.375	0.375	0.500	0.656	0.500	0.844
18OD	18.000	0.165	0.188	0.250	0.312	0.438	0.375	0.562	0.750	0.500	0.938
20OD	20.000	0.188	0.218	0.250	0.375	0.500	0.375	0.594	0.812	0.500	1.031
22OD	22.000	0.188	0.218	0.250	0.375	0.500	0.375	---	0.875	0.500	1.125
24OD	24.000	0.218	0.250	0.250	0.375	0.562	0.375	0.688	0.969	0.500	1.218
26OD	26.000	---	---	0.312	0.500	---	0.375	---	---	0.500	---
28OD	28.000	---	---	0.312	0.500	0.625	0.375	---	---	0.500	---
30OD	30.000	0.250	0.312	0.312	0.500	0.625	0.375	---	---	0.500	---
32OD	32.000	---	---	0.312	0.500	0.625	0.375	0.688	---	0.500	---
34OD	34.000	---	---	0.312	0.500	0.625	0.375	0.688	---	0.500	---
36OD	36.000	---	---	0.312	0.500	0.625	0.375	0.750	---	0.500	---

5.3 Pipe Sizes and Wall Thickness -- Schedule 100 thru XX Strong:

COMMERCIAL PIPE SIZES and WALL THICKNESSES ASME B36.10 and B36.19 (inches)						
Nominal Pipe Size (NPS)	Outside Diameter (inches)	SCH 100	SCH 120	SCH 140	SCH 160	XXS
1	1.315	---	----	----	0.250	0.358
1-1/2	1.900	---	----	----	0.281	0.400
2	2.375	---	----	----	0.344	0.436
2-1/2	2.875	---	----	----	0.375	0.552
3	3.500	---	----	----	0.438	0.600
3-1/2	4.000	---	----	----	----	----
4	4.500	---	0.438	----	0.531	0.674
5	5.563	---	0.500	----	0.625	0.750
6	6.625	---	0.562	----	0.719	0.864
8	8.625	0.594	0.719	0.812	0.906	0.875
10	10.750	0.719	0.844	1.000	1.125	1.000
12	12.750	0.844	1.000	1.125	1.312	1.000
14OD	14.000	0.938	1.094	1.250	1.406	---
16OD	16.000	1.031	1.219	1.438	1.594	---
18OD	18.000	1.156	1.375	1.562	1.781	---
20OD	20.000	1.281	1.500	1.750	1.969	---
22OD	22.000	1.375	1.625	1.875	2.125	---

UNCONTROLLED IF PRINTED

24OD	24.000	1.531	1.812	2.062	2.344	---
26OD	26.000	---	---	---	---	---
28OD	28.000	---	---	---	---	---
30OD	30.000	---	---	---	---	---
32OD	32.000	---	---	---	---	---
34OD	34.000	---	---	---	---	---
36OD	36.000	---	---	---	---	---

6.0 Useful Formulas

6.1 Design Formula for Steel Pipe (49 CFR §192.105):

$$P = (2 St/D) \times F \times E \times T$$

Where,

P = Design pressure in psig.

S = Yield strength in psi determined in accordance with §192.107.

t = Nominal wall thickness of pipe in inches.

D = Nominal outside diameter of pipe in inches.

F = Design factor determined in accordance with §192.111.

(Assume F=1 here)

E = Longitudinal joint factor determined in accordance with §192.113.

(Assume E=1 here)

T = Temperature derating factor determined in accordance with §192.115.

(Assume T=1 here)

6.1.1 Hoop Stress:

$$\text{Hoop Stress } S \text{ [psi]} = \frac{P \times D}{2 \times t}$$

Where,

P = operating pressure, D = nominal outside diameter, and t = wall thickness.

6.1.2 Determine if Pipeline is Operating at 20% or More of SMYS:

For the specific pipeline system, calculate 20% of the pipe SMYS to compare with pipeline operation:

$$X = 20\% \text{ SMYS} = \frac{(0.20) \times (2) \times (\text{Yield Strength}) \times t}{D}$$

Where,

Yield Strength is the SMYS for the pipe grade (e.g., Gr X42 pipe has Yield Strength = 42,000 psi), t = wall thickness, and D = outside diameter.

If the actual pipeline operating pressure is equal to or greater than X, then the pipeline system is operating at or above 20% of SMYS and the line is classified as a transmission facility (49 CFR §192.3).

6.1.3 **Actual % SMYS** (for a given pressure, in psi):

$$\% \text{ SMYS} = \frac{P \times (D/2t)}{\text{Yield Strength}}$$

Where,

P is operating pressure, D = outside diameter, t = wall thickness of pipe, and Yield Strength is the SMYS for the pipe grade (e.g., Gr X42 pipe has Yield Strength = 42,000 psi).

6.1.4 **Diameter to Wall Thickness Ratio:**

$$\text{Diameter to Wall Thickness Ratio} = D/t$$

Where,

D = outside diameter and t = wall thickness of pipe.

6.2 Welding Related Formulas

6.2.1 **Power Loss Formula:**

$$\text{Power Loss PL [Watts]} = (V_1 - V_2) \times I$$

Where,

V1 = Voltage at terminals, V2 = Voltage at electrode holder (across arc), and I = Current (Amperage).

Note: Select weld cable and ground (work) connections so that the voltage drop in the welding circuit *does not exceed 4 volts*.

6.2.2 **Travel Speed:**

$$\text{Travel Speed (inches per minute)} = \frac{\text{Length of Weld} \times (60 \text{ sec/min})}{\text{Weld Time}}$$

Where,

Length of Weld is inches, and Weld Time is seconds.

6.2.3 **Heat Input of Each Weld Pass:**

$$\text{Heat Input [Joules per inch]} = \frac{A \times V \times (60 \text{ sec/min})}{\text{Travel Speed}}$$

Where,

A = amps, V = volts, 60 is a constant (sec/min), and Travel Speed is inches per minute.

6.2.4 **Ultimate Tensile Strength of Weld:**

$$\text{Ultimate Tensile Strength } S \text{ [psi]} = \frac{P}{A}$$

Where,

P = load (lbs) and A = cross-sectional area of the coupon before testing (width x thickness) in square inches.

6.2.5 Percent Elongation of Specimen:

$$\% \text{ Elongation} = \frac{\text{Final Length} - \text{Original Length}}{\text{Original Length}} \times 100\%$$

Notes:

1. Before bending or tensile testing, lightly center punch two gauge marks 2" apart, at approximately the center of the sample, with the weld in the center of the 2" gauge length.
2. After testing, put pieces together and measure the distance between gauge marks.
3. Calculate percent elongation using above formula.

6.2.6 Percent Reduction of Tensile Specimen:

$$\% \text{ Reduction} = \frac{\text{Original Area} - \text{Final Area}}{\text{Original Area}} \times 100\%$$

Notes:

1. Measure and record original cross-section of specimen.
2. After testing, put pieces together and measure the cross-sectional area of the necked-down portion of broken sample.
3. Calculate percent reduction using above formula.

6.3 Figure Fitting "Take Off" Measurement:

6.3.1 90° Standard Radius "takeoff" is 1.5 x pipe diameter (Example: 4" 90° has a 6" takeoff).

6.3.2 45° Standard Radius "takeoff" is pipe diameter x .625 (Example: 4" 45° has a 2.5" takeoff).

7.0 Decimal Equivalents

Fractions (inch)		Decimal (inch)	Millimeters	Fractions (inch)		Decimal (inch)	Millimeters
	1/64	.01563	0.397		33/64	.51563	13.097
	1/32	.03125	0.794		17/32	.53125	13.494
	3/64	.04688	1.191		35/64	.54688	13.891
1/16		.0625	1.588	9/16		.5625	14.288
	5/64	.07813	1.984		37/64	.57813	14.684
	3/32	.09375	2.381		19/32	.59375	15.081
	7/64	.10938	2.778		39/64	.60938	15.478
1/8		.125	3.175	5/8		.625	15.785
	9/64	.14063	3.572		41/64	.64063	16.272

	5/32		.15625	3.969		21/32		.65625	16.669
		11/64	.17188	4.366			43/64	.67188	17.066
3/16			.1875	4.763	11/16			.6875	17.463
		13/64	.20313	5.159			45/64	.70313	17.859
	7/32		.21875	5.556		23/32		.71875	18.256
		15/64	.23438	5.953			47/64	.73438	18.653
1/4			.250	6.350	3/4			.750	19.050
		17/64	.26563	6.747			49/64	.76563	19.447
	9/32		.28125	7.144		25/32		.78125	19.844
		19/64	.29688	7.541			51/64	.79688	20.241
5/16			.3125	7.938	13/16			.8125	20.638
		21/64	.32813	8.334			53/64	.82813	21.034
	11/32		.34375	8.731		27/32		.84375	21.431
		23/64	.35938	9.128			55/64	.85938	21.828
3/8			.375	9.525	7/8			.875	22.225
		25/64	.39063	9.922			57/64	.89063	22.622
	13/32		.40625	10.319		29/32		.90625	23.019
		27/64	.42188	10.716			59/64	.92188	23.416
7/16			.4375	11.113	15/16			.9375	23.813
		29/64	.45313	11.509			61/64	.95313	24.209
	15/32		.46875	11.906		31/32		.96875	24.606
		31/64	.48438	12.303			63/64	.98438	25.003
1/2			.500	12.700	1			1.00000	25.400

8.0 Welder Identification System

Welder Identification System

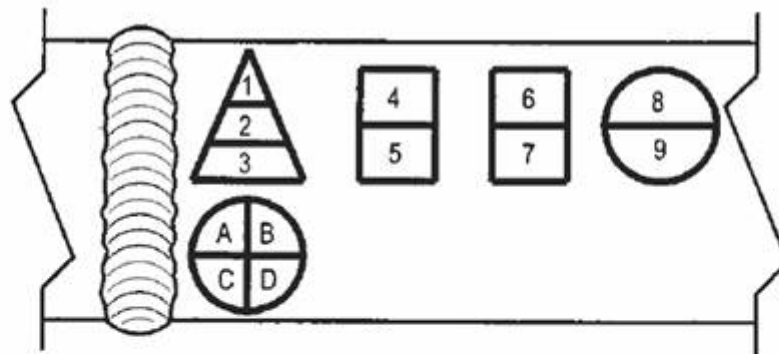

- LEGEND**
- | | |
|---|----------------------------------|
| 1. Root Pass – Ditch Side | Option for 4 Root Pass Welders |
| 2. Root Pass – Top of Pipe (If 3 Bead Welders Are Used) | A. Root Pass – Ditch Side Top |
| 3. Root Pass – ROW Side | B. Root Pass – ROW Side Top |
| 4. Hot Pass – Ditch Side | C. Root Pass – Ditch Side Bottom |
| 5. Hot Pass – ROW Side | D. Root Pass – ROW Side Bottom |
| 6. Second Hot Pass or Hot Filler – Ditch Side | |
| 7. Second Hot Pass or Hot Filler – ROW Side | |
| 8. Fill/Cap – Ditch Side | |
| 9. Fill/Cap – ROW Side | |

9.0 Copper Weld Cable Size

COPPER WELD CABLE SIZE GUIDE FOR SMAW WELDING 60% DUTY CYCLE

UNCONTROLLED IF PRINTED

Amperage	50 Ft.	100 Ft.	150 Ft.	200 Ft.	300 Ft.	400 Ft.
75	6	6	4	3	2	1
100	4	4	3	2	1	1/0
150	3	3	2	1	2/0	3/0
200	2	2	1	1/0	3/0	4/0
250	2	2	1/0	2/0	4/0	-----
300	1	1	2/0	3/0	-----	-----

Note: The length of cable is the length of the electrode lead plus the ground or work lead.

End of Instructions.

Operator Qualification (OQ) Required?

NO.

Appendices

NONE.

Attachments

NONE.

Compliance Requirements

49 CFR Part 192, specifically §§ 192.3, 192.105, 192.107

Reference Documents

[WELD 2.3 Welding: Construction of Pipelines](#)

American Society of Mechanical Engineers (ASME) B36.10, Welded and Seamless Wrought Steel Pipe

American Society of Mechanical Engineers (ASME) B36.19, Stainless Steel Pipe

Document Rescission

WELD 3.02 Welding: Useful Information, January 1, 2016.

Revision Notes

Location of Changes	Summary of Changes
Not applicable.	This is a new document.

WELDING

December 15, 2021

WELD 4 Forms and Reference Materials

Click on the links below to open the documents.

Forms

1. [Daily Radiographic Report](#)
2. [Ultrasonic Thickness Record](#)
3. [Welder Certification Card](#)

References*A. AIC Transmission & Distribution*

1. [SMAW - Ref 01 - Fixed Butt Weld Matrix](#)
2. [SMAW - Ref 02 - Ameren-001 Rev 3](#)
3. [SMAW - Ref 03 - Ameren-002 Rev 5](#)
4. [SMAW - Ref 04 - Ameren-003 Rev 3](#)
5. [SMAW - Ref 05 – Ameren-222 Rev 3](#)
6. [SMAW - Ref 63 - Ameren-009-HW Rev 1](#)
7. [SMAW - Ref 64 - Ameren-010-HW Rev 1](#)
8. [SMAW - Ref 65 - Ameren-011-HW Rev 1](#)
9. [SMAW - Ref 10 - Fixed Fillet & Branch Weld Matrix](#)
10. [SMAW - Ref 11 - Ameren-F01 Rev 6](#)
11. [SMAW - Ref 12 - Ameren-F02 Rev 4](#)
12. [SMAW - Ref 13 - Ameren-F03 Rev 6](#)
13. [SMAW - Ref 14 - Ameren-F04 Rev 5](#)
14. [SMAW - Ref 15 - Ameren-F05 Rev 4](#)
15. [SMAW - Ref 16 - Ameren-F06 Rev 4](#)
16. [SMAW - Ref 17 - Ameren-F07 Rev 4](#)
17. [SMAW - Ref 18 - Ameren-F08 Rev 6](#)
18. [SMAW - Ref 19 - Ameren-F09 Rev 4](#)
19. [SMAW - Ref 20 - Ameren-F10 Rev 3](#)
20. [SMAW - Ref 66 - Ameren-F11-HW Rev 1](#)
21. [SMAW - Ref 21 - Rolled Butt Weld Matrix](#)
22. [SMAW - Ref 22 - Ameren-001R Rev 3](#)
23. [SMAW - Ref 23 - Ameren-002R Rev 3](#)

UNCONTROLLED IF PRINTED

24. [SMAW - Ref 24 - Ameren-003R Rev 3](#)
25. [SMAW - Ref 27 - Ameren-006R Rev 3](#)
26. [SMAW - Ref 28 - Ameren-007R Rev 3](#)
27. [SMAW – Ref 69 – Ameren-008R](#)
28. [**SMAW - Ref 29 - Rolled Fillet & Branch Weld Matrix**](#)
29. [SMAW - Ref 30 - Ameren-F01R Rev 4](#)
30. [SMAW - Ref 31 - Ameren-F02R Rev 4](#)
31. [SMAW - Ref 32 - Ameren-F03R Rev 4](#)
32. [SMAW - Ref 33 - Ameren-F04R Rev 4](#)
33. [**GMAW - Ref 34 - Fixed Butt Weld Matrix**](#)
34. [GMAW - Ref 35 - Ameren-W001 Rev 3](#)
35. [GMAW - Ref 36 - Ameren-W002 Rev 3](#)
36. [GMAW - Ref 67 - Ameren-W007-HW Rev 1](#)
37. [**GMAW - Ref 40 - Fixed Fillet & Branch Weld Matrix**](#)
38. [GMAW - Ref 41 - Ameren-WF01 Rev 4](#)
39. [GMAW - Ref 42 - Ameren-WF02 Rev 4](#)
40. [GMAW - Ref 43 - Ameren-WF03 Rev 6](#)
41. [GMAW - Ref 44 - Ameren-WF04 Rev 6](#)
42. [GMAW - Ref 45 - Ameren-WF05 Rev 4](#)
43. [GMAW - Ref 46 - Ameren-WF06 Rev 4](#)
44. [GMAW - Ref 68 - Ameren-WF08-HW Rev 1](#)
45. [**GMAW - Ref 48 - Rolled Butt Weld Matrix**](#)
46. [GMAW - Ref 49 - Ameren-W001R Rev 3](#)
47. [GMAW - Ref 50 - Ameren-W002R Rev 3](#)
48. [GMAW - Ref 53 - Ameren-W006R Rev 3](#)
49. [**GMAW - Ref 54 - Rolled Fillet & Branch Weld Matrix**](#)
50. [GMAW - Ref 55 - Ameren-WF01R Rev 4](#)
51. [GMAW - Ref 56 - Ameren-WF02R Rev 4](#)
52. [GMAW - Ref 57 - Ameren-WF03R Rev 4](#)
53. [**SMAW - Ref 58 – In-Service Weld Matrix**](#)
54. [SMAW - Ref 59 - Ameren IS01 Rev 3](#)
55. [De Felsko PostTector UTG Full Guide](#)

B. AIC Gas Storage Field - Well Head WPSs

- SF 1. [GS WH 01 H-40 to J-55 WPS BUTT ASME IX](#)
- SF 2. [GS WH 02 J-55 to J-55 WPS BUTT ASME IX](#)
- SF 3. [GS WH 03 K-55 to K-55 WPS BUTT ASME IX](#)
- SF 4. [GS WH 04 K-55 to J-55 WPS BUTT ASME IX](#)
- SF 5. [GS WH 05 K-55 to H-40 WPS BUTT ASME IX](#)
- SF F01. [GS WH F01 K-55 to 4130 WPS Fillet ASME IX](#)
- SF F02. [GS WH F02 J-55 to 4130 WPS Fillet ASME IX](#)
- SF F03. [GS WH F03 H-40 to 4130 WPS Fillet ASME IX](#)

End of Section.

Document Rescission

WELD 4 Welding: Forms and Reference Materials, October 1, 2020

Revision Notes

Location of Changes	Summary of Changes
Reference Materials	The GMAW and SMAW weld procedures (WPSs) have been reformatted.

WIGE-Working in Gaseous Environment

WORKING IN GASEOUS ENVIRONMENT

April 1, 2023

WIGE 0 Table of Contents

[WIGE 1 Working In Gaseous Environment: Requirements](#)

- Section 1.0 Purpose
- Section 2.0 Scope
- Section 3.0 Target Audience
- Section 4.0 General
- Operator Qualification (OQ)
- Compliance Requirements
- Reference Documents
- Document Rescission

[WIGE 2.1 Working In Gaseous Environment: Hazardous Environment](#)

- Section 1.0 Purpose
- Section 2.0 Scope
- Section 3.0 Target Audience
- Section 4.0 General
- Section 5.0 Identifying a Hazardous Outdoor Environment Due to Gas-In-Air
- Section 6.0 Safe Zone
- Section 7.0 Working in a Hazardous Outdoor Environment Due to Gas-In-Air
- Section 8.0 Shut Down Options When Working In a Hazardous Environment Due to Gas-In-Air
- Operator Qualification (OQ)
- Compliance Requirements
- Reference Documents
- Document Rescission

[WIGE 2.2 Working In Gaseous Environment: Personal Protective Equipment](#)

- Section 1.0 Purpose
- Section 2.0 Scope
- Section 3.0 Target Audience
- Section 4.0 General

UNCONTROLLED IF PRINTED

Section 5.0 Tools & Equipment SharePoint Site

Section 6.0 PPE Specifications

Section 7.0 Level 1 PPE Availability, Care, and Storage

Section 8.0 Level 2 PPE Availability, Care, and Storage

Section 9.0 Inspection

Operator Qualification (OQ)

Compliance Requirements

Reference Documents

Document Rescission

WIGE 3 Forms and Reference Materials

Reference Materials

End Table of Contents.

Document Rescission

WWBG 0 Table of Contents Working with Blowing Gas, April 1, 2021.

Revision Notes

Location of Changes	Summary of Changes
WIGE 3 - Forms and Reference Materials	New – RKI GX-3R Manual, personal air monitor.

WORKING IN GASEOUS ENVIRONMENT

April 1, 2021

WIGE 1 Requirements

1.0 Purpose

This document describes Ameren Illinois (AIC) requirements per 29 CFR §1910.132 for working in or near blowing gas in an outdoor environment that is considered hazardous due to gas-in-air.

2.0 Scope

This document addresses the following:

[3.0 Target Audience](#)

[4.0 General](#)

3.0 Target Audience

- Emergency Responders
- Gas Field Personnel
- Gas Storage Field Personnel
- Gas Storage Supervisors
- Gas Supervisors
- Gas Tech Services (GTS) Personnel
- Gas Tech Services (GTS) Supervisors
- Safety Department Manager

4.0 General

4.1 Basic properties of natural gas:

4.1.1 Flammable.

1. Natural gas ignition temperature range: 1000 - 1200 degrees Fahrenheit (°F).
2. Natural gas burns with a flame temperature of 2200 °F.

Even an ignition of short duration (flash) will cause severe burns to exposed flesh.

4.1.2 Lighter than Air.

4.1.3 Colorless.

Blowing natural gas may be visible under certain atmospheric and gas pressure conditions.

4.1.4 Odorless and tasteless.

- Unodorized natural gas may retain odors accumulated from its production or storage formation.
- Odorized natural gas has a distinctive foul odor often described as rotten eggs, onions, or hydrogen sulfide.

4.1.5 Non-toxic.

- Natural gas will displace oxygen in the atmosphere leading to possible suffocation.
- Personnel not properly protected may inhale a potentially flammable concentration of natural gas.
- If an ignition occurs, the flame may follow the airway passages into the lungs resulting in potentially fatal respiratory system injury.

4.2 A hazardous outdoor environment is a gas-in-air concentration equal to or greater than 30% LEL (1.5% natural gas).

4.3 Gas field personnel shall monitor gas-in-air readings with a gas detection instrument when gas-in-air is capable of causing harm to life and/or property by ignition or suffocation.

End of Instructions.

Operator Qualification (OQ) Required?

NO.

Appendices

NONE.

Attachments

NONE.

Compliance Requirements

29 CFR §1910.132 Personal Protective Equipment.

Reference Documents

NONE.

Document Rescission

WWBG 1 Working with Blowing Gas - Requirements, October 1, 2020.

Revision Notes

UNCONTROLLED IF PRINTED

Location of Changes	Summary of Changes
Section Title	Working In Gaseous Environment: Requirements
1.0 Purpose	Modified to working in an outdoor environment that is considered hazardous due to gas-in-air.
Subsection 4.2	Defined hazardous environment – gas-in-air concentration equal to or greater than 30% LEL. Defined hazardous environment – gas-in-air concentration equal to or greater than 30% LEL.
Subsection 4.3	Gas field personnel shall monitor gas-in-air readings with a gas detection instrument when gas-in-air is capable of causing harm to life and/or property by ignition or suffocation.

WORKING IN GASEOUS ENVIRONMENT

April 1, 2023

WIGE 2.1 Hazardous Environment

1.0 Purpose

This document describes Ameren Illinois (AIC) requirements per 29 CFR §1910.132 for gas field personnel to avoid potential injury when working in or near blowing gas in an outdoor environment that is considered hazardous due to gas-in-air. For indoor situations, see [LEAK 2.1](#).

2.0 Scope

This document addresses the following:

[3.0 Target Audience](#)[4.0 General](#)[5.0 Identifying a Hazardous Outdoor Environment Due to Gas-In-Air](#)[6.0 Safe Zone](#)[7.0 Working in a Hazardous Outdoor Environment Due to Gas-In-Air](#)[8.0 Shut Down Options When Working in a Hazardous Outdoor Environment Due to Gas-In-Air](#)**3.0 Target Audience**

- Gas Field Personnel
- Gas Storage Field Personnel
- Gas Storage Supervisors
- Gas Supervisors
- Gas Tech Services (GTS) Supervisors
- Gas Tech Services (GTS) Personnel
- Safety Department Manager

4.0 General

4.1 Gas-in-air readings are taken with a **CGI** within the breathing zone (approximately 10 inches from the mouth and nose) of person closest to a gaseous environment.

4.1.1 An approved hands-free air monitor can be used in-lieu of a CGI for monitoring the work area environment. See [WIGE 3](#) for manufacturer's instructions.

4.1.2 Follow the manufacturer's instructions for operating, calibrating, and maintaining.

4.2 Parking and approach considerations:

4.2.1 Gas field personnel (personnel that are Operator Qualified in the required covered tasks to investigate a gas leak and/or repair a gas leak.) See appropriate sub-part of Emergency Plan under [EMER 2.4](#).

4.2.2 Non-gas field personnel including Emergency Responders (personnel that are not Operator Qualified in the required covered tasks to investigate a gas leak and/or repair of a gas leak.) See [EMER 2.3](#).

4.3 Gas field personnel shall:

4.3.1 Protect themselves from traffic and other hazards while working in or around hazardous environment.

UNCONTROLLED IF PRINTED

1. See [WIGE 2.2](#) for details of Level 1 and Level 2 Personal Protective Equipment (PPE).
- 4.3.2 Ensure that a dry chemical (A, B, C) fire extinguisher is present near the worksite while working in a gaseous environment.
 1. A minimum 20 pound fire extinguisher is required when workers are in Level 2 PPE. The fire extinguisher shall be discharge tested upwind of the work-site.
 2. A 10 pound fire extinguisher is acceptable when workers are in standard work clothes or Level 1 PPE.

5.0 Identifying a Hazardous Outdoor Environment Due to Gas-In-Air

- 5.1 The outdoor environment is considered hazardous at any work location where there is a gas-in-air reading equal to or greater than 30% LEL (1.5% natural gas):
- 5.2 Locations where the environment may be considered hazardous due to gas-in-air include:
 - 5.2.1 Damage to a gas facility such as:
 1. Main
 2. Service line without an EFV activation
 3. Regulator station.
 2. Farm tap.
 3. Meter set.
 4. Riser.
 - 5.2.2 Changing a meter valve "on the fly".
 - 5.2.3 Working adjacent to a blowing relief valve.
- 5.3 Locations where the environment *would not* be considered hazardous due to gas-in-air include:
 - 5.3.1 Purging a service or main through a valve or grounded squeeze tool that is vented to the environment through a metallic stack that is grounded. See [PURG 2](#).
 - 5.3.2 Purging gas from a stopper.
 - 5.3.3 Igniting and burning small volumes of gas purposely released as steel welding operations are performed.
- 5.4 Consider the following options to minimize exposure to working in a hazardous environment:
 - 5.4.1 Use valves which are located in a non-hazardous environment.
 - 5.4.2 Excavate and squeeze pipe in a non-hazardous environment.
 - 5.4.3 Excavate and use control fittings in a non-hazardous environment.
 - 5.4.4 Work above grade and utilize above grade tools when possible.
 - 5.4.5 Work upwind of gas-in-air when possible.

5.4.6 Vent gas-in-air or create an engineering approved barrier between blowing gas and gas field personnel to minimize gas-in-air readings where work is to be performed.

5.5 Proper positioning of gas field personnel while working in a hazardous environment due to gas-in-air can greatly reduce the potential for severe burns and injuries in the event of an ignition.

6.0 Safe Zone

6.1 Gas Field Personnel shall:

6.1.1 Define the limits of the hazardous environment by using a gas detection instrument.

6.1.2 After the extent of the gas migration is determined or additional gas personnel have arrived to assist, establish a safe zone perimeter if there is hazardous environment due to gas-in-air.

6.1.3 In establishing the safe zone perimeter, check the area for gas-in-air concentrations less than 30% LEL to ensure the outer limits of the safe zone perimeter have a non-hazardous environment.

6.1.4 Consider the amount and pressure of gas being released plus wind speed and direction when establishing the outer limits of the safe zone perimeter.

6.1.5 If there is a hazardous environment due to gas-in-air, monitor the perimeter of the safe zone to ensure the environment outside the safe zone remains non-hazardous.

1. Adjust the safe zone perimeter to remain non-hazardous.

Perimeter adjustment is particularly needed if there is a change in wind direction or wind speed.

6.1.6 Visually mark the perimeter of the safe zone using barricades, signs, cones, fencing, marking paint, and/or warning tape.

6.1.7 Monitor the atmosphere inside and around the safe zone.

1. If the gas detection instrument reading within the safe zone indicates a gas-in-air reading equal to or greater than 60% LEL (3% natural gas),

1 a. Wear Level 2 PPE in that area.

6.2 Any personnel inside the safe zone shall wear at a minimum Level 1 PPE until there is no longer a hazardous environment.

6.3 Emergency Responders and non-gas field personnel dispatched to make an affected area safe shall maintain a safe zone perimeter with minimum 20-foot radius from location of suspected cause of gas-in-air. See [EMER 2.3](#).

Emergency Responders and non-gas field personnel usually do not have access to a gas detection instrument or Level 1 PPE.

7.0 Working in a Hazardous Outdoor Environment Due to Gas in Air

7.1 Gas field personnel shall:

- 7.1.1 If working in an excavation is required, review [EXCV 2.9](#) and use it in conjunction with WIGE procedures.
- 7.1.2 Refer to [WIGE 2.2](#) for listing of required Level 1 and Level 2 PPE.
- 7.1.3 Have the option to define the limits of the non-hazardous environment when the gas-in-air readings are less than 30% LEL without the Level 1 PPE.
- 7.1.4 Suit-up in Level 1 PPE if a gas detection instrument gas-in-air reading of 30% LEL (1.5% natural gas) to 60% LEL (3.0% natural gas) is measured in the breathing zone where the work is to be performed.
- 7.1.5 Suit-up in Level 2 PPE if a gas detection instrument gas-in-air reading equal to or greater than 60% LEL (3.0% natural gas) is measured in the breathing zone where the work is to be performed.
- 7.1.6 Evaluate the proposed work area for the ability to retrieve personnel in the event a rescue is necessary.
 - 1. If personnel cannot be effectively removed from the area using a lifeline, personnel shall not enter the area.

7.2 When gas field personnel are suited up in Level 2 PPE, additional gas field personnel suited up in proper level of PPE as described in [Subsection 7.1](#) shall perform support functions such as:

- 7.2.1 Manning fire extinguishers and discharge testing them prior to work being performed.
- 7.2.2 Manning safety harness lifelines: minimum 2 people per worker.
- 7.2.3 Manning the supplied air equipment.
- 7.2.4 Monitoring environment of the work area and safe zone with a gas detection instrument.
- 7.2.5 Supplying tools, material, and equipment to workers.
- 7.2.6 Being the designated back-up person suited-up in Level 2 PPE.

8.0 Shut Down Options When Working in a Hazardous Outdoor Environment Due to Gas-In-Air

- 8.1 If determined that gas field personnel are to work in a hazardous outdoor environment, options are listed below to shut down the source of gas-in-air. Due to hazardous variables of natural gas, other options can be considered.

Accidental ignition is a risk associated with gas-in-air mixtures. Be aware of potential ignition sources including mechanical sparking/arcing, static arcing, lightning, and non-intrinsically safe devices. See [ACIG](#).

8.1.1 Above grade:

1. Turning an inline valve on service/main to the off position
 2. Turning an above grade meter valve or valve at farm tap to the off position.
 3. Utilizing steel squeeze off tool. See [STLP 2.3 Steel Pipe Squeeze-Off](#).
 4. Utilizing above grade mustang squeeze off tool. See [POLY 2.2 Section 6.0](#)
 5. Installing an expander plug if operating pressure is 60 psig or less.
 6. Installing a stainless steel band clamp. See [REPR 1 Subsection 6.8](#).
 7. Tightening fittings and/or bolts. For flanges, see [STLP 3.3, Section 6.0](#).
- 8.1.2 Below grade:
1. Turning an inline valve on the service/main to the off position.
 2. Turning an above grade meter valve or valve at farm tap to the off position.
 3. Utilizing steel squeeze off tool. See [STLP 2.3 Steel Pipe Squeeze-Off](#).
 4. Utilizing above grade mustang squeeze off tool. See [POLY 2.2 Section 6.0](#)
 5. Utilizing a grounded hand held squeeze off tool. See [POLY 2.2](#).
 6. Installing a stainless steel band clamp. See [REPR 1 Subsection 6.8](#).
 7. Tightening fittings and/or bolts. For flanges, see [STLP 3.3, Section 6.0](#).
 8. Installing a Plidco Split+Sleeve. See [REPR 2.2](#)
 9. Install a tapered screw plug. See [REPR 1 Paragraph 8.2.3](#).

End of Instructions.

Operator Qualification (OQ) Required?

NO.

Appendices

NONE.

Attachments

NONE.

Compliance Requirements

29 CFR §1910.132 Occupational Safety and Health Standards - Personal Protective Equipment.

Reference Documents

[EMER 2.3 Emergency Plan: Emergency Responder](#)

[EMER 2.4 Emergency Plan: Gas Field Personnel - General](#)

[EXCV 2.9 Excavation Safety: Working in Hazardous Atmosphere](#)

UNCONTROLLED IF PRINTED

[LEAK 2.1 Leak Management: Indoor Investigations](#)

[POLY 2.2 Polyethylene Pipe: Squeeze Off](#)

[PURG 2 Purging: Methods](#)

[WIGE 2.2 Working with Blowing Gas: Personal Protective Equipment](#)

Document Rescission

[WIGE 2.1 Working in Gaseous Environment: Hazardous Environment](#), April 1, 2021

Revision Notes

Location of Changes	Summary of Changes
Subsection 4.1	<p>"CGI" replaced "gas detection instrument"</p> <p>4.1.1 An approved hands-free air monitor can be used in-lieu of a CGI for monitoring the work area environment. See WIGE 3 for manufacturer's instructions</p> <p>4.1.2 Follow manufacturer's instructions for operating, calibrating and maintaining.</p>
Paragraph 7.1.1	Updated reference link to EXCV 2.9 from EXCV 2.09
Paragraph 8.1.1, Item 3. – Above grade	Added link to STLP 2.3 Steel Pipe Squeeze-Off
Paragraph 8.1.2, Item 3 – Below grade	Added link to STLP 2.3 Steel Pipe Squeeze-Off
Document Rescission	Updated – WIGE 2.1 Working In Gaseous Environment

WORKING IN GASEOUS ENVIRONMENT

May 15, 2022

WIGE 2.2 Personal Protective Equipment**1.0 Purpose**

This document describes Ameren Illinois (AIC) requirements per 29 CFR §1910.132 for personal protective equipment to be worn by gas field personnel when working in an outdoor environment that is considered hazardous due to gas-in-air. For indoor situations, see LEAK 2.1.

2.0 Scope

This document addresses the following:

[3.0 Target Audience](#)**[4.0 General](#)****[5.0 Tools & Equipment SharePoint Site](#)****[6.0 PPE Specifications](#)****[7.0 Level 1 PPE Availability, Care, and Storage](#)****[8.0 Level 2 PPE Availability, Care, and Storage](#)****[9.0 Inspection](#)****3.0 Target Audience**

- Gas Field Personnel
- Gas Standards and Procedures
- Gas Storage Field Personnel
- Gas Storage Supervisors
- Gas Supervisors
- Gas Tech Services (GTS) Personnel
- Gas Tech Services (GTS) Supervisors
- Safety Department Manager

4.0 General

4.1 AIC continually evaluates and approves Personal Protective Equipment (PPE) products.

4.1.1 Gas Standards and Procedures group in conjunction with Safety Department evaluate and approve PPE products.

4.1.2 Once approved, PPE products are added to the Tools & Equipment on the Gas Standards and Procedures SharePoint Site: <https://ameren.sharepoint.com/sites/GasIL/Materials/>.

This edition of WIGE 2.2 may not list all approved PPE products due to time lag between adding approved PPE products to Gas Standards and Procedures SharePoint Site and the next edition of WIGE 2.2. See [Section 5.0](#).

4.1.3 To ensure gas field personnel are supplied with correct PPE, specifications and manufacturer information are included in Table1 and on the Gas Standards and Procedures SharePoint site (see [Paragraph 5.1.1](#)).

UNCONTROLLED IF PRINTED

Table 1: Currently Approved Personal Protective Equipment

PPE Re-quired	Level/Gas Concentration	
	Level 1 ≥30 % and ≤ 60% LEL (1.5 and 3% gas)	Level 2 >60% LEL(>3% gas)
Single Layer FR Coveralls	Bulwark: CMD8 OR Silver Needle: 3017J1-A US HIVIS YEL	Bulwark: CMD8 OR Silver Needle: 3017J1-A US HIVIS YEL
Head Sock/ Hood	Chicago Protective Apparel – KCF-51	Chicago Protective Apparel – KCF-51
Insulated FR Hood		Silver Needle – #279L-4
Goggles	Paulson A-TAC Firefighters Goggle, 510-SLN OR Paulson A-TAC Firefighters Goggle, 510-SL	
Lens Cover	OPTIONAL: Paulson A-TAC Firefighters Goggle Clear Cover Lens, A-GLCC	
Work Gloves	Leather or Kevlar	
Insulated FR Coveralls		Silver Needle #3015Q – 3
Safety Har-ness		Built into Insulated Coveralls
Insulated Gloves		Silver Needle 372-16 Kevlar Glove
Lifeline		Technora Egress Personal Escape Rope
Supplied Air Respirator		MSA PremAire or Premaire Cadet Escape

5.0 Tools & Equipment SharePoint Site

5.1 Approved PPE products are maintained in Gas Standards and Procedures SharePoint Site.

5.1.1 PPE specification and vendor information for each item are shown on the Share-Point Site: <https://ameren.sharepoint.com/sites/GasIL/Materials/>.

5.2 PPE items that are currently in use, that meet the specifications in this section, and continue to function as designed may continue to be used until such time they are replaced.

UNCONTROLLED IF PRINTED

6.0 PPE Specifications

6.1 Level 1 PPE specifications

6.1.1 Level 1 Flash Suit (Single Layer, Flame Resistant (FR) Coveralls):

1. Designed and tested to protect wearer from the intense heat associated with a flash fire of very-short duration where the gas is consumed quickly.
2. FR material with minimum 5 calorie per square centimeter (cal/cm²) rating.
3. Velcro closure tabs at wrists and ankles.
4. FR reflective trim.
 - 4 a. For work on or near roads or in areas with moving equipment:
 - An AIC FR high-vis vest shall be worn over the older blue flash suits since they do not meet ANSI Class 2 high-visibility requirements.
 - The new yellow flash suits meet the ANSI Class 3 high visibility requirements so FR high-vis vest are not required.

The yellow flash suits can be worn for nighttime flagging since they meet the ANSI Class 3 high visibility requirement.

5. FR AIC logo/name.
 6. No modifications or alterations shall be made to the coveralls.
- #### 6.1.2 Level 1 Head Sock:
1. FR material with minimum 20 cal/cm² rating.
 2. Shall meet NFPA 1971 Standard for Structural Firefighting (NFPA 1971).

6.1.3 Goggles:

1. Shall meet both ANSI Z87.1 Eye Protection and NFPA 1971.

6.2 Level 2 PPE specifications

6.2.1 Level 2 insulated FR coveralls:

1. Insulated FR material with minimum 47 cal/cm² rating.
2. No FR reflective trim required.
3. No FR AIC logo/name required.

FR high-vis vests are not to be worn over Level 2 Insulated Coveralls.

6.2.2 Level 2 insulated FR hood:

1. Insulated FR material with minimum 47 cal/cm² rating.

6.2.3 Level 2 insulated gloves:

UNCONTROLLED IF PRINTED

1. Emergency Gas classification

OR

2. Structural Fire Fighting Glove meeting NFPA 1971.

6.2.4 Supplied air equipment:

1. All use of supplied air equipment shall comply with the Ameren Respirator Compliance Program which includes requirements for:

1 a. Medical qualification.

1 b. Respirator fit testing: shall be performed for the same brand, model, and size of face piece that will be worn in the field.

1 c. Training: field personnel shall be trained on the specific supplied air equipment provided by the company.

1 d. Care/cleaning.

1 e. Maintenance.

1 f. Inspections.

1 g. Breathing air quality: breathing air for supplied-air respirators shall meet OSHA Standard 29 CFR §1910.134, Grade D Compressed Breathing Air (Grade D) and shall be supplied from one of the following:

- Compressed air cylinders, certified by the vendor to be Grade D quality,
- Oil-free compressor designed specifically for breathing air use,

OR

- Work compressor:

- Breathing-air supply shall be connected before introduction of any anti-freeze or lubricating compounds.
- Compressor shall be equipped with a:
 - > Breathing-air filtration system to remove particulates, oils, water, and odor.
 - > Carbon monoxide alarm set to alarm at 10 ppm and shall be calibrated at least monthly.

2. The air supply shall be connected to the breathing air hoses via a regulator, gauge, and manifold system designed for breathing air

2 a. Gauges shall indicate both air supply and distribution pressures.

3. Breathing airline hoses (between the supply manifold and the user) shall be of the same manufacturer as the supplied-air unit and shall not exceed 300-feet in length.

3 a. An aluminized Zetex airline cover shall envelop the air supply line connected to the user as a means of protecting the airline hose from potential damage if a fire erupts.

4. Airline respirator units shall:

4 a. Be certified by National Institute for Occupational Safety and Health

UNCONTROLLED IF PRINTED

4 b. Include a minimum 5-minute escape bottle and a full facepiece.

6.2.5 Full body harness.

6.2.6 Lifeline:

1. Flame-resistant material with minimum 4,000-pound strength.

6.2.7 Airline cover:

1. Aluminized Zetex material, 2" inside diameter and minimum 15-foot length.

7.0 Level 1 PPE Availability, Care, and Storage

7.1 Availability

7.1.1 Single layer FR coveralls, head socks and goggles shall be assigned to all gas field personnel responding to gas emergencies.

7.2 Care and storage

7.2.1 PPE listed in [Paragraph 7.1.1](#) shall be carried on work trucks to be available when gas field personnel are working near or with escaping gas.

7.2.2 When not in use, PPE listed in [Paragraph 7.1.1](#) shall be protected and stored in bags such as Estex, Silver Needle, or equivalent to prevent soiling or damage.

Estex and Silver Needle bags are shown on the Tools & Equipment list on the Gas Standards and Procedures SharePoint site. See [Section 5.0](#).

7.2.3 FR coveralls shall be laundered in accordance with the manufacturer's instructions.

7.2.4 FR coveralls and head socks shall not be worn for everyday use.

8.0 Level 2 PPE Availability, Care, and Storage

8.1 Availability

8.1.1 The following PPE shall be assigned to Gas Supervisors:

1. Insulated FR coveralls.
2. Insulated FR hood.
3. Supplied air equipment.
4. Safety harness.
5. Lifeline.
6. Insulated gloves.

8.1.2 The Gas Supervisors shall ensure that the PPE listed in [Paragraph 8.1.1](#) is readily available and in good condition when needed.

8.2 Care and storage

8.2.1 When not in use, the PPE listed in [Paragraph 8.1.1](#) shall be protected and stored in a waterproof container or in an enclosed safety trailer.

- 8.2.2 Insulated FR coveralls and insulated FR hood shall not be compacted when stored.

Compaction greatly reduces the thermal protection of the material.

- 8.2.3 Supplied air equipment shall be stored in a manner that does not deform the face mask or kink the air lines.
- 8.2.4 Insulated FR coveralls and insulated FR hoods shall be laundered as necessary following the laundering instructions on the apparel label.

9.0 Inspection

- 9.1 All supplied-air equipment shall be inspected prior to use, at least monthly, and documented in Maximo. The equipment includes:
- 9.1.1 Air supply.
 - 9.1.2 Filtration system.
 - 9.1.3 Carbon monoxide alarm.
 - 9.1.4 Regulator/manifold system.
 - 9.1.5 Hoses.
 - 9.1.6 Airlines.
- 9.2 A qualified person shall inspect escape bottles annually and hydrostatically test them every 5 years.

End of Instructions.

Operator Qualification (OQ) Required?

NO.

Appendices

NONE.

Attachments

NONE.

Compliance Requirements

ANSI/ISEA 107 American National Standard for High-Visibility Safety Apparel and Accessories: ANSI Class 2

ANSI Z87.1 Eye Protection

NFPA 1971 Standard for Structural Firefighting

29 CFR §1910.132 Occupational Safety and Health Standards - Personal Protective Equipment

29 CFR §1910.134 OSHA Standard - Grade D Compressed Breathing Air

42 CFR §84.149 NIOSH - Type C supplied-air respirator, demand and pressure demand class; minimum requirements

UNCONTROLLED IF PRINTED

Reference Documents

[LEAK 2.1 Leak Management: Indoor Investigations](#)

Document Rescission

WIGE 2.2 Working In Gaseous Environment: Personal Protective Equipment, April 1, 2021

Revision Notes

Location of Changes	Summary of Changes
4.0 General – Table 1	Copied the approved PPE Table from the Gas Standards & Procedures SharePoint site. Approved PPE table was updated 7/06/21.

Working in a Gaseous Environment
WIGE 3 Forms and Reference Materials

April 1, 2023

Reference Materials

1. [RKI GX-3R Manual](#)

Document Rescission

None

Revision Notes

Location of Changes	Summary of Changes
New Section	Added the RKI-GX-3R personal air monitor

Gas Storage

GAS STORAGE

April 1, 2023

Gas Storage Table of Contents

Document	Title	Date
	Change Summary	May 15, 2022
SESD - Emergency Shutdown Systems		
SESD 0	Table of Contents	October 1, 2019
SESD 1	Requirements	January 1, 2014
SESD 2.01	Testing and Recording Procedures	October 1, 2019
SFCS - Compressor Stations		
SFCS 0	Table of Contents	July 1, 2014
SFCS 1	Operating Requirements	April 1, 2021
SFFD - Fire Detection Systems		
SFFD 0	Table of Contents	October 1, 2019
SFFD 1	Requirements	January 1, 2014
SFFD 2.01	Testing and Recording Procedures	October 1, 2019
SFGD - Gas Detection Systems		
SFGD 0	Table of Contents	October 1, 2019
SFGD 1	Requirements	January 1, 2014
SFGD 2.01	Testing and Recording Procedures	October 1, 2019

UNCONTROLLED IF PRINTED

GSIC - Gas Storage Internal Corrosion Monitoring

<u>GSIC 0</u>	Table of Contents	January 1, 2013
<u>GSIC 1.01</u>	Internal Corrosion Monitoring Plan	January 1, 2013
<u>GSIC 1.02</u>	Safety Considerations	January 1, 2013
<u>GSIC 2.01</u>	Internal Corrosion Monitoring	January 1, 2013
<u>GSIC 2.02</u>	Monitoring Corrosion Weight Loss Coupons	January 1, 2013
<u>GSIC 2.03</u>	Collecting and Testing of Fluid Samples	January 1, 2013
<u>GSIC 2.04</u>	Sampling Natural Gas for Laboratory Analysis	January 1, 2013
<u>GSIC 2.05</u>	Field Testing Natural Gas for Hydrogen Sulfide	January 1, 2013
<u>GSIC 2.06</u>	Field Testing for Bacteria (MIC)	January 1, 2013
<u>GSIC 2.07</u>	Electric Resistance (ER) Corrosion Probe	January 1, 2013
<u>GSIC 2.08</u>	Linear Polarization Resistance (LPR) Probe	January 1, 2013
<u>GSIC 2.09</u>	Field Testing Natural Gas for Oxygen	January 1, 2013
<u>GSIC 2.10</u>	Coupon/Probe Retraction Operation	January 1, 2013
<u>GSIC 4</u>	Forms and Reference Materials	January 1, 2016

SECT 6 - Design, Construction Storage Wells

<u>SECT 6.0</u>	Table of Contents	October 15, 2018
<u>SECT 6.2</u>	Wellhead Equipment and Valves	October 15, 2018
<u>SECT 6.3</u>	Well Casing	April 1, 2021
<u>SECT 6.4</u>	Casing Cementing Practices	October 15, 2018
<u>SECT 6.5</u>	Completion and Stimulation	October 15, 2018
<u>SECT 6.7</u>	Well Closure (Plugging and Abandonment)	April 1, 2021
<u>SECT 6.8</u>	Environmental, Safety and Health	October 15, 2018

<u>SECT 6.9</u>	Testing and Commissioning	October 15, 2018
<u>SECT 6.10</u>	Monitoring of Construction Activities	October 15, 2018
<u>SECT 6.11</u>	Recordkeeping	October 15, 2018
<u>SECT 6.20</u>	Forms and Reference Materials - REMOVED	April 1, 2021

SECT 7 - Attainment of Maximum Reservoir Pressure and Total Capacity

<u>SECT 7.0</u>	Table of Contents	October 15, 2018
<u>SECT 7.2</u>	Testing and Commissioning	October 15, 2018
<u>SECT 7.3</u>	Reservoir Integrity Monitoring	October 15, 2018
<u>SECT 7.5</u>	Recordkeeping	October 15, 2018

SECT 8 - Risk Management for Storage Operations

<u>SECT 8.0</u>	Table of Contents	October 15, 2018
<u>SECT 8.2</u>	Risk Management	October 15, 2018
<u>SECT 8.3</u>	Data Collection and Integration	October 15, 2018
<u>SECT 8.4</u>	Threat and Hazard Identification and Analysis	October 15, 2018
<u>SECT 8.5</u>	Risk Assessment	October 15, 2018
<u>SECT 8.7</u>	Periodic Review and Reassessment	October 15, 2018
<u>SECT 8.7.4</u>	Risk Assessment Procedures	October 1, 2019
<u>SECT 8.8</u>	Recordkeeping	October 15, 2018
<u>SECT 8.20</u>	Forms and Reference Materials	October 1, 2019

SECT 9 - Integrity Demonstration, Verification and Monitoring Practices

<u>SECT 9.0</u>	Table of Contents	October 15, 2018
---------------------------------	-------------------	------------------

<u>SECT 9.2</u>	Overview	October 15, 2018
<u>SECT 9.3.1</u>	Well Integrity Evaluation	October 15, 2018
<u>SECT 9.3.2</u>	Well integrity Monitoring	April 1, 2020
<u>SECT 9.8</u>	Recordkeeping	October 1, 2019
<u>SECT 9.20</u>	Forms and Reference Materials - REMOVED	April 1, 2021

SECT 10 - Site Security, Safety, Inspections and Emergency Preparedness and Response

<u>SECT 10.0</u>	Table of Contents	October 1, 2019
<u>SECT 10.2</u>	Site Security and Safety	October 1, 2021
<u>SECT 10.4</u>	Signage	October 15, 2018
<u>SECT 10.6</u>	Emergency Preparedness and Response	April 1, 2021
<u>SECT 10.6.3</u>	Blowout Contingency Plan	October 15, 2018

SECT 11 - Procedures and Training

<u>SECT 11.0</u>	Table of Contents	October 15, 2018
<u>SECT 11.2.1</u>	Construction, Operations and Maintenance Procedures	October 15, 2018
<u>SECT 11.4</u>	Emergency Plans	October 15, 2018
<u>SECT 11.7</u>	Interaction with Gas Control Room	October 15, 2018
<u>SECT 11.9</u>	Safety and Environmental Programs	October 15, 2018
<u>SECT 11.11</u>	Management of Change	October 15, 2018
<u>SECT 11.13</u>	Records	October 15, 2018
<u>SECT 11.20</u>	Forms and Reference Materials - REMOVED	April 1, 2021

Supersedes: April 1, 2020

SESD - Emergency ShutDown

EMERGENCY SHUTDOWN SYSTEMS

October 1, 2019

SESD 0 - Table of Contents

Requirements

[SESD 1](#)

1. Objective
2. Specific Emergency Requirements
3. Design Changes

Procedures

Test and Recording Procedures

[SESD 2.01](#)

1. General
2. Testing Procedures
3. Recording Procedures

Supersedes: January 1, 2014

January 1, 2014

EMERGENCY SHUTDOWN SYSTEMS

SESD 1 - Requirements

1. Objective

- A. This section outlines the requirements for emergency shutdown systems for field compressor stations, except for unattended field compressor stations of 1,000 horsepower (746 kilowatts) or less.
- B. Required testing procedures, appropriate documentation of testing results and record keeping is discussed.

2. Specific Emergency System Requirements

An emergency shutdown system must include the following:

- A. It must be able to block gas out of the station and blow down the system piping.
- B. It must discharge gas from the blow down piping at a location where gas will not create a hazard.
- C. It must provide means for the shutdown of gas compressing equipment, gas fires and electrical facilities in the vicinity of gas headers and in the compressor building, EXCEPT that: electrical circuits supplying emergency lighting required to assist station personnel in evacuating the compressor building and the area in the vicinity of the gas headers MUST remain energized; electrical circuits needed to protect equipment from damage MAY remain energized
- D. It must be operable from at least two locations, EACH of which is outside the gas area of the station; near the exit gates, if the station is fenced, or near emergency exits, if not fenced; and, no more than five hundred (500) feet (153 meters) from the limits of the station
- E. If a compressor station supplies gas directly to a distribution system with no other source of gas available, the emergency shutdown system MUST be designed so that it will not function at the wrong time and cause an unintended outage on the distribution system.

3. Design Changes

Engineering design for revisions to existing or new gas compressor station emergency shutdown systems shall include, but not be limited to:

- A. Compressor suction and discharge valves shall include pneumatic or electric devices that, when activated by the ESD system, will eliminate any gas at the input/output to each compressor.
- B. Emergency shutdown system design shall include adequate relief capacity for cylinder and piping capacity to vent when activated.
- C. All engineering design proposals for gas compressor stations shall include an emergency shutdown system schematic for the station files.
- D. The Gas Storage Engineer - Facilities must review and approve engineering design for compressor station emergency shutdown systems.

Supersedes: January 1, 2013

UNCONTROLLED IF PRINTED

October 1, 2019

EMERGENCY SHUTDOWN SYSTEMS

SESD 2.01 - Testing and Recording

1. General

- A. The Emergency Shutdown (ESD) system at each compressor station shall be tested once each calendar year, at intervals not to exceed 15 months.
- B. The ESD system shall be tested by tripping one of the hard wired shut down systems or one of the hand pull stations that result in block-in isolation valves closing and ESD vent valves opening.
- C. Actual block-in valve operation and vent valve operation, to prove system capability, is required only once for each annual test.
- D. ESD vent valve operability shall be tested with normal operating pressure at the ESD vent valve(s). ESD vent valve downstream isolation valve(s) (if available) may be closed during the ESD testing to prevent station blow down as long as the ESD vent valve(s) are still subjected to normal operating pressure during testing.

2. Testing Procedures

- A. An Operator Qualified Storage Field employee shall test all alarm inputs that trigger the ESD system to ensure that they are functioning properly and are supplying the required outputs to initiate the block-in or block-in and vent actions.
- B. The manual pull/valve stations of the ESD system shall also be tested to verify that they are functioning properly.

3. Recording Procedures

- A. It shall be the Operator Qualified Storage Field employee's responsibility to ensure that the ESD system test is recorded in Maximo.

Supersedes: July 1, 2014

EMERGENCY SHUTDOWN SYSTEMS
SESD 4 - Forms and Reference Materials

October 1, 2019

This section has been removed. The form is now electronic.

Supersedes: January 1, 2016

UNCONTROLLED IF PRINTED

SFCS - Compressor Stations

| July 1, 2014

COMPRESSOR STATIONS

SFCS 0 -Table of Contents

Procedures

Operating Requirements

[SFCS 1](#)

1. Objective
2. Safety and Security
3. Storage of Combustible or Flammable Materials
4. Ventilation
5. Liquid Removal
6. Startup, Shutdown, Operating

COMPRESSOR STATIONS
SFCS 1 - Operating Requirements

May 15, 2022

1. Objective

- A. This section addresses the various operating requirements for a compressor station(s) located at the Ameren Illinois gas storage fields.
- B. The set-up, lay-out and equipment utilized at the storage fields vary by location and the legacy company that designed and developed the field.
- C. Procedures contained in this section will be general in nature with the more specific procedures located at the individual compressor stations.

2. Safety and Security

- A. Each compressor station has adequate fire protection facilities. If fire pumps are to be utilized the emergency shutdown system will not affect utilization of the pump(s).
- B. Each compressor station prime mover has an automatic device that shuts down the unit before the speed of either the prime mover or the driven unit exceeds a maximum safe speed. This does not include electrical induction or synchronous motors.
- C. Each compressor unit has a shutdown or alarm device that operates in the event of inadequate cooling or lubrication of the unit.
- D. Each compressor station gas engine that operates with pressure gas injection is equipped to automatically shut off the fuel supply and vent the distribution manifold.
- E. Muffler(s) of the gas engine in a compressor station will have slots or holes in the baffles of each compartment that prevents gas from being trapped in the muffler.
- F. Each compressor station has fire and gas detection and alarm systems. See [SFFD](#) and [SFGD](#).
- G. Each compressor station has an emergency shutdown system. See [SESD](#).
- H. Each compressor station is located within a fenced area must have at least 2 gates located so as to provide a convenient opportunity for escape to a place of safety or have other facilities affording a similarly convenient exit from the area. Each gate located within 200 feet of any compressor plant building must open outward and, when occupied, must be openable from the inside without a key.
- I. Electrical facilities installed in compressor stations, conforms to the National Electrical Code, ANSI/NFPA 70, where applicable.

3. Storage of Combustible or Flammable Materials

- A. Combustible or flammable materials in quantities beyond those required for everyday use, or other than those normally used in the compressor station buildings, are stored at least twenty five (25) feet or further away from the compressor building.
- B. Combustible or flammable material located at the storage fields normally consist of diesel fuel, gasoline, methanol and mercaptan. Quantities of these material stored at each field varies.
- C. Some of the storage fields have above grade storage tanks that are located twenty five (25) feet or more from the compressor station and more than ten (10) feet from the storage field property line.

UNCONTROLLED IF PRINTED

D. Combustible and flammable materials are in durable containers suitable for the material being stored

Storage and protection of combustible or flammable materials meet the requirements of NF-PA 30, Flammable and Combustible Liquids Code.

4. Ventilation

A. Each compressor station building must be ventilated to ensure that employees are not endangered by accumulation of gas in rooms. Sumps, attics, pits, or other enclosed places.

B. The compressor station building incorporates convection or electrical powered ventilation and/or a gas detection sensor system.

C. The convection or electric powered ventilation system design recommendation considers gas quality, floor to ceiling temperature differential and natural air ventilator size and installation location to ensure building environment remains below the lower explosive limit (LEL) of natural gas, 5.0% gas-in-air.

D. Gas detector systems shall be designed to remain energized with a power loss and may systematically open power ventilation, or automatically shut down compressors and/or signal an alarm. See [SFGD](#) for gas detection systems and testing.

E. Ventilation requirements are not applicable to compressor stations that are not enclosed within a building since there is free circulation of air around the station.

5. Liquid Removal

A. Where entrained vapors in gas may liquefy under the anticipated pressure and temperature conditions, the compressor must be protected against the introduction of those liquids in quantities that could cause damage.

B. Each liquid separator used to remove entrained liquids at a compressor station must have a manually operable means of removing these liquids.

C. Where slugs of liquid could be carried into the compressor, have either automatic liquid removal facilities, an automatic compressor shutdown device or a high liquid level alarm.

D. Separators will be manufactured in accordance with section VIII of the ASME Boiler and Pressure Vessel Code, except that liquid separator(s) constructed of pipe and fittings without internal welding must be fabricated with a design factor of 0.4 or less.

6. Startup, Shutdown, Operating

A. Since the compressor station equipment utilized in the Ameren Illinois Gas Storage Fields varies from field to field, each storage field has its own specific startup and shutdown procedures.

B. Operating procedures for each field also varies depending on the equipment and layout of the field. Specific operating procedures are located at each field.

Supersedes: October 1, 2021

SFFD - Fire Detection System

FIRE DETECTION SYSTEMS

October 1, 2019

SFFD 0 - Table of Contents

Requirements

[SFFD 1](#)

1. Objective

2. Requirements

Procedures

Test and Recording

[SFFD 2.01](#)

1. Pre-Testing Cautions

2. Fire Detection and Initiating Device Testing Procedures

3. Fire Detection Alarm and ESD Actuation Testing Procedures

4. Reporting and Verification and Record Retention

Supersedes: January 1, 2014

FIRE DETECTION SYSTEMS

January 1, 2014

SFFD 1 - Requirements

1. Objective

This section outlines the requirements for testing the fire detection and alarm systems in compressor stations

2. Requirements

A. The fire detectors and other initiating devices in the fire system shall be tested twice per calendar year at intervals not to exceed seven and a half (7 1/2) months.

B. The Fire System Trouble alarm will be tested twice per calendar year at intervals not to exceed seven and a half (7 1/2) months

C. The fire detection gas control alarms and ESD actuation shall be tested once each calendar year at intervals not to exceed fifteen (15) months.

Supersedes: January 1, 2013

FIRE DETECTION SYSTEMS
SFFD 2.01 - Testing and Recording

October 1, 2019

1. Pre-Testing Cautions

A. On-site personnel should be notified prior to testing Fire Detection system to prevent unwarranted concern or reaction to alarms occurring during the test period.

B. **Caution:** The fire detection and alarm system is connected to the plant emergency shutdown system and sends a trouble alarm to Gas Control. Isolate equipment from the alarm circuit during the test. Isolated devices shall be reconnected at the completion of test activities.

2. Fire Detector and Initiating Device Testing Procedures

A. The following checks shall be completed two times per calendar year, maximum interval of 7-1/2 months and shall be recorded by an Operator Qualified Storage Field employee.

B. Verify proper operation of the Fire System Trouble alarm to Gas Control (if applicable).

C. Activate each detector and alarm initiating device. Check that the proper alarm and zone indications are given at the fire control panel.

3. Fire Detection Alarm and ESD Actuation Testing Procedures

A. The following checks shall be completed at least one time per calendar year, maximum interval of 15 months and shall be reported by an Operator Qualified Storage Field employee.

(1) Verify proper operation of the Fire Alarm signal(s) to Gas Control

(2) Verify proper operation of the Fire Alarm inputs to the ESD system

4. Reporting and Verification and Record Retention Instructions

A. It shall be the Operator Qualified Storage Field employee responsibility to ensure that the Fire Detection Alarm Inspection is recorded in Maximo.

Supersedes: January 1, 2014

FIRE DETECTION SYSTEMS
SFFD 4 - Forms and Reference Materials

October 1, 2019

This section has been removed. The form is now electronic.

Supersedes: January 1, 2016

UNCONTROLLED IF PRINTED

SFGD - Gas Detection System

GAS DETECTION SYSTEMS

October 1, 2019

SFGD 0 - Table of Contents

Requirements

[SFGD 1](#)

1. Objective

2. Requirements

Procedures

Test and Recording

[SFGD 2.01](#)

1. Pre-Testing Cautions

2. Gas Detector Calibration Quarterly Testing Procedures

3. Gas Detection System Alarm Testing Procedures

4. Reporting and Record Retention Instructions

Supersedes: January 1, 2014

GAS DETECTION SYSTEMS
SFGD 1 - Requirements

January 1, 2014

1. Objective

This section outlines the requirements for the installation of fixed gas detection and alarm systems in compressor stations, the level of monitoring necessary and the maintenance and performance testing requirements.

2. Requirements

A. Not later than September 16, 1996, each compressor building in a compressor station must have a fixed gas detection and alarm system installed, unless the building is constructed so that at least fifty (50) percent of its upright side area is permanently open, or it is located in an unattended field compressor station of 1,000 horsepower (746kW) or less.

B. Except when shutdown of the system is necessary for maintenance, the system must be able to continuously monitor the compressor building for a concentration of gas-in-air of not more than 25% LEL and warn persons about to enter the building and people in the building of the danger should this condition be exceeded.

C. Each gas detection and alarm system must be maintained to function properly. Any maintenance required must include performance tests.

Supersedes: January 1, 2013

GAS DETECTION SYSTEMS
SFGD 2.01 - Testing and Recording

October 1, 2019

1. Pre-Testing Cautions

A. On-site personnel should be notified prior to testing the Gas Detection systems to prevent unwarranted concern or reaction to alarms occurring during the test period.

B. **Caution: The gas detection and alarm system is connected to the plant emergency shut-down system and sends a trouble alarm to Gas Control. Isolate equipment from the alarm circuit during the test. Isolated devices shall be reconnected at the completion of test activities.**

2. Gas Detector Calibration Quarterly Testing Procedure

A. Routine performance tests (calibration checks) of the gas sensors and control modules shall be completed four times each calendar year, not to exceed each calendar quarter by more than forty five (45) days and shall be recorded by an Operator Qualified Storage Field employee .

B. Verify proper operation of the Gas Trouble alarm signal to Gas Control (if applicable).

C. Perform a calibration check of each gas sensor. Calibrate each Gas Sensor and/or Control Module that does not provide indication with test gas applied.

3. Gas Detection System Alarm Testing Procedure

A. The following checks shall be completed at least one time per calendar year, maximum interval of 15 months and shall be recorded by an Operator Qualified Storage Field employee.

(1) Check mounting positions of all gas sensor assemblies and verify that modifications to plant layout did not impact their effectiveness.

(2) Verify proper operation of the Gas Alarm signal(s) to Gas Control.

(3) Verify proper operation of all ESD inputs and other activated devices from the Gas Detection System.

4. Reporting and Verification and Record Retention Instructions

A. It shall be the Operator Qualified Storage Field employee responsibility to ensure that the Gas Detection Alarm Inspection is recorded in Maximo

Supersedes: July 1, 2014

GAS DETECTION SYSTEMS
SFGD 4 - Forms and Reference Materials

October 1, 2019

This section has been removed. The form is now electronic.

Supersedes: January 1, 2016

UNCONTROLLED IF PRINTED

GSIC - Storage Internal Corrosion

GAS STORAGE INTERNAL CORROSION MONITORING GSIC 0 Table of Contents

January 1, 2013

Requirements

Internal Corrosion Monitoring Plan

[GSIC 1.01](#)

1. Objective
2. Part 192 References
3. Related Procedures and Forms
4. Operational Data and Physical Data
5. Operational Data
6. Physical Data
7. Gas Samples
8. Gas Unit Conversions
9. Liquid Samples
10. Additional Tests (Optional)
11. Laboratory Tests
12. Analysis of Sludge or Solid Samples
13. Corrosion Monitoring
14. Corrosion Rate and Remaining Life
15. Examination of Exposed Surfaces
16. Root Cause Analysis
17. Data Trending
18. New or Revised Piping
19. Documentation
20. Data for Audits and Reviews

Safety Considerations

[GSIC 1.02](#)

1. Objective
2. Part 192 References
3. Safety Considerations
4. Documentation

Procedures

Internal Corrosion Monitoring

[GSIC 2.01](#)

1. General
2. Part 192 References

UNCONTROLLED IF PRINTED

3. Safety Considerations
4. Site Considerations
5. Ultrasonic Thickness Testing
6. Visual Examination
7. Sampling and Testing - Liquids
8. Sampling and Testing - Solids
9. Sample Preservation
10. Examination of Cut-Out Pipe Segment
11. Documentation

Monitoring Corrosion Weight Loss Coupons

[GSIC 2.02](#)

1. General
2. Part 192 References
3. Safety Considerations
4. Coupon Preparation
5. Vessel Preparation
6. Coupon Removal
7. Coupon Installation
8. Submit to Laboratory
9. Documentation

Collecting and Testing of Fluid Samples

[GSIC 2.03](#)

1. General
2. Part 192 References
3. Safety Considerations
4. Sample Equipment Description
5. Annual Liquid Sampling Location Selection
6. Testing Process
7. Documentation

Sampling Natural Gas for Laboratory Analysis

[GSIC 2.04](#)

1. General
2. Part 192 References
3. Safety Considerations
4. Field Tests
5. Cylinder Preparation & Transport
6. Sampling Guidelines
7. Purging - Fill and Empty Method

8. Laboratory Analysis
9. On-Site Chromatographs
10. Documentation

Field Testing Natural Gas for Hydrogen Sulfide

[GSIC 2.05](#)

1. General
2. Part 192 References
3. Safety Considerations
4. Test Setup
5. Sample Equipment Preparation
6. Testing Process
7. Documentation

Field Testing for Bacteria (MIC)

[GSIC 2.06](#)

1. General
2. Part 192 References
3. Safety Considerations
4. Bacteria Culture Vial Preparation
5. Testing Guidelines
6. Field Testing Process
7. Serial Dilution
8. Incubation and Results
9. Documentation

Electric Resistance (ER) Corrosion Probe

[GSIC 2.07](#)

1. General
2. Part 192 References
3. Safety Considerations
4. Collecting ER Probe Data
5. Calculation of Corrosion Rate
6. Documentation

Linear Polarization Resistance (LPR) Probe

[GSIC 2.08](#)

1. General
2. Part 192 References
3. Safety Considerations
4. Collecting LPR Probe Data
5. Documentation

Field Testing Natural Gas for Oxygen

[GSIC 2.09](#)

1. General
2. Part 192 References
3. Safety Considerations
4. Analyzer Precautions
5. Collecting Oxygen Measurements
6. Documentation

Coupon/Probe Retraction Operation

[GSIC 2.10](#)

1. General
2. Part 192 References
3. Tool Selection
4. Safety Considerations
5. Preparation
6. Insertion/Retraction of Device
7. Documentation

Forms and Reference Materials

[GSIC 4](#)

Forms

1. GSIC - 2.01-1 Storage - Internal Exam Form
2. GSIC - 2.02-1 Weight-Loss Coupon Monitoring Report
3. GSIC - 2.03-1 Annual Field Liquid Sampling
4. GSIC - 2.04-1 Field Gas Sampling
5. GSIC - 2.05-1 Annual on-Site H₂S Readings
6. GSIC - 2.06-1 Field Analysis for MIC
7. GSIC - 2.10-1 Insertion/Retraction Safety Check List

Reference Materials

- 2.02-01. Weight-Loss Coupon & Coupon Holder
- 2.02-02. Accurate Tool Insertion & Retraction Instructions for Hand Insertion Tools
- 2.02-03. The Accurate Retractable Corrosion Coupon Holder
- 2.02-04. Coupon Holders
- 2.02-05. Metal Samples Insulators, Washers & Spacers
- 2.02-06. Model RT4000 Coupon Insertion System_ Retractable with Packing Gland
- 2.04-01. MSA H₂S - 100 Detector Tube
- 2.04-02. MSA H₂S - 1 Detector Tube
- 2.04-03. Cole Parmer Tygon SE-200 Tubing and Fittings
- 2.04-04. MSA Kwik-Draw Sample Pump Specification
- 2.07-01. Model ER4100 Series Electrical Resistance Probe

UNCONTROLLED IF PRINTED

- 2.07-02. Model MS1500E Data Logger (intrinsically safe)
- 2.08-01. Model LP1100 & LP4100 Linear Polarization Resistance Probe
- 2.08-02. Model MS3500L & 3510L Remote LPR Data Logger
- 2.09-01. Model 1000RS Portable Trace Oxygen Analyzer Manual
- 2.10-01. AMI Guardian Regulator & Liquid Separator
- 2.10-02. Metal Samples Safety Chain Factory Installation
- 2.10-03. Metal Samples SR2159 Easytool Operating & Maintenance Manual
- 2.10-04. Metal Samples Length Calc. and Accessories for Retractable System
- 2.10-05. Metal Samples Packing Gland Instructions
- 2.10-06. Metal Samples SR2159 Retractor Video
- 2.10-07. Accurate Tools Insertion & Retraction Systems Instructions
- 2.10-08. Accurate Tools Retractable Systems Catalog
- 01 WT Balls Brochure
- 02 JACAM WT Balls

GAS STORAGE INTERNAL CORROSION MONITORING
GSIC 1.01 Internal Corrosion Monitoring Plan

April 1, 2023

1. Objective

- A. This section describes the guidelines for monitoring metallic piping systems and related appurtenances, such as vessels, for the precursors to and effects of internal corrosion.
- B. The processes and procedures contained in this section are applicable only to storage field gathering system piping carrying dry gas, wet gas or both.
- C. Internal corrosion control for pipelines outside of the storage fields is covered in [CORR 1](#). Ameren Illinois' (AIC) Operation and Maintenance (O&M) Plan.
- D. Potential corrosivity may be estimated by knowing the chemical composition of the gas transported, liquids removed, or sludge and solids found in the pipeline. Samples of these constituents are taken periodically from sampling points and at other times whenever the opportunity exists.
- E. Internal surfaces of pipe exposed for any reason are inspected for internal corrosion damage and tested when conditions for internal corrosion are observed. See [CORR 1 Appendix A](#) - Buried Pipe Examination Form. Samples can be tested in the field as described in the following subsections and/or submitted for laboratory analysis at the discretion of the Corrosion Control personnel.
- F. Test result interpretations must include knowledge of the history of the segment, the limitations of sampling and testing techniques, and the basic principles governing the process of internal corrosion. When necessary, additional investigation, testing, and results evaluation are performed to determine if an environment is more or less corrosive than indicated by the available data.

2. Part 192 Reference

49 CFR §§ 192.475, 192.476, & 192.477

3. Related Procedures and Forms

Section GSIC 2.01 - Internal Corrosion Examination

Section GSIC 2.02 - Monitoring Corrosion Weight Loss Coupons

Section GSIC 2.03 - Collecting and Testing of Fluid Samples

Section GSIC 2.04 - Sampling Natural Gas for Laboratory Analysis

Section GSIC 2.05 - Field Testing Natural Gas for Hydrogen Sulfide

Section GSIC 2.06 - Field Testing For Bacteria (MIC)

Section GSIC 2.07 - Electric Resistance (ER) Corrosion Probe

Section GSIC 2.08 - Linear Polarization (LPR) Corrosion Probe

Section GSIC 2.09 - Field Testing Natural Gas for Oxygen

Section GSIC 2.10 - Coupon / Probe Retractor Operation

Form GSIC - 2.01-1 Storage - Internal Exam Form

Form GSIC - 2.02-1 Weight-Loss Coupon Monitoring Report

UNCONTROLLED IF PRINTED

Form GSIC - 2.03-1 Annual Field Liquid Sampling

Form GSIC - 2.04-1 Field Gas Sampling

Form GSIC - 2.05-1 Annual On-Site H₂S Readings

Form GSIC - 2.06-1 Field Analysis for MIC

Form GSIC - 2.10-1 Insertion/Retraction Safety Check List

4. Operating Data and Physical Data

To form a complete picture of the potential for internal corrosion, certain operational data should be gathered and analyzed in conjunction with hands on examinations and test result data all of which are applied in the context of the physical make-up of the system.

5. Operational Data

The following data should be available from general records of field operation on a daily, weekly, or other interval basis. Individual data points may not be as useful as trends of the operating parameters. The information should be recorded at the time of sample collection from a measurement point as close as possible to the sample taking location. As with any good logging, the date and time of the readings should be recorded in order to correlate its value with the collection of samples for testing.

A. Pressure

(1) The operating pressure at the time of sampling is necessary for calculating the partial pressure of gas components accurately. It is also used for calculating the stress level in the pipe, which may be important if deteriorated pipe is discovered.

(2) Other pressures to be aware of include the maximum allowable operating pressure (MAOP) and design pressure of the portion of the system under review. These should be part of the permanent record of the system.

B. Temperature

This data point may provide information concerning corrosion rates. Increased temperature will generally result in increased corrosion growth rates, which in turn are used to determine remaining life calculations for the pipe.

C. Typical Flow Rates

This information can be used to determine surface velocities along the pipe wall which will describe the type of flow, especially in mixed phase systems. The type of corrosion suspected might then be predicted.

D. Liquid Volumes Removed

All volumes of liquid collected, whether or not tested either in field or laboratory, should be recorded for each location where liquid is drained. Just as important is noting when no liquid is present during a routine blow down activity. See [PCBH 3 Inspection Form](#).

E. Sludge or Solids Collected

All quantities of sludge or solids removed whether or not it is tested should be recorded and each location noted from where it is removed.

6. Physical Data

UNCONTROLLED IF PRINTED

Materials used, design and construction practices, history of the system or segment, etc. may have an effect on where internal corrosion occurs and what form it might take.

A. Age of pipe

Older pipe may have more inclusions that can serve as internal corrosion initiation sites. When new pipe is installed in older systems, more aggressive corrosion has occasionally been found to occur in the newer pipe.

B. Type of Seam versus Seamless

Certain ERW pipe seams are susceptible to selective seam corrosion at the fusion line and/or in the heat affected zone of the seam weld. The wall thickness of older seamless pipe may have a significant variance around its circumference that could affect presumptions made from wall thickness measurements.

C. Welding Procedures/Quality

For example, welds that exhibit poor workmanship may cause greater disruption to local flow or provide crevices at the inner diameter of the weld. These are places where internal corrosion can start.

D. Design and Construction

Low spots, unused bypasses, dead legs and similar locations are sites where liquids or contaminants will accumulate when present. Places where the flow drastically changes direction or velocity are susceptible. Couplings and flanges present both flow disruption and accumulation points.

E. Hydrostatic Test Records

(1) In addition to knowing when the pipeline was tested and to what pressure, such records may indicate how long the water was left in the pipeline before the dewatering process and the level of dryness achieved after dewatering.

(2) The source of the test water when available can be valuable. Surface water from lakes, ponds or rivers is more likely to contain organisms that could lead to the breeding of bacteria inside the pipeline.

F. Repairs and Replacements

(1) Repairs, especially due to internal corrosion, may lead to susceptible sections of the piping that require closer scrutiny.

(2) The location and dates will indicate where problems have historically been found and lead to determination of possible causes.

(3) Similar information about replacements, including the results of internal inspections at those locations, is equally valuable.

G. Original Water Composition

(1) If available, original water composition within the formation may be used to validate the amount of various constituents (i.e. iron, calcium, or sulfate) identified in a liquid/solid/sludge sample.

(2) For example, a solid sample was collected from a pig run identified a high concentration of iron. The original water composition shows a large amount of iron present suggesting that the majority of the iron is most likely from the ground water rather than corrosion from the pipe.

7. Gas Samples

A. Gas samples are taken during both the injection season and the withdrawal season. As gas chromatographs are installed and implemented, gas sampling may be supplemented or superseded by chromatograph data at the discretion of the Corrosion Control personnel.

B. In addition to samples, gas is tested on-site for Hydrogen Sulfide (H₂S) content.

C. Sample Locations & Methods

(1) Gas within the storage field is considered reasonably homogeneous however; some variation may be seen between wells. Therefore, additional testing at individual wells may be limited to specific gas components at the discretion of the Corrosion Control personnel and should be based upon historical gas analysis trends.

(2) During the injection season, station samples are collected at meter locations.

(3) During the withdrawal, station samples are collected at the station inlet of the gathering system.

(a) H₂S testing is performed on active injection/withdrawal wells in fields where the station H₂S is detected above 6 PPM.

(b) H₂S content is tested on-site at each active wellhead using stain tube gas detectors and/or a Sensit Gold CGI.

(4) Station gas samples first tested for H₂S and then collected in stainless steel cylinders for laboratory testing.

(a) Gas sampling and testing is performed in accordance with [GSIC 2.04](#) - Sampling Natural Gas For Laboratory Analysis, and documented on [Form GSIC-2.04-1, Field Gas Sampling](#).

(b) Alternatively, H₂S may be continuously monitored using electronic equipment.

(5) Field testing and/or sampling may not be required for components that are continuously monitored by gas chromatography. The need for additional testing will be determined by the Corrosion Control personnel.

D. Analysis for Internal Corrosion Indicators

For the purpose of monitoring for internal corrosion, the samples are analyzed for carbon dioxide (CO₂), hydrogen sulfide (H₂S), oxygen (O₂), and water vapor.

(1) CO₂ - Carbon Dioxide

(a) The percentage of CO₂ in the gas stream is determined through gas chromatography. Using the percentage CO₂ and gas pressure, the partial pressure of CO₂ can be determined. Refer to section [8- Gas Unit Conversions](#) below for unit conversions commonly used for gas analysis.

(b) For purposes of this test, the gas pressure at time of sampling as well as minimum and maximum pressure of the storage field is used. Figure 1 illustrates the concentration (%) at which the gas will exceed the CO₂ concern levels at either the minimum or maximum storage field pressure.

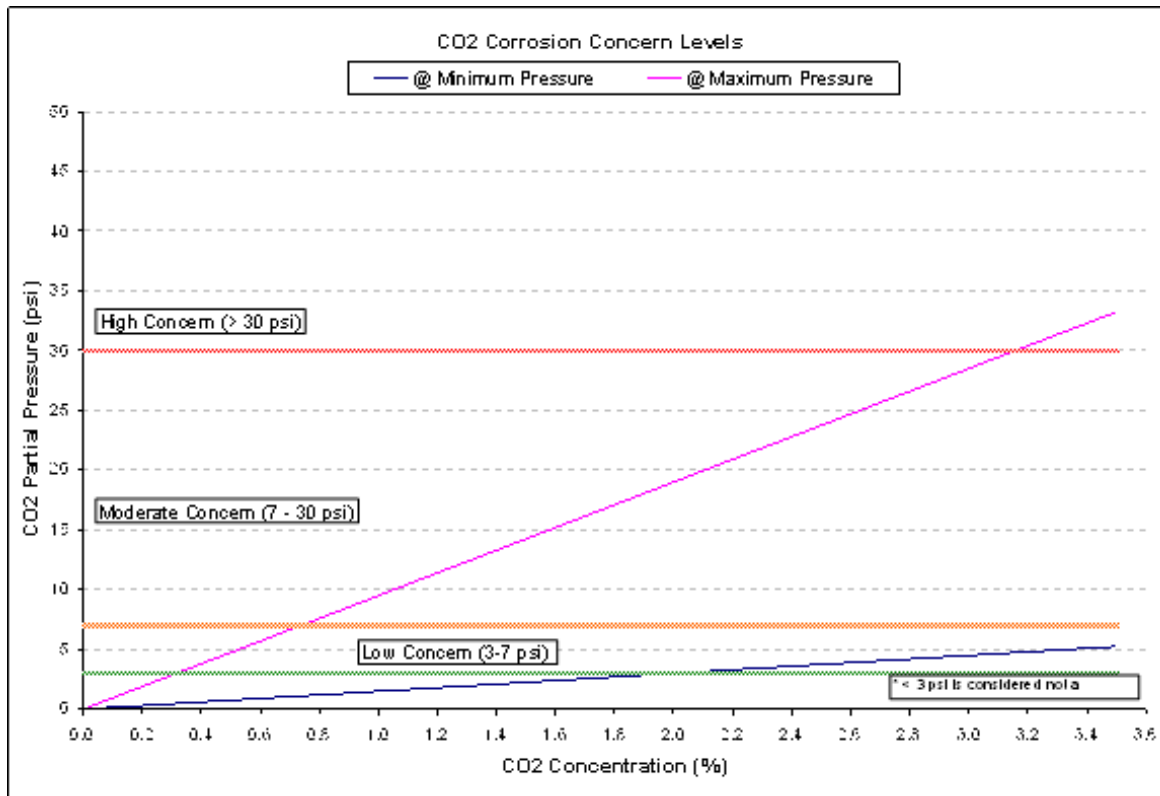

Figure 1. Example of CO₂ Corrosion Concern Levels

(c) As long as the partial pressure of CO₂ is below 3 psig, it is not a factor affecting internal corrosion of the piping.

(d) The table below identifies concern levels for CO₂ partial pressures stated in NACE RP0106-2006 "Control of Internal Corrosion in Steel Pipelines and Piping Systems." The partial pressure versus CO₂ concentration graph in Figure 1 can be used to identify when a carbon dioxide concern exists.

CO ₂ Partial Pressure (psig)	Level of Concern
< 3	Low Risk
3 - 30	Moderate Risk
> 30	High Risk

(2) H₂S - Hydrogen Sulfide

(a) The amount of H₂S in the gas stream is determined by using a stain tube or an electronic meter. The stain tube provides a read out in ppm. Electronic meters give a direct reading of the percent of H₂S in the gas.

(b) In terms of internal corrosion, H₂S is typically evaluated in ppm and / or partial pressure. Refer to section 8 - Gas Unit Conversions below for unit conversions commonly used for gas analysis.

(c) For purposes of this test, the gas pressure at time of sampling, as well as minimum and maximum pressure of the storage field, is used.

(d) Figure 2 illustrates at what concentration (ppm) the gas will exceed the H₂S concern level (0.05 psi) at a minimum or maximum pressure.

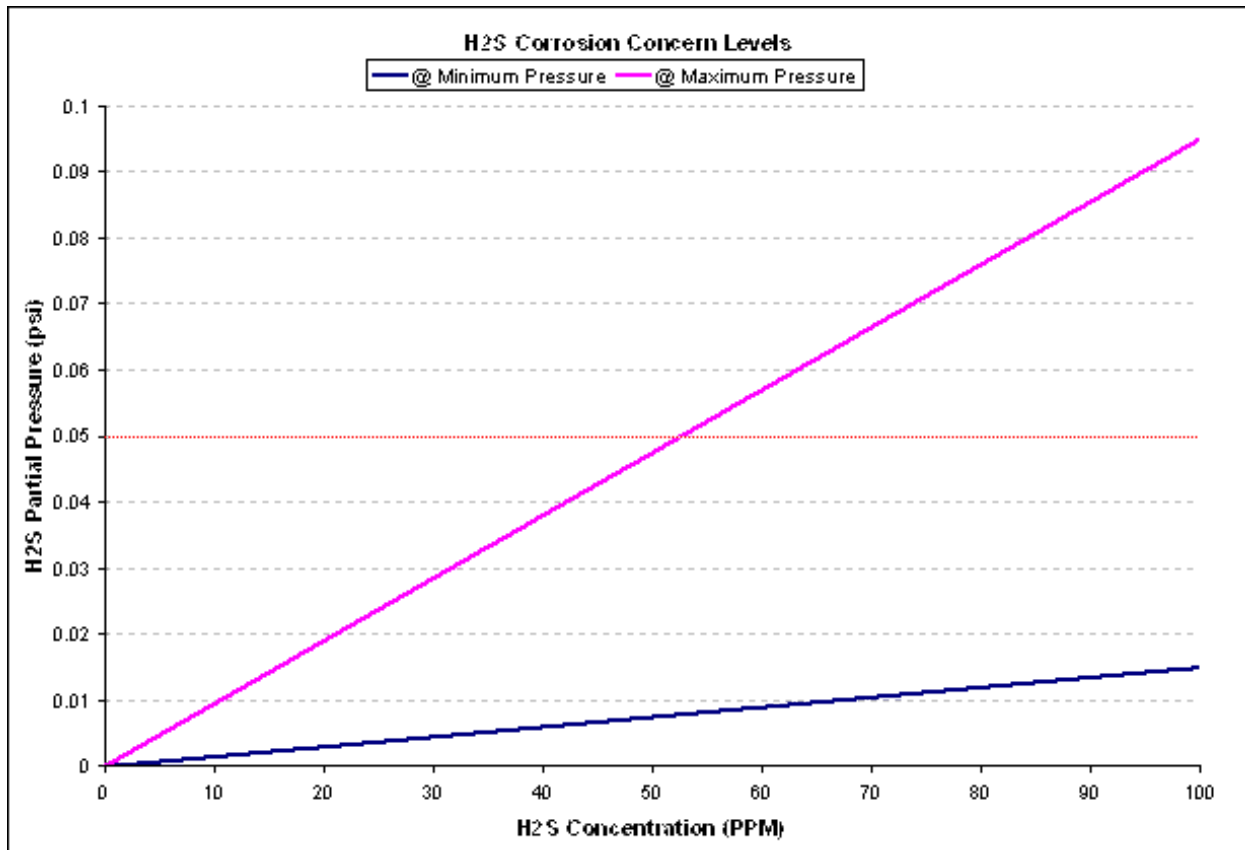

Figure 2. Example of H₂S Corrosion Concern Level using Total Pressure and H₂S Concentrations

(e) Shown in the table below are concern levels for internal corrosion due to elevated levels of H₂S. Gas maintained at tariff quality is considered a low concern for internal corrosion due to H₂S. Furthermore, partial pressures below 0.05 psia are considered a low concern for sulfide stress cracking^[1].

H ₂ S (ppmv)	Level of Concern
< 50	Low Risk
50 - 200	Moderate Risk
> 200	High Risk

(3) O₂ - Oxygen

(a) Oxygen within a gas stream containing water will accelerate corrosion pitting. O₂ is measured by an oxygen analyzer.

(b) It can also be evaluated as an additional component of gas chromatograph analysis.

(c) Alternatively, special stain tubes may be used to test for O₂ content.

(d) If O₂ is indicated, it is necessary to determine the dissolved O₂ concentration in water when it is present. A dissolved O₂ concentration above 10 to 50 ppm can be considered corrosive

(e) to steel pipelines. Refer to section [8 - Gas Unit Conversions](#) below for unit conversions commonly used for gas analysis.

(f) The restriction for transported gas from suppliers ranges from 20 to 50 ppmv.

(g) NACE standard practice states that companies shall make reasonable efforts to maintain the gas free from oxygen if the oxygen level exceeds 1000 ppmv (0.1 Vol.%).

(h) As a caveat in cases where oxygen is found in natural gas samples, there is always the possibility that air contamination might have occurred during the sampling process or at the laboratory during analysis. To obtain additional oxygen concentration information it is recommended to use an oxygen sensor instrument at the sampling site.

(4) Water Vapor

(a) Water content in the gas stream can be measured with either a stain tube or an electronic meter. Both of devices determine the amount of water in pounds per million cubic feet (lbs/MMSCF) of the gas.

(b) A value of less than 7 lbs/MMSCF is generally considered non-corrosive. At higher concentrations and certain pressure and temperature conditions, it is possible for free water to condense.

(c) Water content is continuously monitored downstream of the dehydration system.

(d) Upstream of the dehydration system (e.g. at the wellheads), the gas may be considered water saturated.

(e) Testing water vapor content at various wellheads can help quantify the level of water saturation within a given storage field. This additional testing may be performed at the discretion of the Corrosion Control personnel.

(5) Additional testing

(a) Heating value, relative density and hydrocarbons are typically obtained from laboratory samples.

(b) The heating value identifies the quality of the gas by measuring the amount of [heat](#) released during the combustion of a specified amount.

(c) Hydrocarbons are analyzed by the laboratory to identify the main components of the gas.

8. Gas Unit Conversions

A. The constituents analyzed in the gas stream may be reported in several different units. This section identifies the different equations used to perform unit conversions for the various constituents.

B. First equation uses the percentage, typically reported by a laboratory, and gas pressure to calculate the partial pressure.

$$\text{Partial Pressure} = \frac{\text{mole \%} \times \text{total pressure}}{100}$$

C. The percentage of the constituent may also be converted into parts per million (PPM), using the following equation:

$$\text{Parts Per Million (PPM)} = \frac{\text{mole \% O}_2 \times 10^6}{100}$$

D. The last equation uses typically reported by a stain tube or an electronic meter, to convert to the partial pressure of the constituent in the gas.

$$\text{Partial Pressure} = \frac{\text{PPM} \times \text{total pressure}}{10^6}$$

9. Liquid Samples

A. The composition of liquids removed from the piping and equipment is information useful in estimating corrosivity. Since corrosion requires an electrolyte, there will be no internal corrosion where no liquids are present.

B. Measurement and analysis of liquids from the piping along with knowledge of the original water composition within the formation can be used to predict changes in corrosivity or corrosion mechanism due to changes in process conditions.

C. Measurements of interest include temperature, pressure, alkalinity, pH, dissolved H₂S, dissolved CO₂ and metal/cations and anion analysis (lab).

D. Composition determined from analysis can improve corrosion monitoring efforts by identifying corrosion products. Refer to [GSIC 2.03](#) - Collecting and Testing of Fluids Samples, for additional information.

E. Sample Locations & Methods

(1) Sampling locations are chosen so that data represent the majority of liquids within the system being monitored. They should also represent locations where internal corrosion is expected to be most aggressive as may be determined by previous experience, inspections of the system piping and equipment or as predicted by integration of data collected through this monitoring program.

(2) Typical sampling locations to consider include the following:

(a) Drips (pipeline, meter station, compressors, etc.)

(b) Vessel/header drain lines

(c) Liquid recovery vessels (well head separators, slug catchers, scrubbers)

(d) Dead end sections of pipe with no flow

(e) Pig launchers and receivers

(f) Tanks

(g) Meter tubes

(h) Low areas (sags, river crossings, etc.)

(i) Side streams and sample loops

(3) Testing for corrosion information is performed in accordance with [GSIC 2.03](#) - Collecting and Testing of Fluid Samples. Field-testing should be completed within four (4) hours of collection and, if possible, samples should be analyzed within thirty six (36) hours.

(4) If a full sample size (i.e. 3 - 4 ounce bottles) is not available, the number of tests may be limited in order to optimize the type and quantity of results obtained. Priority should be given to pH, temperature, and bacteria tests.

(5) Analysis for Internal Corrosion Indicators

F. Field Tests

Although field analysis of withdrawn liquids tends to be less precise than laboratory testing, the lesser accuracy is offset by the fact that some parameters can change over time or after

UNCONTROLLED IF PRINTED

removal from the pipeline environment. Therefore, the following recommended tests should be performed immediately after a liquid sample is collected.

(1) pH

The pH of the liquid water is determined by a pH meter or pH (litmus) paper. This is an important field measurement because it will change following depressurization and when there are significant levels of dissolved iron in the liquid. Low pH levels, such as 5.0 or less, may result in increased corrosion.

(2) Temperature

Temperature is measured using a thermometer or electronic instrument that has an appropriate range. A "rule of thumb" is the corrosion reaction rate doubles for every 10°C (18°F) increase in temperature.

(3) Bacteria

(a) Bacteria testing should be started immediately upon sample collection because levels of viable bacteria may increase or decrease in a few hours.

(b) Bacteria cultures are injected into a dilution series and, depending on the reaction observed after the incubation period (APB 5 to 14 days, SRB greater than 28 days) the total number of bacteria colonies per liter are determined.

(c) When found in a liquid sample, bacteria are typically described as planktonic; sessile bacteria are typically found in solid or sludge samples. Planktonic bacteria of 1000 colonies per ml are considered a concern for corrosion (SRB or APB).

(d) In some cases, the liquid sample may be preserved in the field for laboratory analysis to determine the exact type of bacteria present. This additional testing would be done at the discretion of the Corrosion Control personnel.

10. Additional Tests (Optional)

A. Total alkalinity, dissolved H₂S, and dissolved CO₂ are typically obtained from laboratory samples. However, field test kits are available for situations when immediate results are desired.

B. For example, root cause investigations might warrant use of these tests rather than waiting for lab analysis to issue preliminary findings.

C. The relative complexity of performing these tests and/or the subjective nature of the results makes these impractical to run for every sample.

(1) Total Alkalinity

(a) Alkalinity is a pH dependent factor that will also change as the pH changes.

(b) This test is performed with a HACH Alkalinity test kit (or equivalent).

(c) Alkalinity is determined by counting the number of drops required to activate Phenolphthalein or Bromocrescol Green-Methyl Red indicators.

(d) If the pH test result is less than 4.5, the total alkalinity test is unnecessary and the value is assumed to be zero.

(2) Dissolved H₂S

(a) This test is performed in the field because H₂S leaves the sample after depressurization.

- (b) Two different field test methods are available and should be used depending on the volume and cleanliness of the water sample.
 - (c) If at least 100 mL of liquid is available to test, a HACH Hydrogen Sulfide test kit should be used. This test determines H₂S concentration by comparing exposed test papers to a color chart.
 - (d) If less than 100 mL of liquid is available to test, a test kit may be used. This test determines H₂S concentration by comparing an activated solution in an ampoule to a color chart.
 - (e) Refer to [GSIC 2.03](#) - Collecting and Testing of Fluid Samples for recommended test kits.
- (3) Dissolved CO₂

The test kit for measuring the amount of CO₂ in the sample solution should be used as soon as practical after sample collection since the CO₂ will be liberated from the sample due to the pressure reduction. Refer to [GSIC 2.03](#) - Collecting and Testing of Fluid Samples for recommended test kits

11. Laboratory Tests

The primary purpose of laboratory testing is to determine the composition of the liquid sample. Most results are reported as concentration in parts per million (ppm). Recommended tests performed are summarized below.

A. Metal/Cations Analysis

(1) This test determines the concentration of common cations, which are positively charged ions. Knowing the type and concentration of these ions present helps predict the formation of deposits, or when combined with other information, indicate corrosion is occurring. Common cations used for analysis are:

- (a) Calcium
- (b) Barium
- (c) Iron
- (d) Magnesium
- (e) Manganese
- (f) Potassium
- (g) Sodium
- (h) Strontium

(2) Iron and/or manganese can also be naturally occurring in the water produced therefore not all concentrations are indicative of internal corrosion. Once a typical composition for a given well formation is established, any concentrations outside of this "normal" range can be flagged as a concern.

(3) Generally speaking, the ratio between iron and manganese within a particular formation should hold relatively constant therefore a high Fe to Mn ratio could also be indicative of internal corrosion. A typical concern level for Fe/Mn ratio would be 0.017.

B. Anion Analysis

(1) The concentration of common anions (negatively charged particles) is the result of this test.

(2) The type and concentration of anions in the sample can be used to predict acceleration of corrosion pit initiation (such as when chloride ions are present) or inhibition of corrosion activity (such as when phosphate ions are in the liquid).

(3) Common anions used for analysis are:

(a) Chlorides

(b) Sulfates

(c) Sulfides

C. Alkalinity

(1) Carbonate, bicarbonate and hydroxide ions determine the alkalinity of the liquid. These can neutralize acids and act as a pH buffer.

(2) Bicarbonate and carbonate ions, together with cations such as calcium or iron, form commonly found scale. In general, corrosivity tends to decrease as alkalinity increases.

D. pH

The pH of a sample is the negative logarithm of the hydrogen ion concentration in an aqueous medium. The pH will indicate whether a sample is acidic (< 7), neutral (~7) or alkaline (>7).

E. Total Dissolved Solids (TDS)

(1) TDS are the sum of all dissolved ions (cations and anions) detected in the analysis of an aqueous liquid.

(2) This value can be used to verify the completeness of an analysis based on the sum of each of the individual constituents of the sample should approximate the total dissolved solids value.

F. Miscellaneous

Other tests may be specified at the discretion of the Corrosion Control personnel.

(1) Remaining inhibitor concentrations may help monitor the effectiveness of an inhibitor program.

(2) Specific gravity may be useful in determining the root cause of internal corrosion.

(3) Glycol scans can be performed to detect the total amount (as a percentage) of alcohol type compounds contained within a liquid sample such as methanol, various ethylene glycols, isopropanol and propylene glycol.

(4) The presence of glycol may indicate upsets or carryover from dehydration, which may also introduce water, chlorides and other corrosive contaminants into the system.

12. Analysis of Sludge or Solid Samples

A. Whenever sludge or solids are removed from a pipeline or equipment, collect a sample of the material according to [GSIC 2.01](#) - Internal Corrosion Examination.

B. Perform field tests for pH, sulfides and bacteria. Samples are sent to a laboratory for a complete compositional analysis including anions, cations, metals, organics, iron carbonate (FeCO₃), and iron sulfide (FeS) If there is liquid in the sample, determine if it is water, which supports corrosion, or hydrocarbons.

C. Field Tests

Field tests for pH, bacteria, and sulfides are performed immediately after sample collection. Once the line or vessel is opened and the sample exposed to the outside environment, conditions begin to change. Therefore, it is essential to take these readings as soon as possible:

(1) pH

(a) The pH of the solid or sludge is determined by a pH meter or pH (litmus) paper.

(b) This is an important field measurement because it will change following depressurization and when there are significant levels of dissolved iron in the liquid. Low pH levels, such as 5.0 or less, may result in increased corrosion.

(2) Bacteria

(a) Because levels of viable bacteria may increase or decrease in a few hours this test should begin immediately upon sample collection.

(b) Bacteria cultures are injected into a dilution series and, depending on the reaction observed after the incubation period (APB 5 to 14 days, SRB greater than 28 days) the total number of bacteria colonies per liter are determined.

(c) When found in a liquid sample, bacteria are typically described as planktonic; sessile bacteria are typically found in solid or sludge samples.

(3) Sulfides and Carbonates

(a) The presence of sulfides or carbonates in a solid sample can be detected by adding a small amount of hydrochloric acid (or other strong acid) Bubbling indicates a positive test for carbonates.

(b) Lead acetate test paper is then used to test for sulfides.

D. Laboratory Tests

(1) Compositional data may be useful in determining the corrosivity of the internal pipeline environment.

(2) If a sample of solids contains a large fraction of Iron Sulfide (FeS), also known as "black powder", it may smolder and/or ignite when exposed to air. Caution is required for shipping such a sample as well as handling it during clean out in the field.

(3) Analyze the sample for the following compositional data:

(a) Alkalinity

Alkalinity measures the amount of constituents (bicarbonates, etc.) in water that neutralize acids and act as pH buffers. When alkalinity increases, corrosivity tends to decrease.

(b) % Ash

Percent ash is the amount of non-[aqueous](#) residue that remains after a sample is [burned](#), which consists of mostly metal [oxides](#). (Non-volatile)

(c) Chloride, soluble

i. Chlorides tend to exacerbate localized corrosion (pitting-type) when in contact with steel for extended periods.

ii. Most are quite soluble in water, therefore they will only be found in samples where fluids high in chloride ion concentrations encounter dry conditions preventing them from deliquescing.

iii. Chlorides can interact with hydrogen ions to form HCl and lower the pH.

UNCONTROLLED IF PRINTED

(d) Metals (Calcium, Barium, Iron, Magnesium, Manganese)

i. Iron found in a solid sample that has accumulated in vessels, loosened during cleaning pig runs, or debris found when a cutout is made on the line typically represents corrosion product.

ii. When considering Iron, manganese should also be noted. A large manganese to iron ratio usually reflects corrosive conditions.

iii. Large amounts of calcium, barium and magnesium indicate scaling.

iv. Magnesium can form corrosive scales with chlorides and sulfates. Magnesium carbonate is a protective scale.

v. Calcium can form acidic or alkaline scales as well. Calcium carbonate is protective, while calcium sulfate and calcium chloride are corrosive.

vi. Barium sulfate is a problematic scale which deposits on steel and is extremely difficult to remove once formed. Once adhered to the pipe, corrosive conditions are likely to occur beneath the scale.

(e) pH, slurry

The pH of a sample is the negative logarithm of the hydrogen ion concentration in an aqueous medium. The pH will indicate whether a sample is acidic (< 7), neutral (~7) or alkaline (>7).

(f) Sulfate, soluble

Sulfate salts are acidic and can impact corrosion, especially causing localized under-deposit or crevice corrosion.

(g) Sulfide

i. The corrosion rate and formation of iron sulfide is relatively general when their amounts are nearly equal.

ii. When the amount of sulfide is considerably less than iron, iron sulfide formation is less likely; therefore, the impact of sulfide corrosion is deemed minimal.

iii. If the opposite is true, iron sulfide is readily formed and there has been significant sulfide influenced corrosion.

13. Corrosion Monitoring

A. Corrosion Coupons

(1) A corrosion coupon is a small, carefully weighed and measured specimen of metal inserted into the pipeline or vessel and exposed to the internal environment for a specified period of time.

(2) The difference in the weight of the coupon before and after exposure can be converted into a general corrosion rate at that point in the piping system.

(3) Instructions for coupon removal and installation are provided in [GSIC 2.02](#) - Monitoring Corrosion Weight Loss Coupons.

(4) In general, corrosion coupons are installed in representative locations and/or the most severe internal corrosion location anticipated or known from prior experience.

(5) At a minimum, AIC installs a single corrosion coupon, ER probe, or other corrosion monitoring device at each storage field. Storage fields having a higher known corrosivity will have multiple coupon or probe locations.

(6) The corrosion rate for each coupon is expressed in mils per year (mpy) and calculated from the difference between the starting and ending weights, the surface area of the coupon, its density and the time it was exposed to the internal environment of the pipeline.

$$\text{CorrosionRate (mpy)} = \frac{22.25}{DAT} \times \Delta W$$

Where,

ΔW = Change in Weight (mg)

D = Density of the coupon (g/cm³)

A = Area of the coupon (in²)

T = Exposure Time (days)

(7) Based on NACE RP0775-2005, a qualitative guideline for the interpretation of measured corrosion is given below.

Corrosion Rate (mpy)	Level of Concern
< 1	Low Risk
1 - 5	Moderate Risk
> 5	High Risk

(8) Coupons are to be evaluated twice per calendar year but with intervals not to exceed 7½ months. Coupons are not to be re-used after removal.

(9) One set is inserted at the end of the withdrawal season and removed and analyzed at the end of the injection cycle to monitor potential corrosion during injection.

(10) The coupons that replace this set are left in place through the injection/withdrawal period before removal for measurement.

B. Electronic Corrosion Probes

(1) Electronic probes can measure corrosivity in real time and without needing to be removed from the pipeline. Location on the pipeline is generally the same as for coupons.

(a) An electrical resistance (ER) probe determines metal loss by measuring the increase in the electrical resistance of an electrode as corrosion reduces its cross sectional area over time.

(b) Continuous electrolyte is not required for this type of probe to operate making it a good choice for placement in a gas stream.

(c) ER probes are not intended for monitoring pitting.

(d) Fouling of the probe by deposits (e.g., iron sulfide) may affect its accuracy.

(2) Linear polarization probes (LPR) instantly determine corrosion rate by measuring the degree of resistance to a small applied voltage.

(a) The LPR must be submerged in electrolyte in order to operate limiting its possible placement to locations that normally contain a liquid.

(b) These probes can be fouled by hydrocarbon liquids.

UNCONTROLLED IF PRINTED

(3) AIC currently utilizes ER probes at all storage fields. LPR probes are being used at one AIC storage field.

(4) Where both coupon and probe data is available, the relative corrosion rates are compared.

(5) The output from an ER probe is a signal proportional to the element's metal loss. The corrosion rate is then calculated using multipliers specific to the probe type. Corrosion Rate can then be expressed as the change in metal loss over time.

$$\text{CorrosionRate (mpy)} = \frac{P \times 365}{1000} \times \frac{\Delta S}{\Delta t}$$

Where,

P = Probe Multiplier (dimensionless)

ΔS = Change in Signal (dimensionless)

Δt = Time between Readings (days)

C. Ultrasonic Thickness (UT) Survey

(1) An UT survey is a useful method for determining corrosion rate information, remaining life and the extent of any internal corrosion damage of various pressure equipment and piping with the storage fields.

(2) Generally, the UT survey is performed at wellhead water knockout vessels, wellhead sweep piping, station piping and dead ends (where liquids may accumulate).

(3) The UT survey procedure would include:

(a) Ultrasonic - "A" Scan with remote data acquisition. All test point locations should be scanned by continuous coupling to the test item. The average scan incorporates a 2" minimum wide test band at the critical locations. The lowest reading should be recorded, localized and documented for assessment.

(b) Areas that reveal unusual metal loss should be addressed within the "comments" section of the report and summary.

(c) Calibration - All ultrasonic sets should be calibrated in accordance with standard Vertical and Horizontal Linearity specifications.

(d) Surface Preparation - All Oxides, scale, loose paint, etc. shall be removed by scraping.

(4) UT surveys typically utilize a third-party contractor and performed once per calendar year. At a minimum, the person performing the UT Survey should have ANST Level 2 and API 653 certifications. Personnel assisting under the direction of a qualified individual do not require ANST Level 2 or API 654 certifications.

(5) The surveys are performed per contractor's specifications unless otherwise directed by the Corrosion Control personnel.

Note: [GSIC 2.01, Section 5 - Ultrasonic Thickness Testing](#), does not cover annual UT survey requirements.

(6) If desired, a Fitness-For-Service (FFS) may be performed in addition to the standard UT survey. FFS requires more data points and more detailed examination when significant wall loss is found. Results are analyzed by a qualified individual per API 579-1/ASME FFS-1.

(7) Inspection intervals for each location are determined based upon the corrosion rate and remaining wall thickness data. After two or more data points are accumulated for each test location, a corrosion rate can be calculated to determine the frequency of future UT testing.

$$\text{Corrosion Rate (mpy)} = \frac{WT_2 - WT_1}{\Delta t} \times 1000$$

Where,

WT = Average Wall Thickness (inches)

Δt = Time between Measurements (years)

(8) The frequency of testing can be the lesser of either one-half the Remaining Life or at an interval specified by AIC personnel.

(9) The table below identifies the risk for the various corrosion rates established by the UT survey. These should be used to determine the frequency of testing.

Table 1. UT Survey

Corrosion Rate (mpy)	Total Wall Loss (%)	IC Risk
< 1.0		Low
1.0 ≤ Rate ≤ 5.0		Moderate
> 5.0	> 20%	High

(10) Ideally, a second UT survey would be performed one year after the initial baseline survey in order to determine a corrosion rate for each location. However, at the discretion of Corrosion Control personnel, if the baseline survey reveals the vessel or piping to be in good condition (i.e. at or above nominal wall thicknesses) the second survey may be postponed.

14. Corrosion Rate and Remaining Life

A. Corrosion Growth Rate

(1) When possible, the corrosion rate should be determined by directly comparing measured wall thickness measurements over a known time interval.

(2) The use of coupons is another relatively direct measurement technique.

(3) Both, however, are limited in that only averages are calculated and may present an inaccurate picture in changing or volatile conditions.

(4) If multiple corrosion rate data points are available for the same location, they should be used in the following order of precedence: UT survey, Corrosion Coupons, ER Probes.

(5) Since direct measurement is frequently not practical, a corrosion rate may be estimated by considering "like/similar" areas of the piping system where a rate is more likely to be known.

(a) "Like/similar" areas contain the same pipe material, transport the same product and experience virtually the same flow and operating conditions.

(b) Comparison of the results of sampling performed on specimens removed from the piping should aid in this analysis.

B. Remaining Life

(1) The remaining strength of a corroded pipe is determined by use of ASME B31G, Manual for Determining the Remaining Strength of Corroded Pipelines or the AGA Pipeline Research Committee, Project PR-3-805, A Modified Criterion for Evaluating the Remaining Strength of Corroded Pipe (with RESTRENG) Limitations are also specified in the procedures.

(2) In order to calculate the remaining life, the depth of the corroded areas (i.e. remaining wall thickness), length of the corroded areas, pipe diameter, grade and wall thickness need to be known.

(3) One of the outputs of the remaining strength methods is the maximum safe pressure (calculated failure pressure) of the pipe in its corroded condition. This value is needed to calculate the remaining life of the facility in accordance with the following equation per NACE SP0502-2008:

$$\text{Remaining Life (years)} = 0.85 \times \left(\frac{P_{fail}}{P_{yield}} - \frac{MAOP}{P_{yield}} \right) \times \frac{WT}{1000 \times GR}$$

Where,

P_{fail} = Failure Pressure (psi)

P_{yield} = Yield Pressure (psi), [2·SMYS·t/OD]

MAOP = Maximum Allowable Operating Pressure (psi)

WT = Wall Thickness (inches)

GR = Growth Rate (mpy), [Note: The equation as written above accounts for Growth Rate in mils per year instead of inches per year.]

15. Examination of Exposed Surfaces

A. Anytime the inside of a pipeline is exposed for any reason, the internal surfaces must be inspected for evidence of corrosion. This will include when pipe is cut out, spool pieces are removed, valves or other flanged equipment is taken out of the line and similar situations.

B. When pipe is tapped and the tapping coupon is retrieved, its inside surface should also be inspected.

C. Visual examination should be done as soon as possible after the internal surface is exposed. Changes to deposits and corrosion products, if present, occur when exposed to air, light and moisture.

D. The inspection involves more than a simple determination of pipe wall thinning or pitting due to internal corrosion.

E. Other evidence from inside the pipe needs to be collected and analyzed to establish the root cause and point toward a mitigation strategy.

F. Examination for internal corrosion should be performed in accordance with [GSIC 2.01](#) - Internal Corrosion Examination and documented on applicable form.

16. Root Cause Analysis

If it appears that internal corrosion has occurred at the location and a more detailed investigation is warranted, the following additional pieces of information above and beyond what is collected on [Form GSIC-2.01-1](#) may be required in order to perform a root cause investigation:

- A. Physical location information - The piping configuration upstream and downstream may also be useful
- B. Potential source liquids - sampled from upstream locations, when applicable, for laboratory analysis
- C. Operating history data - obtained from appropriate sources
- D. Pipe sample - preserved for laboratory analysis

17. Data Trending

- A. Internal corrosion is dependent upon a variety of factors including physical layout of the system and chemical composition of the gas transported.
- B. The following data sets provide the strongest correlation to internal corrosion risk and therefore are used to benchmark risk within each storage field as well as compare conditions between fields.
 - (1) History of Internal Corrosion - leaks, ruptures, or repairs required due to internal corrosion (if available)
 - (2) Corrosion Rate - high / moderate / low per UT survey, corrosion coupon, &/or ER probe data
 - (3) H₂S - high / moderate / low based on ppm concentration
 - (4) CO₂ - high / moderate / low based on partial pressure
 - (5) Bacteria - Acid Producing Bacteria (APB) or Sulfate Reducing Bacteria (SRB) colony count of 1,000/mL or more
- C. Each data component is a useful tool that when taken as a whole, the data can be used to focus additional corrosion monitoring, mitigation, maintenance or repair activities.

18. New or Revised Piping

- A. Construction of new piping or modifications to existing pipelines may affect the potential for internal corrosion at virtually any location within the storage field.
- B. Care should be taken to evaluate such changes in view of regulatory requirements for the design and construction of the components.
- C. In addition, at least initially, the internal corrosion monitoring program may need to be modified until the effect of the piping changes becomes clear.
- D. Each new transmission line or replacement of line pipe, valve, fitting, or other line component in a transmission line must
 - (1) Be configured to reduce the risk that liquids will collect in the line;
 - (2) Have effective liquid removal features whenever the configuration would allow liquids to collect; and

(3) Allow use of devices for monitoring internal corrosion at locations with significant potential for internal corrosion.

E. When changes to the configuration of a transmission line are made, the impact of the change on internal corrosion risk to the downstream portion of existing piping must be evaluated.

F. Provisions for removal of liquids and monitoring of internal corrosion as appropriate are required.

19. Documentation

A. Records relating to internal corrosion are filed and maintained as follows and should be maintained for the life of the pipeline.

(1) Routine / Regular Maintenance

(2) Facility (Storage Field)

(a) Well

(b) Pipeline Segment

20. Data for Audits and Reviews

A. Records should be kept in a central location and easily referenced in order to simplify audit preparation.

B. Current and historical test data for each storage field will be filed under facility, specific to wellhead name or pipeline segment.

C. Monitoring Records:

(1) Coupons - location and frequency of coupon monitoring

(2) Gas Samples - location and frequency of sampling, type of analysis performed (CO₂, H₂S, O₂, water vapor), CO₂ corrosivity ranges

(3) Water/Liquid Samples - frequency and location of sampling, constituents analyzed, threshold criteria used

(4) Solids Samples - location and frequency of sampling (at pig receivers), presence of iron oxide (Fe_xO_x), iron Sulfide (FeS), scale, or sand

(5) Instrumented Inspection Surveys - lines surveyed, frequency

D. Mitigation Records:

(1) Inhibitor Programs - program start date, treatment type, inhibitors used

(2) Maintenance Pigging - routine pigging program in place at various storage fields

(3) Gas Velocity Control

E. Operation Records:

(1) Pressure, Flow, and Temperature - maximum and minimum for both injection and withdrawal

(2) Water, CO₂ and O₂ Content - for both injection and withdrawal

(3) Leaks and Leak Surveys - 5 year history

UNCONTROLLED IF PRINTED

- (4) Failures and Ruptures - 5 year history
- (5) Upsets - 3 year history by type and cause

F. Basic Storage Information:

- (1) Compressors
- (2) Dehydration
- (3) Sweeting
- (4) Scrubbers / Separators
- (5) Draining/blowing frequency

G. Miscellaneous Information:

Any well treatments (e.g. fracturing or acidizing) must be summarized.

[1] NACE MR0175-2002. Sulfide Stress Cracking Resistant Metallic Materials for Oilfield Equipment.

GAS STORAGE INTERNAL CORROSION MONITORING
GSIC 1.02 Safety Considerations

April 1, 2023

1. Objective

A. This section describes Safety Considerations when performing monitoring tasks and inspection activities related to metallic piping systems and associated appurtenances such as vessels, for the precursors to and effects of internal corrosion.

B. The processes and procedures contained in this section are applicable only to storage field gathering system piping and related appurtenances carrying dry gas, wet gas or both. Internal corrosion control for pipelines outside of the storage fields is covered in [CORR 1. Ameren Illinois' \(AIC\) Operation and Maintenance \(O&M\) Plan](#).

2. Part 192 Reference

49 CFR §§ 192.475, 192.476, & 192.477

3. Safety Considerations

A. Follow all applicable Company safety procedures including those related to ACIG - accidental ignition, CONF - confined space entry, DAMG - damage prevention, and EXCV - excavation safety when excavating pipe and facilities.

B. Ensure appropriate Personal Protective Equipment (PPE) is used specific to the job being performed.

C. Always use latex (or similar) gloves and appropriate eye protection when collecting and testing liquid or corrosion (MIC) samples.

D. Storage field testing may involve controlling gas at elevated pressures. Use appropriate tools and equipment to prevent instruments and pipe plugs from uncontrolled movement which may cause injury during removal or installation.

E. Discontinue work when thunderstorms are in the area. Lightning strikes at remote distances can create hazardous voltage surges on the pipeline.

F. Do not allow natural gas to accumulate in confined areas or come in contact with potential ignition sources. Natural gas displaces oxygen in confined areas and is an ignition hazard when operating electronic devices which are not Intrinsically Safe or otherwise classified.

G. ER/LPR probe and trace oxygen data collection is performed using a probe specific electronic device which is Intrinsically Safe. Follow manufacturing instructions.

H. Review and understand the appropriate Safety Data Sheets (SDS) when applicable. Consult with a qualified Safety Compliance Engineer regarding interpretation.

I. Take appropriate safety precautions when performing direct examinations.

J. When near venting gas, be aware of the wind direction and park vehicle(s) accordingly. Turn off the vehicle(s) and/or any electronic device(s).

K. Ensure gas is vented away from personnel performing testing.

L. H₂S can be a health hazard even in low concentrations. Personnel should utilize an H₂S monitor when performing gas sampling and testing at storage facilities with a history of H₂S.

M. Contractors should notify responsible Company personnel prior to performing work including collecting samples.

UNCONTROLLED IF PRINTED

4. Documentation

Documentation relating to Damage Prevention (locate, JULIE), confined space entry (permit), excavation safety (dig record with excavation dimensions, soils checklist) and monitor calibration, concentration measurement should be retained.

GAS STORAGE INTERNAL CORROSION MONITORING
GSIC 2.01 Internal Corrosion Examination

April 1, 2023

1. General

A. This procedure provides a standard method of collecting and recording data during examination of pipe for internal corrosion whenever pipe is removed from the gas system.

B. The processes and procedures contained in this section are applicable only to storage field gathering system piping carrying dry gas, wet gas or both. Internal corrosion control for pipelines outside of the storage fields is covered in [CORR 1](#). Ameren Illinois' (AIC) Operation and Maintenance (O&M) Plan.

2. Part 192 Reference

49 CFR 192.475(b)

3. Safety Considerations

Please refer to [GSIC 1.02](#) - Safety Considerations.

4. Site Conditions

A. Consideration should be given to collecting information about site conditions before, during and after excavation.

B. Excavation activities may destroy some site condition evidence therefore consideration should be given to taking photographs and measurements prior to excavation.

C. Photographic considerations may include, but not be limited to:

- (1) The site prior to excavation / exposure
- (2) The site during excavation / exposure
- (3) The internal surface of the cut-out, if applicable
- (4) Any corrosion product that is present
- (5) The internal surface of the pipe on either side of the cut-out, if applicable
- (6) Pipe after replacement / repair
- (7) Site after backfill and restoration

D. Consideration may be given to documenting the general site conditions found prior to excavation on [Form GSIC-2.01-1 - Storage Internal Corrosion Examination](#):

- (1) Topography, drainage, and land use.
- (2) Footage measurement to the centerline of the excavation / exposure from a known reference point such as a road centerline, valve, meter station, etc.
- (3) GPS coordinates of the excavation site if equipment available.

E. If acquired, ensure the following information is documented on the applicable form during / after pipe exposure:

- (1) Length of excavation / exposure.

UNCONTROLLED IF PRINTED

- (2) Pipeline depth of cover. If depth of cover varies significantly within the exposure, additional depths or a sketch may be provided.
- (3) Whether the inspection is at or near a low spot.

*Note: Refer to **CORR 1 Appendix A** - Buried Pipe Examination procedures to document external conditions. This should be performed prior to removing the coating.*

F. If possible, determine the pipeline inclination angle and record on [Form GSIC-2.01-1, Storage - Internal Corrosion Examination](#).

- (1) Ensure the pipe surface is clean of dirt and debris for at least two (2) inches more than the length of level.
- (2) Use a factory-coated length if accessible to ensure the pipe wall is as smooth as possible when taking angle measurements.
- (3) Locate and mark an initial Top Center of Pipe location and its affiliated direction (north, south, east or west).
- (4) Locate and mark a second Top Center of Pipe location at a point that is at least two (2) inches longer in length than the level and indicate its affiliated direction (opposite direction as the initial location based).
- (5) If an electronic level is available, measure the inclination angle directly on the pipe with the level centered between the Downstream and Upstream marks.
- (6) If an electronic level is not available, use the following manual bubble level technique.
- (7) Place a bubble level centered between the downstream and upstream marks.
- (8) Place the level directly onto the pipe or set on a straight edge placed on the pipe.
- (9) Adjust the level or straight edge with an angle wedge so that it is leveled using the level bubble indicator.
- (10) Measure the elevation difference from the pipe surface to the level using calipers or other approved device.
- (11) Calculate the Pipeline Inclination Angle using the following equation.

$$P_{in} = \arctan (El_m / L_l)$$

where:

P_{in} = Pipeline Inclination Angle, degrees

El_m = Measured elevation difference

L_l = Length of level

- (12) If using an Excel spreadsheet, the result for P_{in} will be in radians. Multiply P_{in} by 180 divided by pi (π) to obtain degrees (cell * 180/pi()).

5. Ultrasonic Thickness Testing

A. Ultrasonic Thickness (UT) readings may be taken during examination of a pipeline or vessel to determine or verify the presence of internal corrosion.

B. This document provides a standard method of collecting and recording data during ultrasonic testing of pipe for internal corrosion.

C. To ensure good contact between the transducer and the surface, prepare the area to be examined.

(1) For UT instruments capable of deducting coating thickness, clean the coating using a cloth and water prior to examination.

(2) For Ultrasonic instruments not capable of deducting coating thickness, metal surface must be free of corrosion or mechanical deformities.

D. Clean away any contaminants present with a clean, dry, stiff brush.

(1) If not all the contaminants can be removed with this method, use a wire brush.

(2) The surface to be examined must be free of rust, scale, welding flux, weld spatter, grease, oily films and dirt.

E. Prepare the area so that the transducer contact face can be held parallel to the inside diameter surface.

F. Perform ultrasonic thickness measurements around the circumference of the pipe. Document readings on [Form GSIC-2.01-1](#).

(1) If a girth weld is exposed, perform ultrasonic thickness measurements on each side of the weld so that each joint of pipe is tested.

(2) Take readings at the 12, 3, 6 and 9 o'clock positions approximately one (1) foot apart for the length of the exposed pipe.

(3) If additional detail on wall loss is required, take readings using a one (1) inch grid from the 4 o'clock position to the 8 o'clock position on the pipeline at each of the circumferential locations.

(a) Internal corrosion is more likely in areas where liquid collects at the bottom of the pipe.

(b) Pipe to be removed from service or cut out does not require 1" gridding.

(4) If wall loss is found throughout the gridded area, extend the one (1) inch grid 360° around the pipe circumference. Corrosion can occur at any internal location in the presence of wet gas.

(5) If corrosion or wall loss greater than 10% of nominal wall thickness is found on pipe that is not intended for replacement, contact Supervising Engineer, Gas Storage to determine if repair or replacement is necessary.

(a) Request the Supervising Engineer, Gas Storage (or designee) perform ASME B31G, Modified B31G or RSTRENG remaining strength calculations as applicable.

(b) Data necessary to complete these calculations includes:

- i. Diameter
- ii. Nominal Wall thickness
- iii. MAOP
- iv. Class location

v. Pit depth measurements

vi. Pit length (including interactive pits if applicable)

(6) Pits are considered to be interacting based on the following:

(a) Pits less than one-inch apart in the axial direction are classified as interacting.

(b) Pits less than 6 times the wall thickness (6T) apart in the circumferential direction are classified as interacting.

(7) Clearly mark cut-out locations on the pipe. If possible, do not cut where internal corrosion is present (i.e. cut on either side of the identified corrosion area).

6. Visual Examination

A. Whenever the internal pipe surface is accessible, visually examine the surface for evidence of corrosion, black powder, scale, or liquid.

B. Oxygen exposure will affect any bacteria present as well as degrade other testing relevant to internal corrosion; therefore the testing must happen as soon as possible to capture the status of the internal system.

C. If possible, make the cuts at locations without internal corrosion or use two or four wheel pipe cutter to prevent heat from the cutting torch affecting the internal corrosion condition. If pipe is split longitudinally use a cutting torch to obtain necessary samples for analysis.

D. If hydrocarbons are present, immediately test the internal surface of the pipe for the presence of PCBs. See [PCBH](#) - PCB Handling.

(1) Pipe cut-out segments should be preserved (refer to [Section 9 - Sample Preservation](#)) and remain on-site until test results confirm the absence of PCBs if necessary.

(2) Step "E" below should be performed prior to preserving the sample.

(3) If test results indicate PCBs are present, proceed according to [PCBH](#) - PCB Handling.

E. Immediately test the internal surface for the presence of MIC per [GSIC 2.06](#) - Field Testing for Bacteria (MIC).

Note: If pipe is cut with a cutting torch, or similar method, and the pipe is dry, testing for bacteria may not be possible.

F. Examine the internal surface of the pipe and collect and test samples per Sections [7](#) and/or [8](#) of this procedure.

G. Remove any scale or corrosion product from inside the accessible areas of the pipe using a clean, sterilized spatula or knife.

(1) Take care to not scratch the metal.

(2) The spatula or knife may be sterilized by rinsing with alcohol.

H. Visually examine the internal pipe surface and document findings on the applicable form.

(1) Examine the pipe surface for evidence of liquid hold-up. Estimate the extent of area affected by liquid hold-up.

(2) Note the presence of hydrogen sulfide (H₂S) or odorant "rotten egg" smell if observed.

(3) Examine the internal pipe surface for evidence of corrosion or scale.

(4) Document corrosion extent including the following information:

- (a) Type of damage (e.g. etching, pitting, general corrosion)
- (b) Minimum wall thickness in areas of most severe corrosion
- (c) Circumferential and longitudinal extent of corrosion
- (d) O'clock position of the corrosion
- (e) Location of deposits and corrosion under deposits
- (5) Document the presence and amount of scale or black powder.

1. If corrosion pitting is present inside pipe that is not intended for replacement, contact Supervisor Gas Storage or Corrosion Control personnel to determine if additional piping needs to be removed.

7. Sampling and Testing - Liquids

If liquid is observed during examination, perform the following tests.

A. Obtain a sample(s) of any liquid present inside the pipe for qualitative analysis. Refer to [GSIC 2.03](#) - Collecting and Testing Fluid Samples.

B. Analyze any fluid present inside the pipe for MIC per [GSIC 2.06](#) - Field Testing for Bacteria (MIC).

8. Sampling and Testing - Solids

If solid scale or corrosion product is observed during examination, perform the following tests.

A. Obtain a sample(s) of any corrosion product or scale for qualitative analysis.

(1) Collect the sample with a clean, sterilized spatula, knife, or other tool.

(a) The spatula or knife may be sterilized by rinsing with alcohol.

(b) Alternatively, collect the sample using clean latex or rubber gloves.

(2) Avoid touching the sample with bare hands or tools other than those cleaned for gathering the sample to prevent contamination.

(3) Place sample in a plastic jar with a plastic lid.

(a) Jars are typically four (4) or eight (8) ounces in size.

(b) Pack the sample jar full of material to displace air, if sufficient quantity is available.

(c) Alternatively, collect the sample in a clean double bagged Ziploc-type bag and compress the bags to displace the air when sealing.

(d) If possible, collect two separate samples. One good sample is better than two bad samples so requirements 8. A. (3)(b) and 8. A. (3)(c) will supersede this requirement.

(4) Tightly close the jar and seal with plastic tape (or seal the plastic bags after labeling).

(5) Label the jar or bag with the following information:

(a) Location and/or Line name

(b) Sample number (including date)

Example of sample numbering format as follows:

XX-MMDDYY-ZZ

UNCONTROLLED IF PRINTED

where,

XX = 2-letter code for storage field

MMDDYY = month, date, year

ZZ = 2-digit sequential number

Example: The first sample taken on July 16, 2011 at Johnston City storage field would be labeled **JC-071611-01**.

(6) Analyze any corrosion product for MIC per Gas Storage Internal Corrosion Monitoring [GSIC 2.06](#) - Field Testing for Bacteria (MIC).

B. Sample field test kits may be used on-site in lieu of laboratory analysis at the discretion of the Corrosion Specialist.

(1) Field test kits may also be used on samples collected as described in 8. A. above.

(2) If directed by the Corrosion Control personnel, analyze the corrosion product using a qualitative Chemical Species kit.

(3) Examples of test kits include, but are not limited to:

(a) Carbonates and Sulfide - (MSES SKU 575)

(b) Bubbling indicates a positive test for carbonates when a small amount of hydrochloric acid (or other strong acid) is added to the sample. Lead acetate test paper (e.g. MSES SKU 5018) can then be used to test for sulfides.

(c) Bacteria - MSES SKU 510, 520 or 530; Dixie Test Kit Number 4

9. Sample Preservation

A. Pipe segments removed from the line may be further examined to verify the extent and cause of internal corrosion.

B. This examination may be performed at a later date or sent to a laboratory for analysis if the samples are properly preserved.

C. After fluid and / or product have been sampled per above, carefully remove the remaining corrosion product from inside the cut-out using a clean spatula or knife.

D. Take care to not scratch the metal.

E. The spatula or knife may be sterilized by rinsing with alcohol.

F. Label the cut out section with the 12 o'clock position and label the ends as to the north-south or east-west orientation.

G. Cap the ends of the pipe and wrap the segment entirely with plastic wrap. Plastic wrap will prevent additional oxygen from affecting the internal surface.

H. Ensure the pipe remains uncontaminated from outside sources in the event that additional testing is necessary.

10. Examination of Cut-Out Pipe Segment

- A. Destructive evaluation of the pipe segment may be performed to further verify the extent and cause of internal corrosion after removal.
- B. Cut the pipe lengthwise to allow for internal examination.
 - (1) Cut the pipe in the location of the smallest amount of internal corrosion per the ultrasonic thickness testing.
 - (2) Perform additional ultrasonic thickness testing as necessary.
- C. Clean any remaining material with a dry, stiff brush. A nylon brush is recommended.
 - (1) A metal brush can mar pit features.
 - (2) If all corrosion product is not removed with the stiff brush, use a brass bristle brush in the longitudinal direction only.
- D. Visually examine the area with the unaided eye.
- E. If possible, examine the detail of the corrosion pits using a magnifying lens at 5X to 50X.
 - (1) The following features may be indicative of MIC:
 - (a) Large crater 2-3 inches or more in diameter
 - (b) Cup-type hemispherical pits on the pipe surface or in the craters
 - (c) Striations or contour lines in the pits or craters running parallel to longitudinal pipe axis (around the pipe)
 - (d) This type of corrosion will be seen only under magnification
 - (e) Tunnels sometimes at the end of the craters, running parallel to longitudinal pipe axis (around the pipe)
- F. Identify, measure, and chart all corrosion defects on applicable form. If pitting is found, select the box(es) that most closely describe conditions found. More than one item may be selected. Use space for additional comments if necessary.

11. Documentation

- A. Personnel should complete, **within ClickMobile**, Buried Pipe Examination Form, **CORR 1 Appendix A** and the Corrosion and Steel Damage Evaluation Form, **CORR 1 Appendix B** prior to the [Form GSIC-2.01-1](#).
- B. [Form GSIC-2.01-1](#) is utilized to capture additional information pertinent to internal corrosion. This form is only applicable to storage field gathering system piping carrying dry gas, wet gas or both. This information may be used to update GIS or other databases, as applicable.
- C. The following documentation may also be necessary, depending on tests performed. If used, attach to applicable form:
 - (1) Buried Pipe Examination
 - (2) Corrosion and Steel Damage Evaluation Form
 - (3) [Form GSIC-2.06-1 - Field Analysis for MIC](#)
 - (4) Photographs
- D. Complete a separate form for each location examined.
- E. Print a copy of relevant pictures taken and attach to the form.

UNCONTROLLED IF PRINTED

- (1) For each picture, note what the photo is documenting.
 - (2) Note reference numbers relating to the Coating Defect Table or Corrosion Defect Table.
- F. Document the extent of any repairs or replacements on the applicable form. If repairs or replacements are noted, submit a copy to Supervising Gas Storage Engineer.
- (1) Pipe replacement information may be used to update As-Built drawings as well as the GIS system.
 - (2) Pipe repair information (e.g. sleeves) may be noted in the GIS system.
 - (3) Pipe removal, retirement, or abandonment information may be used to update the GIS system.
 - (4) Maintain documentation in the Project File.

GAS STORAGE INTERNAL CORROSION MONITORING
GSIC 2.02 Monitoring Corrosion Weight Loss Coupons

April 1, 2023

1. General

- A. This procedure describes a standardized method for field handling of corrosion metal coupons prior to and following exposure.
- B. The process of field coupon monitoring is applicable only to the storage field gathering system piping.
- C. Per 49 CFR § 192.477, weight loss coupons must be evaluated two (2) times each calendar year, with intervals not to exceed 7 ½ months. Ameren (AIC) typically installs and removes weight loss coupons at various locations within each storage field coinciding with the injection and withdrawal seasons. Shorter coupon exposures may also be used on a case-by-case basis.
- D. Corrosion monitoring devices should be placed in a location where corrosion is most likely to occur.
- E. Coupons are removed from the coupon holder with clean gloves and stored in envelopes provided by the coupon supplier to prevent contamination which preserves their accuracy.

2. Part 192 Reference

49 CFR §§ 192.475, 192.476, & 192.477

3. Safety Considerations

Refer to [GSIC 1.02](#) - Safety Considerations.

4. Coupon Preparation

- A. Ensure new coupon is the correct size and type.
- B. Always use a new coupon. Never reuse a coupon after exposure and analysis.
- C. Follow the recommended coupon removal dates provided unless otherwise directed by Corrosion Control personnel.
- D. Coupon removal / installation dates should coincide with the beginning and end of injection and withdrawal seasons if possible.

5. Vessel Preparation

- A. Depending on the type of coupon used, the vessel may require depressurization / pressurization for safety.
- B. AIC utilizes the following two types of coupon systems:
 - (1) Plug-type coupons - A plug type coupon is a coupon installed in a fixed pipe plug using a coupon holder
 - (2) Insertion-type coupons - uses a specially designed packing gland to insert or retract a coupon from a pressurized system without a process shutdown.

UNCONTROLLED IF PRINTED

CAUTION: System depressurization is required during insertion and removal when using fixed (pipe plug) coupon holders.

6. Coupon Removal

A. Remove the coupon / coupon holder from the vessel

B. Remove coupon from coupon holder.

(1) Coupons should only be handled on the edges.

(2) Clean, lint-free cotton gloves or cloths, disposable plastic gloves, coated tongs, or coated tweezers are recommended when handling coupons.

C. Inspect the coupon for deposits, damage, and evident corrosion.

D. Place coupon in the coupon's original envelope.

(1) Verify the coupon number is the same as the number on the envelope.

(2) If liquid is present on the coupon, use a clean lint-free paper towel to absorb the liquid before placing it into the envelope.

(3) Ensure coupons that are removed early are held in a clean and dry location until shipped to laboratory with other coupons.

(4) Alternatively, coupons may be removed from the oxygen environment and stored in a non-corrosive alcohol mixture until shipped to laboratory with other coupons.

E. Record the following information on [Form GSIC-2.02-1 - Weight-Loss Coupon Monitoring Report](#), for the appropriate location and coupon serial number:

(1) Storage Field

(2) Well Name/Number

(3) Removal Date

7. Coupon Installation

A. Remove the coupon holder from the vessel.

B. Inspect the coupon holder (plug) threads and vessel for corrosion. Clean and apply new sealant material on both threads.

C. Remove, inspect and clean the assembly. Repair / replace parts if they are damaged, worn or deformed.

D. Attach the new coupon to the coupon holder.

(1) Leave coupons in their protective envelopes or sealed plastic bags until they are being attached.

(2) Clean, lint-free cotton gloves or cloths, disposable plastic gloves, coated tongs, or coated tweezers are recommended when handling coupons.

(3) Ensure coupon(s) is securely held in place and is electrically isolated from contact with all other metals.

(4) Coupons should only be handled on the edges.

Note: If necessary, a notch can be made on the steel plug to ensure appropriate orientation of the coupon in the vessel / pipeline. When coupon is placed in the process flow, it should be parallel to the process flow to reflect similar conditions experienced by the pipeline.

(5) If installing multiple coupons in the same location, ensure coupons are in consistent orientation in order to make the different data sets comparable.

E. Ensure coupon installation location (coupon & coupon holder area) is free of debris prior to reinsertion.

F. Screw the fixed coupon holder back into the vessel. If a notch was made, verify the notch is in the position specified to ensure coupon is oriented correctly.

G. Pressurize the vessel, if necessary.

H. Record the following information on [Form GSIC-2.02-1 - Weight-Loss Coupon Monitoring Report](#):

(1) Storage Field

(2) Well Name/Number

(3) New Coupon Serial Number

(4) Initial Coupon (New) Weight

(5) Installation Date

I. Store empty coupon envelopes in a clean and dry place until coupons are removed.

8. Submit to Laboratory

A. Package coupons for shipment to laboratory.

(1) Ensure coupon envelopes are properly sealed.

(2) Sort and package coupons by storage field.

B. Fill out any laboratory request forms, if necessary

C. Request laboratory analysis for the following characteristics:

(1) Final Coupon Weight

(2) Weight Loss

(3) Corrosion rate (mils per year)

(4) Corrosion deposits

(5) Type of Corrosion (i.e. local, general, pitting)

D. The laboratory will need the following information in order to complete its analysis. This data should be available on [Form GSIC-2.02-1- Weight-Loss Coupon Monitoring Report](#):

(1) Initial Coupon Weight (pre-recorded based on coupon Serial Number)

(2) Exposure Time (Date installed / removed)

E. Mail or ship coupons to the laboratory using a traceable method.

9. Documentation

UNCONTROLLED IF PRINTED

- A. Includes [Form GSIC-2.02-1 - Weight-Loss Coupon Monitoring Report](#).
- B. Maintain documentation in the project file
- C. Coupon changeout dates will be entered into Maximo by qualified storage field personnel.

GAS STORAGE INTERNAL CORROSION MONITORING GSIC 2.03 Collecting and Testing of Fluid Samples

April 1, 2023

1. General

A. This process establishes a standardized method for the collection and/or analysis of interior pipeline or vessel fluid samples.

B. The process of field testing fluid samples is applicable to pipelines carrying wet gas. Internal corrosion control for pipelines outside of the storage fields is covered in [CORR 1. Ameren Illinois' \(AIC\) Operation and Maintenance \(O&M\) Plan](#).

C. Fluids existing on the interior of pipeline systems provide environments conducive to corrosion. Liquid measurements can be used to predict changes in corrosivity arising from changes in process conditions.

2. Part 192 Reference

49 CFR §§ 192.475, 192.476

3. Safety Considerations

Refer to [GSIC 1.02](#) - Safety Considerations. Wear eye protection and gloves as prescribed below.

4. Sample Equipment Description

A. Sample equipment consists of

(1) Plastic Gloves

(2) Eye Protection

(3) New plastic bottle(s) with label marked to identify chemical treatment type, if any. Plastic bottles may contain treatment chemical (preservative), identified as part of the bottle label

(4) Optional - One wide mouth plastic container to collect sample and decant into 4 oz plastic bottles.

(5) For pig runs a large bucket may be used.

5. Annual Liquid Sampling Location Selection

A. Obtain liquid samples at a location most representative of the system.

(1) Approval to perform the sampling and selection of the location should always be obtained from the responsible person.

(2) Consider flow dynamics and how they will influence the sample.

B. Sample at locations such as drips, low area flows, separators, etc.

C. Samples may be obtained from either pipeline (flowing) or storage tank (static) systems.

D. Pipeline fluids can contain suspended solids, which are particles distributed throughout the fluid. These particles tend to make the fluid cloudy when thoroughly mixed. In static fluids, particles will settle out when they have sufficient size and density.

UNCONTROLLED IF PRINTED

E. Sources for field water testing kits include:

- (1) **ChampionX**
- (2) **PDC Laboratories**
- (3) Chemetrics
- (4) Hach Company
- (5) LaMotte Company
- (6) MSES Consultant

6. Testing Process

A. Wear clean latex gloves (or equivalent) when obtaining sample.

B. Wear suitable eye protection

C. Collecting Sample

(1) If the sample source valve provides adequate control to directly decant the fluid directly into the plastic bottle

(a) Place the neck of the bottle at the bottom of the sample source valve.

(b) Open the sample source valve and flow liquid into the bottle, allowing the fluid to eventually reach the neck of the bottle and overflow.

(2) If the sample source valve only provides adequate control to decant the fluid into the wide mouth sample container

(a) Place the wide mouth sample container at the outlet of the sample source valve

(b) Slowly open the sample source valve and fill the wide mouth sample container

(c) Decant the fluid from the wide mouth sample container into the bottle. If multiple bottles are needed to complete the sample they may be decanted from one fill of the wide mouth sample container

D. Completely fill each plastic bottle with the liquid/water sample. The bottle should be full to displace air.

(1) Sufficient volume of fluid may be required to flow in order to displace the dead volume and provide a better representative sample.

(2) Annual internal corrosion monitoring typically requires three (3) plastic bottles, provided by the laboratory, as follows:

(a) **One** bottle, no preservative: Used to sample for Chlorides, Sulfates, Alkalinity (Total As CaCO_3), Silicon

(b) **One** bottle, Zinc Acetate or Sodium Hydroxide treatment: Used to sample for Sulfide

(c) **One** bottle, Nitric Acid **or equivalent** treatment: Used to sample for Magnesium, Barium, Iron, Manganese, Calcium, Sodium, Potassium

(3) Additional sample bottles may be required to evaluate chemical treatment residuals.

(4) For testing that requires preservatives, follow the laboratory instructions for obtaining the sample.

(5) Smaller samples may be used if only performing specific tests. Likewise, if a full sample size is not available, the number of tests may be limited in order to optimize the type and quantity of results obtained.

(6) Priority should be given to pH, temperature, and bacteria tests.

E. Perform pH field test immediately and document the result as exposure to the outside environment can rapidly affect pH values. If an electronic pH meter will be used, calibrate per manufacturer instructions.

F. If requested by Corrosion Control personnel, perform carbon dioxide (CO₂), hydrogen sulfide (H₂S) and alkalinity field tests immediately and document results as exposure to the outside environment can rapidly affect these parameters.

(1) Field testing should be done within four (4) hours of collection.

(2) Field testing requires purchasing a specific test kit. Examples include:

(3) MSES Consultants, Inc. - CO₂ (SKU 5001 or 5002); Sulfide (SKU 5003); Alkalinity (SKU 5004)

(4) HACH Company - CO₂ (Model CA-23 or CA-DT); H₂S (Model HS-WR or HS-C); Alkalinity (Model AL-DT, AL-TA or AL-AP)

G. If multiple samples are taken, record the following information on Form GSIC-2.03-1 or other similar form during sampling:

(1) Date and location of the sample

(2) Sample pH

(3) Color of the sample. Use clear, brown, black, gray, etc.

(4) Sample temperature

(5) The amount of suspended matter. Use none, small, moderate and severe

(6) Identify any odor (specifically hydrogen sulfide) and the presence of slime or deposits in the water sample.

H. Perform testing to determine the presence of microbiological bacteria (SRB and APB) per [GSIC 2.06](#) - Field Testing for Bacteria (MIC).

(1) Obtain the test liquid from a bottle that does not contain any reactant or substance (preservative).

(2) Tightly close and label the bottles with the following information:

(a) Location and/or Line name

(b) Sample number (including date)

Example of sample numbering format as follows:

XX-MMDDYY-ZZ

where,

XX = 2-letter code for storage field

MMDDYY = month, date, year

ZZ = 2-digit sequential number

Example: The first sample taken on July 16, 2009 at Johnston City storage field would be labeled **JC-071609-01**.

(3) If multiple samples are taken at the same location, it is recommended to enclose the bottles in a 1 gallon plastic bag and label the bag with the Sample Identification and Location matching the individual bottles.

I. Deliver the samples to the laboratory as soon as possible.

(1) Analysis should be performed by a qualified laboratory.

(2) If possible, samples taken for laboratory analysis should be transported in an insulated container with minimum agitation.

(a) If possible, samples should be tested within 36 hours of collection.

(b) Depending on ambient conditions a refrigerated container may be used. Annual sampling for internal corrosion is typically performed during winter months where additional refrigeration is not necessary.

(3) National Environmental Laboratory Accreditation Program (NELAP) accreditation is recommended however a preferred laboratory with industry certification may be used at the discretion of the Corrosion Control personnel.

7. Documentation

A. Maintain all documentation and laboratory results in the following Project File:

(1) Routine / Regular Maintenance

(2) Facility (Storage Field)

(a) Well

(b) Segment

GAS STORAGE INTERNAL CORROSION MONITORING
 GSIC 2.04 Sampling Natural Gas for Laboratory Analysis

April 1, 2023

1. General

A. This procedure describes a standardized method for obtaining high pressure natural gas samples for subsequent analysis by gas chromatography.

B. Gas sampling is focused in "spot" samples of natural gas from storage field pressure sources in containers which are suitable for transporting the sample to a laboratory.

C. This procedure is suitable for sampling "wet" gas and/or "dry" gas. There is a pressure restriction for "wet" gas set at 1100 psi.^[1]

D. Several components in natural gas can affect the internal corrosion of pipelines. Knowledge of gas quality aids the corrosion engineer in determining the potential impact these components might have on the integrity of a system.

2. Part 192 Reference

49 CFR §§ 192.475, 192.476

3. Safety Considerations

Refer to [GSIC 1.02](#) - Safety Considerations. Observe guideline precautions for venting natural gas with potential H₂S concentrations.

4. Field Tests

The "Purging Fill and Empty" method for collecting natural gas samples is preferred.

5. Cylinder Preparation & Transport

A. Use only stainless steel gas sample cylinders, valves, stainless steel tubing, and fittings suitable for the safe handling of the high gas pressures involved.

(1) Standard fittings are: ¼-inch NPT fittings, ¼-inch stainless steel tubing, and the ¼-inch compression fittings.

(2) Do not use copper, high pressure polypropylene, or Nylon tubing.

(3) The following table lists gas sampling equipment and fittings acceptable for pressures up to 1800 psig. For operating pressures greater than 1800 psig special sampling cylinders must be used.

Item ID	Item	Description	Part Number
1	Gas Sample Cylinder	Stainless Steel Double Ended Cylinder, ¼" FNPT, 500cc, 1800 psig	Swagelok® 316L-HDF4-500
2	Valve, Needle	Stainless Steel Non-Rotating Stem Valve, ¼" MNPT - ¼" FNPT	Swagelok® SS-16DKM4-F4
3	Valve, Needle	Stainless Steel Non-Rotating Stem Valve, ¼" MNPT - ¼"MNPT With Rupture Disc	Swagelok® SS-16DKM4F4-2

UNCONTROLLED IF PRINTED

4	Valve, Ball Shut-Off	Stainless Steel, 1-Piece Ball Valve, 1/4", FNPT	Swagelok® SS-43GEF4
5	Tee	Stainless Steel Tee, 1/4", FNPT	Swagelok® SS-4-T
6	Nipple	Stainless Steel Hex Long Nipple, 1/4" MNPT, 2" Length	Swagelok® SS-4-HLN-2.00
7	Tubing	316L Seamless Stainless Steel Tubing, 1/4"OD x 0.035" Wall	Swagelok® SS-T4-S-035
8	Connector	Stainless Steel Female Connector, 1/4" OD - 1/4" FNPT	Swagelok® SS-400-7-4
9	Connector	Stainless Steel Male Connector, 1/4" OD - 1/4" MNPT	Swagelok® SS-400-1-4
Not Shown	Plug	Stainless Steel Pipe Plug, 1/4" MNPT	Swagelok® SS-400-P
Not Shown	Cap	Stainless Steel Pipe Cap, 1/4" FNPT	Swagelok® SS-400-C
10	Metal flexible hose	PTFE-Lined, Stainless Steel Braided Hose	Swagelok® SS-TH6TA4TA4-28

(4) Components from other manufacturers/suppliers that meet or exceed the same specifications are acceptable.

(5) If tests for hydrogen sulfide and other sulfur compounds will be performed, special sample cylinders lined with Teflon® must be used because sulfur-containing compounds react with stainless steel surfaces.

(6) Contact the Corrosion Control personnel to determine whether sampling for hydrogen sulfide and sulfur compounds is required.

(7) Contact the appropriate Storage Field Operations personnel with questions regarding sampling equipment compatibility.

B. Ensure that test sample cylinders have been tested according to U.S. DOT requirements.

(1) The cylinder provider will test the cylinders annually according to US DOT Requirements and maintain documentation of the following:

- (a) Test (inspection) date
- (b) Conditions and results of the pressure test
- (c) Cylinder provider's signature

C. Natural gas carries a hazardous substance designation. Filled sample cylinders require special labeling, packaging, handling, and must be accompanied by supporting transmittal documentation when being shipped/transported to a laboratory.

(1) The proper shipping designation for sample cylinders containing natural gas as a hazardous substance is: "Natural Gas, Compressed, 2.1, UN1971, II".

(2) Shipping requirements for filled natural gas sample cylinders can vary from region to region. Consult with the carrier prior to sampling regarding specific packaging and documentation requirements

(3) Transport filled natural gas sample cylinder(s) from sampling site to the laboratory using foam filled cases labeled with the appropriate NFPA 704 system information.

(4) Chain of custody forms are provided by cylinder provider and should be completed once all samples have been collected at the specific storage field.

UNCONTROLLED IF PRINTED

D. The use of IsoTubes can be applied to collect a gas sample when H₂S levels are below 5 ppmv.

(1) A Wellhead sampler is needed for the IsoTubes to be properly utilized when collecting a gas sample.

(2) IsoTubes are intended for a one-time use.

6. Sampling Guidelines

A. Obtain gas samples at a location most representative of the system. Gas samples should be taken upstream of any treatment equipment or device that would alter the characteristics of the gas.

B. Collect samples on the upstream side of gas metering or points of pressure drop to avoid any condensation.

C. Collect samples from a source at or near the top center of the pipe (vessel). Side stream samples are acceptable where access is limited.

7. Purging - Fill and Empty Method

A. For sampling of a known dry gas stream, proceed to install a sampling line and bleeding valve according to the following figure. Gas streams suspected of having entrained liquids at the time of sampling require the use of a gas sampling separator. This guideline does not address such situations.

B. The sampling setup includes the following components:

(1) Source Valve

(2) Bleeding Valve (Valve A)

(3) Sample Line (i.e. metal flexible hose)

(4) Gas Sample Cylinder

(5) Gas Sample Cylinder Valves (Valves B & C)

(6) Sampling Control Valve (Valve D)

(7) Extension Tubing

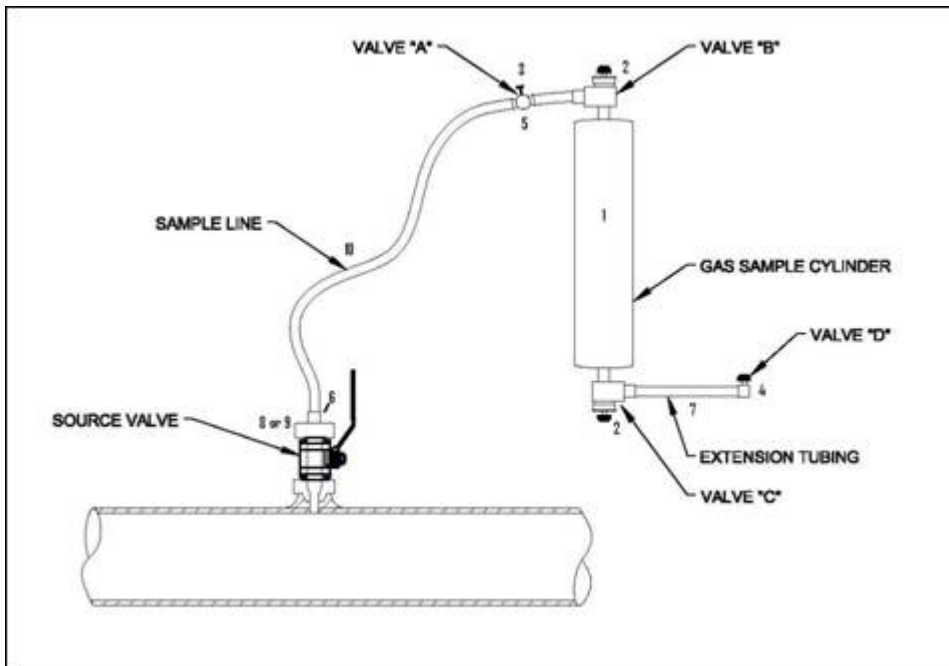

Figure 1. Diagram of the Setup for Gas Sampling

C. Set-Up

- (1) Open and close the source valve to clear any debris from the valve before making any connections.
- (2) Wrap all NPT fitting connections with two wraps of Teflon[®] tape (or equivalent) to seal and protect the threads.
- (3) Connect the Sample Line (metal flexible hose) equipped with a bleeding valve (Valve A) to the Source Valve.
- (4) Keep the Sample Line length to a minimum.
- (5) If the atmospheric temperature is significantly below the gas temperature, warming the Sample Line may help prevent condensation. Do not use an open flame.
- (6) Ensure that Valves B and C are fully closed.
- (7) Install valves with their flow indicator arrows directed away from the cylinder.
- (8) Remove the caps from the compression fittings on the Gas Sample Cylinder valves. (Valves B and C)
- (9) Connect the opposite end of the Sample Line to Valve B on the Gas Sample Cylinder inlet.
- (10) Attach Extension Tubing to Valve C.
- (11) This tubing should be at least 18" long to prevent Joule-Thompson cooling from influencing the condition of the gas filling the cylinder.
- (12) Connect the opposite end of the Extension Tubing to Valve D (sampling control valve).

WARNING: Ensure that the Sampling Control Valve (Valve D) discharge vents natural gas away from the person(s) collecting the sample due to high pressure.

D. Purging

- (1) Orient the Gas Sample Cylinder in a vertical position. Refer to the figure above.
- (2) Support the cylinder to prevent stress on the fittings and tubing.
- (3) With Valves A, B, C and D closed, carefully open the Source Valve to the fully open position.
- (4) Slightly open Valve A to remove any residual air until the flexible sampling line is purged.
- (5) Close Valve A.
- (6) Open Valve B. When a partial vacuum exists, one can hear the natural gas moving into the cylinder.
- (7) When the movement has stopped, open Valve C.
- (8) Check all connections up to Valve D using a dilute soap solution (e.g. Snoop[®]).
- (9) Tighten fittings that are leaking.
- (10) Slightly open Valve D to remove any residual air until the entire sampling system is purged.
- (11) Close Valve D.
- (12) Close Valve B.
- (13) Open Valve D and slowly vent the Gas Sample Cylinder to just above atmospheric pressure.
- (14) Close Valve D.
- (15) Open Valve B to refill the Gas Sample Cylinder.
- (16) Repeat Step (12) through (15) a total of four (4) times.

E. Gas Sample Collection

- (1) When the purging process is complete and Gas Sample Cylinder is at full pressure, close Valve C.
- (2) Close Valve B.
- (3) Record the gas pressure, gas temperature and time on [Form GSIC-2.04-1](#), Field Gas Sampling.
- (4) Carefully open Valve D to vent the Extension Tubing.

F. H₂S Testing

- (1) Connect 1/4" plastic tubing to Valve A (bleeding valve).
- (2) Test for H₂S content per procedure "[Field Testing Natural Gas for Hydrogen Sulfide](#)".
- (3) Close Valve A after H₂S testing.
- (4) Disconnect plastic tubing from Valve A.
- (5) Close Source Valve.

G. Securing the Gas Sample

- (1) Open Valve A to vent the segment (sampling line)
- (2) Disconnect the tubing from Valves B and C.

UNCONTROLLED IF PRINTED

- (3) Disconnect the tubing from Source Valve.
- (4) Check for leaks using a dilute detergent solution at the threads and around the stems on Valves B and C (Gas Sample Cylinder).
- (5) Install plugs or caps on the open ends of the valves on the Gas Sample Cylinder to protect the threads.
- (6) Tag each cylinder with the following information:
 - (a) Name of Company Submitting Sample for Analysis
 - (b) Sample Identification (ID)
 - (c) Gas Temperature and Pressure
 - (d) Date and Time of Sample Collection
 - (e) Sampling location
 - (f) H₂S reading

H. Collection of Natural Gas Sample with use of IsoTube

- (1) Locate a suitable, vertical port for collecting a sample. A suitable port will supply a dry, liquid free gas sample and should consist of both a 1/4" female NPT port, and a control valve that can be used to turn the gas on and off.
- (2) Make sure that the threads on the Wellhead Sampler are clean and wrap 2 or 3 layers of Teflon[®] tape, clockwise onto the male threads of the filter.
- (3) Screw the Wellhead Sampler into the sampling port and then tighten by using a wrench on the body of the filter
- (4) With the Wellhead Sampler valve in the "shut" position, slowly open the control valve on the sampling port. Line pressure will be indicated on the inlet pressure gauge.
- (5) Insert the bottom IsoTube[®] valve into the Wellhead Sampler by simply pushing it firmly into the chuck (there are cogs in the chuck which grip the threads on the IsoTube[®] valve and hold it in place). To further tighten the IsoTube[®] in place, lightly rotate it with your fingers, screwing it into the chuck.
- (6) Turn the handle on the 3-way valve to the "open" position (vertical). The IsoTube[®] will fill with gas. Note the pressure on the outlet gauge. The pressure should be less than 80 psig.
- (7) With the 3-way valve still in "open" position, the Wellhead Sampler and the IsoTube[®] can be purged by depressing the spring valve in the tip of the top IsoTube[®] valve (like letting the air out of a tire). Hold the spring valve open for a few seconds. This shortcut should be minimized if you are sampling very wet gases or under very cold conditions as it can result in condensing liquids in the IsoTube[®].
- (8) Final purging and filling of the IsoTube[®] is accomplished by rotating the handle on the 3-way valve "open" and "shut" to alternately pressurize and vent the IsoTube[®].
- (9) The IsoTube[®] should be filled to the output pressure of the regulator and then vented to atmospheric pressure by watching the outlet pressure gauge and listening to the flow of gas out the vent. The more times this process is repeated, the less the chance of atmospheric contamination of the sample. A minimum of 10 cycles is recommended.
- (10) After the IsoTube[®] is filled for the last time, leave the 3-way valve in the "open" position.
- (11) The IsoTube[®] may now be removed from the chuck by sliding the knurled sleeve on the outside of the chuck down, away from the IsoTube[®]. This process should be done quickly so as to minimize

UNCONTROLLED IF PRINTED

the amount of gas lost. If the IsoTube® is held very lightly, it will generally pop up out of the chuck from the spring action of the valve and the gas pressure. Be ready to catch it.

(12) Replace the end caps on the IsoTube® valves and fill out one of the adhesive-backed labels with the sample identification information using the ball point pen provided (press hard as three copies are made). Attach the label to the IsoTube® in the location marked and return the IsoTube® to the shipping carton. When an entire sheet of sample tags has been used, one of the copies should be placed in the box with the IsoTubes® and the other can be retained for your records

(13) Seal the box, attach the appropriate hazardous material labels, and ship the samples as described on the enclosed shipping instructions.

NOTE:	Hazardous materials can only be shipped by someone properly certified to do so; shipping instructions are included with each box of IsoTubes® merely to simplify the shipping process.
--------------	--

where

8. Laboratory Analysis

A. Routine analysis should include, but not be limited to, the following:

Component	Units
Nitrogen (N2)	Mole Percent
Carbon Dioxide (CO2)	Mole Percent
Oxygen (O2)	Parts Per Million
Methane (C1)	Mole Percent
Ethane (C2)	Mole Percent
Propane (C3)	Mole Percent
Isobutane (iC4)	Mole Percent
Normal Butane (nC4)	Mole Percent
Isopentane (iC5)	Mole Percent
Normal Pentane (nC5)	Mole Percent
Hexanes Plus (C6+)	Mole Percent
Other Sulfur Species	Parts Per Million
Relative density	N/A
Heating Value (dry)	Btu/Scf
Heating Value (sat)	Btu/Scf

B. For gases, mole percent value is equivalent to volume percent.

C. Tests for other sulfur species not typically included in a routine analysis are available by special request.

D. Tests for hydrogen sulfide and other sulfur compounds are not typically included in a routine analysis but are available by special request. These are recommended for storage fields with historically high hydrogen sulfide levels.

9. On-Site Chromatographs

If a chromatograph exists on-site, the normalized component data of only injection gas from such equipment can be used in lieu of sampling.

10. Documentation

A. Document the following for each sample:

- (1) Sample Identification
- (2) Cylinder Identification
- (3) Sample Source/Description
- (4) Date and Time of Sample Collection
- (5) Gas Temperature and Pressure
- (6) Notation of Any Prevailing Issues Pertaining to the Sampling Process
- (7) H₂S reading

B. Complete [Form GSIC-2.04-1 - Field Gas Sampling](#).

C. If required, complete Chain of Custody Record and Request and provide to the laboratory.

GAS STORAGE INTERNAL CORROSION MONITORING
GSIC 2.05 Field Testing Natural Gas for Hydrogen Sulfide

January 1, 2013

1. General

A. This procedure describes a standardized method for determining the amount of Hydrogen Sulfide (H₂S) in the gas using an H₂S stain tube or an electrochemical sensor during the following: routine sampling (i.e. annually, weekly, daily), spot sampling, validation of sampling equipment.

B. This procedure applies to field testing for H₂S in storage field gathering system piping carrying dry gas, wet gas or both. Internal corrosion control for pipelines outside of the storage fields is covered in [CORR 1](#). Ameren Illinois' Operation and Maintenance (O&M) Plan.

C. The determination of H₂S concentrations in gas is important due to the corrosive nature of H₂S on pipeline and vessel materials. This process provides practical field determination of hydrogen sulfide concentration.

2. Part 192 Reference

49 CFR §§ 192.475, 192.476

3. Safety Considerations

Please refer to [GSIC 1.02](#) - Safety Considerations. Observe guideline precautions for venting natural gas with potential H₂S concentrations.

4. Test Setup

A. Obtain gas samples at representative locations such as the following:

- (1) Wellhead piping upstream of any gas treatment equipment
- (2) Sulfa-treat towers
- (3) Station piping

B. Approval to perform the sampling and selection of the location should always be obtained from the responsible storage field personnel.

C. Consider the flow dynamics and how they will influence the sample. For example, the sample may be influenced by the well status (i.e. active, shut-in or no flow down hole pressure monitor).

D. Collect samples on the upstream side of gas metering or pressure drop points to avoid any condensation.

E. Collect samples from a controlled source such as a small valve at or near the top center of the pipe (vessel). Side stream samples are acceptable where access is limited.

F. Open the controlled source briefly to clear residual debris and moisture.

G. Setup one of the following Sampling Chambers in order to test for H₂S.

- (1) Plastic Bag with holes to relieve pressure
- (2) Plastic Connecting Tube with a plastic tee
- (3) Jacobs Mixing Chamber (i.e. bottle with holes)

UNCONTROLLED IF PRINTED

H. If using a connecting tube, use sufficient length to carry the natural gas a safe distance during the sampling process.

I. Connect Sampling Chamber (see figures below) as follows:

- (1) Plastic Bag - Tie the bag around the Source Valve.
- (2) Connecting Tube - Attach one end of the tube to the Source Valve.
- (3) Jacobs Mixing Chamber - Screw the threaded end onto the Source Valve. (Recommended)

J. Example of Testing Configuration

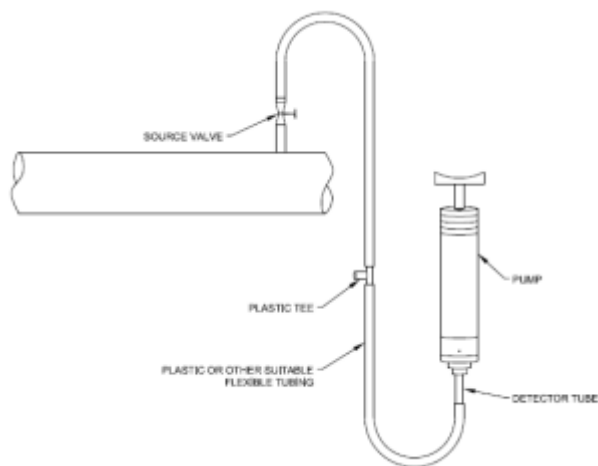

OR

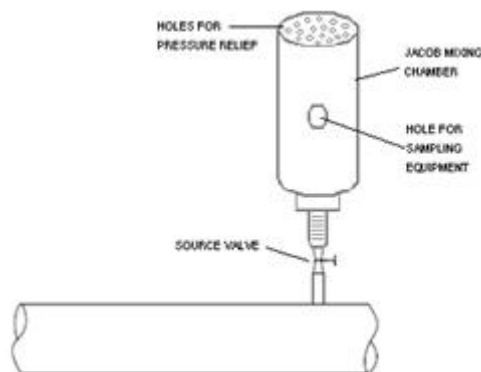

K. Select a Length-of-Stain Detector Tube for the component being tested.

L. Use a stain tube suited for the expected concentration range.

5. Sample Equipment Preparation

A. H₂S Stain Tubes

- (1) Use a hand operated pump capable of drawing a minimum of 100 ml sample per stroke through the stain tube with an accuracy of ± 2 ml.

UNCONTROLLED IF PRINTED

- (2) Ensure the pump is designed for use with stain tubes.
- (3) Ensure stain tubes fit the pump being used.
- (4) Verify the stain tubes have not expired. Expiration dates are typically marked on the manufacturer's box.
- (5) Ensure that sampling lines are not made of material that reacts with or absorbs H₂S such as:
 - (a) TFE-fluorocarbon
 - (b) Vinyl
 - (c) Polyethylene
 - (d) Stainless steel
- (6) Tygon SE-200 3/8 Inch OD by 1/4 Inch ID tubing and nylon or Polyvinylidene fluoride (PVDF) tee for 1/4 Inch ID tubing is an acceptable alternative.
- (7) Perform a pump field leakage test prior to use. The pump need not be tested more than once per day.
- (8) Insert an unbroken stain tube into the Gas Pump connector to plug the pump inlet.
- (9) Stroke the pump (one stroke) and wait thirty (30) seconds.
 - (a) No loss of vacuum (diaphragm travel) indicates a successful test.
 - (b) If the check fails, confirm that the connection between the connector on the pump and stain tube is tight and try again.
 - (c) If the stain tube is intact but vacuum is not maintained, the pump is leaking and another pump should be used.

B. H₂S Electrochemical Sensor

- (1) Calibrate gas meter according to manufacturing instructions prior to use.
- (2) Follow the manufacturer's directions for calibration.
- (3) Need not be calibrated more than once per day.

6. Testing Process

A. Record the gas temperature and source pressure. Gas temperature should be between 32°F to 100°F.

B. Connect (insert) the sample tubing to the controlled source.

C. H₂S Stain Tubes

- (1) Carefully break the tips at both ends of the Length-of-Stain Detector Tube. Scoring the tips helps ensure a clean break.
- (2) Insert the outlet end into the Gas Pump Connector (arrow on stain tube must point toward the pump).
- (3) Reset the counter on pump to read zero (0), if necessary.
- (4) Insert the other end of the stain tube into the connecting tubing attached to source.

UNCONTROLLED IF PRINTED

(5) Slowly open source valve to obtain a gradual flow through the connecting tubing and tube access point.

CAUTION: Do not over-pressurize the gas sampling line.

(6) Stroke the Gas Pump, drawing the required measured volume of gas through the Length-of-Stain Detector Tube. (On most pumps, one full stroke is considered to be 100 ml.)

(7) Perform 1 to 10 strokes, not to exceed the stroke (n) value specified on the desired scale on the stain tube.

(a) If the stain extends beyond the end of the scale, repeat sampling using a Length-of-Stain Detector Tube with a higher concentration range or use partial stroke.

(b) After the initial stroke, if the stain extends beyond the first line, that concentration can be used. If the stain does not extend beyond the first line, additional strokes are required.

(c) Keep track of the number of strokes taken.

Note: Samples with higher H₂S concentrations may only require partial pump strokes. Multiple pump strokes may be needed at lower concentrations.

(8) Read concentration listed on the calibration scale at the interface of the stained-to-unstained reagent (see diagram) within 2 minutes after testing.

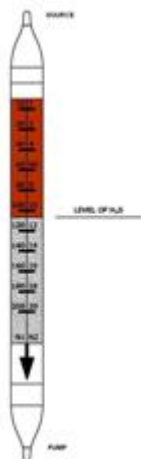

(9) Calculate the concentration of H₂S using the following equation. For calculation use n=10.

$$\text{ppm H}_2\text{S} = \frac{\text{No. of strokes on stain tube}}{n} \times \text{concentration on calibration scale}$$

D. H₂S Electrochemical Sensor

(1) Place sensor in sampling chamber.

(2) Use according to manufacturer's instructions.

7. Documentation

A. Complete Form [GSIC-2.05-1 - Annual On-Site H₂S Readings](#), when performing annual testing.

UNCONTROLLED IF PRINTED

- (1) Record weekly/daily H₂S results on field specific spreadsheet.
- (2) Document the following for each sample:
 - (a) Testing source / description
 - (b) Date
 - (c) Gas temperature and pressure
 - (d) Number of pump strokes
 - (e) Stain tube reading
 - (f) Concentration(s) of H₂S tested as calculated
 - (g) Document any issues that occurred during the sampling process
- (3) Maintain documentation in the project file.

GAS STORAGE INTERNAL CORROSION MONITORING
 GSIC 2.06 Field Testing for Bacteria MIC

January 1, 2013

1. General

- A. This process establishes a standardized method for the collection and analysis of interior pipeline fluid samples for the presence of bacteria known to influence corrosion. Aspects of both sessile and planktonic forms of bacteria are covered.
- B. This procedure is intended for estimating the planktonic bacterial population present in natural gas and liquid piping systems. It is not intended to evaluate other types of organisms.
- C. This process encompasses a technique known as serial dilution. This approach provides qualitative and semi-quantitative means for determining the existence and relative magnitude of the particular bacteria of interest.
- D. Certain microbes (bacteria) have the potential to impact or influence the internal corrosion of pipelines. These microbes represent primarily two anaerobic types, the acid-producing bacteria (APB) and sulfate-reducing bacteria (SRB).
- E. As anaerobes, they are extremely intolerant of air (oxygen). Bacteria in a "free-floating" state are known as planktonic bacteria and can only be determined from fluid samples. To identify their presence, they must be cultured immediately upon sample collection to prevent any exposure to air.
- F. Microbe culture media consist of bottles containing a nutrient under anaerobic conditions where the bacteria can thrive and reproduce during a certain incubation period. The culture media contain specific indicators which respond upon the presence and reproduction of the APB and SRB-types.

2. Part 192 Reference

49 CFR §§ 192.475, 192.476

3. Safety Considerations

- A. This procedure entails the use of syringes and needles. All syringes shall be destroyed following use. Failure to do so is unlawful pursuant to Federal regulations.
- B. After use, syringes should be deposited in a Sharps Container. If a Sharps container is not available, the plunger is removed from the syringe, needles are cut/broken and the syringe barrels crushed prior to disposal.
- C. Refer to [GSIC 1.02](#) - Safety Considerations.

4. Bacteria Culture Vial Preparation

- A. Use only clean, new containers for sampling collection.
- B. Never rinse the container prior to use.
- C. Table A lists equipment that may be necessary to collect liquid, solid and/or surface wipe samples in the field.

Table A. Sampling Equipment
Description

Item	Description
Bacteria Culture Vials - SRB	Modified Postgate Media B Vials

UNCONTROLLED IF PRINTED

Bacteria Culture Vials - APB
Culture Bottle with Cap
Bottle, Glass
Syringes, Disposable
Container for Syringe Disposal
Tongue Depressors
Cotton Swabs
Alcohol Pads
Marking Pen, Permanent
Gloves

Anaerobic Acid Producing Vials
Anaerobic Diluent Solution (ADS)
Bottle, Clear Glass, 500 ml.
Syringe with Needle, Slip Tip, 3 ml.
Sharps Container, 1 gal.
Tongue Depressor, Sterile, 6"L x 3/4"W
Cotton Swab, Sterile
Alcohol Pads, Sterile
Example: Sharpie Pen
Latex or non-latex

D. Preparation of Serial Dilution Vials

- (1) Verify the vials are within their usable shelf-life.
- (2) The media within the vials have a shelf-life of six months subsequent to formulation.
- (3) Expiration dates are typically marked on the shipping container.
- (4) Discard vials existing beyond this date and do not use for testing.
- (5) Internal corrosion monitoring typically requires two types of Bacteria Culture Vials:
- (6) Anaerobic Sulfate Reducing Bacteria (SRB)
- (7) Anaerobic Acid Producing Bacteria (APB)
- (8) Sample sets may be purchased as a pre-packaged kit. Examples include:
- (9) MSES Consultants, Inc. - SKU 510, 520 or 530
- (10) Dixie Testing and Products, Inc. - Test Kit Number 4
- (11) Alternatively, individual bacteria culture vials may be assembled into sets of five (5) vials^[1]
- (12) Number the vials 1 through 5 in each set.
- (13) If duplicate sampling of a particular source is warranted, prepare a second set of Bacteria Culture Vials in the same manner and identify with the same sample number.

5. Testing Guidelines

A. Obtain liquid samples at a location most representative of the system.

- (1) Approval to perform the sampling and selection of the location should always be obtained from the responsible person.
- (2) Consider the flow dynamics and how they will influence the sample.
- (3) For example, a sample will be influenced by well status (i.e., shut-in or active).

B. Sample at locations such as drips, low area flows, separators, etc.

C. Samples may be obtained from either pipeline (flowing) or storage tank (static) systems.

D. Pipeline fluids can contain suspended solids which are particles that are distributed throughout the fluid and tend to make the fluid cloudy when thoroughly mixed.

- (1) Solids can be separated from the fluid with filtration.
- (2) In static fluids, particles will settle out when they have sufficient size and density.

E. Sufficient volume of fluid may be required to flow in order to displace the dead volume and provide a better representative sample.

F. To maintain sample integrity, it is essential that samples have minimal exposure to the atmosphere.

6. Field Testing Process

A. Ensure gloves are worn once sampling begins.

B. Remove a sterile 3 mL syringe from the paper packet leaving the needle cover in place.

C. Prepare the initial Bacteria Culture Vial(s) from each set described in section 4. D. (7) and 4. D. (8) above.

(1) Remove the metal tab from the top of the vial labeled #1 within each set of vials with a clean tool.

(2) Do not remove the metal septum retainer in the process of removing the tab.

(3) Wipe the top of vial/septum with a clean alcohol pad.

D. Record the sample information on form provided in the test kit or on [Form GSIC-2.06-1 - Field Analysis for MIC](#).

(1) Label the bacteria kit with the following information:

(a) Location and/or Line name or Wellhead name

(b) Sample number (including date)

(2) Sampling numbering format

Example of sample numbering format as follows:

XX-MMDDYY-ZZ

where,

XX = 2-letter code for storage field

MMDDYY = month, date, year

ZZ = 2-digit sequential number

Example: The first sample taken on July 16, 2009 at Johnston City storage field would be labeled **JC-071609-01**.

(3) Bacteria testing performed as part of the annual liquid sampling process will include the wellhead name rather than a sequential number.

E. Liquid Samples (Planktonic Bacteria)

(1) Obtain a sample according to Gas Storage Internal Corrosion Monitoring [GSIC 2.03](#) - Collecting and Testing of Fluid Samples.

(2) Test a sample from a bottle that does not contain any reactant or preservative.

(3) The liquid sample may be tested directly into the first bacteria culture vial. Refer to section 6. G through 6. N for inoculating the vials.

UNCONTROLLED IF PRINTED

F. Solid Samples (Sessile Bacteria)

- (1) Obtain a sample according to [GSIC 2.01](#) - Internal Corrosion Examination.
- (2) Collect one-half (½) teaspoon of solid material.
- (3) If biofilm or soft corrosion product is being tested, swab the area (1 in.2) using a sterile cotton swab wetted with Anaerobic Diluting Solution (ADS).
- (4) Add solid material to ADS tube.
- (5) If a cotton swab was used, break the tip off into the ADS.
- (6) Shake the ADS tube well to disperse any solids and microorganisms.
- (7) The ADS liquid will then be tested in the bacteria culture vials.

G. Withdraw approximately 3 mL of sample into the syringe. Avoid the introducing any air bubbles into the syringe.

H. Tap the barrel of the syringe, turn the syringe/needle upward and discharge all but 1 mL of sample. This will eliminate any gas bubbles that are present.

I. Insert the needle through the septum of Vial #1 and discharge the remaining 1 mL sample into the vial.

J. Thoroughly shake the vial to mix the sample with the test media.

K. An immediate color change from clear to black on an SRB test may indicate sample contamination. Repeat the test with a new syringe/needle and vial set.

L. If occurs again, SRB concentrations may be high.

M. Remove the needle/syringe from the bottle and dispose of the syringe into a Sharps container, if available. See figure below.

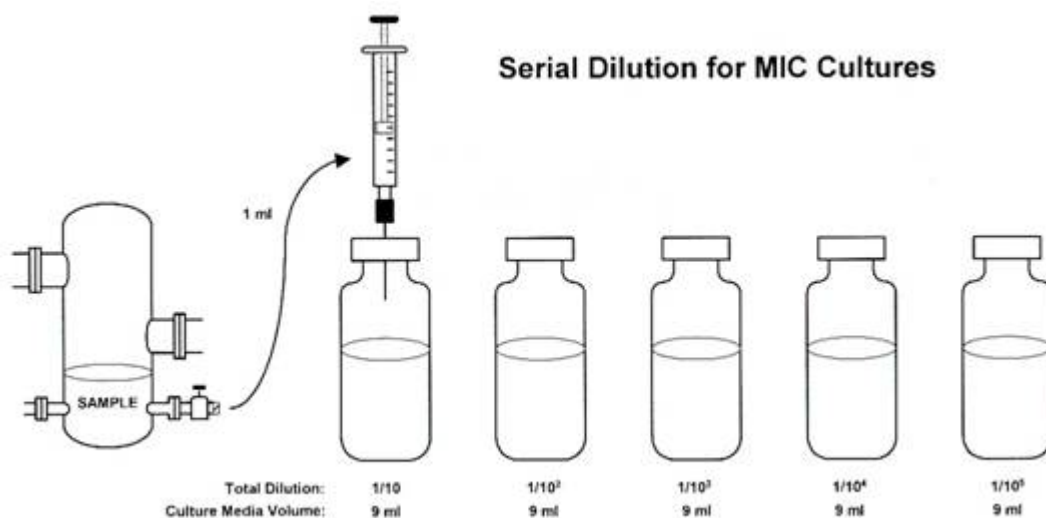

N. Repeat for Vial #1 of each Bacteria Culture set.

7. Serial Dilution

A. Prepare the remaining vials for inoculation.

- (1) Inoculation of subsequent vials may be done immediately in the field or within a few hours.

UNCONTROLLED IF PRINTED

(2) Remove the tab tops from the remaining vials with a clean tool. Thoroughly wipe the tops and septa of all vials with a clean alcohol pad.

B. Using a new sterile syringe/needle and holding the vial set up-side-down, insert the needle into Vial #1.

(1) Withdraw approximately 1 milliliter of the contents into the syringe.

(2) Without removing the needle, carefully and slowly discharge the contents back into the same vial.

(3) Avoid creating any gas bubbles.

(4) Repeat this process a total of at least three times.

C. Draw 1 mL of fluid into the syringe from Vial #1 and discharge into Vial #2.

(1) Withdraw approximately 1 mL of the contents and slowly discharge back into the same vial. Repeat this process at least three times

(2) Do not remove the needle from the vial.

(3) Avoid creating any gas bubbles.

D. Repeat Step C, taking fluid from Vial #2 into Vial #3 and consecutively with the remaining vials until all five vials are inoculated.

(1) Use the same syringe and needle for the entire serial dilution process.

(2) The following diagram shows the above serial dilution process.

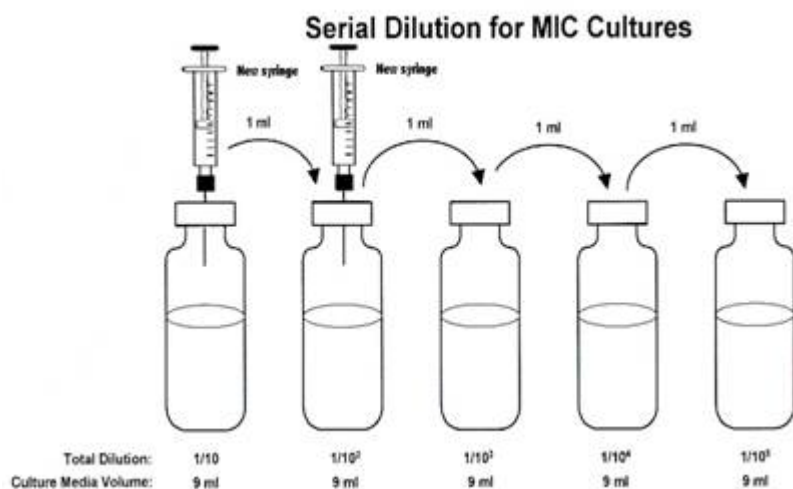

E. After all vials in the series are inoculated, dispose the syringe/needle into a Sharps Container (if available).

F. Repeat the process for each Bacteria Culture type being tested.

G. Dispose of the latex gloves.

8. Incubation and Results

A. Incubate the inoculated vials.

(1) The incubation temperature should be within $\pm 10^{\circ}\text{C}$ (18°F) of the water temperature at the time the sample was obtained.

(2) The incubation period will vary according to the test type.

UNCONTROLLED IF PRINTED

B. Acid-Producing Bacteria (APB) Determination

- (1) Incubation period for APB vials should be a minimum of 5 days to a maximum of 14 days.
- (2) Interim (daily or weekly) results may be recorded for information purposes only.
- (3) Positive vials are confirmed when phenol red dextrose media changes color from red to yellow along with increased turbidity (cloudiness).
- (4) Estimate the bacteria level using Table B.

C. Sulfate-Reducing Bacteria (SRB) Determination

- (1) Incubation period for SRB vials should be a minimum of 28 days.
- (2) Interim (daily or weekly) results may be recorded for information purposes only.
- (3) Positive vials are confirmed when sulfate reducer nutrient vials turn black.
- (4) Estimate the bacteria level using Table B.

D. The bacteria levels can be estimated by utilizing Table B below.

Table B. Interpretations of Observations

# of Positive Vials	Actual Dilution of Sample	Growth (+) Indicates (Bacteria per mL)	Reported Bacteria Colonies per mL
1	1:10	1 to 9	10
2	1:100	10 to 99	102
3	1:1,000	100 to 999	103
4	1:10,000	1,000 to 9,999	104
5	1:100,000	10,000 to 99,999	105

- (1) If waters produce positive results in all the vials tested, the sample is infected and the test results should be reported as greater than or equal to 10n, n being the number of vials used.
- (2) If a gap or skip occurs within the dilution series, the interpretation of the results is based on the number of positive vials.
- (3) The skip may be noted in the comments section of the form as additional information.
- (4) Contamination of the vials may have occurred if there is more than one negative vial between positive vials. If this occurs, disregard the odd positive vial.

Example 1: 3 Positive Vials (normal condition)



Example 2: Ignore "Skip". Record as 3 positive vials



Example 3: Disregard "Odd Positive". Record as 2 positive vials



Figure 1. Interpretation Examples

9. Documentation

A. Complete test kit form or [Form GSIC-2.06-1 - Field Analysis for MIC](#). Equivalent forms may also be utilized.

B. Maintain documentation in the project file.

GAS STORAGE INTERNAL CORROSION MONITORING
GSIC 2.07 Electric Resistance Corrosion Probe

January 1, 2013

1. General

A. This procedure describes a standardized method for field data collection from electric resistance (ER) corrosion probes during exposure while inserted in the process stream. Insertion and removal of the ER probes is covered under [GSIC 2.10](#) - Coupon/Probe Retractor Operation.

B. The following procedure is based on the Metal Samples ER4100 cylindrical probe and MS1500E Intrinsically Safe ER Probe Reader. For other devices consult the manufacturer's information.

C. The process of field ER probe monitoring is applicable to the storage field gathering system and station piping.

D. Per 49 CFR § 192.477, coupons or "other suitable means" must be evaluated two (2) times each calendar year, with intervals not to exceed 7 ½ months. Ameren Illinois typically collects ER probe data at various locations within each storage field coinciding with the injection and withdrawal seasons. Shorter periods between ER probe exposures may also be used on a case-by-case basis.

E. Corrosion monitoring devices should be placed in a location where corrosion is most likely to occur.

2. Part 192 Reference

49 CFR §§ 192.475, 192.476, & 192.477

3. Safety Considerations

Refer to [GSIC 1.02](#) - Safety Considerations. The data collection device should be rated as Intrinsically Safe or have other suitable rating to not be an ignition hazard.

4. Collecting ER Probe Data

A. Refer to the specific ER Probe Reader Manual for instructions.

(1) Ensure the ER probe reading device is compatible with installed ER probe.

(2) Review the equipment specification to become familiar with the equipment.

CAUTION: Operating electronic devices may present a flammable gas ignition hazard. Verify electronic reader is Intrinsically Safe for the operating conditions or alternate means are provided to attain the required ignition safety conditions.

B. Connect ER probe to the reader to collect readings.

C. Save the data in the reader

D. Download or otherwise transfer the data to the applicable form

5. Calculation of Corrosion Rate

UNCONTROLLED IF PRINTED

- A. The output from the ER probe is a signal proportional to the element's metal loss. The corrosion rate is then calculated using multipliers specific to the probe type. The corrosion rate can then be expressed as the change in metal loss over time.
- B. Determine the probe multiplier based on the element type. This is typically labeled as Probe Life. Ameren typically uses ER probes with cylindrical element type.
- C. Obtain the signal readings and time from the applicable form.
- D. Use the following equation to determine the corrosion rate of the probe.

$$\text{Corrosion Rate (mpy)} = \frac{P \times 365}{1000} \times \frac{\Delta S}{\Delta t}$$

Where,

P = Probe Multiplier (dimensionless)

ΔS = Change in Signal (dimensionless)

Δt = Time between Readings (days)

6. Documentation

- A. The probe reading value, date and time of data storage should be recorded.
- B. Maintain documentation in the project file.

GAS STORAGE INTERNAL CORROSION MONITORING
GSIC 2.08 Linear Polarization Resistance (LPR) Probe

January 1, 2013

1. General

A. This procedure describes a standardized method for field data collection from linear polarization resistance (LPR) corrosion probes during exposure while inserted in the process stream. Insertion and removal of the LPR probes is covered under [GSIC 2.10](#) - Coupon/ Probe Retractor Operation.

B. The following procedure is based on the Metal Samples LP4100 probe and MS3500L Intrinsically Safe LPR Probe Reader. For other devices consult the manufacture's information.

C. The process of field LPR probe monitoring is applicable only to the storage field gathering system piping.

D. Per 49 CFR § 192.477, coupons or "other suitable means" must be evaluated two (2) times each calendar year, with intervals not to exceed 7 ½ months. Ameren typically collects LPR probe data at various locations within each storage field coinciding with the injection and withdrawal seasons. Shorter periods between LPR probe exposures may also be used on a case-by-case basis.

E. Corrosion monitoring devices should be placed in a location where corrosion is most likely to occur.

2. Part 192 Reference

49 CFR §§ 192.475, 192.476, & 192.477

3. Safety Considerations

A. Please refer to [GSIC 1.02](#) - Safety Considerations.

B. The Metal Samples MS3500L is rated as electrically Intrinsically Safe to be suitable for use in an ignition hazardous environment.

4. Collecting LPR Probe Data

A. Refer to the specific LPR Probe Reader Manual for instructions.

B. Ensure the LPR probe reading device is compatible with installed LPR probe.

C. Review the equipment specification to become familiar with the equipment.

CAUTION: Operating electronic devices may present a flammable gas ignition hazard. Verify electronic reader is Intrinsically Safe for the operating conditions or alternate means are provided to attain the required ignition safety conditions.

D. Connect LPR probe to the reader to collect readings.

E. Save the data in the reader

F. Download or otherwise transfer the data to the applicable form

G. The output from the LPR probe is typically a corrosion rate with units of mills per year (mpy).

5. Documentation

UNCONTROLLED IF PRINTED

- A. The probe reading value, date and time of data storage should be recorded.
- B. Maintain documentation in the project file

GAS STORAGE INTERNAL CORROSION MONITORING
GSIC 2.09 Field Testing Natural Gas for Oxygen

January 1, 2013

1. General

- A. This procedure describes a standardized method for field testing natural gas for trace oxygen content.
- B. This procedure is suitable for sampling "wet" gas and/or "dry" gas. The regulator and separator device set at the sample tap has a pressure range of 1 to 1000 psig.
- C. This procedure is based on using the Advanced Micro Instruments (AMI) model 1000RS portable Trace Oxygen Analyzer. The Corrosion Control personnel will determine if trace oxygen content testing is needed.
- D. Trace oxygen content testing if assigned, would most likely be performed when obtaining a high pressure natural gas spot sample for chromatograph analysis. See [GSIC 2.04](#) - Sampling Natural Gas for Laboratory Analysis.

2. Part 192 Reference

49 CFR §§ 192.475, 192.476, & 192.477

3. Safety Considerations

- A. Please refer to [GSIC 1.02](#) - Safety Considerations.
- B. The AMI 1000RS trace oxygen analyzer is rated as electrically Intrinsically Safe to be suitable for use in an ignition hazardous environment.

4. Analyzer Precautions

- A. The expected hydrogen sulfide content at the sampling location should be less than 10 ppm with normally supplied T-2 element. Refer to the equipment manual for hydrogen sulfide concentrations exceeding 10 ppm.
- B. During winter months, the instrument should be stored in a heated area when not in use.
- C. The analyzer should be calibrated on a monthly basis when used continuously.

5. Collecting Oxygen Measurements

- A. Refer to Oxygen Analyzer Manual for additional instructions.
- B. Rotate the Sample/Bypass valve to "On" so gas flows by the sensor. Refer to Figure 3 below.

CAUTION: The SAMPLE/BYPASS VALVE on the lower right front of the instrument must remain in the CLOSED POSITION except when the flow gas needs to be in contact with the sensor element. Sensor element contact with air significantly degrades instruments measurement performance.

- C. Allow several minutes for oxygen reading to stabilize, before collecting the concentration. The instrument measurement range is from 0.01 ppm to 100% oxygen concentration.

UNCONTROLLED IF PRINTED

D. When finished, rotate the Sample/Bypass valve to the "Off" position and disconnect the sample line. Due to the sensitivity of the instrument, it should be sealed off when not in use to prevent damage to the sensor.

E. Record or download the data stored on the instrument.

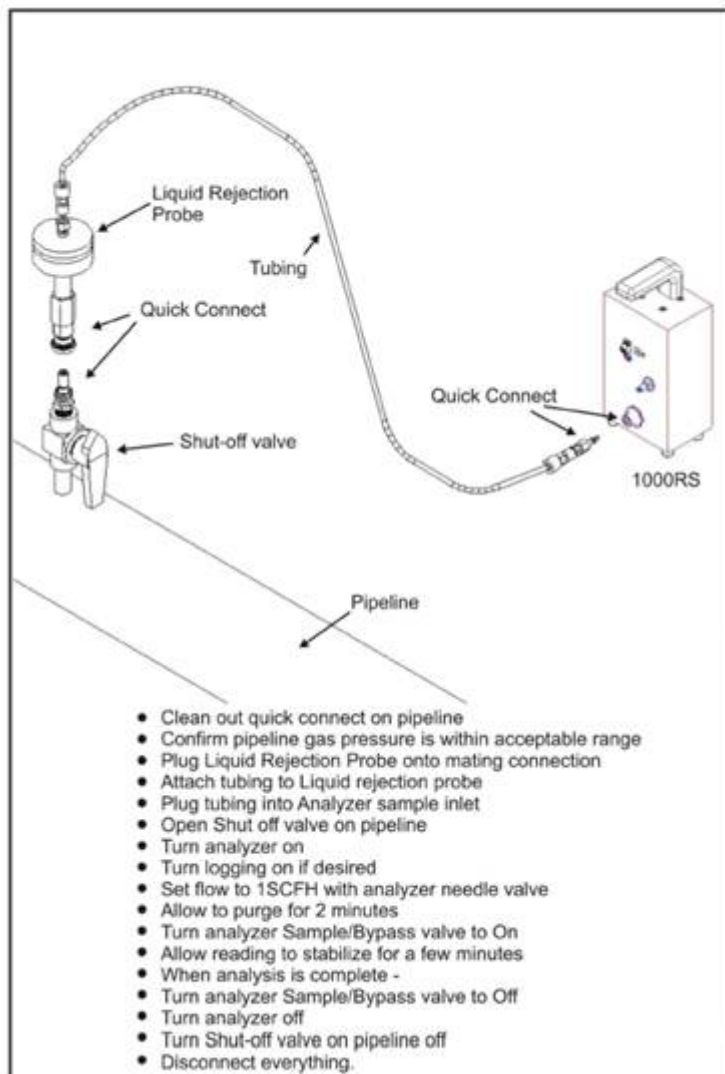

Figure 3 Sampling from a pipeline

6. Documentation

A. Record the oxygen content with units of ppm or % Oxygen on form [GSIC-2.04-1 - Field Gas Sampling](#), in the "Comments" column.

B. Retain documentation with the project file.

GAS STORAGE INTERNAL CORROSION MONITORING

January 1, 2013

GSIC 2.10 Coupon/Probe Retractor Operation

1. General

A. This procedure describes a standardized method for insertion and removal of the electric resistance (ER), Linear Polarization (LP) corrosion probes and metal loss coupons from a gas pipeline operating at line pressure.

B. Field data collection from (ER) or (LP) corrosion probes during exposure while inserted in the process stream is covered under [GSIC 2.07](#) - Electric Resistance (ER) Corrosion Probe and [GSIC 2.08](#) - Linear Polarization (LPR) Corrosion Probe. For specific instructions on field handling of corrosion metal coupons prior to or after exposure, refer to [GSIC 2.02](#) - Monitoring Corrosion Weight Loss Coupons.

C. The following procedure is based on the Metal Samples ER4100 ER probe, a LP 4100 LP probe, and/or the following metal loss coupon holders utilized at various storage fields. For other devices consult the manufacturer's information. These devices include the following:

- (1) Model M-1A Hand Insertable / Retractable Corrosion Coupon Holder
- (2) Model LP-750 Hand Insertable / Retractable Corrosion Coupon Holder
- (3) Model LP-500 Hand Insertable / Retractable Corrosion Coupon Holder

D. The process of field probe retraction or insertion is applicable only to the storage field gathering system piping.

2. Part 192 Reference

49 CFR §§ 192.475, 192.476, & 192.477

3. Tool Selection

A. The appropriate model of tool must be chosen based on Maximum Operating Pressures, Maximum Allowable Operating Pressures (MAOP), and Maximum Allowable Temperatures.

Note: For safe Hand Insertion process pressures may require a reduction in operating pressure.

B. Information pertaining to the typical tool models used by Ameren is provided below. For other devices consult with the manufacturer's information prior to use.

C. Metal Samples specifies that a SR2159 Easy Tool Retraction System be use when inserting or retracting the ER/LP Series 4100 probes from an operational pipeline process **with an operating pressure greater than 150 psig**.

D. For this procedure, the operating pressure is assumed to be greater than 150 psig and a retraction system **IS REQUIRED**.

E. Accurate Tool Company specifies that the following tools may be used under the specified operation pipeline conditions. These tools do not require an insertion tool when pressures are under the MOP.

Tool Name	Description	Maximum Operating Pressure (MOP) psi	Maximum Allowable Operating Pressure (MAOP) psi	Temperature (Degrees F)
M-1A	1/4" OD Rod	1000	1500	100

UNCONTROLLED IF PRINTED

LP-500FHT	1/4" OD Probe/Rod	500	1440	1000
LP-750HT	3/8" OD Probe/Rod	750	750	300

4. Safety Considerations

- A. Please refer to [GSIC 1.02](#) - Safety Considerations.
- B. Personal injury may occur to personnel performing or standing nearby improper operation of a probe/coupon retractor or retraction without a retractor.
- C. If the observations required during the insertion or retraction process do not meet specified requirements, cease operation and contact a supervisor.

5. Preparation

- A. Complete section for tasks prior to starting work on [Form GSIC-2.10-1- Insertion/Retraction Safety Check List](#).
- B. Obtain approval for the described tasks required prior to starting work
- C. Review the equipment specification to acquaint self with the equipment.
- D. Review pressure restrictions for insertion by hand per manufacturing instructions.
- E. Secure materials to perform work.

6. Insertion/Retraction of Device

- A. Identify the insertion/retraction tool to be used.
 - (1) Refer to section 3, Tool Selection, for tool specifications.
 - (2) Figure 1 and Figure 2, at the end of this document; provide an overview of the Metal Samples and Accurate Tool Company insertion/retraction tool.
- B. Review the manufacturing instructions for the specific insertion/retraction tool selected.
- C. Follow the insertion/retraction instructions for the specific tool selected.
 - (1) Insert the device (probe or coupon) with the insertion tool
 - (2) Recommend installing the device approximately 1/2 - inch from the bottom of the pipe or vessel.
 - (3) Install the safety chain with as little slack as possible per the Safety Chain instructions.
 - (4) Retract probe or coupon with tool.
 - (5) Re-install the Insertion tool per section 6. C.

7. Documentation

- A. Complete remaining portion of [Form GSIC-2.10-1- Insertion/Retraction Safety Check List](#).
- B. Maintain documentation in the project file.

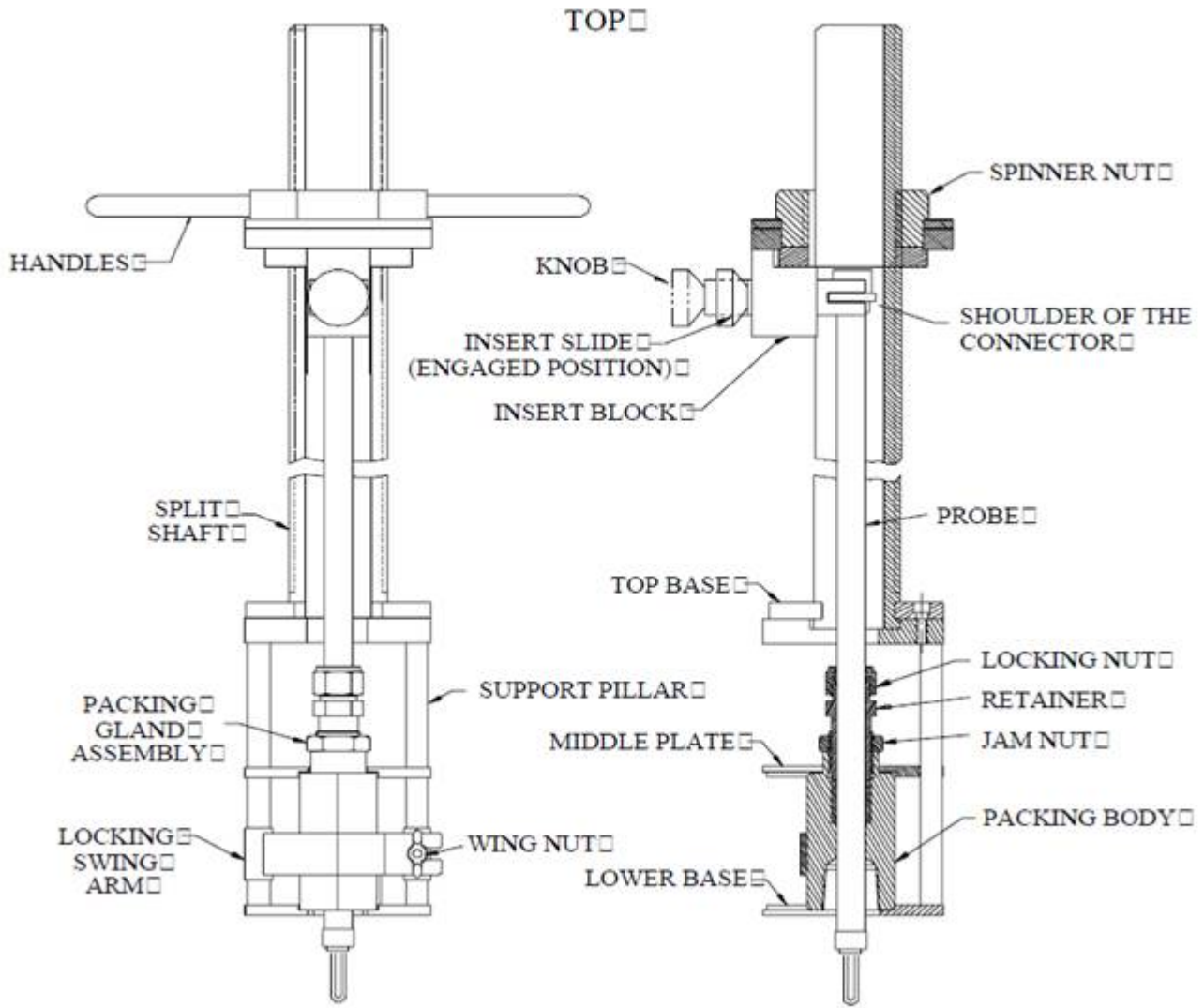

Figure 1. Easy Tool Retracting System

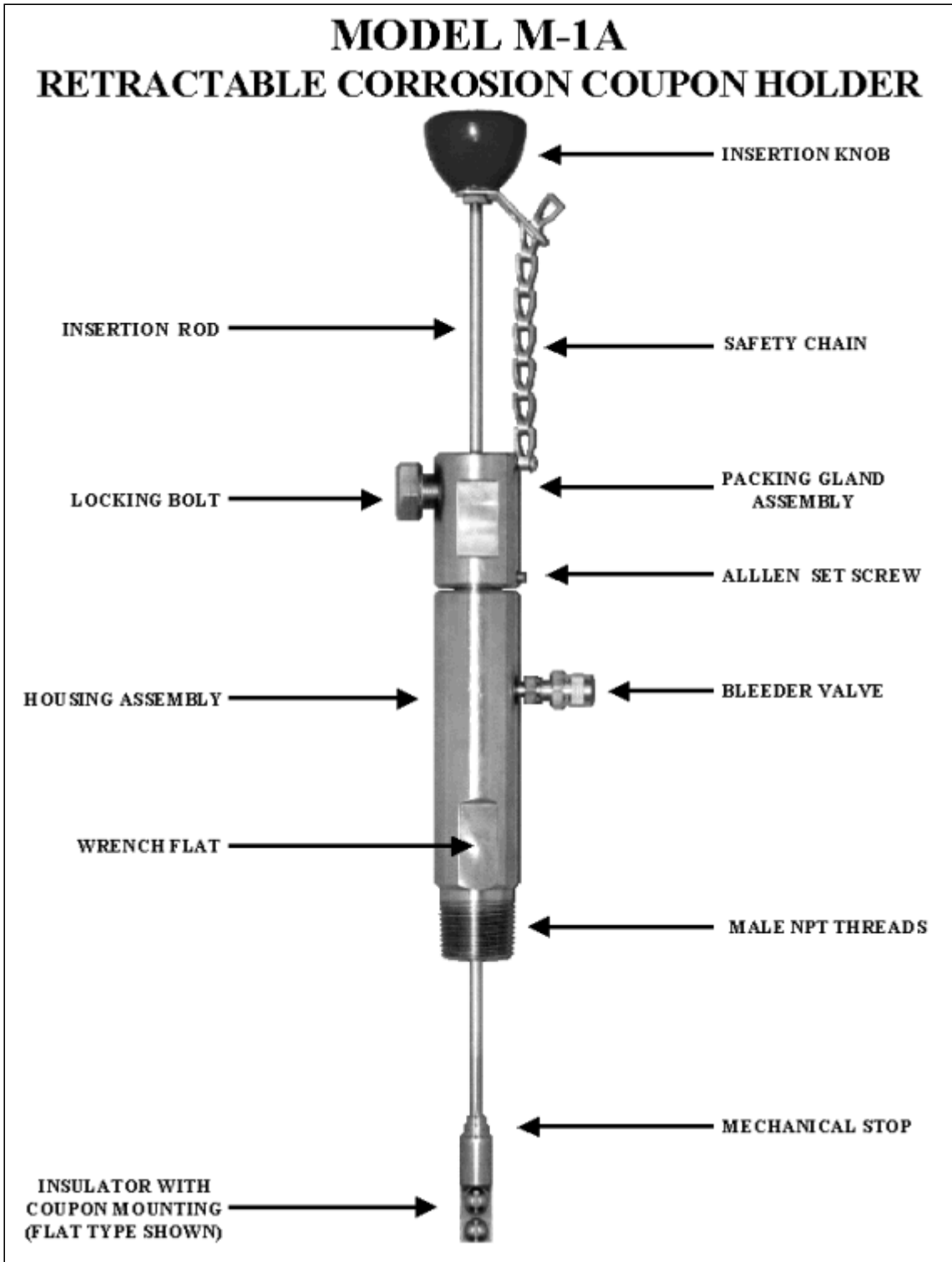

Figure 2. Retractable Corrosion Coupon Holder

GAS STORAGE INTERNAL CORROSION MONITORING
GSIC 4 Forms and Reference Materials

January 1, 2016

Listed below are forms and reference materials supporting this section of the Gas Operating & Maintenance Plan.

Click on the links to view the documents.

Forms

1. [GSIC - 2.01-1 Storage - Internal Exam Form](#)
2. [GSIC - 2.02-1 Weight-Loss Coupon Monitoring Report](#)
3. [GSIC - 2.03-1 Annual Field Liquid Sampling](#)
4. [GSIC - 2.04-1 Field Gas Sampling](#)
5. [GSIC - 2.05-1 Annual On-Site H₂S Readings](#)
6. [GSIC - 2.06-1 Field Analysis for MIC](#)
7. [GSIC - 2.10-1 Insertion/Retraction Safety Check List](#)

Reference Materials

1. [Reference 2.02-01 - Weight-Loss Coupon & Coupon Holder](#)
2. [Reference 2.02-02 - Accurate Tool Instructions For Hand Insertion Tools](#)
3. [Reference 2.02-03 - The Accurate Retractable Corrosion Coupon Holder](#)
4. [Reference 2.02-04 - Coupon Holders](#)
5. [Reference 2.02-05 - Metal Samples Insulators, Washers & Spacers](#)
6. [Reference 2.02-06 - Model RT4000 Coupon Insertion System](#)
7. [Reference 2.04-01 - MSA H₂S - 100 Detector Tube](#)
8. [Reference 2.04-02 - MSA H₂S - 1 Detector Tube](#)
9. [Reference 2.04-03 - Cole Parmer Tygon SE-200 Tubing and Fittings](#)
10. [Reference 2.04-04 - MSA Kwik-Draw Sample Pump Specification](#)
11. [Reference 2.07-01 - Model ER4100 Series Electrical Resistance Probe](#)
12. [Reference 2.07-02 - Model MS1500E Data Logger \(intrinsically safe\)](#)
13. [Reference 2.08-01 - Model LP1100 & LP4100 Linear Polarization Resistance Probe](#)
14. [Reference 2.08-02 - Model MS3500L and 3510L Remote LPR Data Logger](#)
15. [Reference 2.09-01 - Model 1000RS Portable Trace Oxygen Analyzer Manual](#)
16. [Reference 2.10-01 - AMI Guardian Regulator & Liquid Separator](#)
17. [Reference 2.10-02 - Metal Samples Safety Chain Factory Installation](#)
18. [Reference 2.10-03 - Metal Samples SR2159 Easytool Oper & Maint Manual](#)
19. [Reference 2.10-04 - Metal Samples Length Calc and Access for Retractable System](#)
20. [Reference 2.10-05 - Metal Samples Packing Gland Instructions](#)
21. [Reference 2.10-06 - Metal Samples SR2159 Retractor Video](#)
22. [Reference 2.10-07 - Accurate Tools Insertion & Retraction Sys Instructions](#)
23. [Reference 2.10-08 - Accurate Tools Retractable Systems Catalog](#)
24. [Un-Referenced 01 - WT Balls Brochure](#)
25. [Un-Referenced 02 - JACAM WT Balls](#)

UNCONTROLLED IF PRINTED

26. [Un-Referenced 03 - Sensit Gold CGI Instructions](#)

Supersedes: January 1, 2013

SECT 6 - Design, Construction Storage Wells

DESIGN, CONSTRUCTION STORAGE WELLS SECT 6.0 - Table of Contents

October 15, 2018

Procedures

Wellhead Equipment and Valves

[SECT 6.2](#)

1. General
2. Reference
3. Wellhead Equipment Design
4. Pressure Rating
5. Existing Equipment
6. Emergency Shutdown Valves

Well Casing

[SECT 6.3](#)

1. General
2. Reference
3. Surface Casing
4. Production Casing
5. Handling
6. Connectors

Casing Cementing Practices

[SECT 6.4](#)

1. General
2. Reference
3. Cement in Well Construction and Remedial Work
4. Cement Slurry Design and Controls
5. Cement Pumping Design
6. Cement Evaluation and Location

Completion and Stimulation

[SECT 6.5](#)

1. General
2. Reference
3. Fracture Stimulation

Well Closure (Plugging and Abandonment)

[SECT 6.7](#)

UNCONTROLLED IF PRINTED

1. General
2. Reference
3. Storage Zone Isolation
4. Abandoned and Well Maintenance

Environmental, Safety and Health

[SECT 6.8](#)

1. General
2. Reference
3. Design and Construction Safeguards
4. Operations and Maintenance Safeguards

Testing and Commissioning

[SECT 6.9](#)

1. General
2. Reference
3. Testing Methods

Monitoring of Construction Activities

[SECT 6.10](#)

1. General
2. Reference
3. Resolution of Issues

Recordkeeping

[SECT 6.11](#)

1. General
2. Reference
3. Well Work Records
4. Permitting, Procedures, Personnel and Equipment Records

Forms and Reference Materials

[SECT 6.20](#)

Forms

1. Well Integrity Pressure Test Form

DESIGN, CONSTRUCTION STORAGE WELLS
SECT 6.2 Wellhead Equipment and Valves

October 15, 2018

1. General

A. This section describes new and replacement wellhead equipment, including associated fittings, flanges, and valves. All should conform to API 6A.

B. This section addresses API RP 1171 6.2.1-6.2.5.

2. Reference

A. API RP 1171 Section 6.2 (pg. 13-14)

B. API 6A Specification of Wellhead and Christmas Tree

C. API 14A Specification of Subsurface Safety Valve Equipment

D. API 14B Design, Installation, Operation, Test, and Redress of Subsurface Safety Valve Systems

3. Wellhead Equipment Design

A. New and replacement wellheads shall allow for full-diameter entry to the wellbore.

B. Well shall be equipped with valves to provide isolation of the well from the pipeline system and to allow for entry into the well.

4. Pressure Rating

A. Wellhead equipment shall have operating pressure ratings sufficient to exceed the maximum anticipated operating pressure.

B. Wellhead design should include evaluation of the following:

(a) Treating and stimulation pressures

(b) Flow rates

(c) Fluid chemical composition of produced fluids and fluids used in well stimulation

(d) Possible solids production

(e) Possible increase in the maximum operating pressure

(f) Intended flow path

(g) Accommodation for pressure and/or temperature monitoring of tubular and annular spaces

5. Existing Equipment

A. Existing wellhead equipment is accepted if it has demonstrated containment of maximum operating pressure, but shall be further evaluated for suitability before increasing the operating pressure beyond the historical maximum.

UNCONTROLLED IF PRINTED

6. Emergency Shutdown Valves

A. The operator shall evaluate the need for any type of emergency shutdown valve by reviewing the following:

- (1) Distance from dwellings of human occupancy or other areas where people assemble
- (2) Gas composition, total fluid flow, and maximum flow potential
- (3) Distance between wellheads or between a wellhead and other facilities, and access availability for drilling and service rigs
- (4) Added risks created by installation and servicing requirements of safety valves
- (5) Risk to and from the well related to roadways, rights of way, railways, airports, and industrial facilities
- (6) Alternative protection measures that could be afforded by barricaded or distance or other measures
- (7) Present and predicted development of the surrounding area, topography, and regional drainage systems and environmental considerations

DESIGN, CONSTRUCTION STORAGE WELLS
SECT 6.3 - Well Casing

April 1, 2021

1. General

A. New well construction shall be completed with two or more strings of casing as needed to:

- (1) Protect groundwater
- (2) Control wellbore conditions
- (3) Isolate the storage gas within the storage reservoir
- (4) Inject storage gas from the pipeline into and withdraw out of the storage reservoir to the pipeline
- (5) Designed in accordance with API-5C3.
- (6) Conform to state regulations

B. This section addresses API RP 1171 6.3.1-6.3.7

2. Reference

A. API RP 1171 Section 6.3 (pg. 15-16)

B. API 5C3 -Bulletin On Formulas And Calculations For Casing, Tubing, Drill Pipe And Line Pipe Properties

C. API 14E -Recommended Practice for Design and Installation of Offshore Production Platform Piping Systems

D. API 5CT -Specification for Casing and Tubing

E. API 5A3 -Evaluation and testing of thread compounds for use with casing, tubing, line pipe and drill stem elements

3. Surface Casing

A. The surface casing shall be of sufficient size, grade and depth to support subsequent drilling operations and to protect groundwater.

4. Production Casing

A. The production casing shall be of adequate size and strength to maintain the well integrity and be compatible with fluid chemical compositions.

B. The production casing shall be free of open perforations or holes other than the planned completion intervals. Perforations created for investigative or remedial work shall be sealed to establish hydraulic isolation.

5. Handling

A. Casing shall be stored, transported, lifted and installed as specified by the manufacturer and in accordance with API 5C1.

UNCONTROLLED IF PRINTED

6. Connectors

- A. Casing connections shall be designed to accommodate loads associated with placement.
- B. Casing shall maintain a gas seal under anticipated wellbore flow conditions and subsequent work in the wellbore.
- C. Casing connections shall be made up according to manufacturer specification or in accordance with API 5CT.
- D. Thread compound or lubricant shall be compatible with the expected wellbore environment and shall be consistent with the manufacturer's recommended lubricant or API 5A3.

DESIGN, CONSTRUCTION STORAGE WELLS
SECT 6.4 - Casing Cementing Practices

October 15, 2018

1. General

A. This section describes the purpose of cement in the construction of new or reworked natural gas storage well. The cement is to maintain the integrity of the storage reservoir by providing isolation of the reservoir from communication with other sources of permeability or porosity through the drilled wellbore. In new construction, isolation is accomplished by filling the annular space between the casing and formation with competent cement to create a seal so that communication of fluids between the wellbore and the storage zone or other zones of interest is prevented.

B. This section addresses API RP 1171 6.4.1-6.4.6.

2. Reference

A. API RP 1171 Section 6.4 (pg. 17-19)

B. API 10A-Specification for Cements and Materials for Well Cementing

C. ASTM C150/C150M-Standard Specification for Portland Cement

D. API 10TR1-Principles and practices regarding the evaluation and repair of primary cementation of casing strings in oil and gas wells

E. API 10D-2-Recommended Practice for Centralizer Placement and Stop Collar Testing

F. API 10TR4-Technical Report on Considerations Regarding Selection of Centralizers for Primary Cementing Operations

G. API 65-2- Isolating Potential Flow Zones

3. Cement in Well Construction and Remedial Work

A. Cement functions in construction, remediation and plugging of gas storage wells:

(1) Production Casing and Liners: Use cement slurry designed for hydrostatic weight control and strength requirements. The cement should be designed for sufficient volume to:

(a) Circulate to surface, or

(b) Circulate to a point within the next casing string, or

(c) Establish zonal isolation of permeable zones

(2) Cement slurry for plugs should be designed for both cement blend and placement to have mechanical and isolation properties.

(3) Remedial cementing such as used to squeeze cement outside of the casing in order to restore wellbore, integrity, seal communicating zone, or provide isolation should be designed so that isolation of the storage zone from all other sources of porosity and permeability is achieved.

4. Cement Slurry Design and Controls

UNCONTROLLED IF PRINTED

- A. Design cement slurry by reviewing type of formations, temperature, and requirements such as water ratio, desired, compressive strength, prevention from contamination by formation fluids and various additives to control fluid rheology and reaction time.
- B. Density of cement shall be designed such that the fracture gradient of the storage zone is not exceeded and such that lost circulation potential of any exposed zone is minimized.

5. Cement Pumping Design

- A. The proper placement of the cement slurry provides well integrity by isolating the reservoir from communication with other sources of potential fluid flow.
- B. The operator should use spacers and/or pre-flushes to help remove any mud cake that may exist. The spacers should isolate dissimilar fluids to prevent potential cement contamination.

6. Cement Evaluation and Location

- A. Evaluation of cement placement and quality is done to determine that a competent seal exists to prevent the communication of fluids from the storage zone or other zones of interest.
 - (1) The location and quality of the cement bond or seal between the production casing, or liner if applicable, and the formation shall be evaluated to determine whether adequate formation and pipe bonding has been achieved to prevent the migration of gas and fluids between zones.
 - (2) Cement placement and bond quality shall be evaluated with a cement bond log or other means that can demonstrate the sealing potential of the cement.

DESIGN, CONSTRUCTION STORAGE WELLS
SECT 6.5 - Completion and Stimulation

October 15, 2018

1. General

- A. This section describes well completion and stimulation operations to verify that pressure, flow rates, and other mechanical conditions have no adverse impact on the storage reservoir, caprock, or the mechanical integrity of the well.
- B. Casing and wellhead design, installation parameter workover history, and previous mechanical integrity tests should be reviewed to verify that stimulation and completions loads do not exceed the pressure limits and safety factors causing failure to the well's mechanical integrity.
- C. This section addresses API RP 1171 6.5.1-6.5.3.

2. Reference

- A. API RP 1171 Section 6.5 (pg.19)
- B. API HF1-Hydraulic Fracturing Operations-Well Construction and Integrity Guidelines
- C. API HF2-Water Management Associated with Hydraulic Fracturing
- D. API HF3-Practices for Mitigating Surface Impacts Associated with Hydraulic Fracturing

3. Fracture Stimulation

- A. When a fracture treatment is applied, it shall be conducted in a manner such that the fracture height or length does not compromise the integrity of the storage reservoir.

DESIGN, CONSTRUCTION STORAGE WELLS
SECT 6.7 - Well Closure - Plugging and Abandonment

April 1, 2021

1. General

- A. This section describes the design and well abandonment for long-term isolation of the storage zone in order to prevent fluid flow between the storage zone and any other penetrated zone and the surface.
- B. This section addresses API RP 1171 6.7.1-6.7.3.

2. Reference

- A. API RP 1171 Section 6.7 (pg.20-21)
- B. API E3-Well Abandonment and Inactive Well Practices for U.S. Exploration and Production Operations
- C. API 10A-Specification for Cements and Materials for Well Cementing
- D. ASTM C150/C150M-Standard Specification for Portland Cement

3. Storage Zone Isolation

- A. Use cement plugs and/or mechanical plugs to isolate the storage zone from fluid migration. The use of hydrostatic pressure as a sole means of isolation shall not be acceptable.
- B. The operator shall determine the location of groundwater and hydrocarbon bearing zones penetrated by the well to be abandoned, and the condition of the casing and cement across those zones to prevent communication between any those zones during and after plugging the well.
- C. Condition of the well should be evaluated to determine if any issue would limit access to wellbore or hinder placing plugs across storage zone.
- D. The operator shall verify that the casing-borehole cement seals the storage interval in the well being abandoned in order to achieve annular isolation and prevent communication.
- E. The operator shall verify the presence and location of a cement plug after the plug has set and has reached a sufficient compressive strength.
- F. The operator shall correct deviations which may threaten isolation objectives of the plug.

4. Abandoned and Well Maintenance

- A. The operator shall repair a failed plug.
- B. The operator shall repair a well with any leak indication that may suggest a lack of isolation of the storage reservoir.
- C. The operator shall install a surface plug and cap to maintain physical and site security and will include the API number or other form of identification.

UNCONTROLLED IF PRINTED

DESIGN, CONSTRUCTION STORAGE WELLS
SECT 6.9 - Testing and Commissioning

April 1, 2023

1. General

A. This section describes the minimum requirements for testing and commissioning the functional integrity in the design and construction of natural gas storage wells.

B. This section addresses API RP 1171 6.9.

2. Reference

A. API RP 1171 Section 6.9 (pg. 22)

3. Testing Methods

A. A new well, or a well that has had its existing production casing modified from its previous condition during workover activities, shall be tested to demonstrate mechanical integrity and suitability for the designed operating conditions prior to commissioning by one of the following test:

(a) For new well construction, the production casing shall be tested prior to drilling out the shoe, taking into account the cement design factors so that this test does not compromise the cement integrity.

(b) For existing production casing, the production casing shall be tested after setting a retrievable plug as close as practical to the top of the storage formation.

(c) For a well completed with tubing and packer, the tubing-casing annulus shall be tested.

B. The operator shall design a test so the maximum pressure on the packer seat and the pressure at any point in the wellbore during the test does not compromise the mechanical integrity of the well.

NOTE:

A commonly used test parameter is an initial test pressure of 1.1 times the maximum allowable operating pressure, with test duration of at least 30 minutes and a pressure drop not exceeding 10% of the initial test pressure.

Document Rescission

SECT 6.9 Design, Construction Storage Wells: Testing and Commissioning, October 15, 2018

Revision Notes

Location of Changes	Summary of Changes
---------------------	--------------------

UNCONTROLLED IF PRINTED

Section 3. B.

Added a NOTE

DESIGN, CONSTRUCTION STORAGE WELLS
SECT 6.10 - Monitoring of Construction Activities

April 1, 2023

1. General

- A. This section describes the minimum requirements for monitoring of construction activities.
- B. This section addresses API RP 1171 6.10.

2. Reference

- A. API RP 1171 Section 6.10 (pg. 22-23)
- B. Gas Storage Form 11.11.1 Management of Change**

3. Resolution of Issues

- A. The operator should monitor and address issues or problems encountered during drilling, completion, and stimulation of a well. If the resolution of encountered issues or problems causes the operator to deviate from the original design or to alter the procedures for a well, the operator shall document the changes and keep the document in the daily well records.
- B. The operator shall resolve issues in a manner that maintains functional integrity of the well and storage reservoir prior to commissioning the well for service.

Document Rescission

SECT 6.10 Design, Construction Storage Wells: Monitoring of Construction Activities, October 15, 2018

Revision Notes

Location of Changes	Summary of Changes
2. Reference	Added – Gas Storage Form 11.11.1 Management of Change

DESIGN, CONSTRUCTION STORAGE WELLS
SECT 6.11 - Recordkeeping

October 15, 2018

1. General

- A. This section describes the minimum requirements for recordkeeping activities.
- B. This section addresses API RP 1171 6.11.

2. Reference

- A. API RP 1171 Section 6.11 (pg. 23-25)

3. Well Work Records

- A. Records of well completion (as-built), new well construction and well work activities shall be maintained for the life of the facility.
- B. These records shall include, as applicable and available, the items listed below as referenced in each subsection:
 - (1) 6.2 Wellhead Equipment and Valves
 - (2) 6.3 Well Casing
 - (3) 6.4 Casing Cementing Practices
 - (4) 6.5 Completion and Stimulation Considerations
 - (5) 6.6 Well Remediation
 - (6) 6.7 Well Closure
 - (7) 6.8 Environment, Health, and Safety
 - (8) 6.9 Testing and Commissioning
 - (9) 6.10 Monitoring of Construction Activities

4. Permitting, Procedures, Personnel and Equipment Records

- A. Records relating to permitting, procedures, personnel, and equipment shall be retained for a period that meets regulatory requirements, or where no regulatory requirements exist, intervals as determined by the operator.
- B. These records shall include, as applicable and available, the items listed below as referenced in each subsection.
 - (1) 6.8 Environment, Health and Safety
 - (2) 6.10 Monitoring of Construction Activities

DESIGN, CONSTRUCTION STORAGE WELLS
SECT 6.20 - Forms and Reference Materials

April 1, 2021

Listed below are forms supporting this section of the Gas Operating & Maintenance Plan.
Click on the links to view the documents.

Forms

SECT 7 - Attainment of Maximum Reservoir Pressure and Total Capacity

ATTAINMENT OF MAXIMUM RESERVOIR PRESSURE AND TOTAL CAPACITY - October 15, 2018

SECT 7.0 Table of Contents

Procedures

Testing and Commissioning

[SECT 7.2](#)

1. General
2. Reference
3. Integrity Assurance

Reservoir Integrity Monitoring

[SECT 7.3](#)

1. General
2. Reference
3. Monitoring and Analysis Methods

Recordkeeping

[SECT 7.5](#)

1. General
2. Reference
3. Recordkeeping

ATTAINMENT OF MAXIMUM RESERVOIR PRESSURE AND TOTAL CAPACITY
OCTOBER 15, 2018
SECT 7.2 - Testing and Commissioning

1. General

- A. This section describes the minimum requirements for testing and commissioning the functional integrity of the natural gas storage reservoir and wells established.
- B. This section addresses API RP 1171 7.2.

2. Reference

- A. API RP 1171 Section 7.2 (pg. 25-26)

3. Integrity Assurance

- A. Mechanical integrity test and/or mechanical condition evaluation shall be performed prior to project commissioning in order to verify that each well is capable of meeting the designed operating conditions. Requirements related to well mechanical integrity testing are covered in API 1171 section 6.9 (pg. 22).

ATTAINMENT OF MAXIMUM RESERVOIR PRESSURE AND TOTAL CAPACITY - October 15, 2018

SECT 7.3 - Reservoir Integrity Monitoring

1. General

- A. This section describes the minimum requirements for reservoir integrity monitoring and the methods for analysis.
- B. The material balance behavior of a storage reservoir shall be monitored relative to the original design and expected reservoir behavior established prior to commissioning and start-up.
- C. Unexpected conditions detected during monitoring shall be evaluated and corrected in order to avoid an incident or loss.
- D. Monitoring frequency should be based on factors such as reservoir and well fluid loss and flow potential.
- E. This section addresses API RP 1171 7.3.

2. Reference

- A. API RP 1171 Section 7.3 (pg. 26)

3. Monitoring and Analysis Methods

- A. Average reservoir pressure versus inventory shall be monitored and compared to expected conditions in order to allow for the discovery and correction of any unexpected conditions.
- B. Typically a shut-in key indicator well(s) or an observation well(s) that represents the average shut-in reservoir pressure provides the most useful pressure-inventory relationship.
- C. In lieu of shut-in observation wells, the relationship may be based on a flowing well pressure.
- D. Liquid level should be taken into account when using observation wells.

ATTAINMENT OF MAXIMUM RESERVOIR PRESSURE AND TOTAL CAPACITY - October 15, 2018

SECT 7.5 - Recordkeeping

1. General

A. This section describes the minimum requirements for recordkeeping on natural gas storage records related to its monitoring and testing.

B. This section addresses API RP 1171 7.5.

2. Reference

A. API RP 1171 Section 7.5 (pg. 27)

3. Recordkeeping

A. Records of natural gas storage testing and monitoring activities covered under this section shall be maintained for the life of the facility.

B. The records shall include, as applicable and available:

(1) Reservoir and well mechanical integrity records that demonstrate functional integrity during commissioning, including monitoring data and analyses.

(2) Well testing records and records of well actions taken during commissioning.

(3) Regulatory records for project commissioning include permit applications, permits, and all reports and correspondence with regulatory agencies.

SECT 8 - Risk Management for Storage Operations

RISK MANAGEMENT FOR STORAGE OPERATIONS

October 15, 2018

SECT 8.0 - Table of Contents

Procedures

Risk Management

[SECT 8.2](#)

1. General
2. Reference
3. Risk Management Requirements
4. Documentation

Data Collection and Integration

[SECT 8.3](#)

1. General
2. Reference
3. Data Sources
4. Documentation

Threat and Hazard Identification and Analysis

[SECT 8.4](#)

1. General
2. Reference
3. Methodology
4. Documentation

Risk Assessment

[SECT 8.5](#)

1. General
2. Reference
3. Methodology
4. Documentation

Periodic Review and Reassessment

[SECT 8.7](#)

1. General
2. Reference
3. Frequency
4. New Threats and Hazards
5. Documentation

UNCONTROLLED IF PRINTED

Risk Assessment Procedures

[SECT 8.7.4](#)

1. General
2. Reference
3. Timeline
4. Data to be Reviewed
5. Documentation

Recordkeeping

[SECT 8.8](#)

1. General
2. Reference
3. Recordkeeping
4. Documentation

Forms and Reference Materials

[SECT 8.20](#)

Forms

1. 8.8 Risk Model Recordkeeping Form

RISK MANAGEMENT FOR STORAGE OPERATIONS
SECT 8.2 - Risk Management

October 15, 2018

1. General

- A. This section describes the minimum requirements for developing, implementing, and documenting a program to manage risk.
- B. This section addresses API RP 1171 8.2.

2. Reference

- A. API RP 1171 Section 8.2 (pg. 28)

3. Risk Management Requirements

- A. The operator shall develop, implement, and document a program to manage risk.
- B. The program to manage risk should include:
 - (1) Data collection
 - (2) Identification of potential threats and hazards to the storage operation
 - (3) Risk analysis including estimation of the likelihood of occurrence of events related to each threat
 - (4) The likelihood of occurrence and potential severity of the consequence of such events
 - (5) The preventative, mitigative, and monitoring process to reduce the likelihood of occurrence
 - (6) The likelihood and severity of consequences
 - (7) A periodic review and reassessment of the processes

4. Documentation

- A. The risk management program for each of Ameren's storage fields is stored electronically.
- B. Each of the 12 storage fields has an individual risk management program; each risk management program shall be reviewed and reassessed as described in [SECT 8.7.4](#).

RISK MANAGEMENT FOR STORAGE OPERATIONS
SECT 8.3 - Data Collection and Integration

October 15, 2018

1. General

- A. This section describes the minimum requirements for data collection and integration relevant to a storage field for risk management.
- B. This section addresses API RP 1171 8.3.

2. Reference

- A. API RP 1171 Section 8.3 (pg. 28)

3. Data Sources

- A. The operator shall use available information such as performance data collected through:
 - (1) The field history
 - (2) Operations and maintenance (O&M) activities
 - (3) Geotechnical data such as well logs
 - (4) Engineering data
 - (5) Completion reports

4. Documentation

- A. The risk management program for each of Ameren's storage fields is stored electronically.
- B. The specifications and processes used in the data collection and integration process to evaluate risk for each of Ameren's gas storage wells can be viewed electronically.

RISK MANAGEMENT FOR STORAGE OPERATIONS
SECT 8.4 - Threat and Hazard Identification and Analysis

March 28, 2022

1. General

- A. This section describes the minimum requirements for threat and hazard identification and analysis.
- B. A hazard is a situation or condition that has the potential to cause loss, damage, or harm to a storage well, well site or reservoir and thus affect the functional integrity of the storage operation.
- C. A threat to storage functional integrity can be created by an encounter with or an activation of a hazard in the course of the storage operation.
- D. The operator may determine that some facilities are not susceptible to specific threats based on existing information, in which case the operator can provide justification and documentation for the exclusion of a specific threat.
- E. A lack of data or information should not be used as justification to exclude a specific threat.
- F. This section addresses API RP 1171 8.4.

2. Reference

- A. API RP 1171 Section 8.4 (pg. 28)
- B. Risk Management Well Integrity Paper

3. Methodology

- A. The operator shall evaluate the potential threats and hazards impacting storage wells and reservoirs.
- B. Each well and reservoir threat and hazard identified and evaluated in the risk model are listed in the Risk Management Well Integrity Paper.

4. Documentation

- A. The risk management document for each of Ameren's storage fields are stored electronically.
- B. The specifications and processes used in the data collection and integration process to evaluate risk for each of Ameren's gas storage wells can be viewed electronically in the Risk Model and the Risk Management Well Integrity Paper.

Supersedes: October 15, 2018

UNCONTROLLED IF PRINTED

RISK MANAGEMENT FOR STORAGE OPERATIONS
SECT 8.5 - Risk Assessment

October 15, 2018

1. General

A. This section describes the minimum requirements for developing a risk assessment using tools and techniques that will evaluate and prioritize risks, to direct risk management activities that promote functional integrity of the storage operation.

B. This section addresses API RP 1171 8.5

2. Reference

A. API RP 1171 Section 8.5 (pg. 31)

3. Methodology

A. The operator shall assess risk related to the storage operation using a consistent process.

B. The operator shall review the results of the risk assessment to determine whether the risk assessment, resulting prioritization, or ranking represents its facilities and characterizes the risks.

4. Documentation

A. Risk Model Recordkeeping Form - Form 8.8 stored electronically.

RISK MANAGEMENT FOR STORAGE OPERATIONS
SECT 8.7 - Periodic Review and Reassessment

October 15, 2018

1. General

- A. This section describes the minimum requirements for the periodic review and reassessment of risk management programs and activities.
- B. The operator shall assess the effectiveness of risk monitoring and risk management programs and maintain a continual review and improvement cycle in risk management activities to provide functional integrity of the storage operation.
- C. This section addresses API RP 1171 8.7.1 - 8.7.6

2. Reference

- A. API RP 1171 Section 8.7 (pg. 35)

3. Frequency

- A. The operator shall define a review frequency for the risk assessment and perform a review and update of the risk assessment in accordance with the defined frequency
- B. The frequency is defined in [SECT 8.7.4](#).

4. New Threats and Hazards

- A. If during the course of operations new threats or hazards are identified, or the impact of threats or hazards changes markedly, the operator shall assess the risk associated with new conditions and evaluate the prioritize risk management options in accordance with the risk assessment.

5. Documentation

- A. The risk management program for each of Ameren's storage fields is stored electronically.
- B. The procedure defined in [SECT 8.7.4](#) is stored electronically.

RISK MANAGEMENT FOR STORAGE OPERATIONS

April 1, 2023

1. General

- A. This procedure describes a standardized method for defining the data to be reviewed for the risk management well integrity model.
- B. This procedure addresses API RP 1171 8.7.4.
- C. This procedure will also define the frequency that the risk model shall be reviewed and evaluated referenced in API 1171 8.7.2, and 8.4.2, and it will define the records retention schedule referenced in API 1171 8.8.

2. Reference

- A. API RP 1171 Section 8.7.4 (pg. 35)

3. Timeline

- A. Both the risk model and the third party damage prevention model for each of Ameren's 12 storage fields shall be reviewed once per calendar year not to exceed fifteen (15) months
- B. Updates can be made more regularly, but the data for each field shall be analyzed each calendar year at intervals not exceeding fifteen (15) months.
- C. The records retention schedule defined in API 1171 8.8 shall also be reviewed and filed each calendar year at intervals not exceeding fifteen (15) months.
- D. Records shall be retained for the life of the field plus one year.

4. Data to be Reviewed

- A. The expected data to be reviewed is as follows:
 - (1) Corrosion log dates, type of corrosion log, wall loss value, and depth of wall loss.
 - (2) The installation or removal of tubing and/or a packer.
 - (3) The installation or removal of a surface controlled subsurface safety valve.
 - (4) The permit status change of any well.
 - (5) Any structures or roads within the wellhead safety zone of a well that have been added or removed.
 - (6) Any new wells drilled need to be added to the risk model.
 - (7) Annulus pressures for each well shall be updated
 - (8) Cement Bond Log data and cement tops shall be updated.
 - (9) The absolute open flow potential of a well shall be updated if a well was flow tested.
 - (10) H²S levels shall be updated in the risk model.
 - (11) The **Third-Party Damage Prevention Risk Model** shall be updated.
 - (12) Inventory analysis and third-party drilling shall be re-evaluated.

UNCONTROLLED IF PRINTED

(13) Any wells plugged and abandoned shall be updated in the risk model.

5. Documentation

A. All values for each storage field shall be documented in the designated risk model column for each well and stored electronically.

Document Rescission

SECT 8.7.4 Risk Management for Storage Operations: Risk Assessment Procedures, May 15, 2022

Revision Notes

Location of Changes	Summary of Changes
Subsection 4. A. (11)	Updated: Third Party Damage Prevention Risk Model
Subsection 4. A. (13)	New – Any wells plugged and abandoned shall be updated in the risk model.

RISK MANAGEMENT FOR STORAGE OPERATIONS
SECT 8.8 - Recordkeeping

October 15, 2018

1. General

- A. This section describes the minimum requirements for recordkeeping of the risk management records.
- B. The operator shall develop a risk management records retention schedule and management plan.
- C. This section addresses API RP 1171 8.8.

2. Reference

- A. API RP 1171 Section 8.8 (pg. 35)

3. Recordkeeping

- A. The risk management records retention schedule and management plan is defined in [SECT 8.7.4](#).

4. Documentation

- A. The risk management program for each of Ameren's storage fields is stored electronically.
- B. The data collection and integration process to evaluate risk for each of Ameren's gas storage wells can be viewed electronically.
- C. Each of the 12 storage fields has an individual risk management program; each risk management program shall be reviewed and reassessed as described in [SECT 8.7.4](#), documented in the 8.8 recordkeeping document and saved electronically.

RISK MANAGEMENT FOR STORAGE OPERATIONS
SECT 8.20 - Forms and Reference Materials

April 1, 2021

Listed below are forms supporting this section of the Gas Operating & Maintenance Plan.
Click on the links to view the documents.

Forms

Supersedes: October 1, 2019

UNCONTROLLED IF PRINTED

SECT 9 - Integrity Demonstration, Verification and Monitoring Practices

INTEGRITY DEMONSTRATION, VERIFICATION AND MONITORING PRACTICES October 15, 2018

SECT 9.0 Table of Contents

Procedures

Overview

[SECT 9.2](#)

1. General
2. Reference
3. Integrity Maintenance
4. Risk Based Evaluation
5. Documentation

Well Integrity Evaluation

[SECT 9.3.1](#)

1. General
2. Reference
3. Evaluation Requirements
4. Documentation

Well Integrity Monitoring

[SECT 9.3.2](#)

1. General
2. Reference
3. Methodology
4. Documentation

Recordkeeping

[SECT 9.8](#)

1. General
2. Reference
3. Retention
4. Documentation

Forms and Reference Materials

[SECT 9.20](#)

Forms

1. Form 932-2 Annual Sub-Surface Safety Valve Tests

UNCONTROLLED IF PRINTED

INTEGRITY DEMONSTRATION, VERIFICATION AND MONITORING PRACTICES October 15, 2018
SECT 9.2 - Overview

1. General

- A. This section describes the minimum requirements for integrity maintenance and risk-based evaluations.
- B. This section addresses API RP 1171 9.2

2. Reference

- A. API RP 1171 Section 9.2

3. Integrity Maintenance

- A. The operator shall maintain functional integrity of storage wells and reservoirs. Storage wells and reservoirs can have different characteristics resulting in unique requirements in approaching integrity demonstration, verification, and monitoring.

4. Risk-Based Evaluation

- A. Risk assessments shall be used as a basis for developing the integrity demonstration, verification, and monitoring tasks and evaluation their frequency requirements.

5. Documentation

- A. The risk management program for each of Ameren's storage fields is stored electronically.
- B. Each of the 12 storage fields has an individual risk management program. Each risk management program shall be reviewed and reassessed as described in [SECT 8.7.4](#).

INTEGRITY DEMONSTRATION, VERIFICATION AND MONITORING PRACTICES

April 1,
2020

SECT 9.3.2 - Well Integrity Monitoring

1. General

- A. This section describes the minimum requirement for well integrity monitoring.
- B. This section addresses API RP 1171 9.3.2

2. Reference

- A. API RP 1171 Section 9.3.2 (pg. 36-37)

3. Monitoring Requirements

- A. The operator shall monitor for the presence of annulus gas by measuring and recording annular pressure and/or annular gas flow, as outlined in the Annulus Pressure Monitoring Form, two times per calendar year, maximum interval of 7-1/2 months.
- B. The operator shall evaluate each annular gas occurrence that exceeds operator defined threshold levels determined from well integrity evaluation and from risk assessment.
- C. The operator shall visually inspect each wellhead assembly for leaks one time per calendar year maximum interval 15 months.
- D. The operator shall test the operation of the master valve and wellhead pipeline isolation valve for proper function and ability to isolate the well one time per calendar year, maximum interval of 15 months. The valves shall be maintained, repaired, or replaced in accordance with the operator's valve maintenance program for isolation valves.
- E. Surface and subsurface safety valve systems, where installed, shall be function tested one time per calendar year, maximum interval of 15 months. The tests shall be conducted in accordance with manufacturer's recommendations and the operator's procedures. A closed storage well safety valve system shall be manually reopened at the site of the valve after an inspection and not opened from a remote location.
- F. Well site inspections at locations with well access roads shall be performed one time per calendar month, maximum interval of 1-1/2 months. Well site inspections for locations without well access roads shall be performed four times per calendar year, maximum interval of 4-1/2 months.

4. Documentation

- A. Form 932-1A
- B. As defined in API RP 90-2.
- C. Reference Annual Leak Survey
- D. Form 932-1D
- E. SCSSSV form 932-2

Supersedes: October 1, 2019

UNCONTROLLED IF PRINTED

INTEGRITY DEMONSTRATION, VERIFICATION AND MONITORING PRACTICES October 15, 2018
SECT 9.3.1 - Well Integrity Evaluation

1. General

- A. This section describes the minimum requirement for well integrity evaluation.
- B. Wells to evaluate are both company owned and third party.
- C. This section addresses API RP 1171 9.3.1

2. Reference

- A. API RP 1171 Section 9.3.1 (pg. 36)

3. Evaluation Requirements

- A. Operator shall evaluate mechanical integrity of each active well that penetrates the storage zone and buffer zone or area of influence by storage operations.
- B. Operator shall request well integrity evaluation data for third-party well owner/operators following the frequency established using conclusions from the initial evaluation.
- C. Active well mechanical integrity evaluations shall include initial and subsequent evaluations as determined using the risk assessment and the information derived from the initial evaluation.

4. Documentation

- A. All mechanical integrity evaluation will be stored electronically.
- B. Reference letter and certified mail receipt.
- C. Well mechanical integrity evaluations will be assessed through a risk model.

INTEGRITY DEMONSTRATION, VERIFICATION AND MONITORING PRACTICES
SECT 9.8 - Recordkeeping

October 1,
2019

1. General

- A. This section describes the minimum requirements for the documentation and retention of records.
- B. This section addresses API RP 1171 9.8 and API RP 1171 11.2.4

2. Reference

- A. API RP 1171 Section 9.8 (pg. 40)

3. Retention

- A. The operator shall maintain records of storage inventory assessments for the life of the facility.
- B. The operator shall maintain all necessary well records for the life of the field plus one year.
- C. The operator should retain records necessary to properly administer the procedures and establish retention requirements for specific records.
- D. Inspections, tests, patrols, or analyses shall be documented according to the operator's procedures.

4. Documentation

- A. All evaluations shall be stored electronically.

Supersedes: October 15, 2018

INTEGRITY DEMONSTRATION, VERIFICATION AND MONITORING PRACTICES
SECT 9.20 - Forms and Reference Materials

April 1,
2021

Listed below are forms supporting this section of the Gas Operating & Maintenance Plan.
Click on the links to view the documents.

Forms

SECT 10 - Site Security, Safety, Inspections and Emergency Preparedness and Response

SITE SECURITY, SAFETY, INSPECTIONS AND EMERGENCY PREPAREDNESS AND RESPONSE April 1, 2021

SECT 10.0 - Table of Contents

Procedures

Site Security and Safety

[SECT 10.2](#)

1. General
2. Reference
3. Evaluation Requirements
4. Documentation

Signage

[SECT 10.4](#)

1. General
2. Reference
3. Signage Information
4. Illinois State Requirements

Emergency Preparedness and Response

[SECT 10.6](#)

1. General
2. Reference
3. Emergency Preparedness and Response Plan
4. Training

Blowout Contingency Plan

[SECT 10.6.3](#)

1. General
2. Reference
3. Blowout Contingency Plan
4. Blowout Contingency Plan Sources

Supersedes: October 15, 2018

SITE SECURITY, SAFETY, INSPECTIONS AND EMERGENCY PREPARED-
NESS AND RESPONSE
SECT 10.2 - Site Security and Safety

October 1,
2021

1. General

A. These sections describe the minimum requirements for assessment and monitoring of site security and safety, and ingress and egress. These requirements are site specific and vary based on local conditions, such as terrain, land use, and environment of areas adjacent to the wells.

B. This section addresses API RP 1171 10.2

2. Reference

A. API RP 1171 Section 10.2 General (pg. 40)

3. Evaluation Requirements

A. The operator should maintain a process to limit access to storage wells during drilling, workover, operation, and abandonment activities.

B. The operator should evaluate local and site-specific conditions in developing the security measures and may include requirements for: barricades such as bollards, jersey barriers, or concrete impediments; windsocks; wellhead enclosures; valve handles removed, or valves secured; and other means of preventing unauthorized entry or operation of storage facilities.

C. The operator may employ additional measure to enhance site security and safety based on an analysis of the site-specific factors.

D. Each well is evaluated in the Third Party Damage Prevention Risk Model

4. Documentation

A. Third Party Damage Prevention Risk Model

SITE SECURITY, SAFETY, INSPECTIONS AND EMERGENCY PREPARED-
NESS AND RESPONSE
SECT 10.4 - Signage

October 15,
2018

1. General

- A. This section describes the minimum requirements for signage at the well site.
- B. This section addresses API RP 1171 10.4

2. Reference

- A. API RP 1171 Section 10.4

3. Signage Information

A. The operator shall install permanent weatherproof signage at each well site for identification purposes. Signage should contain the following information, at a minimum.

- (1) Storage facility name, well name, and/or identification number
- (2) Operator name; and
- (3) Operator's 24 hour emergency contact number

B. The operator can add other information or signage to enhance site security and safety; such as applicable location information or warnings for areas containing potentially hazardous, flammable, or noxious vapors, etc.

4. Illinois State Requirements

- A. Illinois Administrative Code 62 - Section 240.805 Lease and Well Identification

SITE SECURITY, SAFETY, INSPECTIONS AND EMERGENCY PREPAREDNESS AND RESPONSE April 1, 2023

SECT 10.6 - Emergency Preparedness and Response

1. General

A. This section describes the minimum requirements for emergency preparedness and response plan at the well site and facilities.

B. This requirement is a result of API RP 1171 10.6

2. Reference

A. API RP 1171 Section 10.6

B. EMER 2.11 Gas Storage

3. Emergency Preparedness and Response Plan

A. For site security and safety, the operator shall develop and implement a structured emergency preparedness and response plan in order to:

- (1) Address accidental releases
- (2) Equipment failure
- (3) Natural disasters
- (4) Third party emergencies

B. The operator should integrate natural gas storage emergency procedures with regulatory required procedures covering pipeline facilities rather than creating storage-specific documents.

C. The Emergency Preparedness and Response plan well-specific information can be updated as needed, and the plan is reviewed once per calendar year not to exceed 15 months for effectiveness of existing procedures.

D. The emergency preparedness and response plan for Ameren's storage fields is located on the Gas Storage SharePoint site or electronic equivalent.

4. Training

A. Storage operations and applicable staff shall receive training in the use of the emergency preparedness/response plan once per calendar year, maximum interval of 15 months and training will be documented electronically.

B. The training can include mock drills and participation in table-top exercises and CBT modules.

C. The table-top exercises or mock drills can include civil emergency responders to enhance understanding and successful incident response.

D. Personnel not present for annual training shall cover training material and document electronically.

Document Rescission

SECT 10.6 Site Security, Safety, Inspection and Emergency Preparedness and Response, April 1, 2021

Revision Notes

Location of Changes	Summary of Changes
2. Reference	Added – EMER 2.11 Gas Storage

SITE SECURITY, SAFETY, INSPECTIONS AND EMERGENCY PREPARED-
NESS AND RESPONSE
SECT 10.6.3 - Blowout Contingency Plan

October 15,
2018

1. General

- A. The operator shall have a blowout contingency plan in place.
- B. These requirements addresses API RP 1171 10.6.3
- C. The operator can consult with well control experts in developing a blowout contingency plan.

2. Reference

- A. API RP 1171 Section 10.6.3

3. Blowout Contingency Plan

- A. A blowout contingency plan is company specific and should identify:
 - (1) The procedures
 - (2) Equipment
 - (3) Personnel needed to avoid or respond to a loss of well control situation

4. Blowout Contingency Plan Sources

- A. The blowout contingency plan for Ameren's storage fields is stored electronically.
- B. The specifications and processes used in the data collection and integration process to evaluate the blowout contingency plan for each of Ameren's gas storage wells can be viewed electronically.
- C. All of the information stated in 10.6.3 will be used to determine susceptibility to threat and hazard-related events and to assess threat and hazard interaction.
- D. Each of the 12 storage fields has an data gathered assessment by well control experts; each storage field shall be reviewed and reassessed as described in procedure stored electronically.

SECT 11 - Procedures and Training

PROCEDURES AND TRAINING

October 15, 2018

SECT 11.0 - Table of Contents

Procedures

Construction, Operations and Maintenance Procedures

[SECT 11.2.1](#)

1. General
2. Reference
3. Procedures

Emergency Plans

[SECT 11.4](#)

1. General
2. Reference
3. Plan Effectiveness

Interaction With Control Room

[SECT 11.7](#)

1. General
2. Reference
3. Interaction Requirements
4. Procedures
5. Documentation

Safety and Environmental Programs

[SECT 11.9](#)

1. General
2. Reference
3. Fracture Stimulation

Management of Change

[SECT 11.11](#)

1. General
2. Reference
3. Scope
4. Documentation

Records

[SECT 11.13](#)

1. General

UNCONTROLLED IF PRINTED

2. Reference
3. Records Documentation
4. Training Records
5. Retention
6. Documentation

Forms and Reference Materials

[SECT 11.20](#)

Forms

1. Form 11.11.1 Management of Change

PROCEDURES AND TRAINING

October 15, 2018

SECT 11.2.1 - Construction, Operations and Maintenance Procedures

1. General

A. This section describes the minimum requirement for construction, operation, and maintenance procedures.

2. Reference

A. API RP 1171 Section 11.2.1

3. Procedures

A. Operator shall develop and follow procedures for the construction, operation, and maintenance of natural gas storage wells and reservoirs to establish and maintain the functional integrity. When practicable, the operator's procedures should incorporate applicable industry recommended practices that promote personal and process safety, resource conservation, environmental stewardship, mechanical integrity, and reliable performance.

B. Current procedures shall be available and readily accessible to operations, maintenance, and storage personnel. Procedures may in paper or electronic format.

PROCEDURES AND TRAINING
SECT 11.4 - Emergency Plans

October 15, 2018

1. General

A. This document describes emergency preparedness/response and blowout contingency plans referenced in [SECT 10.6](#).

B. This section addressed API RP 1171 11.4.

2. Reference

A. API RP 1171 Section 11.7.4

B. API RP 1171 Section 10.6

3. Plan Effectiveness

A. The operator shall establish a program to determine operator familiarity with emergency plans and procedures and periodic testing of the effectiveness of the plan in accordance with [SECT 10.6](#).

PROCEDURES AND TRAINING
SECT 11.7 - Interaction with Control Room

May 15, 2022

1. General

- A. This section describes the guidelines for Storage communication with the Control Room.
- B. These requirements address API RP 1171 Section 11.7.

2. Reference

- A. API RP 1171 Section 11.7.1 and Section 11.7.2

3. Interaction Requirements

- A. Storage personnel shall be responsible for preparing and communicating guidelines for maintaining reservoir and well functional integrity.

4. Procedures

A. Preparing and Communicating

(1) The Reservoir Group:

(a) Prepare and send monthly injection and/or withdraw schedule that reflect estimated start and end dates, planned outages (whenever possible), estimated monthly targets.

(b) Prepare and send weekly planners that will include minimum, maximum, and target rates for each Gas Storage Field with comments for any upcoming work that will hinder flow capability.

(c) Participate in the weekly planning call with Gas Control and Gas Supply

(2) Under normal flow conditions, the field supervisors and operators will have the authority for initiating flow, operating, and shutting in natural gas storage facilities according to the schedules and targets set by the reservoir group.

(3) Under abnormal and emergency conditions, the field supervisors and operators will have the authority to initiating flow, operating and shutting in natural gas storage facilities as dictated by the O&M section for Emergency Plan.

5. Documentation

A. Documented electronically through insight Control Room Management Team Training course.

B. Monthly injection/withdrawal schedules documented electronically

C. Weekly gas planning spreadsheets documented electronically

Supersedes: October 15, 2018

UNCONTROLLED IF PRINTED

PROCEDURES AND TRAINING
SECT 11.9 - Safety and Environmental Programs

October 15, 2018

1. General

- A. This section describes the minimum requirements for developing safety and environmental programs.
- B. This section addresses API RP 1171 11.9.1

2. Reference

- A. API RP 1171 Section 11.9.1
- B. Ameren Safety Manual
- C. Ameren O&M Manual

3. Scope of Procedures

- A. The operator shall develop programs incorporating safeguards to the environment, site security, and safety and health into storage design, construction, and operations.

4. Documentation

- A. Pre-Job Safety Briefing Form
- B. Emergency Manual
- C. Operator Mock Emergency Drills
- D. Reservoir Wild Well Control Class/Certification

PROCEDURES AND TRAINING
SECT 11.11 - Management of Change

October 15, 2018

1. General

A. This section describes the minimum requirements for developing Management of Change processes and procedures.

B. This section address API RP 11.11.

2. Reference

A. API RP 1171 Section 11.11

3. Scope

A. Revisions of procedures and processes is an acceptable practice, but the operator shall require changes to be accomplished in a controlled manner.

B. The program documentation, framework, and procedures shall be revised before the change can be implemented. Not all changes need to be approved through a formal MOC process. Some changes are expected and may not be subject to a formal change control process.

4. Documentation

A. Form 11.11.1 to be stored electronically

PROCEDURES AND TRAINING
SECT 11.13 - Records

October 15, 2018

1. General

A. This section describes maintaining records as required in section 11 (Procedure and Training).

B. This section addresses API RP 1171 11.13

2. Reference

A. API RP 1171 Section 11.13

3. Records Documentation

A. The operator shall maintain records to document establishment of and compliance with procedures as required in Section 11 (Procedures and Training).

B. Records may be kept in an appropriate format (paper or electronic). The integrity of the records, especially electronic, should be verifiable. Records should include superseded procedures.

4. Training Records

A. The operator shall maintain records that demonstrates compliance with this subsection.

5. Retention

A. The operator shall establish retention intervals for records that meet regulatory requirements; where no regulatory requirements exist, retention intervals should be determined by the operator.

B. Retention rate and intervals are addressed in Ameren Record Retention program.

6. Documentation

A. All training documented in Insight.

PROCEDURES AND TRAINING
SECT 11.20 - Forms and Reference Materials

April 1, 2021

Listed below are forms supporting this section of the Gas Operating & Maintenance Plan.
Click on the links to view the documents.

Forms

Summary

[Click here to see this page in full context](#)

CHANGE SUMMARY

April 1, 2023

Complete Change Summary			
Document	Change Summary	Previous Date Document	Current Document Dated
ACIG 1	<p>Requirements</p> <p>4.2 Mechanical Sparking and Electric Arcing</p> <p>4.2.1 Revised – Where possible of accidental ignition of a gas-in-air mixture exists, use only flashlights, work lights, tools, equipment and communication devices that are labelled or certified as intrinsically safe and approved for use in a Class 1 Division 1 hazardous environment.</p> <p>1. Class 1 the environment contains flammable gases, vapors, and liquids</p> <p>2. Division 1 an environment where ignitable gases, vapors, or liquids can exist under normal conditions, maintenance work, or because of leakage.</p> <p>The devices that were listed in the tables were not 100% intrinsically safe so Tables have been removed. Language was modified to use only tools, equipment, and devices that are labelled intrinsically safe for use in Class 1 Division 1 hazardous environment.</p> <p>4.2.2 – Removed – This includes the use of devices in Table 2</p> <p>Table 2 was removed so this reference is not needed.</p> <p>4.3 Static Electricity Arcing</p> <p>4.3.1 – Added "steel" - It is steel pipe that requires an electric bond when cutting the pipe.</p> <p>4.3.2 Grammatical revision – Ground the squeeze-off tool prior to squeezing off PE pipe, See POLY 2.2 Subsection 5.1 Before Start-</p>	October 1, 2021	April 1, 2023

	<p>ing Squeeze-off, for eliminating external static charge on 1-1/4 inches PE pipe and larger.</p> <p>Rearranged wording and improve reference link.</p>		
<u>ACIG 2</u>	<p>Work Area Protection</p> <p>Throughout document updated EXCV 2.9. for EXCV 2.09.</p> <p>7.0 Working with Plastic Pipe</p> <p>7.1 New – Ground squeeze-off tool prior to squeezing PE pipe.</p> <p>Reminder that squeeze-off tool must be ground before beginning the squeeze.</p> <p>7.2 Revised – Refer to POLY 2.2 Subsection 5.1 Before Starting Squeeze-off for additional steps for eliminating external static charge on 1-1/4 inches PE pipe and larger.</p> <p>7.3 NOTE – Removed the note that soapy rags are not required on above-ground squeezers.</p> <p>Avoiding potential inconsistencies in ways to eliminate external static by replacing the list with a reference link to POLY 2.2 Subsection 5.1 Before Starting Squeeze-Off. This subsection lists the ways to eliminate the external static.</p>	October 1, 2021	April 1, 2023
<u>BORE 2.1</u>	<p>Boring Operations and Pipe Installation</p> <p>4.0 Boring Operations</p> <p>4.2 Boring Safety</p> <p>4.2.3 Since boring operations may encounter an energized electric cable</p> <p>5. Corrected language – During work in muddy or wet conditions, rubber insulated EH-rated boots (either over-boots or safety-toed boots) shall be worn.</p> <p>This is the language in the Subsurface Utility Protection section of the AIC Safety Manual.</p> <p>4.3 Prior to Beginning Operations</p> <p>4.3.2 – "The Subsurface Utility Protection section" of the AIC Field Safety Manual replaces "provision of Section 33.4".</p> <p>The new Field Safety Manual will have a different section number for Subsurface Utility Protection. Sr Safety Specialists recommending referencing the title of a section rather than a section number which are subject to change with updates.</p> <p>7.0 Directional Drilling</p> <p>7.7 Revise – Begin boring by drilling the pilot hole, mark the bore head progression with spray paint.</p> <p>Marking the bore head progression was missing in the current procedures.</p> <p>7.13 – Added NOTE: The terms and conditions listed in a required boring permit may limit the back-reamer size.</p> <p>Railroad boring permits are reported to limit the back-reamer size to less than the AIC's recommended 1.5 times the pipe's nominal diameter. Typical the limitation is one or two pipe sizes larger than the pipe being installed.</p> <p>9.0 Pipe Installation</p>	May 15, 2022	April 1, 2023

	<p>9.1 General</p> <p>9.1.5 – New – Completed pipe installations shall be back flagged in accordance with DAMG 1 Section 11.0 Back-Flagging.</p> <p>SMR Team felt reference to back flagging the completed installation should be included in the BORE 2.1 eventhough it is referenced in MAIN 1 and SERV 1.</p>		
<p><u>CORR 1</u></p>	<p>Requirements</p> <p>16.0 Painting Pipeline Facilities</p> <p>16.1.1 – Revised- All uncoated new above grade facilities should be cleaned and coated with an approved coating at time of installation. If not possible, Gas Supervisor or Operations Coordinator should schedule it to be done. See CORR 2.3 Section 10.0 Approved Paint Specification and Appendix J.</p> <p>Language was expanded so that this subsection could be referenced in the METR sections where painting meters sets is addressed. In addition, clarifies that if the painting is not performed at time of installation, the Gas Supervisor or Operation Coordinator should schedule the facility for painting. Maximo does not create work orders for facilities needing paint.</p> <p>Appendix A-2 Competition of Buried Pipe Examination Form</p> <p>1. F. A Buried Pipe Examination form should not be performed when:</p> <p>(4) New – Pipe is located in a vault or pit.</p> <p>Clarification that an exposed pipe in a vault or pit does not require completion of Buried Pipe Examination form.</p>	<p>October 1, 2022</p>	<p>April 1, 2023</p>
<p><u>CORR 2.3</u></p>	<p>Coatings</p> <p>4.0 Approved Coatings</p> <p>4.1 New Pipe Installation</p> <p>4.1.2 Directional Drilling</p> <p>4. Installation instructions</p> <p>4 b. Moisture Cured Wrap (MCW)</p> <p>4 b. (i) – Trenton MC110 Outerwrap or Denso Glass Outerwrap – See Appendix I-5.</p> <p>Updated Trenton MC110 Outerwrap replaces Trenton MC Outerwrap.</p> <p>4.5 Fittings</p> <p>4.5.2 – New – Coating on below grade valves provided by the valve manufacturer, valve supplier, or fabricating shop can be used in-lieu of AIC approved coating if approved by the Superintendent of Corrosion Control.</p> <p>Allows for approved precoated below grade valves to be installed without any additional coating applied.</p> <p>4.6 Soil-t0-Air Interface Zone</p> <p>4.6.6 NOTE – Added – MCW shall extend a minimum of 2 inches passed the other coating material per Trenton MC110 Outerwrap Application Instructions. See CORR 3.</p> <p>Emphasis to ensure there is a good seal between the outerwrap and the pipe.</p> <p>6.0 Approved Cold Applied Tape</p>	<p>October 1, 2022</p>	<p>April 1, 2023 April 1, 2023</p>

6.1 – Removed "exposed to soil". No wrinkles in the cold applied tape shall be left. All wrinkles must be cut out and retaped.

Appendix B Coating Repair

B-1 & B-2 - Throughout "inches" replaced " or inch

Appendix G Moisture Cured Wrap

Updated Trenton MC110 Outerwrap

Appendix H General Wrapping Instructions

"inches" replaced inch

4. A. – Added "cold applied" to wax tape.

Clarify that cold applied tape and cold applied wax tape are two separate products.

Appendix I Specific Coatings

Appendix I-1 Tapecoat 20

2. C. (2) - "inches" replaced inch

Appendix I-3 Tapecoat H35

1. B. Revised - No wrinkles in cold tape shall be left. Removed "exposed to soil"

3. A. - "inches" replaced inch

Appendix I-4 Denso Butyl 35

1. B. Revised - No wrinkles in cold tape shall be left. Removed "exposed to soil"

There are to be no wrinkles left in cold tape wrap regardless if it above grade or below grade, Wrinkles allow water to get trapped.

Appendix I-5 Moisture Cured Wrap

1. C. - "inches" replaced inch

2. A. - "inches" replaced inch

2. Application Procedures for Girth Welds.

Rearranged some of the steps and split some of original steps into individual line items.

3. Completion and Curing of MCW Wrap

A. (1) – Capitalized "OR"

C. – Moved 1st sentence into a NOTE.

4. Application Procedures at Soil Air Interface Zone

4. B – Reformatted into individual steps.

4. H. – Separated from 4. G.

4. L. – Separated from 4. K.

4. N. – Removed "as stated above"

5. Moisture Cured Wrap Coverage Table

NOTE below table – "inches" replaced inch

Appendix I-6 Tapecoat TC Color Coat

3. A. Table, Note - "inches" replaced inch

Appendix 1-7 Trenton #2 Wax Tape

3. A. - "inches" replaced inch

3. B –"lbs." replaced lb.

Appendix J Approved Paints

Added – Tnemec Series 1095 paint

UNCONTROLLED IF PRINTED

	The Series 1095 is an approved alternative for the Tnemec Series 73 paint which is in short supply		
<u>CORR 3</u>	<p>Forms and Reference Materials</p> <p>Added:</p> <p>Tnemec Endura Shield Series 1095 paint</p> <p>Tnemec Omnithane Series 1 Primer</p>	October 1, 2020	April 1, 2023
<u>DAMG 0</u>	<p>Table of Contents</p> <p>DAMG 1</p> <p>New section 11.0 Back-Flagging</p>	October 1, 2020	April 1, 2023
<u>DAMG 1</u>	<p>Requirements</p> <p>2.0 Scope</p> <p>Added Section 11.0 Back Flagging</p> <p>11.0 Back Flagging – New section</p> <p>Moved language from previous Paragraph 5.1.4 into new section.</p> <p>This emphasizes the importance of back flagging newly installed facilities.</p> <p>13.0 Records and Reports</p> <p>13.4 – Removed – Damage Prevention Incident Report was removed earlier from the O&M DAMG Forms and Reference Materials section so the information is no longer valid</p>	October 1, 2022	April 1, 2023
<u>EMER 2.2</u>	<p>Dispatch Center</p> <p>7.0 Cold Weather Electric Outage and Restoring Service</p> <p>7.3 Contact Lists for GTS and Gas Planning</p> <p>Table 2 Gas Planning – Updated contact information</p>	October 1, 2022	April 1, 2023
<u>EMER 2.4.4</u>	<p>Dispatched to Gas in Sewer – Hazardous Condition</p> <p>1.3 Sample the environment below the rim of the manhole cover with CGI.</p> <p>1.3.1 –Replaced (See Figure 1) with See LEAK 3 for ethane identifier instrument instructions.</p> <p>Removed Figure 1 – Heath EI-4 Ethane Identifier.</p> <p>The Heath EI-4 is no longer being used by Operations. The Sensit IRED is now being used. To avoid future O&M changes if a different ethane identifier is being used, the reference to LEAK 3 was added. This is where the instructions for approved leak investigation instruments are being maintained.</p> <p>1.3.2 – Grammatical – A hazardous condition exists if CGI reads 30% LEL (1.5% gas-in-air) or greater.</p>	October 1, 2021	April 1, 2023
<u>EMER 2.4.6</u>	<p>Gas Field Personnel Dispatched to Non-Gas Related Fire, Ignition, or Explosion</p> <p>1.4 Note – Revised – If a determination has not been made, advise your Gas Supervisor or Duty Supervisor and request guidance if follow-up action is necessary.</p>	October 1, 2022	April 1, 2023

UNCONTROLLED IF PRINTED

	<p>Previous language said to handle as a Gas Related Fire which caused confusion because procedures for Gas Related Fire are very detailed which would require more resources. Professional judgment of the gas field personnel and the Gas Supervisor should be able to determine what, if any, additional action should be performed.</p> <p>1.5.3 If the Fire Department has shut-off the gas.....</p> <p>2. Check to see what valves are present and which one is or can be shut off</p> <p>2 a. Incorporated 2 a. (i) – If a customer convenience valve (CCV) is present, it can be used to shut-off gas to the structure. The meter valve can either be turned back on or left off.</p> <p>2 a. (ii) – Removed checking to make sure gas is not passing through the closed CCV.</p> <p>Since checking the closed CCV is not required in any other EMER or LEAK section, the SMR team requested it be removed.</p>		
<u>EMER 3</u>	<p>Forms and Reference Materials</p> <p>Updated Electric Cold Load Restoration Policy</p>	October 1, 2022	April 1, 2023
<u>INCD 1</u>	<p>Requirements</p> <p>10.0 Gas Compliance Responsibilities</p> <p>10.2 Determine if the Potential Incident meets reporting criteria of: Formatting correction, this item should have been Subsection 10.2.</p> <p>10.3 Report a Natural Gas Incident to PHMSA and ICC</p> <p>10.3.3 The 30-Day Report</p> <p>2. New - If additional relevant information is obtained after submittal of the 30-day report, a supplemental report shall be submitted as deemed necessary. The supplemental report shall have a clear reference by date and subject to the original report.</p> <p>Current O&M was missing a reference to submitting a Supplemental Report as requirement in §191.9 Distribution System Incident Report and §191.15 Transmission and Gas Storage Incident Report</p> <p>Appendix D Ameren Corporate and AIC Contacts</p> <p>Table 5 – New</p> <p>Contact information for the Integrated Operation Center (IOC) to obtain AMI readings.</p> <p>GSE requested the contact phone number be added to Incident Reporting section. It is included in the Investigation of Incident also.</p>	October 1, 2022	April 1, 2023
<u>INCD 2</u>	<p>Forms and Reference Materials</p> <p>Forms:</p> <p>Updated – Potential Incident Report Form</p>	October 1, 2022	April 1, 2023
<u>LEAK 0</u>	<p>Table of Contents</p> <p>LEAK 2.5 – Leak Detection Equipment – Name change</p> <p>LEAK 2.5:</p>	October 1, 2022	April 1, 2023

	<p>Removed – Gas-Trac section, Optical Methane section. Renamed: Remote Methane Detector (RMD) section The Gas-Trac and Optical Methane Detector instruments are not being used by AIC operations. Corrected Section 10,0 – Laser Spectroscopy – Advanced Mobile Leak Detection (AML D)</p>		
LEAK 2.2	<p>Outdoor Investigation 6.0 Below-Grade Gas Facilities 6.5 Ground/surface conditions that do not allow accurate pinpointing of gas leak. 6.5.2 – Added Reference Link – See PURG 3 for Vapor Extraction Unit (VEU) manufacturer's instructions. Manufacturer's instructions for the MBW VEU and the associated iTrans 2 Gas Sensor have been moved the PURG 3 section.</p>	October 1, 2022	April 1, 2023
LEAK 2.5	<p>Leak Detection Equipment – Name change 1.0 Purpose – Inserted "leak investigation" since the equipment in this section is used for leak investigation and for leak surveys. 2.0 Scope – Section titles changed due to removal of Gas-Trac and Optical Methane Detection (OMD) sections. Corrected the name of Section 10.0 – Laser Spectroscopy – Advanced Mobile Leak Detection (AML D) Gas-Trac and Optical Methane Detector instruments are not being used by AIC gas personnel. 5.0 Portable Flame Ionization Instrument (FI) 5.4 – Updated reference link – See Section 11.0. 7.0 Gas Detection Instrument 7.8 - Updated reference link – See Section 11.0. With the removal of Gas-Trac and OMD sections, Records in now Section 11.0. Section 8.0 Gas Trac removed. Section 8.0 is now Mobile Flame Ionization Unit (FI) Section 9.0 is now Remote Methane Detector (RMD) 9.1 – Revised – RMD instruments utilize laser technology 9.2 – Revised – RMD instruments can: 9.2.1 Detect methane gas up to 100 feet away. 9.2.2 Be used in conjunction with Walking Leak Survey. 9.2.3 Enable leak surveying of facilities that are difficult to access. Section 10.0 is now Laser Spectroscopy – Advanced Mobile Leak Detection (AML D) 10.9 – Revise LEAK 3 reference to ABB Ability Mobile Gas Leak Detection System (MobileGuard) for manufacturer's instructions. Section 11.0 is now Records Former Section 11.0 Optical Methane Detector (OMD) removed. Operator Qualifications (OQ) Required Removed 1281 – Mobile Gas Leakage Survey – Optical Methane</p>	October 1, 2022	April 1, 2023

<p><u>LEAK 3</u></p>	<p>Forms and Reference Materials</p> <p>Reference Materials:</p> <p>New:</p> <p>Inficon IRwin Operating Instructions</p> <p>Updated:</p> <p>Bascom Turner Gas Rover Operating Manual Heath Detecto-Pak 4 User's Manual Heath Gasurveyor 500 User Handbook Heath Gasurveyor 700 User's Guide Heath RMLD User's Manual Sensit HXG-3 Instruction Manual</p> <p>Removed:</p> <p>Gas-Trac Heath EI-4 Ethane Identifier Manual. Heath EI-5 Ethane Identifier Manual Heath GT Series User Handbook Heath OMD User's Manual Heath RMLD User's Manual Trak-It III CGI Instruction Manual iTrans 2 User Manual MBW Vapor Extraction Unit (VEU) Operator Safety and Service Manual.</p>	<p>May 15, 2022</p>	<p>April 1, 2023</p>
<p><u>MAIN 1</u></p>	<p>Requirements</p> <p>5.0 Cover</p> <p>5.3 – Revised – Where gas carrying fittings are attached to mains, fittings should have a minimum cover of 24 inches.</p> <p>Correction made to an error in the Re-Write October 1, 2020 O&M. Fittings on distribution mains should have a minimum cover of 24 inches to meet the requirements of 192.327(d) not the 30 inches as currently stated in the O&M.</p> <p>5.4 – Added – For additional protection Tuff-N-Nuff (49 22 241) may be used. See Appendix A.</p> <p>5.4.1 - Removed</p> <p>The Safety Wrap material is no longer manufactured. Tuff-N-Nuff is available for added protection when the minimum cover cannot be maintained.</p> <p>17.0 Back-Flagging</p> <p>17.1 – Updated reference DAMG 1 Section 11.0</p> <p>19.0 Records</p> <p>19.2 New - Required geospatial data for AIC's transmission pipelines will be submitted by Transmission Integrity Management (TIMP) personnel to the National Pipeline Mapping System (NPMS) on or before March 15th each year. The submitted data should reflect conditions in the field as of December 31 of the previous year.</p> <p>This is a requirement in § 191.29 that was not included the previous or current O&M.</p>	<p>May 15, 2022</p>	<p>April 1, 2023</p>

<p><u>METR 1</u></p>	<p>Requirements</p> <p>9.0 Painting Meter Set</p> <p>9.1 – Revised – All uncoated piping, fittings, and valves should be cleaned and coated with AIC approved paint at the time of installation in accordance with CORR 1 Subsection 16.1 Painting Pipeline Facilities.</p> <p>Removed regulators and meters. These items should already be painted when installed. Touch-up of these two is covered in Subsection 9.2 Added reference link to CORR 1 Section 16.0 which addresses painting pipeline facilities</p>	<p>October 1, 2022</p>	<p>April 1, 2023</p>
<p><u>METR 2.1</u></p>	<p>Replacement and Retirement</p> <p>10.0 Painting Meter Set</p> <p>10.1 Revised – If above ground piping needs painted, it shall be done in accordance with METR 1 Section 9.0 Painting Meter Sets.</p> <p>Removed 10.2</p> <p>Replaced reference link to METR 1 Section 9.0 Painting Meter Sets. 10.2 contained basically the same language that is in METR 1 Section 9.0.</p>	<p>October 1, 2022</p>	<p>April 1, 2023</p>
<p><u>METR 3.2</u></p>	<p>Regulator Sizing</p> <p>4.0 General</p> <p>4.2 – Grammatical – Gas Tech Engineering (GTE) replaced Gas Tech Services Engineering (GTSE)</p> <p>GTE is used throughout the O&M</p> <p>Appendix C – 5 PSIG Delivery Pressure</p> <p>Added – Contact GTE in the table for 2" Fisher 299H with 3/8" orifice and 1/2" orifice where the minimum distribution pressure is 80 psig or higher. Removed Note (5) that was associated with these regulators</p> <p>Appendix D – 10 PSIG Delivery</p> <p>Added – Contact GTE in the table for:</p> <p>2" Fisher 299H with 1/2" orifice and minimum distribution pressure is 60 psig or higher.</p> <p>2? Fisher 299H with 3/8" orifice and minimum distribution pressure is 80 psig or higher.</p> <p>Remove Note (6) that was associated with these regulators.</p> <p>GTE reevaluated the relief valve requirements for the 2" Fisher 299H and made the above adjustments to the Table. GTE wants to be contacted before the designated regulator is installed to ensure the proper relief valve is also installed.</p> <p>Appendix E – Alternative Regulator Sizing</p> <p>E-1 - 7" w.c. Delivery Pressure</p>	<p>October 1, 2022</p>	<p>April 1, 2023</p>

	<p>Updated Relief Valve associated with:</p> <p>2" Itron B34R with 1/4" orifice – Note (5) - 1" Fisher 289L, 12" tp 40" w.c., set at 14"w.c</p> <p>2: Itron B34R with 3/8" orifice – Note (6) - 2" Fisher 289H, 0.5 to 2.25 lb spring, set 14" w.c. and Note (8)</p> <p>(8) 2" Itron B34R, 3/8" orifice – Do Not exceed 125 psig MAOP Inlet Pressure. (9) 2" Itron B34R, 1/2" orifice – Do Not exceed 75 psig MAOP Inlet Pressure</p> <p>(10) 2" Itron B34R, 5/8" orifice – Do Not exceed 60 psig MAOP Inlet Pressure.</p> <p>E-2 – 2 psig Delivery Pressure</p> <p>Table – Contact GTE was inserted for 2" Itron B34R-2 with 3/8" orifice with 100 psig minimum distribution pressure.</p> <p>GTE reevaluated the 2" Itron B34R and made the above adjustments to the Table.</p> <p>Note (6) – Added Itron</p> <p>E-3 – 5 psig Delivery Pressure</p> <p>Note (3) – Itron replaces Actaris</p> <p>E-4 – 10 psig Delivery Pressure</p> <p>Note (3) – Itron replaces Actaris</p> <p>Grammatical change only</p>		
<p><u>METR 3.3</u></p>	<p>Diaphragm Meter Sets</p> <p>Grammatical correction in the Material List Tables and Installation instructions only; CCV replaces CVV</p> <p>Appendix A through Appendix B – 175/250 Meter</p> <p>Material List – Item 3</p> <p>Installation – Item 1.</p>	<p>October 1, 2022</p>	<p>April 1, 2023</p>
<p><u>ODOR 1</u></p>	<p>Requirements</p> <p>6.0 Odorant Concentration</p> <p>Table 2 Odorant Concentration Levels</p> <p>S-20 – Target Range, Maximum: Changed to 1.5.</p> <p>S-20 – Out of Range: Change to Greater than 1.5.</p> <p>7.0 Monthly Odorization Report</p> <p>7.2.1, Item 1a.- S-20 (80/20) blends: Calculated usage is out of range if less than 0.50 OR greater than 1.5 Lbs/MMSCF.</p> <p>Odorization team recommended changing maximum concentration of S-20 to 1.5 from 1.25. This balances the 0.5 difference between the Minimum and Maximum and will help avoid nuisance alarms at Gas Control</p>	<p>May 15, 2022</p>	<p>April 1, 2023</p>
<p><u>ODOR 2.1</u></p>	<p>Odorant Intensity Sampling and Testing</p>	<p>May 15, 2022</p>	<p>April 1, 2023</p>

UNCONTROLLED IF PRINTED

	<p>6.0 Intensity Test Instruments</p> <p>6.2 – Added the YZ-DTEX Odorant Detection System back as an approved instrument. AIC has 2 approved instruments, Heath Odorator 2 and the YZ-DTEX.</p> <p>The YZ-DTEX was previously approved until Supt GTS decided to standardize on one instrument, Odorator 2. Due to some issues with the Odorator 2 and the long lead time for repairs, Operations feels it necessary to return the YZ-DTEX to approved status.</p> <p>Reference Documents</p> <p>Added: YZ-DTEX DX1000G/L Instruction & Operating Manual.</p>		
<u>ODOR 3</u>	<p>Forms and Reference Materials</p> <p>Reference Materials</p> <p>Added – YZ-DTEX DX1000G/L Instructions & Operating Manual</p>	October 1, 2022	April 1, 2023
<u>QQAL 1</u>	<p>Requirements</p> <p>15.0 Contactors</p> <p>15.3 AIC Gas OQ staff will evaluate Contractor OQ Plans</p> <p>15.3.1 – Energy World Net (EWN) – Removed the other 3 Industry Consortiums previously listed.</p> <p>EWN is the only one AIC will be using to evaluate Contractor OQ Plan</p>	October 1, 2022	April 1, 2023
<u>QQAL 2.1</u>	<p>Covered Tasks List</p> <p>Added:</p> <p>1281 Mobile Gas Leakage Survey: Optical Methane</p> <p>A004 Mobile Gas Leakage Survey: Laser Spectroscopy</p>	October 1, 2022	April 1, 2023
<u>QQAL 2.2</u>	<p>Cover Tasks AOC's</p> <p>Added – A004 Mobile Gas Leakage Survey: Laser Spectroscopy</p>	October 1, 2022	April 1, 2023
<u>PCBH 1</u>	<p>Requirements</p> <p>4.0 General</p> <p>4.5 – "PCB section of the Ameren Illinois (AIC) Safety Manual" replaced "Ameren Safety (AIC) Safety Manual, Section 19.2".</p> <p>This change will eliminate the need to make future O&M changes if the section within the Safety Manual changes. In the soon to be released new Safety Manual, the PCB section number changed.</p> <p>4.8 – "Personal Protective Equipment" replaced "Personnel Protective Equipment".</p> <p>4.9 – "inspected for potential sampling and for disposal of collected equipment" replaced "inspected of sampling and for disposal of collected equipment".</p> <p>6.0 Testing</p> <p>6.5 – "requirements" replaced "is needed"</p> <p>7.0 Disposal</p> <p>7.2 – "regulated waste" replaced "hazards waste"</p> <p>7.3 – Revised – If the analysis shows less than 50 ppm the liquid is considered non-PCB and the associated waste may be handled as a non-hazardous waste material.</p> <p>7.3.2 – Spelling correction – "labeled" replaced "label"</p>	May 15, 2022	April 1, 2023

UNCONTROLLED IF PRINTED

	Above changes updates terminology and corrects spelling and miss used words.		
<u>PMRK 1</u>	<p>Requirements</p> <p>6.0 Placement</p> <p>6.2 – Class 3 and Class 4 locations:</p> <p>Grammatical addition – Inserted "as close". Pipeline markers and/or signs must be placed as close as practical over each transmission line without encroaching on the integrity of the line, unless placement of the pipeline marker or sign is impractical.</p>	October 1, 2020	April 1, 2023
<u>POLY 2.1</u>	<p>Design Pressure</p> <p>Appendix A-1 – PE2708 Pipe</p> <p>Removed 1/2" CTS PE2708 pipe from Stock Coded PE Pipe Table.</p> <p>AIC no longer purchases 1/2" CTS PE2708 pipe. PE4710, HDPE, is used for all 1/2" CTS service lines.</p>	October 1, 2020	April 1, 2023
<u>POLY 2.2</u>	<p>Squeeze Off</p> <p>5.0 Operation</p> <p>5.1 Before Starting Squeeze-Off (Added hyphen)</p> <p>5.1.3 – Updated Ionix Static Suppressor to the low temperature formula (-20°F). New Stock Code 49 22 507).</p> <p>The low temperature formula (-20°F) is more versatile since it can be used at warmer temperatures the same as the standard formula (32°F). The Stock Code for the standard temperature formula has been cancelled.</p> <p>5.1.3 NOTE – New – When using above grade squeeze-off tool refer to Section 6.0 for the exception on the use of a static suppressor or wet rags.</p> <p>NOTE was added to specify that the static suppressor is not needed when using above grade squeeze-off tool.</p> <p>5.2.2 Table 1 – Fractions for minimum distance based on 3 times the pipe outside diameter.</p> <p>Complaints from field personnel and OQ that the whole numbers in the table were not consistent with 3 pipe diameters stated in Paragraph 5.2.2. The 3-times pipe diameter is an ASTM requirement and is included in Performance Pipe's PP801-TN Squeeze-Off.</p>	October 1, 2022	April 1, 2023
<u>POLY 2.5</u>	<p>Electrofusion</p> <p>9.0 Peeling</p> <p>9.5 Peeling</p> <p>9.5.4 Ensure all witness marks have been removed. If marks remain then:</p> <p>Added:</p> <ol style="list-style-type: none"> 1. Peeling at end of pipe: Remove that section of pipe and start over. 2. Peeling within pipe segment: Move to a new location and start over. Tape over the previously peeled section to indicate tapping that section shall be avoided in the future. <p>There were questions raised as what to do if marks remained on a section being peeled for a service tee or high-volume tapping tee.</p>	October 1, 2022	April 1, 2023

	<p>Rather than removing and replacing a section of pipe, the tee location could be moved to another spot. Since the marks remained, the pipe wall thickness would be above the minimum required.</p> <p>Appendix A – Added – Electrofusion fittings listed below are PE4710.</p> <p>Groeбner representative reported that GFCP confirmed their fittings are PE4710</p>		
<u>POLY 4</u>	<p>Forms and Reference Materials</p> <p>Reference Materials –</p> <p>Updated: Innogaz Installation Procedures</p> <p>Added: Supraflow Gas Tap Tee Specifications</p>	October 1, 2022	April 1, 2023
<u>PTST 1</u>	<p>Requirements</p> <p>8.0 Test Recording Methods</p> <p>8.1 The following methods can be used to record ...</p> <p>8.1.1 – Correction – 20% SMYS replaced 30% SMYS.</p> <p>Pressure gauges can be used when testing non-transmission classified or designated facilities. Consistent with requirement shown in testing tables in PTST 1.1. Table D.</p> <p>8.1.2 – Revised – Pressure Recording Device: Refer to PTST 1.1 Appendix D for recording devices required for hydrostatic testing designated transmission or classifies transmission facilities.</p> <ol style="list-style-type: none"> Mechanical pressure chart recorder Electronic chart recorder. Calibrated dead weight tester system. <p>Original Item 4. was placed in a NOTE that applies to both Paragraph 8.1.1 and 8.1.2:</p> <p>NOTE: Gauges or recorders with digital displays should be read and recorded in whole units. Round down readings to the nearest whole psig unit.</p> <p>The requirements for recording pressure tests on designated transmission and classified transmission facilities was moved the PTST 1.1 Appendix D.</p>	October 1, 2022	April 1, 2023
<u>PTST 1.1</u>	<p>Test Pressure and Duration Requirement Tables</p> <p>Appendix D – Steel Mains – All Steel Pipe Sizes Thru 30" With Design MAOP 100 psig or Greater</p> <p>Original D-5 – Removed</p> <p>Information is covered in Notes 3 and 4 below Table D</p> <p>New D-5 - Facilities that are designated as transmission or with a Design MAOP that result in stress of 20% SMYS or higher, a manual pressure chart recorder is required in addition to an electronic pressure recorder or dead weight tester system when recording hydrostatic pressure tests.</p> <p>In order to ensure an accurate and reproducible pressure test on designated or classified transmission facilities, Integrity Management requires a manual pressure chart recorder plus one other recording device.</p> <p>Table D - Design MAOP column:</p>	October 1, 2022	April 1, 2023

	<p>Added "Excluding designated transmission (4) in the ≥ 100 psig AND $< 20\%$ SMYS box.</p> <p>The was added to address pipelines in the storage fields that are classified as transmission even though they are below 20% SMYS.</p> <p>Note on bottom line of Table D: Revised – All pipeline facilities that are designated as transmission or have a Design MAOP at or above 20% SMYS are to be hydrostatically pressure tested whether tested in place or re-tested. Refer to PTST 1 Paragraph 7.1.4 for exceptions.</p> <p>Link to PTST 1 Paragraph 7.1.4 provides an exception for hydrostatic testing of transmission facilities. Current language in Table D "unless otherwise approved" was creating confusion in its meaning.</p> <p>Notes: Added (4) For designated transmission pipe with less than 20% SMYS, the pipe shall meet the requirements shown in Table D for 20% SMYS to less than 30% SMYS.</p> <p>Note (4) replaces the original D-5.</p> <p>Appendix F – Farm Tap, Single Cut Reformatted bottom section of table. Separated: From Main to Outlet and Outlet Service Lines</p> <p>Appendix G – Farm Tap, Double Cut Reformatted bottom section of table. Separated: From Main to Outlet and Outlet Service Lines</p> <p>The Note at the bottom of the table only applied to testing from the main to the outlet of the farm tap.</p>		
<u>PTST 3</u>	<p>Forms and Reference Materials</p> <p>Forms: Added</p> <p>Leak Test Form LTF19 – Fillable</p> <p>Leak & Strength Test Form LSTF19 - Fillable</p> <p>Updated</p> <p>Inspection of ASME Pressure Vessels Form</p>	October 1, 2022	April 1, 2023
<u>PURG 2</u>	<p>Methods</p> <p>7.0 Using an Inert Gas Plug when Purging</p> <p>7.1 – Grammatical – "operates" replaced "operating"</p> <p>9.0 Vacuum Purge/Air Mover</p> <p>9.1 – Added – See PURG 3 for MBW Vapor Extraction Unit (VEU) Manual.</p> <p>15.0 Use of Compression System</p> <p>15.1 – Added – See PURG 3 for ZEVAC Manuals</p>	October 1, 2022	April 1, 2023
<u>PURG 3</u>	<p>Forms and Reference Materials</p> <p>Reference Materials - Added</p> <p>MBW VEU Manual</p> <p>iTrans 2 User Manual</p>	December 15, 2021	April 1, 2023
<u>REPR 0</u>	<p>Table of Contents</p> <p>REPR 1 Requirements</p> <p>Appendices:</p>	December 15, 2021	April 1, 2023

UNCONTROLLED IF PRINTED

	<p>Appendix C – Reinforcing Split Sleeves</p> <p>Removed Dresser since Allen Edwards has been approved as another manufacturer.</p>		
REPR 1	<p>Requirements</p> <p>2.0 Scope</p> <p>Appendix C – Removed Dresser.</p> <p>AIC has approved Allen Edwards for reinforcing sleeves.</p> <p>6.0 Common Repair Considerations – Steel Pipe</p> <p>6.3 Welded Full-Encirclement Reinforcing Split Sleeves</p> <p>Updated title of Subsection.</p> <p>Removed - This section addresses use of the Dresser Style 110 or 220 Reinforcing Split Sleeve. See Appendix C for material specifications.</p> <p>Sentence is not needed especially since AIC has approved another manufacturer.</p> <p>6.5 Composite Wrap Systems</p> <p>6.5.4 – Revised – If composite wrap is determined to be an appropriate repair method, follow the manufacturer's installation instructions.</p> <p>1. Approved composite wrap:</p> <p>1a, Syntho-Glass XT</p> <p>1b. Clock Spring</p> <p>1c. OmegaWrap</p> <p>2 See REPR 3 for:</p> <p>2a. Syntho-Glass XT Engineering Assessment Form and Installation</p> <p>2b. Clock Spring Coil Pass Method Installation Manual</p> <p>2c. Clock Spring Underwater Installation Guide</p> <p>2d. OmegaWrap Installation Procedures</p> <p>Listed AIC's current approved composite wrap systems.</p> <p>Appendices:</p> <p>Appendix C – Reinforcing Split Sleeve – Removed Dresser</p> <p>Appendix A – Header – Reinforcing Sleeve replaced Type B Sleeve (Dresser 110 or 220)</p> <p>Appendix B – Header - Reinforcing Sleeve replaced Type B Sleeve (Dresser 110 or 220)</p> <p>Appendix C – Removed Dresser</p>	December 15, 2021	April 1, 2023
REPR 3	<p>Forms and Reference Materials</p> <p>Reference Materials</p> <p>Updated:</p> <p>CSNRI Clock Spring Coil Pass Method Installation Guide and Checklist</p> <p>CSNRI Clock Spring Product Sheet</p> <p>Added</p> <p>CSNRI A+ Wrap Product Sheet</p> <p>CSNRI Clock Spring Filler & Adhesive Update</p>	December 1, 2020	April 1, 2023

	<p>OmegaWrap Installation Procedures</p>		
<p><u>SERV 1</u></p>	<p>Requirements</p> <p>7.0 Location</p> <p>7.3 Service Risers</p> <p>7.3.3 Added – A plastic sleeve should be installed around newly installed gas risers that are planned to be encased in a hard surface. The sleeve should extend above the hard surface.</p> <p>Provides protection against an adverse reaction between the concrete and the anodeless riser. Also provides a path to an open environment for leaking gas.</p> <p>13.0 Back-Flagging</p> <p>13.1 – Updated reference link to DAMG 1 Section 11.0.</p> <p>Appendix A-3 – Residential Meter Set Locations Restrictions</p> <p>Replace picture with the one in AIC Gas Service brochure.</p> <p>Appendix B-1 – 1/2" PE Service Line, Flex Riser- Installation</p> <p>1. Revise – PE4710 service line is utilized for all 1/2-inch PE service lines with a MAOP of 125 psig or less.</p> <p>Appendix B-1 – 1/2" PE Service Line, Flex Riser- Material Table</p> <p>Eliminated PE2406/PE2708 Table</p> <p>Expanded the PE4710 Table to include the larger service tees that were in the PE2406/PE2708 Table.</p> <p>Removed PE3408 within the tables.</p> <p>Appendix B-2 – 1/2" PE Service Line, Rigid Riser- Installation</p> <p>1. Revise – PE4710 service line is utilized for all 1/2-inch PE service lines with a MAOP of 125 psig or less.</p> <p>Appendix B-2 – 1/2" PE Service Line, Flex Riser- Material Table</p> <p>Eliminated PE2406/PE2708 Table</p> <p>Expanded the PE4710 Table to include the larger service tees that were in the PE2406/PE2708 Table.</p> <p>Removed PE3408 within the Material tables</p> <p>AIC no longer purchases 1/2"CTS PE2406/PE2708 pipe. PE4710 pipe is used for all 1/2"CTS service lines.</p> <p>Appendix B-3 -1" PE Service Line, Flex Riser - Installation</p> <p>1. Updated PE2708 pipe designation for service line</p> <p>2. Revised – PE4710 service line shall be utilized on 1- inch service lines with a MAOP of between 61 and 125 psig. PE4710 can also be installed in systems with MAOP less than 61 psig.</p> <p>Removed PE3408 within the Material tables</p> <p>3. Updated PE4710 pipe designation for service line</p> <p>Appendix B-4 -1" PE Service Line, Rigid Riser - Installation</p> <p>1. Updated PE2708 pipe designation for service line</p> <p>2. Revised – PE4710 service line shall be utilized on 1-inch service lines with a MAOP of between 61 and 125 psig. PE4710 can also be installed in systems with MAOP less than 61 psig.</p>	<p>October 1, 2022</p>	<p>April 1, 2023</p>

	<p>3. Updated PE4710 pipe designation for service line Removed PE3408 within the Material tables Appendix B-5 – 2" PE Service Line, Rigid Riser – Installation</p> <p>1. Updated PE2708 pipe designation for service line. 2. Updated - PE4710 service line shall be utilized on 2-inch service lines with an MAOP of between 61 and 125 psig. PE4710 can also be installed in systems with MAOP less than 61 psig. 3. Updated PE4710 pipe designation for service line.</p> <p>Added Note 10. The EFV shall be installed in accordance with SERV 2.2 Excess Flow Valves of Manual Shut-off Valves Removed PE3408 within the Material tables</p> <p>Updated PE pipe designations, PE2708 and PE4710, to match Performance Pipe's designations</p>		
<p><u>SERV 2.2</u></p>	<p>Excess Flow Valve or Manual Shut-off Valve 4.0 Requirements 4.3 Single small commercial service installed or replaced after April 14, 2017. 4.3.3 – Revised – For branch service, an EFV shall be installed on each service line to a small commercial customer. PHMSA clarified in a recently published FAQ that a EFV is required on each service line of a branch service line to a small commercial customer.</p> <p>4.9 Customer Request to Install an EFV 4.9.1 – Revised – Existing natural gas customers shall receive annual notification of their right to request an EFV to be installed on their existing service line. Annual notification is through the direct mailing or electronic billing insert of the Natural Gas Safety Flyer, see PUBL 3 for the Flyer. Existing language states the customers will be notified. This additional language describes how existing customers are notified that they can request an EFV to be installed on their existing service line.</p> <p>4.9.2 – Grammatical correction – "customer's" replace "customers" 4.9.5 – Updated Paragraph reference links – 4.8.3 and 4.8.4. Adjustment to reference links is due to insertion of Summary Table in 4.4.</p>	<p>December 15, 2021</p>	<p>April 1, 2023</p>
<p><u>STLP 1</u></p>	<p>Requirements 12.0 Pipe Thread Sealers 12.2 – Removed This subsection contained specifications for thread sealers. Gas Standards and Material is responsible for approving products based on their review and evaluation. These specifications do not provide any value to the O&M.</p>	<p>October 1, 2022</p>	<p>April 1, 2023</p>
<p><u>STLP 3.1</u></p>	<p>Weld Fittings Appendix D Reducing Tees and Concentric Tees Title – Added - Tees Removed Stock Code 19 33 234 – 1-1/4" x 3/4" Reducing Tee AIC no longer uses and the MDF no longer stocks</p>	<p>April 1, 2021</p>	<p>April 1, 2023</p>

UNCONTROLLED IF PRINTED

<p><u>TURN 2.1</u></p>	<p>Residential/Small Commercial Customer 12.0 Lighting Appliances 12.4 Residential Boilers 12.4.1 – Corrected Reference Link – TURN 2.4 Section 7.0</p>	<p>October 1, 2022</p>	<p>April 1, 2023</p>
<p><u>TURN 2.3</u></p>	<p>Discontinuance or Transfer of Gas Service 7.0 Hard Disconnect (Terminate Service) 7.6 NOTE – Revised – If piping or meter is removed, cap or plug all open ends of piping, meter, and valves. An O&M Change Request was submitted to add meter to the NOTE. This makes it clear when the meter is removed the meter bar spuds are to be capped or plugged. The inlet spud is a potential route for gas to escape to the atmosphere</p>	<p>April 1, 2021</p>	<p>April 1, 2023</p>
<p><u>UPRT 0</u></p>	<p>Table of Contents UPRT 1 Section 5.0 – Increasing MAOP Up to 125 psig Section 6.0 – Increasing MAOP Above 125 psig</p>	<p>October 1, 2020</p>	<p>April 1, 2023</p>
<p><u>UPRT 1</u></p>	<p>Requirements 2.0 Scope 5.0 Increasing MAOP Up to 125 psig 6.0 Increasing MAOP Above 125 psig 5.0 – Updated - Increasing MAOP Up to 125 psig 5.2 – New – Polyethylene (PE) Systems 5.2.1 - PE systems can be uprated to a new MAOP that does not exceed the MAOP shown in <u>POLY 2.1 Section 6.0 MAOP Limitations for PE Pipe</u> if: 5.2.2 - The review steps as outlined in Paragraph 5.1.1 through 5.1.6 have been successfully completed. AND 5.2.3 - The existing PE system has records that demonstrate the system had been tested at 1.5 times the proposed MAOP, at a minimum. OR 5.2.4 - If there are no test records that substantiate the proposed Design MAOP, the PE pipe system can be uprated after being retested if: 1. The system is taken out of service and-tested to 1.5 times the proposed MAOP, at a minimum, in accordance with PTST 1. 2. The system operating pressure shall be established at, or below, the new MAOP before the PE system is placed back in-service. PHMSA's regulations for Uprating handle PE systems different than Steel systems. The Code requires PE systems be tested at 1.5 times the MAOP before being placed in-service. 5.3 Uprating 5.3.2 The pressure shall be increased gradually at a rate that can be controlled 1. – Updated the reference to 5.3.2 Item 1. 6.0 Increasing MAOP Above 125 PSIG.</p>	<p>October 1, 2020</p>	<p>April 1, 2023</p>

	<p>6.1 – Updated – "to or above 125 PSIG"</p> <p>Changing the MAOP from 100 psig to 125 psig is due to under certain circumstances PE systems can now have an MAOP of 125 psig as described in POLY 2.1 Design Pressure.</p>		
<u>WELD 2.3</u>	<p>Construction of Pipelines</p> <p>9.0 Welding Requirements</p> <p>9.16 Inter-pass Cleaning and Removal of Visual Defects</p> <p>9.16.3 – Removed "starts and stops". Clusters of surface porosity and high points shall be removed by grinding prior to installation of the next pass.</p> <p>Welding trainer indicated that starts and stops on the inter-passes can be cleaned by wire brushing and grinding is not necessary. Start and stops on the root bead do need grinding and that is covered in Paragraph 9.12.1.</p>	October 1, 2020	April 1, 2023
<u>WIGE 0</u>	<p>Table of Contents</p> <p>WIGE 3 Forms and Reference Materials - New</p>	April 1, 2021	April 1, 2023
<u>WIGE 2.1</u>	<p>Hazardous Environment</p> <p>4.0 General</p> <p>4.1 – "CGI" replaced "gas detection instrument"</p> <p>Added:</p> <p>4.1.1 - An approved hands-free air monitor can be used in-lieu of a CGI for monitoring the work area environment. See WIGE 3 for manufacturer's instructions.</p> <p>4.1.3 – Follow the manufacturer's instructions for operating, calibrating, and maintaining.</p> <p>SMR Team feels the use of personal air monitors would be an additional safety precaution when working in a gaseous environment. Allows for the use of both hands in the work area.</p> <p>7.0 Working in a Hazardous Outdoor Atmosphere Due to Gas-In-Air</p> <p>7.1.1 – Updated reference EXCV 2.9</p> <p>8.0 Shut Down Options When Working in a Hazardous Outdoor Environment Due to Gas-In-Air</p> <p>8.1.1, Item 3 – Above grade. Added reference link STLP 2.3 Steel Pipe Squeeze-Off.</p> <p>8.1.2, Item 3 – Below grade. Added reference link STLP 2.3 Steel Pipe Squeeze-Off.</p> <p>Document Rescission</p> <p>Updated – WIGE 2.1 Working in Gaseous Environment</p>	April 1, 2021	April 1, 2023
<u>WIGE 3</u>	<p>Forms and Reference Materials</p> <p>Reference Materials</p> <p>RKI GX-3R Manual</p> <p>AIC approved the RKI GX-3R personal air monitor for use when working in hazardous environment as an additional safety item.</p>	N/A	April 1, 2023

Document Rescission

SUMM - Change Summary, October 1, 2022.

UNCONTROLLED IF PRINTED

UNCONTROLLED IF PRINTED

CHANGE SUMMARY

October 1, 2022

Complete Change Summary			
Docu- ment	Change Summary	Previous Doc- ument Dated	Current Docu- ment Dated
<u>ABND 2.1</u>	<p>Abandonment of Gas Facilities</p> <p>11.0 Records</p> <p>11.2 – Update – service stub longer than 18 inches is to be mapped in AIC's electronic mapping system.</p> <p style="color: red;">Change required to be consistent with ClickMobile instructions and Paragraph 6.1.4.</p>	April 1, 2021	October 1, 2022
<u>ACIG 2</u>	<p>Work Area Protection</p> <p>5.0 Tools and Equipment</p> <p>5.3 – New – Locate VEU or Compression System (ZEVAC) air/gas seal vent at least 15 feet away from the air compressor or other ignitions sources.</p> <p style="color: red;">Equipment manufacturer's recommendation to eliminate possible ignition if gas so vent.</p>	October 1, 2021	October 1, 2022
<u>APPR 2.3</u>	<p>Gas Storage</p> <p>1. First Step</p> <p>D. 1300 – Update – Working in Gaseous Environment.</p> <p>3. Third Step</p> <p>Q. Third Step Qualifications: ASME B31Q Operator Qualifications Performed at the End of the Third Step:</p> <p>Added:</p> <p>1381 – Operate Gas Pipeline – Local Facility Remote=Control Operations.</p> <p>1631 - Launching and or receiving internal Device (pigs) lines out of service.</p> <p>1641 - Launching and or receiving internal Device (pigs) lines in of service.</p> <p>1671 - Inspect & Maintain a Pipeline Heater.</p> <p>1681 - Inspect & Maintain Liquid Knockout System.</p> <p>1891 - Inspect & Maintain Glycol Dehydration System.</p> <p>1701 - Inspect & Maintain Mole Sieve Dehydration System.</p>	February 1, 2010	October 1, 2022

UNCONTROLLED IF PRINTED

	Updated by Gas Training Department		
<p><u>APPR</u> <u>2.4</u></p>	<p>Gas Technical Services</p> <p>1. First Step</p> <p>B, 1100 (2) – Update – Pipeline Heaters replaces Pipeline Boilers</p> <p>2. Third Step</p> <p>F. Third Step Qualifications -ASME B31Q Operator Qualifications Performed at the End of the Third Step.</p> <p>Added:</p> <p>0371 - Hydraulic Actuator/Operator Inspection and Testing, Preventive and Corrective Maintenance.</p> <p>1381 - Operate Gas Pipeline – Local Facility Remote=Control Operations.</p> <p>1631 - Launching and/or Receiving Internal Devices (Pigs) with a temporary launcher and/or receiver for Lines Out of Service.</p> <p>1641 - Launching and/or Receiving Internal Devices (Pigs) for Lines in Service.</p> <p>1671 = Inspect and Maintain a Pipeline Heater.</p> <p style="color: red;">Updated by Gas Training Department</p>	<p>April 1, 2012</p>	<p>October 1, 2022</p>
<p><u>CORR 1</u></p>	<p>Requirements</p> <p>18.0 Records</p> <p>18.1 – Grammatical – Added (CP) as acronym for cathodic protection.</p> <p>18.3 – Cathodic protection structure maps –</p> <p>18.3.1 The maps shall include the location of:</p> <p>Added:</p> <p>Cathodically protected mains.</p> <p>Anode bank.</p> <p>Rectifiers and associated ground bed.</p> <p>CP test points.</p> <p>5# and 17# anodes attached to CP structures.</p> <p>NOTE – Location of 5# anode connected to tracer wire for a PE main installation should be mapped.</p> <p style="color: red;">Gas Compliance request better clarification as to what is to be mapped in the electronic mapping system.</p>	<p>October 1, 2021</p>	<p>October 1, 2022</p>
<p><u>CORR</u> <u>2.1</u></p>	<p>Cathodic Protection Design</p> <p>8.0 Insulating Materials</p> <p>8.4 Insulating Unions</p>	<p>May 15, 2022</p>	<p>October 1, 2022</p>

	<p>Table 3 Insulating Unions – Updated column heading to Class 150 and Class 3000. Corrected Stock Code for 1-1/4" Class 150 union New Table 4 – Pressure – Temperature Ratings. <i>After consultation with the manufacturers, it was confirmed the previously listed 150 psig Insulating Union are Class 150 with a pressure rating of 300 psig at temperatures between -20°F to 150°F.</i> <i>Table 4 was added to show the pressure ratings at higher temperatures.</i></p>		
<p><u>CORR</u> <u>2.3</u></p>	<p>Coatings 2.0 Scope Added Section 12.0 Approved Epoxy Coating for Submerged Facilities Appendices: Added- Appendix M - Approved Epoxy Coatings for Submerged Facilities 4.0 Approved Coatings 4.1 – Grammatical – added "lists" 4.1.2 – Grammatical – "inches" replaced "inch" 11.0 Coating Inspection 11.1 – Grammatical – Removed "All" 11.2 Inspection Requirements 11.2.1 All pipe coating shall be visually inspected ... 2 b. – New – Inspect coating on pipe that does not require use of holiday detector, per Appendix K-1, by sliding hands along the pipe feeling for rough spots then visually inspect those locations. 12.0 Approved Applied Epoxy Coating for Submerged Facilities – New section. Information for the application of Denso SeaShield 525 and SeaShield 526 Epoxy coating on facilities that are either subjected to routinely or permanently submerged. <i>This addition is a result of a request from GTE to approve these two products for coating facilities that are subjected to routine or permanent submergence. Corrosion control approved these products for that specific purpose.</i> Appendix G – Moisture Cured Wrap Updated Stock Code for Polyethylene/Stretch Wrap – 49 22 492. Appendix I – Specific Coatings I-5 Moisture Cured Wrap 5. MCW Coverage Table.</p>	<p>October 1, 2021</p>	<p>October 1, 2022</p>

	<p>Updated table with all of the roll sizes currently stocked.</p> <p>Appendix L – Protal Applications</p> <p>5. Protal Coverage Tables</p> <p>Added coverage tables for:</p> <p>5. B. Weld Joints</p> <p>5. C. Bore Joints</p> <p>5. D. Product Coverage</p> <p>Protal Coverage Tables had been previously removed from the O&M but GTS requested they added back. Coverage tables come from Denso Protal Liquid Coatings Quantity Estimate Sheet.</p> <p>Appendix M – Epoxy Coating for Submerged Facilities.</p> <p>Stock Codes for Denso SeaShield 525 and SeaShield 526.</p>		
<p><u>CORR</u> <u>2.10</u></p>	<p>Rectifier Maintenance and Troubleshooting</p> <p>Appendix A – Rectifier Installation</p> <p>3.3 Material List – Dryconn VisiLock with Smart Gel replaced #90-B-1 Epoxy Splice Kit</p> <p>4.1.1 – Grammatical – Reworded – The Dryconn splice box does not have a shelf life or temperature restraints whereas the 3M A Scotchcast Resin Kit does.</p> <p>Corrosion control has made this substitution due to better sealing of the connection.</p>	<p>October 1, 2020</p>	<p>October 1, 2022</p>
<p><u>DAMG 1</u></p>	<p>Requirements</p> <p>2.0 Scope</p> <p>Removed Section 8.0 Protection of Excavated Facilities</p> <p>4.0 Types of Locate Requests</p> <p>4.1.3 – Added – A locate request is submitted to JULIE through one of the following means:</p> <p>1. Remote Ticket Entry – For professional excavators. AIC utilizes RTE.</p> <p>2. On-line with E-Request – for non-emergency locate requests- for homeowners and excavators.</p> <p>This was added to match information on Illinois1call website.</p> <p>5.2.4 Difficult to Locate Facilities</p> <p>2 e. – Coordinate with excavator for such action as:</p> <p>Moved - gas field personnel stand-by while excavation crossed the facility, as a Last Resort.</p> <p>QA and OQ sections felt stand-by should be the last resort since AIC has the ability to locate these facilities.</p>	<p>October 1, 2021</p>	<p>October 1, 2022</p>

	<p>Removed 8.0 Protection of Excavated Facilities Safety Wrap that is addressed in this section is no longer being manufactured and there is no replacement for that product.</p> <p>Reference Documents Removed - The Illinois Underground Utility Facilities Damage Prevention Act. This Act is included in the JULIE Excavator Handbook which is also a Reference Document.</p>		
DAMG 2	<p>Reporting JULIE Violations</p> <p>4.0 Reportable Violations</p> <p>4.1.5 – Item 2 – 18 inches replaced 1 ½ feet on either side of marked facilities. Tolerance Zone QA and OQ requested since the JULIE website refers to 18 inches rather than 1 ½ feet.</p> <p>Reference Documents Removed - The Illinois Underground Utility Facilities Damage Prevention Act. This Act is included in the JULIE Excavator Handbook which is also a Reference Document.</p>	October 1, 2020	October 1, 2022
EMER 0	<p>Table of Contents</p> <p>New EMER 2.11 Gas Storage</p>	April 1, 2021	October 1, 2022
EMER 1	<p>Requirements</p> <p>5.0 Procedures</p> <p>Added 5.1.12 Gas Storage Emergency Plan Compliance Requirements:</p> <p>Added 49 CFR §192,12 Underground Natural Gas Storage Facilities.</p> <p>Reference Documents</p> <p>Added EMER 2.11 Emergency Plan: Gas Storage</p>	April 1, 2021	July 22, 2022
EMER 2.2	<p>Dispatch Center</p> <p>3.0 Target Audience</p> <p>Updated a couple of job titles:</p> <p>Gas Distribution System Operating Supervisor (GDSOS)</p> <p>Gas Dispatch Superintendent</p> <p>5.0 Dispatching Gas Field Personnel to Emergency Call</p> <p>Throughout Section 5.0 – GDSOS replaced Dispatcher</p> <p>NOTE: Customer Care Center replaced Customer Service Representative.</p> <p>Gas Dispatch replaced Dispatch Center.</p> <p>GDSOS replaced Dispatcher.</p>	May 15, 2022	October 1, 2022

	<p>5.6 NOTE – Added Electric – Electric Distribution Control has compiled and maintains the 911 numbers</p> <p>6.0 Action Required of Supervisory Personnel Throughout Section 6.0 – GDSOS replaced Dispatcher</p> <p>7.0 Cold Weather Electrical Outage and Restoring Service</p> <p>7.1.1 – Grammatical – "instantaneous gas load can exceed the capacity of the affected gas systems" replaced "hundreds of gas furnaces simultaneously call for heat"</p> <p>7.1.2 – Grammatical – "operating pressures well below their designated setpoints" replaced "low pressure".</p> <p>7.1.3 – Revised – Conditions identified that will enact the Electric Cold Load Restoration Policy, refer to EMER 3 for the policy:</p> <ol style="list-style-type: none"> 1. Ambient temperature 20 °F or less at the location of outage. AND 2. Duration of the electric outage in excess of 4 hours. 3. High Risk Gas Systems have been identified for pressure monitoring and/or electric circuit segmentation during restoration efforts. These high-risk Gas Systems are located in the ElectricColdLoadPickup.xlsx file. <p>Removed the Table showing the High and Moderate Risk Gas System Risk Level designations.</p> <p>Manager Gas Tech Services and Gas Control updated the Electric Cold Load Restoration Policy. The 20°F replaced 32°F and the 4-hour duration replaced 2-hour duration. The Gas Risk level is now identified in the Electric Cold Load Pickup spreadsheet.</p> <p>The update Electric Cold Load Restoration Policy is already being used by Electric Distribution Control.</p> <p>7.2 – Grammatical – Distribution System Operations Supervisor (DSOS) replaced Electric Distribution System Operations Supervisor (EDSOS). "electric outage exists over an identified Gas System and will exceed both of the thresholds" replaced "electric outage and will exceed the thresholds".</p> <p>GTS replaces Gas Tech Services.</p> <p>7.3 Contact Lists for Gas Tech Services (GTS) replaced Gas Tech Support.</p>		
<p>EMER 2.4</p>	<p>Gas Field Personnel – General</p>	<p>October 1, 2021</p>	<p>October 1, 2022</p>

	<p>4.2.1 – Grammatical – Check the meter, riser, and customer fuel line with volt stick.</p> <p>1. Updated link – Volt stick alarms; See METR 2.2 Subsection 7.3 AC Voltage Action Table.</p> <p>2. Moved from 4.2.2 - Volt stick alarms on riser, do not shut-off meter valve.</p>		
<u>EMER 2.4.3</u>	<p>Gas Field Personnel – Dispatched to Major Leak or Line Break</p> <p>1.5.1 If the leak or line break is freely blowing:</p> <p>1. Revised – Maintain a safe zone from the blowing gas in accordance with WIGE 2.1 Section 6.0 Safety Zone.</p> <p>Revised to be consistent with WIGE 2.1 Section 6.0. Removed the minimum 20 feet because it appeared to conflict with WIGE 2.1.</p>	October 1, 2021	October 1, 2022
<u>EMER 2.4.5</u>	<p>Dispatched to Gas Related Fire, Ignition, or Explosion</p> <p>1.10 If Fire Department is already on site:</p> <p>1.10.1 – Revised – Has Fire Department shut off gas to the burning structure?</p> <p>1. Revised – If shut off done, ask for permission to inspect the meter set.</p> <p>Firemen are not authorized to shut off our meter valves so reference to our meter valve is being removed.</p> <p>1.10.2 – Revised – Fire Department has shut off the gas and granted permission to inspect the meter set.</p> <p>2. Confirm if the meter valve or a customer convenience valve (CCV) had been shut off.</p> <p>2 a. – If CCV has been shut off, the meter valve can be left open.</p> <p>2.b. – If meter valve has been shut off, red pin the meter valve.</p> <p>Remove 2 c. If the valve is NOT shut off, shut off the valve and red pin the meter valve.</p> <p>If the Fire Department has shut off the CCV, the meter valve can be left open unless the Fire Department wants our meter valve shut off.</p>	October 1, 2020	October 1, 2022
<u>EMER 2.4.6</u>	<p>Dispatched to Non-Gas Related Fire, Ignition, or Explosion</p> <p>1.4 Make Contact with Fire Chief or fireman in charge.</p> <p>1.4.1 Revised – Has Fire Department shut off the gas to the structure or do they want the gas shut off?</p> <p>1.4.2 Revised – If Fire Department has shut off the gas, ask permission to inspect the meter set.</p>	October 1, 2020	October 1, 2022

	<p>2. Revised – If permission is granted, need to verify gas has been correctly shut off.</p> <p>3 b. Added – Determine what follow-up action is needed</p> <p>This was added if the gas meter cannot be safely approached.</p> <p>4. New – Confirm if the meter valve or a customer convenience valve (CCV) has been shut off.</p> <p>4 a. New – If CCV has been shut off, the meter valve can be left open.</p> <p>4 b. Revised – If the meter valve has been shut off, red pin the valve.</p> <p>1.4.3 Revised – If the supply needs shut off and the gas meter set can be safely approached:</p> <p>2. Revised – Shut off the CCV, if one is available, and leave meter valve on, OR</p> <p>3, New - Shut off and red pin the meter valve.</p> <p>1.4.4 – New – If the gas supply does not need to be shut off, the meter valve and CCV, if present, can be left on. See Subsection 1.6.</p> <p>1, New – Enter comment on OAS 63 screen that gas service did not need to be shut off.</p> <p>1.7 New – Service cannot be restored to the customer until:</p> <p>1.7.1 New – Fire Department has completed their investigation or has released the scene. AND</p> <p>1.7.2 New – Gas field personnel have inspected the facilities for damage. AND</p> <p>1.7.3 – No damage was found. OR</p> <p>1.7.3 New – Damaged facilities isolated, replaced, or repaired.</p>		
<p><u>EMER</u> <u>2.5</u></p>	<p>Natural Disasters or Civil Disobedience</p> <p>5.0 Natural Disasters: Floods</p> <p>5.1 Prior to Flooding:</p> <p>5.1.3 Leave the system pressurized</p> <p>1. New – Service can be left on as long as the regulator and relief vent are extended above the expected high-water line.</p> <p>2. New – Gas meter will function when submerged, but the AMI device will require replacement following submergence</p> <p>5.1.4 – Revised – Shutting off and locking individual services where regulator and relief vents could be submerged, with priority given to inside services.</p>	<p>October 1, 2021</p>	<p>October 1, 2022</p>

5.2 During the Flood – Changed from Flooded Area

5.2.6 – Revised – Determine whether facilities (such as meter sets, regulator stations, valve stations, farm taps, and relief vent lines) that have become submerged could be struck by watercraft or floating debris.

5.3 Following the flood, the Gas Supervisor or GTS Supervisor, where applicable, shall ensure the following actions are taken. – Changed from Following the Flood

5.3.3 New – Replace AMI devices on all gas meters that were submerged during the flood.

1. AMI can be replaced on the existing meter, OR
2. Exchange the meter and ship to the Gas Meter Shop. The meter shall be tagged "Submerged".

5.3.4 Move from 5.1.5 – Issue a Warning Tag if:

1. Water had covered the control valves on interior appliances, OR
2. If service has been shut off. Refer to TURN 2.7 Warning Tag.

Grammatical change in sections 5.3.3 through 5.3.11:

Created action verbs by removing "ing".

Provides more information addressing gas facilities that have or could be submerged due to flooding especially the AMI devices which must be replace if submerged

<p><u>EMER 2.11</u></p>	<p>Gas Storage This procedure outlines the requirements and corresponding steps to address emergency situations. This procedure identifies roles and responsibilities of individuals during an event.</p>		<p>July 22, 2022</p>
<p><u>EMER 3</u></p>	<p>Forms and Reference Materials Reference Materials Updated Electric Cold Load Restoration Policy (March 31, 2022)</p>	<p>April 1, 2021</p>	<p>October 1, 2022</p>
<p><u>GLOS</u></p>	<p>Glossary Acronyms: Added ASV – Automatic Shut-off Valve RCV – Remote Controlled Valve RMV – Rupture Mitigation Valve Definitions: Branch Service – Updated - A gas service line that begins at the existing service line or is installed concurrently with the primary service line but serves a separate: <ul style="list-style-type: none"> • Adjoining or adjacent residential or small commercial customer. Or • Multiple residential or small commercial customers served through a meter header or manifold Entirely Replaced Onshore Transmission Pipeline Segments - For the purpose of § Part 192.179 NS 192.634, where 2 or more miles, in the aggregate, of onshore transmission pipeline have been replaced within any 5 contiguous miles of pipeline within any 24-month period. Notification of Potential Rupture - The notification to, or observation by, an operator of indications identified in § 192.635 of a potential unintentional release of a large volume of gas from a pipeline. Remote-Control Valve – Updated from Remote Operated Valve Rupture Mitigation Valve (RMV) - An automatic shut-off valve (ASV) or a remote-control valve (RCV) that a pipeline operator uses to minimize the volume of gas release from a pipeline and to mitigate the consequence of a rupture.</p>	<p>October 1, 2021</p>	<p>October 1, 2022</p>
<p><u>INCD 1</u></p>	<p>Requirements 5,0 Natural Gas Incident 5.1.3 – Updated PHMSA's estimated property damage level to \$129,300.</p>	<p>May 15, 2022</p>	<p>October 1, 2022</p>

	<p>Appendix B – State and Federal Reporting Matrix</p> <p>Item 3 - Updated PHMSA's estimated property damage level to \$129,300.</p> <p>PHMSA annually publishes an update to the estimated property damage. The updated value is effective as of July 1, 2022.</p>		
<u>INVE 2.1</u>	<p>Incident Investigations</p> <p>6.0 Incident Commander Responsibilities – Facility Investigation</p> <p>6.3 Ensure AIC gas field personnel:</p> <p>6.3.4 – Revised – Request remote automated meter readings, AMI, as soon as practical by contacting the Integrated Operation Center (IOC) Hotline at 835-904-2462, 24 hours per day / 7 days per week.</p> <p>Contact information has been added so that gas field personnel knows how to request AMI readings.</p>	October 1, 2021	October 1, 2022
<u>INVE 3</u>	<p>Forms and Reference Materials</p> <p>Updated:</p> <p>Gas Incident Investigation Log</p> <p>Failed Gas Material Tag</p> <p>AMI replaced AMR in the Incident Investigation Log.</p> <p>Failed Gas Material Tag - Shipped to address is now found in INVE 2.3 Section 5.3. Eliminates the need for a new Tag when ship to address changes.</p>	October 1, 2020	October 1, 2022
<u>LEAK 0</u>	<p>Table of Contents</p> <p>LEAK 5 – Added Section 12.0 Cavity Ring-Down Spectroscopy. This moved Records to Section 13.0.</p> <p>LEAK 2.8 – New Section – Advanced Mobile Leak Survey.</p> <p>LEAK 2.9 – Survey Maps and Records – moved from LEAK 2.8.</p>	October 1, 2020	October 1, 2022

<p><u>LEAK 2.1</u></p>	<p>Indoor Investigations</p> <p>5.0 Upon Arrival</p> <p>5.3 – Added – "Verify meter number if applicable."</p> <p>This is a way of confirming that one is at the correct location especially if a customer is the one that is reporting a possible leak.</p> <p>7.0 Customer Home</p> <p>7.5 – Grammatical – "is" replaced "are"</p>	<p>May 15, 2022</p>	<p>October 1, 2022</p>
<p><u>LEAK 2.2</u></p>	<p>Outdoor Investigations</p> <p>5.0 Upon Arrival</p> <p>5.3 – Added – "Verify meter number if applicable."</p> <p>6.0 Below-Grade Gas Facilities</p> <p>6.1 Investigation should include the following locations:</p> <p>6.1.1 through 6.1.11 – rearranged to match the Leak Investigation Form in LEAK 2.3 and the list on the 6F screen.</p> <p>Former 6.4 and 6.4.1 through 6.4.3 have been removed since they repeated items listed under 6.1.</p> <p>6.4 is former 6.4.4 – If you suspect migration to a structure, obtain additional samples inside. For possible hazardous conditions, see Section 9.0</p> <p>7.0 Above-Grade Gas Facilities</p> <p>7.2 – Removed – Begin leak investigation where leak was reported.</p> <p>SMR Team felt that this was covered in Sub-section 5.6.</p> <p>10.0 Leak on Customer-Owned Facilities</p> <p>10.1 If a gas leak is discovered on a customer-owned buried fuel line</p> <p>10.1.2 If simple repairs cannot be made</p> <p>1. If leak is on customer fuel line that extends into the structure:</p> <p>1 a. Isolate the gas leak upstream of the leak by:</p> <p>I. Shutting off Customer owned valve, or</p> <p>Allows using the customer's valve to isolate the leak. This is consistent with the procedures in LEAK 2.1 Inside Investigation.</p>	<p>May N15, 2022</p>	<p>October 1, 2022</p>

<p><u>LEAK 2.3</u></p>	<p>Leak Investigation Form 1.0 Purpose – Added ClickMobile Leak Investigation Form. 2.0 Scope – Appendices - Added Appendix B: ClickMobile Leak Investigation Form New Appendix B - ClickMobile Leak Investigation Form</p>	<p>October 1, 2021</p>	<p>October 1, 2022</p>
<p><u>LEAK 2.4</u></p>	<p>Leak Surveys 6.0 Business Districts 6.5 – Revised - Inside service regulators shall have their regulator vent and relief vent piped and terminated outdoors. The relief vent shall terminate such that gas can escape freely to the atmosphere and away from ignition sources or openings into the structure. The Federal Pipeline Safety Act requires that inside regulators have their vents and relief valve vents piped outdoors so gas can vent freely and away from ignition sources.</p>	<p>December 15, 2021</p>	<p>October 1, 2022</p>
<p><u>LEAK 2.5</u></p>	<p>Leak Survey Equipment 2.0 Scope Section 12.0 Cavity Ring-down Spectroscopy – New 12.0 - Cavity Ring-down Spectroscopy (CRDS) – New This section describes the equipment utilized in the Advanced Mobile Leak Survey vehicle. 13.0 Records – Moved from 12.0</p>	<p>April 1, 2021</p>	<p>March 1, 2022</p>
<p><u>LEAK 2.8</u></p>	<p>Advanced Mobile Leak Survey – New Procedures for performing mobile leak survey that utilizes the Cavity Ring-down Spectroscopy</p>	<p>N/A</p>	<p>March 1, 2022</p>
<p><u>LEAK 2.9</u></p>	<p>Records Moved from LEAK 2.8 – No changes made</p>	<p>December 15, 2021</p>	<p>October 1, 2022</p>
<p><u>METR 0</u></p>	<p>Table of Contents METR 2.5 Gas Meter Bypass Section 7.0 Using Portable CNG Tank with the Mueller Brisco Valve Section 8.0 Refilling Portable CNG Tanks – New Section 7.0 was actually added to with the April 1, 2021 O&M Update but was not added to METR 0.</p>	<p>October 1, 2020</p>	<p>October 1, 2022</p>

<p><u>METR 1</u></p>	<p>Requirements</p> <p>6.0 Gas Meter Location</p> <p>6.3 Unacceptable Meter Locations</p> <p>6.3.10 Where the service regulator vent is:</p> <p>4. Stock Codes added for the 2 approved slam-shut regulators: BelGas P100SX – 6206495 and the PF-25 – 6206496.</p> <p>Remove reference to METR 4.</p> <p>4 a. - Regional Director approval is required for the installation either of these slam-shut regulator.</p> <p>The use of slam-shut regulators should be limited to only those situations where it is not feasible to vent or relocate the regulator. Regional Director's approval will have to approve the use of the slam-shut regulator.</p> <p>4 b. – New – Regulator capacity information is in METR 3.2 Appendix A.</p> <p>4 c. – Manufacturer's Operating Manuals are in METR 4</p> <p>7.0 Installation</p> <p>7.8 Gas meter set susceptible to flooding</p> <p>7.8.1 Revised - Regulator vent lines extended above expected high-water line, OR</p> <p>7.8.2 Revised - Regulator and meter installed above the expected <u>high-water line</u>, OR</p> <p>7.8.3 Revised - Designated as; need to be removed during flood conditions.</p> <p>NOTE: Gas meters will function when submerged but will need the AMI device replaced following submergence.</p> <p>Information added to be consistent with the requirements for meter sets in flood prone areas addressed in EMER 2.5 Section 5.0 Natural Disasters: Floods.</p>		
<p><u>METR 2.4</u></p>	<p>Meter Inspection and Testing – GTS / GCD</p> <p>1.0 Purpose</p> <p>Added – Gas Control and Dispatch (GCD)</p> <p>GTS and GCD each have technicians that are involved with meter inspection and testing,</p> <p>3.0 Target Audience</p> <p>Added:</p> <p>Gas Tech Services (GTS) Technicians</p> <p>Supervisor, Gas SCADA</p>	<p>October 1, 2021</p>	<p>October 1, 2022</p>

	<p>Gas Control Technicians (GCT) Removed: Gas Supervisors Gas Field Personnel 6.0 Turbine Meters 6.5 Minimum Spin Times 6.5.1 – Added Table 3 Table 3: Sensus Auto-Adjust Turbine Meters – Spin Times. Table shows the minimum spin time at various ambient air temperature ranges from Above 59°F down to 19°F .for Main Rotor and Sense Rotor. Minimum spin times were needed for the Sensus Auto-Adjust turbines that AIC has in their gas system. 7.0 Ultrasonic Meter Testing 7.3 Transmitter Inspection 7.3.4 – Grammatical – Confirm that the transmitter output scaling matches the on-site flow computer output.</p>		
<p><u>METR 2.5</u></p>	<p>Gas Meter Bypass 2.0 Scope Added Section 8.0 – Refilling Portable CNG Bottles 8.0 Refilling Portable CNG Bottles Operating instructions for refilling portable CNG bottles from the CNG Trailer. Modifications to the CNG trailers have been made to enable the safely refilling of portable CNG bottles used by AIC gas personnel for bypass operations.</p>	<p>April 1, 2021</p>	<p>October 1, 2022</p>
<p><u>METR 2.7</u></p>	<p>Gas Metering Corrections 2.0 Scope Inserted a new Section 5.0 Electronic Corrector New Installation, Field Exchange or Transfer Process Section 9.0 – AMI Reading Verification – Removed AMR. 4.0 General 4.4 – Removed, the information is being added in other sections. 5.0 Electronic Corrector New Installation, Field Exchange or Transfer Process – New Outlines the required tasks the Gas Meter Shop personnel, Region's gas field personnel and GTS Technicians are responsible for performing</p>	<p>October 1, 2020</p>	<p>October 1, 2022</p>

when an electronic corrector is installed or transferred.

Gas Metering and GTS personnel prepared these instructions to ensure that the electronic correctors are installed and programmed correctly,

6.0 Electronic Corrector Inspection – Verification Schedule

6.2 – New - During the verification process, the activities and particulars outlined in Appendix A Electronic Corrector Documentation shall be documented on Appendix C Electronic Corrector Verification Form

6.3 New - Customer Service System (CSS) will automatically initiate the generation of an OAS order (MJ44) immediately after the corrector is installed on an account in CSS, or after being transferred to a gas meter at the premise based upon "set date".

These procedures ensure that electronic corrector verifications are being properly scheduled, performed and documented. Illinois Administrative Code 501 requires the verification to be performed within 60 days after the corrector was installed.

Instructions

9.0 AMI Reading Verification – Removed AMR

9.1 – Removed references to AMR.

AMI's has replaced AMR's

Appendix A Electronic Corrector Documentation

A-1 – Added - "exchange" along with installation and transfer that require documentation

A-3.1.8 – Added - Ch. A Output (#93 CorVol Pulses)

A-3.1.12 – Expanded - Fixed Temp Factor (#111 – specific to TC on meter "Live" if meter is non-TC with no temperature probe. If Temp is fixed, Item #1055 must be "No" and #1162 must be "60" on an EC350.)

A-3.1.15 – New - Ch. A Pulse On/Off (#1014 should be Closed – 50 ms and Open – 250+ ms)

A-3.1.16 – New - Ch. A Pulse output (#1193 – 1000 CF)

A-7 – Removed AMR

A-7.1 - Removed AMR

A-7-2 - Removed AMR

Appendix B – Electronic Corrector Maintenance

B-7 - Removed AMR

B-7.1 – Removed AMR

UNCONTROLLED IF PRINTED

	<p>B-7.2 – Removed AMR</p> <p>Appendix C – Electronic Corrector Verification Form</p> <p>AMI replaced AMR</p> <p>Under Device Programming – Added</p> <p>93 Ch. A Output</p> <p>1014 Ch. A Pulse On/Off</p> <p>1193 Ch. A Pulse output</p> <p>Appendix D – Electronic Corrector Inspection Form</p> <p>AMI replaced AMR</p> <p>Under Temperature Verification</p> <p>Removed - Temperature Simulator Tolerance Acceptable</p>		
<p><u>METR</u> <u>2.10</u></p>	<p>Gas Meter Data Sheet</p> <p>4.0 Gas Meter Data Sheet</p> <p>4.1.1 - This information is also maintained and utilized for weekly metering verification and pressure factor verification process that is performed annually. See METR 2.8 Pressure Factor Metering</p> <p>4.2.1 – Change to meter pressure greater than 12"w.c.</p> <p>4.2.2 – Elevated metering pressure is increased or decreased, such as:</p> <p>2. Decrease from 5 psig to 2 psig, etc.</p> <p>4.2.5 – Clarified – Data corrections for adjusting metering pressure errors and corresponding billing constants in CSS.</p> <p>4.2.6 – Eliminated – "Removed"</p> <p>4.2.6 – 4.- Modified i.e., changes in metering and delivery pressure.</p> <p>Added - NOTE: A GMDS is not required when exchanging a regulator and/or relief valve with a "like kind" which does not affect billing accuracy.</p> <p>Example: Replacing failed 289H relief valve with another relief valve that has the same set pressures as the failed 289H.</p> <p>4.3 – Revised - Modifying programming parameters on an electronic corrector that could affect billing adjustments.</p> <p>4.3.1 Adjusting the pulse output to an AMI module, OR</p> <p>4.3.2 Change to meter drive rate, etc.</p>	<p>October 1, 2021</p>	<p>October 1, 2022</p>

	<p>4.4 – New - This procedure is not applicable to ultra-sonic meters (USM) installed at a customer's premise</p> <p>5.0 Completion Instructions</p> <p>5.2 – Grammar correction – "and" replaced "too"</p> <p>5.2 Applicable pictures will be taken and attached to GMDS:</p> <p>5.2.3 – Added – if applicable</p> <p>5.2.5 – New – Corrector item file, if applicable.</p> <p>5.2.6 – Added – such as corrected and uncorrected meter readings.</p> <p>6.0 Report Distribution</p> <p>6.2 – Added – when Team App is not available and:</p> <p>6.3 – Removed – and @IL Cust Service Key Account</p> <p>Appendix A GMDS Completion Instructions</p> <p>A-3.5 – Added – Also, attach all required pictures to the electronic GMDS for the work performed.</p> <p>Above changes were made to clarify the instructions and provide additional instructions for completing the GMDS. These changes were approved by Metering and GTS leadership.</p>		
<p><u>METR</u> <u>3.2</u></p>	<p>Regulator Sizing</p> <p>Appendix A - Regulators with 7" w.c. Delivery Pressure</p> <p>Capacities added for the 2 Slam-Shut regulators</p> <p>BelGas P100SX and PF 25.</p> <p>Notes Added:</p> <p>(9) - Overpressure protection (slam-shut) reset shall follow manufacturers recommendations.</p> <p>(10) - Pietro Fiorentini FE25 use Main Spring (Yellow), 6" to 8" w.c. range, set 7" w.c., relief set at 14" w.c., slam-shut at 28" w.c.</p> <p>(11) - BelGas P100SX use Main Spring (007), 6" to 8" w.c. range, set 7" w.c.m relief set at 14" w.c., slam-shut at 28" w.c.</p> <p>Appendix C – Regulators with 5 psig Delivery Pressure</p> <p>Reference to Note (5) added to 2" Fisher 299H with 1/2" orifice, Inlet pressures of 80 psig through 125 psig.</p>	<p>December 15, 2021</p>	<p>October 1, 2022</p>

UNCONTROLLED IF PRINTED

	<p>Note (5) - Use 2" Fisher 289H Relief Valve with 1B536927052 Spring, 4 to 10 psig, set 7 psig, maximum buildup 10 psig, and capacity 44 MCF. (Stock No. 39 10 398)</p> <p>Appendix D - Regulators with 10 psig Delivery Pressure</p> <p>Reference to Note (6) added to 2" Fisher 299H with 1/2" orifice, Inlet pressures of 80 psig through 125 psig</p> <p>Note (6) – Use 1" Fisher 289P Relief Valve with 1B986027212 Spring, 10 to 18 psig, set 13 psig, maximum buildup 16 psig, and capacity 29.3 MCF. (Stock No. 39 22 035)</p>		
<u>METR 3.3</u>	<p>Diaphragm Meter Sets</p> <p>Appendix A through D – 175/250 Meter</p> <p>Added new Meter Bar with a Bypass CCV as an option.</p> <p>Eliminates the need to install the bypass Angle Valve or Brisco Valve</p> <p>Appendix J – 630 Meter, Bypass, 2, 5, & 10 psig Delivery</p> <p>Corrected color of CL-31N Spring to Blue</p>	October 1, 2021	October 1, 2022
<u>METR 4</u>	<p>Forms and Reference Materials</p> <p>Forms Updated:</p> <p>Electronic Corrector Inspection Form – Fillable (April 27, 2022)</p> <p>Electronic Corrector Verification Form – Fillable (April 27, 2022)</p> <p>Forms New</p> <p>Ultrasonic Meter Inspection Form - Daniel Meter</p> <p>Ultrasonic Meter Inspection Form - Instromet Meter</p> <p>Ultrasonic Meter Inspection Form - Sick Meter</p> <p>Appendix A – Ultrasonic Meter section</p> <p>Test Requirement Column</p> <p>Merge cells so that Multi-path ultrasonic applies to both Very conditions every 3 months and Flow calibrate every 120 months.</p> <p>Schedule Requirement Column</p> <p>Transmitter Inspection – Every 6 months (changed from 4 months)</p>	December 15, 2021	October 1, 2022
<u>OQAL 2.1</u>	<p>Covered Task</p> <p>Added:</p> <p>1671 – Inspect and Maintain a Pipeline Heater</p>	April 1, 2021	October 1, 2022

UNCONTROLLED IF PRINTED

<p><u>QCAL</u> <u>2.2</u></p>	<p>Covered Task with AOC's Added 1671 – Inspect and Maintain a Pipeline Heater</p>	<p>October 1, 2021</p>	<p>October 1, 2022</p>
<p><u>PMRK 2</u></p>	<p>Pipeline Facility Markers Appendix B-4 Navigable Water Crossing Sign 1. Sign is to be installed so that it is readable from the waterway and will be installed on both sides of the channel if required by the governing agency. Clarifies the agency with jurisdiction over the waterway may require the sign to be installed on both sides of the channel.</p>	<p>May 15, 2022</p>	<p>October 1, 2022</p>
<p><u>POLY</u> <u>2.2</u></p>	<p>Squeeze Off 4.0 General 4.1 – Revised – Gas flow in PE pipe can be controlled by squeezing the pipe with a squeeze-off tool marked ASTM F1563 or is certified as complying with ASTM F1563. NOTE: ASTM F1563 is Standard Specification for Tools to Squeeze-off PE Gas Pipe. 4.3 – New - All squeeze-off tools are required to be grounded when squeezing PE pipe. 4.4 – New – Squeeze-off tool manufacturer's information is in POLY 4 Reference Materials. 5.0 Operations 5.1 Before Starting Squeeze Off 5.1.1 – Added "the proper" – Do Not use squeeze tools without the proper pipe gap stops. 5.1.3 – Revised – Prevent the build-up of static electricity charge in PE pipe by: 1. Grounding the squeeze tool, AND 2. Spraying the 1-1/4 inches and larger pipe with Ionix Static Suppressor or wrapping the pipe with wet or soapy non-synthetic rags near point of cutting or repairs. All squeeze-off tools must be grounded per the ASTM Standards regardless of the pipe size being squeezed. The 1-1/4 inches and larger pipe will require additional static suppression due to the size of pipe and volume of gas affected by the squeeze. 5.2 Squeeze Off Tool Location and Operation 5.2.2 Locate squeeze tool minimum of 3 pipe diameters from: See Table 1 Table 1 - Revised the minimum distance.</p>	<p>May 1, 2022</p>	<p>October 1, 2021</p>

For pipe size less than 2 inches, the minimum distance was changed to 5 inches to make it easier for the field people to remember. Minimum distance for pipe 2 inches and larger was rounded to the next whole number.

5.2.4 – Revise – Operate the screw operated or hydraulic operated tool in a slow continuous manner, with a compression rate of approximately 2 inches per minute based on the pipe's outside diameter, to allow stress relaxation of the pipe. See Table 2 – Approximate Squeeze-off and Release Times.

NOTE: If air temperature is below freezing, squeeze rate should be slowed to approximately 1 inch per minute of pipe's outside diameter.

Table 2 – New - Approximate Squeeze-off and Release Times.

Table has the squeeze rate and release rate for PE pipe 1/2 inch through 12 inches.

Language was revised to be consistent with manufacturer's instruction. The squeeze rate in the earlier versions of the O&M was incorrectly worded which resulted in a slower squeeze rate,

Table was added to provide the field with the information so they would not have to make a calculation.

1. Do Not over-squeeze the pipe.

1 a. - New – The correct stops limit the minimum gap to 70% times twice the wall thickness of the PE pipe for screw and hydraulic operated squeeze-off tools.

1 b.- New – The 1" CTS PE 2708 pipe requires a pipe gap for 0.099 inches wall thickness.

1 c. - New - The 1" CTS PE 4710 pipe requires a pipe gap for 0.101 inches wall thickness.

5.2.5 - Revised - Operate the hand squeeze tool for PE pipe 2 inches or smaller in accordance with manufacturer's instructions.

1. – New - The correct stops limit the minimum gap to 85% times twice the wall thickness of the PE pipe for a hand squeeze-off tool such as a Timberline TC1-S.

5.3 Squeeze-Off Tool Removal

5.3.1 – Revised – When placing pipe back in service, slowly release the screw operated or hydraulic operated squeezer at approximately 0.5 inches per minute of pipe's outside diameter to allow the pipe to relax.

	<p>1. – New – If air temperature is below freezing, release rate should be slowed to approximately 0.25 inches per minute.</p> <p>5.3.2 – New – Hand squeeze tool shall be released in accordance with the manufacturer's instructions.</p> <p>The changes in PE pipe squeeze-off procedure were made to be consistent with Performance Pipe's PP801 – TN bulletin, Plastic Pipe Institute (PPI) TN 54 bulletin, ASTM F1563, and squeeze tool manufacturer's instructions.</p> <p>5.3.3 – After removing the squeeze tool:</p> <p>2. – New – Check for possible leaks, due to static electricity penetrating the pipe wall, with leak detection fluid.</p> <p>3. – Added "leaks" – If there are any leaks, cracks, cuts, or other indication of damage in the squeeze area, cut out and replace the damage section. Refer to REPR 1 Section 9.0 Polyethylene (PE) Pipe Repair.</p> <p>Squeeze tool manufacturer recommends checking for leaks in the squeeze area to ensure static electricity has not penetrated the pipe wall.</p> <p>6.0 Above Grade Squeeze</p> <p>6.1 – Added "and wall thickness" and "with gap stops"– The above squeeze tool shall have gap stops specific for the size of pipe and wall thickness.</p> <p>6.3 – Added "applying Ionix Static Suppressor to" – Applying the Ionix spray is not required when above grade squeeze tool is used.</p> <p>Reference Documents:</p> <p>Placed copies of the following in POLY 4:</p> <p>Plastic Pipe Institute "PE Pipe Squeeze-Off Compression and Release Times" Table.</p> <p>Performance Pipe PP801-TN Squeeze -Off.</p> <p>Linked Gas Standards SharePoint site – Specifications and Standards for:</p> <p>ASTM F1563 – Standard Specifications for Squeeze-Off Tools.</p>		
<p><u>POLY 2.5</u></p>	<p>Electrofusion</p> <p>15.0 Tapping</p> <p>15.3 Remove cap from the tee</p> <p>15.3.6 – Check the assembly for leakage. "Check" replaced "Test".</p>	<p>May 15, 2022</p>	<p>October 1, 2022</p>
<p><u>POLY 2.6</u></p>	<p>Mechanical Joining</p> <p>5.0 Stab Fittings</p>	<p>October 1, 2021</p>	<p>October 1, 2022</p>

UNCONTROLLED IF PRINTED

	<p>5.1 Stab fittings shall only be used on 1/2" through 1" PE pipe sizes.</p> <p>5.1.3 – Grammatical – An electrofusion coupling is required to 1" CTS PE 4710 pipe to the service riser pigtail on 1/2" through 1" PE service lines.</p>		
POLY 4	<p>Forms and Reference Materials</p> <p>Added:</p> <p>Manufacturers' Operating Instructions for AIC's Approved Squeeze-Off Tools.</p> <p>Performance Pipe PP 801-TN PE Pipe Squeeze-Off</p> <p>Plastic Pipe Institute PPI TN 54 – 2017 – Squeeze-Off PE Pipe</p> <p>Updated:</p> <p>Performance Pipe PP 750 Heat Fusion Procedures (June 2021)</p> <p>Removed all of the manufacturers' website links since so many of them were no longer valid links.</p>	May 15, 2022	October 1, 2022
PTST 1	<p>Requirements</p> <p>4.0 General</p> <p>4.6 – Grammatical – "main" replaced "pipeline segment"</p> <p>5.0 Safety</p> <p>5.1 – Avoid positioning anyone in the "line-of-fire"</p> <p>5.1.2 – Added – McElroy test cap has a maximum pressure rating of 165 psig. Refer to POLY 4 McElroy TP 300 Series Test Cap.</p> <p>7.0 Test Medium</p> <p>7.1 – Revised – Natural gas should only be used for Uprates and Tie-Ins.</p> <p>Concern here is the safety to the public and workers if natural gas is used to establish MAOP and there is leak or failure in the buried line. Upgrades require a leak survey at each pressure increase step that isn't required when establishing MAOP. Tie-Ins are check for leaks at the time for the tie-in.</p> <p>11.0 Plastic Pipe Testing</p> <p>11.1 Before testing</p> <p>11.1.1 – Correction – Do not test PE pipe if the temperature of the pipe is greater than 140°F.</p> <p>Performance Pipe limits the HDB at 140°F for both the PE2408 and PE4710. This a correction from 100°F. Part 192.513(d) has the 100°F or the temperature at which the material's long</p>	December 15, 2021	October 1, 2022

	<p>term hydrostatic strength has been determined, whichever is higher.</p> <p>11.2 – New – If McElroy Test Cap is being utilized, follow the manufacturer's operating instructions. Refer to POLY 4 McElroy TP 300 Series Test Cap.</p> <p>1. McElroy Test Cap is limited to a maximum test pressure of 165 psig.</p> <p>2. McElroy Test Cap shall not be used when testing HDPE for a MAOP of 125 psig.</p> <p>QA field audits were finding the use of these test caps was not following the manufacturer's instructions which are included in the POLY 4 Reference Material section. The recommendation was to include more specific information on these test caps with reference to manufacturer's instructions. In particular, following the pressure test, the end of the PE pipe where the test cap was attached was not being remove 1 inch beyond the where the safety lanyard had been located..</p>		
<u>PTST 1.1</u>	<p>Test Pressure and Duration Tables</p> <p>Appendix A-1 – Maximum test pressure for MDPE and HDPE with Design MAOP of 60 psig changed to 180 psig from 260 psig and removed reference to Note (3).</p> <p>Made this consistent with Appendix A-2.</p>	October 1, 2021	October 1, 2022
<u>PTST 3</u>	<p>Forms and Reference Materials</p> <p>Update – Hydrotest Strength Test Form</p>	December 15, 2021	October 1, 2022
<u>PUBL 0</u>	<p>Table of Contents</p> <p>PUBL 2.2 – Removed Section 8.0 Natural Gas Emergency Procedure.</p> <p>This section applies to Emergency Response Agencies who do not have access to the O&M. Instructions to these agencies is covered in face-to-face session with AIC's Public Education personnel.</p>	October 1, 2020	October 1, 2022
<u>PURG 1</u>	<p>Liaisons with Fire, Police, and Public Officials</p> <p>Remove Section 8.0 Natural Gas Emergency Procedure.</p>	May 15, 2022	October 1, 2022
<u>PURG 1</u>	<p>Requirements</p> <p>4.0 General</p> <p>4.1 Gas Engineering, GTE, or GSE will provide detailed purge plans prior to blowdown operations for:</p> <p>4.1.5 – Added – Joint abandonment of distribution mains and services.</p>	December 15, 2021	October 1, 2022

	<p>Added to be consistent with Appendix A – Purge Plan and Documentation Requirements.</p> <p>4.8 – Grammatical – "in gaseous environment" replaced "with blowing gas".</p> <p>6.0 Transmission Lines and High-Pressure Distribution Mains.</p> <p>6.2 – Grammatical – Added "drawdown" as a clarifier to "transferring".</p>		
<p><u>PURG 2</u></p>	<p>Methods</p> <p>4.0 Safety</p> <p>4.1 – Added – In general, this requires a vent pipe long enough to carry the gases above the heads of the workers on equipment located outdoors.</p> <p>Additional guidance on length of vent pipe. Field conditions and surrounding area will dictate a suitable length to avoid creating a hazardous situation or environment.</p> <p>6.0 Purging of Gas with Air During Abandonment</p> <p>6.2 – Correction – Do not exceed the MAOP or Operating Pressure at time for Stop.</p> <p>To avoid the potential for injecting air into a live gas system, the injection pressure should not exceed the pressure being restrained by the stopping equipment.</p> <p>7.0 Using an Inert Gas Slug when Purging</p> <p>7.3 – Removed this section that addressed how to calculate the volume in various size of cylinder to get a 1 psig pressure drop.</p> <p>This is a confusing section and difficult to understand or utilize. Operations typically does not utilize this method. Engineering is looking at alternative methods for determining the required volume for an inert plug.</p> <p>12.0 Venting of Gas</p> <p>12.1 - In general, this requires a vent pipe long enough to carry the gases above the heads of the workers on equipment located outdoors.</p> <p>Additional guidance on length of vent pipe. Field conditions and surrounding area will dictate a suitable length to avoid creating a hazardous situation or environment.</p> <p>12.2 – New – Refer to ACIG 2 Work Area Protection for placement of VEU or Compression System, such as ZEVAC, away from ignition sources.</p> <p>ZEVAC manufacturer recommends keeping the ZEVAC unit at least 15 feet away from an ignition source such as the gasoline/diesel engine</p>	<p>December 15, 2021</p>	<p>October 1, 2022</p>

	that provide the power the VEU and ZEVAC unit. This information was added to ACIG 2.		
--	--	--	--

<p><u>SAFT 1</u></p>	<p>Requirements</p> <p>2.0 Scope</p> <p>Appendices – Updated with new GTPC Guidelines for:</p> <p>Determination of Reporting Requirements for Safety-Related Conditions for Pipeline Facilities Other than Underground Natural Gas Storage Facilities;</p> <p>Determination of Reporting Requirements for Safety-Related Conditions for Underground Natural Gas Storage Facilities</p> <p>GTPC published updated Guidelines for reporting Safety-Related Conditions. Guidelines for Underground Natural Gas Storage Facilities are new.</p> <p>4.0 Regulatory Requirements</p> <p>4,1 Definition</p> <p>4.1.3 – Update Attachment 1 title - Pipeline Facilities Other than Underground Natural Gas Storage Facilities.</p> <p>4.1.4 – New - Refer to Attachment 2 Determination of Reporting Requirements for Safety-Related Conditions for Underground Natural Gas Storage Facilities for determining the requirements to report SRCs to PHM-SA, and IDNR.</p> <p>4.2 Pipeline facilities: Situations that may result in an SRC are as follows:</p> <p>4.2.6 – Grammatical – Removed reference to Class 1 leak and LEAK 1 Section 5.0.</p> <p>A pipeline leak that constitutes an emergency.</p> <p>Based on discussion with Compliance it was decide for consistency to utilize the Part 191.23 language.</p> <p>Attachments</p> <p>Updated with the new GTPC Guidelines</p>	<p>October 1, 2021</p>	<p>October 1, 2022</p>
<p><u>SERV 1</u></p>	<p>Requirements</p> <p>4.0 Depth of Service Line</p> <p>4.4. Underground structure conflicts with service line location:</p> <p>4.4.1. Item 3 c. – Removed – Safety Wrap is no longer being manufactured and there is no alternative product.</p> <p>7.0 Location</p> <p>7.1 Services</p> <p>7.1.2 – New – New, relocated, or replaced service lines shall not be installed under buildings unless:</p>	<p>May 1, 2022</p>	<p>October 1, 2022</p>

1. Installation is approved by Gas Engineering, AND
2. Service line is installed in a gastight casing to prevent gas leakage into the building, AND
3. Service line and casing must extend into a normally usable and accessible part of the building, AND
4. The casing vented to a nonhazardous atmosphere outside the building with a rain or insect resistant fitting.

This was the language in the Gas O&M for several years prior to the Rewrite project. It was inadvertently left out of the O&M since October 1, 2020. This procedural language is consistent with the Federal Code on service line installation.

7.2 Branch Service – New section

7.2.1 – Any branch service, installed on or after October 1, 2022, shall only serve 2 service risers from a single service line tap.

7.2.2 Each of the service lines shall meet the same requirements as a single service line.

7.2.3 SERV 2.2 Paragraph 4.1.2 addresses EFV requirements for branch services

Clarifies that a single service line can be split (branched) to serve a second riser on adjoining or adjacent premise. No more than two risers are to be served from a single service line tap.

7.3 Service Risers

7.3.2 – Revised – Alternate location would be a mutually agreed location that is readily accessible and meets the clearance requirements in Table 1 Meter Riser Clearance Requirements.

Language was revised to allow for more flexibility in the location of the service riser and meter set. It is important that the gas meter must be in a readily accessible location.

11.0 Pressure Testing - Added reference to 192.513

11.1 – Revised – All of the following shall be pressure tested in accordance with PTST 1 Section 10.0 Testing.

Removed reference to test medium since that is covered in PTST 1 Section 7.0.

Appendix A – Service Line Location

A-3 Residential Meter Set Locations Restrictions

Added Note – A 15 feet horizontal radius from the relief vent is required for gas risers greater than 2" IPS (2.375 inches in diameter).

UNCONTROLLED IF PRINTED

	<p>The National Electric Code and the AGA both recommend an increase in the clearance distance to potential ignitions sources for risers greater than 2"IPS due the potential of a release of a larger volume of gas. There is an effort to standardized AIC's Electric and Gas Service Standards so that they both meeting applicable Code requirements and recommendations.</p> <p>Appendix B-1 through B-5: PE3408/PE4710 service lines: Added – but can be installed in systems with MAOP less than 61 psig.</p> <p>Clarifies that PE3408/PE4710 service line pipe can be installed in lieu of PE2406/PE2708 in systems with MAOP of 60 psig or less. This is already occurring in some areas due to preference or supply shortage of the MDPE pipe.</p> <p>Appendix B-3 – 1" PE Service Line, Flex Riser Inserted new Item 7 – The EFV can be butt fused to the service tee outlet and PE 2708 or PE 4710 service line.</p> <p>Appendix B-4 - 1" PE Service Line, Rigid Riser Inserted new Item 7 – The EFV can be butt fused to the service tee outlet and PE 2708 or PE 4710 service line.</p> <p>Allows Operations or contractors that have 1 inch butt fusion equipment to butt fusion in lieu of electrofusion the EFV connection.</p>		
<p><u>SERV 2.3</u></p>	<p>Farm Tap</p> <p>4.0 Farm Tap Requirements</p> <p>4.1 – MAOP replaces operating pressure</p> <p>Former 4.5 – Removed, same information as 4.1</p> <p>6.0 Farm Tap Installation</p> <p>6.1 Farm Tap Type</p> <p>"MAOP" replaces "operating pressure"</p> <p>Appendix A-1 – MAOP replaced Pressure</p> <p>Appendix A-2 – MAOP replaced Pressure</p> <p>Bill of Material – Item 19 Riser – Corrected riser description to match Appendix A-1.</p>	<p>February 22, 2022</p>	<p>October 1, 2022</p>
<p><u>SERV 2.7</u></p>	<p>Gas Service Card Form and Gas Sketch Card</p> <p>5.0 Service Sketches</p> <p>5.1 Service Sketch shall be completed</p> <p>5.1.6 – Grammatical - Partially retired when 18 inches or longer of existing pipe remains connected to source of gas.</p> <p>5.2 – Revised – The following information shall be provided in ClickMobile:</p>	<p>May 15, 2022</p>	<p>October 1, 2022</p>

UNCONTROLLED IF PRINTED

	<p>5.2 NOTE – Indicates what information is required on a hand drawn sketch that is attached to the Work Order.</p> <p>Appendix A – Added – Information listed below should be entered within ClickMobile.</p> <p>Clarifies the information is entered within Click-Mobile and not both ClickMobile and Sketch Card.</p>		
<u>STLP 0</u>	<p>Table of Contents</p> <p>STLP 2.3 Steel Pipe: Squeeze_Off – New Section</p> <p>STLP 4.0 Forms and Reference Material – New Section</p>	October 1, 2020	October 1, 2022
<u>STLP 1</u>	<p>Requirements</p> <p>12.0 Pipe Thread Sealers</p> <p>12.1 – Added Stock Code for gas thread tape.</p>	October 1, 2021	October 1, 2022
<u>STLP 2.3</u>	<p>Steel Pipe Squeeze-Off - New</p> <p>Describes basic procedures for squeezing steel pipe in emergency situations when an immediate shut-down of gas flow is required to minimize an imminent hazard to life or property.</p> <p>The O&M did not have procedures for squeezing steel pipe. The squeeze tool manufacturer's instructions will provide additional procedures for utilization of the specific squeeze tool.</p>	New	October 1, 2022
<u>STLP 4</u>	<p>Forms and Reference Materials</p> <p>Manufacturers' instructions provided for:</p> <p>Huskie PS-62B</p> <p>Huskie PS-75</p> <p>Footage C170-A2</p> <p>Regent Model 5045T</p> <p>Regent Model 5230T</p>	New	October 1, 2022
<u>TAPS 0</u>	<p>Table of Contents</p> <p>New Section</p> <p>TAPS 2.8 Shim Installation</p>	October 1, 2020	October 1, 2022
<u>TAPS 2.4</u>	<p>Mueller Tapping and Stopping Procedures</p> <p>4.0 General</p> <p>4.8 – New – Shims are stock coded, 19 83 124, for use with 2" Mueller two-piece line-stopper fittings, for use on 1-1/4" IPS steel pipe.</p> <p>Appendix B-3 – Curb Valve Tee</p> <p>Pictures added for H-17800 and H-17900 with 2" square head.</p>	October 1, 2021	October 1, 2022
<u>TAPS 2.5</u>	<p>T.D. Williamson Tapping and Stopping Procedure</p>	December 15, 2021	October 1, 2022

	<p>2.0 Scope</p> <p>Appendices:</p> <p>Appendix D – Inserted - 3-Way</p> <p>Added Appendix F – ShortStopp 285 Purge and Equalization Fitting</p> <p>Appendix F – New – ShortStopp 285 Purge and Equalization Fitting</p>		
<u>TAPS 2.8</u>	<p>Shim Installation</p> <p>Instructions for installing shim on odd pipe sizes to allow for the installation of standard size line stopper fitting, i.e., 2" line stopper on 1-1/4" or 1-1/2" steel pipe.</p> <p>Procedures of the proper installation of shims has not been included in the O&M. The welding group prepared these instructions to provide for a standardized process for installing shims.</p>	N/A	October 1, 2022
<u>TAPS 3</u>	<p>Forms and Reference Materials</p> <p>Reference Materials</p> <p>Added:</p> <p>Shortstopp 275 and 500 Measurement Cards</p> <p>Shortstopp II 1.25 to 3 inch Measurement Cards</p> <p>Shortstopp II 4 to 12 inch Measurement Cards</p>	December 15, 2021	October 1, 2022
<u>TURN 0</u>	<p>Table of Contents</p> <p>TURN 2.4 Lighting Appliances</p> <p>Inserted new Section 7.0 Residential Boilers</p> <p>Shifted Vent-Free Appliances to Section 8.0</p> <p>Shifted Flame Characteristics to Section 9.0</p> <p>Shifted Appliance Safety to Section 10.0</p>	October 1, 2020	October 1, 2022
<u>TURN 2.1</u>	<p>Residential/Small Commercial Customer</p> <p>12.0 Lighting Appliances</p> <p>12.4 – New – Residential Boilers</p> <p>12.4.1 – New – Complete an inspection and operational check of the boiler. See TURN 2.4</p> <p>Section 8.0 Lighting Appliances: Residential Boilers.</p>	October 1, 2021	October 1, 2022
<u>TURN 2.4</u>	<p>Lighting Appliances and Checking Appliance Safety</p> <p>0. Scope</p> <p>Section 7.0 Residential Boilers - New</p> <p>4.0 Lighting Appliances: Stoves (Ranges)</p> <p>4.3 – Operational Check – Range Top Burners</p> <p>4.3.4 – Updated link to Section 9.0 Flame Characteristics.</p>	October 1, 2021	October 1, 2022

	<p>4.4 Operational Check – Oven Burner</p> <p>4.4.2 – Item 2 a. (i) – Updated link to Section 10.0 Appliance Safety.</p> <p>4.4.3 - Updated link to Section 9.0 Flame Characteristics.</p> <p>5.0 Lighting Appliance: Water Heater</p> <p>5.5 Operational Check for Conventional Water Heater</p> <p>5.5.4 - Updated link to Section 10.0 Appliance Safety.</p> <p>5.5.8 - Updated link to Section 9.0 Flame Characteristics.</p> <p>6.0 Lighting Appliances: Furnaces</p> <p>6.2 Prohibited Installations</p> <p>6.2.5 – Updated link to Section 8.0 Vent-Free Appliances.</p> <p>6.4 Operational Check</p> <p>6.4.2 - Updated link to Section 10.0 Appliance Safety.</p> <p>6.4.7 - Updated link to Section 9.0 Flame Characteristics.</p> <p>7.0 Boilers – New Section</p> <p>This section outlines procedures for inspecting, and lighting of an existing boiler after fuel lines have been purged of air.</p> <p>Includes sections on:</p> <p>Prohibited Installations</p> <p>Visual Inspection</p> <p>Operational Check</p> <p>Inspecting and lighting residential boilers are covered in gas training but was not included in the O&M.</p>		
<p><u>VALV 1</u></p>	<p>Requirements</p> <p>5.0 Emergency Valves Locations</p> <p>5.5 Records</p> <p>5.5.1 – Item 2 – Maximo replaced Gas Compliance System</p>	<p>October 1, 2021</p>	<p>October 1, 2022</p>
<p><u>VALV 2.2</u></p>	<p>Valve Inspection, Maintenance, and Repair</p> <p>Appendix A – Plug Valve Maintenance</p> <p>Appendix A-3 – Valve Cleaners</p> <p>A-3.1 – Revised – Proper lubrication in not possible until the cleaning process has been completed, unless the valve is maintained annually as an emergency valve</p> <p>A trainer pointed that on annually maintained valves, cleaners are not necessary because the</p>	<p>October 1, 2021</p>	<p>October 1, 2022</p>

	<p>valves are being operated should keep the lubricant from becoming stiff.</p> <p>A-7 Lubrication Gun will not build pressure</p> <p>A-7.4 – Added "injection"</p> <p>Clarification that it is the injection pressure that should be kept above 1500 psi.</p> <p>Appendix B Keotest Gas Valve Maintenance</p> <p>B-1 General</p> <p>B-1.2 – New – Kerotest recommends installing packing shims as a first attempt to stop a stem packing leak. The procedure can be found in VALV 4 Kerotest Model-1 Gate Valve Operations Manual.</p> <p>Gas Trainer felt Kerotest's recommendation needed to be added to our procedures.</p>		
<p><u>VALV 3</u></p>	<p>Approved Valves and Valve Box Accessories</p> <p>VALV 3 has completely been revised:</p> <p>All of the valve dimension tables have been removed. Refer to manufacturer's website for product information on valve dimensions.</p> <p>Several new PE, Steel Ball, and Gate valves have been.</p> <p>Each Valve Class150 and Class 300 Table has been reformatted to include all connection types</p> <p>Class 150 and Class 300 Cameron and Balon Trunnion Mounted Valves have been added.</p> <p>Valve dimension tables were removed because ensuring the information is correct was becoming difficult. Various dimensions change with each manufacturer's product update. Consultation with some engineering personnel found that most use the manufacturers' website if dimensions are needed.</p>	<p>May 15, 2022</p>	<p>October 1, 2022</p>
<p><u>WELD 2.3</u></p>	<p>Construction of Pipelines</p> <p>9.0 Welding Requirements</p> <p>9.2 Line-Up and Fit-Up of Butt Welds</p> <p>9.2.1 – Added a NOTE:</p> <p>NOTE:</p> <p>If welders are going to cut out a section of a bar, it should be approximately 1 inch in width with no more than 2 bars cut for every 6 bars in the clamp.</p> <p>Clamp manufacturers provided this guideline as to what is an acceptable modification.</p>	<p>October 1, 2020</p>	<p>October 1, 2022</p>

	QA has reported bars being removed from clamps so that welder does not have to stop and start the root bead as often.		
<u>WELD 2.6</u>	<p>Radiographic Testing</p> <p>5.0 Radiographic Testing Personnel</p> <p>5.2. – Revised – All other RT personnel assigned to and engaged in assisting the Level II or Level III radiographer in the production of radiographs shall have a State of Illinois' Industrial Radiographer Certification Card.</p> <p>RT companies do not have a specific training program for the helpers but do require them to have this Illinois certification card.</p>	December 15, 2021	October 1, 2022
<u>WELD 2.7</u>	<p>Magnetic Particle Testing</p> <p>5.0 Magnetic Particle Testing Personnel</p> <p>5.2 – Removed</p> <p>Magnetic particle testing is a one-person operation and does require an assistant or trainee so there is no need to require specific training requirements for those positions.</p>	December 15, 2021	October 1, 2022
<u>WELD 2.8</u>	<p>Liquid Penetrant Testing</p> <p>5.0 Liquid Penetrant Testing Personnel</p> <p>5.2 – Removed</p> <p>Liquid penetrant testing is a one-person operation and does require an assistant or trainee so there is no need to require specific training requirements for those positions.</p>	December 15, 2021	October 1, 2022

Document Rescission

SUMM - Change Summary, May 15, 2022.

UNCONTROLLED IF PRINTED

UNCONTROLLED IF PRINTED

Complete Change Summary			
Docu- ment	Change Summary	Previous Document Dated	Current Document Dated
<u>FORW</u>	Updated Contact Names and Information	December 15, 2021	May 15, 2022
<u>APPR 2.01</u>	<p>Gas Journeyman</p> <p>Updated Gas Journeyman Training Curriculum</p> <p>2. A. – Added "& Safety"</p> <p>2. A. (6) – Distribution of CF33s and Introduction of O&M Plan and Field Safety Manual</p> <p>2. A. (7) – Added – Basic Gas Safety</p> <p>2. A. (8) – Added – Basic Excavation Safety</p> <p>2. A. (9) – Added – Understanding Job Briefings</p> <p>2. A. (10) – Added – Rubber Glove Testing Procedures</p> <p>2. B. (7) – Updated Covered Task Titles</p> <p>2. C. (1) – Removed Installation of PE Pipe</p> <p>2. C. (5) – Removed Squeezing Plastic Pipe</p> <p>2. C. (6) – Removed Pressure Testing</p> <p>2. C. (7) – Removed Service Transaction Documenta- tion</p> <p>2. E. – Updated to Working in Gaseous Environment</p> <p>2. E. (4) – Supplied Air replaces Breather Box</p> <p>2. F. – New Section – Critical Thinking & Problem Solving</p> <p>2. G – New Section - Maps, Symbols & Documenta- tion</p> <p>2. I. (7) – New – Subsurface Electrical Hazards</p> <p>2. J. (8) – New – Gas Meter Data Sheets</p> <p>2. M. – "and Repair" replaces "of Distribution System"</p> <p>3. Additional Training (As needed) section removed</p> <p>5. OJT Breakdown:</p> <p>PE Installation – Added - 0571 – Pressure Test ≥ 100 psig</p> <p>Steel Installation – Correction in 0571 - ≥ 100 psig</p> <p>Appliance Relights/Turn-ons – 1201, Temporary Isola- tion of Service Lines and Service Discontinuance</p>	October 1, 2020	May 15, 2022
<u>BORE 2.1</u>	<p>Boring Operations and Pipe Installation</p> <p>Throughout the document – spelling correction – pot- hole or potholes</p> <p>4.1.1 Item 1. – Machine operators</p>	October 1, 2021	May 15 2022

	<p>4.1.1 Item 2. – Locators</p> <p>4.2.3 – "precautions" replaces "precaution"</p> <p>Replaced singular with plural.</p> <p>4.2.3 Item 5. – "boring operations" replaces "covered work"</p> <p>4.3.3 – Correction – Potholes shall</p> <p>4.3.3 Item 1. – Inserted "on"</p> <p>5.6 – "under undue stress" replaces "in undue stress"</p> <p>6.10 – Removed commas</p> <p>7.2 – "Entrance and exit" replaces "Exit and entrance"</p> <p>7.13 NOTE: "large diameter pipe" replaces "larger diameter pipe"</p>		
<u>CORR 2.1</u>	<p>Cathodic Protection Design</p> <p>4.1.6 – Added "an"</p> <p>8.4.1 Table 3 Insulating Unions – Correction – 150 psig replaces 175 psig and removed 500 psig column,</p> <p>Stock coded insulating unions are either Class 150 or rated at 3000 psig.</p>	December 15, 2021	May 15, 2022
<u>CORR 2.4</u>	<p>Cathodic Protection Criteria</p> <p>4.1.2 – Grammatical – "properly evaluating the measurement"</p> <p>Appendix A:</p> <p>3. C. – Spelling correction – half-cell</p> <p>3. C. (2) – Grammatical – In case of dry soil, add water to the half-cell placement site.</p> <p>4. B. – Added "Figure 2. Copper Sulfate Reference Cell"</p> <p>4. B. Table – Added "For M.C. Miller Half-Cell"</p>	October 1, 2020	May 15, 2022
<u>CORR 2.5</u>	<p>CP System Troubleshooting</p> <p>14.2 – Grammatical correction – "to create an "instant off" potential for the pipeline.</p>	October 1, 2020	May 15, 2022
<u>CORR 2.8</u>	<p>Cathodic Protection Testing</p> <p>4.2 – Spelling correction – half-cell</p> <p>4.2.4 - Spelling correction – half-cell</p> <p>Subsection 5.1 – Grammatical correction –pin instead of probe. Rearranged the order; four pin, single pin and soil box.</p> <p>11.1.1 – Spelling correction – half-cell</p> <p>Appendix A-1 Flush To Grade Test Station – Corrected Stock Code, 19 12 703, and Description of Test Box.</p> <p>Update description of the Pipeline Marker Test Stations in:</p> <p>Appendix A-2 - Above Grade Test Station</p>	December 15, 2021	May 15, 2022

	<p>Appendix A-3 – Foreign Pipeline Crossing Test Station</p> <p>Appendix A-4 – Inline Insulator Above Grade Test Station</p> <p>Appendix B – Test Lead Wire Attachment</p> <p>2. Figure – Typical Thermite Weld Configuration</p> <p>4. A. – Reformatted Cadweld Thermite Weld Items chart.</p> <p>4. B. - Reformatted CadWeld Plus Items chart.</p> <p>5. Picture – Added – Pin Brazing Equipment</p> <p>5. G. - Moved Brazing Pins & Ferrules to under picture</p> <p>5. G. – Reformatted Pin Brazing Item Table</p> <p>5. G, Note below Table – Added Website address</p> <p>6. A. – Added Welded Bolt Connection below drawing</p> <p>7. B. – Added Viscolaq Coating Patch under pictures</p>		
<u>CORR 3</u>	<p>Forms and Reference Materials</p> <p>Reference Materials: Added</p> <p>Denso SeaShield 525 Epoxy Coating</p> <p>Denso SeaShield 526 Epoxy Coating</p>	October 1, 2021	May 15, 2022
<u>EMER 2.1</u>	<p>Customer Care Center</p> <p>5.10.2 – Grammatical – arrives replaced arrived</p> <p>6.2.2 – Grammatical – the word "is" was inserted.</p> <p>8.2.3 – CO calls processed at priority level 8.</p> <p>8.4 – Removed "and that it will be given the same priority as a gas leak."</p>	October 1, 2020	May 15, 2022
<u>EMER 2.2</u>	<p>Dispatch Center</p> <p>7.3 Table 1 – Updated GTS Contact information. This was missed in the December 15, 2021 electronic Update.</p>	April 1, 2021	May 15, 2022
<u>EMER 2.3</u>	<p>Emergency Responder</p> <p>6.0 Note – Customer Care Center replaces Call Care Center</p>	April 1, 2021	May 15, 2022
<u>INCD 1</u>	<p>Incident Reporting</p> <p>Appendix D Table 1 – Corporate Claims</p> <p>Name update – Nikki Jenkins</p> <p>Added – Tabitha Bono</p> <p>Updated phone numbers</p> <p>Appendix D Table4 – Clinical Collection Management</p> <p>Removed Kenneth Sowers who retired</p>	December 15, 2021	May 15, 2022
<u>INVE 2.3</u>	<p>Investigation of Failures</p> <p>5.3 – Updated mailing address to Collinsville for failed material</p>	October 1, 2020	May 15, 2022

<p><u>LEAK 2.1</u></p>	<p>Indoor Leak Investigation 2.0 Scope – Appendices Appendix A – added Screen 65 Appendices – Appendix – added Screen 65 Appendix A – Updated the OAS 62, 63, 65, 6F and 6H Screen shots</p>	<p>October 1, 2021</p>	<p>May 15, 2022</p>
<p><u>LEAK 2.2</u></p>	<p>Outdoor Leak Investigation 11.0 – Records 11.4 – Added reference to LEAK 2.1 Appendix A for samples of OAS 62, 63, 65, 6f and 6H Screens</p>	<p>October 1, 2021</p>	<p>May 15, 2022</p>
<p><u>LEAK 3</u></p>	<p>Forms and Reference Materials Updated – Leak Investigation Form Added – ClickMobile Leak Investigation Form</p>	<p>October 1, 2021</p>	<p>May 15, 2022</p>
<p><u>MAIN 1</u></p>	<p>Requirements 10.2.3 – Removed – Repeat of 10.2.2</p>	<p>December 15, 2021</p>	<p>May 15, 2022</p>
<p><u>MAIN 2.2</u></p>	<p>Lowering or Realignment of Pipe 4.2.1, Item 2 – Updated - PE pipe with Design MAOP of 125 psig replaces 100 psig. MAOP for HDPE was changed to 125 psig in October 1, 2021.</p>	<p>October 1, 2021</p>	<p>May 15, 2022</p>
<p><u>MAIN 2.4</u></p>	<p>Temporary Pipeline Support 4.2.1 – Updated – Gas Region Engineering 4.2.1, Item 2 - Updated - PE pipe with Design MAOP of 125 psig replaces 100 psig. MAOP for HDPE was changed to 125 psig in October 1, 2021.</p>	<p>October 1, 2020</p>	<p>May 15, 2022</p>
<p><u>MAIN 2.5</u></p>	<p>Pipe Coating and Gasket Removal Reference Documents – Updated WIGE 2.2 replaces WWBG 2.2 Appendix A – PPE – Updated Stock Codes for Gloves – North NF11: red vinyl-coated palms. Delete the XS size.</p>	<p>December 1, 2020</p>	<p>May 15, 2022</p>
<p><u>METR 2.2</u></p>	<p>Meter Inspection and Testing – Field 7.0 Meter Header Inspection 7.2 AC Voltage on Meter Set 7.2.2 – Updated Stock Code, 60 05 635, for the Klein Previous Stock Code 65 36 383 is now being directed to this other Stock Code which has the same P/N.</p>	<p>December 15, 2021</p>	<p>May 15, 2022</p>
<p><u>ODOR 2.1</u></p>	<p>Odorant Intensity Sampling and Testing</p>	<p>April 1, 2021</p>	<p>May 15, 2022</p>

	Reference Documents – Correct link to Heath Odorator Manual		
OQAL 4	Forms and Reference Materials Ameren Illinois Contractor Hiring Checklist – Jennifer Modesto replaces retired Kenneth Sowers.	October 1, 2021	May 15, 2022
PCBH 0	Table of Contents Correction – PCBH 2.0 Sampling Liquid from Gas Pipeline Systems	October 1, 2021	May 15, 2022
PCBH 1	Requirements 4.5 – Grammatical – inserted "with" Section 6.0 – Ameren Laboratory Services replaces Ameren's UEC – Laboratory Services	October 1, 2021	May 15, 2022
PCBH 2.1	Positive PCB Detection 5.3.8 – Added PCBH 2.0 Subsection 6.1 link to Spill Hot Line phone number	October 1, 2021	May 15, 2022
PCBH 2.3	Liquid Release Protocol 5.2.5 – Hyperlink PCBH 2.0 Subsection 6.1 – replaces Spill Hot Line phone number. 6.2.5 - Hyperlink PCBH 2.0 Subsection 6.1 – replaces Spill Hot Line phone number.	October 1, 2021	May 15, 2022
PCBH 2.4	Wipe and Soil Sampling Throughout document: Ameren Laboratory Services replaces Ameren's UEC – Laboratory Services	October 1, 2021	May 15, 2022

PMRK 2	Pipeline Facility Markers Appendix B-4 – River Crossing Sign 3a. - Electronic version was missing "Illinois" in front of River	October 1, 2021	May 15, 2022
POLY 2.1	Design Pressure Appendix A-1 – PE2708 Table – 1/2" & 1" CTS Appendix A-2 – PE 4710 – 1/2" & 1" CTS CTS pipe does not carry a manufacturer's SDR rating. The SDR rating shown in the tables is a calculated equivalent. Note added below both tables: CTS pipe print line contains the minimum wall thickness. It does not show a SDR rating. The SDR shown in this table is a calculated equivalent SDR.	December 15, 2021	May 15, 2022
POLY 2.2	Squeeze Off	October 1, 2021	February 4, 2022

	<p>A Gas Standards Update was issued on February 4, 2022, making the following change effective immediately.</p> <p>5.2.4 – Operate the screw and hydraulic operated tools in a slow continuous manner, approximately 1 minute per inch of pipe's designated diameter (i.e., 1" CTS, 2" IPS), to relieve pipe stresses.</p> <p>NOTE: PE service lines, 2 inch and smaller, can be squeezed-off with hand operated squeeze-off tools such as" Timberline TC1-S or vise grip style squeezer. The tool shall be designated for the pipe size and wall thickness being squeezed.</p> <p>CAUTION: 1" PE 2708 requires a squeezer marked: wall thickness 0f 0.099".</p> <p>1" PE 4710 requires a squeezer marked: wall thickness 0.101"</p>		
POLY 2.5	<p>Electrofusion</p> <p>9.2.2 – Correction PE 4710 1" CTS SDR 11.1</p> <p>Reference Documents – Link to POLY 4 for MSA 340 Manual replace invalid website link.</p> <p>Appendix B-1 – Removed Central Plastic website link which is no longer valid.</p>	December 15, 2021	May 15, 2022

,

POLY 4	<p>Forms and Reference Materials</p> <p>Updated:</p> <p>IPEC Genesis F3 Operators Manual</p> <p>McElroy Line Tamer Manual</p> <p>Added:</p> <p>McElroy 28 Fusion Machine Operator's Manual</p> <p>Removed all of the manufacturers' website links due to difficult in ensure links are active.</p>	December 15, 2021	May 15, 2022
PUBL 2.2	<p>Liaisons with Fire, Police and Public Officials</p> <p>8.2.6 Item 1 – Remove – You can turn off gas service at the meter.</p> <p>Appendix A – Sample Letter – Jacob Dukett's contact information replaces Tina Meehan's</p> <p>Appendix B – Sample Operator Page - Updated</p>	October 1, 2021	May 15, 2022
PURG 0	<p>Table of Contents</p>	December 15, 2021	May 15, 2022

UNCONTROLLED IF PRINTED

	PURG 2.0 Section 15 - Corrected spelling - Compression		
<u>QUAL 1</u>	<p>Requirements</p> <p>2. D. – Removed – Since Construction Inspectors and Gas Supervisors do not preform Quality Assessments</p>	October 1, 2021	May 15, 2022
<u>SECR 1</u>	<p>Requirements</p> <p>5.1 – Updated – Ameren Security Operations Center</p> <p>6.5 – Replaces 6.4.4 – Moved Director's responsibly to its own Subsection.</p> <p>Resource Documents:</p> <p>Removed Ameren Gas Facilities Corporate Security Plan. This is not a publicly available document.</p>	October 1, 2020	May 15, 2022
<u>SERV 1</u>	<p>Requirements</p> <p>4.0 – Moved from 4.1 - Code reference 49 CFR §192.361.</p> <p>5.0 – Added Code reference 49 CFR §192.361.</p> <p>8.1.2 – Item 1. - Replaced with former 1a. – Reference to SERV 2.2 for EFV requirements.</p> <p>10.0 - Added Code reference 49 CFR §192.321.</p> <p>11.0 – Added Code reference 49 CFR §192.511.</p> <p>12.1 – Added "until customer is supplied with gas".</p> <p>Appendix B-3 PE 3408/ PE 4710 1" Service Line – Both Flex Riser and Rigid Riser Standards.</p> <p>Installation – Item 5 – added - 0.101 wall thickness, equivalent to SDR 11.1</p>	October 1, 2021	May 15, 2022
<u>SERV 2.3</u>	<p>Farm Tap</p> <p>A Gas Standards Update was issued on February 22, 2022, making the following change effective immediately.</p> <p>Unless there is an operational need or directive from Integrity Management, the appropriate non-inspectable farm tap may be installed instead of the Double Cut DOT Transmission farm tap.</p> <p>As a result of this change, all references to the DOT Transmission farm tap is being removed and the Appendix A-3 will be removed.</p>	October 1, 2021	February 22, 2022
<u>SERV 2.7</u>	<p>Gas Service Card Form and Gas Sketch Card</p>	December 15, 2021	May 15, 2022

	4.0 – Added Code references 49 CFR§191.11, 49 CFR§192.383		
<u>STLP 2.2</u>	<p>Design Pressure</p> <p>Appendix A – Additional stock coded pipe listed</p> <p>Appendix A Note (6) – Updated the Gas Standards and Procedures SharePoint site and link to the Specifications & Standards</p>	April 1, 2021	May 15, 2022
<u>VALV 0</u>	<p>Table of Contents</p> <p>VALV 3 – Section 6.0 – Spelling correction - Kerotest Gate Valves</p> <p>VALV 3 – Section 7.0 –Valve Box Accessories Stock Code Table (Removed – between Stock and Code)</p>	October 1, 2020	May 15, 2022
<u>VALV 3</u>	<p>Approved Valves and Valve Box Accessories</p> <p>2.0 Scope:</p> <p>Section 6.0 – Spelling correction - Kerotest Gate Valves</p> <p>Section 7.0 –Valve Box Accessories Stock Code Table</p> <p>Removed Steel Plug Valves section</p>	December 15, 2021	May 15, 2022
<u>WIGE 2.2</u>	<p>Personal Protective Equipment</p> <p>4.0 Table 1 – Copied the approved PPE Table from Gas Standards & Procedures SharePoint site. Updated 07/06/2021</p>	April 1, 2021	May 15, 2022

Variable "version" is not defined

CHANGE SUMMARY

December 15, 2021

Document	Change Summary	Previous Document Date	Current Document Date
	<p>Changes due to Regulatory Updates or Operational Requests</p>		
<p>INCD 1</p>	<p>Requirements</p> <p>10.2.4 Retracting reports</p> <p>1. – Updated – PHMSA no longer request operators to retract erroneously reported 1 Hour or 48 Hour NRC Notification Reports.</p> <p>2. – New – If an incident is subsequently determined to be caused by non-jurisdictional piping, an email is sent to PHMSA and ICC, prior to the 30 day report requirement, advising that AIC will not be submitting a 30 day report.</p> <p>3. – Updated the process for requesting that the 30 day report be retracted when further investigation reveals a reported incident was not an incident.</p> <p>4. – Is the former Item 3 which addresses notification to ICC and AIC internal recipients of the 30 day report.</p> <p>PHMSA General Instructions for Incident Report</p>	<p>October 1, 2021</p>	<p>December 15, 2021</p>
<p>LEAK 1</p>	<p>Requirements</p> <p>5.0 Leak Detection and Classification</p> <p>5.9 – New- Leaks identified during routine work activities shall follow the same classification procedures outlined in this procedure.</p> <p>PIPE's Act 2020</p>	<p>October 1, 2021</p>	<p>December 15, 2021</p>
<p>MAIN 1</p>	<p>Requirements</p> <p>2.0 Scope</p> <p>Inserted new Section 18.0 Design Considerations</p> <p>18.0 Design Considerations</p> <p>18.1 When designing a new pipeline or replacement project, care should be taken to consider safety of the public and co-workers as a top priority. Considerations include:</p> <p>18.2 Additional considerations should be taken for the protection of the environment. Considerations include:</p>	<p>October 1, 2021</p>	<p>December 15, 2021</p>

UNCONTROLLED IF PRINTED

	<p>18.3 Prone-to-leak facilities should be considered for replacement opportunistically and on a program level based on risk results. These include:</p> <p>PIPE's Act 2020</p>		
METR 1	<p>Requirements</p> <p>6.0 Meter Location</p> <p>6.3 Unacceptable Meter Locations</p> <p>6.3.10 – Where the service regulator vent is:</p> <p>4. Added – BelGas P100SX and PF FE 25 as approved slam-shut regulators.</p> <p>October 1, 2021 Update did not list the approved regulators.</p> <p>8.0 Regulator Vent Lines</p> <p>8.2 All relief vent lines shall be the same diameter, or larger, than the regulator vent opening.</p> <p>8.2.1 – increase the relief vent diameter one pipe size for every 10 feet to minimize flow restriction.</p> <p>1. New – The 10 feet may include up to 4 threaded fittings, (elbows, tees, etc.).</p> <p>2. New – If more than 4 threaded fittings are needed in the relief vent line, contact engineering for support.</p> <p>Clarification of a FAQ, the equivalent pipe footage of an elbow is not to be included in the 10 feet. (Equivalent pipe footage of 1" elbow is 2.6 feet.)</p>		
PURG 1	<p>Requirements</p> <p>4.0 General</p> <p>4.2 New – When planning projects, consider options to eliminate hazards and minimize the release of natural gas. See MAIN 1 Section 18.0 Design Considerations.</p> <p>PIPE's Act 2020</p>	October 1, 2021	December 15, 2021
PURG 2	<p>Methods</p> <p>2.0 Scope</p> <p>New Section 15.0 Use of Compression System</p> <p>15.0 Use of Compression System</p> <p>15.1 As determined by engineering, a compression system, such as a ZEVAC system, may be used to reduce the amount of natural gas released to the atmosphere.</p> <p>15.2 Only rated compressors may be used.</p> <p>15.3 Prior to compressing gas, engineering shall develop procedures outlining:</p> <p>Volume of gas, expected time for drawdown, expected final pressure, pressure monitoring plan and connection points.</p>	October 1, 2021	December 15, 2021

UNCONTROLLED IF PRINTED

PIPE's Act 2020			
PURG 3	<p>Forms and Reference Materials Added</p> <p>Zevac Operator's Manual</p> <p>Zevac Operator's Manual - Mini</p>	October 1, 2020	December 15, 2021
SERV 2.7	<p>Gas Service Card Form and Gas Sketch Card</p> <p>4.0 Gas Service Card Form</p> <p>4.1 – Revised – The Gas Service Card Form shall be completed within ClickMobile by gas field personnel.</p> <p>4.2 – Clarifications:</p> <p>4.2.2 – Replacement of gas service – total or partial</p> <p>4.3 – Information utilized in annual service report to PHMSA</p> <p>4.3.1 – New – The number of services installed and retired information is utilized in the annual service report to PHMSA</p> <p>4.3.2 – New – The number of EFV and manual service line shut-off valve installations are included in the annual report to PHMSA.</p> <p>4.4 – Update – GIS Discrepancy in ClickMobile is used to correct existing service attributes such as pipe size, pipe material, and connection to correct gas main.</p> <p>5.0 Service Sketches</p> <p>5.1 Service Sketch shall be completed in Click-Mobile for all service installations that are:</p> <p>5.1.2 – Clarified – Replaced total or partial.</p> <p>5.1.3 – Relocated replaces Modified.</p> <p>5.1.4 – New – Extending existing service line.</p> <p>5.1.5 – Clarified Repaired – when new section of pipe is installed.</p> <p>5.1.6 – Clarified Retired – when 18" or longer of existing pipe remains connected to source of gas.</p> <p>5.2 – Information shall be provided with sketch:</p> <p>5.2.10 – New – Measurement indicating the overall service length shall be included on the sketch.</p> <p>5.2.11 – New – A minimum of 2 measurements from the service tee to other points of reference shall be included on the sketch.</p> <p>1. Acceptable points of reference include: There are 9 points listed, 1a. through 1i.</p> <p>Example 1 – New – Sample of sketch with measurements shown</p>	October 1, 2020	December 15, 2021

	<p>Example 2 – New - Sample of sketch with measurements in text.</p> <p>6.0 Gas Sketch Card Completion instructions</p> <p>6.2 – Updated – The information listed under Subsection 5.2 shall be included with the Gas Sketch Card.</p> <p>Appendix A – Sample of Gas Sketch Card Added – Sketch shall follow the instructions in Paragraph 5.2.10 and Paragraph 5.2.11.</p> <p>Operational Update – Provides additional instructions on completing required service sketches.</p>		
	<p>Corrections & Minor Changes to October 1, 2021 O&M Update</p>		
CORR 2.1	<p>Cathodic Protection Design</p> <p>8.4 Insulator Unions</p> <p>Table 3 – Corrected Stock Code for 2", 175 psig, union.</p>	October 1, 2021	December 15, 2021
CORR 2.8	<p>Cathodic Protection Testing</p> <p>Appendix B Test Lead Wire Attachment</p> <p>7. Test Lead Attachment Coating</p> <p>7. A. – Cold Applied Butyl 35 or H35 tapes replace Wax Tapes</p>	October 1, 2021	December 15, 2021
LEAK 1	<p>Requirements</p> <p>Updated Appendix B – Leak Process Flow Chart wording:</p> <p>Below Grade Leaks – Under Pavement Extending to Foundation Wall</p>	October 1, 2021	December 15, 2021
LEAK 2.4	<p>Leak Surveys</p> <p>9.0 Unprotected Steel Lines</p> <p>NOTE should have been removed.</p>	October 1, 2021	October 1, 2021
LEAK 2.8	<p>Survey Maps and Records</p> <p>Typo correction in Paragraph 5.6.1 – add "be" between "shall" and "maintained".</p>	October 1, 2021	October 1, 2021

<p>METR 2.2</p>	<p>Meter Inspection and Testing – Field</p> <p>7.2 AC Voltage on Meter Set</p> <p>7.2.2. – New stock coded volt stick – Klein Model NCVT-4IR, a non-contact voltage tester with infrared thermometer.</p> <p>Added a Caution note: Volt stick models NCVT-3 or NCVT-3P can continue to be used, but take care to select the lower voltage when using a volt stick with voltage ranges.</p>	<p>October 1, 2020</p>	<p>December 15, 2021</p>
<p>METR 3.2</p>	<p>Regulator Sizing</p> <p>Appendix A - Regulators for New Installations @ 7" w.c. Delivery</p> <p>Correct orifice size is missing in the electronic version for the 1"x 1" Itron B42R and American 1813C, Stock Code 62 06 493</p>	<p>October 1, 2021</p>	<p>December 15, 2021</p>
<p>METR 4</p>	<p>Forms and Reference Materials</p> <p>Updated References for Fisher CS400 & CS800; Itron B31, B34, B43, CL31 that were missed with October 1 Update</p> <p>Added:</p> <p>BelGas P100SX Operating Manual</p> <p>PF FE 25 Operating Manual</p>	<p>October 1, 2021</p>	<p>December 15, 2021</p>
<p>POLY 2.1</p>	<p>Design Pressure</p> <p>4.0 Design Pressure</p> <p>4.3.4 – Correction – Pipe manufactured on or after January 22, 2019.</p> <p>October 1, 2021 Update had January 1, 2019.</p>	<p>October 1, 2021</p>	<p>December 15, 2021</p>
<p>POLY 2.5</p>	<p>Electrofusion</p> <p>Scope:</p> <p>Inserted new Section 11.0 – Electrofusion Tapping Tee Repair Kit Instructions. Instructions were moved from REPR 2.3 Leaking Aldyl-A Tee Caps section.</p> <p>Appendix A-10 – New – Kerotest Repair Kit for Aldyl-A Tee Caps includes Stock Codes.</p> <p>Information moved from REPR 2.3.</p>	<p>October 1, 2021</p>	<p>December 15, 2021</p>
<p>POLY 4</p>	<p>Forms and Reference Materials</p> <p>Updated IPEX Genesis F3 Operators Manual Rev 12</p>	<p>April 1, 2021</p>	<p>December 15, 2021</p>
<p>PTST 1</p>	<p>Requirements</p> <p>13.0 Components and Fabricated Unit/Assemblies</p> <p>13.1 – Removed "after installation"</p>	<p>October 1, 2021</p>	<p>December 15, 2021</p>

PTST 2.4	<p>Nitrogen Pressure Testing</p> <p>7.0 Cylinder Requirements</p> <p>7.1 – Replaced Figure 1 – Cylinder Estimation Graph that was mistakenly removed in October 1, 2021 Update.</p> <p>7.2 – Remove reference to Section 8.0 that was removed in October 1, 2021 Update.</p>	October 1, 2021	December 15, 2021
PTST 2.6	<p>ASME Pressure Vessels</p> <p>Appendix A – Corrected copy of Inspection of ASME Pressure Vessels Form</p>	October 1, 2021	December 15, 2021
PTST 3	<p>Forms and Reference Materials</p> <p>Forms:</p> <p>Added – Inspection of ASME Pressure Vessels Form</p>	October 1, 2021	December 15, 2021
REPR 0	<p>Table of Contents</p> <p>REPR 2.3 – Removed Section 7.0</p>	October 1, 2020	December 15, 2021
REPR 1	<p>Requirements</p> <p>Appendix C – Dresser Reinforcing Split Sleeve</p> <p>Table 2 – Dresser Style 220:</p> <p>Removed Stock Code 19 33 528 – 18"x38 ¾", 605 psig Sleeve.</p> <p>Changed 24"x 21 ¾", 645 psig Sleeve to Non-Stock</p> <p>Appendix G – Plexco Tapping Tee Replacement Cap</p> <p>Changed Style 1 Nipak and Extron Replacement Caps to Non-Stock</p>	October 1, 2021	December 15, 2021
REPR 2.2	<p>Plidco Split+Sleeve</p> <p>Appendix A-4 – Alternate 2</p> <p>Removed 10"x10 ½", 1,000 psig split+sleeve with Buna-N Packing</p>	October 1, 2021	December 15, 2021
REPR 2.3	<p>Leaking Aldyl-A Tapping Tee Cap</p> <p>2.0 Scope</p> <p>Removed Section 7.0 Installation Instructions</p> <p>4.0 General</p> <p>4.4 – New – Installation instructions are in POLY 2.5 Electrofusion.</p> <p>5.0 Repair Kit Components</p> <p>5.2 – Removed reference to Section 7.0</p> <p>7.0 Installation Instructions</p> <p>Removed. Moved to POLY 2.5 Electrofusion.</p>	October 1, 2020	December 15, 2021
SERV 2.2	<p>Excess Flow Valves or Manual Shut-off Valve</p> <p>Appendix B-1 through B-4 – Added values for Inlet Pressure of 125 psig.</p>	October 1, 2021	December 15, 2021

	Appendix B-5 – Added Red Text in the Maximum Length column that was added in October Update.		
--	---	--	--

<p>TAPS 2.3</p>	<p>Mueller AUTOPERF Tee 6.0 Maximum Pipe Wall Thickness For AUTOPERF Tee Corrected Stock Code Number for: Mueller H-18101, 3/4", 5/16" Perforator-1923192 Mueller H-18102, 3/4"x 1", 3/8" Perforator - 1912429</p>	<p>October 1, 2021</p>	<p>December 15, 2021</p>
<p>TAPS 2.5</p>	<p>T.D. Williamson Tapping and Stopping Procedures Appendix C ShortStopp Spherical 3-Way Tee Correction: Removed 2", ANSI Class 150, Threaded Cap Reinstalled 6", ANSI Class 300, Flanged Top that was mistakenly removed in October 1, 2021 Update</p>	<p>October 1, 2021</p>	<p>December 15, 2021</p>
<p>TAPS 3</p>	<p>Forms and Reference Materials Reference Materials Added: TDW TDXX and TD1XX Drilling Machines Models 6" – 14"</p>	<p>October 1, 2020</p>	<p>December 15, 2021</p>
<p>VALV 3</p>	<p>Approved Valves and Valve Box Accessories 4.0 Plastic (PE) Ball Valves Table 1- Added PE2708 to the Material column. Table 2 – Added PE4710 to the Material column and updated Rating to 125 psig. Table 3 – Update made to Material designation and to some of the valve dimensions. Table 4 - Update made to Material designation and to some of the valve dimensions. 5.0 Steel Ball Valves Table 6 – Corrected Stock Code, 3922604, for 6", Full Port, Flange x Flange, 740 psig valve. Table 7 – Updated some Balon, WxW ball valve dimensions. Table 8 - Updated some Kerotest, WxW ball valve dimensions. Table 10 - Updated some Balon, WxFL ball valve dimensions. Table 11 - Updated a couple Kerotest, WxFL ball valve dimensions. Table 14 - Updated a Kerotest, FLxFL ball valve dimensions. Added Red Text for values that were changed in October Update. 6.0 Kerotest Gate Valves</p>	<p>October 1, 2021</p>	<p>December 1, 2021</p>

	Table 23 – Updated the Number of Turns for 4" Class 300 valve.		
WELD 2.6	Radiographic Testing 5.0 Radiographic Testing Personnel 5.1.1 – Added – NOTE: A 5 year recertification interval may be acceptable, if approved by AIC, for those NDT companies which conduct the additional required certification testing.	October 1, 2020	December 15, 2021
WELD 2.7	Magnetic Particle Testing 5.0 Magnetic Particle Testing Personnel 5.1.1 – Added – NOTE: A 5 year recertification interval may be acceptable, if approved by AIC, for those NDT companies which conduct the additional required certification testing.	October 1, 2020	December 15, 2021
WELD 2.8	Liquid Penetrant Testing 5.0 Liquid Penetrant Testing Personnel 5.1.1 – Added – NOTE: A 5 year recertification interval may be acceptable, if approved by AIC, for those NDT companies which conduct the additional required certification testing.	October 1, 2021	December 15, 2021
WELD 2.9	Ultrasonic Thickness Examination 2.0 Scope Remove Appendices and Appendix A	October 1, 2021	December 15, 2021
WELD 4	Reference Materials All of the SMAW and GMAW welding procedures are being replace with new formatted procedures. These were to be included in the October 1, 2021 electronic O&M but due to conversion issue were not included. They are in the Welding Manuals the welders are being issued	October 1, 2021	December 15, 2021

Rescission

SUMM - Change Summary, October 1, 2021.

UNCONTROLLED IF PRINTED

UNCONTROLLED IF PRINTED

CHANGE SUMMARY

October 1, 2021

Complete Change Summary			
Docu- ment	Change Summary	Previ- ous Docu- ment Dated	Cur- rent Docu- ment Dated
FORW	Gas Operations and Services Contracts: Removed Nick Skertich from the Maximo, ClicMobile, ClickSchedule group.	October 1, 2020	October 1, 2021
ABND 1	Requirements Target Audience – Added Gas Control Operator Qualifications – Added 1371 – System Control Center Operations	April 1, 2021	October 1, 2021
ACIG 1	Requirements 4.0 Sources of Ignition Throughout this section "hazardous environment" replaces "hazardous atmosphere"	October 1, 2020	October 1, 2021
ACIG 2	Work Area Protection Throughout this section "environment" replaces "atmosphere" WIGE 2.1 Hazardous Environment replaces	October 1, 2020	October 1, 2021

UNCONTROLLED IF PRINTED

WWBG
Haz-
ardous
Atmos-
phere
EXCV
2.09
Working
In Haz-
ardous
Environ-
ment re-
places
Working
in Haz-
ardous
Atmos-
phere.
Target
Audi-
ence:
Added
Gas
Control
5.0 Tools
and
Equip-
ment
**5.4 Clar-
ified –
At least
1 fire
extin-
guisher
shall be
on the
jobsite
and up-
wind
from the
work
area.**
Operator
Qualifi-
cations:
Added
1371 –
System
Control
Center
Opera-
tions
Refer-
ence

UNCONTROLLED IF PRINTED

	<p>Documents: Updated EXCV 2.09 & WIGE 2.1</p>		
<p>BORE 0</p>	<p>Table of Contents BORE 2.1 – Added a separate section of each Bore Method and Pipe Installation</p>	<p>October 1, 2020</p>	<p>October 1, 2021</p>
<p>BORE 2.1</p>	<p>Boring Op- erations and Pipe Installation 2.0 Scope – Each Bore Method is a separate Section and Pipe Installation is a Sec- tion. Through- out this section "shall" re- places "must". 4.0 Boring Operations 4.3 Prior to Beginning Operations 4.3.3 Pot holes shall: Item 2. Added – "and that there is sufficient</p>		

**clearance
as stated
in MAIN 1
Paragraph
10.2.1 or
SERV I
Section
8.0 Under-
ground
Clear-
ances.**

7.0 Direc-
tional
Drilling

7.5 –

Added liq-
uid addi-
tives –
Drilling
muds or liq-
uid addi-
tives shall
be used
during
drilling and
back ream-
ing when
soil condi-
tions re-
quire it.

7.13

**NOTE: Re-
vised –
For larger
diameter
pipe such
as 6 inch
and
greater,
pulling
back a se-
ries of pro-
gressively
larger
reamers
may be
needed
prior to
beginning
pullback
opera-
tions.**

9.0 Pipe In-
stallation

9.2 PE
Pipe
9.2.7
Added
means –
Pipe
rollers,
skates or
protective
devices or
means to
prevent
damaging
pipe from
the edges
of the pit or
substruc-
tures dur-
ing pull-in.
**9.2.7
NOTE –
New – Use
of scrap
pipe for
rollers is
accept-
able.**
**9.2.12 –
Revised –
Observe
the bore
head, back
reamer
and lead-
ing end of
pipe as
they pass
through
the pot
holes to
ensure ad-
equate
clearance
between
the pipe
and other
buried fa-
cilities.**
9.3 Steel
Pipe
**9.3.5 – Re-
vised - Ob-
serve the
bore head,**

	<p>back reamer and leading end of pipe as they pass through the pot holes to ensure adequate clearance between the pipe and other buried facilities.</p>		
BORE 2.2	<p>Boring Across or Near Sewer Lines 5.0 Pre-Construction Steps 5.1 – "should" replaces "shall"</p>	December 1, 2020	October 1, 2021
CLAS 1	<p>Requirements 6.0 Class Location Determination 6.3 – Revised – Pipeline Integrity Management staff utilizes software to simulate the sliding mile to determine class location. 11.0 Potential Impact Circle 11.1 Calculations – Corrected the PIR answer 11.2 Calculations – Corrected the AIC's PIR answer with 10% buffer.</p>	December 1, 2020	October 1, 2021
CLAS 2	<p>Annual Class Location and HCA Study 5.0 Action Required for Review of a Class Location Change 5.1.5 – Removed "taking pressure</p>	October 1, 2020	October 1, 2021

UNCONTROLLED IF PRINTED

	gradient into account". 5.1.5 Note - Removed		
CNTS 1	Requirements Throughout this section Meter Specialist replaces Meter Reader 8.0 System Review Responsibilities of Gas Supervisors 8.4 – Added "or e-mail" 10.0 System Review Responsibilities of Gas Superintendents 10.3 - Added "or e-mail"	December 1, 2020	October 1, 2021
CONF 1	Requirements Throughout this section "environment" replaces "atmosphere"	January 1, 2016	October 1, 2021
CONS 1	Requirements Target Audi-	April 1, 2021	October

UNCONTROLLED IF PRINTED

	ence Added - Gas Control Operator Qualifi- cations – Added 1371 System Control Center Opera- tions		1, 2021
CONS 2	Inspec- tor Re- sponsi- bilities Target Audi- ence Added - Gas Control Operator Qualifi- cations – Added 1371 System Control Center Opera- tions	April 1, 2021	Oc- to- ber 1, 2021
CORR 1	Require- ments 13.0 Electrical Isolation 13.3 – "com- bustible environ- ment" replaces "com- bustible atmos- phere"	April 1, 2021	Oc- to- ber 1, 2021
CORR 2.1	Cathod- ic Pro-	April 1, 2021	Oc- to- ber

UNCONTROLLED IF PRINTED

<p>tection Design</p> <p>6.0 Electrical Isolation</p> <p>6.1 Obtaining Electrical Isolation</p> <p>6.1.4 - "combustible environment" replaces "combustible atmosphere"</p> <p>7.0 Insulating Points</p> <p>7.1 NOTE - "combustible environment" replaces "combustible atmosphere"</p> <p>8.0 Insulating Materials</p> <p>8.4 Insulating Unions</p> <p>Table 3 – Removed 1-1/4", 500 psig Union. No longer stocked by AIC.</p> <p>Appendix A Insulation</p>	<p>1, 2021</p>
---	----------------

	<p>Kits for Flanges</p> <p>A-2 – Re-moved 2" and 3" Class 300 Gasket Only for Raised Face Flanges.</p> <p>A-3 – Re-moved 1-1/4" Class 600 Gasket Only for Raised Face Flanges.</p>		
CORR 2.3	<p>Coatings</p> <p>10.0 Approved Paint Specification</p> <p>10.1 Approved Paints</p> <p>10.1.2 - Added NOTE: Shop fabricated farm taps and small regulator stations can be coated with any of the approved paints listed in Appendix J. Application shall be in accordance with manufacturer's specifications and instructions. Refer to CORR 3</p> <p>10.1.3 – Added – and in accordance with</p>	<p>April 1, 2021</p>	<p>October 1, 2021</p>

	<p>manufacturer's instructions</p> <p>10.1.3 – New Item 5. – Gas storage field piping.</p> <p>I-5 Moisture Cured Wrap</p> <p>Item 5. Moisture Cured Wrap (MCW) Coverage Table</p> <p>Added coverage for 2", 3" and 30" pipe.</p> <p>Appendix J Approved Paints for Pipeline Facility Coating</p> <p>Updated the table to show Tnemec paints are acceptable for coating farm taps and small regulator stations.</p> <p>Appendix K – Inspection Voltages</p> <p>Added voltages for mil thicknesses 20 through 32 and 50 through 60.</p>		
<p>CORR 2.8</p>	<p>Cathodic Protection Testing</p> <p>Appendix A Cathodic Test Stations</p> <p>A-9 AC Stray Current Test Station – Add stock code 22 42 220 for Stelth 7 Reference Cell.</p> <p>Appendix B Test Lead Wire Attachment</p>	<p>April 1, 2021</p>	<p>October 1, 2021</p>

	<p>2. Cadweld Thermite Welding Process A Installation (1) – "environment" replaces "atmosphere"</p> <p>3. CadWeld Plus Process A. Installation (1) - "environment" replaces "atmosphere"</p> <p>5. Pin Brazing D. Pin Brazing (1) - "environment" replaces "atmosphere"</p>		
CORR 2.11	<p>Records Appendix A – Cathodic Protection Review Responsibility Table</p> <p>Updated Technician/ Specialists for: Decatur Champaign, Danville, Hoopeston Mt. Vernon, Sparta, Centralia, and eastern Belleville</p>	April 1, 2021	October 1, 2021
CORR 3	Forms and Reference	April 1, 2021	October

UNCONTROLLED IF PRINTED

	<p>Materials</p> <p>Updated Denso Protal 7200 Instructions – removed requirement for Denso Representative to train applicators.</p> <p>Updated Denso Protal 7300 Instructions – re-arranged sheets in the instructions.</p>		1, 2021
DAMG 1	<p>Requirements</p> <p>5.0 Illinois One-Call System – JULIE</p> <p>5.1 General Notes</p> <p>5.1.4 – Back flagging best practice:</p> <p>Move the following language from MAIN 1 and</p>	October 1, 2020	October 1, 2021

UNCONTROLLED IF PRINTED

	<p>SERV 1 to DAMG 1:</p> <p>1. Place "Yellow" locating flags, yellow headed stakes and/or yellow marking paint over the new facilities.</p> <p>2. Place enough flags/ stakes to ensure the facilities are clearly identified as to route and location.</p>		
EMER 1	<p>Re-quire-ments</p> <p>4.0 General</p> <p>4.3 AIC Emergency Plan addresses how AIC OQ personnel evaluate</p> <p>.....</p> <p>4.3.7 – New – Accidental release of gas from an</p>	April 1, 2021	June 3, 2021

UNCONTROLLED IF PRINTED

	<p>under-ground natural gas storage facility.</p> <p>This change was effective June 3rd to clear IDNR storage field audit findings. Applicable to only Gas Storage Field personnel.</p>		
<p>EMER 2.4</p>	<p>General</p> <p>Target Audience – Added Gas Control Operator Qualifications – Added 1371 System Control Center Operations</p>	<p>April 1, 2021</p>	<p>October 1, 2021</p>
<p>EMER 2.4.3</p>	<p>Major Leak or Line Break</p> <p>1.0 Dispatched to Major Leak or Line Break</p> <p>1.5.1. – WIGE</p>	<p>October 1, 2020</p>	<p>October 1, 2021</p>

UNCONTROLLED IF PRINTED

	2.1 re-places WWBG 2.1		
EMER 2.4.4	Gas in Sewer 1.0 Dispatched to Gas in Sewer 1.3 – "environment" replaces "atmosphere"	October 1, 2020	October 1, 2021
EMER 2.5	Natural Disasters or Civil Disobedience Target Audience – Added Gas Control Operator Qualifications – Added 1371 System Control Center Operations	October 1, 2020	October 1, 2021
EMER 2.6	Emergency Personnel and Materials 6.0 Centralized Emergency Gas Material 6.1 The Gas Standards Engineer shall: 6.1.3 – Inventory emergency gas materials at centralized locations 1 time each	October 1, 2020	October 1, 2021

UNCONTROLLED IF PRINTED

	calendar year.		
EMER 2.9	<p>CNG Trailers</p> <p>5.0 CNG Trailer by Location and Capacity</p> <p>Table 1 – Rick Dougherty replaces Kelly Coppernoll as contact for Kewanee and Peoria.</p> <p>8.0 CNG Filling Stations</p> <p>Table 3 – Added Edwards, IL location</p>	April 1, 2021	October 1, 2021
EMER 2.10	<p>Gas Controls</p> <p>1.0 Purpose - Expanded - This procedure provides information about Ameren Illinois (AIC) Gas Control's response when there has been a loss of communication with or an alarm from a</p>	October 1, 2020	October 1, 2021

UNCONTROLLED IF PRINTED

**remotely
monitored or
controlled
device.**

Throughout this section "and controls" was added where there was a reference to Gas Control remotely monitors.

4.0 General

4.5 – Revised - Gas Control remotely monitors and controls critical points of AIC's transmission and distribution gas systems. Required communications and coordination between operations personnel and Gas Control is included throughout the Ameren

UNCONTROLLED IF PRINTED

**Illinois
Gas
O&M
Plan.**

5.0 Loss of
Communi-
cations

5.2 If com-
munications
is lost to
these de-
vices

**5.2.2 –
"may be
dis-
patched"
replaces
"will go"**

**5.2.3 –"
When im-
mediate re-
pairs can-
not be
made" re-
places "If a
repair can-
not be
made".**

**5.3 – New –
When SCA-
DA indi-
cates a
monitoring,
control or
communi-
cations
problem,
GTS per-
sonnel may
be dis-
patched to
the site.**

**5.4 – Re-
vised –
When the
loss is de-
termined to
be wide
spread or
the condi-
tions indi-
cate a long
duration:**

5.4.1 – "may initiate" replaces "will initiate"

6.0 Alarm Management

6.2 – Revised - When Gas Control personnel have determined the alarm requires field investigation, the appropriate GTS personnel or GTS Supervisor are contacted.

6.2.1 – Revised - GTS personnel will go to the site to investigate the cause of the alarm and notify Gas Control upon their arrival at the site.

6.2.3 – Revised - If the alarm(s) were due to a significant abnormal operation that could have had an impact on adjacent systems, Gas

	<p>Control will monitor and review critical facilities in the adjacent systems to ensure the integrity of EACH associated gas system has not been compromised and their MEP has not been exceeded.</p> <p>Operator Qualifications – Added</p> <p>1371 – System Control Center Operations</p> <p>1381 – Local Facility Remote Control Operation</p>		
EXCV 0	<p>Table of Contents</p> <p>EXCV 2.09 – Working in Hazardous Environment</p>	October 15, 2018	October 1, 2021
EXCV 1	<p>Requirements</p> <p>Throughout this section, "hazardous environment" replaces "hazardous atmosphere".</p>	January 1, 2014	October 1, 2021
EXCV 2.01	Prior to Excavation	December-	October-

UNCONTROLLED IF PRINTED

	<p>2. Job Preparation</p> <p>2. E. Revised – A fire extinguisher shall be on the jobsite when excavating around a gas line.</p>	ber 1, 2020	ber 1, 2021
EXCV 2.07	<p>Aluminum Hydraulic Shoring Protective System</p> <p>2. Hydraulic Shoring</p> <p>2. W. - "hazardous environment" replaces "hazardous atmosphere".</p>	January 1, 2014	October 1, 2021
EXCV 2.08	<p>Trench Box Protective System</p> <p>2. Trench Box Protective System</p> <p>2. O. - "hazardous environment" replaces "hazardous atmosphere".</p>	January 1, 2014	October 1, 2021
EXCV 2.09	<p>Working in Hazardous Environment</p> <p>Throughout this section "hazardous environment" replaces "hazardous atmosphere" and WIGE 2.1 and WIGE 2.2</p>	December 1, 2020	October 1, 2021

UNCONTROLLED IF PRINTED

	replaces WWBG 2.1 and WWBG 2.2 3. Entering Excavation 3. F. Revised – A properly sized dry chemical (A, B, C) fire extinguisher shall be at the location of the work. See WIGE 2.1 Paragraph 4.2.2		
--	---	--	--

GLOS	Glos- sary Added: Fire Ex- tin- guisher Loca- tions: On the Jobsite – fire extin- guisher located on truck in the general vicinity of the work being per- formed. At loca- tion of the work – fire ex- tin- guisher is off the	De- cem- ber 1, 2020	Oc- to- ber 1, 2021
-------------	---	----------------------	---------------------

UNCONTROLLED IF PRINTED

<p>truck and located near where the work is being performed.</p> <p>Manned – qualified individual is actively manning the fire extinguisher near where the work is being performed.</p> <p>Revised:</p> <p>Lower Explosive Limit (LEL) – gas-in-air replaces gas atmosphere.</p> <p>Upper Explosive Limit (UEL) - gas-in-air replaces gas atmosphere.</p>		
---	--	--

<p>INCD 1</p>	<p>Require- ments</p> <p>4.0 Gen- eral</p> <p>4.2 AIC's several reporting time con- straints</p> <p>4.2.3 Po- tential re- portable incident:</p> <p>1 a. & 1 b. – Re- moved duplicate verbiage on Po- tential Incident.</p> <p>5.0 Nat- ural Gas Incident</p> <p>5.1 A natural gas inci- dent in- volves</p> <p>5.1.3 – Correc- tion made to the esti- mated property damage value to \$50,000 for re- porting to ICC or IDNR.</p> <p>5.1.3. NOTE – New – Ex- plains why ICC's</p>	<p>April 1, 2021</p>	<p>Oc- to- ber 1, 2021</p>
--------------------------	---	------------------------------	--

UNCONTROLLED IF PRINTED

estimated property damage value if \$50,000.

6.0 Potential Significant Event

6.1 A Potential Significant Event may include:

6.1.3 – Revised – A natural gas fueled fire with estimated property damage exceeding \$25,000.

Appendix A: Gas Compliance Reporting

3. Estimated property damage excluding cost of gas lost:

3 a. – Correction - \$25,000 or more for reporting to ICC

UNCONTROLLED IF PRINTED

or PHM-SA.

3 b. – Added "or more"

7 Natural gas fueled fire with estimated property damage:

7 a. – Correction - \$25,000 or more replaces \$60,000

7 b. - Added "or more"

Appendix B: State and Federal Reporting

3. Estimated property damage, excluding cost of gas lost:

Correction - \$50,000 for reporting to ICC and ID-NR.

Note (2) – Added – "PHM-SA re-reporting"

	<p>Appendix C: AIC, State, and Federal Reporting Contacts</p> <p>Table 2: Corrected Matt Smith, ICC, Mobile Phone Number.</p>		
<p>INVE 2.1</p>	<p>Investigations</p> <p>Target Audience – Added Gas Control Operator Qualifications – Added 1371 – System Control Center Operations 1381 – Local Facility Remote Control Operation</p>	<p>October 1, 2020</p>	<p>October 1, 2021</p>
<p>LEAK 1</p>	<p>Requirements</p> <p>4.0 General 4.3 – New – Section describes the actions to</p>	<p>April 1, 2021</p>	<p>October 1, 2021</p>

UNCONTROLLED IF PRINTED

be taken if the initial investigation determines AIC is not the licensed gas distribution company for the area and does not have gas facilities in the vicinity.

7.0 Distribution Leak Surveys

7.1.4 – New – Cathodically un-protected distribution lines at least once every 3 calendar years not to exceed 39 months.

7.1.4 NOTE – Re-moved since it incorrectly stated that AIC

UNCONTROLLED IF PRINTED

	<p>didn't have cathodically un-protected lines.</p> <p>14.0 Records – Added Code references</p> <p>Compliance Requirements – Added Code references</p>		
<p>LEAK 2.1</p>	<p>Indoor Leak Investigation</p> <p>5.2 – "gas-free environment" replace "gas-free atmosphere".</p> <p>7.0 Customer Home</p> <p>7.2 – Correction – gas-in-air reading at entrance</p> <p>7.6 – New – Once an inside leak investigation is complete, check all</p>	<p>October 1, 2020</p>	<p>October 1, 2021</p>

UNCONTROLLED IF PRINTED

	<p>above grade piping and meter set for leaks to ensure there is no leakage on AIC's above grade facilities.</p>		
<p>Leak 2.2</p>	<p>Outdoor Leak Investigation Throughout this section "environment" replaces "atmosphere" 5.0 Upon Arrival 5.2 - "gas-free environment" replace "gas-free atmosphere".</p>	<p>October 1, 2020</p>	<p>October 1, 2021</p>
<p>LEAK 2.3</p>	<p>Leak Investigation Form 6.0 Outdoor Leak Investigation Record 6.1.10 Item 2 – "environment" replaces</p>	<p>October 1, 2020</p>	<p>October 1, 2021</p>

UNCONTROLLED IF PRINTED

	"atmosphere"		
LEAK 2.4	<p>Leak Surveys</p> <p>5.0 Distribution Mains and Services</p> <p>5.2.1 Item 1 – Added NOTE – Atmospheric corrosion monitoring survey as required under §192.481 and CORR 1 Paragraph 15.3.2 is included in the distribution mains and services leak surveys</p> <p>5.2.1 Item 2. NOTE - Removed since it incorrectly stated that AIC didn't have cathodically unprotectd lines.</p>	<p>October 1, 2020</p>	<p>October 1, 2021</p>

	<p>9.0 Un-protected Steel Lines</p> <p>NOTE – Removed since it incorrectly stated that AIC didn't have cathodically un-protected lines.</p>		
<p>LEAK 2.8</p>	<p>Survey Maps and Records</p> <p>5.0 Maps and Records</p> <p>Added Code reference</p> <p>5.6.1 – New - If atmospheric corrosion monitoring is performed in conjunction with the distribution leak surveys, records shall maintained in Maximo of at least the two most recent at-</p>	<p>October 1, 2020</p>	<p>October 1, 2021</p>

UNCONTROLLED IF PRINTED

	mos- pheric corro- sion in- spec- tions.		
LEAK 3	Forms and Ref- erence Materi- als Updated: iTrans 2 User Manual Revision 7.0 MBW Vapor Extrac- tion Unit Operator Safety and Ser- vice Manual	April 1, 2021	Oc- to- ber 1, 2021
MAIN 1	Require- ments 17.0 Back- Flagging 17.1 – Added refer- ence link to DAMG 1. Moved the previ- ous lan- guage on back- flagging methods to DAMG 1.	Oc- to- ber 1, 2020	Oc- to- ber 1, 2021
MAIN 2.1	Joint Trench Install- ation 5.0 Gas/ Electric	Oc- to- ber 1, 2020	Oc- to- ber 1, 2021

UNCONTROLLED IF PRINTED

	<p>Joint Trench Installation</p> <p>5.1 installation Requirements</p> <p>5.1.8 – Revised to 12 inch clearance from all other facilities. Removed the 6 inch clearance from electric service.</p>		
MAIN 2.2	<p>Lowering or Realignment of Pipe</p> <p>1.0 Purpose</p> <p>Remove reference to Code sections since they are not applicable.</p>	<p>October 1, 2020</p>	<p>October 1, 2021</p>
MAIN 3.1	<p>Lateral Tap</p> <p>5.0 Steel Tees to PE Pipe</p> <p>5.2 – Added Curb – Mueller Curb Valve</p>	<p>April 1, 2021</p>	<p>October 1, 2021</p>

UNCONTROLLED IF PRINTED

Tee to PE Pipe		
6.0 Steel Tees to Steel Pipe		
6.2 - Added Curb – Mueller Curb Valve Tee		
Appendix B – Steel Tees to PE Pipe.		
B-2 – Changed to Mueller Curb Valve Tee:		
B-2.1.1 – Revised – The Mueller Valve Tee, 19 33 562, may be substituted for the curb valve tee.		
Figure 6 – Mueller Curb Valve Tee		
Table 9 & 10– Item 3 - Updated description – Tee, Steel, Curb Valve, 2", 1440 psig, with		

UNCONTROLLED IF PRINTED

2" x 2" Square Head Table 9 & 10 – Item 5 - Updated Stock Code for the 2" Curb Box. B-3 Mueller Bottom Out Tee Table 11 & 12– Item 3 – Changed rating on 2" Line Stopper to 250 lb. Table 11 & 12 – Item 4 – Updated Stock Code for 6" Inline Tee. Appendix C Steel to Steel Tees C-2 – Title change – Mueller Curb Valve Tee C-2.1.3 – Updated – Mueller Valve Tee may be substituted for curb valve tee.		
--	--	--

UNCONTROLLED IF PRINTED

	<p>Table 16 – Updated Stock Code for 2" Curb Box and Updated description Tee, Steel, Curb Valve, 2", 1440 psig, with 2" x 2" Square Head.</p> <p>C-3 Mueller Bottom Out Tee</p> <p>Table 17 – Item 3 - Changed rating on 2" Line</p> <p>Table 17 – Item 3 - Updated Stock Code for 4" and 6" Inline Tee.</p>		
MAIN 3.2	<p>End of Main Extension</p> <p>Appendix A – Main Extension – PE Pipe A-3 PE Pipe, Decreasing Size</p> <p>Table 6 – Item 4 – Updated Stock Code for 4" x 6"</p>	<p>April 1, 2021</p>	<p>October 1, 2021</p>

UNCONTROLLED IF PRINTED

PE3408/
PE4710
Reducer
Appendix
C – Steel
to Steel
Pipe
C-2 Steel
to Steel
Pipe in-
creasing
Size
Table 20
– Item 4
– Updat-
ed Stock
Code for
2" x 4"
and 4" x
6" Weld
Reducer.
C-3 Steel
to Steel
Pipe de-
creasing
Size
Table 21
– Item 4
– Updat-
ed Code
for 3" x
2" and 4"
x 2" Weld
Reducer.
C-5 TDW
Stopper
– Steel to
Steel
Pipe In-
creasing
Size.
Table 23
– Item 4 -
Updated
Stock
Code for
2" x 4"
and 4" x
6" Weld
Reducer.
C-6 TDW
Stopper
– Steel to

UNCONTROLLED IF PRINTED

	<p>Steel Pipe Decreasing Size.</p> <p>Table 24 – Item 4 – Updated Stock Code for 3" x 2', 4' x 2", 6" x 4" Weld Reducer.</p>		
METR 1	<p>Requirements</p> <p>6.0 Meter Location</p> <p>6.3 Unacceptable Meter Locations</p> <p>6.3.10 Where the service regulator vent is:</p> <p>4. – New – If the requirements above cannot be reasonably met, consult with Gas Engineering for installation of an approved slam-shut regulator.</p> <p>11.0 Removed Meters</p>	<p>April 1, 2021</p>	<p>October 1, 2021</p>

	11.3 – Added – and re-moved from the premise		
METR 2.4	Meter In-spection and Testing – GTS 7.0 Ultra-sonic Meter Testing 7.3 Transmitter In-spection 7.3.1 – Changed verification of all transmitters to at least every 6 months.	October 1, 2020	October 1, 2021
METR 2.8	Pressure Factor Metering 6.0 Pressure Factor Metering 6.4.1 – Revised – Adjust the regulator to the selected metering pressure with gas flowing. 10.0 Other Related Actions	April 1, 2021	October 1, 2021

10.1 – Revised – The regulator that is used in conjunction with fixed factor billing shall be secured if it is discovered that the pressure setting has been tampering with. The regulator spring cap can be secured by means of installing a seal wire, where possible, or by other means. Twist wire seals are available through the Gas Meter Shop or MDF (Stock Code 62 55 093). Electric depart-

	ment wire seals are also accept- able.		
METR 2.10	<p>Gas Meter Data Sheet</p> <p>Target Audience</p> <p>Supervisor Illinois Meter Shops replaces Gas Meter Supervisor</p> <p>4.0 Gas Meter Data Sheet</p> <p>4.2.4 – Change – Meter index is changed on any meter with elevated pressure.</p> <p>5.0 Completion Instructions</p> <p>5.2 – New – While at the customer's premise, applicable pictures will be taken too attached to the GMDS including:</p> <p>5.2.1 Gas meter serial number badge.</p> <p>5.2.2 Gas meter index.</p> <p>5.2.3 Pressure</p>	April 1, 2021	Oc- to- ber 1, 2021

UNCONTROLLED IF PRINTED

gauge reading.

5.2.4 Corrector serial number badge.

5.2.5 Any other appropriate pictures.

6.0 Report Distribution

6.1 – Revised – After supervisor approval, a copy of each completed GMDS will be forwarded electronically to the appropriate co-workers/department. An email alert will be sent from ILGMD-SALERT. The GMDS Teams App will automatically route the completed GMDS to the appropriate co-workers/department.

7.0 Gas Metering Review WFM

7.1 Table 1 – Added –

	<p>Pressure Change under Pressure Factor > 1 column for an Exchange.</p> <p>7.2 – Supervisor Illinois Meter Shops replaces Gas Metering Supervisor.</p> <p>7.3 – Regional replaces Division</p> <p>7.4.2 - Supervisor Illinois Meter Shops replaces Gas Metering Supervisor.</p> <p>Appendix A GMDS Completion Instructions</p> <p>A-3.5 Remarks and Review</p> <p>91. – Added – Also, attach all of the required pictures to the electronic GMDS for the work performed.</p>		
<p>METR 3.1</p>	<p>Meter Sizing Appendix A – Approved Meters for</p>	<p>October 1, 2020</p>	<p>October 1, 2021</p>

	<p>New Installations</p> <p>A-1 – Removed capacities for AC630 at metering pressures of 20 & 25 psig.</p> <p>Correctors cannot be installed on AC630 and no fixed factor billing above 15 psig.</p> <p>Appendix B Capacities for Existing Meter Installations</p> <p>B-1 – Removed capacities for AL425 & AC630 at metering pressures of 20 & 25 psig.</p> <p>B-2 - Removed capacities for Sprague #3, #4, #5 at metering pressures of 20 & 25 psig.</p>		
<p>METR 3.2</p>	<p>Regulator Sizing</p> <p>4.0 General</p> <p>4.3 – New – Contact gas engi-</p>	<p>April 1, 2021</p>	<p>October 1, 2021</p>

UNCONTROLLED IF PRINTED

**neering for
slam-shut
regulator
selection
when a
clearance
issue is
identified
between
an ignition
source or
building
vent and
the exist-
ing gas
service
regulator
relief vent
that can't
be relocat-
ed due to
physical
limitation
at the
premise or
financial
hardship.**

Appendix A
– Regula-
tors at New
Installations
at 7" w.c.
Delivery

Updated
some ca-
pacities for
Itron B42R
and Ameri-
can 1813C
Added: 1" x
1" B42R/
1813C, 1/8"
x 3/16" ori-
fice

Corrected
Stock Code
on 1" x 1"
B42R/
1813C, 1/4"
orifice.

Typo Cor-
rection for
2" Fisher

UNCONTROLLED IF PRINTED

CS806-IQ
at 20 psig
Added a
column for
125 psig
Distribution
Pressure
and en-
tered ca-
pacities for
the 3/4"x1"
B42R/
1813C with
1/8"x3/16"
orifice and
1"x1"
B42R/
1813C with
3/16" ori-
fice.
Appendix A
Note (1) –
Added –
with 1% ab-
solute
droop.
Appendix B
– Regula-
tors at 2
psig Deliv-
ery
Updated
capacities
for Itron
1"x1" B42R
with 3/16"
orifice.
Added a
column for
125 psig
Distribution
Pressure
Updated
capacities
for CL31N
and added
a note (10)
Appendix B
Note (1) –
Added –
with 1% ab-
solute
droop.

UNCONTROLLED IF PRINTED

**New Note
(10) – Itron
CL31N
with 1"
outlet pip-
ing will
limit ca-
pacity to
3,000
SCFH.**

Appendix C
– Regula-
tors at 5
psig Deliv-
ery

Updated
capacities
for Itron
CL31N with
Note (4)

Added ca-
pacities for
80, 100 and
125 psig in-
let pres-
sure.

Appendix C
Note (1) –
Added -
with 1% ab-
solute
droop.

**New Note
(4) - Itron
CL31N
with 1"
outlet pip-
ing will
limit ca-
pacity to
3,000
SCFH.**

Appendix
D– Regula-
tors at 10
psig Deliv-
ery

Updated
capacities
for Itron
CL31N and
added note
(5)

	<p>Updated capacities for 2" Fisher 299H at 25 psig.</p> <p>Added capacities for 80, 100 and 125 psig inlet pressure.</p> <p>Appendix D Note (1) - Added - with 1% absolute droop.</p> <p>New Note (5) - Itron CL31N with 1" outlet piping will limit capacity to 3,000 SCFH.</p> <p>Appendix E – Alternative Regulators</p> <p>Itron replaces Actaris.</p> <p>Appendices E-1 – E-4</p> <p>Added capacities for 80, 100 and 125 psig inlet pressure.</p> <p>Note (1) - Added - with 1% absolute droop.</p>		
<p>METR 3.3</p>	<p>Diaphragm Meter Sets Revised throughout this</p>	<p>April 1, 2021</p>	<p>October 1, 2021</p>

UNCONTROLLED IF PRINTED

**document
- Customer
piping will
be con-
nected to
the 1"
FNPT Out-
let.**

**Item 4 –
Mueller
Brisco By-
pass Plug
Valve add
to the fol-
lowing:**

Appendix A
– 175/250
Meter, 7"
w.c. Deliv-
ery, 1-60
psig Inlet.

Appendix B
- 175/250
Meter, 2
psig, Deliv-
ery, 5-60
psig Inlet.

Appendix C
- 175/250
Meter, 7"
w.c. Deliv-
ery, 61-125
psig Inlet.

Appendix D
- 175/250
Meter, 2
psig, Deliv-
ery, 61-125
psig Inlet.

Appendix C
– 175/250
Meter, 7"
w.c. Deliv-
ery

Increased
inlet pres-
sure range
– 61 – 125
psig.

Appendix D
- 175/250
Meter, 2

	<p>psig Delivery</p> <p>Increased inlet pressure range – 61 – 125 psig.</p> <p>Appendix K – Multiple Meter Installation</p> <p>K-1 & K-2 – Item 4 – Added the Bypass Ball Valve and the Mueller Brisco Bypass Valve</p>		
METR 3.4	<p>Compact and Rotary Meter Sets</p> <p>Appendix A through H – Corrected the 2" Adjustable Pipe Support Length to 22"</p>	<p>October 1, 2020</p>	<p>October 1, 2021</p>
METR 4	<p>Forms and Reference Materials</p> <p>Forms:</p> <p>Updated Electronic Corrector Inspection Form</p> <p>References:</p> <p>Updated:</p> <p>Fisher CS400, CS800, 299H Manuals</p>	<p>October 1, 2020</p>	<p>October 1, 2021</p>

	Itron B31, B34, B42, CL31, CL34 Manuals		
ODOR 1	Requirements Target Audience – Added Gas Control Operator Qualifications – Added 1371 System Control Center Operations	April 1, 2021	October 1, 2021
ODOR 2.2	Odorization Operations and Transportation Operator Qualifications – Added 1371 System Control Center Operations	April 1, 2021	October 1, 2021
ODOR 2.3	Emergency Response 6.1.1 WIGE 2.2 replaces WWBG 2.2	October 1, 2020	October 1, 2021
OQAL 2.02	Covered Tasks AOC's Updated: Task 0131 – Insert and Remove Coupons/ Probes for Internal Corrosion - Added Monitoring	April 1, 2021	October 1, 2021

UNCONTROLLED IF PRINTED

**Task 0701
– Joining
Pipe – Bot-
tom-Out
Compres-
sion Cou-
plings –
Updated
Task Spe-
cific AOC's**

Task Spe-
cific AOC's

– haz-
ardous en-
vironment
replaces
hazardous
atmos-
phere, in
the follow-
ing Tasks:

Task 0051
– Installa-
tion of
Exothermic
Electrical
Connec-
tions

Task 1241
– Outside
Gas Leak
Investiga-
tion

Task 1361
– Station
Emergency
Shutdown
System –
Inspection,
Testing and
Corrective
Mainte-
nance,

Added:

**Task 1681
– Inspect,
Test, and
Maintain
Liquid
Knockout
(Dehydra-
tion) Sys-
tem**

	<p>Task 1691 - Inspect, Test, and Maintain Glycol Dehydration System</p> <p>Task 1701 - Inspect, Test, and Maintain Mole Sieve Dehydration System</p> <p>Task 1285 – Inspect Water Crossing</p> <p>Task 1371 – Operate Gas Pipeline – System Control Center Operations</p> <p>Task 1020 – Perform Electrical inspection of Pipe Coating (Holiday Detection or Jeeping)</p>		
OQAL 4	<p>Forms and Reference Materials</p> <p>Updated Ameren Illinois Contractor Hiring Checklist contact for Drug testing program.</p>	June 30, 2011	October 1, 2021
	PCBH Section – Reformatted		

	to the October 2020 O&M Template.		
PCBH 0	Table of Contents	New	October 1, 2021
PCBH 1	Requirements	New	October 1, 2021
PCBH 2.0	Sampling Liquids from Gas Piping Systems	New	October 1, 2021
PCBH 2.1	Positive PCB Detection	New	October 1, 2021
PCBH 2.2	Staging Area and Disposal Area Protocol	New	October 1, 2021
PCBH 2.3	Liquid Release Protocol	New	October 1, 2021
PCBH 2.4	Wipe and Soil Sampling	New	October 1, 2021
PCBH 3	Forms and Reference Materials	New	October 1, 2021
PIGG 2.1	Pigging Operations Target Audience – Added Gas Control	October 1, 2020	October 1, 2021

<p>PMRK 2</p>	<p>Pipeline Facility Markers Appendix A-2 Car- sonsite Pipeline Marker Removed the 62" pipeline marker</p>	<p>April 1, 2021</p>	<p>Oc- to- ber 1, 2021</p>
<p>POLY 2.1</p>	<p>Design Pressure 4.0 Design Pressure 4.1 – NOTE: De- sign Pres- sure for CTS pipe uses: P = 2S (t/ (D-t) (DF) formula since CTS pipe does not have a published SDR value. 4.2 – New – AIC used Design Factor (DF) of 0.32 for all PE pipe in- stallation prior to October 1, 2021. 4.3 – New - PE4710 pipe instal- lation on or after October 1, 2021, DF = 0.40 can be used as long as:</p>	<p>April 1, 2021</p>	<p>Oc- to- ber 1, 2021</p>

4.3.1 – Design Pressure does not exceed 125 psig.

4.3.2 – Pipe designation is PE4710.

4.3.3 – Nominal pipe size is 24 inches or less.

4.3.4 – Pipe was manufactured on or after January 1, 2019.

4.3.5 – AIC's PE4710 pipe meets or exceeds minimum wall thickness required for DF= 0.40.

CAUTION: MAOP of a PE pipe segment or system must be established prior to placing the segment or system into service, PE pipe system's MAOP cannot be updated without taking the system or

<p>segment out of service and then testing.</p> <p>6.0 MAOP Limitations for PE Pipe</p> <p>6.2 – Revised – The MAOP for all PE4710 mains and service lines installed prior to October 1, 2021 shall be limited to 100 psig.</p> <p>6.3 – New – The MAOP for PE4710 main and service lines installed on or after October 1, 2021 shall be limited to a maximum of 125 psig.</p> <p>Appendix A – Stock Coded PE Pipe</p> <p>Appendix A-2 – PE4710 Pipe</p> <p>Note 1. – Added 1/2" CTS which also requires a SDR 7.0 riser.</p>		
---	--	--

<p>POLY 2.2</p>	<p>Squeeze Off 6.4 – Updated WIGE 2.1 – Hazardous Environment</p>	<p>April 1, 2021</p>	<p>October 1, 2021</p>
<p>POLY 2.3</p>	<p>Installation Requirements 10.0 Weak Link 10.1 – Added – trenchless excavations 10.1.4 – Revised – Pulling pipe in by hand through the ground or casing. 10.2 Installation options to protect pipe.... 10.2.1 PE pipe sizes 1" CTS or smaller 3. Revised – Weak link is required when pulling pipe by hand through the ground or casing. 10.4 Condux Swivels Corrected Part No of replacement pin of 1"CTS PE2708 pipe.</p>	<p>April 1, 2021</p>	<p>October 1, 2021</p>
<p>POLY 2.4</p>	<p>Butt Fusion Appendix A-4 – End Caps – Removed the</p>	<p>April 1, 2021</p>	<p>October 1, 2021</p>

UNCONTROLLED IF PRINTED

	<p>1/2" & 1" CTS End Caps.</p> <p>6" PE3408 End Cap is being set-up at MDF</p> <p>Appendix A-5 – Purge Caps = Updated description:</p> <p>PE2406 Purge Cap is 1"CTS x 12" Long</p> <p>PE3408 Purge Cap is 1/2" CTS x 24" Long</p>		
POLY 2.5	<p>Electrofusion</p> <p>5.1 – hazardous environment replaces hazardous atmosphere</p>	<p>April 1, 2021</p>	<p>October 1, 2021</p>
POLY 2.6	<p>Mechanical Joining</p> <p>5.0 Stab Fittings</p> <p>5.1.3 – Revised – A 1" electrofusion coupling is required to connect 1" CTS PE4710 pipe to the service riser pigtail on 1" PE service lines.</p> <p>6.0 – Perfection replaces Honeywell in the chart.</p>	<p>December 1, 2020</p>	<p>October 1, 2021</p>
POLY 3.1	<p>Transition Fittings and Protective Sleeves</p>	<p>April 1, 2021</p>	<p>October 1, 2021</p>

UNCONTROLLED IF PRINTED

	<p>Appendix B – Removed the 18" protective sleeve for 1.875" ID pipe.</p> <p>Added "solid" – protective sleeve is to be installed as one solid piece and not split in half.</p>		
PRES 2.1	<p>Potential Over Pressurization</p> <p>Target Audience – Added Gas Control 6.0 Low Pressure Systems – Removed Belleville's low pressure system. Peoria Glen Brook Apartments is the only remaining low pressure system.</p>	October 1, 2020	October 1, 2021
PRES 2.3	<p>ERX Alarm Change Request</p> <p>2.0 Scope</p> <p>Appendix A – Gas SCADA Alarm Limit Change Request Form Throughout document: Gas SCADA Alarm Limit Change Request Form replaces ERX Alarm</p>	October 1, 2020	October 1, 2021

	<p>Change Request Form</p> <p>4.0 ERX Alarm Change Request</p> <p>4.2 Alarm Change Request</p> <p>4.2.2 – Updated – The Gas SCADA Alarm Limit Change Request form will handle one ERX.</p> <p>Operator Qualifications – Added:</p> <p>1371 – System Control Center Operations</p> <p>1381 – Local Facility Remote Control Operations</p> <p>Appendix A – Copy of new Gas SCADA Alarm Limit Change Request Form.</p>		
PRES 3	<p>Forms and Reference Materials</p> <p>Forms - Update</p> <p>Gas SCADA Alarm Limit Change Request Form</p>	October 1, 2020	October 1, 2021
PTST 0	<p>Table of Contents</p> <p>PTST 1.1 – Updated Appendix B – Design MAOP 125 psig or less.</p>	October 1, 2020	October 1, 2020

	<p>PTST 2.3 Hydrostatic Pressure Testing</p> <p>Section 7.0 – Changed to – Prior to Hydrostatic Testing</p> <p>PTST 2.4 Nitrogen Pressure Testing</p> <p>Removed Section 8.0 Tube Trailer Requirements</p> <p>Added:</p> <p>PTST 2.6 – Welded Fabricated Units and Pressure Vessels</p>		
PTST 1	<p>Requirements</p> <p>6.0 Roles and Responsibilities</p> <p>6.2 DDC & PDC</p> <p>6.2.2 – Revised – All PE mains with Design MAOP 125 psig or less</p> <p>6.2.3 – Revised – All PE and steel service lines with Design MAOP 125 psig or less.</p> <p>8.0 Test Recording Methods</p> <p>8.1.2 – Correction – Pressure recording devices are required for</p>	<p>April 1, 2021</p>	<p>October 1, 2021</p>

UNCONTROLLED IF PRINTED

leak and strength test on lines with Design MAOP of 20% SMYS or greater.

10.0 Testing

10.3 – PTST

1.1

10.3.2 – Revised – Table B: Plastic Main – All PE Pipe Sizes Thru 12": with Design MAOP 125 psig or Less.

10.5 – Added – Refer to Subsection 10.6 for PE4710 testing and meter valve limitations.

10.6 – New - PE4710 mains and service lines with Design MAOP of 125 psig shall be tested separately, due to meter valve limitations, unless approved by the gas engineer.

10.6.1 - Meter valves rated for 175 psig shall not be exposed to a pressure of 200 psig or higher for more than 2 hours. Ex-

ceeding 200 psig for longer periods may cause damage to the valve.

1. The minimum test pressure for a MAOP of 125 psig is 188.0 psig.

2. Testing the PE4710 service line separately should limit the test duration to less than 2 hours and allow the pressure on the service line to be relieved or lowered to below 200 psig following completion of the pressure test.

3. The meter valve pressure limitations stated above applies to all service lines, PE2708, PE4710 and steel.

13.0 Components

13.1 – Removed "after installation"

13.1.3 – New – Components shall

be tested for leaks using leak detection fluids, leak detection instrument or via gauge test.

1. Gauge test shall be held for a minimum of 10 minutes.

2. Leak detection fluids or leak detection instruments have no minimum duration.

13.1.4 – New – Tapping and stopping components shall be tested for leaks PRIOR to tapping.

13.1.5 – Revised – A component (cap, valve, elbow) installed within an existing pipeline: Connection shall be tested for leaks at operating pressure of the pipeline using leak detection fluid or leak detection instrument.

13.1.6 —New – Component with a nominal diameter of

less than 2" shall be, at a minimum, tested for leaks at operating pressure of the pipeline using leak detection fluids or leak detection instruments. Engineering may specify gauge tests prior to tapping on critical applications.

13.2 – Component does not have to be strength tested to substantiate MAOP:

13.2.2 Item 1. – thread-o-let replaces weld-o-let. Specified it is service tees with mechanical connection.

Removed valve tee, Reinforcing saddle, Full encirclement split sleeve and Plidco Split+Sleeve.

14.0 Test Records

14.1.1 – Inserted a new Item 5. – A separate leak test is not required

when hydrostatic pressure testing lines or facilities.

14.1.2 – New Item 3. The Hydrotest Strength Test Form (PTST 3 Form 03) is included with projects generated by Gas Tech Engineering or Gas Storage Engineer when hydrostatic pressure testing is required.

14.2.1 – Added - or Hydrotest Strength Test Form

14.2.2 - Added - or Hydrotest Strength Test Form

14.2.3 – Item 11 - NOTE added – When hydrostatic test is being performed, location of the pressure recording devices shall be recorded and maintained in the final as constructed job packet.

	<p>14.2.3 – Item 14 a. – Pressure fluctuations that occur during the test must be approved by Integrity Management, GTE or GSE prior to acceptance of the test.</p> <p>Removed the Temperature factor formula.</p>		
<p>PTST 1.1</p>	<p>Test Pressure and Duration Tables</p> <p>1.0 Purpose</p> <p>PE2708 (MDPE), PE4710 (HDPE) replaces PE</p> <p>2.0 Tables</p> <p>2.2 – Appendix B – Plastic Main – All PE Pipe Sizes Thru 12" with Design MAOP 125 psig or less.</p> <p>Appendix A Service Line Less than 2", Plastic or Steel:</p> <p>HDPE - Design MAOP changed to 125 psig, minimum test pressure 188 psig, maximum test</p>	<p>April 1, 2021</p>	<p>October 1, 2021</p>

**pressure 260
psig.**

**Added Note
(3) – Maxi-
mum pres-
sure shall be
lowered to
below 200
psig within 2
hours to
avoid dam-
age to meter
valve.**

**Appendix B
– HDPE –
Design
MAOP
changed to
125 psig,
minimum
test pres-
sure 188
psig, maxi-
mum test
pressure 260
psig.**

**Added Note
(2) – 2 inch
and larger
service lines
with 175 psi
rated meter
valves shall
not be ex-
posed to
pressures
greater than
200 psig for
more than 2
hours. Refer
to PTST 1
Paragraph
10.6.1 for
meter valve
limitations.**

Appendix D –
Steel Main –
All Steel
Pipe, With
Design
MAOP 100
psig or
Greater.

**D-5 – Added
– Only a strength test is required when hydrostatic pressure test is performed.**

Table D - Correction in ≥ 100 psig AND $< 20\%$ SMYS

Note (3) – New – Leak test is required when non-hydrostatic testing is performed.

Appendix E – Fabricated Unit/Assembly or Short Sections of Pipe

E-2 – Added – steel

E-4 – Added – Only a strength test is required when hydrostatic pressure test is performed.

E-9 – Added – or 125 psig or less for PE pipe.

Table E(1) Title - Added – or 125 psig or less for PE pipe.

Table E(1) – Design MAOP – 125 psig, Minimum Test Pressure – 188 psig,

	<p>Maximum Pressure 260 psig.</p> <p>E(10) & Table E(10) Title – Revised</p> <p>Short Sections of Steel Pipe</p> <p>E-10 Table E(2) – Inserted new category - $\geq 20\%$ SMYS AND $< 30\%$ SMYS.</p> <p>Note (5) - Leak test is required when non-hydrostatic testing is performed.</p>		
<p>PTST 2.1</p>	<p>Leak Test</p> <p>4.0 General</p> <p>4.2 – Combination leak/strength tests:</p> <p>4.2.1 – Revised - 125 psig or 60 psig for PE segments.</p> <p>5.0 Leak Test Duration</p> <p>5.2 – 125 replaces 100 psig for HDPE.</p> <p>5.2.4 – Revised – The leak test pressure can be left on longer than the required test duration with the possible exception for service lines.</p>	<p>October 1, 2020</p>	<p>October 1, 2021</p>

	<p>1. New – Service lines with 175 psi rated meter valve that are being leak tested at a pressure greater than 200 psig shall have a maximum duration of no more than 2 hours. The test pressure shall be relieved or lowered to under 200 psig within 2 hours. Refer to PTST 1 Paragraph 10.6.1 for meter valve limitations.</p>		
<p>PTST 2.3</p>	<p>Hydrostatic Pressure Testing 2.0 Scope Section 7.0 – Prior to Hydrostatic Testing – Title change 4.3 – New – A separate leak test is no required for hydrostatic pressure testing. 7.0 Prior to hydrostatic Testing – Name change Removed language requiring test gauges at</p>	<p>April 1, 2021</p>	<p>October 1, 2021</p>

UNCONTROLLED IF PRINTED

	<p>highest and lowest points of pipeline being tested.</p> <p>9.0 Pressurizing</p> <p>9.2.2 – Revised - If pressure drops at first and then levels off, the cause is due to a change in the water temperature inside the pipe.</p> <p>9.3.2 – Removed 'project name"</p> <p>11.0 Spike Hydrostatic Pressure Test for Transmission Lines</p> <p>11.1.1 Item 3 – Revised – Hold at or above baseline test pressure for a minimum of 8 hours.</p> <p>12.0 Test Records</p> <p>12.1 – Hydrotest Strength Test Form replaces LSTF (Leak Strength Test Form.</p>		
PTST 2.4	<p>Nitrogen Pressure Testing</p> <p>2.0 – Removed Section 8.0 Tube</p>	October 1, 2020	October 1, 2021

	Trailer Re- quirements		
PTST 2.5	<p>MAOP Determination</p> <p>5.0 MAOP for Steel or Plastic Pipelines</p> <p>5.2 – Clarified – steel pipelines.</p> <p>5.4 – New – For in-service PE pipelines the MAOP is the test pressure divided by a factor of 1.5.</p>	October 1, 2020	October 1, 2021
PTST 2.6	<p>Welded Fabricated Units and Pressure Vessels</p> <p>This section provides the procedures to meet the requirements for units fabricated by welding and pressure vessels installed or relocated on or after October 1, 2021. Procedures address both; fabricated units tested in accordance with Part 192 Section J Testing Requirement and pressure vessels fabricated and tested</p>	New	October 1, 2021

UNCONTROLLED IF PRINTED

	<p>under the ASME Boiler and Pressure Vessel Code. This sections provides examples of fabricated units and pressure vessel commonly installed within AIC's gas systems and gas storage facilities. Pretested fabricated units or manufacturer tested pressure vessels are required to have a documented inspection once they are in their final location and before being placed in operation. Procedures also address the testing requirements for existing fabricated units or pressure vessels which are being relocated to a different facility.</p>		
<p>PTST 3</p>	<p>Forms and Reference Materials Forms:</p>	<p>October 1, 2020</p>	<p>October 1, 2021</p>

UNCONTROLLED IF PRINTED

	Added Hydrotest Strength Test Form		
PUBL 2.2	Liaison with Public Officials 5.0 Periodic Contact 5.4 – Changed Paradigm meetings are held during the 1st quarter of each year.	October 1, 2020	October 1, 2021
PUBL 3	Forms and Reference Materials Updated: Natural Gas Safety Flyer Added: Natural Gas Scratch n Sniff Insert Ameren Illinois Important Safety Message About Hidden Hazards. Contractor Electrical and Natural Gas Safety Information. Overhead Power Line Safety Information.	October 1, 2020	October 1, 2021
PURG 1	Requirements 7.0 Abandonment 7.3 – Revised: In lieu of a Purge Stamp, the Construction Plan can contain a	October 1, 2020	October 1, 2021

UNCONTROLLED IF PRINTED

	<p>purge point table with a sign-off for each point.</p> <p>Operator Qualifications - Added</p> <p>1371 – System Control Center Operations</p> <p>1381 – Local Facility Remote Control Operations</p>		
PURG 2	<p>Methods</p> <p>4.0 Safety</p> <p>4.3 – Revised – Ensure fire extinguisher is on the job-site when a main or service line is being purged.</p>	April 1, 2021	October 1, 2021
QUAL 0	<p>Table of Contents</p> <p>QUAL 1: Changed title of Section 3 – Quality Assurance Bulletin</p>	January 1, 2018	October 1, 2021
QUAL 1	<p>Requirements</p> <p>1. Objectives</p> <p>1. A. – Clarified – reviewing field activities and work processes.</p> <p>1. B. (4) – "contributing causes" replaces "probable causes"</p> <p>1. B. (5) – "Identify and implement" corrective action.</p>	January 1, 2016	October 1, 2021

**1. B. (5) (b) –
"overall quality"**

2. Program

2. F. – Revised - Quality Assessments conducted by Quality Assurance Consultants will be documented in LocusView. Quality Assurance Consultants will verbally communicate the results of the assessment to the local Supervisor. Communication of assessment results with the local Superintendent, will take place when deficiencies are discovered during assessments, and with Gas Compliance and OQ Staff where deficiencies involve improper performance

	<p>of a covered task.</p> <p>2. G. - The QA Assessment report includes (as applicable)</p> <p>2. G. (1) – Summary of the assessment</p> <p>2. H. – Updated - documentation will be through LocusView forms.</p> <p>3. Quality Assurance Bulletin replaces Action Matters Bulletin</p>		
QUAL 4	<p>Forms and Reference Materials</p> <p>Updated Form 20 – NDT Radiographic Inspection</p>	December 1, 2020	October 1, 2021
REGS 1	<p>Requirements</p> <p>5.0 – Engineering Evaluation</p> <p>Removed 5.4 – Calculations can be performed manually or by using evaluation function in Maximo.</p>	October 1, 2020	October 1, 2021
REGS 2.1	<p>Regulator Station Inspections</p> <p>Target Audience – Added Gas Control</p> <p>6.0 Operational Inspection</p>	October 1, 2020	October 1, 2021

6.2 Valve Operation

6.2.1 – Revised – Remove existing locking or security devices

....

6.3 Regulator Station with Relief Valve

6.3.7 Item 11 – Revised – Verify the isolation valve to the relief valve is in the open position and locked, secured or operator removed to prevent unauthorized operation.

6.3.8 Item 3. - Revised – Verify bypass valves are closed, isolation valve to the relief valve is open and the valves are locked, secured or operator removed to prevent unauthorized operation.

Added – NOTE: Heater by-pass valves may be left open or closed seasonally. These valves should be verified for correct sea-

	<p>sonally position during final inspection. Refer to REGS 2.4 Heaters</p> <p>Operator Qualifications – Added:</p> <p>1371 – System Control Center Operations</p> <p>1381 – local Facility Remote Control Operations</p>		
REGS 2.2	<p>Bypass Operations</p> <p>Target Audience – Added Gas Control</p> <p>Operator Qualifications – Added 1371 – Systems Control Center Operations</p>	October 1, 2020	October 1, 2021
REGS 2.3	<p>Troubleshooting Common Regulator Problems</p> <p>8.0 Before Leaving the Regulator Station</p> <p>8.1.6 – Revised – Verify the relief valve is on, set pressure is correct and the isolation valve is open, locked, secured or operator removed to prevent unauthorized operation.</p>	October 1, 2020	October 1, 2021

<p>REGS 3</p>	<p>Regula- tor Sta- tion De- sign 6.0 Stan- dard- ized De- sign Fea- tures 6.3 – Add link to PRES 1 Sub- section 5.1 Pres- sure Moni- toring Loca- tions. 6.13 – For above grade sup- ports, I- Rods or Nu- Bolts are the pre- ferred method for pro- viding against atmos- pheric corro- sion and electri- cal shorts. Refer to CORR 2.7 Sub-</p>	<p>Oc- to- ber 1, 2020</p>	<p>Oc- to- ber 1, 2021</p>
--------------------------	--	--	--

	section 12.2.		
REPR 1	Re-quire-ments Target Audi-ence – Added Gas Control 4.0 General 4.13 Safety consid-erations 4.13.3 – New – A fire ex-tin-guisher shall be at the location of the work when there is a po-tential for an igni-tion. 7.0 Trans-mission and High Pres-sure Distribu-tion Pipe Repair 7.5 – New – Pro-vides a process to be fol-lowed	April 1, 2021	Oc-to-ber 1, 2021

UNCONTROLLED IF PRINTED

when Pipeline Integrity, GTE or GSE recommends a repair method that is not listed as an approved method in Appendix A.

7.7
Transmission and High Pressure Distribution Pipe Grinding Repair

7.7.6 – Revised - Ensure a minimum 10 pound dry chemical (A, B, C) fire extinguisher is present at the location of the work when grinding on an op-

**era-
tional
line.**

8.0
Steel
Distribu-
tion
Pipe
Repair

8.3 Dis-
tribution
Pipe
Grinding
Repairs

**8.3.4
Revised
- En-
sure a
mini-
mum 10
pound
dry
chemi-
cal (A,
B, C)
fire ex-
tin-
guisher
is
present
at the
location
of the
work
when
grind-
ing on
an op-
era-
tional
line.**

9.0 PE
Pipe
Repair

9.1
General

**9.1.4 –
New –
Ensure
a mini-
mum 10
pound
dry**

	<p>chemical (A, B, C) fire extinguisher is present at the location where work is being performed.</p> <p>Appendix C – Dresser Reinforcing Split Sleeves C-2 Style 220 – Removed the 3", 1540 psig rated sleeve. AIC no longer stocks this sleeve. Operator Qualifications – Added – 1371 – System Control Center Operations</p>			
<p>REPR 2.2</p>	<p>Plidco Split+Sleeve Appendix A-2 – Basic Unit:</p>		<p>October</p>	<p>October</p>

UNCONTROLLED IF PRINTED

	<p>Removed the 13" length 12" Plidco Split+Sleeves, 1,000 psig rated.</p> <p>Removed Stock Code 19 33 508, 12" Sleeve, 10-1/2" length, 1,000 psig. Replaced with Stock Code 19 33 506.</p> <p>Appendix A-3 – with 2" Save-A-Valve nipple vent, anodic bolts, silicone packing:</p> <p>Removed all of the sizes that are no longer being stocked by AIC; includes the following sizes: 2", 3", 6", 8", 10".</p> <p>Appendix A-4 – with Buna-N Packing:</p> <p>Removed all of the sizes that are no longer being stocked by AIC; includes the following sizes: 4", 6", 12", 16", 18", 24", 30"</p>	1, 2020	1, 2021
RNST 1	<p>Requirements</p> <p>4.0 General</p> <p>4.1 – Revised to require an engineering evaluation to verify the facilities' integrity and service-ability. Gas en-</p>	April 1, 2021	October 1, 2021

	<p>engineering shall approve reinstatement plans for previously abandoned facilities.</p> <p>4.2 Service lines</p> <p>4.2.1 – Inserted new - Previously abandoned service lines shall not be placed back in service without gas engineering approval.</p> <p>4.3 – Mains</p> <p>4.3.3 – New – Reinstating previously abandoned mains: Refer to Section 8.0 Reinstating Service in Abandoned Mains.</p>		
SAFT 0	<p>Table of Contents</p> <p>SAFT 1.1 Reporting Requirement – New Section</p>	July 1, 2010	October 1, 2021
SAFT 1	<p>Requirements</p> <p>Revisions to SAFT 1 and the addition of SAFT 1.1 were effective May 10, 2021 as a result of IDNR storage field audit.</p> <p>4.0 Regulatory Requirements</p> <p>4.3 Under-ground storage facilities:</p>	May 10, 2021	October 1, 2021

	<p>NOTE: Added – under Illinois Department of Natural Resources' jurisdiction.</p> <p>4.3.6 – Removed reference to pipeline leak classification for underground storage facilities.</p> <p>Operator Qualifications – Added – 1371 – System Control Center Operations</p> <p>Compliance Requirements: Updated link to Title 83, Part 590.</p>		
SAFT 1.1	<p>Reporting Requirements</p> <p>On May 10, 2021 a new section became effective which addresses Gas Storage and Company changes reporting requirements under National Registry of Operators (191.22)</p> <p>Operator Qualifications – Added -1371 – System Control Center Operations</p>	May 10, 2021	October 1, 2021
SERV 1	<p>Requirements</p> <p>10.0 PE Service Lines</p>	April 1, 2021	October 1, 2021

UNCONTROLLED IF PRINTED

10.3 – Revised
– Conduit re-places casing.

10.3.1 – Added reference link to SERV 2.6 Section 7.0 Conduit and Sleeve Insertion Procedures.

10.5 – New-Standard residential service line installation is 1" CTS. 1/2" CTS service lines should only be installed for the following reasons:

10.5.1 Insertion into an existing steel service line.

10.5.2 Repair or replacement of an existing service line.

10.5.3 Service line installation in an existing mobile home.

13.0 Back-Flagging

13.1 – Newly installed AIC gas facilities shall be "back-flagged" as stated in DAMG 1. Paragraph 5.1.4.

Moved the back-flagging details to DAMG 1.

Appendix B-1 & B-2 – Removed the note (Effective January 1,

	<p>2020, Use of Insertion, Repair and Replacement of Existing ½" PE Services)</p> <p>Appendix B-1 through B-5 – Updated maximum MAOP for PE3408/PE4710 to 125 psig.</p>		
SERV 2.1	<p>Capacity</p> <p>Appendix E – Service Line Capacity Tables</p> <p>E-6 – Corrected 1-1/4" Steel Service Line Table.</p>	<p>October 1, 2020</p>	<p>October 1, 2021</p>
SERV 2.2	<p>Excess Flow Valves or Manual Shut-off Valve</p> <p>8.0 Manual Service Line Shut-Off Valve Installation</p> <p>8.1 Location</p> <p>8.1.2 – New – Added - Safely and easily accessible for operations and maintenance.</p> <p>Appendix B EFV Sizing Tables</p> <p>Appendix B-5 – Added maximum length of service line for the 3/4" steel EFVs.</p>	<p>April 1, 2021</p>	<p>October 1, 2021</p>
SERV 2.3	<p>Farm Taps</p> <p>4.0 Farm Tap Requirement</p> <p>4.1 – Updated - 125 psig re-</p>	<p>April 1, 2021</p>	<p>October 1, 2021</p>

	<p>places 100 psig</p> <p>4.7 - Updated - 125 psig replaces 100 psig</p> <p>Added 5 LB Anode to tracer wire on A-1, A-2, A-3</p> <p>Appendix A-1 -3/4" x 6" Sch 80 nipple on high pressure side of regulator.</p> <p>Appendix A-2 Double Cut – Bill of Materials Updated Stock Codes for Street Elbow and 2 – 3/4" Schedule 80 Nipples.</p> <p>Appendix A-3 Double Cut DOT Transmission – Bill of Materials Updated Stock Codes for Street Elbow and 3 – 3/4" Schedule 80 Nipples.</p>		
<p>SERV 2.6</p>	<p>Insertion</p> <p>6.0 Dead Service Line Insertion Procedures</p> <p>6.10 – New – Lay out the new PE service line as straight as possible in order to reduce the drag inside the old service line.</p> <p>6.14 – New - If the inserted</p>	<p>October 1, 2020</p>	<p>October 1, 2021</p>

UNCONTROLLED IF PRINTED

	PE pipe is being pulled through the casing pipe, a weak link shall be used. Refer to POLY 2.3 Section 10.0 Weak Link.		
STLP 1	Requirements 4.0 General 4.3 Material Identification and Verification 4.3.6 – Revised to fittings greater than 2 inch Note – Revised to fittings 2 inch and smaller.	October 1, 2020	October 1, 2021
STLP 2.1	Casing Pipe 4.0 General 4.3 – New – Casing must be designed to withstand external loads.	October 1, 2020	October 1, 2021
TAPS 1	Requirements Target Audience – Added Gas Control Operator Qualifications – Added – 1371 – System Control Center Operations	October 1, 2020	October 1, 2021
TAPS 2.3	Mueller AUTOPERF Tee 6.0 Maximum Pipe Wall Thickness for AUTOPERF Tee. Table 1 – Added Stock Codes	October 1, 2020	October 1, 2021
TAPS 2.4	Mueller Tapping and Stop-	October	October

UNCONTROLLED IF PRINTED

<p>ping Procedures</p>	<p>1, 2020</p>	<p>1, 2021</p>
<p>4.0 General</p>		
<p>4.7 – New – Ensure fire extinguisher is present at the location where the work is being performed.</p>		
<p>Appendix A-3 – Mueller Line Stopper Fittings</p>		
<p>Removed the 3", 6", 8" H-17255, 275 psig fittings</p>		
<p>Appendix A-4 – Mueller Bottom- Out Line Stop- per Fittings:</p>		
<p>Corrected Part Numbers</p>		
<p>Removed 8" H-17281, 720 psig, Mueller Sch 40 Bottom- Out Line Stop- per for Thin Wall Pipe</p>		
<p>Appendix B-1 Service Tees</p>		
<p>Removed 1-1/4" x 2" H-17500, 250 psig Service Tee</p>		
<p>Appendix B-3 Curb Valve Tee Added Note – A 2" square head Operating Head is also available and approved for use.</p>		
<p>Appendix C – Mueller Save-A- Valve Nipple</p>		
<p>Removed 2" x 3" H-17490, 250 psig Nipple.</p>		

<p>TAPS 2.5</p>	<p>T.D. Williamson Tapping and Stopping Pro- cedures</p> <p>2.0 Scope</p> <p>Remove Sec- tion 8.0 – Stop- ple Fittings</p> <p>Removed Ap- pendix A – Stopples Fittings</p> <p>Removed Ap- pendix F – MSTOPP Spherical 3- Way Tee</p> <p>4.0 General</p> <p>4.6 – New - En- sure fire extin- guisher is present at the location where the work is be- ing performed.</p> <p>Section 8.0 Stopples Fittings - Removed</p> <p>Appendix B – SHORTSTOPP 3-Way Tee:</p> <p>Removed 10", 285 psig, Flanged Top 3- Way Tee.</p> <p>Appendix C – SHORTSTOPP Spherical 3- Way Tee:</p> <p>Removed ANCI Class 150, 6", 10", 12", 285 psig, Flanged Tops 3-Way Tees,</p>	<p>De- cem- ber 1, 2020</p>	<p>Oc- to- ber 1, 2021</p>
<p>TAPS 2.6</p>	<p>Supraflow Tee Tapping Pro- cedure</p> <p>4.0 General</p> <p>4.4 – Correc- tion – Maxi-</p>	<p>Oc- to- ber 1, 2020</p>	<p>Oc- to- ber 1, 2021</p>

	<p>mum operating pressure is 150 psig.</p> <p>4.8 – New - Ensure fire extinguisher is present at the location where the work is being performed.</p>		
<p>TAPS 2.7</p>	<p>TDW PE Branch Saddle Valve</p> <p>4.0 General</p> <p>4.5 – New – TDW PE Branch Saddle-Valve can only be installed on PE systems with Design MAOP of 100 psig or less due to the manufacturer's pressure rating.</p> <p>4.6 – New - Ensure fire extinguisher is present at the location where the work is being performed.</p> <p>6.0 PE Branch Saddle-Valve</p> <p>6.1 Table 1 – Corrected 4" description to match EMPRV and MRC.</p>	<p>October 1, 2020</p>	<p>October 1, 2021</p>
<p>TURN 2.1</p>	<p>Residential/ Small Commercial Customer</p> <p>6.0 New Service Connect</p> <p>6.2 A gas meter should be installed</p> <p>6.2.1 – Added – and plugged.</p>	<p>October 1, 2020</p>	<p>October 1, 2021</p>

UNCONTROLLED IF PRINTED

A closed CCV installed and plugged with the meter valve in the on position

7.0 Existing Service Connect

7.4.3 Customer not at home

1. Shut-in test passes:

CCV replaces valve

7.4.3 1c. – Revised – If CCV does not exist, leave off and locked at meter valve.

11.0 Displacement of Air in Fuel Lines

11.4 Bleeding the customer fuel line

11.4.1 – sediment trap replaces drip leg cap.

11.4.4 – hazardous environment replaces hazardous atmosphere.

12.0 Lighting Appliances

12.2 Water Heater

12.2.2 – New – If the water in the heater is frozen, do not light. Leave off and issue a Warning tag as Hazardous Condition.

	<p>12.4 Light any other gas appliance</p> <p>12.4 – Added – If, at the customer's request, an appliance is not to be lit:</p> <p>12.4.1 – Appliance should be left off at the control valve and the lever handle valve, if one is present.</p> <p>13.0 Crawl Spaces</p> <p>13.1 – environment replaces atmosphere</p>		
TURN 2.4	<p>Lighting Appliances and Appliance Safety</p> <p>5.0 Lighting Water Heaters</p> <p>5.3 Existing Installations</p> <p>5.3.3 Item 2. – environment replaces atmosphere</p> <p>5.4 Visual Inspection</p> <p>5.4.3. Item 4 – New – Ensure the water heater is listed for natural gas.</p> <p>5.4.4 Item 4 – Clarified – minimum of 1/4" per foot uphill pitch.</p> <p>5.5 Operational Check for Conventional Water Heater</p>	October 1, 2020	October 1, 2021

	<p>5.5.13 – Revised – After the operational check is completed, return thermostat to the normal temperature setting.</p> <p>5.5.14 – New – Make sure that the Energy Cutoff (ECO) wires are not bypassed.</p> <p>6.0 Lighting Furnaces</p> <p>6.3 Visual Inspection</p> <p>6.3.1 Item 2. – environment replaces atmosphere</p> <p>6.4 Operational Check</p> <p>6.4.8 – Revised – While the blower is still off, observe the flame characteristics from each burner.</p> <p>6.4.11 – "an air disturbance" replaces "a crack or hole"</p> <p>6.4.13 – Revised – After the operational check is complete, adjust the thermostat as needed to ensure furnace cycles.</p>		
<p>TURN 2.5</p>	<p>Combustion and Ventilation Air and Venting Requirements</p> <p>5.0 Venting</p>	<p>October 1, 2020</p>	<p>October 1, 2021</p>

	<p>5.3 Venting Code</p> <p>5.3.1 - Clarified – minimum of 1/4" rise per foot.</p> <p>5.3.4 NOTE – Revised – Exception: A vent connector shall not be connected to a chimney flue serving a fireplace unless the fireplace flue opening is permanently sealed.</p> <p>5.3.5 – flue replaces vent</p>		
<p>TURN 2.8</p>	<p>Changing Meter Valves</p> <p>11.0 Method 7: On-The Fly</p> <p>11.3 On-The-Fly Changing Procedures</p> <p>11.3.1 Item 2 – Updated reference – WIGE 2.2</p> <p>11.3.1 Item 5 – Clarified – Fire extinguisher shall be at the location where work is being performed and manned by one individual while another individual changes the meter valve.</p> <p>Reference Documents</p> <p>Updated – WIGE 2.2 Working in Gaseous Environment</p>	<p>October 1, 2020</p>	<p>October 1, 2021</p>

<p>TURN 2.10</p>	<p>Carbon Monoxide 5.0 Upon Arrival at the Site 5.1 – gas-free environment replaces gas-free atmosphere.</p>	<p>Oc- to- ber 1, 2020</p>	<p>Oc- to- ber 1, 2021</p>
<p>VALT 0</p>	<p>Table of Contents VALT 2.1 – Section 6.0 – Updated – Working in Gaseous Environment</p>	<p>Oc- to- ber 1, 2020</p>	<p>Oc- to- ber 1, 2021</p>
<p>VALT 2.1</p>	<p>Inspecting Vaults and Pits Throughout this section: environment replaces atmosphere WIGE replaces WWBG 4.0 General 4.1 Gas field personnel shall: 4.1.5 Item 3. – Work Area Protection added 4.1.6 – Revised – Have at least 1 fire extinguisher on the jobsite and upwind from the work area.</p>	<p>Oc- to- ber 1, 2020</p>	<p>Oc- to- ber 1, 2021</p>
<p>VALV 1</p>	<p>Requirements 1.0 Purpose: - Added 192.745 and 192.747 6.0 Emergency Valve Inspection Added reference to 192.745 and 192.747 Compliance Requirements – Added</p>	<p>Oc- to- ber 1, 2020</p>	<p>Oc- to- ber 1, 2021</p>

	<p>49 CFR §192.745 Valve Maintenance: Transmission lines</p> <p>49 CFR §192.747 Valve Maintenance: Distribution systems.</p>		
<p>VALV 2.1</p>	<p>Valve Installation</p> <p>1.0 Purpose: Added – 192.145, 192.150 and 192.193</p> <p>6.0 Emergency Line Valves</p> <p>6.1 Transmission Pipelines - Added reference to 192.150 and 192.179</p> <p>6.1.4 – New – Line valves installer within new or replaced transmission lines shall be capable of accommodating the passage of internal inspection devices.</p> <p>6.2 High Pressure Distribution and Distribution Pipelines: Added reference to 192.181</p> <p>7.0 Emergency Station Valves: - Added reference to 192.181.</p> <p>9.0 Valve Installation Operations</p> <p>9.1 Steel Valves – Added reference to 192.145</p> <p>9.2 Polyethylene (PE) Ball Valves: Added reference to 192.193</p>	<p>October 1, 2020</p>	<p>October 1, 2021</p>

	<p>Compliance Re- quirements – Added</p> <p>49 CFR §192.145 Valves</p> <p>49 CFR §192.150 Pas- sage of internal inspec- tion de- vice</p> <p>49 CFR §192.193 Valves installa- tion in plastic pipe</p>		
VALV 2.2	<p>Valve Inspection and Maintenance</p> <p>Target Audience – Added Gas Con- trol</p> <p>Appendix A – Plug Valve Maintenance Table A3 Valve Lu- bricants</p> <p>Removed Rock- well #555 Size B, C, D, Sticks, Val- Tex #80 Size C and D Sticks</p> <p>Operator Qualifi- cations – Added 1371 System Con- trol Center Opera- tions</p>	Oc- to- ber 1, 2020	Oc- to- ber 1, 2021
VALV 3	<p>Approved Valve and Valve Box Accessories</p> <p>Throughout this section removed all of the non-stock coded valves.</p> <p>Updated some Stock Codes and Valve Dimensions.</p>	Oc- to- ber 1, 2020	Oc- to- ber 1, 2021

UNCONTROLLED IF PRINTED

<p>WELD 2.1</p>	<p>Safe Weld- ing Prac- tices</p> <p>5.0 Fire Guard</p> <p>5.2 – Re- vised - The fire guard shall have the proper fire ex- tin- guisher at the loca- tion where welding is be- ing per- formed and be trained in its use.</p> <p>10.0 Ventila- tion</p> <p>10.2 – environ- ment re- places atmos- phere</p>	<p>Oc- to- ber 1, 2020</p>	<p>Oc- to- ber 1, 2021</p>
<p>WELD 2.2</p>	<p>Welder Qualifi- cations</p> <p>Compli- ance Re- quire- ments</p> <p>Typo Correc- tion - ASME</p>	<p>April 1, 2021</p>	<p>Oc- to- ber 1, 2021</p>

	B31.8 re- places ASME B31.3		
WELD 2.5	Visual Inspection Refer- ence Docu- ments Correc- tion - ASME B31.8 Gas Trans- mission and Dis- tribution Piping Sys- tems re- places ASME B31.3 Process Piping	April 1, 2021	Oc- to- ber 1, 2021
WELD 2.8	Liquid Pene- trant Testing 5.0 Liq- uid Pen- etrant Testing Person- nel 5.3 Vi- sion Acuity Record 5.3.1 – Jaegar Num- ber 1 re- places Jaegar Num- ber 2	Oc- to- ber 1, 2020	Oc- to- ber 1, 2021

<p>WELD 2.9</p>	<p>Ultra-sonic Thickness Examination 9.0 Records 9.1 – WELD 4 reference reference replaces reference Appendix A which has been re- moved.</p>	<p>Oc- to- ber 1, 2020</p>	<p>Oc- to- ber 1, 2021</p>
<p>WELD 2.10</p>	<p>Arc burn Removal 4.0 General 4.1.2 – environ- ment re- places atmos- phere</p>	<p>Oc- to- ber 1, 2020</p>	<p>Oc- to- ber 1, 2021</p>
<p>WELD 4</p>	<p>Forms and Reference Materials The GMAW and SMAW WPSs have been reformatted into a one page two sided table form. Where non-essential</p>	<p>Oc- to- ber 1, 2020</p>	<p>Oc- to- ber 1, 2021</p>

UNCONTROLLED IF PRINTED

<p>variables allowed, some previous WPSs have been combined thus reducing the number of weld procedures to 44 (27 SMAWs and 17 GMAWs) from 58 (34 SMAWs and 24 GMAW's).</p>		
--	--	--

Rescission

SUMM - Change Summary, April 1, 2021.

UNCONTROLLED IF PRINTED

Variable "version" is not defined

CHANGE SUMMARY

April 1, 2021

Complete Change Summary			
Document	Change Summary	Previous Document Dated	Current Document Dated
<u>ABND 1</u>	<p>Requirements</p> <p>5.0 Project Specific Procedures</p> <p>5.1 GTE or GTS shall prepare written specific plan.</p> <p>5.1.3. NOTE: Revised – If the abandonment is a result of an emergency project or maintenance project, procedures can be developed as a joint effort between Region engineering and GTE. The Regional Gas Supervising Engineer shall ensure the abandonment job packet is submitted to GTE.</p> <p><i>In emergency situations, local Region Engineer can prepare the procedures with input from GTE. The completed job packet must be sent to GTE for their records.</i></p> <p>Paragraph 5.3.2 Item 7. NOTE: Revised – The responsible Engineer or Engineering group should be consulted with prior to making any significant changes such as: the cut-off location, abandonment method, method to purge.</p> <p><i>Ensures significant changes are reviewed and approved by engineering prior to implementation.</i></p>	October 1, 2020	April 1, 2021
<u>ABND 2.1</u>	<p>Abandonment of Gas Facilities</p> <p>5.1.1 – Revised – Pressure gauges will be installed to monitor the pressure on the remaining system and the section on main to be retired.</p> <p><i>Addition of gauge on the line being abandoned which is needed to monitor purging the gas from that section.</i></p> <p>6.3 Steel Service Lines</p> <p>6.3.6, 3. – Correction - "services" replace "main"</p>	December 1, 2020	April 1, 2021
<u>CNTS 2</u>	<p>Surface Subsidence Areas</p> <p>6.0 Active Surface Subsidence Area</p> <p>6.3.5 Table 1 – Removed 3/4" x 3' Long Flex Braided Connector.</p>	October 1, 2020	April 1, 2021
<u>CONS 1</u>	<p>Requirements</p> <p>4.0 Records, Maps, and Operating History</p> <p>4.1 – local Operating Center replaces Supervisor</p>	October 1, 2020	April 1, 2021

	<p>4.2 – map viewer replaces mapping system</p> <p>4.3 – Revised – Portions of the operating history are typically maintained in Maximo</p> <p>6.0 Responsibilities</p> <p>6.1 – Inserted the word "the" Construction Inspector.</p> <p>7.0 Construction Inspection</p> <p>7.1 – Inserted the word "an" inspector</p> <p>7.1.3 – Inserted "will require a" full time inspector</p> <p>7.1.3. NOTE – Inserted the word "a" full time inspector.</p>		
<u>CONS 2</u>	<p>Inspector Responsibilities</p> <p>4.0 Pre-job Considerations</p> <p>4.2.1 – Revised – Familiarize themselves with the work packet and ensure it includes:</p> <p>4.4 – confirm replaces check – Inspector should confirm that affected customers have been notified.</p> <p>8.0 Record Requirements</p> <p>8.6 – Inserted the word "appropriate" Gas Supervisor</p>	October 1, 2020	April 1, 2021
<u>CORR 1</u>	<p>Requirements</p> <p>15.0 Atmospheric Corrosion</p> <p>15.3 Monitoring of Atmospheric Corrosion</p> <p>15.3.4 – New - 3a. Where preformed FRP spacers are present, pay attention to the presence of cracks in the epoxy or air gaps between the epoxy and the pipe.</p> <p>3b. If rust stains are present, the spacer should be removed and the pipe inspected for corrosion.</p> <p>15.6 Note – New – See CORR 2.7 Subsection 12.2 for additional measures to be taken when pipe is on pipe supports.</p> <p>16.0 Painting Pipeline Facilities</p> <p>16.3.2 Do not paint</p> <p>8. – Correction –Stainless steel control lines, fittings or valves.</p>	October 1, 2020	April 1, 2021
<u>CORR 2.1</u>	<p>Cathodic Protection Design</p> <p>7.0 Insulating Points</p> <p>7.4 bonding</p> <p>Removed 7.4.3 Creating a System Loop – Plastic</p> <p>Tracer wire on plastic loop systems can be continuous with no need for a test station.</p> <p>8.0 Insulating Materials</p>	October 1, 2020	April 1, 2021

	<p>8.4 Insulating Unions Table 3 – Updated stock codes</p> <p>Appendix A insulating Kits for Flanges - Updated Stock Codes</p>		
<u>CORR 2.2</u>	<p>Anode Requirements and Installation</p> <p>6.0 Anode Requirements</p> <p>6.1 Table 3 – Service lines, repaired steel mains and service lines.</p> <p>Changed the threshold for anode installation to -1.0 V from -0.950 V.</p> <p><i>Provides for more time to take corrective action before the line drops to below -0.850 v.</i></p>	October 1, 2020	April 1, 2021
<u>CORR 2.3</u>	<p>Coating</p> <p>Appendix B – Pipe Coating Repair & Fitting Coating Repair</p> <p>Pipe 6 inch and larger can have damaged or bare areas covered without full encirclement wrap.</p> <p><i>Eliminates the need for deeper excavations that are necessary for full encirclement wrapping of pipe. Previously, it was 12 inch and larger pipe that could be repaired without full encirclement wrap.</i></p> <p>Appendix B – Pipe Coating Repair – Added note that wax tape is not acceptable for coating repair.</p> <p><i>Wax tape is susceptible to being displaced during backfilling operations and pipe movement.</i></p> <p>Added links to applicable sections of Appendix I which has the application instructions in the following Appendices;</p> <p>Appendix C – Approved Hot Applied Tapes</p> <p>Appendix D – Approved Cold Applied Tapes</p> <p>Appendix F – Applied Cold Wax Tape</p> <p>Appendix G – Moisture Cured Wrap</p> <p>Appendix E – Approved Field Applied Epoxy Coatings = Corrected size of Denso Protal 7125 Kit to 825 ml.</p> <p>.</p> <p>Appendix G – Moisture Cured Wrap:</p> <p>Corrected size of Polyethylene/Stretch Wrap, 49 22 441, 5" x 200'</p> <p>Appendix H – General Wrapping Instructions</p> <p>3. Service Tee Hot Wrap Tape</p> <p>3. A. Change – Service tee or small fitting installed on 6 and larger steel pipe, hot wrap or epoxy shall cover the exposed bare steel with a 6 inch overlap beyond the bare steel.</p> <p><i>This change eliminates the need for larger excavations to wrap service tees welded on 6, 8, or 10</i></p>	October 1, 2020	April 1, 2021

UNCONTROLLED IF PRINTED

	<p>inch steel pipe. Consistent with changes in Appendix B.</p> <p>4. Service Tees Cold Applied Tape: Added instructions for wrapping service tees with cold applied tapes including wax tape. Clarifies that the cold applied tape or wax tape used to wrap the service tee can be used to cover the bare steel on the main but requires full encirclement wrap of the main.</p> <p>Appendix 1-6 & 1-7 - Wax tape application instructions – Added these are not approved for girth weld coating or pipe coating repair.</p>		
CORR 2.7	<p>Short Investigation and Clearing Shorted Pipeline</p> <p>12.0 Clearing Shorted Pipelines</p> <p>12.1 - Inserted I-Rods and Nu-Bolts as approved insulators.</p> <p>12.2 – New – For above grade applications, I-Rods spacers, Subsection 12.6, and Nu-Bolts, Subsection 12.7, should be used as the preferred method of pipe support insulation. However, if I-Rod spacer or Nu-Bolts will not work for the application, then FRP spacers may be used instead.</p> <p>12.4 Preformed FRP Spacers</p> <p>12.4.2 – Shifted wording – If a FRP insulator is installed on a pipe support</p> <p>12.6 - I-Rods – Installation instructions</p> <p>12.7 – Nu-Bolts – Installation instructions</p> <p>New product to eliminate the possibility of atmospheric corrosion by not allowing water or moisture to collect between the pipe and pipe support</p>	October 1, 2020	April 1, 2021
<u>CORR 2.8</u>	<p>Cathodic Protection Testing</p> <p>Appendix A-9 – AC Stray Current Test Station – Stelth 7 Reference Cell replaces CerAnode Reference Cell.</p> <p>Corrosion Control found Stelth 7 Reference Cell is better than CerAnode Reference Cell and has requested the Stelth 7 be stock coded.</p> <p>Appendix B-7 – Removed Stock Code for Handy Cap,</p> <p>No longer being stocked.</p>	December 1, 2020	April 1, 2021
<u>CORR 2.11</u>	<p>Records</p> <p>Appendix A Cathodic Protection Review Responsibility Table – Updated the Technician/ Specialists listing.</p>	October 1, 2020	April 1, 2021
<u>CORR 3</u>	<p>Forms and Reference Materials</p> <p>Added Borin Stelth 7 Reference Cell Instructions</p>	October 1, 2020	April 1, 2021

<u>DAMG 1</u>	<p>Requirements</p> <p>5.0 Illinois One-Call System</p> <p>5.2.4 - Difficult to Locate Facilities was added.</p> <p>Inserted this section since this section from our O&M was missed and not included Rewrite process,</p>	October 1, 2020	April 1, 2021
<u>EMER 0</u>	<p>Table of Contents</p> <p>Added EMER 2.10 Gas Control</p>	April 1, 2020	April 1 2021
<u>EMER 1</u>	<p>Requirements</p> <p>3.0 Target Audience</p> <p>Added Gas Engineering</p>	October 1, 2020	April 1, 2021
<u>EMER 2.2</u>	<p>Dispatch Center</p> <p>7.0 Cold Weather Electrical Outage and Restoring Service</p> <p>7.1.3 – Correction in customers in High and Moderate Risk systems. 300+ customers in High Risk and 500+ customers in Moderate Risk</p> <p>7.3 Table 1- Contact List for Gas Tech Services and Gas Planning Groups</p> <p>Updated contact information for GTS.</p>	October 1, 2020	April 1, 2021
<u>EMER 2.3</u>	<p>Emergency Responder</p> <p>3.0 Target Audience – Added Gas Engineering</p> <p>5.0 Dispatch to Indoor Odor or Leak</p> <p>In the NOTE, corrected name of Customer Care Center.</p> <p>7.0 Dispatch to Cut Main or Service</p> <p>7.3 – Updated reference to WIGE 2.1 Subsection 6.3</p>	October 1, 2020	April 1, 2021
<u>EMER 2.4</u>	<p>General</p> <p>3.0 Target Audience</p> <p>Added Gas Engineering</p> <p>Appendix A – Replaced 6H screen shot which shows RP for red pin the meter valve.</p>	October 1, 2020	April 1, 2021
<u>EMER 2.4.1</u>	<p>Gas Field Personnel – Dispatched to Indoor Odor or Leak</p> <p>1.13 Check for presence of alternative source of electricity, such as stand-by generator, solar panels, energy storage devices, or wind generators.</p> <p>1. If it can be safely done, disconnect these sources. This may require disconnecting at the device.</p> <p>2. Customers may be able to provide additional information regarding alternative sources of energy.</p>	October 1, 2020	April 1, 2021
<u>EMER 2.9</u>	<p>CNG Trailers</p> <p>5.0 CNG Trailer by Location and Capacity</p>	December 1, 2020	April 1, 2021

UNCONTROLLED IF PRINTED

	<p>Table 1 – Added the 4 larger CNG trailers that have 47.6 MCF @ 3600 PSIG.</p> <p>Updated contact information.</p> <p>10.0 CNG Transportation Requirements</p> <p>Updated AIC Corporate address on Ameren Shipping Paper – CNG.</p>		
EMER 2.10	<p>Gas Control</p> <p>This section was missed in the O&M Rewrite Process</p>	July 1, 2014	April 1, 2021
<u>EMER 3</u>	<p>Forms and Reference Materials</p> <p>Forms: Updated Ameren Shipping Papers - CNG</p>	October 1, 2020	April 1, 2021
<u>INCD 1</u>	<p>Requirements</p> <p>5.0 Natural Gas Incident</p> <p>5.1.3 – Estimated property damage excluding cost of gas lost:</p> <p>1. \$122,000 for incidents reported to PHMSA.</p> <p>2. \$50,000 for incidents reported to IDNR</p> <p>Added NOTE – IDNR 240.1805 – Estimate property damage is the result of a release of stored natural gas from the downhole portion of an underground natural gas storage facility.</p> <p>6.0 Potential Significant Event</p> <p>6.1.3 – A natural gas fueled fire with estimated property damage exceeding \$60,000 for potential reporting to PHMSA or \$25,000 for UNGSF potential reporting to IDNR.</p> <p>Appendix A – Gas Compliance contacted within 1 hour:</p> <p>Separated the estimated cost of property damage values: and</p> <p>Separated the estimated cost of property damage due to gas fueled fire:</p> <p>\$60,000 for potential reporting to PHMSA and ICC.</p> <p>\$25,000 for reporting to IDNR.</p> <p>Appendix B – State and Federal Reporting Matrix</p> <p>Separated the estimated property damage values:</p> <p>\$122,000 for incident reports to PHMSA and ICC.</p> <p>\$50,000 for incidents reports to IDNR.</p> <p>Added NOTE – The estimated property damage value threshold will be adjusted each July 1 beginning in 2022. The adjusted value will be reflected in the next scheduled O&M Update after July 1.</p>	October 1, 2020	April 1, 2021

	PHMSA's Regulatory Reform Rule increase the estimated property damage value to \$122,000 effective March 21, 2021. Under IDNR's regulations for underground natural gas storage facilities, this value remains at \$50,000.		
<u>LEAK 1</u>	<p>Requirements</p> <p>10.0 Leak Surveillance, Repair, and Reevaluation</p> <p>10.3 Class 1 – Revised to provide guidance on what continuous action can be taken until a hazardous condition no longer exists.</p> <p>10.3.1 – Venting may be employed but leak still remains a Class 1 leak.</p> <p>10.3.2 – Leak repairs on compression fittings must follow REPR 2.1 Section 5.0.</p> <p>10.3.3 – Additional actions may be taken to eliminate the hazardous condition with Director approval. The leak remains a Class 1 leak.</p> <p>Continuous action that can be taken to eliminate a Class 1 hazardous condition until approved repair can be made. Leak continues to be a Class 1 until repaired.</p>	October 1, 2020	April 1, 2021
<u>LEAK 2.5</u>	<p>Leak Survey Equipment</p> <p>7.0 Gas Detection Instrument</p> <p>7.9 – Added (± 10%) for 50 ppm test/bump gas.</p> <p>Test gas provider advised Training group that the specification for the test gas is ± 10% and the test gas container will show the actual ppm.</p>	October 1, 2020	April 1, 2021
<u>LEAK 3</u>	<p>Forms and Reference Materials</p> <p>Updated:</p> <p>Leak Investigation Form - Indoor Hazardous Condition of 10% and 30% for Outdoor.</p> <p>Sensit Gold CGI Instruction Manual</p> <p>Sensit Gold C2 Instruction Manual</p> <p>Sensit IRED Manual</p> <p>Added:</p> <p>GAS TRAC LZ 30 Instruction Manual</p>	October 1, 2020	April 1, 2021
<u>MAIN 0</u>	<p>Table of Contents</p> <p>MAIN 3.1 Lateral Taps</p> <p>Changed several of the Section and Appendix titles.</p>	October 1, 2020	April 1, 2021
<u>MAIN 3.1</u>	<p>Lateral Taps</p> <p>2.0 Scope – Removed Subsections in Sections 4.0, 5.0, 6.0 since they are repeated in the individual Sections.</p> <p>4.0 - Changed to PE Tees to PE Pipe</p> <p>5.0 - Changed to Steel Tees to PE Pipe</p>	October 1, 2020	April 1, 2021

	<p>6.0 - Changed to Steel Tees to Steel Pipe Appendix A - Changed PE Tees to PE Pipe Appendix B - Changed Steel Tees to PE Pipe Appendix C - Changed Steel Tees to Steel Pipe Appendix B – Added NOTES: Protective sleeve is required on fittings smaller than 2 inch and optional on fittings 2 inch and larger. Protective sleeves shall be installed as one piece and not split in half. Throughout Appendix B the following sentence was revised: If protective sleeve is installed it shall be placed over the transition fitting. Changes made to Tables and Figure descriptions.</p>		
<p><u>MAIN 3.2</u></p>	<p>End of Main Extension 2.0 Scope – Removed Subsections in Sections 4.0, 5.0, 6.0 since they are repeated in the individual Sections. 5.1 – Changed to Mueller Stopper – Steel to PE Pipe 5.4 – Changed to TDW Stopper – Steel to PE Pipe Appendix B – Added NOTES Protective sleeve is required on fittings smaller than 2 inch and optional on fittings 2 inch and larger. Protective sleeves shall be installed as one piece and not split in half. Throughout Appendix B: Changes made to the titles of Tables and Figures. The following 2 sentences revised: The final tie-in weld shall be butt or socket weld. Socket weld is approved for 2 inch and smaller pipe. If protective sleeve is install it shall be placed over the transition fitting. Appendix C – Revise sentence: The final tie-in weld shall be butt or socket weld. Socket weld is approved for 2 inch and smaller pipe. If necessary, use a transition weld fitting.</p>	<p>October 1, 2020</p>	<p>April 1, 2021</p>
<p><u>METR 1</u></p>	<p>Requirements 7.0 Installation 7.2.2 – Added the system bypass valves, Angle Valve and Brisco valve, currently stocked for 175/250 meter bars.</p>	<p>October 1, 2020</p>	<p>April 1, 2021</p>

	<p>7.4.2. Revised – All meter by-pass valves located upstream of the meter outlet shall be locked closed, when not in use, to deter unauthorized personnel from tampering with the valve.</p> <p>Clarifies bypass valve located upstream of meter outlet is the one that is to be locked closed not a bypass valve located downstream of the meter outlet.</p> <p>8.0 Regulator Vent Lines</p> <p>8.5.4 – Added – Vent lines connected to a regulator spring case or to the outlet side of a relief valve do NOT require pressure testing.</p> <p>Vent lines are to be installed using proper pipe fitting procedures. The lines are not pressure rated and therefore do not require a pressure test.</p>		
METR 2.5	<p>Gas Meter Bypass</p> <p>7.0 Using Portable CNG Tank System with the Mueller Brisco Valve</p> <p>New procedure added since AIC is stocking the Brisco Bypass valve for 175/250 Meter sets.</p>	October 1, 2020	April 1, 2021
METR 2.8	<p>Pressure Factor Metering</p> <p>6.0 Pressure Factor Metering</p> <p>6.4.1 – Added – Twist wire seals are available through Gas Meter Shop or MDF. Electric department wire seals are also acceptable.</p> <p>Regulator spring caps with eyelets can be sealed with twist wire seals</p>	October 1, 2020	April 1, 2021
METR 2.10	<p>Gas Meter Data Sheet</p> <p>1.0 Purpose</p> <p>Added – The GMDS to be compared to the account and the CSS WFM cleared within 90 days of physical transaction.</p> <p>The federal law Sarbanes-Oxley Act of 2002 language which requires companies to develop more stringent checks and balances that impact financials.</p>	October 1, 2020	April 1, 2021
METR 3.2	<p>Regulator Sizing</p> <p>Appendix A – Note (5) – Corrected the Main Spring number for Fisher CS400IR</p>	December 1, 2020	April 1, 2021
METR 3.3	<p>Diaphragm Meter Sets</p> <p>Appendix C – 175/250 Meter, 7"w.c. Delivery, 61 – 100 psig Inlet – Corrected Stock Code and orifice size for the 1" x 1" Itron B42R or American 1813C</p>	October 1, 2020	April 1, 2021
ODOR 0	<p>Table of Contents</p> <p>ODOR 1 – Removed Appendix A – Monthly Odorization Report.</p> <p>The Report form is in ODOR 3</p>	October 1, 2020	April 1, 2021
ODOR 1	<p>Requirements</p>	October 1, 2020	April 1, 2021

UNCONTROLLED IF PRINTED

	<p>2.0 Scope - Removed Appendix A – Monthly Odorization Report.</p> <p>7.0 Monthly Odorization Report</p> <p>7.1 –Link to ODOR 3 replaces link to Appendix A</p>		
<u>ODOR 2.1</u>	<p>Odorant Intensity Sampling and Testing Reference Documents</p> <p>Removed all of the Odorizer reference documents since they are not relevant to odorant intensity.</p>	December 1, 2020	April 1, 2021
<u>ODOR 2.2</u>	<p>Odorization Operations and Transportation Appendix A – Updated AIC Corporate address on Ameren Shipping Paper – Odorant.</p>	October 1, 2020	April 1, 2021
<u>ODOR 3</u>	<p>Forms and Reference Materials</p> <p>Updated Forms:</p> <p>Monthly Odorization Report</p> <p>Ameren Shipping Paper - Odorant</p>	October 1, 2020	April 1, 2021
<u>QQAL 2.01</u>	<p>Covered Task List</p> <p>Change Subsequent Method of Evaluation to P&W/O from W/O on 11 of the Covered Tasks</p> <p>Added the following Cover Tasks :</p> <p>1020 – Perform Electrical Inspection of Pipe Coating (Holiday Detection and Jeeping)</p> <p>1285 – Inspect Water Crossing</p> <p>1681 – Inspect, Test, and Maintain Liquid Knockout (Dehydration) System</p> <p>1691 – Inspect, Test, and Maintain Glycol Dehydration System</p> <p>1701- Inspect, Test, and Mole Sieve Dehydration System</p> <p>Removed the following Covered Tasks:</p> <p>1281 - Mobile Gas Leakage Survey – Optical Methane</p> <p>1421 - Direct Examination Techniques</p>	October 1, 2020	April 1, 2021
<u>QQAL 2.02</u>	<p>Covered Task AOC's</p> <p>Typo Corrections:</p> <p>Joining of Plastic Pipe – Bottom Out Compression Coupling – "not" replaced "left out"</p> <p>Joining of Plastic Pipe – Butt Heat Fusion: Hydraulic Machine – "Misaligned": replaced "Misaligned"</p>	October 1, 2020	April 1, 2021
PCBH 2.01	<p>Inspection of Residential and Commercial Properties</p> <p>1. Administration and Scheduling</p> <p>1. D. – Updated the directions to finding PCB Safety Guidelines – Co-Worker Connect, Business Segments/Ameren Services/Environmen-</p>	January 1, 2011	April 1, 2021

	<p>tal Services/Waste Management/PCB Management.</p> <p>3. Field Procedure</p> <p>3. A. (2) – Updated the location of approved PPE.</p> <p>Co-Worker Connect, Business Segments/ Ameren Illinois/IL Safety/PPE & Safety Equipment/PCB Equipment/Pigging and PCB PPE.</p> <p>3. A. (3) – Ameren Spill Hot Line replaced emergency pager.</p> <p>3. B. (4) – Added link to PCBH 2.03 for Liquid Release Protocol.</p> <p>3. D. (2) – Added location and phone number for the UEC Laboratory Services.</p>		
PCBH 2.02	<p>Positive PCB Detection</p> <p>1. Procedure</p> <p>1. A. – Updated – Ameren Environmental Support and Waste Management, 314-554-2233.</p> <p>1. H. – Added – Materials that may be needed would include such items as:</p> <p>Removed PPE column from the table since approved PCB PPE is on the Ameren IL Safety SharePoint site. Instructions on to access the SharePoint site is in PCBH 2.01.</p>	January 1, 2011	April 1, 2021
PCBH 4	<p>Forms and Reference Materials</p> <p>Updated Forms:</p> <p>PCB Fact Sheet</p> <p>Sampling Inspection Form</p>	January 1, 2011	April 1, 2021
<u>PMRK 2</u>	<p>Pipeline Facility Markers</p> <p>6.0 Pipeline Marker Signs (Appendix B)</p> <p>6.4 - New - Navigable Water Crossing Sign (Appendix B-4)</p> <p>Appendix B-4 – Navigable Water Crossing Sign</p> <p>(stock Code 16 02 606) – New Do Not Anchor or Dredge sign with mounting kit.</p> <p>New sign and mounting kit can be ordered through MDF on an "as requested" basis. New sign replaces existing signs as they are schedule to be replaced.</p>	December 1, 2020	April 1, 2021
<u>POLY 0</u>	<p>Table of Contents</p> <p>POLY 2.1 Section 4.0 – Design Pressure replaced Design Formula.</p>	October 1, 2020	April 1, 2021
<u>POLY 2.1</u>	<p>Design Pressure</p> <p>4.0 Design Pressure – Pressure replaced Formula</p> <p>Subsection 5.2 - Pressure replaced Formula</p> <p>5.2 Table 2 Design Temperature for HDB Value</p> <p>Added 12 inch with Design Temperature of 73 °F.</p>	October 1, 2020	April 1, 2021

Appendix A-2 – Added 8 inch and 12 inch PE 4710 to the Stock Coded pipe table.			
<p><u>POLY 2.2</u></p>	<p>Squeeze Off</p> <p>5.0 Operation</p> <p>5.2 Squeeze Off Tool Location and Operation</p> <p>5.2.2 – Removed the minimum 12 inch from any fusion joint, saddle fusion, mechanical connection or previous squeeze off location.</p> <p>Table 1 – New – Provides the minimum distance, 3 time the OD of the pipe, the squeezer shall be from a fusion joint, mechanical connection, previous squeeze point or second squeeze tool.</p> <p>5.2.5 – Removed the 12 inches.</p> <p>ASTM eliminated the 12 inch minimum so the squeeze off tool only has to be 3 pipe diameters away from joints, etc.</p> <p>6.0 Above Grade Squeeze</p> <p>6.4 – Hazardous gas environment replaces blowing gas atmosphere and updated reference to WIGE 2.1.</p>	<p>October 1, 2020</p>	<p>April 1, 2021</p>
<p><u>POLY 2.3</u></p>	<p>Installation Requirements</p> <p>6.0 Support</p> <p>6.3.3 – Revised – Protective sleeves shall be installed on the outlet of service tees in accordance with SERV 1 Appendix B and on steel-to-plastic transition fittings in accordance with MAIN 3.1 and MAIN 3.2.</p> <p>The referenced Appendices contain the new policy that; protective sleeves are required on fittings smaller than 2 inch and are optional on 2 inch and larger fittings.</p> <p>9.0 Minimum Bending Radius</p> <p>9.2 Table – Added the 12 inch PE pipe.</p> <p>10.0 Weak Link</p> <p>10.1 – Added – Weak Link is required when pulling pipe in by hand.</p> <p>10.2.1 – PE pipe size 1" CTS or smaller:</p> <p>Only acceptable weak link methods are:</p> <ol style="list-style-type: none"> 1. Cutting approximately half of the diameter of the pipe, or 2. Using a commercially manufactured weak link device. 3. Weak link is required when pulling pipe by hand. <p>Removed using larger diameter pull plug or larger bore head/back reamer.</p> <p>Using larger diameter pull plugs, drill head, back reamers are not considered weak link methods ac-</p>	<p>December 1, 2020</p>	<p>April 1, 2021</p>

	<p>ording to the ICC's interpretation and had to be removed from the O&M. In addition, a weak link is also required when pulling the pipe in by hand.</p> <p>10.3 Table 6 - Added 1/2" PE 4710 Cumberland weak link.</p>		
<u>POLY 2.4</u>	<p>Butt Fusion</p> <p>6.0 Safety – Before Starting Fusion Operation</p> <p>6.5 Checking heat iron</p> <p>6.5.2 – Temperature shall be checked replaced Temperature check readings.</p> <p>8.0 Joint Assembly</p> <p>8.1.1 – Revised - Ensure pipe ends are clean prior to placing in butt fusion machine. If needed, clean with water, alcohol solution or clean rag/towel.</p> <p>Table 1 Melt Bead Size – Added 12" fittings</p> <p>Appendix A – Butt Fusion Fittings – Added 12 " fittings</p>	December 1, 2020	April 1, 2021
<u>POLY 2.5</u>	<p>Electrofusion</p> <p>4.0 Common Requirements</p> <p>4.1.3 – Added – Electrofusion is required when joining:</p> <p>PE pipe with different wall thickness that exceeds one SDR valve, or</p> <p>PE pipe with different chemical properties (e.g. Aldyl A to MDPE)</p> <p>Added because the O&M states these pipes could not be Butt Fused but did not state how they were to be joined.</p> <p>4.2.1 – 3. All alcohol used on PE pipe shall be at least 96% isopropyl alcohol.</p> <p>Was left out in the Rewriting process.</p> <p>8.0 Pipe Surface Preparation</p> <p>8.1.3 – Maximum Gap Information from Subsection 10.1 moved to this location. Added 10 and 12 inch pipe to Table.</p> <p>Applicable to when cutting pipe ends square.</p> <p>9.0 Peeling</p> <p>9.1 Note – Hand scraping is allowed only when the use of a rotating peeler is not feasible and must be approved by the Gas Supervisor.</p> <p>Was left out in the Rewriting process.</p> <p>9.5.1 – Maximum number of passes with a peeler:</p> <p>Pipe 2" and smaller – one pass,</p> <p>Pipe 3" and larger – two passes</p>	December 1, 2020	April 1, 2021

	<p>This based on information from Central Plastics to ensure wall thickness is not reduced more than 10%.</p> <p>Appendix A – Added 12 inch electrofusion fittings.</p>		
<u>POLY 3.1</u>	<p>Transition Fittings and Protect Sleeves</p> <p>4.0 Transition Fittings</p> <p>4.3.3 - Added – Protective sleeve is required on fittings less than 2 inch.</p> <p>Protective sleeve is optional for fittings 2 inch and larger.</p> <p>Protective sleeve shall be installed as one piece and not split in half.</p> <p>Discussion with fitting manufacturer and other utilities found that only the smaller diameter service tee fittings and transition fittings need a protective sleeve to provide adequate support from shear forces.</p> <p>Appendix A – Transition Fittings – Added 12 inch PE4710 and Stock Code for the 8 inch PE 4710.</p> <p>Appendix B – Added – Protective sleeve shall be installed as one piece and not split in half.</p>		
<u>POLY 4</u>	<p>Forms and Reference Materials</p> <p>Updated Connectra 28HP Butt Fusion System Operating Manual – Sept, 2018</p>	October 1, 2020	April 1, 2021
<u>PTST 1</u>	<p>Requirements</p> <p>7.0 Test Medium</p> <p>7.1.3 – New – The test medium shall be water for:</p> <ol style="list-style-type: none"> 1. New and replaces transmission lines in an HCA. 2. Assesment for manufacturing and construction defects in an existing transmission line within a HCA. <p>New or replaced transmission lines installed within 300 feet of a building intended for human occupancy.</p> <p>7.1.4 – New – Water Is preferred test medium for all transmission lines. Other mediums may be used with engineering approval. An example of exception are included.</p> <p>NOTE: Transmission testing requirements do not apply to control lines, service lines or gas regulator stations not considered transmission.</p> <p>PHMSA's EGA Rule for transmission lines requires hydrostatic testing to ensure manufacturing and construction defects are stable. AIC has decided to hydrostatic test all transmission lines to avoid po-</p>	October 1, 2020	April 1, 2021

	tential testing if in the future the line ends up in a HCA.		
<u>PTST 1.1</u>	<p>Test Pressure and Duration</p> <p>Appendix D – Steel Main – All Steel Pipe Sizes thru 30" with Design MAOP 100 psig or Greater</p> <p>D-4 – Revised – GTE or GSE will provide hydrostatic testing plan for transmission lines. Test pressure and duration shall at least meet the minimum shown in Table D.</p> <p>D-5 – New – Facilities classified as transmission based on their function or location even though the MAOP is less than 20% SMYS, shall be hydrostatic pressure tested.</p> <p>Table D – Inserted a new category for testing: 20% SMYS or greater but less than 30% SMYS. Recording Device is Required.</p> <p>30% SMYS or greater – All tests require a Recording Device.</p> <p>Appendix E – Fabricated Unit/Assembly or Short Section of Pipe.</p> <p>E-4 – New – Transmission fabricated units and short sections of pipe, where post installation testing is impractical, a pre-installation hydrostatic pressure test shall be conducted in accordance with Table E(2).</p> <p>E-8 – New – When installing a pre-tested fabricated unit at its final location, check for damage including inlets, outlets, and lifting locations. Identify defects such as dents, gouges, bending, corrosion and cracking. If threats are found, conduct non-destructive testing, re-pressure test or repair.</p> <p>Requirements in PHMSA's Regulatory Reform Rule effective March 21, 2021.</p>	October 1, 2020	April 1, 2021
<u>PTST 2.3</u>	<p>Hydrostatic Pressure Testing</p> <p>4.0 General</p> <p>4.2 – New – Reference PTST 1 Section 7.0 Test Medium for test medium requirements.</p>	October 1, 2020	April 1, 2021
<u>PURG 2</u>	<p>Methods</p> <p>6.0 Purging of Gas with Air During Abandonment</p> <p>6.2 – Added – Do not exceed MAOP. Adhere to manufacturer's published operating pressure limits and practices, when using control fittings.</p> <p>8.0 Required Minimum Inlet Pressures</p> <p>8.1 – Added – Adhere to manufacturer's published operating pressure limits and practices, when using control fittings.</p>	December 1, 2020	April 1, 2021

	<p>Eliminates the potential over pressurizing the plugging unit causing it move allowing compressed air into the active gas system.</p>		
<p><u>REPR 1</u></p>	<p>Requirements</p> <p>4.0 General</p> <p>4.2.2 – Typo correction – Type of defect or damage.</p> <p>4.13 – Gaseous environment replaces atmosphere and updated reference to WIGE 2.1</p> <p>6.0 Common Repair Considerations Steel Pipe</p> <p>6.7 Encapsulation</p> <p>Added a NOTE: Full encirclement split sleeve and Plidco Split+Sleeve are covered in Subsection 6.3 or Subsection 6.4.</p> <p>This is to distinguish between the two methods of encapsulation.</p> <p>6.7.1 Item 2. – This is referred to as pipe/cap method.</p> <p>6.7.4. Item 1 – Removed "back welding" of steel cap. It now states "tack welding" of steel cap.</p> <p>7.6 High Pressure and Transmission Pipe Grinding Repair.</p> <p>Added a new section with grinding procedures for repair of transmission and hp distribution pipe defects.</p> <p>8.0 Steel Distribution Pipe Repair</p> <p>8.2.2. – Caution added – Half-sole sleeve must extend beyond the area of lamination and weld to sound pipe.</p> <p>8.3 – Distribution Pipe Grinding Repairs</p> <p>Added a new section with grinding procedures for repair of distribution pipe defects</p> <p>11.0 Repair Records</p> <p>11.3.1 – Non-destructive testing (NDT) replaced radiographic testing.</p> <p>Appendix A – Transmission & High Pressure Distribution Pipe Repairs</p> <p>Appendix A Notes:</p> <p>Note 3 – Revised – Grinding requirements to be specified by engineering. See Subsection 7.6.</p> <p>Note 7 – Added link to WELD 2.3 Section 10.0 for weld deposition.</p> <p>Appendix B Steel Distribution Pipe Repairs</p> <p>Appendix B Notes:</p> <p>Note 3 – Revised – The remaining wall thickness after grinding must be equal to or greater than nominal wall thickness required for the design pressure of the pipeline. See Subsection 8.3.</p>	<p>October 1, 2020</p>	<p>April 1, 2021</p>

	<p>Appendix D Mueller Tapered Screw Plug D-2.5 – Added – or encapsulated with a pressure rated cap. See Subsection 6.7 for encapsulation.</p>		
SERV 1	<p>Requirements</p> <p>4.0 Depth of Service Line</p> <p>4.1 – Revised – Service line depth for service lines smaller than 2 inch shall be a minimum of 18 inches from top of pipe to finished grade and should be a minimum of 24 inches for service lines 2 inch and larger.</p> <p>Added NOTE: Service lines 2 inch and larger, the minimum cover depth as the service line approaches the service riser will be determined by the maximum bury depth of the service riser.</p> <p>SMR team felt it prudent to install the larger service line a little deeper as added protection due to larger volume of gas in these line. The increased depth would allow for addition services to be attached which may result in the service line being classified as a main.</p> <p>Appendix B-1 through B-4 – Added link to POLY 3.1 Appendix B for protective sleeve installation.</p> <p>Appendix B-5 Note 6 – Added – Protective sleeve is optional for 2 inch and larger services. If a protective sleeve is installed, it shall be placed over the connection between the tee and the service pipe.</p>		
SERV 2.2	<p>Service Line Installation EFV and Manual Valve</p> <p>6.0 EFV Sizing</p> <p>6.1 – Changed "shall" to "should"</p> <p>6.2 – New – For existing odd size service lines such as 1-1/4", 1-1/2" or 3", Gas Engineering will evaluate the service and determine if there is a small size EFV that would meet the service specifications and load requirements at that location.</p> <p>6.2.1 Examples may include:</p> <p>1/2" CTS EFV on a 3/4" IPS PE service line.</p> <p>1" CTS EFV on a 1-1/4" IPS PE service line.</p> <p>2" IPS EFV on a 3" IPS PE service line.</p> <p>3/4" IPS EFV on a 1-1/2" IPS steel service line.</p> <p>EFVs for odd size pipe are not stocked but in most cases a small size EFV will handle the load. This also why the "shall" was changed to a "should" to allow for the mismatch between the EFV and pipe</p>	December 1, 2020	April 1, 2021
SERV 2.3	<p>Farm Tap</p> <p>Appendix A-1 through A-3 - Upgraded Schedule 40 fittings and malleable iron fittings to either</p>	December 1, 2020	April 1, 2021

UNCONTROLLED IF PRINTED

	<p>Schedule 80 or forged steel in each of the farm tap standards.</p> <p>Specifying all high pressure fittings minimizes the chance installing a lower pressure fitting when building a farm tap set.</p> <p>Appendix A-3 – Updated drawing to show location of the reducing tee on top of pre-bent an-odeless riser.</p> <p>Appendix A-3, Pre-fabricated Assembly #3 – Updated drawing to correctly show items 8, 31, 32, 33.</p>		
<u>STLP 2.2</u>	<p>Design Pressure</p> <p>Appendix A – Corrections:</p> <p>Stock Code 32 23 351 – to DRL</p> <p>Stock Code 32 23 377 – to X52</p>	October 1, 2020	April 1, 2021
<u>STLP 3.1</u>	<p>Weld Fittings</p> <p>Appendix A – Elbows - Corrections</p> <p>Long Radius Elbow, 35,000 psig SMYS:</p> <p>Stock Code of 4 inch</p> <p>Wall Thickness of 6 inch</p> <p>Appendix C – Tees – Correction</p> <p>Straight Tees, 52,000 psig SMYS</p> <p>Stock Code 16 inch</p> <p>All tees are bare, removed the coating designation and Note.</p> <p>Appendix D - Reducing Tees and Concentric Tees, 52,000 psig, SMYS:</p> <p>Wall Thickness correction for 12" x10"</p> <p>New – 16" x 6"</p> <p>Appendix E – Caps</p> <p>Weld Caps, 32,000 psig SMYS:</p> <p>Removed 18 inch cap</p> <p>Weld Caps, 52,000 psig SMYS:</p> <p>Wall Thickness correction for 18 inch.</p>	October 1, 2020	April 1, 2021
<u>STLP 3.2</u>	<p>Reinforcing Saddles</p> <p>Appendix A – Saddles:</p> <p>Corrected Outlet of 3 inch.</p>	October 1, 2020	April 1, 2021
<u>STLP 3.3</u>	<p>Flanges</p> <p>Appendix G-3 – Insulating Gaskets for Steel Flanges and Fittings</p> <p>Corrected Stock Codes for:</p> <p>1-1/4" Type F, Class 600</p> <p>2" Type F, Class 300</p> <p>3" Type F, Class 300</p> <p>Stocks Coded Insulating Gaskets for these 3 are actually Insulating Kits.</p>	October 1, 2020	April 1, 2021
<u>TURN 2.3</u>	<p>Discontinuance or Transfer of Gas Service</p>	October 1, 2020	April 1, 2021

UNCONTROLLED IF PRINTED

	<p>6.0 Soft Disconnect 6.2 – Typo – Remove "or"</p>		
<u>WELD 2.2</u>	<p>Welder Qualification 12.0 Records and Retention 12.2 – Removed the requirement for welder to carry their qualification card. Welder is responsible for having their Weld Qualification Report available for review. <i>ICC inspector only wants to see the welder's Weld Qualification Report.</i></p>	October 1, 2020	April 1, 2021
<u>WELD 2.4</u>	<p>In-Service Welding Header – Corrected spelling - Service</p>	October 1, 2020	April 1, 2021
<u>WELD 2.5</u>	<p>Visual Inspection 4.0 Inspection Requirements 4.5.5 Cap Pass 5 g. – Spelling corrections – burns and burn</p>	October 1, 2020	April 1, 2021
<u>WELD 4</u>	<p>Forms and Reference Materials Updated Form 02 – Ultrasonic Thickness Report Form V0.041 Reference Material: Electronic version of Reference 67 GMAW-Ameren-W007 HW needs heading corrected – HW not NW.</p>	May 15, 2020	April 1, 2021
WIGE	<p>Working In Gaseous Environment (WIGE) has replaced Working With Blowing Gas (WWBG) The WWBG hyperlinks in the O&M will not work after this O&M Update. Corrections will be made for the October 1, 2021 Update.</p>		May 15, 2020
WIGE 0	<p>Table of Contents Header change – Working In Gaseous Environment WIGE replaces WWBG WIGE 2.1 – Added a Section 8.0</p>	October 1, 2020	May 15, 2020
WIGE 1	<p>Working In Gaseous Environment – Requirements 1.0 Purpose Modified to working in an outdoor environment that is considered hazardous due to gas-in-air. 4.0 General 4.2 – Hazardous outdoor environment is a gas-in-air concentration equal to or greater than 30% LEL (1.5% natural gas) 4.3 – New – Gas field personnel shall monitor gas-in-air reading with a gas detection instrument when the gas-in-air is capable of causing harm to life and/or property by ignition or suffocation.</p>	October 1, 2020	April 1, 2021
WIGE 2.1	Hazardous Environment	December 1, 2020	April 1, 2021

UNCONTROLLED IF PRINTED

	<p>Throughout this section, Hazardous environment due to gas-in-air replaced Hazardous atmosphere due to blowing gas.</p> <p>This section must be totally reviewed by all gas personnel since the concept of blowing gas has been replaced with a detectible gas-in-air concentration as quantified with a gas detection instrument..</p>		
WIGE 2.2	<p>Personnel Protective Equipment</p> <p>1.0 Purpose</p> <p>Slightly modified by replacing atmosphere with environment that is considered hazardous due to gas-in-air.</p> <p>4.0 General</p> <p>Table 1 - Added a couple of new models of single layer FR coveralls, updated model of Silver Needle insulated FR Hood and update Supplied Air Equipment.</p>	October 1, 2020	April 1, 2021

Rescission

SUMM - Change Summary, October 1, 2020.

UNCONTROLLED IF PRINTED

Variable "version" is not defined

CHANGE SUMMARY

December 1, 2020

Complete Change Summary			
Docu- ment	Change Summary	Previous Document Dated	Current Document Dated
<u>ABND 0</u>	Table of Contents ABND 2.1 – Added Attachment 3 – Polywater AFT Sealant	October 1, 2020	December 1, 2020
<u>ABND 2.1</u>	Abandonment of Gas Facilities Added Attachment 3 – Polywater AFT Sealant	October 1, 2020	December 1, 2020
<u>BORE 2.1</u>	Boring Operations and Pipe Installation 4.3 Prior to Beginning Operations 4.3.2 Added, in accordance with AIC Field Safety Manual provision in Section 33.4. The Field Safety Manual has been updated to reflect additional ICC re- quirements when digging within the tolerance zone. To maintain consis- tency, reference to the Safety Manual is replacing previous O&M require- ments for uncovering facilities within the tolerance zone.	October 1, 2020	December 1, 2020
<u>BORE 2.2</u>	Boring Across or Near Sewer Lines 5.0 Pre-Construction Steps Paragraph 5.2.7 Added, in accordance with BORE 2.1 Subsection 4.3 when exposing a sewer lateral. Paragraph 5.3.2 Added, in accordance with BORE 2.1 Subsection 4.3 when exposing a forced sewer main or lateral. These were added due the changes made to digging within the tolerance zone.	October 1, 2020	December 1, 2020
<u>CLAS 1</u>	Requirement 6.2.1 Correction, 660 feet and 220 yards replaces 600 feet and 200 yards. 6.2.2 Correction, 660 feet replaces 600 feet.	October 1, 2020	December 1, 2020
<u>CNTS 1</u>	Requirements 8.1.10 – Removed the Note which referenced the location of Alcohol and Illegal Drug Policy and the Employee Assistance Program.	October 1, 2020	December 1, 2020
<u>CORR 2.8</u>	Cathodic Protection Testing Appendix B Test Lead Wire Attachment 6. Welded Bolt Anode Wire or Test Lead Connection to Steel Pipe. 6. A. – Wording correction – "with MAOP or 100 psig or less" re- places "operating pressure at or below 100 psig".	October 1, 2020	December 1, 2020
<u>EMER 2.9</u>	CNG Trailers 7.0 Other Equipment 7.1.4 – Added "dry chemical (A. B. C.), 20 pound minimum" to the fire extinguisher.	October 1, 2020	December 1, 2020

UNCONTROLLED IF PRINTED

<u>EXCV 2.01</u>	<p>Prior to Excavation</p> <p>2. Job Preparation</p> <p>2. B. Added, Machine excavating may be utilized in accordance with AIC Field Safety Manual provisions in Section 33.4.</p> <p>Preferably hand or vacuum excavation is used to expose facilities within the tolerance zone but provisions are being added in the AIC Field Safety Manual to allow mechanical excavating in certain situations.</p>	January 1, 2020	December 1, 2020
<u>EXCV 2.03</u>	<p>Working in Excavation</p> <p>1. Beginning Excavation</p> <p>1. F. Added, Machine excavating may be utilized in accordance with AIC Field Safety Manual provisions in Section 33.4.</p> <p>Addition made for same reason as stated for EXCV 2.01.</p>	January 1, 2020	December 1, 2020
<u>EXCV 2.09</u>	<p>Working in Hazardous Atmosphere</p> <p>3. Entering Excavation</p> <p>3. F.: Proposed modification – A properly sized dry chemical (A. B. C.) fire extinguisher shall be at the work site. See WWBG 2.1 Sub-section 4.2.2.</p>	January 1, 2020	December 1, 2020
<u>GLOS</u>	<p>Glossary</p> <p>Tolerance Zone – (for excavating and locating purposes) Added excavating and 18 inches.</p> <p>Tolerance zone is applicable to both excavating and locating operations. Tolerance zone is commonly defined as 18 inches either side of the buried facility rather than 1-1/2 feet.</p>	October 1, 2020	December 1, 2020
<u>LOCT 1</u>	<p>Methods</p> <p>5.0 Locating Methods</p> <p>5.5 Excavate</p> <p>5.5.2 Added, Refer to AIC Field Safety Manual, Section 33.4 Work within the Tolerance Zone.</p>	October 1, 2020	December 1, 2020
<u>PMRK 2</u>	<p>Pipeline Facility Markers</p> <p>Appendix B – (B-3) – Corrected Stock Code</p>	October 1, 2020	December 1, 2020
<u>POLY 2.5</u>	<p>Electrofusion</p> <p>Section 7.2 Table 3 – Added the 10" and 12" PE pipe to the Out of Roundness table</p>	October 1, 2020	December 1, 2020
<u>PURG 2</u>	<p>Methods</p> <p>8.0 Required Minimum Inlet Pressure</p> <p>8.1 – Changed to "Do not exceed MAOP."</p>	October 1, 2020	December 1, 2020
<u>REGS 4</u>	<p>Forms and Reference Materials</p> <p>Correction: RS000 Title Block</p>	October 1, 2020	December 1, 2020
<u>REPR 2.1</u>	<p>Compression Couplings</p> <p>8.0 Records</p> <p>8.2 Updated – PTST 1 Section 14.0</p>	October 1, 2020	December 1, 2020
<u>REPR 3</u>	<p>Forms and Reference Materials</p> <p>Updated Plidco Split + Sleeve Installation instructions.</p>	October 1, 2020	December 1, 2020

UNCONTROLLED IF PRINTED

<u>SERV 1</u>	<p>Requirement Appendix A – (A-3) – Add Residential Meter Set Restriction diagram. This was left out during the conversion.</p>	October 1, 2020	December 1, 2020
<u>SERV 2.2</u>	<p>Excess Flow Valve or Manual Shut-off Valve Section 5.0 EFV Installation and location 5.3.5 (New) – Perform a functional flow test – The requirement to perform functional flow test prior to initiating service was left out during the rewrite process. Have expanded to provide the instructions from UMAC on how to perform the functional flow test EFV manufacturers include a functional flow test in their instructions.</p>	October 1, 2020	December 1, 2020
<u>SERV 2.3</u>	<p>Farm Taps Section 5.0 Farm Tap Location 5.5.1 New – Protective Barricades are available with 2" legs (62 05 159) or 4" legs (62 05 160). Appendix A-3 Double Cut – DOT Transmission Bill of Material Corrected ID – G354101</p>	October 1, 2020	December 1, 2020
<u>TAPS 2.5</u>	<p>T.D. Williamson Tapping and Stopping Procedure Appendix B SHORTSTOPP Welding Fitting 12" ANSI Class 150 Pressure Rating changed to 275 psig for Class 3 locations. Appendix C SHORTSTOPP 3-Way Tee 12" ANSI Class 150 Pressure Rating changed to 220 psig for Class 3 locations. Pressure ratings based on TDW published specifications</p>	October 1, 2020	December 1, 2020
<u>WELD 1</u>	<p>Requirements Section 9.0 Inspection and Test of Welds 9.2.1 – 2. Adding "and the welds are so limited in number that non-destructive testing is impractical." – This is Part 192 code language that was left off during the rewrite process. Language has been in AIC's O&Ms for years.</p>	October 1, 2020	December 1, 2020
<u>WWBG 2.1</u>	<p>Hazardous Atmosphere 4.0 General 4.4.2 – Proposed modification – Ensure that a dry chemical (A.B.C.) fire extinguisher is present near the worksite while working in a gaseous atmosphere. 1. A minimum 20 pound fire extinguisher is required when workers are in Level 2 PPE. The fire extinguisher shall be discharge tested upwind of the worksite. 2. A 10 pound fire extinguisher is acceptable when workers are in standard work clothing or Level 1 PPE. Clarification on fire extinguisher size requirements based on input from Jeff Lott. 6.0 Safe Zone 6.2.2 Added, not including small diameter service lines. This was existing language in the previous O&M but was missed during the rewrite.</p>	October 1, 2020	December 1, 2020

	Reference Link Corrections		
<u>CONF 1</u>	1. A. – VALT now goes to Vault and Pit Inspection section.	January 1, 2011	January 1, 2016
<u>EXCV 2.04</u>	Soil Analysis & Classification 6. Excavation/Soils Checklist 6. D. Removed the Safety Department SharePoint link. Contact the Safety Supervisor for access to the Checklist.	October 1, 2020	December 1, 2020
<u>LOCT 0</u>	Table of Contents Reformatted LOCT 2	October 1, 2020	December 1, 2020
<u>LOCT 2</u>	Forms and Reference Materials Reformatted LOCT 2	October 1, 2020	December 1, 2020
<u>MAIN 2.5</u>	Pipe Coating and Gasket Removal Reference Documents Added – WWBG 2.2 Gas Personal Protective Equipment	October 1, 2020	December 1, 2020
<u>METR 3.2</u>	Regulator Sizing Compliance Requirements Removed the reference link to Title 83 Public Utilities, Part 590	October 1, 2020	December 1, 2020
<u>ODOR 2.1</u>	Odorant Intensity Sampling and Testing Reference Documents Remove reference link for the Becker ACD-300 Charcoal Deodorizer and replaced it with reference to ODOR 3 Forms and Reference Materials	October 1, 2020	December 1, 2020
<u>POLY 2.3</u>	Installation Requirements Updated reference link to the Gas Tools and Equipment, Other PE Tools SharePoint site for the Condux swivel.	October 1, 2020	December 1, 2020
<u>POLY 2.4</u>	Butt Fusion Reference Documents Updated reference link to Performance Pipe PP 750 Heat Fusion Procedures.	October 1, 2020	December 1, 2020
<u>POLY 2.5</u>	Electrofusion Appendix A-9 – Updated reference link to Groebner Supraflow Tapping Tee Technical Data.	October 1, 2020	December 1, 2020
<u>POLY 2.6</u>	Mechanical Joining 5.3 Remove reference link to elster-perfection for chamfer tools.	October 1, 2020	December 1, 2020
<u>POLY 2.9</u>	Plastic Fusion Qualification Reference Documents Updated reference link to Performance Pipe PP 750 Heat Fusion Procedures.	October 1, 2020	December 1, 2020

<u>POLY 3.1</u>	<p>Transition Fittings and Protective Sleeves</p> <p>Appendix A – Transition Fittings</p> <p>Removed reference link to Central Plastic's Transition Fittings flyer</p> <p>Appendix B – Protective Sleeves</p> <p>Removed reference link to Performance Pipe's Protective Sleeves pdf.</p>	October 1, 2020	December 1, 2020
<u>QUAL 4</u>	<p>Forms and Reference Materials</p> <p>Removed Inaccurate or Incorrect Record Notification form</p>	January 1, 2018	December 1, 2020
<u>SAFT 1</u>	<p>Requirements</p> <p>Compliance Requirements – Updated reference link to Title 83 Public Utilities, Part 590.</p>	July 1, 2020	December 1, 2020
	<p>Corrections made to the October 1, 2020 electronic versions that were missed during conversion</p>		
<u>ABND 0</u>	<p>Removed ABND 3 – Items are Attachments to ABND 2.1</p>	October 1, 2020	December 1, 2020
<u>EMER 2.2</u>	<p>Dispatch Center</p> <p>Section 7.0 Table 1 GTS Contact Information- Added South Region contact information</p>	October 1, 2020	October 1, 2020
<u>METR 3.3</u>	<p>Diaphragm Meter Sets</p> <p>Appendix D Table 4 – Corrected Stock Code 39 22 632. Removed the extra 1.</p>	October 1, 2020	October 1, 2020
<u>PURG 1</u>	<p>Requirements</p> <p>Reference Documents – ABND 2.1 replaces ABND 3</p>	October 1, 2020	October 1, 2020
<u>PURG 2</u>	<p>Methods</p> <p>Reference Documents: Removed ABND 3</p>	October 1, 2020	December 1, 2020
<u>REGS 2.1</u>	<p>Regulator Station Inspection</p> <p>Section 11.2 Gas Regulator Station Signage, Danger Sign – Add NOTE back in.</p>	October 1, 2020	October 1, 2020
<u>SERV 1</u>	<p>Requirements</p> <p>Appendix B – (B-1) & (B-2) Added (Effective January 1, 2020: Use for Insertion, Repair or Replacement of Existing 1/2" PE Services)</p>	October 1, 2020	December 1, 2020
<u>SERV 2.2</u>	<p>Excess Flow Valve or Manual Shut-off Valve</p> <p>Appendix B – (B-4) 2 Inch IPS higher capacity and (B-6) Reducer Coupling with EFV for Meter Upgrades-</p>	October 1, 2020	December 1, 2020
<u>STLP 2.2</u>	<p>Design Pressure</p> <p>Section 4.4 Design Factor</p> <p>4.4.1 Table 2 Class Location and Design Factor</p>	October 1, 2020	October 1, 2020
<u>TURN 2.4</u>	<p>Lighting Appliances and Check Appliance Safety</p> <p>Section 6.0 Lighting Appliances – Furnaces</p> <p>Subsection 6.4 Operational Check – corrected numbering sequence.</p>	October 1, 2020	October 1, 2020

UNCONTROLLED IF PRINTED

UPRT 0	Table of Contents Remove UPRT 2 from the electronic version	October 1, 2020	October 1, 2020
UPRT 1	Requirements Reference Documents: Removed UPRT 2	October 1, 2020	October 1, 2020
UPRT 2	Removed	Removed	Removed
WELD 2.5	Visual Inspection Paragraph 4.5.2 corrected reference link to Paragraph 6.2.6	October 1, 2020	October 1, 2020

Document Rescission

SUMM - Change Summary, October 1, 2020.

UNCONTROLLED IF PRINTED

Variable "version" is not defined

CHANGE SUMMARY

October 1, 2020

Complete Change Summary			
Docu- ment	Change Summary	Previous Document Dated	Current Document Dated
ABND 1	<p>Requirements</p> <p>4.0 Pre-Abandonment Planning</p> <p>4.1. General topics to be considered in planning for abandonment:</p> <p>4.1.6 Does abandonment involve any pipeline that crosses a roadway?</p> <p>4.1.7 Does abandonment involve any pipeline that crosses over, under or through a commercially navigable waterway?</p> <p>4.1.8 Does abandonment involve an underground natural gas storage facility?</p>	April 1, 2020	October 1, 2020
ABND 2.1	<p>Abandonment of Gas Facilities</p> <p>4.0 Abandonment - General</p> <p>4.3 See the following resources when pipeline facilities may have or contain materials requiring special handling:</p> <p>4.3.1 MAIN 2.5 Pipe Coating and Gasket Removal.</p> <p>4.3.2 PCBH 1 PCB Handling</p>	April 1, 2020	October 1, 2020
Former ABND 2.08	Removed Mercury Containing Devices section from the O&M.	January 1, 2011	October 1, 2020
ACIG 1	<p>Requirements</p> <p>4.0 Sources of Ignition</p> <p>4.1 Smoking and Open Flames</p> <p>Added use of vaping devices as a prohibited activity.</p> <p>4.2 Added Mechanical Sparking to Electric Arcing.</p>	April 1, 2019	October 1, 2020
CORR 2.3	<p>Appendix I: Specific Coatings</p> <p>Tapecoat 20 should be kept clean and dry prior to application.</p>	October 1, 2019	October 1, 2020
EMER 2.1	<p>Customer Care Center</p> <p>4.0 General</p> <p>4.3 The Customer Care Center department with gas operations providing oversight shall develop the actual script as to how CRS's communicate with a caller.</p> <p>5.0 Receiving Natural Gas Odor or Leak Call</p> <p>5.9 For outdoor odor or leak - smell, hear, or see</p> <p>5.9.1.5 Added "at a safe distance upwind of the leak"</p> <p>5.9.1.6 Added "If the conditions worsens, such as an ignition or explosion, call 911."</p> <p>9.0 Receiving Carbon Monoxide Call from General Public or AIC Customer</p> <p>9.3.1.2 added "Call 911 immediately after evacuating"</p>	January 1, 2018	October 1, 2020

UNCONTROLLED IF PRINTED

<p>Former EMER 2.01</p>	<p>Removed 6. Carbon Monoxide Call Removed 9.B.3 "Advise the customer to contact Poison Control Center at 1-800-222-1222. Poison Control will talk with the customer over the phone and may be able to provide advice on treating symptoms."</p>	<p>January 1, 2018</p>	<p>October 1, 2020</p>
<p><u>EMER 2.4.10</u></p>	<p>Gas Field Personnel - Over Pressure Changed Table 1 - High-Pressure Distribution & Transmission "Maximum Emergency Pressure (MEP) to: MAOP + 10% or 75% SMYS whichever is less</p>	<p>April 1, 2020</p>	<p>October 1, 2020</p>
<p><u>EMER 2.9</u></p>	<p>CNG Trailers 10.2 Additionally, shipping papers are required: Changed 10.2.3 to read "To be retained for 2 years by GTS" 10.3 HAZMAT Employees Added 10.3.3 GTS shall keep a record of current training of each HAZMAT employee, inclusive of the preceding 3 years, for as long as that employee is an AIC HAZMAT employee and for 90 days thereafter.</p>	<p>October 1, 2011</p>	<p>October 1, 2020</p>
<p><u>MAIN 2.6</u></p>	<p>Main Installation: Insertion Specified Supervising Engineer approval, rather than supervisory approval, is required for main insertion. 4.0 General 4.2 Main insertion through abandoned gas main should only be performed with Supervising Engineer approval.</p>	<p>April 1, 2019</p>	<p>October 1, 2020</p>
<p><u>METR 3.2</u></p>	<p>Regulator Sizing Appendix A -Regulators for New Installations @ 7"w.c. Delivery Pressure 1" x 1" Itron B42R or American 1813C with 1/4" orifice, Stock Code 62 06 493. Added Engineering only. Engineering must specify this regulator since it requires an orifice change. Stock coded regulator comes with 1/8" x 3/16" orifice that has to be replaced with 1/4" orifice for the listed capacities.</p>	<p>January 1, 2018</p>	<p>October 1, 2020</p>
<p><u>METR 4</u></p>	<p>Forms and Reference Materials Reference Materials Added Appendix A - Meter Test Schedule & Retention Requirements. Provides in a table format all of the testing, scheduling, allowable tolerances, file location, retention period and prover certification required to be performed at AIC.</p>	<p>April 1, 2019</p>	<p>October 1, 2020</p>
<p><u>OQAL 2.02</u></p>	<p>Covered Task AOC's OQ Department has prepared a task specific AOC's for 118 Covered Task. The purpose of this document is to provide field personnel with the information needed when questioned by an ICC inspector.</p>	<p>New</p>	<p>October 1, 2020</p>
<p><u>POLY 2.3</u></p>	<p>Installation 10.0 Weak Link Added, NOTE: Using a larger pull plug is considered a weak link method.</p>	<p>New</p>	<p>October 1, 2020</p>
<p><u>POLY 2.4</u></p>	<p>Butt Fusion</p>	<p>April 1, 2019</p>	<p>October 1, 2020</p>

UNCONTROLLED IF PRINTED

	<p>8.0 Joint Assembly</p> <p>8.1 Inspect the pipe ends</p> <p>8.1.1 Pipe ends shall be clean and free of contaminates prior to placing in the butt fusion machine. Clean with water, alcohol solution or clean rag/towel.</p>		
REGS 2.2	<p>Bypass Operations</p> <p>Added, Caution Note - If bypass operator needs to leave the site, contact supervisor for replacement and remain at the site until replacement arrives.</p>	January 1, 2018	October 1, 2020
REPR 1	<p>Requirements</p> <p>5.0 Leak Repairs</p> <p>5.7 Leaks in threaded connections can be repaired by methods including:</p> <p>5.7.1 Tightening the fittings</p> <p>5.7.2 Disassembling and applying thread sealer or Teflon thread tape and reassembling (See STLP 1), OR</p> <p>5.7.3 Replacing the fittings</p> <p>5.8 Leaks in flange connections can be repaired by:</p> <p>5.8.1 Tightening the flange bolts, AND/OR</p> <p>5.8.2 Replacing the flange gasket.</p>	October 1, 2019	October 1, 2020
TAPS 1	<p>Requirements</p> <p>4.0 General</p> <p>4.7 When greater than a 12 inch diameter hydraulic stopping equipment is utilized it can be left in operation unattended overnight when:</p> <p>4.7.1 The pipe has not been cut, OR</p> <p>4.7.2 The pipe has been capped utilizing approved welding procedures, see WELD 2.4,</p>	October 1, 2019	October 1, 2020
WELD 1	<p>Requirements</p> <p>11.0 Repair or Removal of Defects</p> <p>11.5 Weld repair on pipe that is not fixed in position (i.e., on skids or jack stands) is allowed by cutting out 1 inch on each side of the weld and reposition pipe back together. Then re-weld using the original weld procedure.</p>	April 1, 2020	October 1, 2020
WELD 2.3	<p>Construction of Pipelines</p> <p>9.0 Welding Requirements</p> <p>Added: 9.7 Socket Weld Joining</p> <p>9.7.1 Socket weld fitting shall initially be fully seated on the clean pipe end.</p> <p>9.7.2 The end of the fitting shall be marked on the pipe.</p> <p>9.7.3 The fitting shall be moved 1/16" to 1/8" away from the mark or an approved spacer ring installed between the mark and the fitting.</p> <p>9.7.4 Socket weld fitting shall not be bottomed out when welding.</p>	October 1, 2019	October 1, 2020
WELD 2.5	<p>Visual Inspection</p> <p>4.0 Inspection Requirements</p> <p>4.5 Pipe Butt Welds</p>	January 1, 2012	October 1, 2020

UNCONTROLLED IF PRINTED

	<p>4.5.5 Cap Pass</p> <p>Added: 5 e. Visible porosity (pinholes) is not allowed. Porosity shall be removed by grinding. If the grinding reduces the cap below the pipe surface, the weld will be repaired following weld repair requirements:</p> <ul style="list-style-type: none"> • 200 - 500 °F preheat. • Weld length at minimum 2 inches. • Steel punches or peening the hole shut is not permitted for permanent repair. 		
<p>WWBG 2.1</p>	<p>Requirements</p> <p>6.0 Safe Zone</p> <p>6.2 Gas Field Personnel Shall:</p> <p>Added 2. When responding to a 2-inch and smaller cut main or service line operating at 60 psig or less and life and property are at risk or it is not possible or practical to control blowing gas from a gas free atmosphere, then:</p> <p>2a. A minimum of 2 gas field personnel wearing Level 1 PPE can approach a 2-inch and smaller cut main or service line using the following procedures:</p> <ul style="list-style-type: none"> • Approach from an upwind position with a fire extinguisher readily available and discharged tested. • Monitor the gas-in-air concentration to ensure the atmosphere remains less than 60% LEL. • Use an above grade squeeze tool per POLY 2.2 	<p>April 1, 2020</p>	<p>October 1, 2020</p>

Document Rescission

SUMM - Change Summary, July 1, 2020.

UNCONTROLLED IF PRINTED

UNCONTROLLED IF PRINTED

Major Changes in this Update	
<p>Changes in the following sections, EMER. INCD, INVE and LEAK are a result of comments by Expert Emergency Response Consultant (EERC) and discussions between the EERC consultant and the SMR teams. EERC was asked to review AIC's O&M and make recommendations for improving AIC's emergency response procedures to ensure the safety of the general public, customers, emergency responders, AIC's employees and property are being adequately addressed.</p>	
<p>EMER 2.02</p>	<p style="text-align: center;">Dispatch Center</p> <p style="text-align: center;">1. Dispatching Gas Field Personnel to an Emergency Call</p> <p>1. C.: Revised - - If gas field personnel, emergency responder and Gas Supervisor are unavailable to respond to the call, the dispatcher shall contact the appropriate local police and/or fire department to request assistance.</p> <p style="text-align: center;">3. Cold Weather Electrical Outage and Restoring Electric Service</p> <p>3. A. (4) (a) & (b): Correction - 500+ customers on a gas system identified as High risk and 300+ customers is identified as Moderate risk.</p> <p style="text-align: center;"><i>Risk level had to be switched.</i></p>
<p>EMER 2.03</p>	<p>Emergency Responder - The following changes were made based on discussions between the EERC representative and EMER Investigation SMR team.</p> <p style="text-align: center;">2. Upon Arrival (Inside Leak)</p> <p style="text-align: center;">Added following instructions:</p> <p>2. C. (1): If volt stick alarms when riser is checked proceed with the emergency responders' procedures <u>but do not shut off meter valve.</u></p> <p>2. F.: Revised - If there is any movement of the test hand, shut the meter valve or customer valve off.</p> <p style="text-align: center;">2. J. Evacuate the structure</p> <p>2. J. (1): New - Multi-family structure or a structure containing a large number of people, such as school, hospital, nursing home, manufacturing or commercial business, responder should contact or have dispatch contact fire department to request assistance with evacuation.</p> <p style="text-align: center;">4. Upon Arrival (Cut Main or Service)</p> <p>4. B.: New - Avoid parking over manholes as they may be within the gas leak migration pattern and could possibly be venting.</p> <p>4. C.: New - Avoid parking over main valves in the event that they are required for make safe actions.</p>

These added to be consistent with Upon Arrival (Outside Leak) instructions that were added in October 1, 2019 Update at the recommendation from EERC.

**EMER
2.04**

Gas Field Personnel - The following changes were made based on discussions between the EERC representative and EMER Investigation SMR team.

2. Inside Odor Compliant - Hazardous Condition

Lowered the threshold to 10% LEL to be consistent with LEAK 2.01 Indoor Leak Investigation.

Inside Odor Complaint - Hazardous Condition

2. A. Evacuating the structure....

2. A.: Revised - Instruct them not to touch anything, operate any electrical switches or use any electronic devices as they exit.

5. Gas in a Sewer - Hazardous Condition

5. D. Check adjacent structures for gas migration

5. D. (1): Lowered the hazardous condition threshold to 10% LEL when entering a structure. When evacuating the people have them move to a safe distance.

8. Explosion and /or Fire Near Gas Pipeline Facilities

8. C.: Shall replaces should. Gas field personnel shall notify a Gas Supervisor.

8. F.: Revised - Gas field personnel should also attempt to make contact with the Fire Chief or fireman in charge at the scene and communicate AIC's concerns and pertinent information about AIC's facilities.

10. Low Pressure Situation

10. C. Low pressure may result from

10. C. (6): Revised - Unintentional shutting off or restricting gas supply to an area.

10. E. When low pressure situation is discovered, the following steps should be followed:

10. E. (3): Added lock meter valve for those customers affected.

10. E. (7): New - Identify critical customers such as hospitals, nursing homes, schools or other public facilities that may need additional support or temporary supply during an outage.

11. Over Pressure Situation

11. H.: Revised - Use valves to throttle or shut down the feed to the system until the pressure is within the normal operating range. Valves shall be constantly monitored until high pressure situation is corrected.

11. L.: New - If the MEP has been exceeded, consideration should be made to at least communicate with the local fire department and/or police in case their assistance may be needed.

12. Loss and Restoration of Service

	<p>12. D.: New - Identify critical customers such as hospitals, nursing homes, schools or other public facilities that may need additional support or temporary supply during an outage.</p> <p>12. M.: Turn-off requirement for an outage</p> <p>12. M.(1): Revised - Turn-off the meter valve or curb valve for each affected customer: The meter valve is required to be locked</p> <p><i>Requires locking the meter valve to ensure customer does not attempt to re-light during the outage,</i></p> <p>12. N.: For cases where the turn-off cannot be completed without forcible entry:</p> <p>12. N. (5) (a): New - Leave a door hanger or notice notifying the customer that due to an emergency, AIC had to make a forcible entry.</p> <p>12. N. (5) (b): New - Door hanger or notice shall contain AIC's contact number 800-755-5000.</p> <p>12. N. (6): Revised - Document damage to the premise from the forced entry along with the names of those present.</p> <p><i>Note: If police officer witnessed the forced entry, record the officer's name and badge number.</i></p> <p>12. T.: Turn-on requirements for an outage:</p> <p>Removed sentence if service is not restored the meter valve shall be left off and locked.</p> <p><i>Meter valve is locked during the turn-off process.</i></p>
<p>EMER 2.05</p>	<p>Natural Disasters or Civil Disobedience - The following changes were made based on discussions between the EERC representative and EMER Investigation SMR team.</p> <p>2. Natural Disasters</p> <p>2. D.: If AIC facilities are damaged or in danger of failing. Communicate with the appropriate fire department the potential impact on AIC's facilities.</p> <p>2. I.: In devastated areas where there is uncontrolled over pressure of release of large amounts of gas. The local fire department should be notified of the situation and the potential impact.</p> <p>3. Floods</p> <p>3. A. (3): Prior to flooding: Individual services should be shut off and locked with priority given to inside services.</p> <p>3. A. (5): If water covers pilots on interior appliances, the service should be shut off and a Warning Tag issued.</p> <p>4. Civil Disobedience</p> <p>4. B. (5): If violence or any threat to AIC personnel's safety persists, personnel and surveillance patrols should be withdrawn from the area. Law enforcement and Ameren Security shall be notified.</p>

<p>EMER 2.08</p>	<p>Investigation of Failures The following changes were made based on discussions between the EERC representative and EMER Investigation SMR team.</p> <p style="text-align: center;">2. Analysis of Failed or Defective Materials</p> <p>2. B.: Added "interim information communicated to operations" so decisions can be made concerning the need to take corrective action.</p>
<p><u>INCD 1</u></p>	<p>Incident Report Requirements: Part 191 now requires a release of gas from a natural gas underground storage be included in the reporting requirements. IDNR requires an incident resulting from release of stored gas from the downhole portion of a storage well must be reported. Therefore, gas underground storage facilities and Superintendent/Supervisor Gas Storage has been added throughout INCD 1. The incident reporting matrix has been updated. In addition, INCD 1 was reviewed by a representative of Expert Emergency Response Consultant (EERC). Some revisions were made in INCD 1 based on discussions between the EERC representative and John Bozarth. The following are the major additions to the Incident Reporting requirements:</p> <p style="text-align: center;">1. Objective</p> <p style="text-align: center;">1. B.: Added - underground natural to gas storage facilities.</p> <p style="text-align: center;">1. C.: Added - Supervisor Gas Storage</p> <p>1. C. (1): New - Gas personnel or storage field personnel shall promptly verbally notify Gas Supervisor or Supervisor Gas Storage when there is a potentially reportable incident.</p> <p style="text-align: center;">2. Natural Gas Incident</p> <p>2. A.: Added - including an underground natural gas storage facility including the downhole portion of an underground natural gas storage facility</p> <p style="text-align: center;">2. A. (2): Clarified - in-patient hospitalization means at least one overnight stay</p> <p>2. A. (5): New - Unintentional estimated gas loss from the downhole portion of an underground natural gas storage facility of 500,000 cubic feet or more that occurs within 1/8 mile of a dwelling used as a residence, place of business or place of public assembly.</p> <p style="text-align: center;">3. Potential Significant Event</p> <p style="text-align: center;">3. B.: Added - including an underground natural gas storage facility as an AIC facility where a release of gas shall be reported to Gas Compliance.</p> <p style="text-align: center;">4. Courtesy Notification</p> <p>4. A. (5): New item which may warrant a courtesy notification - Odorizer failure resulting in either over odorization or under odorization.</p> <p style="text-align: center;">6. Reporting</p> <p>6. A.: Added - Gas Superintendent and Superintendent/Supervisor Gas Storage to those who shall contact Gas Compliance within 1 hour following confirmed discovery</p>

	<p>6. A. Note: Added - Confirmed discovery - See GLOS</p> <p>6. B.: Added- Illinois Department of Natural Resources (IDNR) as another agency that Compliance must notify. 8. A. Table - Report within 1 hour of confirmed discovery:</p> <p>13.; New - Unintentional estimated gas loss from the downhole portion of an underground natural gas storage facility of 500,000 cubic feet or more that occurs within 1/8 mile of a dwelling used as a residence, place of business or place of public assembly.</p> <p>8. B. Table of agencies that Gas Compliance contact:</p> <p>Added - IDNR when the incident is the result of stored natural gas from downhole portion of gas storage facility.</p>
<p>INVE 1</p>	<p>Investigation of Incidents: Requirements - Following changes are a result of the review by Expert Emergency Response Consultant and discussions John Bozarth. The major changes are as follows:</p> <p>1. Objective - Added confidential before investigation</p> <p>2. General</p> <p>2. D. (3); New - Where gas is determined not to be a contributing factor consult with Ameren Claims to determine if any evidence needs to be retained in Ameren Illinois custody.</p> <p>2. F.: Revised - Gas facilities that may have failed or may have been impacted must be preserved and kept in a secured location until Corporate Claims specifies a location where facilities can be analyzed.</p> <p>3. NTSB Investigation of Incident</p> <p><i>This is a new section that has been added to provide instructions and guidance to gas personnel in the event NTSB launches an investigation of an incident.</i></p>
<p>INVE 2.01</p>	<p>Incident Investigation</p> <p>2. Investigation Documentation</p> <p>2. C.: New - Once Ameren Claims personnel are on the scene, they will normally be taking the photos and documenting the investigation. Only one designated person should be taking photos and documenting the investigation in order to eliminate the possibility of conflicting information if situation becomes a legal issue.</p> <p>2. I.: Added - Where applicable, include witness' agency, title and email address.</p> <p>2. J.: Added - (avoid including any speculation)</p> <p>2. K.: Word change - accessed replaces forfeited.</p> <p>Deleted reference to the 35 mm camera being used to supplement the investigation.</p> <p><i>Gas field personnel will have to provide access to photos taken of an incident with their cell phone if the photos are needed as evidence.</i></p>

	<p>2. L.: Revised - Pay special attention to areas which may include:</p> <p>2. L (9): New - Consider any other areas of interest such as sewer traps, sewer clean-outs, etc</p> <p>2. N.: Added - Interview the witnesses by asking the following questions. If witnesses are going to be available, consider waiting until Ameren Claims personnel arrive.</p> <p>2. N. (1): Revised - Describe what happened, including what was observed.</p> <p style="text-align: center;">3. Investigation of AIC Facilities</p> <p style="text-align: center;">3. D.: Check the odorant level of the gas with an odorator.</p> <p>3. D. (1): Revised - In addition to the reading performed by a qualified AIC gas personnel, request that a public official, (i.e. Police or Fire Department personnel), check the readily detectable odorant level.</p> <p style="text-align: center;">5. Analysis of the Incident</p> <p>5. D.: Revised - The report shall also contain supporting documentation as well as establishing the apparent cause of the incident.</p> <p style="text-align: center;">6. Preservation of Evidence</p> <p>6. A.: Addition - Information collected through the investigation and analysis of the gas related incident should be preserved as prescribed by AIC Gas Compliance and Ameren Legal/Claims.</p>
<p>INVE 2.02</p>	<p style="text-align: center;">Investigation of Fires</p> <p style="text-align: center;">1. General</p> <p>1. A.: Addition - This section provides instructions for investigation of the apparent cause of a gas related fire, ignition, or explosion.</p> <p style="text-align: center;">2. Fire, Ignition or Explosion Investigation</p> <p>2. A.: Addition - AIC's first and foremost concern is to respond to the scene promptly, deal with any hazardous conditions that may be present, cooperate in any investigation and to render any assistance to emergency personnel that may be requested.</p> <p style="text-align: center;">5. Communication with Fire Department</p> <p>5. A.: Revised - Once determined that natural gas is suspected or confirmed to have been involved in the incident, gas field personnel should limit discussions with the Fire Departments to a designated AIC individual while continuing to cooperate to make the scene safe for the fire department and general public.</p> <p>5. B.: Revised - Any requests for investigation results should be directed to Ameren Legal/Claims.</p> <p>5. D.: Addition - The content of the investigation should remain confidential and should not be released to anyone external to Ameren without approval from Ameren Legal/Claims.</p>
<p>LEAK 2.01</p>	<p>Indoor Leak Investigation: The major change is lower the hazardous condition threshold to 10% LEL. Research provided by EERC indicated 10% LEL is becoming the industry standard. If 10% LEL is registered at the door, there</p>

is going to be higher concentrations somewhere in the structure which could be in the explosive range. Other major changes are to provide additional protection to the public and workers.

1. D.: Hazardous conditions downgrade to 10% LEL from 30%.

3. Approaching Structure

3. B.: Revised - Before touching the gas meter, check the riser, meter and customer piping with volt stick. If voltage stick alarms refer to **METR 2.20 2.**

A. AC Voltage on Meter Set.

3. D.: New - Before entering ensure all personnel electronic devices, such as cell phones, are powered off and all intrinsically safe equipment, such as CGI and flashlight, is powered on.

Caution: The flashlight on the volt stick is not intrinsically safe and should be left off while inside.

4. Customer is Home

4. A. Upon entering the structure;

4. A. (3): New - Advise customer not to operate any switches or use any electronic devices, such as cell phone, while the investigation is being conducted.

4. A. (4): New - Continue to monitor the atmosphere while moving to the area where the odor is suspected.

4. C.: Revised - An indoor concentration at the entrance of the structure or throughout the structure of **10% LEL (0.5% Gas-In-Air)** or greater is an immediate hazard, and the structure should be evacuated and **EMER 2.04 2.** Inside Odor Compliant - Hazardous Condition implemented.

4. D. Carbon monoxide reading of 100 PPM or greater

4. D. (1): (b) New - Call 911, the fire department may assist with the evacuation and ventilation.

4. D. (2): Added - Issue a Warning Tag and advise customer to contact a qualified professional to have the system checked.

5. Customer Not Home or Can't Get Into Structure

5. A. Revised - Before touching the gas meter, check the riser, meter and customer piping with volt stick. If voltage stick alarms refer to **METR 2.20 2.**

A. AC Voltage on Meter Set.

6. Leaks on Customer Facilities

6. A. (2): Added - If simple repair cannot be made notify customer of the gas leak and advise customer they should have a qualified professional make the repairs.

LEAK 2.02

Outdoor Leak Investigation - There are a few proposed additions that EERC felt would improve these procedures.

4 Above Grade Gas Facilities

4. A. (6): New - Customer owned natural gas facilities such as; standby generators, pool heaters, barbecue, etc

	<p style="text-align: center;">7. Hazardous Conditions</p> <p style="text-align: center;">7. A. (4): New - Suspected damaged gas facility.</p> <p style="text-align: center;"><i>Added to the list of conditions that should be considered when determining if there is a hazardous condition.</i></p> <p>7. C.; Revised - If necessary, request additional resources to establish and maintain a safety zone to prevent unauthorized personnel from entering until repairs are made or the situation made safe.</p> <p style="text-align: center;">8. Leaks on Customer Owned Facilities</p> <p>8. A. (2): Revised - If simple repairs cannot be made notify customer of the gas leak and advise customer they should have a qualified professional make the repairs. Consistent language with LEAK 2.01.</p>
<p>LEAK 2.04</p>	<p>Leak Classification and Surveillance - EERC felt leak classification criteria needed to be simplified and consistent with the industry's position that any gas reading within 5 feet of a foundation would be classified a Grade 1 regardless of the volume. EERC didn't have any objections to the 2% LEL or less outside the 5 feet from the foundation. As for foreign gas. EERC felt that AIC should contact the appropriate authority when foreign gas was detected.</p> <p style="text-align: center;">7. Foreign Gas</p> <p style="text-align: center;">7. A. (5): Added - Natural gas from another supplier or utility.</p> <p>7. C.: New - Contact Dispatch to notify the appropriate authority such as; fire department, municipal sewer department or pipeline company.</p> <p style="text-align: center;">8. Leak Surveillance, Repair and Recheck Schedule</p> <p>8. A. (1): Revised - Class 1 leak requires immediate repair or continuous action until the hazardous condition no longer exists. Immediate temporary measures, such as venting may be employed to protect the public and property; however, the leak remains a Class 1 leak until approved repairs are made.</p> <p style="text-align: center;">10. Repaired Leak Recheck</p> <p style="text-align: center;">10. A. Below Grade</p> <p>10. A. (3) (b): Revised - If residual gas readings are detected within zero (0) to five (5) feet from the foundation wall:</p> <ul style="list-style-type: none"> • Daily readings shall be performed until there is a 0% LEL gas reading. • If daily readings show increased levels of gas, a check shall be made for gas migration inside the structure. <p style="text-align: center;"><i>Clarifies when checking inside for migration is required.</i></p>
	<p style="text-align: center;">The following major changes are based on proposals from SMR Teams</p>
<p>ABND 2.01</p>	<p style="text-align: center;">Abandonment of Gas Facilities</p> <p style="text-align: center;">2. Project Specific Procedures - New section</p>

A. Gas Tech Engineering or Gas Storage Engineer shall prepare written project specific procedures for abandoning facilities on projects that meet the following criteria:

- (1) Transmission facilities, or
- (2). High pressure distribution facilities with MAOP over 100 psig, or
- (3) Joint abandonment of transmission lines or high pressure distribution mains with MAOP over 100 psig with connected services.

Note: If the abandonment is a result of an emergency project or maintenance project, Division Gas Supervisor or Engineer should ensure the abandonment job packet is submitted to GTE.

B. Engineering personnel (i.e. Distribution Design Specialist or Engineer, Division Gas Engineer) shall prepare written project specific procedures for abandoning facilities on projects that meet the following criteria:

- (1) Distribution facilities with MAOP of 61 psig to an including 100 psig, and
- (2) Joint abandonment of distribution main with 10 or more connected services.

C. Procedures will include, at a minimum

- (1) Operational Checklist, refer to PRES 2.03
- (2) Written procedures along with maps should address such issues as:
- (3) Purge plan in accordance with PURG 2.01 - Purging Methods.

D. A pre-job meeting should be held to review the written procedures.

Changes were made to clarify when engineering prepared abandonment plans are required and to provide more guidance on should be included in those plans. Changes were also made in PURG 2.01 for consistency in expectations.

4. Services

4. A. (10): Revised - Service lines that are two (2) inches or larger in nominal diameter shall be purged as main when the service line is:

- (a) 500 feet or longer and operating at 100 psig or less, or
- (b) 100 feet or longer and operating above 100 psig.
- (c) See **PURG 2.01.5. Purging of Gas with Air During Abandonment.**

Expanded to be consistent with PURG 2.01 language to avoid confusions.

**METR
2.20**

Meter Header Inspection

Has been modified to one list of items to be checked whenever there is any work being performed on a meter set. Eliminated the distinction between if a meter set is disassembled or not. Thereby eliminating duplicate lists.

4. Inspection of a Meter Set

4. B. The following items should be checked:

Simplified and clarified the listing of items such as:

	<p style="text-align: center;">4. B. (6) Meter partially buried or setting on ground</p> <p style="text-align: center;">4. B. (7) Regulator relief not freely vented to the atmosphere</p> <p>4. B. (11) Change the Note to a Warning: If the regulator may contain mercury, do not replace, remove or disturb without specific instructions from Ameren Environmental. See ABND 2.08.</p> <p>4. E.: Revised - Deficiencies should be corrected immediately or documented in ClickMobile and reported to the Gas Supervisor for follow-up action.</p> <p>4. F.: If meter set is being disassembled, the following corrective action should be taken in addition to the inspection:</p>
<p>POLY 2.02</p>	<p style="text-align: center;">Squeeze Off</p> <p style="text-align: center;"><i>Procedures have been revised to meet Performance Pipe's recommended practice contained in their Technical Note PP-801-TN. The squeeze rate and release rate is based on the recommendation in ASTM 1041.</i></p> <p style="text-align: center;">2. Operation</p> <p>2. B. (1): New - Do not squeeze if there is a scratch deeper than 10% of wall thickness.</p> <p>2. G. (2): Revised - If air temperatures are near freezing or lower, closure should be slowed to approximately 2 minutes per inch of pipe's designated diameter.</p> <p>2. J.: Revised - When placing pipe back in service, slowly release the squeeze in a controlled rate at approximately 2 minutes per inch of pipe's designated diameter to allow the pipe to relax.</p>
<p>POLY 2.05</p>	<p style="text-align: center;">Electrofusion</p> <p style="text-align: center;">6. Pipe Preparation</p> <p>6. A. (4) (b): Added back in the insertion depth of 2-1/4" the Central Plastic 2 inch elbow.</p> <p>6. A. (5): Added back into the cleaning instructions. "wiping in one direction and discarding wipe or towel"</p> <p style="text-align: center;"><i>These 2 items were inadvertently left out when format of POLY 2.05 was changed to text vs chart in the October 1, 2019 Update. Wiping in one directions and discarding towel is in Central Plastic's electrofusion training instructions.</i></p>
<p>PURG 2.01</p>	<p style="text-align: center;">Purging Methods</p> <p style="text-align: center;">1. General</p> <p style="text-align: center;">1. A.: Reformatted, expanded -</p> <p>A. This section outlines the procedures to be followed when purging:</p> <ul style="list-style-type: none"> (1) Transmission lines. (2) High pressure distribution mains. (3) Distribution mains

- (4) Service lines 2 inches and larger and 500 feet or longer.
 - (5) Service lines 2 inches and larger, 100 feet or longer and operating above 100 psig.
- B. Gas Engineering, Gas Tech Engineering (GTE) or Gas Storage Engineer will provide detailed purging plans, prior to blow-down or purging operations on: (Refer to tables below)
- (1) Transmission lines 100 feet and longer.
 - (2) High pressure distribution mains 100 feet and longer.
 - (3) Service lines 2 inch and larger, and
 - (a) 100 feet or longer in length, and
 - (b) Operating at more than 100 psig.
 - (4) Projects utilizing an air mover.

Reformatted and revised to be consistent with ABND 2.01 and tables in PURG 2.01.

5. Purging of Gas with Air During Abandonment

5. F.: Word changes - The 2 tables

Service Line Smaller than 2 inch and less than 500 feet in length
and

Service Line Smaller than 2 inch but 500 feet or longer in length

Needed corrected to be consistent with ABND 2.01.

5. F. Tables: Added the following 2 items that require a Purge Plan in the Operating Pressure 100 PSIG or Less table:

Air Mover utilized to purge

Joint Abandonment of Distribution Main and Services (**ABND 2.01** 2. B.)

Added the following 2 items that require a Purge Plan in the Operating Pressure Greater than 100 PSIG table:

Air Mover utilized to purge

Joint Abandonment of Transmission Line or HP Distribution Main and Services (**ABND 2.01** 2. A.)

Joint abandonment is addressed in ABND 2.01 and the air mover is addressed in PURG 2.01 8. They were added to the table to avoid confusion as to expectations.

**SERV
2.02**

Excess Flow Valves or Manual Shut-Off Valves

8. EFV Sizing

8. E.: Added - 2 inch IPS

8. F.: Reformatted and Revised -

8. F. When selecting an EFV the following should be taken into consideration:

	<p>(1) Lowest anticipated inlet pressure - cannot drop below 10 psig.</p> <p>(2) Service line size (i.e. 1" CTS requires 1" EFV).</p> <p>(3) Length of service line must be less than maximum length in the tables below.</p> <p>(4) Maximum capacity of the meter being specified or could be specified shall not exceed maximum design flow in tables below.</p> <p style="text-align: center;">8. G. EFV Sizing Tables</p> <p style="text-align: center;">8. G. (4): Added new 2 inch UMAC Series 5500 EFV.</p> <p style="text-align: center;">8. G. (2) & (3): Update Maximum Flow and Maximum Length values.</p> <p style="text-align: center;"><i>Ran all of our UMAC EFVs through UMAC's updated sizing calculator and updated the tables for the 1 inch and 2 inch EFVs</i></p> <p style="text-align: center;">8. G. (6): Correct stock code, 39 22 635, for the 1" x 1/2" CTS reducer coupling with EFV.</p>
--	---

Complete Change Summary (current documents dated April 1, 2020 unless otherwise noted)		
Document	Change Summary	Previous Document Dated
ABND 0	<p style="text-align: center;">Table of Contents</p> <p style="text-align: center;">ABND 2.01: insert new 2. Project Specific Procedures</p> <p style="text-align: center;">Removed Joint Abandonment of Transmission Lines or Distribution Mains and Services</p> <p style="text-align: center;">ABND 4: Removed Forms section. Purge Stamp had been moved to PURG 4</p>	April 1, 2019
ABND 2.01	<p style="text-align: center;">Abandonment of Gas Facilities</p> <p style="text-align: center;">2. Project Specific Procedures - New section</p> <p>A. Gas Tech Engineering or Gas Storage Engineer shall prepare written project specific procedures for abandoning facilities on projects that meet the following criteria:</p> <p style="text-align: center;">(1) Transmission facilities, or</p> <p style="text-align: center;">(2). High pressure distribution facilities with MAOP over 100 psig, or</p> <p>(3) Joint abandonment of transmission lines or high pressure distribution mains with MAOP over 100 psig with connected services.</p> <p style="text-align: center;"><i>Note: If the abandonment is a result of an emergency project or maintenance project, Division Gas Supervisor or Engineer should ensure the abandonment job packet is submitted to GTE.</i></p> <p>B. Engineering personnel (i.e. Distribution Design Specialist or Engineer, Division Gas Engineer) shall prepare written project specific procedures for abandoning facilities on projects that meet the following criteria:</p> <p style="text-align: center;">(1) Distribution facilities with MAOP of 61 psig to an including 100 psig, and</p> <p style="text-align: center;">(2) Joint abandonment of distribution main with 10 or more connected services.</p>	October 15, 2018

UNCONTROLLED IF PRINTED

	<p>C. Procedures will include, at a minimum</p> <p>(1) Operational Checklist, refer to PRES 2.03</p> <p>(2) Written procedures along with maps should address such issues as:</p> <p>(3) Purge plan in accordance with PURG 2.01 - Purging Methods.</p> <p>D. A pre-job meeting should be held to review the written procedures.</p> <p><i>Changes were made to clarify when engineering prepared abandonment plans are required and to provide more guidance on should be included in those plans. Changes were also made in PURG 2.01 for consistency in expectations.</i></p> <p>3. Transmission Line and Distribution Mains</p> <p>3. A. (1): Remove the reference to PRES 2.03.2</p> <p>4. Services</p> <p>4. A. (10): Revised - Service lines that are two (2) inches or larger in nominal diameter shall be purged as main when the service line is:</p> <p>(a) 500 feet or longer and operating at 100 psig or less, or</p> <p>(b) 100 feet or longer and operating above 100 psig.</p> <p>(c) See PURG 2.01.5. Purging of Gas with Air During Abandonment.</p> <p><i>Expanded to be consistent with PURG 2.01 language to avoid confusions.</i></p>	
<p>ABND 4</p>	<p>Forms and Reference Materials</p> <p>Removed Forms section. Purge Stamp had been moved to PURG 4</p>	<p>April 1, 2019</p>
<p>CORR 2.02</p>	<p>Anode Requirements</p> <p>5. Anode Bank Installation</p> <p>5. H.; Revised - Provide sufficient information, sketches and measurements for recording anode bank on AIC's electronic mapping system.</p> <p><i>Provides information needed for posting in electronic mapping system.</i></p> <p>5. I.: Added a word - test</p> <p>5. I. (1): Updated - Attach a # 8 test lead to the main and terminate the other end in test station.</p> <p>5. I. (2): Added - Bring the # 8 collector wire into the test station.</p> <p>5. I. (5): Deleted - (open bond and use anode cable for ground)</p> <p><i>Corrosion Control updated the instructions.</i></p>	<p>Janu- ary 1, 2018</p>
<p>CORR 2.12</p>	<p>Tapecoat TC Color Coat</p> <p>2. Application</p> <p>Removed references to Tapecoat TC Putty since it is no longer approved or stocked at AIC.</p>	<p>Octo- ber 1, 2019</p>
<p>CORR 2.23</p>	<p>Clearing Shorted Pipelines</p> <p>3. Preformed FRP Spacers - Type 120 - Stocked</p> <p>3. B. Installation</p>	<p>Octo- ber 15, 2018</p>

	<p>3. B. (2): Pipe support for above grade piping operating at over 60 psig and larger than four (4) inch diameter install FRP insulator between pipe support(s) and the pipe as follows:</p> <p>(a) The FRP should be cut to the approximate width of the saddle.</p> <p>(b) Coat the FRP with Protal, CORR 2.03 4., ensuring 100% coverage prior to being adhere to the pipe.</p> <p>(c) Adhere and press the FRP spacer against the pipe.</p> <p>(d) Wipe off excess Protal and smooth out around the edges of the FRP to create a clean transition.</p> <p>(e) Install pipe support under the FRP before the Protal cures.</p> <p><i>Note: The FRP may be coated or painted with any approved method in CORR 2.03.</i></p> <p><i>Reformatted and added instructional bullet points.</i></p>	
CORR 3.14	<p>Test Lead Wire Attachment</p> <p>1. E.: Removed the restriction of not attaching wire within 2 inches of longitudinal seam.</p>	October 1, 2019
	<p><i>The following CORR standards were all revised to reference attaching wire in accordance with CORR 3.14 Test Lead Wire Attachment: Each of the standards contained duplicate language regarding attaching the wire. Future changes in CORR 3.14 will apply to these standards.</i></p> <p>1. Eliminated the restriction of not attaching wire within 2 inches of a longitudinal seam and</p> <p>2. Allow a welded 5/16" steel bolt to be to attach wire on steel pipe with MAOP of 100 psig or less.</p>	
CORR 3.01	Anode Installation - Direct Connection	July 1, 2014
CORR 3.02	Anode Test Station	October 1, 2018
CORR 3.03	Parallel Anode Bank	July 1, 2014
CORR 3.04	Perpendicular Anode Bank	July 1, 2014
CORR 3.06	Anode Installation - Isolated Steel Service Line	July 1, 2014
CORR 3.07	Single Test Lead - Flush To Grade Test Station	July 1, 2014

CORR 3.08	Single Test Lead - Above Grade Test Station	July 1, 2014
CORR 3.09	Foreign Pipeline Crossing Test Station	July 1, 2014
CORR 3.10	Inline Insulator - Above Grade Test Station	July 1, 2014
CORR 3.11	Inline Insulator - Flush to Grade Test Station	July 1, 2014
CORR 3.12	Insulated Valve - Underground	July 1, 2014
CORR 3.13	Flange Fink Test Station	July 1, 2014
CORR 3.15	Rectifier Installation	July 1, 2014
EMER 0	<p>Table of Contents</p> <p>EMER 2.01 - added CO to CO Call Received from a Police or Fire Department</p> <p>CO Call Received from a Customer</p> <p>EMER 2.04 - Over Pressure Situation replaces High Pressure Situation</p>	October 1, 2019
EMER 1	<p>Requirements</p> <p>AIC replaces Ameren Illinois throughout the document.</p> <p>1. Objective</p> <p>1. B. Spelling correction: "defects"</p> <p>1. D. (9): Added "emergency responders" to those that safety measures are to protect.</p>	January 1, 2011
EMER 2.02	<p>Dispatch Center</p> <p>AIC replaces Ameren Illinois throughout the document</p> <p>1. Dispatching Gas Field Personnel to an Emergency Call</p> <p>1. C.: Revised - If gas field personnel, emergency responder and Gas Supervisor are unavailable to respond to the call, the dispatcher shall contact the appropriate local police and/or fire department to request assistance.</p> <p>1. G.: Word change -"maintained in" replaces "utilized in"</p>	October 1, 2019

UNCONTROLLED IF PRINTED

	<p>3. Cold Weather Electrical Outage and Restoring Electric Service</p> <p>3. A. (4) (a) & (b): Correction - 500+ customers on a gas system identified as High risk and 300+ customers is identified as Moderate risk.</p> <p><i>Risk level had to be switched.</i></p> <p>3. C. Updated contact list information for Gas Tech Support and Planning Group.</p>	
<p>EMER 2.03</p>	<p>Emergency Responder</p> <p>2. Upon Arrival (Inside Leak)</p> <p>2. C.: Revised - Before touching the gas meter, check the riser, meter and customer piping with volt stick. If voltage stick alarms refer to METR 2.20 2. A. - AC Voltage on Meter Set.</p> <p>Added following instructions:</p> <p>2. C. (1): If volt stick alarms when riser is checked proceed with the emergency responders' procedures <u>but do not shut off meter valve.</u></p> <p>2. F.: Revised - If there is any movement of the test hand, shut the meter valve or customer valve off.</p> <p>2. J. Evacuate the structure</p> <p>2. J. (1): New - Multi-family structure or a structure containing a large number of people, such as school, hospital, nursing home, manufacturing or commercial business, responder should contact or have dispatch contact fire department to request assistance with evacuation.</p> <p>3. Upon Arrival (Outside Leak)</p> <p>3. F.: Revised - Keep people a safe distance away from the leak and do not operate vehicles.</p> <p>4. Upon Arrival (Cut Main or Service)</p> <p>4. B.: New - Avoid parking over manholes as they may be within the gas leak migration pattern and could possibly be venting.</p> <p>4. C.: New - Avoid parking over main valves in the event that they are required for make safe actions. <i>These added to be consistent with Upon Arrival (Outside Leak) instructions</i></p>	<p>October 1, 2019</p>
<p>EMER 2.04</p>	<p>Gas Field Personnel</p> <p>AIC replaces Ameren Illinois throughout the document.</p> <p>2. Inside Odor Compliant - Hazardous Condition</p> <p>Lowered the threshold to 10% LEL to be consistent with LEAK 2.01 Indoor Leak Investigation.</p> <p>Inside Odor Complaint - Hazardous Condition</p> <p>2. A. Evacuating the structure....</p> <p>2. A.: Revised - Instruct them not to touch anything, operate any electrical switches or use any electronic devices as they exit.</p> <p>2. B.: Removed - if possible</p> <p>2. B. Shut off the gas from outside the structure.</p> <p>4. Major Leaks or Line Breaks</p> <p>4. B.: Removed duplicate language that is covered in 4. B. (2) and (3).</p>	<p>October 1, 2019</p>

5. Gas in a Sewer - Hazardous Condition

5. D. Check adjacent structures for gas migration

5. D. (1): Lowered the hazardous condition threshold to 10% LEL when entering a structure. When evacuating the people have them move to a safe distance.

8. Explosion and /or Fire Near Gas Pipeline Facilities

8. C.: Shall replaces should. Gas field personnel shall notify a Gas Supervisor.

8. F.: Revised - Gas field personnel should also attempt to make contact with the Fire Chief or fireman in charge at the scene and communicate AIC's concerns and pertinent information about AIC's facilities.

10. Low Pressure Situation

10. C. Low pressure may result from

10. C. (6): Revised - Unintentional shutting off or restricting gas supply to an area.

10. E. When low pressure situation is discovered, the following steps should be followed:

10. E. (3): Added - lock meter valve for those customers affected.

10. E. (7): New - Identify critical customers such as hospitals, nursing homes, schools or other public facilities that may need additional support or temporary supply during an outage.

11. Over Pressure Situation

11. D.: Shall replaces should. Gas field personnel shall immediately notify Gas Supervisor if the system's pressures are above the MAOP of the system.

11. H.: Revised - Use valves to throttle or shut down the feed to the system until the pressure is within the normal operating range. Valves shall be constantly monitored until high pressure situation is corrected.

11. K.: Revised - In the event that the system pressure has exceeded the MEP, the Gas Supervisor shall immediately contact Gas Superintendent, Supervisor Gas Tech Services and Director Pipeline Safety and Compliance. See **PRES 2.04** Overpressure Reporting for additional information.

11. L.: New - If the MEP has been exceeded, consideration should be made to at least communicate with the local fire department and/or police in case their assistance may be needed.

12. Loss and Restoration of Service

12. B.: Grammatical changes, separated 1st sentence into 2 sentences.

12. D.: New - Identify critical customers such as hospitals, nursing homes, schools or other public facilities that may need additional support or temporary supply during an outage.

12. G.: Revised - The following should be notified of the loss of service.

12. J.: Revised - Estimate manpower needs. The following should be considered when determining the appropriate staffing levels to respond to the emergency

12. G. and 12. J. removed Gas Supervisor from being the person who performs the function. These can be done by others so supervisor can concentrate operational duties.

12. M.: Turn-off requirement for an outage

12. M.(1): Revised - Turn-off the meter valve or curb valve for each affected customer: The meter valve is required to be locked

	<p><i>Requires locking the meter valve to ensure customer does not attempt to relight during the outage,</i></p> <p>12. N.: For cases where the turn-off cannot be completed without forcible entry:</p> <p>12. N. (5) (a): New - Leave a door hanger or notice notifying the customer that due to an emergency, AIC had to make a forcible entry.</p> <p>12. N. (5) (b): New - Door hanger or notice shall contain AIC's contact number 800-755-5000.</p> <p>12. N. (6): Revised - Document damage to the premise from the forced entry along with the names of those present.</p> <p><i>Note: If police officer witnessed the forced entry, record the officer's name and badge number.</i></p> <p>12. T.: Turn-on requirements for an outage:</p> <p>Removed the sentence that safety checks are not required.</p> <p>12. T. (2); "Shut in test" replaces "leak test"</p> <p>12. T. (3): "Shut in test" replaces "leak test"</p> <p>12. T. (7): Revised - AIC personnel contact an HVAC contractor to correct this type of appliance problem at AIC's expense.</p> <p>Removed sentence if service is not restored the meter valve shall be left off and locked.</p> <p><i>Meter valve is locked during the turn-off process.</i></p>	
<p>EMER 2.05</p>	<p>Natural Disaster or Civil Disobedience</p> <p>AIC replaces Ameren Illinois throughout the document.</p> <p>2. Natural Disasters</p> <p>2. B.: GTS personnel will assume responsibility for their facilities.</p> <p>2. D.: Revised - Determine if AIC facilities are damaged or in danger of failing. Communicate with the appropriate fire department the potential impact on AIC's facilities.</p> <p>2. G.: Position title change: Director Pipeline Safety & Compliance.</p> <p>2. I.: Addition - In devastated areas where uncontrolled overpressure exists or large amounts of gas are released. The local fire department should be notified of the situation and potential impact.</p> <p>3. Floods</p> <p>3. A. Prior to Flooding</p> <p>3. A.: GTS replaces the appropriate group in Gas Operations and Services.</p> <p>3. A. (3): Revised - Individual services should be shut off and locked with priority given to inside services.</p> <p>3. A. (5): Revised - If water covers pilots on interior appliances, the service should be shut off and a Warning Tag issued</p> <p>4. Civil Disobedience</p> <p>4. B. (5): Revised - If violence or any threat to AIC personnel's safety persists, personnel and surveillance patrols should be withdrawn from the area. Law enforcement and Ameren Security shall be notified.</p>	<p>January 1, 2018</p>
<p>EMER 2.08</p>	<p>Investigation of Failures</p> <p>AIC replaces Ameren Illinois throughout the document</p>	<p>April 1, 2019</p>

UNCONTROLLED IF PRINTED

	<p>2. Analysis of Failed or Defective Materials</p> <p>2. B.: Revised - By collecting and inspecting failed materials at a central location, the potential impact of the failures can be assessed, interim information communicate to operations and system-wide decisions can then be made concerning the need to take preventive measures.</p>	
FORW	<p>Forward</p> <p>5. Contacts - Updated</p> <p>Nick Skertich in Maximo, ClickMobile. ClickSchedule</p> <p>Mark Popov's Phone numbers</p> <p>Fred Halabi , Corrosion Control</p> <p>Natalie Becker, Gas Standards & Procedures</p> <p>Eddie Lynch, Gas Materials</p> <p>Eliminated Gas Standards</p>	October 15, 2018
<u>GLOS</u>	<p>Glossary</p> <p>Added definitions for:</p> <p>Downhole</p> <p>Gas Storage Well</p> <p>Observation Well</p> <p>Production Fluid</p> <p>Updated definition of:</p> <p>Underground Natural Gas Storage Facility (UNGSF)</p>	October 1, 2019
<u>INCD 0</u>	<p>Table of Contents</p> <p>INCD 4: Updated the Forms</p>	April 1, 2019
<u>INCD 1</u>	<p>Requirements</p> <p>1. Objective</p> <p>1. B.: Added - underground natural to gas storage facilities.</p> <p>1. C.: Added - Supervisor Gas Storage</p> <p>1. C. (1): New - Gas personnel or storage field personnel shall promptly verbally notify Gas Supervisor or Supervisor Gas Storage when there is a potentially reportable incident.</p> <p>2. Natural Gas Incident</p> <p>2. A.: Added - including an underground natural gas storage facility including the downhole portion of an underground natural gas storage facility</p> <p>2. A. (2): Clarified - in-patient hospitalization means at least one overnight stay</p> <p>2. A. (5): New - Unintentional estimated gas loss from the downhole portion of an underground natural gas storage facility of 500,000 cubic feet or more that occurs within 1/8 mile of a dwelling used as a residence, place of business or place of public assembly.</p> <p>3. Potential Significant Events</p>	April 1, 2019

	<p>3. B.: Added - including an underground natural gas storage facility as an AIC facility where a release of gas shall be reported to Gas Compliance.</p> <p>4. Courtesy Notification</p> <p>4. A. (5): New item which may warrant a courtesy notification - Odorizer failure resulting in either over odorization or under odorization.</p> <p>6. Reporting</p> <p>6. A.: Added - Gas Superintendent and Superintendent/Supervisor Gas Storage to those who shall contact Gas Compliance within 1 hour following confirmed discovery</p> <p>6. A. Note: Added - Confirmed discovery - See GLOS</p> <p>6. B.: Added- Illinois Department of Natural Resources (IDNR) as another agency that Compliance must notify.</p> <p>7. Gas Compliance Contact List</p> <p>Updated Mark Popov's phone numbers</p> <p>Added Nick Skertich's contact phone numbers</p> <p>8. Reporting Matrix</p> <p>8. A. Table - Report within 1 hour of confirmed discovery:</p> <p>13.; New - Unintentional estimated gas loss from the downhole portion of an underground natural gas storage facility of 500,000 cubic feet or more that occurs within 1/8 mile of a dwelling used as a residence, place of business or place of public assembly.</p> <p>8. B. Table of agencies that Gas Compliance contact:</p> <p>Added - IDNR when the incident is the result of stored natural gas from down-hole portion of gas storage facility.</p> <p>9. State & Federal Contact Numbers</p> <p>Matt Smith is now Assistant Director Pipeline Safety for ICC.</p> <p>Added - Dan Brennan, Acting Director IDNR.</p> <p>10. Corporate Claims Notification</p> <p>Updated Jackie French's title</p> <p>11. Ameren Illinois Communication Notification</p> <p>Updated Marcelyn Love's office phone number.</p> <p>14. Written Incident Report</p> <p>14. A.: Clarification - within and not to exceed 10 days</p>	
<p>INCD 4</p>	<p>Forms and Reference Materials</p> <p>Updated the 3 forms:</p> <p>PHMSA Incident Report - Gas Distribution Rev 4-2019</p> <p>PHMSA Incident Report - Gas Transmission Rev 4-2019</p> <p>Potential Incident Report Form</p>	<p>April 1, 2019</p>
<p>INVE 0</p>	<p>Table of Contents</p> <p>INVE 1: Added 3. NTSB Investigation of Incident</p>	<p>January 1, 2016</p>

UNCONTROLLED IF PRINTED

	<p>INVE 4: Added Reference 1. NTSB Pipeline Investigation Guide (Wilson Elser 2019)</p>	
<p>INVE 1</p>	<p>Requirements</p> <p>1. Objective - Added confidential before investigation</p> <p>2. General</p> <p>2. C. Added a reference to INVE 2.01 3. <i>that provides more information concerning inspection of AIC gas facilities.</i></p> <p>2. D. (3); New - Where gas is determined not to be a contributing factor consult with Ameren Claims to determine if any evidence needs to be retained in Ameren Illinois custody.</p> <p>2. F.: Revised - Gas facilities that may have failed or may have been impacted must be preserved and kept in a secured location until Corporate Claims specifies a location where facilities can be analyzed.</p> <p>3. NTSB Investigation of Incident</p> <p><i>This is a new section that has been added to provide instructions and guidance to gas personnel in the event NTSB launches an investigation of an incident.</i></p>	<p>January 1, 2016</p>
<p>INVE 2.01</p>	<p>Incident Investigation</p> <p>2. Investigation Documentation</p> <p>2. C.: New - Once Ameren Claims personnel are on the scene, they will normally be taking the photos and documenting the investigation.</p> <p><i>Only one designated person should be taking photos and documenting the investigation in order to eliminate the possibility of conflicting information if situation becomes a legal issue.</i></p> <p>2. I.: Added - Where applicable, include witness' agency, title and email address.</p> <p>2. J.: Added - (avoid including any speculation)</p> <p>2. K.: Word change - accessed replaces forfeited.</p> <p>Deleted reference to the 35 mm camera being used to supplement the investigation.</p> <p><i>Gas field personnel will have to provide access to photos taken of an incident with their cell phone if the photos are needed as evidence.</i></p> <p>2. L.: Revised - Pay special attention to areas which may include:</p> <p>2. L (9): New - Consider any other areas of interest such as sewer traps, sewer clean-outs, etc</p> <p>2. N.: Added - If witnesses are going to be available, consider waiting until Ameren Claims personnel arrive.</p> <p>2. N. (1): Revised - Describe what happened, including what was observed.</p> <p>3. Investigation of AIC Facilities</p> <p>3. D.: Check the odorant level of the gas with an odorator.</p> <p>3. D. (1): Revised - In addition to the reading performed by a qualified AIC gas personnel, request that a public official, (i.e. Police or Fire Department personnel), check the readily detectable odorant level.</p>	<p>January 1, 2018</p>

	<p>5. Analysis of the Incident</p> <p>5. D.: Revised - The report shall also contain supporting documentation as well as establishing the apparent cause of the incident.</p> <p>6. Preservation of Evidence</p> <p>6. A.: Addition - Information collected through the investigation and analysis of the gas related incident should be preserved as prescribed by AIC Gas Compliance and Ameren Legal/Claims.</p>	
INVE 2.02	<p>Investigation of Fires</p> <p>1. General</p> <p>1. A.: Addition - This section provides instructions for investigation of the apparent cause of a gas related fire, ignition, or explosion.</p> <p>2. Fire, Ignition or Explosion Investigation</p> <p>2. A.: Addition - AIC's first and foremost concern is to respond to the scene promptly, deal with any hazardous conditions that may be present, cooperate in any investigation and to render any assistance to emergency personnel that may be requested.</p> <p>5. Communication with Fire Department</p> <p>5. A.: Revised - Once determined that natural gas is suspected or confirmed to have been involved in the incident, gas field personnel should limit discussions with the Fire Departments to a designated AIC individual while continuing to cooperate to make the scene safe for the fire department and general public.</p> <p>5. B.: Revised - Any requests for investigation results should be directed to Ameren Legal/Claims.</p> <p>5. D.: Addition - The content of the investigation should remain confidential and should not be released to anyone external to Ameren without approval from Ameren Legal/Claims.</p>	January 1, 2018
INVE 4	<p>Forms and Reference Materials</p> <p>Reference Materials - New</p> <p>NTSB Pipeline Investigation Guide (Wilson Elser 2019)</p>	January 1, 2016
LEAK 2.01	<p>Indoor Leak Investigation</p> <p>1. D.: Hazardous conditions downgrade to 10% LEL from 30%.</p> <p>3. Approaching Structure</p> <p>3. B.: Revised - Before touching the gas meter, check the riser, meter and customer piping with volt stick. If voltage stick alarms refer to METR 2.20 2. A. AC Voltage on Meter Set.</p> <p>3. D.: New - Before entering ensure all personnel electronic devices, such as cell phones, are powered off and all intrinsically safe equipment, such as CGI and flashlight, is powered on.</p> <p><i>Caution: The flashlight on the volt stick is not intrinsically safe and should be left off while inside.</i></p> <p>4. Customer is Home</p> <p>4. A. Upon entering the structure;</p> <p>4. A. (3): New - Advise customer not to operate any switches or use any electronic devices, such as cell phone, while the investigation is being conducted.</p>	October 1, 2019

UNCONTROLLED IF PRINTED

	<p>4. A. (4): New - Continue to monitor the atmosphere while moving to the area where the odor is suspected.</p> <p>4. C.: Revised - An indoor concentration at the entrance of the structure or throughout the structure of 10% LEL (0.5% Gas-In-Air) or greater is an immediate hazard, and the structure should be evacuated and EMER 2.04 2. Inside Odor Compliant - Hazardous Condition implemented.</p> <p>4. D. Carbon monoxide reading of 100 PPM or greater</p> <p>4. D. (1): (b) New - Call 911, the fire department may assist with the evacuation and ventilation.</p> <p>4. D. (2): Added - Issue a Warning Tag and advise customer to contact a qualified professional to have the system checked.</p> <p>5. Customer Not Home or Can't Get Into Structure</p> <p>5. A. Revised - Before touching the gas meter, check the riser, meter and customer piping with volt stick. If voltage stick alarms refer to METR 2.20 2. A. AC Voltage on Meter Set.</p> <p>6. Leaks on Customer Facilities</p> <p>6. A. (2): Added - If simple repair cannot be made notify customer of the gas leak and advise customer they should have a qualified professional make the repairs.</p>	
<p>LEAK 2.02</p>	<p>Outdoor Leak Investigation</p> <p>2. Approaching Area</p> <p>2. B.: Word change, odor replaced leak</p> <p>4 Above Grade Gas Facilities</p> <p>4. A. (1): - Revised - Meter set: Before touching the gas meter, check the riser, meter and customer piping with volt stick. If voltage stick alarms refer to METR 2.20 2. AC Voltage on Meter Set.</p> <p>4. A. (6): New - Customer owned natural gas facilities such as; standby generators, pool heaters, barbecue, etc</p> <p>7. Hazardous Conditions</p> <p>7. A. (4): New - Suspected damaged gas facility.</p> <p><i>Added to the list of conditions that should be considered when determining if there is a hazardous condition.</i></p> <p>7. C.; Revised - If necessary, request additional resources to establish and maintain a safety zone to prevent unauthorized personnel from entering until repairs are made or the situation made safe.</p> <p>8. Leaks on Customer Owned Facilities</p> <p>8. A. (2): Revised - If simple repairs cannot be made notify customer of the gas leak and advise customer they should have a qualified professional make the repairs.</p> <p><i>Consistent language with LEAK 2.01.</i></p>	<p>October 1, 2019</p>
<p>LEAK 2.04</p>	<p>Leak Classification and Surveillance</p> <p>1. General</p> <p>1. A.: Revised - This section provides the criteria for properly classifying a gas leak.</p>	<p>October 1, 2019</p>

	<p><i>Removed "defines the gas leak classifications since that is done in LEAK 1 and doesn't need repeating.</i></p> <p>3. Description of Gas Leak Classification</p> <p><i>Replaced the descriptions with Reference to LEAK 1 3.</i></p> <p>4. Leak Classification Criteria</p> <p>4. C.: Added - or other facilities at a regulator station should be reported to Gas Tech Services.</p> <p>7. Foreign Gas</p> <p>7. A. (5): Added - Natural gas from another supplier or utility.</p> <p>7. C.: New - Contact Dispatch to notify the appropriate authority such as; fire department, municipal sewer department or pipeline company.</p> <p>8. Leak Surveillance, Repair and Recheck Schedule</p> <p>8. A. (1): Revised - Class 1 leak requires immediate repair or continuous action until the hazardous condition no longer exists. Immediate temporary measures, such as venting may be employed to protect the public and property; however, the leak remains a Class 1 leak until approved repairs are made.</p> <p>8. B. (1): Revised - Surveillance - Class 2 leak is not an immediate hazard but does have the potential of becoming a hazard which requires a surveillance to be performed once every six (6) months.</p> <p>8. C. (1): Revised - Surveillance - Class 3 leak, non-hazardous but do require a surveillance shall be performed once every fifteen (15) months to ensure leak remains non-hazardous.</p> <p>10. Repaired Leak Recheck</p> <p>10. A. Below Grade</p> <p>10. A. (3) (b): Revised - If residual gas readings are detected within zero (0) to five (5) feet from the foundation wall:</p> <ul style="list-style-type: none"> • Daily readings shall be performed until there is a 0% LEL gas reading. • If daily readings show increased levels of gas, a check shall be made for gas migration inside the structure. <p><i>Clarifies when checking inside for migration is required.</i></p>	
<p>LEAK 2.12</p>	<p>Reporting Delayed Leak Response Time</p> <p>1. B: Revised - Leak response times shall be continuously monitored to ensure that AIC is in compliance with Illinois requirements.</p> <p>2. Delayed Response Time</p> <p>2. B.: Added text - A response time in excess of 60 minutes from the time of receipt of call for an indoor or outdoor leak is considered delayed and requires an explanation.</p>	<p>January 1, 2018</p>
<p>MAIN 2.02</p>	<p>Lowering or Realignment of Pipe</p> <p>3. Steel Pipe Maximum Potential Realignment Distance (Strip Back)</p> <p>3. B. Table: Correction In the 60 psig or less for 5 ft of lowering of pipe Grade A25 is 412 ft</p>	<p>April 1, 2019</p>
<p>METR 0</p>	<p>Table of Contents</p> <p>Updated METR 2.20 Meter Header Inspection</p>	<p>October 1, 2019</p>

UNCONTROLLED IF PRINTED

	Updated METR 3.27 Residential Meter Set with Angle Valve	
METR 2.20	<p style="text-align: center;">Meter Header Inspection</p> <p><i>Inspections/Maintenance When A Meter Set is Not Disassembled and Inspections/Maintenance When A Meter is Installed/Changed Or Set is Disassembled have been combined into Inspection of a Meter Set. There were 3 additional items listed when the meter set was disassembled. These have been listed under a separate bullet point, 4. F. No reason to repeated items and by having duplicate items it was easy to miss one when making changes.</i></p> <p style="text-align: center;">4. Inspection of a Meter Set</p> <p style="text-align: center;">4. B. The following items should be checked:</p> <p style="text-align: center;"><i>Simplified and clarified the listing of items such as:</i></p> <p style="text-align: center;">4. B. (6) Meter partially buried or setting on ground</p> <p style="text-align: center;">4. B. (7) Regulator relief not freely vented to the atmosphere</p> <p>4. B. (11) Change the Note to a Warning: If the regulator may contain mercury, do not replace, remove or disturb without specific instructions from Ameren Environmental. See ABND 2.08.</p> <p>4. E.: Revised - Deficiencies should be corrected immediately or documented in ClickMobile and reported to the Gas Supervisor for follow-up action.</p> <p>4. F.: If meter set is being disassembled, the following corrective action should be taken in addition to the inspection:</p>	October 1, 2019
METR 2.24	<p style="text-align: center;">Replacement of Large Volume Diaphragm Meters</p> <p style="text-align: center;">3. Meter and Regulator Inspection</p> <p>3. A.: Revised - Before touching the gas meter, check the riser, meter and customer piping with volt stick. If voltage stick alarms refer to METR 2.20 2. A. AC Voltage on Meter Set.</p> <p style="text-align: center;"><i>Revised language for checking meter set with volt stick so that it is consistent throughout O&M.</i></p>	October 1, 2019
METR 2.29	<p style="text-align: center;">Gas Meter Bypass</p> <p style="text-align: center;">1. General</p> <p>1. C.: Revised - Before touching the gas meter, check the riser, meter and customer piping with volt stick. If voltage stick alarms refer to METR 2.20 2. A. AC Voltage on Meter Set.</p> <p style="text-align: center;"><i>Revised language for checking meter set with volt stick so that it is consistent throughout O&M.</i></p>	October 1, 2019
METR 3.03	<p style="text-align: center;">Regulator Sizing - 7 inch W.C. Delivery Pressure</p> <p>Stock Code added to the 1" x 1" Itron B42R and American 1813C with 1/4" orifice.</p> <p style="text-align: center;"><i>These were previously Non-Stocked regulators</i></p>	January 1, 2018
METR 3.04	<p style="text-align: center;">Regulator Sizing - 2 PSIG Delivery Pressure</p> <p style="text-align: center;">2. Approved Regulators for New Installations</p> <p>Correction to note for 1-1/4" Fisher CS400IR, 1/4" orifice. Note should be (9).</p>	January 1, 2018 (Current)

UNCONTROLLED IF PRINTED

	<p><i>The note was correct on the Web Viewer but the Local Viewer and Printed copy were not correct.</i></p>	<p>document dated October 1, 2019)</p>
METR 3.27	<p>Residential Meter Set with Angle Valve</p> <p>Replaces 250 Class Meter Set with System Bypass Valve.</p> <p><i>Additional instructions have been added. Same meter set design and materials</i></p>	<p>April 1, 2019</p>
OQAL 2.01	<p>Covered Task List</p> <p>Removed 0711 - Joining of Pipe - Compression Couplings</p> <p><i>In B31Q this task covers compression couplings 2" and larger, AIC does not approve of using 2" and larger couplings.</i></p>	<p>January 1, 2018</p>
POLY 0	<p>Table of Contents</p> <p>POLY 4: Added Reference 25 - GF Rotary Reeler RS Manual</p>	<p>October 1, 2019</p>
POLY 2.02	<p>Squeeze Off</p> <p><i>This section was reformatted into simple bullet points. Procedures were modified to closely follow Performance Pipe's Technical Note PP 801-TN.</i></p> <p>2. Operation</p> <p>2. A. (1) & (2): pipe gap stops replaces squeeze stops</p> <p>2. B. (1): New - Do not squeeze if there is a scratch deeper than 10% of wall thickness.</p> <p>2. C.: Revised - Prevent the build-up of static electricity charge in PE pipe when squeezing by:</p> <p><i>Removed the 1-1/4" and larger pipe since static charge can occur in any size of PE pipe. Performance pipe's procedures did not specify any specific pipe sizes.</i></p> <p>2. D.: Revised - Select and set the correct squeeze bar and pipe gap stops on the squeeze tool.</p> <p>2. G.: Revised - Operate the tool in a slow continuous manner, approximately 1 minute per inch of pipe's designated diameter (i.e. 1" CTS, 2" IPS), to allow stress relaxation in the pipe.</p> <p>2. G. (2): Revised - If air temperatures are near freezing or lower, closure should be slowed to approximately 2 minutes per inch of pipe's designated diameter.</p> <p>2. H.: Added = pipe; <i>Do not remove or alter the pipe gap stops,.....</i></p> <p>2. J.: Revised - When placing pipe back in service, slowly release the squeeze in a controlled rate at approximately 2 minutes per inch of pipe's designated diameter to allow the pipe to relax.</p>	<p>October 1, 2019</p>
POLY 2.05	<p>Electrofusion</p> <p>6. Pipe Preparation</p> <p>6. A. (4) (b): Added back in the insertion depth of 2-1/4" for the Central Plastic 2 inch elbow.</p>	<p>October 1, 2019</p>

	<p>6. A. (5): Added "wiping in one direction and discarding wipe or towel" back into the cleaning instructions.</p> <p><i>These 2 items were inadvertently left out when format of POLY 2.05 was changed to text vs chart in the October 1, 2019 Update. Wiping in one directions and discarding towel is in Central Plastic's electrofusion training instructions.</i></p>	
POLY 4	<p>Forms and Reference Materials</p> <p>Added Reference 25 - GF Rotary Peeler RS Manual</p>	January 1, 2019
PTST 0	<p>Table of Contents</p> <p>Updated Forms: LTF19 and LSTF19</p>	January 1, 2018
PTST 4	<p>Forms and Reference Materials</p> <p>Updated Forms:</p> <p>Leak Test Form LTF19</p> <p>Leak & Strength Test Form LSTF19</p> <p>Added a Note:</p> <p>Leak Test Form LTF17 or LTF18 and Leak & Strength Test Form LSTF17 or LSTF18 that are in job packets remain acceptable documentation. Those forms remain acceptable until supply is depleted.</p>	January 1, 2018
PUBL 0	<p>Table of Contents</p> <p>PUBL 4 - Reference Materials</p> <p>Updated the 4 existing documents</p> <p>Added 11 additional documents</p>	January 1, 2018
PUBL 2.01	<p>Public Notification</p> <p>6. Records</p> <p>6. D.: Revised - The brochure and Ameren Illinois fact sheet will be sent to public officials once every 2 years.</p> <p><i>Brochure and Ameren Illinois fact sheet replaces notification letter. Distribution changed from 3 years.</i></p>	October 15, 2018
PUBL 2.02	<p>Liaisons with Fire, Police and Public Officials</p> <p><i>AIC replaces Ameren Illinois throughout this document.</i></p> <p>1. B.: Revised - This periodic contact should include, a mailing to fire and police annually and public officials once every 2 years and/or a face-to-face visit.</p> <p>3. Mailing</p> <p>3. B.: Revised - 3. Mailing The sample Operator page and brochure for the public official mailing every 2 years is provided in this section of the O&M Plan. The brochure, Public Officials Along Transmission Pipelines and in our Service Areas, is in PUBL 4 Reference Materials.</p>	October 1, 2019
PUBL 4	<p>Forms and Reference Materials</p> <p>Reference Materials:</p>	January 1, 2018

UNCONTROLLED IF PRINTED

	<p style="text-align: center;">Updated: Ameren Public Awareness Program Emergency Responder Brochure Natural Gas Safety Flyer</p> <p style="text-align: center;">Added 11 new brochures that are distributed to various groups.</p>	
<p>PURG 0</p>	<p style="text-align: center;">Table of Contents</p> <p style="text-align: center;">Added - PURG 4 Forms and Reference Materials</p> <p style="text-align: center;">Form 1: Purge Stamp</p> <p style="text-align: center;"><i>Moved from ABND 4</i></p>	<p style="text-align: center;">October 15, 2018</p>
<p>PURG 2.01</p>	<p style="text-align: center;">Purging Methods</p> <p style="text-align: center;">1. General</p> <p style="text-align: center;">1. A.: Reformatted, expanded -</p> <p>A. This section outlines the procedures to be followed when purging:</p> <p style="padding-left: 40px;">(1) Transmission lines.</p> <p style="padding-left: 40px;">(2) High pressure distribution mains.</p> <p style="padding-left: 40px;">(3) Distribution mains</p> <p style="padding-left: 40px;">(4) Service lines 2 inches and larger and 500 feet or longer.</p> <p style="padding-left: 20px;">(5) Service lines 2 inches and larger, 100 feet or longer and operating above 100 psig.</p> <p>B. Gas Engineering, Gas Tech Engineering (GTE) or Gas Storage Engineer will provide detailed purging plans, prior to blow-down or purging operations on: (Refer to tables below)</p> <p style="padding-left: 40px;">(1) Transmission lines 100 feet and longer.</p> <p style="padding-left: 20px;">(2) High pressure distribution mains 100 feet and longer.</p> <p style="padding-left: 40px;">(3) Service lines 2 inch and larger, and</p> <p style="padding-left: 80px;">(a) 100 feet or longer in length, and</p> <p style="padding-left: 80px;">(b) Operating at more than 100 psig.</p> <p style="padding-left: 40px;">(4) Projects utilizing an air mover.</p> <p style="text-align: center;"><i>Reformatted and revised to be consistent with ABND 2.01 and tables in PURG 2.01.</i></p> <p style="text-align: center;">5. Purging of Gas with Air During Abandonment</p> <p style="text-align: center;">5. F.: Word changes - The 2 tables</p> <p style="padding-left: 40px;">Service Line Smaller than 2 inch and less than 500 feet in length</p> <p style="padding-left: 80px;">and</p> <p style="padding-left: 40px;">Service Line Smaller than 2 inch but 500 feet or longer in length</p> <p style="text-align: center;"><i>Needed corrected to be consistent with ABND 2.0.</i></p> <p>5. F. Tables: Added the following 2 items that require a Purge Plan in the Operating Pressure 100 PSIG or Less table:</p> <p style="padding-left: 40px;">Air Mover utilized to purge</p> <p style="padding-left: 20px;">Joint Abandonment of Distribution Main and Services (ABND 2.01 2. B.)</p>	<p style="text-align: center;">October 1, 2019</p>

UNCONTROLLED IF PRINTED

	<p>Added the following 2 items that require a Purge Plan in the Operating Pressure Greater than 100 PSIG table:</p> <p style="text-align: center;">Air Mover utilized to purge</p> <p style="text-align: center;">Joint Abandonment of Transmission Line or HP Distribution Main and Services (ABND 2.01 2. A.)</p> <p style="text-align: center;"><i>Joint abandonment is addressed in ABND 2.01 and the air mover is addressed in PURG 2.01 8. They were added to the table to avoid confusion as to expectations.</i></p> <p style="text-align: center;">7. Required Minimum Inlet Pressure</p> <p>7. A.: Added - Consult with Gas Tech Engineering for pipe sizes not shown in the Table 1 or Table 2.</p> <p style="text-align: center;">8. Vacuum Purge / Air Mover</p> <p>8. D.: Added engineering groups - When an air mover(s) is to be utilized to purge, Gas Engineering, GTE or Gas Storage Engineer will provide a purging plan using AGA's Purging Principals and Practice as a general basis for the plan</p>	
<p>PURG 4</p>	<p style="text-align: center;">Forms and Reference Materials - New section</p> <p style="text-align: center;">Moved Purge Stamp to PURG 4 from ABND 4.</p>	<p style="text-align: center;">New</p>
<p>REGS 2.06</p>	<p style="text-align: center;">Gas Heaters</p> <p style="text-align: center;">3. Indirect Heaters</p> <p style="text-align: center;">3. C.: Typical Spring Shut-down</p> <p style="text-align: center;">3. C. (3): Revised and reformatted</p> <p style="text-align: center;">(4) Where heater bypass provision exists:</p> <p style="text-align: center;">(a) Open bypass valve to heater.</p> <p style="text-align: center;">(b) Monitor downstream system pressure with pressure gauge.</p> <p style="text-align: center;">(c) Close inlet valve at heater so gas does not pass through heater coil.</p> <p style="text-align: center;">3. D. Typical Fall Start Up</p> <p style="text-align: center;">3. D. (16): New</p> <p style="text-align: center;">(16) Where heater bypass provisions exists:</p> <p style="text-align: center;">(a) Monitor downstream system pressure with pressure gauge.</p> <p style="text-align: center;">(b) Open inlet valve at heater so gas passes through the heater coil.</p> <p style="text-align: center;">(c) Verify heater outlet valve is in the open position and close bypass valve to heater.</p>	<p style="text-align: center;">January 1, 2018</p>
<p>REGS 3.01</p>	<p style="text-align: center;">Regulator Station Design</p> <p style="text-align: center;">GTE replaces Gas Tech Engineering throughout the document</p> <p style="text-align: center;">1. General</p> <p>1. C.: Revised - Regulator stations should be designed by Gas Tech Engineering (GTE).</p> <p style="text-align: center;">2 General Guidelines and Requirements</p> <p style="text-align: center;">2. E. Cathodic protection insulation</p> <p>2. E. (2): New - Install welded bolts and jumper wire/flange fink on one run. See CORR 3.13 Flange Fink Test Station for installation details.</p>	<p style="text-align: center;">April 1, 2019</p>

UNCONTROLLED IF PRINTED

	<p>2. E. (6): Revised - Cathodic protection design for station should be reviewed by the Corrosion Control, GTE, or Division Engineering personnel. Refer to CORR 2.01 for additional cathodic protection details.</p> <p>2. I.: Formatted into bullet points.</p> <p>3. Standardized Design Features</p> <p>3. L. Revised - Provide additional layer of protection (wrapping, FRP, rock shield, etc) on all pipe in contact with below grade pipe supports. For above grade pipe supports see CORR 2.23 3. B. (2) Preformed FRP Spacers -Type 120.</p> <p>3. 7.: Revised - 1" 289H (or equivalent)</p> <p>4. Standardized Regulator Station Drawings</p> <p>4. C.: Removed the language regarding the title block</p> <p>Updated the tables, removed: RS000 Title Block row and Outlet Flow Rate column.</p> <p>Reformatted the Notes below the table.</p> <p><i>These updates were provided by Gas Tech Engineering to improve cathodic protection monitoring, atmospheric corrosion at pipe supports.</i></p>	
<p>SERV 2.02</p>	<p>Excess Flow Valves or Manual Shut-Off Valve</p> <p>8. EFV Sizing</p> <p>8. E.: Added - 2 inch IPS</p> <p>8. F.: Reformatted and Revised -</p> <p>8. F. When selecting an EFV the following should be taken into consideration:</p> <p>(1) Lowest anticipated inlet pressure - cannot drop below 10 psig.</p> <p>(2) Service line size (i.e. 1" CTS requires 1" EFV).</p> <p>(3) Length of service line must be less than maximum length in the tables below.</p> <p>(4) Maximum capacity of the meter being specified or could be specified shall not exceed maximum design flow in tables below.</p> <p>8. G. EFV Sizing Tables</p> <p>8. G. (4): Added new 2 inch UMAC Series 5500 EFV.</p> <p>8. G. (2) & (3): Update Maximum Flow and Maximum Length values.</p> <p><i>Ran all of our UMAC EFVs through UMAC's updated sizing calculator and updated the tables for the 1 inch and 2 inch EFVs</i></p> <p>8. G. (6): Correct stock code, 39 22 635, for the 1" x 1/2" CTS reducer coupling with EFV.</p>	<p>October 1, 2019</p>
<p>TURN 2.01</p>	<p>Residential/Small Commercial Customer</p> <p>4. Existing Service Connect</p> <p>4. A.: Revised - Before touching the gas meter, check the riser, meter and customer piping with volt stick. If voltage stick alarms refer to METR 2.20 2. A. AC Voltage on Meter Set.</p> <p><i>Revised language for checking meter set with volt stick so that it is consistent throughout O&M.</i></p>	<p>October 1, 2019</p>

<p>TURN 2.03</p>	<p style="text-align: center;">Discontinuance or Transfer of Gas Service</p> <p style="text-align: center;">4. Hard Disconnect (Terminate Service)</p> <p>4. C.: Revised - Before touching the gas meter, check the riser, meter and customer piping with volt stick. If voltage stick alarms refer to METR 2.20 2. A. AC Voltage on Meter Set.</p> <p style="text-align: center;"><i>Revised language for checking meter set with volt stick so that it is consistent throughout O&M.</i></p>	<p style="text-align: center;">October 1, 2019</p>
<p>VALV 2.01</p>	<p style="text-align: center;">Valve Installation</p> <p style="text-align: center;"><i>All of the changes reflect incorporating gas storage field into these procedures.</i></p> <p>1. A.: Revised - This section provides requirements for the installation of pipeline valves, both emergency and non-emergency and storage field emergency and non-emergency master and wing valves.</p> <p>1. E.: New - Gas Storage Facility and Reservoir Engineering will provide the designation and location of emergency and non-emergency valves within gas storage field areas.</p> <p style="text-align: center;">5. Non-Emergency Valves</p> <p>5. B. Valves that could be used to sectionalize or isolate areas of a system such as:</p> <p style="text-align: center;">5. B. (4): New - Isolation of gas storage field wells</p> <p>5. C.: Revised - The location of these valves will be determined by the Gas Engineering, Gas Supervisor, Distribution Design Center, Gas Tech Engineering, Gas Storage Facility and/or Reservoir Engineers or Gas Storage Supervisor.</p> <p>5. D. As a guideline for placement of these valves ..</p> <p style="text-align: center;">5. D. (5): New - Gas storage field wells</p> <p style="text-align: center;">6. Valve Installation Operations</p> <p style="text-align: center;">6. A. Steel Valves</p> <p>6. A. (2): Revised - The valve body must be compatible with the pipeline and/or gas storage field wells on which it is being connected.</p>	<p style="text-align: center;">January 1, 2016</p>
<p>VALV 2.02</p>	<p style="text-align: center;">Valve Inspection and Maintenance</p> <p style="text-align: center;"><i>All of the changes reflect incorporating gas storage field into these procedures.</i></p> <p>1. A.: Revised - This section describes the inspection and maintenance procedures for all transmission, distribution emergency valves and gas storage field emergency and non-emergency valves.</p> <p style="text-align: center;">2. Valve Inspection</p> <p style="text-align: center;">2. A.: Valves inspected each calendar year</p> <p style="text-align: center;">2. A. (2): New - Each gas storage field emergency valve.</p> <p style="text-align: center;">2. A. (3): New - Each gas storage field master and wing valve.</p> <p style="text-align: center;">5 Records</p> <p>5. A.: Revised - The results of all emergency valve and gas storage field non-emergency valve inspections shall be recorded, by the qualified gas field personnel or gas storage field personnel performing the inspection, on the ClickMobile inspection form.</p>	<p style="text-align: center;">December 1, 2014</p>

	<p>5. B.: Revised - Any data correction or update should be reported on the Click-Mobile inspection form. Gas Supervisor, Gas Storage Field Supervisor, Gas Storage Facility/Reservoir Engineer or Gas Engineering is responsible for ensuring data corrections are made within Maximo.</p>	
WELD 0	<p>Table of Contents</p> <p>WELD 4: Updated References 10, 58, 59 & 60</p> <p>Added - 8 WPS's for Gas Storage Field Well Head Welding</p>	October 1, 2019
WELD 1	<p>Requirements</p> <p>1. D. Correction, remove "Dry" from Magnetic Particle Testing.</p>	October 1, 2019
WELD 4	<p>Updated References 10, 58, 59 & 60</p> <p>Added - WPS's for Storage Field Well Head Welding</p> <p>GS WH 01 H-40 to J-55 WPS BUTT ASME IX</p> <p>GS WH 02 J-55 to J-55 WPS BUTT ASME IX</p> <p>GS WH 03 K-55 to K-55 WPS BUTT ASME IX</p> <p>GS WH 04 K-55 to J-55 WPS BUTT ASME IX</p> <p>GS WH 05 K-55 to H-40 WPS BUTT ASME IX</p> <p>GS WH F01 K-55 to 4130 WPS Fillet ASME IX</p> <p>GS WH F02 J-55 to 4130 WPS Fillet ASME IX</p> <p>GS WH F03 H-40 to 4130 WPS Fillet ASME IX</p>	October 1, 2019
WWBG 2.01	<p>Hazardous Atmosphere</p> <p>3. Safe Zone</p> <p>3. B. Responding to a Small Diameter Cut PE Service</p> <p>3. B. (c): Revised - Squeeze off the service line from an above grade position with only an arm extended into the excavation. The head must remain out of the excavation, or</p> <p>3. B. (d): Use an above grade squeeze tool per POLY 2.02 3. Squeeze Off</p> <p><i>Made using above grade squeezer a separate point to eliminated the confusion that the above grade squeezer could only be used on small diameter PE services</i></p>	October 1, 2019

Supersedes: October 1, 2019

CHANGE SUMMARY

October 1, 2019

Change Summary October 1, 2019

Major Changes in this Update

Since there has been a regulatory ruling that only Operator Qualified people are allowed to operate our gas meter valve, the valve must be locked when the meter valve is used to shut-off the gas supply to the meter. There is one exception and that is when there is an outage an all of the meters have to be turned off, the valve does not have to be locked. Refer to EMER 2.04 10. for the details.

In the following O&M sections: EMER 2.04 6., EMER 2.04 7., LEAK 2.01 6. and LEAK 2.02 8. disconnecting and capping the meter outlet is no longer an approved method of isolating a leak. The meter valve is to be close and locked.

Leaks on customer facilities can still be isolated at the appliance control valve or at a customer valve downstream of the meter. In this case, the meter valve will be left on and unlocked.

METR 1 and TURN 2.01:

On new installation, either a System Bypass valve or a Lock Wing valve should be installed downstream of the meter outlet. It is encouraged to install one of these valve when replacing, relocating or rebuilding a meter set.

TURN 2.01;

Meter sets with System Bypass valve or customer valve, following a successful low flow test and shut-in test the meter valve can be left in the open position and the Bypass valve or customer valve closed. A Meter Relight Tag should be given to the customer.

If the low flow and shut-in test fails, the meter valve shall be closed and lock unless the leak can be isolated at the appliance control valve or customer valve.

SERV 1 10. A new service line where a meter is not installed shall have the meter valve closed and locked.

CORR 2.09 Application of the Denso 7125, 7200 and 7300 products are to be done in accordance with Denso's instructions in the Reference Materials section of CORR 4.

EMER 2.04 When responding to Outdoor Odor Complaints or Major Leaks or Line Breaks gas field personnel must first ensure that gas has not migrated into nearby structures or sewer lines before they begin to determine the extent of the migration.

LEAK 2.04 Guidelines on how to classify a leak in an area covered by or saturated with water.

METR 1 & SERV 1 Meters and risers are to be located where venting gas will not accumulate

METR 1 Effort should be made to install a system bypass valve or lock wing valve downstream of the meter outlet when installing, replacing, relocating or rebuilding a meter set.

METR 2.20	3. & 4. Inspection/Maintenance on Meter Sets: Banded regulators with corroded bolts are to be replaced not repaired
POLY 1	8. Weak Link: Smaller diameter PE pipe can no longer be used as a weak link when pulling PE pipe. Added Stock Codes for Cumberland MDPE & HDPE Weak Links.
POLY 2.11	Maintenance of Fusion Equipment is a new section that provides general requirements on maintaining electrofusion and butt fusion equipment. A with the EF Processors, all butt fusion machines will be entered in Maximo so their inspections can be recorded and tracked.
PTST 2.01	3. Leak Test Duration: The minimum required test duration for a segment of main consisting of different pipe sizes is now determined by calculating the duration for each pipe size and length and adding those durations together.
PURG 2.01	4. C. When purging air from a service line 2" and smaller, a CGI is not required to detect gas. 5. D. The riser being used as the purge point at the site of injection should be checked for zero pressure before introducing the purge medium.
REPR 1	A manufactured fitting such as Mueller or T.D.W. line stopper, shortstop, save-a-valve nipple can be used to encapsulate a leak in addition to a leaking or abandoned fitting on all steel lines; transmission, high pressure distribution and distribution. Gas Tech Engineering and Integrity Management are to be consulted to determine if encapsulation is an acceptable repair option. 4. Steel Distribution Pipe Repair: Compression couplings are no longer approved for Make Safe repairs.
SERV 2.02	11. New test requirement for a service line with an EFV prior to placing the line into operation. Once the service line and meter set riser are installed, pressure tested and purged, perform a functional flow test through the meter valve to ensure EFV will operate properly. If the EFV does not activate, it will need to be replaced with a properly size EFV.
WELD 2.04	If a tap is going through an known longitudinal seam on transmission or 4 inch and larger high pressure distribution pipe, the seam is to be ultrasonically analyzed. All transmission lines shall be UT tested for laminations prior to any in-service welding or installation of a fitting used to tap the pipe. UT testing for laminations on 4 inch and larger high pressure distribution lines with MAOP of 100 psig or greater should be performed prior to any in-service welding or installation of a fitting used to tap the pipe
WWBG 2.02	Level 2 PPE Ensemble: The Level 1 single layer coveralls are to be worn under either the Bulwark or Silver Needle Level 2 insulated coverall.

Document Change Summary		Previous Document Dated	Current Document Dated
CORR 0	<p>Table of Contents</p> <p>CORR 2.09: Protal Applications replaces Protal 7200</p> <p>Removing CORR 2.10 Protal 7125</p> <p>Removing CORR 2.17 AC Voltage</p> <p>Removing CORR 2.32 Protal 7300</p> <p>CORR 4 Forms and Reference Materials:</p> <p>Updated the Denso Protal Products Instructions</p> <p>Added Reference 40. Denso's Letter Applications Procedures</p>	April 1, 2019	October 1, 2019
CORR 1	<p>Requirements</p> <p>8. Cathodic Protection Monitoring</p> <p>8. D. Rectifiers</p> <p>8. D. (2): Added - Inspection current and voltage output will be recorded in Maximo</p> <p>8. D. (3): New - Remotely monitoring of the current and voltage output is an acceptable inspection method.</p>	April 1, 2019	October 1, 2019
CORR 2.03	<p>Coating</p> <p>1. Approved Coatings</p> <p>1. A. (1) (a) and 1. A. (2) (a):</p> <p>Update the FBE mil coating thickness to standard 16 mil with minimum of 12 mil and maximum of 28 mil for both direct bury and directional drilling installations</p> <p>1. A. (1) (c) and 1. A. (2) (c):</p> <p>Under Field Applied Liquid Epoxy removed references to Protal 7200 and Protal 7125. Replaced with reference to CORR 2.09 which is now Protal Applications.</p> <p>Application of the Protal products will be in accordance with Denso's instructions which are contained in CORR 4.</p> <p>1. E. Fittings:</p> <p>1. E. (1) Removed Coal tar epoxy (Bitumastic)</p> <p>4. Approved Field Applied Epoxy Coatings</p> <p>Correction made, these coatings are approved for both above and below ground use.</p> <p>Above grade had been left out in earlier editions.</p> <p>7. Approved Paint Specifications</p>	April 1, 2019	October 1, 2019

7. A, Approved Paints

7. A. (3): Removed "town border stations" and "with a primer"

7. A. (4): Wording change - "can be touched up" replaces "and are painted". Added "until a total repaint is necessary".

7. A. (4) (c): Added Stock Code for Red Primer, Enamel

CORR 2.09	<p>Protal Applications</p> <p>This is a new section which contains general information common to the three Denso Protal products used at AIC.</p> <p>In addition, a copy of Denso's letter stating that any size of brush, applicator pad or roller can be used to apply the three Protal products is being placed in the Reference Materials section. Letter was needed because Denso instructions states a 4" brush is to be used for application.</p> <p>This section states application of the three products is to be done in accordance with Denso's instructions contained in CORR 4 Reference Materials.</p> <p>Application of field applied liquid epoxy will be a Covered Task and individuals must be specifically qualified in the application of this material.</p>	New	October 1, 2019
CORR 2.10	<p>Protal 7125 - This section is being removed. AIC will follow Denso's Protal 7125 Instructions for application. Those instructions are in CORR 4.</p>	January 1, 2018	October 1, 2019
CORR 2.12	<p>Tapecoat TC Color Coat</p> <p>Remove the Tapecoat Profile Putty table since AIC no longer stocks this item.</p> <p>Tapecoat Profile Putty was removed from CORR 2.03 list of approved coating products because Tapecoat had added an expiration date to the profile putty.</p>	January 1, 2014	October 1, 2019
CORR 2.15	<p>Coating Inspection</p> <p>2. Inspection Requirements</p> <p>2. B. Inspection Voltage</p> <p>2. B. (2) and (3): Updated the maximum coating mil thickness for FBE only coating (28 mil) and for FBE and ARO coating (58mil)</p>	January 1, 2018	October 1, 2019
CORR 2.17	<p>AC Voltage - This section is being removed. AC voltage on gas meter has been incorporated into METR 2.20 Meter Header Inspection.</p>	January 1, 2018	October 1, 2019
CORR 2.32	<p>Protal 7300 - This section is being removed. AIC will follow Denso's Protal 7300 Procedures for application. Those procedures are in CORR 4.</p>	April 1, 2019	October 1, 2019

CORR 3.14	<p>Test Lead Wire Attachment</p> <p>1. General</p> <p>1. C.: Revised terminology - MAOP of 100 psig or less replaces distribution main operating at or below 100 psig.</p> <p>2. Cadweld Thermite Welding Process</p> <p>2. A. (2): Updated - Crimp sleeve to #12 and #14 wire. Sleeve is not required for #8 wire.</p> <p>6. Welded Bolt Anode Wire or Test Lead Connection to Steel Pipe</p> <p>6. A.: Revised terminology - "MAOP of 100 psig or less" replaces "operating at or below 100 psig"</p>	October 15, 2018	October 1, 2019
CORR 4	<p>Forms and Reference Materials</p> <p>Updated with latest version from Denso's website:</p> <p>Denso Protal 7200 Repair Cartridge Data Sheet</p> <p>Denso Protal 7125 Instructions</p> <p>Denso Protal 7200 Instructions</p> <p>Denso Protal 7300 Procedures</p> <p>Denso Protal Air Cartridge Gun 1000 Set-up</p> <p>Added: Reference 40. Denso's Letter Applications Procedures</p>	April 1, 2019	October 1, 2019
EMER 0	<p>Table of Contents</p> <p>EMER 2.10 CNG Trailer Added CNG Filling Stations and CNG Cylinders</p> <p>EMER 4 - Updated the Ameren Shipping Paper for CNG</p>	April 1, 2019	October 1, 2019
EMER 2.02	<p>Dispatch Center</p> <p>3. Cold Weather Electrical Outage and Restoring Electrical Service</p> <p>3. C.: Updated contact information for Gas Planning</p>	October 15, 2018	October 1, 2019
EMER 2.03	<p>Emergency Responder</p> <p>1. General</p> <p>1. A.: Rearranged wording</p> <p>2. Upon Arrival (Inside Leak)</p> <p>2. C. Updated reference link to METR 2.20 2. A. for the AC Voltage on Meter Set</p> <p>Upon Arrival (Outside Leak)</p> <p>3. B.: New - Avoid parking over manholes as they may be within the gas leak migration pattern and could possibly be venting.</p>	October 15, 2018	October 1, 2019

3. C.: New - Avoid parking over main valves in the event that they are required for make safe actions.

4. Upon Arrival (Cut Main or Service)

4. F.: New - Direct emergency response personnel to assist with the evacuating buildings in the immediate are for safety, if needed.

EMER
2.04

Gas Field Personnel

April
1,
2019

Octo-
ber 1,
2019

3. Outside Odor Compliant - Hazardous Condition\

3. B: Added - including surrounding buildings when monitoring gas concentrations. Evacuate as required.

4. Major Leaks or Line Breaks

4. B.: Revised - Evaluate the situation, determine where gas is migrating and if it is creating an immediate hazard to people or property.

Added:

- (1) Check for leak migration into buildings first,
- (2) If the buildings are clear then proceed with checking for migration into sewer lines, catch basins and conduits
- (3) If the leak was caused by excavation or boring damage, additional investigation is required due to the possibility of multiple leaks (i.e, service pulled out of tee)

Strengthens the importance for initially checking that gas has not migrated into structures and checking the potential migration routes into structures.

6. Fire, Ignition or Explosion - Gas Related

6. F. Contact with Fire Chief:

6. F. (2) and (3): Removed disconnect and cap from both sections.

6. F. (3): Added - when safe to approach

6. I. Control the flow of gas

6. I. (2): New - Be aware that extinguished gas ignition before the flow of gas is isolated may reignite or migrate into locations where levels can accumulate and potentially lead to an explosion.

Additional safety reminder for those working and those monitoring gas concentrations.

7. Fire, Ignition or Explosion - Non-Gas Related

7. B. Contact with Fire Chief:

7. B. (2) and (3): Removed disconnect and cap from both sections.

7. C.: Added - when safe to approach

UNCONTROLLED IF PRINTED

The meter valve will have to be locked in the closed position so that it cannot be operated by an unauthorized person. The meter must be safe to approach when verifying the valve is off and locking the valve.

12. Loss and Restoration of Service

12. S. Turn-on requirements for an outage 12. S. (9): New - If the service is not restored, the meter valve shall be left in off position and locked. Leave a door hanger advising customer call in to have their service restored.

Meter valve cannot be left unlocked in the off position since the customer is not authorized to operate AIC meter valve.

EMER 2.10	<p>CNG Trailers</p> <p>2. Trailers by Location and Capacity</p> <p>Updated the contact information</p> <p>5. CNG Filling Stations - New section</p> <p>Updated the CNG Filling Locations</p> <p>6. CNG Cylinders - New section</p> <p>6. A. CNG cylinders must be inspected and hydrostatically tested every 5 years by an approved testing facility.</p> <p>7. Requirements</p> <p>7. E.: Update the sample of the Ameren Shipping Paper with Gerry Turner's signature in Shipper's Authorized Signature.</p>	<p>April 1, 2013</p>	<p>October 1, 2019</p>
EMER 4	<p>Forms and Reference Materials</p> <p>Updated Ameren Shipping Paper for CNG</p>	<p>April 1, 2019</p>	<p>October 1, 2019</p>
<u>GLOS</u>	<p>Glossary</p> <p>Acronyms:</p> <p>Added: AMI and AMR</p> <p>Glossary:</p> <p>Added:</p> <p>Automatic Shut-off Valve</p> <p>Control Valve</p> <p>JULIE to J.U.L.I.E.</p> <p>Lock-up</p> <p>Regulator Set-point</p> <p>Remote Operated Valve</p> <p>Slam Shut Valve</p> <p>Vent Limiter</p>	<p>October 1, 2018</p>	<p>October 1, 2019</p>

Weak Link

Revision to Maximum Allowable Operating Pressure

Revision to Relief Valve

Correction in Pit: allow replaces all

LEAK
0

Table of Contents

April
1,
2019

Octo-
ber 1,
2019

LEAK 4: Updated the Southern Cross manuals for the Flame Pack 400 and the All-Terrain Vehicle

LEAK
1

Requirements

Janu-
ary 1,
2013

Octo-
ber 1,
2019

2. Leak Investigations

2. D.: Revised - While performing a gas leak investigation at the customers premise, gas field personnel should use their nose to sniff test the gas to ensure the odorant is readily detectable and document it. See LEAK 2.03 3. F. or LEAK 2.03 4. D.

Revised to be consistent with the language in LEAK 2.03 and ODOR 2.03 on performing a sniff test to check if odorant is readily detectable

LEAK
2.01

Indoor Leak Investigation

April
1,
2019

Octo-
ber 1,
2019

3. Approaching Structure

3. B.: Updated reference link to METR 2.20 2. A. for the AC Voltage on Meter Set

4. Customer is Home

4. E. Investigate source of leak

4. E. (3) (f): Added - Any other points of entry into the structure. When checking openings to a structure.

Added reminder the importance of checking all possible points of entry to ensure gas has not migrated into the structure.

6. Leak on Customer Facilities

6. A. (2) (a): Isolate the gas leak upstream of leak:

Removed - "Disconnect and cap outlet of meter set or Plug and cap outlet of meter".

Since operating AIC's gas meter valve is classified as a "Covered Task", the above options for isolating a leak and leaving our meter valve unlocked are no longer applicable

7. Records

7. A.: Removed "for all leaks on company facilities".

LEAK
2.02

Outdoor Leak Investigation

Octo-
ber

Octo-
ber 1,
2019

4. Above Grade Gas Facilities

UNCONTROLLED IF PRINTED

4. A. .: Updated reference link to METR 2.20 2. A. for the AC Voltage on Meter Set 15, 2018

5. Below Grade Gas Facilities

5. B. (1): Added a Warning: If gas is detected at the foundation of a structure, the structure shall be immediately checked for the possible presence of gas.

When checking for gas migration, the first priority is to ensure gas has not migrated into a structure. If gas is detected at the foundation, the structure should be checked before continuing with the sampling or by another gas person present.

5. F. If gas is detected in sewer

5. F. (1): Consideration should be given for possible migration into premise bullet point was moved from the bottom of the listing to the top.

This was done to emphasize the importance of protecting the public by ensuring gas has not migrated into a structure.

7. Hazardous Condition

7. A. (5): New - Gas along a foundation when there is no access to the structure.

7. A. (6): New - Any leak, which in the judgement of qualified personnel at the scene, is regarded as potentially hazardous.

A couple of new situations a consultant recommended be included to ensure the protection of the public

8. Leaks on Customer Owned Facilities

8. A. (2) (b): Removed - "or by disconnecting the affected fuel line from the meter set".

Isolating a gas leak can only be done by turning-off a customer owned valve downstream of the meter or by turning -off and locking AIC's meter valve.

LEAK 2.04

Leak Classification and Surveillance

2. Leak Classification

2. G.: New - Procedures have been added for classifying a leak covered by water where bubbles are an indicator of a leak.

G. In an area covered or saturated by water where bubbles are the indicator of a leak the following procedures should be followed:

(1) Determine if the leak is bubbling or blowing.

(2) Blowing gas shall be classified as a Class 1 leak and handled appropriately.

October 15, 2018 October 1, 2019

(3) If gas is bubbling, assume the entire area underwater has a reading of 100% gas since a CGI cannot obtain a gas reading underwater.

(a) Zero out the gas leak in a minimum of four directions and classify accordingly.

- **Leak migration must be checked by doing a thorough leak investigation following the procedures outlined in LEAK 2.02 5. Below Grade Facilities**

(b) If the leak cannot be zeroed out in a minimum of four directions, the leak shall be classified as a Class 1 leak and handled appropriately

There is a gap in procedures that does not address gas leaks underwater where bubbling water is the indicator of the leak, management felt that this needed addressed in the O&M.

10. Repaired Leak Recheck

10. A. Below Grade

10. A. (3) (b): Expanded requirement when residual gas readings are within 0 to 5 feet of a foundation to now include an investigation of the structure to ensure gas has not migrated inside.

Important in the protection of the public to ensure gas is not present inside the structure.

<u>LEAK</u> 4	Forms and Reference Materials	April 1, 2019	Octo- ber 1, 2019
	Updated the Southern Cross manuals for the Flame Pack 400 and the All-Terrain Vehicle		
METR 0	Table of Contents	April 1, 2019	Octo- ber 1, 2019
	METR 2.20: Added AC Voltage on Meter Set and AC Voltage Action Table		
	METR 2.24: Meter Header Inspection replaces Additional Checks and Leak Checks replaces Leak Investigation		
	METR 2.27: Removed: Device Programming Verification, Device Installation Verification, and Corrector Edit Calculation		
METR 1	Requirements	Janu- ary 1, 2017	Octo- ber 1, 2019
	3. Location		
	3. E.: In addition to installing a residential meter within 3 feet of the building wall it should also be located where venting gas will not accumulate.		
	3. F. Updated reference link Section I. (1) though (10)		
	4. Installation		

4. C.: New

C. Effort should be made to install one of the following, downstream of the meter bar outlet, on new, replaced, relocated or rebuilt gas meter sets, where possible:

- (1) A system bypass valve, see METR 3.27, or
- (2) A lock wing ball valve

By installing a valve downstream of the meter bar outlet, AIC will be able to shut-off that valve and leave our gas meter valve left on. This will provide the customer with a means of shutting off their gas service without involving AIC.

5. Regulator Vent Lines

5. B. (2): Added, Street elbows shall not be used.

Street elbows restrict the flow since the main end has a reduced ID.

5. E. Vent line termination shall be located such that:

5. E. (1) Reformatted - Gas can escape freely into the atmosphere

5. E. (2) Reformatted - Water, ice or snow cannot block the opening.

5. F.: Reformatted - The vent piping shall be gas-tight and terminate with either a bug screen facing down or a rain cap.

If a hinged rain cap is used, care should be taken when painting so as not to paint the cap shut or affect its operation

METR 2.09	<p>Gas Meter Retirement</p> <p>2. Criterial for Meter Retirement</p> <p>2. B.: Added the following meters to retirement list:</p> <p>All American AL175, AL225 and AL250 meters.</p> <p>The large body Sprague 400 meters (MC01231).</p> <p>All Sprague 675 and 1000 meters</p> <p>All Rockwell R175, R200 and R250 meters</p> <p>All Rockwell 310, 315 and 415 meters</p>	<p>Janu- ary 1, 2017</p>	<p>Octo- ber 1, 2019</p>
METR 2.12	<p>Rotary Meter Differential Testing</p> <p>5. Differential Test</p> <p>5. G.: Added Romet Differential Calculator and a Caution note: Caution: Be sure to use dP Calculator software on Dresser meters and Romet Calculator software on Romet meters. 6. Record</p>	<p>Octo- ber 15, 2018</p>	<p>Octo- ber 1, 2019</p>

6. G.: Added Romet Differential Calculator

7. Follow-up Action

7. A.: Added Romet Differential Calculator

METR
2.16

Gas Meter Data Sheet

April
1,
2019

Octo-
ber 1,
2019

2. Gas Meter Data Sheet

2. A. (4): Clarified - GMDS is required for any meter index change on any meter regardless of metering pressure.

4. Completion Instructions

4. C. (1) (c): If there is no meter index, this can be noted by entering N/A in the meter reading field.

4. C. (1) (e): "Pressure" replaces "Press"

4. C. (2) (c) 80.: In the removal instructions: If there is no meter index, this can be noted by entering N/A in the meter reading field.

4. C. (2) (d) 82: "removed" replaces "installed"

4. C. (2) (d) 85.: Grammatical correction, added "that was"

4. C. (2) (d) 90.: Added "removed from the installation"

METR
2.20

Meter Header Inspection

Octo-
ber
15,
2018

Octo-
ber 1,
2019

1. General

1. A.: Revised - This procedure describes the inspections and maintenance that should be done at the meter set when performing any work on the meter set.

Clarification that a meter header inspection is to be performed when any work is being done at the meter set not just daily work.

1. B: New - Procedures also addresses the potential hazards and precautions associated with the possibility of induced AC voltage on the meter set.

2. AC Voltage on Meter Set - New section,

3. AC Voltage Action Table - New section

The information previously contained in CORR 2.17 has been moved over to the METR section since it was strictly related to gas meter sets. There was no changes made in the procedures. Reference changes are required throughout the O&M where check meter set with volt stick is mentioned.

4. Inspection/Maintenance When A Meter Set is Not Disassembled.

4. A. (1): Updated the reference link to METR 2.20 A. AC Voltage on Meter Set

- 4. A. (2): Added - Reference link to CORR 1 13. C and D for disbanded coating when check riser.
- 4. A. (3): Reference link to CORR 1 13. C and E for when check for atmospheric corrosion.
- 4. A. (10): Banded regulators with corroded bolts are to be replaced not repaired.
- 5. Inspection/Maintenance When A Meter Set is Disassembled.
- 5. A. (1): Updated the reference link to METR 2.20 A. AC Voltage on Meter Set
- 5. A. (2): Reference link to CORR 1 13. C and D for disbanded coating when check riser.
- 5. A. (3): Reference link to CORR 1 13. C and E for when check for atmospheric corrosion.
- 5. A. (8): Banded regulators with corroded bolts are to be replaced not repaired.

METR 2.24	<p>Replacement of Large Volume Diaphragm Meters</p> <p>Removed 2. Safety section since it the information was all standard work practices for all work performed in AIC.</p> <p>3. Meter and Regulator Inspection</p> <p>3. A.: Updated the reference link to METR 2.20 A. AC Voltage on Meter Set</p> <p>4. Meter Header Inspection - Title change 4. A.: New - Perform a Meter Header inspection in accordance with METR 2.20</p> <p>Removed the listing of items to be checked since they area in METR 2.20</p> <p>10: Leak Check - Title change</p> <p>10. A.: Simplified - Upon completion of the meter replacement; restore gas service to the meter and check the meter set for leaks.</p> <p>Removed bar testing the riser since that is a Missouri requirement not Illinois.</p> <p>11. Painting the Meter Set 11. A.: Simplified - If the above ground piping needs painting, it shall be done in accordance with CORR 1 14. B. (2) and C. Facilities Maintenance and Painting Facilities.</p>	Janu- ary 1, 2018	Octo- ber 1, 2019
METR 2.27	<p>Electronic Corrector Installation Verification</p> <p>Reformatted this section</p> <p>3. Documentation Activities - Title change</p> <p>3. B. Meter Information</p>	Octo- ber 15, 2018	Octo- ber 1, 2019

3. B. (6): Removed "if the meter is temperature compensated", moved to a separate line.

3. B. (7): New - Temperature Compensated box - Record Yes or No.

3. C. Device Programming Verification

3. (1) (c), (d) and (e): New items - % Specific Gravity, % N2 for Supercompressibility and % CO2 for Supercompressibility

3. D. Device Installation Verification 3. D. (1): New- Confirm device is installed properly on the meter or instrument drive. 3.

D. (2): Added a word "Verify" pressure sensing line valve is Open.

3. D. (3): Clarification - Mechanical uncorrected reading should match electronic uncorrected reading.

3. E. Corrector Information

3. E. (3): New - Record corrected serial number

METR 2.29	Gas Meter Bypass 1. General 1. C.: Updated the reference link to METR 2.20 A. AC Voltage on Meter Set	April 1, 2019	October 1, 2019
METR 3.04	Regulator Sizing - 2 PSIG Delivery Pressure Corrected the part number for the spring in the 1" Fisher 289H Relief Valve and the stock code for the 289H.	January 1, 2018	October 1, 2019
METR 3.07	Regulator Sizing - Alternate Approved Corrected the part number for the spring in the 1" Fisher 289H Relief Valve and the stock code for the 289H.	January 1, 2017	October 1, 2019
METR 3.14	425 Meter, By-Pass, 2 and 5 PSIG Delivery Pressure, 5-60 PSIG Inlet In the Material List table, added the Relief Valve Set Pressures for 2 psig delivery and 5 psig delivery since the same relief valve is used. Updated some stock codes.	January 1, 2018	October 1, 2019
METR 3.17	603 Meter, By-Pass, 2, 5 and 10 PSIG Delivery Pressure, 5-60 PSIG Inlet In the Material List table, added the Relief Valve Set Pressures for 2 psig delivery, 5 psig delivery and 10 psig delivery since the same relief valve is used. Corrected the spring color of the 1" Itron CL31N and change Actaris to Itron. Updated some stock codes.	January 1, 2014	October 1, 2019

METR 3.19	15C Compact Meter, 7" W.C. Delivery Pressure In the Material List table updated some stock codes.	January 1, 2018	October 1, 2019
METR 3.20	15C Compact Meter, 2 PSIG. Delivery Pressure In the Material List table updated some stock codes	January 1, 2018	October 1, 2019
METR 3.21	15/3M Meter, 7" W.C. Delivery Pressure In the Material List table updated some stock codes.	January 1, 2018	October 1, 2019
METR 3.22	15/3M Meter, 2 PSIG Delivery Pressure In the Material List table updated some stock codes.	January 1, 2018	October 1, 2019
METR 3.23	15C/3M Meter, 5 & 10 PSIG Delivery Pressure Material List: Expanded table to show material quantities for a 1 inch and a 2 inch riser. Added Relief Valve Set Pressures for 5 psig delivery and 10 psig delivery since same relief valve is used. Updated some stock codes	April 1, 2013	October 1, 2019
METR 3.24	5M/7M Meter, 7" W.C. Delivery Pressure In the Material List table updated some stock codes.	January 1, 2018	October 1, 2019
METR 3.25	5M/7M Meter, 2 PSIG Delivery Pressure In the Material List table updated some stock codes	January 1, 2018	October 1, 2019
METR 3.26	5M/7M Meter, 5 & 10 PSIG Delivery Pressure Material List: Expanded table to show material quantities for a 1 inch and a 2 inch riser. Added Relief Valve Set Pressures for 5 psig delivery and 10 psig delivery since same relief valve is used.	April 1, 2013	October 1, 2019
ODOR 0	Table of Contents ODOR 4: Updated Ameren Shipping Paper - Odorant and Odorant Event Report 1-28-2019 Fillable	April 1, 2019	October 1, 2019
ODOR 4	Forms and Reference Materials ODOR 4: Updated Ameren Shipping Paper - Odorant and Odorant Event Report 1-28-2019 Fillable	April 1, 2019	October 1, 2019

UNCONTROLLED IF PRINTED

POLY 0	Table of Contents New section POLY 2.11 Maintenance of Fusion Equipment	Janu- ary 1, 2019	Octo- ber 1, 2019
POLY 1	Requirements 8. Weak Link 8. B. (1) Installation options for PE pipe sizes less than or equal to 1" CTS:	Feb- ruary 1, 2019	Octo- ber 1, 2019
	<p>Eliminated using 1/2" CTS as a weak link for 1" CTS.</p> <p>Performance Pipe does not recommend using PE pipe as a weak link because it is difficult to determine if the smaller size of PE pipe is really preventing the larger PE pipe from being overstressed.</p> <p>For pipe sizes of 1" CTS or smaller the weak link options in POLY 1 8. are:</p> <ol style="list-style-type: none"> 1. Pull plug, 18" in length, at least one pipe size larger in diameter, or 2. Physically remove 50% of the pipe wall by drilling holes or cutting slots, or 3. Use back reamer/bore head 1" or more larger in diameter than pipe being installed, or 4. Commercially available manufactured weak link. <p>8. B. (2) For PE pipe sizes larger than 1" CTS:</p> <p>Eliminated using the next size smaller PE pipe as a weak link.</p> <p>A manufactured weak link is the only option for PE pipe larger than 1 inch. AIC has approved a couple, Condux which is a mechanical weak link and Cumberland which is manufactured PE pipe weak link.</p> <p>PHMSA's Plastic Pipe Rule requires a weak link method be used when installing PE pipe by trenchless excavation.</p> <p>8. C. (3): Added - listed below for the Condux swivel.</p> <p>8. D. Cumberland Products</p> <p>Added:</p> <p>AIC stock codes for the MDPE weak links, 1" to 8".</p> <p>AIC is now stocking HDPE weak links, 1" to 6"</p>		
POLY 2.02	Squeeze Off 2. Operation 2. O.: Revised - After removal of the squeeze tool, the squeeze off location shall be identified by wrapping the pipe with electrical tape and the pipe not squeezed off again at that location.	Janu- ary 1, 2016	Octo- ber 1, 2019

Combined the previous 2. P. into 2. O. regarding not squeezing the pipe in the same location. Clarified that it after the squeeze tool is removed, that the pipe is not to be squeeze at the same spot. The squeeze tool can be relaxed and re-squeezed during purging.

POLY 2.05	<p>Electrofusion</p> <p>4. Equipment, Weather and Cleanliness Guidelines</p> <p>4. G. Operating temperature ranged - Added a table with the Manufacturers' Operating Temperature Ranges.</p> <p>Reformatted Pipe Preparation, Peeling and Joint Assembly procedures with step by step procedures to replace the charts.</p> <p>Reports from the field indicated the charts were confusing particularly in the Pipe Preparation section. There are no major changes in the procedures.</p>	January 1, 2019	October 1, 2019
POLY 2.11	<p>Maintenance of Fusion Equipment</p> <p>This document prescribes the general maintenance requirements for the equipment utilized in heat fusion of PE pipe. (192.756)</p> <p>2. Electrofusion Equipment Maintenance</p> <p>A. Maintenance work required on Electrofusion processors shall be only performed by the manufacturer's authorized service personnel or service center. See POLY 4 for manufacturers' manuals.</p> <p>Caution: Under no circumstance shall the electrofusion processor enclosure be opened for service in the field by unauthorized personnel.</p> <p>B. Electrofusion processors shall be maintained at intervals that at least meet the requirements contained in Manufacturer's Instructions. Maintenance records will be maintained in Maximo.</p> <p>C. The following inspection should be performed on a regular basis on equipment that is being used:</p> <p>AIC's EF processor are inspected and calibrated by the vendor on prescribed interval that is in Maximo</p> <p>3. Butt Fusion Machine Maintenance</p> <p>A. Manufacturers' detailed maintenance procedures for the McElroy and Connectra machines can be found in POLY 4.</p> <p>B. The following are general maintenance procedures should be performed on a regular basis on equipment that is being:</p> <p>C. The butt fusion machines will have an inspection performed every other year at approximately the same time as the electrofusion processors are inspected. The inspection will be recorded and tracked in Maximo.</p>	New	October 1, 2019

Butt fusion machine manufacturers current do not have a recommended maintenance interval in their instructions. They have maintenance procedures and a checklist. The expectations is the machines should be checked on a regular basis when being used.

4. Peelers

- A. Peelers should be free of dirt and/or any substance which would contaminate the fusion area.
- B. Peeler blades should be inspected for sharpness and damage, replace if necessary.
- C. If applicable, check wheels to ensure they rotate smoothly and have not been damaged. Replace if necessary

5. Clamps

- A. Clamps should be clean.
- B. Clamps should be inspected for damage and replace if necessary.

Peelers and Clamps should be checked each time they are used. There are no plans to enter these tools in Maximo for tracking.

POLY 3.02	<p>Electrofusion Fittings</p> <p>9. Supraflow Tees - New item</p> <p>These are new style of electrofusion PE taping tees designed for side tapping a main. The outlet of the tee is either a parallel or perpendicular and come with a 90 degree elbow and 2 feet pup.</p> <p>Sizes range from 4" x 4" to 8"x 6".</p> <p>The tapping procedures are in TAPS 2.07</p>	Janu- ary 1, 2018	Octo- ber 1, 2019
PRES 2.02	<p>Electronic Recorders</p> <p>3. Calibration of Electronic Recorders</p> <p>3. C.: Maximo replaces Gas Compliance System</p>	Janu- ary 1, 2013	Octo- ber 1, 2019
PRES 2.04	<p>Overpressure Reporting</p> <p>E. The Gas Supervisor should report the following:</p> <p>E. (4): Revised to - Normal operating pressure, MAOP and MEP of system and highest pressure observed exceeding the MEP.</p> <p>Provides clarification on what is expected to be reported. There was confusion on what maximum actual operating pressure meant and the MEP was not initially listed.</p>	April 1, 2019	Octo- ber 1, 2019

PTST 2.01	<p>Leak Test</p> <p>3. Leak Test Duration</p> <p>3. C.: Revised when testing a main segment that consists of different sizes of pipe, the test duration for each size of pipe will be calculated. The total required test duration will be the sum of the calculated durations for each size. The maximum duration remains at 8 hours.</p> <p>Previously, the duration was based on the largest size of pipe for the entire length of the segment being tested. There were complaints that short sections of larger sizes of pipe in a segment was requiring much longer leak test. Example: (Previous: 10' of 4" and 2000' of 2": 20 min for 2100" = 420 Min) vs (Proposed: (20 min + (10min for 2000')) = 220 min)</p> <p>5. Leak Test Records</p> <p>E. (13): Clarification that the temperature of the pipe can be used in the Temperature Factor calculation when there is test pressure fluctuation due to temperature changes.</p> <p>Technically it is the temperature of the test medium or product in the pipe but that temperature is extremely difficult to measure. Temperature of the pipe will provide an indication of temperature change of the product inside the pipe.</p>	April 1, 2019	October 1, 2019
PTST 2.02	<p>Strength Test</p> <p>4. Strength Test Records</p> <p>B. (13) Clarification that the temperature of the pipe can be used in the Temperature Factor calculation when there is test pressure fluctuation due to temperature changes.</p> <p>Technically it is the temperature of the test medium or product in the pipe but that temperature is extremely difficult to measure. Temperature of the pipe will provide an indication of temperature change of the product inside the pipe.</p>	April 1, 2019	October 1, 2019
PUBL 2.02	<p>Liaison with Fire, Police and Public Officials</p> <p>5. Natural Gas Emergency Procedures</p> <p>5. B. (3): Revised 2nd sentence to - Do not operate any electrical switches and leave the door open after exiting as the strike plate may cause a spark. 5. B. (5): New - Check surrounding buildings for potential gas migration and evacuate as necessary. Continue to monitor gas readings as conditions may change or migration expand. Keep Ameren Illinois updated as conditions warrant.</p>	October 15, 2018	October 1, 2019
PURG 2.01	<p>Purging Methods</p> <p>4. Purging of Air with Gas</p> <p>4. C.: Correction - removed the need for a CGI when purging a 2" and smaller service line of air.</p>	April 1, 2019	October 1, 2019

The CGI was inadvertently added with the October 1, 2018 Update. Historically, when purging air from service line, once gas was detected the meter valve was closed and the line was ready to be placed in service. When the CGI was added, contractors installing services were having to purchase CGI's.

5. Purging of Gas with Air During Abandonment

5. D. New The riser being used as the purge point at the site of injection should be checked for zero pressure before introducing the purge medium.

A reminder that if a riser is being used as the injection point to purge gas from a main, that riser must be connected to the main being purged. There have been too many instances where the riser has been connected to live mains.

REGS
2.01

Regulator Station Inspections

April	October 1,
1,	2019
2019	2019

3. Operational Inspection

3. A. Visual Inspection

3. A. (2) New- Perform a visual assessment of all equipment or devices that are critical to safety, gas delivery and system reliability. Anomalies and abnormalities discovered during the visual assessment will be immediately repaired or reported.

3. C Regulator Station with Relief Valve

3. D Passive Monitor Regulator Station

3. E. Working Monitor Regulator Station

In each of the above sections, Lock-up below the gas system's MAOP or MEP(where applicable) replaces "Lock-up when in acceptable range"

Clarification that the relief valves and monitoring regulators are to lock-up below either the gas system's MAOP or MEP depending on the function of the device.

4. Primary Inspection

4. D. (2): Reference to Operational Inspection for regulator lock-up.

4. E.: Word change, identified in Maximo replaces contained in Maximo 4. F.: New - Station filters, drips, strainers and knock-out drums should be checked for reliable service. This may include opening or other techniques.

During both Operational and Primary Inspections, all of the equipment with the regulator station are expected to be checked for proper operation, condition and required maintenance performed.

5. Acoustical Inspection

5. A.: Modified word - A Station not designed to accommodate or support an Operational or Primary regulator station inspection may require Acoustical Inspection.

5. B.: Word changes - verify replaces ascertained and Lock-up replaces operating properly. Added - below the gas system's MAOP

REPR 0	<p>Table of Contents</p> <p>REPR 4 - Added</p> <p>Clock Spring Specs; Installation Manual Clock Spring Coil-Pass Method and Clock Spring Underwater Installation Guide</p>	October 15, 2018	October 1, 2019
REPR 1	<p>Requirements</p> <p>3. High Pressure Distribution and Transmission Pipe Repair</p> <p>3. F.: Expanded encapsulation to include a leak and an abandoned fitting as an approved method of repair.</p> <p>3. M: Encapsulation</p> <p>3. M. (1): Added a leak can be encapsulated with a manufactured fitting such as a line stopper, short stop, save-a-valve nipple.</p> <p>3. M. (1) (a): Requires GTE and Integrity Management to be consulted to determine if encapsulation is acceptable repair option.</p> <p>4. Steel Distribution Pipe Repair</p> <p>4. B.: Removed - Compression couplings, nut follower style, can be used for Make Safe repairs on 2" and smaller distribution pipe.</p> <p>AIC's only approved and stock compression coupling is a 3/4" IPS x 1/2"CTS, Steel x PE. Use of all other compression couplings have been discontinued in AIC operating areas since they did not carry a Category 1 rating for pullout restraint.</p> <p>4. E. (1): Expanded encapsulation to include a leak and an abandoned fitting as an approved method of repair.</p> <p>4. M. Stainless Steel Bolted Leak Clamp</p> <p>Removed - Can be used to contain leakage from minor gouges or corrosion pits.</p> <p>Removed - Consider temporarily reducing the system operating pressure prior to clamp installation.</p> <p>4. O.: Added a leak can be encapsulated with a manufactured fitting such as a line stopper, short stop, save-a-valve nipple.</p>	April 1, 2019	October 1, 2019

Encapsulating a leak with a manufactured rated fitting has historically been an acceptable practice throughout the AIC operating areas. However, for transmission line repairs, Gas Tech Engineering and Integrity Management feel they need to determine if that is an acceptable repair option.

5. PE Pipe Repair

5. A. (1): Corrected - Imperfections and damage must be repaired or removed.

5. A. (2): Removed language about gouges, scratches and other imperfections since the table addresses

REPR 4	Forms and Reference Materials Added Reference Material: Clock Spring Specs Installation Manual Clock Spring Coil-Pass Method Clock Spring Underwater Installation Guide	October 15, 2018	October 1, 2019
SERV 0	Table of Contents SERV 2.03: Added - Placing Service Line with EFV into Operation Added Right Change Bar to SERV 3.01 & SERV 3.02	October 15, 2018	October 1, 2019
SERV 1	Requirements 5. Location 5. E. Typical location to avoid 5. E. (1) (e): New- Where venting gas will not accumulate. Added as a reminder the regulator relief vents must be able to vent freely to the atmosphere. 10. New Service Lines Not In Use 10. A.: Revised- Each service line not placed in service upon completion shall have the meter valve closed and locked. 10. B.: Expanded the reference link to TURN 2.01 3. New Service Connect. Removed the ability to install a mechanical device of fitting that will prevent flow of gas. Removed disconnecting the customer's piping from the gas supply. The meter valve has to be shut-off and locked so that the customer or any other non-authorized individual cannot initiate gas service by opening the meter valve.	February 1, 2019	October 1, 2019

SERV 2.02	<p>Excess Flow Valve or Manual Shut-Off Valve</p> <p>2. Residential Service Requirements</p> <p>2. A. Single family or branch service lines:</p> <p>2. A. (5): New - If the meter capacity is greater than 1,000 SCFH and a properly sized EFV is not available and stock by AIC, a manual service line shut-off valve is required.</p> <p style="color: red;">Since AIC stocks 1" EFV's capable of handling over 2,000 SCFH and 2" EFV's capable of over 3,000 SCFH, this should not be an issue for AIC. However, our O&M Rewrite Consultants pointed out that since Part 192.365 has this requirement, they recommended including it in the O&M.</p> <p>8. G. EFV Sizing Tables</p> <p>8. G. (3): Added - 2"IPS UMAC Series 2300 EFV</p> <p>8. G. (5): New - Reduced Coupling with EF for Meter Upgrades - Friastop 1" CTS x 1/2" CTS.</p> <p style="color: red;">These EFV are primarily for use with meter upgrades where from a AC 250 to a AL 425. This EFV is based on the customer's connected load not the meter rated capacity.</p> <p>9. EFV and Manual Shut-Off Valve Identification</p> <p>9. A. (2): Removed at the residence. EFV tags are to be place on all meter sets regardless if they are a residential or commercial.</p> <p>11. Placing Service Line with EFV into Operation - New</p> <p>This sections provides the instruction for performing a functional flow test prior to placing the service line into operation.</p> <p>A. Once the service line and meter set riser are installed, pressure tested, and purged, perform a functional flow test through the meter valve to ensure EFV will operate properly:</p> <p><i>Note: If EFV is not actuated, replace the EFV and repeat functional flow test. Ensure properly sized EFV is being installed.</i></p> <p>B. Following a successful functional test, the service line is ready to be placed in service:</p> <p style="color: red;">The EFV manufacturers include a function flow test in their instructions.</p>	April 30, 2018	Octo- ber 1, 2019
SERV 2.08	<p>Insertion</p> <p>4. Dead Insertion Procedures</p> <p>4. E.: New - Remove existing service line valve in the existing steel service line.</p>	Janu- ary 1, 2018	Octo- ber 1, 2019

Since removal of existing valves was included in the main insertion procedures, the recommendation was to include it service line insertion procedures.

SERV 3.01 and	1/2" PE Service Line, Flex Riser & Rigid Riser Effective January 1, 2020, these standards will be used for insertion, repair or replacement of existing 1/2" PE services	April 1, 2013	October 1, 2019
SERV 3.02	Effective January 1, 2020, 1" PE will be the standard residential service. SERV 3.03 and 3.04		
SERV 3.07	Farm Tap, Double Cut, 451 - 1000 PSIG Inlet Pressure Updated stock codes for: Item 7 - 3/4" Street Elbow Item 12 - 3/4" x 2" Nipple, Schedule 80 Item 22 - 3/4" x 6" Nipple, Schedule 80 Items have been combined with another stock code.	January 1, 2018	October 1, 2019
SERV 3.08	Farm Tap, Double Cut, DOT Transmission B. Replaced the Assembly #3 drawings. Item numbers for the valve assembly was corrected. Updated stock codes for: Item 7 - 3/4" Street Elbow Item 12 - 3/4" x 2" Nipple, Schedule 80 Item 22 - 3/4" x 6" Nipple, Schedule 80 Items have been combined with another stock code.	April 1, 2019	October 1, 2019
STLP 2.01	Design Pressure 8. Dual Coat Steel Pipe 8. A.: Revised - Dual coated pipe shall be coated with Fusion Bonded Epoxy (FBE) with and an Abrasive Resistant Overlay (ARO) in accordance with CORR 2.03 1. A. (2) - Directional Drilling Installation Rewritten to referenced CORR 2.03 which contains the mill coating requirements for dual coated pipe rather repeat the coating thickness.	October 15, 2018	October 1, 2019
STLP 2.02	Casing Pipe Installation 1. General 1. C.: Added - PE as another carrier pipe. 3. Casing Installation	January 1, 2016	October 1, 2019

3. B.: Revised - Bare steel pipe is recommended for casing pipe but steel pipe with old coating can also be used.

3. C.: Revised - Pipe insulators for steel carrier pipe shall be spaced a minimum of every 10 feet and a maximum of 3 feet from the ends of the casing. Added "for steel carrier pipe.

STLP 3.03	<p>Weld Transition Fittings</p> <p>1. General</p> <p>1. B.: Revised - When a transition taper is required in the pipe and/or fitting, it shall be made using a mechanical end preparation machine or by manual preparation.</p> <p style="color: red;">Gas Tech Engineering pointed out inconsistency between WELD 2.03 8. F. and the previous language in STLP 3.03. The WELD section had been revised to allow for both mechanical end preparation and manual preparation. Since this Standard is for transition fittings, it was felt that the language from the WELD section should be located in the STLP section. The WELD 2.03 8. F. now has a reference link to STLP 3.03.</p>	<p>April 1, 2010</p>	<p>Octo- ber 1, 2019</p>
TAPS 0	<p>Table of Contents</p> <p>TAPS 2.04 - Added 5. Stopple Fittings</p> <p>Added - TAPS 2.07 Supraflow Tee Tapping Procedures</p> <p>TAPS 4 - Forms and Reference Materials</p> <p>Added 2 new References: GFCP Punch Tee with Transition and Style 2275 Dresser Stop Changer Manual</p>	<p>Janu- ary 1, 2016</p>	<p>Octo- ber 1, 2019</p>
TAPS 1	<p>Requirements</p> <p>1. Objective</p> <p>1. A.: Added - on steel lines.</p> <p>1. B.: Added - and contractor personnel.</p> <p>The purpose of this section is to provide necessary information to ensure personnel perform tapping and stopping procedures on steel lines in a safe and efficient manner.</p> <p>1. D.: Added (AIC)</p> <p>1. G.: Revised - A Tapping Request Form is required for each hot tap and/or stopping operation to be performed by contractor, Gas Tech Service personnel or AIC personnel from another Operating Area on all sizes of steel transmission and high pressure distribution pipelines, or 2 inch and larger distribution pipelines.</p> <p>Along with contractors and Gas Tech Services personnel, AIC personnel from outside the Operating Area can be scheduled to perform tapping and stopping operations on steel pipe, live or dead, Construction Services felt that a Tapping Request Form should be completed for taps/stops on steel pipe. This</p>	<p>April 1, 2019</p>	<p>Octo- ber 1, 2019</p>

would ensure the correct equipment and fittings were being brought to the project.

6. Fitting Placement

6. B.: A tap shall not made through any girth welds. Removed longitudinal seam from this restriction.

6. C.: New - If a tap is going through an known longitudinal seam, an analysis of the seam is to be performed in accordance with WELD 2.04 4. D. (6).

6. E. New - Checking for pipe wall lamination in Transmission lines and 4 inch and larger high pressure steel distribution mains with MAOP of 100 psig or greater is covered in WELD 2.04 6. B.

Gas Tech Engineering and Integrity Management personnel felt these additional requirement were necessary to ensure the integrity of the pipe prior to welding on a fitting and tapping the pipe.

6. D.: Revised - Transmission lines should be checked for laminations prior to installing a control fitting. Removed the 12 inch and larger requirement.

Gas Tech Engineering and Integrity Management engineers along with the Supv Gas Tech Tng - Welding felt that a check for laminations be performed on all sizes of transmission lines, not just those 12" and larger, prior to welding on a control fitting. This would be performed with an ultrasonic wall thickness (UT) gauge as specified in In-Service Welding.

7. Gauge, Blow-down, By-pass Fittings

7. B. (3): Added - leak detection instrument

TAPS
2.04

T.D. Williamson Tapping and Stopping Procedure

January 1,
2012 October 1,
2019

2. Tapping Operation

2. J.: Removed - Pressure test tapping equipment and valve.

Gas Superintendents said as far as they know or have experienced, this has never been done on TDW equipment.

5. Stopple Fitting - New

AIC now stocks Stopple fittings for 8" and 10" steel lines.

Reference added to TAPS 4 that contains TDW Hot Tapping and Stopple Pipe Plugging.

TAPS
2.07

Supraflow Tee Tapping Procedures - New Section

New October 1,
2019

Procedures were prepared by Gas Training and Gas Standards personnel based on Torre's video and practice demonstrations at the Training Center.

The bore machine drill rod actually attaches to the drill head in the tee. Tapping machine has color coded drill rods which correspond to colors on the Supraflow Tee drilling head.

TAPS 3.01	<p>Mueller Fittings</p> <p>3. Line Stopper Fittings</p> <p>Removing the 2" H-17155 (250 psig) and 2" H-17156 (1,440 psig)</p> <p>4. Mueller Bottom-Out Line Stopper Fittings</p> <p>Removing 2" H-17161 (1,440 psig)</p> <p>Gas Tech Services had requested that AIC standardize on one model of 2" line stopper fitting. Currently AIC has 2 different styles of Mueller Line Stoppers. One has a steel completion plug with an O-ring. The other is a steel completion plug without the O-ring. GTS Supt said they have been experience problems installing the completion plug on the models without the O-ring. GTS Supt checked with the Operating Areas and the preferred model was the one with the O-rings. The areas all have the equipment 2" H-17125 and H-17126 fittings. Standards & Material group agreed and the above Mueller line stoppers are being discontinued in Stores.</p>	April 1, 2019	October 1, 2019
TAPS 4	<p>Forms and Reference Materials</p> <p>Added:</p> <p>Ref 22 - GFCP Punch Tee with Transition</p> <p>Re 23 - Style 2275 Dresser Stop Changer Manual</p>	January 1, 2016	October 1, 2019
TURN 0	<p>Table of Contents</p> <p>Removed TURN 2.12 Defective Equipment</p>	January 1, 2018	October 1, 2019
TURN 2.01	<p>Residential - Small Commercial Customer</p> <p>3. New Service Connect</p> <p>3. B.: Revise- A gas meter should be installed at the same time as the service as long as the structure is framed out, the outlet of the meter bar should have:</p> <p>3. B. (1): A closed customer valve installed and the meter valve left in the on position, or</p> <p>3. B. (2): If a customer valve is not installed, the meter valve shall be locked in the off position.</p> <p>4. Existing Service Connect</p> <p>4. A.: Revised - Updated reference link to METR 2.20 2. AC Voltage on Meter Set.</p> <p>4. E. Customer Choice - Customer Relight Appliances</p>	October 15, 2018	October 1, 2019

4. E. Customer Choice - Customer Relight Appliances

(1) Customer is at home and shut-in test passes: (a) Leave meter valve in the on position

(b) Notify customer gas is on and ready for use (2) Customer is at home but shut-in test fails (a) Perform an investigation to determine location of leak

(b) Isolate the leak per LEAK 2.01 6. Leaks on Customer Facilities

(c) Notify the customer of the source of the leak and that they are responsible for repair (d) If the leak is isolated at the valve downstream of the meter outlet or at the appliance control valve, leave the meter valve in the on position, and give customer a Meter Relight Tag. (3) If customer is not at home or unavailable: (a) Perform a low flow test and 5 minute shut-in test on customer piping, if successful

- If there is a valve downstream of the meter bar, turn off the valve and leave a Meter Relight Tag, or
- If possible, install a customer valve downstream of meter bar, leave valve in off position and leave a Meter Relight Tag, or
- If valve does not exist, turn off and lock the meter valve. Leave a door hanger advising the customer to call and reschedule.

(b) If shut-in test fails, turn off and lock the meter valve. Leave a door hanger advising the customer to call and reschedule.

Procedures were revised to reflect a change in policy where the customer can no longer operate our meter valve to turn on the gas supply to their piping/appliances. If the low flow test and shut-in test are successful and there is a valve downstream of the meter outlet, that valve can be operated by the customer and AIC's meter valve can be left in the on position.

5. Low Flow and Five (5) Minute Shut-In Test

5. A.: Added - two words, verbally and immediately. If odorant is not readily detectable, verbally notify Gas Supervisor immediately for a follow-up investigation. See ODOR 2.03 6. Odorant Intensity Testing Sniff Test.

It is important that gas be readily detectable at the customer's service. If it isn't, immediate action needs to be taken to determine why.

5. E.: Revised - Check meter set fittings for leaks and repair any leaks found.

Changed language from Soap meter set fittings and repair any leaks found. Leaks can be checked with leak detection instrument. If leak detection fluid is used, it makes it more difficult to paint the meter set.

12. Gas Meter Relight Tag

12. B.: Revised - The Gas Meter Relight Tag provides the customer with instructions on how they can turn on their gas at the valve downstream of the meter outlet.

The instructions have been changed to show how to turn on the valve downstream of the meter set not the meter valve.

12. C.: Updated the Relight Tag that was revised 8/19 which provides instructions for operating the customer valve downstream of meter outlet.

TURN 2.03	<p>Discontinuance or Transfer of Gas Service</p> <p>4. Hard Disconnect (Terminate Service)</p> <p>4. C.: Updated reference link to METR 2.20 2. AC Voltage on Meter Set</p> <p>4. F.: The only option now is to close and lock the meter valve. Removed physically disconnecting the customer piping and closing the ends with a cap, plug or flange.</p>	January 1, 2018	October 1, 2019
TURN 2.10	<p>Corrugated Stainless Steel Tubing</p> <p>1. General</p> <p>1. C.: Revised - The polyethylene jacket should be left on the CSST for the length of penetration through metal, masonry or concrete to provide a sleeve to protect the integrity of the pipe.</p> <p>According to the CSST manufacturers, the polyethylene jacket is to be left on through the penetration of the foundation wall, up to the termination plate, to protect the integrity of the pipe.</p>	January 1, 2018	October 1, 2019
TURN 2.11	<p>Warning Tag</p> <p>4. Isolating an Appliance</p> <p>4. A.: Revised - Gas field personnel may isolate a hazardous condition at the at the appliance control valve, customer owned valve, or by shutting off and locking, Red Pin, the meter valve.</p> <p>4. B.: Removed - Since disconnect/cap at meter set outlet or plug/cap outlet of meter are no longer applicable.</p> <p>If the appliance cannot be isolated at the appliance control valve or customer valve, AIC's meter valve has to left in the off position and locked.</p>	January 1, 2016	October 1, 2019
TURN 2.12	<p>Defective Equipment</p> <p>Removed this section</p> <p>There is not a good method of updating defective equipment and it should be the responsibility of HVAC dealers and the media to keep customers aware of defective equipment.</p>	January 1, 2011	October 1, 2019

TURN 2.14	<p>Changing Meter Valves</p> <p>Changing of Meter Valves "On-The-Fly"</p> <p>E. (5).: Revised - Gas field personnel at the job site shall wear Level 1 PPE as a precaution due to the exposure to gas associated with changing a valve "on the fly". See WWBG 2.02 Personal Protective Equipment.</p> <p>Replaced listing the Level 1 PPE items added a reference link to WWBG 2.02 which list the approved PPE for Level 1 and Level 2.</p>	Janu- ary 1, 2016	Octo- ber 1, 2019
WELD 0	<p>Forms and Reference Materials</p> <p>WELD 4: Added - DeFelske PosiTector UTG Full Guide</p>	April 1, 2019	Octo- ber 1, 2019
WELD 1	<p>Requirements</p> <p>Throughout this document the words Examination and Inspection have been changed to Testing.</p> <p>Radiographic Testing, Dry Magnetic Particle Testing, Liquid Penetrant Testing.</p>	Janu- ary 1, 2016	Octo- ber 1, 2019
WELD 2.02	<p>Welder Performance Qualifications</p> <p>Throughout the document AIC replaces Ameren Illinois.</p> <p>Throughout the document Supv Gas Tech Tng - Welding replaced Gas Trainer - Welding</p> <p>5. Qualification Categories (Initial Test)</p> <p>5. E.: In-Service Welding Test</p> <p>5. E. (4): New - Branch-on fitting (full penetration groove weld with fillet reinforcement); 12 inch nominal diameter, 0.250 inch minimum wall thickness in 5F position, run pipe horizontal with branch out the side.</p> <p>Supv Gas Tech Tng - Welding is replacing the test sleeve and fitting places at the 45 degree position with this new procedure. This will qualify an in-service welder to weld on any size of pipe.</p> <p>8. Welder Re-Qualification</p> <p>8. C. Six month requalification test table:</p> <p>Supv Gas Tech Tng - Welding will select the pipe size to be used for the butt weld test each year. All of the welders will re-qualify on the same size pipe during that year.</p> <p>8. E.: In-Service Welders (Annual and 8 month Requalification)</p> <p>8. E. (1): Revised - The Annual and 6 month requalification test requirements will be at the discretion of the AIC Supv Gas Tech Tng - Welding and will meet the essential variables of API 1104, Appendix B.</p>	Janu- ary 1, 2016	Octo- ber 1, 2019

Supv Gas Tech Tng - Welding has requested the ability to determine the testing requirements based on the essential variables in API 1104, Appendix B. The testing will be the same for all In-Service welders for that year.

WELD 2.03	<p>Construction of Pipelines and Piping Systems</p> <p>8. Welding Requirements</p> <p>8. F. Transition Joints</p> <p>8. F. (1): Revised - Fabricated weld transition fitting replaces pre-fabricated weld transition fitting.</p> <p>8. F. (2): Moved to STLP 3.03 Weld Transition Fittings</p> <p>8. N. Weld Pass Requirements</p> <p>8. N. (4): New - . Maximum time for unfinished welds should be as soon as possible, not to exceed seventy two (72) hours.</p> <p>API 1104 requires the procedures to provide a time between welds. AIC's welding consultant recommended a maximum time of 72 hours to finish a weld.</p> <p>9. Inspection of Welds</p> <p>9. A. Recommended Non-Destructive Testing Methods (NDT)</p> <p>9. A. (2) Chart: Revised NDT method for fillet welds, Recommend method is Magnetic Particle Testing (MPT) with Liquid Penetrant Testing (LPT) as an Alternative.</p> <p>Supv Gas Tech Tng - Welding based this on industry practices.</p>	Janu- ary 1, 2018	Octo- ber 1, 2019
WELD 2.04	<p>In-Service Welding</p> <p>Throughout the document AIC replaces Ameren Illinois.</p> <p>4. Acceptable Repair Methods</p> <p>4. D. Hot Tap Fittings</p> <p>4. D. (6): Revised - If the tap is through an area containing a longitudinal seam on all transmission pipe or 4" and larger high pressure distribution pipe with MAOP of 100 psig or greater, the area shall be ultrasonically analyzed for a distance of 10 inches beyond the fillet weld at the ends of the fitting. -</p> <p>4. D. (7): Revised - All hot tap fittings and other pressure containment fittings shall be leak tested in accordance with PTST 1 5. Testing procedures after completion of the welding, but before cutting the hot tap.</p> <p>4. D. (7): Removed leak test language since it is covered in PTST 1 5. Testing.</p> <p>6. Welding Procedures</p> <p>6. B. Wall Thickness Survey</p>	Janu- ary 1, 2018	Octo- ber 1, 2019

6. B. (1): New - Prior to any in-service welding or installation of a fitting to be used to tap a transmission line, the area to be welded shall be (UT) tested for laminations, internal corrosion, inclusions. Etc. See WELD 2.09 Ultrasonic Wall Thickness Examination

6. B. (2): New - Prior to any in-service welding or installation of a fitting to be used to tap a 4 inch and larger high pressure steel distribution mains with MAOP of 100 psig or greater should be (UT) tested for laminations internal corrosion, inclusions. Etc. See WELD 2.09 Ultrasonic Wall Thickness Examination

6. B. (3): Updated - In order to weld on a 4 inch and larger pipe, the minimum wall thickness must be 0.188 inches unless approved by the Company Weld.

Gas Tech Engineering, Integrity Management and Supv Gas Tech Training - Welding agreed that the all transmission pipe must be checked for lamination prior to welding on a tapping fitting. This is a standard practice in the industry for transmission lines. It is also recommended for 4 inch and larger high pressure distribution pipe.

After discussions with industry welding experts, the Supv Gas Tech Training - Welding indicated that the minimum wall thickness of 0.188 inches applies to 4 inch and larger pipe.

6. D. Welding Sequence

Throughout this section UT survey replaces wall thickness survey.

6. D. (1): AIC designated welding supervisor replaces the company welder as the one who would have to approve welding on pipe with wall thickness less than 0.188".

6. D. (11): WELD 2.07 Magnetic Particle Testing and WELD 2.08 Liquid Penetrant Testing replaces MPT and LPT.

8. Inspection Requirements

8. A. (1): LPT replaces Liquid Penetrant and added Liquid Penetrant Testing to WELD 2.08

8. A. (2): MPT replaces Magnetic Particle Inspection and added Magnetic Particle Testing to WELD 2.07.

WELD 2.06

Radiographic Testing

Throughout this document AIC replaces Ameren Illinois.

5. Radiographic Testing Procedures

5. A. (3): New - Required radiographic testing of welds shall be performed on pipe that is uncovered, accessible and not coated with any material that would interfere with the radiographic testing.

January 17, 2018
October 1, 2019

Supv Gas Tech Training - Welding requested adding API 1104 language regarding the condition of the pipe prior to performing radiographic testing.

5. B. Procedure Qualification

5. B. (2) (b): New - Any changes in details contained in API 1104 Section 11.1.2.2 Film Radiography (20th Edition), requires a new procedure shot. Details may include: List of details included

Supv Gas Tech Training - Welding requested adding API 1104 language which stipulates when a new procedural shot is required.

WELD 2.09	<p>Ultrasonic Wall Thickness Examination</p> <p>Throughout this document AIC replaces Ameren Illinois.</p> <p>2. Equipment and Materials</p> <p>2. B.: New - AIC uses a DeFelske PosiTector UTG. See WELD 4 for the DeFelske Full Guide manual.</p>	April 1, 2012	October 1, 2019
WELD 4	<p>Forms and Reference Materials</p> <p>Added: DeFelske PostTector UTG Full Guide</p>	April 1, 2019	October 1, 2019
WWBG 2.01	<p>Hazardous Atmosphere</p> <p>4. Working in a Hazardous Outdoor Atmosphere</p> <p>4. B.: Changed "should" to "shall". Gas field personnel shall always explore all available options to control blowing gas, whenever possible, and make the repairs in a gas free atmosphere.</p>	January 1, 2018	October 1, 2019
WWBG 2.02	<p>Personal Protective Equipment</p> <p>1. E. Chart: Level 2 Silver Needle Ensemble now requires a Level 1 coverall to be worn under the Level 2 insulated coveralls.</p> <p>Silver Needle Level 1 coveralls have been added as an approved item.</p> <p>Jeff Lott, Sr. Safety Supv, presented burn test data to the WW-BG SMR Team, Tim Jacobs, facilitator. Burn test results for the Silver Needle Level 2 showed an individual would get 20% 2nd degree burns. If a second layer of protection was provide under the Level 2, there would be a significant reduction in 2nd degree burns. The SMR Team agreed from a safety standpoint there is no question that a Level 1 suit should be worn under the Silver Needle Level 2 suit.</p> <p>Jeff informed the team, that Silver Needle now has a Level 1 coverall which he recommends be added to the approved list and entered on the Chart.</p>	October 15, 2018	October 1, 2019

Supersedes: April 1, 2019

CHANGE SUMMARY
Change Summary April 1, 2019

April 1, 2019

Document	Change Summary
Major Changes in this Update	
ABND 1 ACIG 1 ACIG 2.01 REPR 1	<p>In these sections, the need to turn off rectifiers prior to welding on the steel pipe has been removed.</p> <p>However, bonding of the steel pipe prior to cutting is required and that bond shall remain in place until the pipe has been reconnected.</p> <p><i>Documentation from welding supply company and from the National Association of Corrosion Engineers (NACE) indicates that rectifiers do not have an effect on welding nor does rectifier voltage create a safety hazards.</i></p>
CORR 2.03	<p>Pipe Coating Repair and Fitting Coating Repair:</p> <p>When the coating repair is performed with the 2 part liquid epoxy, the repair shall extend a minimum of 1 inch beyond the edge of the defect. This was reduced from 6 inches.</p> <p><i>Denso Protal instructions specifies extending the repair a minimum of 1 inch beyond the defect.</i></p> <p>Soil to Air Interface Zone:</p> <p>The UV Protection coating is to extend up above final grade.</p> <p><i>A change from 12 inches above grade or to bottom of the valve whichever comes first. The O&M Approval Committee felt the UV wrap just need to come above the final grade</i></p> <p>Approved Cold Applied Tape</p> <p>Removed the TC Profile Putty from the approved list.</p> <p><i>Tapecoat has put an expiration date on this product. Since it is not used on a regular basis, this would increase the potential for using a product that is past its expiration date or increase the amount of material that has to be disposed.</i></p>
CORR 2.32	<p>Added the new Protal 7300 product that is specially formulated for application on dry, damp or wet surfaces when the pipe surface temperature is 32°F or warmer.</p>
<u>MAIN 1</u>	<p>In the Location section, main shall not be installed under buildings. This includes a new, relocated or replaced main.</p> <p><i>The SERV section included language that services were not to be installed under buildings but there wasn't a similar restriction for mains. This same restriction should apply to mains. Approval Committee agreed with that position.</i></p>
MAIN 2.02	<p>Lowering or Realignment of Pipe</p> <p>Section has been expanded to include:</p> <p>Information on which engineering group is responsible for determining the feasibility of safely lowering or realigning pipe.</p>

UNCONTROLLED IF PRINTED

What should be included in the Engineering Review.

Inspections to be performed prior to and after movement.

Minimum Strip Back Distance table has been revised. The table only applies to pipe with MAOP of 60 psig or less. Gas Tech Engineering will determine the minimum strip back distance for the higher pressure pipe.

Additional information, concerns and guidance are a result of an engineering review of API RP 1171 Manual Movement of In-Service Pipelines.

MAIN
2.04

Temporary Pipeline Support Methods

Section has been expanded to include:

Information on which engineering group is responsible for determining the temporary support method.

A couple of additional support methods are shown.

MAIN
2.06

Insertion

If there is an existing valve installed on the casing pipe that has been or being inserted, that valve shall be removed or made inoperable.

This to eliminate the possibility of someone operating the valve and potentially cutting the insert pipe creating a hazardous leak.

METR
2.29

New Section: Gas Meter Bypass

This sections contains procedures for two methods that can be used to bypassing the gas meter without interrupting the service to the customer. Bypassing the meter can be utilized for any activity that requires shutting off the gas to the service line.

Portable CNG Tank System with Angled System Bypass Valve

Portable CNG Tank with Grunsky Apparatus

PMRK
3.04

A new pipeline marker sign has been added that can be used for regulator station signage as well as for pipeline marking.

The new sign contains "No Smoking" and can be used in lieu of the Regulator Station signs in PMRK 3.03. This eliminates the need for two signs at a regulator station or farm tap.

PRES
2.03

Potential Over Pressurization or Service Interruption

Pressure monitoring is required when replacement work or regulator station maintenance work affects a low pressure distribution system.

An Operational Checklist is required with tapping/stopping on low pressure distribution mains if being performed.

A listing of AIC's low pressure systems has been added.

There is to be a pre-job meeting prior to work being performed on any activity which requires an Operational Checklist and Written procedures.

Additional precautionary steps were needed when performing any activity which could potentially affect a low pressure distribution gas system. This became ap-

parent following a review of our O&M in-light of the aftermath of Boston area explosions.

PRES
2.04

Overpressure Reporting

Additional information that must be provided to Gas Compliance when the pressure exceeds the Maximum Emergency Pressure of a system is listed.

The additional information is needed for the required notification to PHMSA and the ICC.

PTST 1

When pipe is being used for bypassing through stopping machines, the pipe has to be pre-tested to at least 1.5 times the maximum pressure encountered during the operation.

Pipe is does not carry a pressure rating as does hydraulic hoses. The Code requires pipe to be pressure tested to 1.5 times the maximum pressure.

Digital pressure gauges should be read and recorded in whole units, rounded down the nearest whole unit.

Process gauges are spring gauges in which small fluctuation in pressure would normally not be noticed. Whereas, any small fluctuation in pressure is easily notices on a digital gauge. As a result a small fizzer leak on a test tree would in all likelihood not be noticed on a spring gauge but would be on a digital gauge.

When the required pressure test for a bottom-out line stopper assembly exceeds the collapse pressure of the carrier pipe, a reference to TAPS 1 8. which has fabricating and testing procedures.

PTST
2.01

Leak Test and Strength Test

Same statement has been added to these two sections.

and

Fluctuation shall be documented in the Comments sections on the pressure test stamp. Refer to PTST 1 3. A. (2) (d) if recording device has a digital display.

PTST
2.02

Provided instructions as to where pressure fluctuation is to be documented and the reference to PTST 1 3. provides instructions that the pressure is recorded on whole units

METR
3.01

3. Standardized Design Features

3. D. (3) New, Installation of below grade control lines should be minimized whenever possible.

3. D. (4) Additional requirements for below grade control lines; control lines should be separated, Buried Gas Pipeline Caution Tape installed over the control lines and control lines should be documented on as-built prints.

These revision were added to provide additional protection against excavation damage and to ensure location of below grade control lines are recorded. Concerns for below grade control lines are a result of the recent explosions in the Boston area.

3. J. Revised, Inlet and outlet steel risers shall be coated in accordance with CORR 2.03 1. F. - Soil to Air Interface Zone.

Eliminated stating the actual height above the surface that the risers should be coated. That is covered in CORR 2.03 1. F.

3. L. & M. New, these two sections address the protection of above ground regulator stations against accidental damage by vehicular traffic. 3. M. provides factors to be taken when determining if the regulator station is a safe distance from vehicular traffic.

3. N. Expanded the issues that need to be considered for the need of security fencing around an above ground regulator station to prevent unauthorized entry.

The SMR team was requested to develop additional guidelines and procedures for addressing how to protect above ground regulator stations from vehicular damage and unauthorized entry. Steve Blunier with GTE assisted in the development of this revision. This language is necessary to clear a NOA issued by the ICC.

TAPS 1 Under 8. Testing, there are detailed fabrication and testing instructions for bottom-out line stopper assemblies when the test pressure could collapse the carrier pipe.

Gas Tech Engineering and Welding Trainer developed the plan in order to provide a standard methodology which would ensure the assembly would comply with pressure testing requirements.

Document	Complete Change Summary	Previous Document Dated	Current Document Dated
ABND 0	Table of Contents ABND 4 Added Form 01 - Purge Stamp Reference 03 - Polywater AFT Sealant	October 15, 2018	April 1, 2019
ABND 1	Requirements 2. Planning 2. B. (4): Deleted " or need for rectifier to be turned off" <i>Documentation from Lincoln Welding and NACE indicate that a rectifier does not affect welding nor is it a source of accidental ignition so this consideration in the planning phase is unnecessary.</i>	January 1, 2018	April 1, 2019
ABND 4	Forms and Reference Materials ABND 4 Added: Form 01 - Purge Stamp	January 1, 2018	April 1, 2019

Reference 03 - Polywater AFT Sealant

ACIG 1	<p>Requirements</p> <p>2. Sources of Ignition</p> <p>2. D.: Expanded: "An electric bond shall always be installed prior to cutting steel gas pipe. Maintain the bond until the pipe has been reconnected to eliminate the potential of arcing."</p> <p><i>Emphasize the importance of installing bond cable to eliminate the potential for arcing across the pipe separation.</i></p> <p>2. F.: Removed "Rectifiers" as a source of ignition.</p> <p><i>A NACE publication explained that the rectifier DC voltage is typically between 1.0 and 3.0 VDC which is not a safety hazard nor a source of ignition.</i></p>	<p>January 1, 2018</p>	<p>April 1, 2019</p>
ACIG 2.01	<p>Work Area Protection</p> <p>2. Tools and Equipment</p> <p>2. F.: Removed "Rectifiers should be turned off prior to cutting or separating the pipe under cathodic protection."</p> <p><i>A NACE publication explained that the rectifier DC voltage is typically between 1.0 and 3.0 VDC which is not a safety hazard nor a source of ignition. Arcing across separated pipe is the potential source of ignition which is eliminated by installing a bond cable prior to cutting the pipe.</i></p>	<p>January 1, 2018</p>	<p>April 1, 2019</p>
APPR 2.01	<p>Gas Journeyman</p> <p>2. Gas journeyman Training Curriculum</p> <p>2. C. Title change to PE Joining (Session #1100) from PE Mains and Services</p> <p>2. H. Direct Operated Regulator and Reliefs, Customer Meters (Session #1500)</p> <p>2. H. (7) Added Odorant Intensity Training</p> <p>2. I. Leak Investigation</p> <p>Added Gas Detection Instruments, Gas Leaks and Migration, Leak Investigation and DIMP.</p> <p>Removed FI Units, CGI, Ethane Identifier, Odorant Intensity Testing, Outside Leak Investigation and Inside Leak Investigation.</p> <p>2. J. Customer Premise (Session #3200)</p> <p>Added Leak Investigations on Customer Equipment and Carbon Monoxide.</p> <p>Removed Pressure Checks, Low flow and shut-in tests, Turn-On, Turn-Off and Meter Valve Changing</p>	<p>January 1, 2016</p>	<p>April 1, 2019</p>

2. K. Changed title, Construction & Maintenance of Distribution System (Session #2000) from Steel Mains and Services

2. K. (1) & (3) Added Plastic Pipe

2. K (10) Added Documentation

5. (OJT) Breakdown by Type of Work with Associated B31Q Covered Task

Under Steel Installation, ten (10) new work types were added.

6. Gas Apprentice Performance Appraisal

Revised the instruction for reviewing the performance appraisal. The appraisal form should be discussed with the apprentice each month. The performance appraisal form must be submitted to the union as well as the Gas Training Center staff.

7. Gas Apprentice Session Evaluation

7. C. Added, Communicate observations of apprentice's behavior and performance while in training.

Updated the example of a Gas Apprentice Session Evaluation form.

8. Home Study Guide

8. B. Revised to include Reading Assignments and Activity Sheets covering the Home Study/Home Reading Assignments.

8. C. The passing grade of 80% includes all exercises, exams and activities.

Gas Training personnel updated the Gas Journeyman training to reflect a reorganization of and changes in of topics covered in some of the sessions. Also revised some of the instructions and expectations for the performance review and Home Study Courses. The Gas Apprentice Session Evaluation Forms have been updated to reflect the change in topics. The trainers will review this updated version of APPR 2.01 with the apprentices.

CORR 0	Table of Contents	October 15, 2018	April 1, 2019
	CORR 2.32 Protal 7300 - New Section		
	CORR 3.16 AC Stray Test Station - Revised		
	CORR 4 Forms and Reference Materials		
	Added: Eight (8) new reference materials		
CORR 1	Requirements	February 1, 2019	April 1, 2019
	3. Corrective Action		
	3. C. Unmonitored steel mains replaces Unmonitored pipe.		

Clarifies that if the P/S reading on unmonitored steel mains where does not meet AIC's criteria, Maximo creates an integrity leak surveys. Maximo does not create leak survey for Unmonitored steel services/risers. When unmonitored steel services/risers are discovered they are scheduled to be replace within 12 months.

CORR 2.03	<p>Coatings</p> <p>1. Approved Coatings</p> <p>1. C. Coating Repair</p> <p>1. C. (1) Pipe Coating Repair and</p> <p>1. C. (2) Fitting Coating Repair</p> <p>In the table:</p> <p>"circumference" replaces "diameter"</p> <p><i>Incorrect term was initially used.</i></p> <p>FBE repair with 2 part liquid epoxy: repair should extend at least a minimum of 1 inches beyond edge of defect. Reduced from 6 inches.</p> <p><i>Denso's repair procedures say to extend a minimum of 1 inch beyond edge of defect. Repairs were becoming more costly and time consuming on large project pipeline deliveries when contractor had to extend repair 6" beyond the defect.</i></p> <p>1. F. Soil to Air Interface Zone</p> <p>1. F. (5) Revised, The UV resistant coating should extend from approximately 12 inches below grade to above final grade.</p> <p>Changed from approximately 12 inches above grade.</p> <p><i>Approval committee made this change feeling it was only necessary to get the wrap above the final grade.</i></p> <p>4. Approved Field Applied Epoxy Coatings</p> <p>Expanded the table to include the associated items and stock codes for Denso Protal 7200, 7125 and 7300.</p> <p>5. Approved Cold Applied Wax Tape</p> <p>Deleted the TC Profile Putty</p> <p><i>Tapcoat has put an expiration date on the profile putty. Since the profile putty is not used on a regular basis, this will increase the potential for using a product that has expired or an increase in the amount of material that has to be disposed</i></p>	<p>October 15, 2018</p> <p>April 1, 2019</p>
CORR 2.25	<p>AC Interference on Buried Pipelines</p> <p>3. Investigating AC Voltage on Pipelines</p> <p>3. G. Select a Solution</p>	<p>January 1, 2018</p> <p>April 1, 2019</p>

3. G. (2) (b) Added "A MTF kit is used to attach the SSD to the flange.

Update the photo and added a new stock code.

Removed the Over Voltage Protector since these are no longer being installed.

CORR 2.29	<p>Records</p> <p>2. Construction Order Review Process</p> <p>2. B. Belleville Design Center/Peoria Design Center</p> <p>2. B. (2) (b) A new Cathodic Protection Review stamp replaced an older version.</p> <p>2. C. Cathodic Protection Design Review Checklist</p> <p>A new Cathodic Protection Design Checklist replaces an older version.</p>	October 15, 2018	April 1, 2019
CORR 2.32	<p>Protal 7300 - New Section</p> <p>Protal 7300 is an epoxy coating specially formulated that it can be brush applied to damp or wet surfaces at temperatures of 32°F or above.</p> <p>Procedures follow the same format as CORR 2.09 Protal 7200 and CORR 2.10 Protal 7125.</p> <p>Procedures include:</p> <p>Storage</p> <p>Required Tools</p> <p>Personal Protection</p> <p>Surface Preparation</p> <p>Surface Profile Measurement</p> <p>Pipe Temperature</p> <p>Mixing and Brush Application</p> <p>Inspection/Testing</p> <p>Repairs</p> <p>Curing and Handling Times (approximate)</p> <p>Coverage (approximate)</p> <p><i>This section was developed by the CORR SMR Team and reviewed by Denso Technical Representative.</i></p>	New	April 1, 2019
CORR 3.16	<p>AC Stray Current Test Station</p> <p>Test Station Wiring Configuration test block updated with each connection point labeled.</p>	January 1, 2018	April 1, 2019

Installation instructions update for the Reference Cell with Coupon wiring connections

Material list updated with new Riser Pipe, New Model T-3 Custom Test Station and CerAnode Reference Cell in Coupon Housing.

Corrosion Control is now using a Reference Cell in Coupon Housing which replaces an individual Coupon and a separate Reference Cell.

CORR 4	Forms and Reference Materials Added: Dairyland SSD Installation Instructions-3415 MTF Kit Installation with SSD Denso Protal 7300 Procedures Denso Protal Air Cartridge Gun 1000 Setup Elcometer 122 Testex Replica Tape Elcometer 123 Surface Profile Gauge Operating Instructions Elcometer 224 Digital Surface Profiling Gauge Operating instructions Elcometer 224 Digital Surface Profiling Gauge User Guide	October 15, 2018	April 1, 2019
EMER 0	Table of Contents EMER 4: Added Failed Gas Material Tag Updated Electric Cold Load Restoration Policy	October 15, 2018	April 1, 2019
EMER 2.04	Gas Field Personnel 2. inside Odor Compliant - Hazardous Condition This section has been restructured by moving some the language around and eliminating unnecessary verbiage. There are not significant changes in the procedures.	January 1, 2018	April 1, 2019
EMER 2.08	Investigation of Failures 2. Analysis of Failed or Defective Materials 2. F. Reformatted this section, no changes 2. F. Updated Failed Gas Material tag, Rev 06/18	April 1, 2013	April 1, 2019
EMER 4	Forms and Reference Materials Added Form 05 - Failed Gas Material Tag, Rev 06/18 Updated Electric Cold Load Restoration Policy (December 10, 2018)	January 1, 2018	April 1, 2019

These are the instructions used when there is an electrical outage which could have an effect on the gas system when the electric is restored.

GTS Superintendent updated the Cold Load Restoration policy to provide more details on the expected relationship between the GTS supervisors and DSOS.

<u>INCD 0</u>	Table of Contents Forms and Reference Materials Forms: Updated Form 3 with (April 1, 2019)	October ber 15, 2018	April 1, 2019
<u>INCD 1</u>	Incident Reporting 10. Corporate Claims Notification Corrected Nikki Clay's contact number	October ber 15, 2018	April 1, 2019
<u>INCD 4</u>	Forms and Reference Materials Forms: Updated Form 3 with (April 1, 2019)	October ber 15, 2018	April 1, 2019
<u>LEAK 0</u>	Table of Contacts LEAK 4 Added: Heath Gasurveyor 700 Unser's Manual	October ber 15, 2018	April 1, 2019
LEAK 2.01	Indoor Leak Investigation <ul style="list-style-type: none"> • 6. Leaks of Customer Facilities • 6. A. Indoor gas leak on customer facilities • 6. A. (2): If simple repair cannot be made notify customer of the gas leak and advise customer they are responsible for making the repairs (a) Isolate the gas leak upstream of leak: Shut-off appliance control valve or • Shut-off customer owned valve or • Disconnect and cap outlet of meter set or • Plug and cap outlet of meter or • Shut-off and lock meter valve <p><i>Revised to eliminate continual confusion by gas field personnel on when the meter valve had to be locked. There are available options for isolating a leak on customer facilities most of which do not require shutting off and locking the meter valve.</i></p>	October ber 15, 2018	April 1, 2019

<u>LEAK 4</u>	Forms and Reference Materials Added: Reference 21 - Heath Gasurveyor 700 User's Manual (10/06/2016)	Janu- ary 1, 2018	April 1, 2019
MAIN 0	Table of Contents MAIN 2.02 Title change to Lowering or Realignment of Pipe, with new sections: 2. Engineering Review 6. Inspections Required Prior to Movement 8. Inspection Required After Movement MAIN 2.04 Title change to Temporary Pipeline Support Methods, with a new section 3. Temporary Support Methods	Janu- ary. 1, 2018	April 1, 2019
<u>MAIN 1</u>	Requirements 2. Location 2. E. New, New, relocated or replaced mains shall not be installed under buildings. <i>SMR Team felt, since SERV 1 included language that services shall not be installed under buildings, that same language should apply to mains. Part 192 does not include a restriction or procedures for installing a main under a building. Part 192 does provide procedures for installing service under a building. SMR Team felt it is reasonable to assume the requirements for service would apply to a main.</i>	Feb- ruary 1, 2019	April 1, 2019
MAIN 2.02	Lowering or Realignment of Pipe 1. General 1. C. Added, Designation of responsibility for determining feasibility for safely lowering or realigning in-service pipe based on MAOP, pipe material and location. Gas Division Engineering for steel pipe with MAOP of 60 psig or less and PE pipe with MAOP of 100 psig or less. Gas Tech Engineering for steel pipe with MAOP greater than 60 psig. Gas Storage Engineer for all piping in gas storage field. 2. Engineering Review - Renamed and repositioned 2. A. This section was revised and expanded to include those groups responsible for performing this review and what should be included in the review 2. B. Minor revision to clarify that it is in-service pipe. Added that the field procedures should include pipeline support and movement methods.	Octo- ber 1, 2011	April 1, 2019

The SMR team felt it important to identify the engineering groups who should be responsible for evaluating and determining the feasibility of realigning in-service gas lines. Representatives from Gas Engineering (Kowalske) and GTE (Albrecht, McIntyre) were involved in these discussions. A check with Mike Voegele found that the DDC does not evaluate lowering projects.

3. Steel Pipe Maximum Potential Realignment Distance (Strip Back)

3. B. Added, for pipe not shown in the table, Gas Tech Engineering or Division Gas Engineer should be consulted.

Minimum Strip Back Distances table was revised based on information from API RP 1171 Manual Movement of In-Service Pipelines.

4. PE Pipe Maximum Potential Realignment Span

Adjusted the Ditch Length values.

5. Realignment Concerns

5. A. (4) Examine Types of Welds

Added that prior to realigning in-service pipe, consideration should be given to visual and nondestructive inspection of girth welds and any questionable weld should be repaired.

5. A. (5) Know the Pipe Being Moved

Expanded the material properties that should be taken into consideration; wall thickness and seam

6. Inserted new, Inspections Required Prior to Movement.

A. External corrosion - see CORR 1 6.

B. Mechanical damage- If defects are found, see REPR 1

C. Pipe coating - If defects are found, see CORR 2.15 6.

8. Inspections Required After Movement

A. Pipe coating - If defects are found, see CORR 2.15 6.

An engineer in GTE modified procedures based on information from API RP 1171 Manual Movement of In-Service Pipelines. More procedures and guidance were needed to ensure that lowering or realigning does not adversely affect the integrity of the pipe.

MAIN
2.04

Temporary Pipeline Support Methods

1. General

1. A. Revised the wording to clarify it is temporary support for in-service pipe.

1. B. Designation of responsibility for determining temporary support for in-service pipe based on MAOP. Gas Division Engineering for steel pipe with MAOP of 60 psig or less and PE

January 1,
2016 April
1,
2019

pipe with MAOP of 100 psig or less. Gas Tech Engineering for steel pipe with MAOP greater than 60 psig. Gas Storage Engineer for all piping in gas storage field.

These revisions were made to identify what groups should be responsible for determining temporary support methods in-service gas lines.

2. Support Method Table - New name

Revised the notes under the support method table.

Temporary support should remain in place until backfilled.

In backfilling, use of rock shield should be considered to protect the pipe.

Ensure pipe is flat on the trench bottom and padded well.

Added a note under maximum span table to consult with Gas Tech Engineering or Pipeline Toolbox for pipe diameters not shown in table.

3. Temporary Support Methods - added a title for depicted methods

3. E. New - Sling Method of Pipe Support

3. F. New - Side boom/Backhoe Method of Pipe Support

3. G. Other: There could be other methods but Engineering should approve these methods of temporary support

SMR Team felt there needed to be a little more guidance in these procedures. A GTE engineering confirmed the existing span lengths through the use of the Pipeline Toolbox Software Application.

MAIN
2.06

Insertion

January 1,
2016

April 1,
2019

2. Considerations

2. B. Replaced "should" with "shall" and added "or made inoperable" for existing in-line valves within the casing pipe.

This is an alternative to removing an existing valve. The main objective is make sure that the inserted pipe cannot be cut or damaged due the use of a valve in the casing pipe. This situation occurred when a water department person operated an old gas valve thinking it was a water valve.

METR 0

Table of Contents

October 15,
2018

April 1,
2019

METR 2.23 Gas Meter Exchange

Moved Meter Exchange Using Portable CNG Grunsky Apparatus to new section METR 2.29.

New:

METR 2.29 Gas Meter Bypass

Added:

METR 3.27 250 Class Meter Set with System Bypass Valve

METR 4

Reference 20 - A Y McDonald Portable Bypass Kit Instructions

METR 2.16	<p>Gas Meter Data Sheet</p> <p>1. General</p> <p>1. A. Deleted "that operate at elevated metering pressure"</p> <p>2. Gas Meter Data Sheet</p> <p>Reformatted 2. A. so that each situation requiring a GMDS is listed separately.</p> <p>Reformatted to eliminate confusion as to when a GMDS had to be completed. The common thought was GMDS are required when elevated metering pressure is involved. In most cases this is true, but a GMDS is required for all meter index changes.</p>	October 15, 2018	April 1, 2019
METR 2.23	<p>Gas Meter Exchanges</p> <p>Moved Meter Exchange Using Portable CNG Grunsky Apparatus to new section METR 2.29.</p>	October 15, 2018	April 1, 2019
METR 2.29	<p>Gas Meter Bypass</p> <p>This section contains procedure for two methods that can be used to bypass the gas meter without interrupting the service to the customer.</p> <p>2. Portable CNG Tank System with Angled System Bypass Valve Procedure</p> <p>A new method is being added that utilizes an angled system bypass valve installed on 250 class meter sets in conjunction with a CNG tank.</p> <p><i>Gas Standards group and the Metering group evaluated, approved and recommended that AIC begin installing angled system bypass valve on replaced and new class 250 meter installations. This should improve future customer satisfaction by not having to interrupt their service when work is performed on the service line or on the meter set.</i></p> <p>3. Portable CNG Tank with Grunsky Apparatus Procedure</p> <p>This procedure was brought over from METR 2.23.</p>	New	April 1, 2019
METR 3.27	<p>250 Class Meter Set with System Bypass Valve</p> <p>Provides a sketch of a class 250 meter set with the angled system bypass valve installed on the outlet of the meter bar.</p>	New	April 1, 2019

Material list shows the stock code of the angled bypass valve.

METR 4	Forms and Reference Materials Updated - added Stock Code Number Reference 07 - Meter Guard 2 inch Posts Reference 08 - Meter Guard 4 inch Posts Added: Reference 20 - A Y McDonald Portable Bypass Kit Instructions	October 15, 2018	April 1, 2019
ODOR 0	Table of Contents ODOR 4 Added Heath Odorator 2 Operator's Manual Removed Bacharach Odorometer Manual Heath Odorator 2 User Manual YZ-DTEZ Odorant Detection System	October 15, 2018	April 1, 2019
ODOR1	Requirements 2. Odorization Requirements 2. B. Minor word changes "to" replaced "and", "is" replaced "are", corrected H85 to H-85, and added S-20. 2. C.: Removed the word "diluted" for the H-85 odorant and S-20 replaced TBM 80/20.	October 15, 2018	April 1, 2019
ODOR 2.01	Odorant 2. Odorant Properties and Types 2. B.: Added, odorant blend H-85 is now being used in some AIC odorizers. GTS added H-85 to be used only in controlled circumstances, H-85 is not to be used as an alternate for S-20 blend.	October 1, 2011	April 1, 2019
ODOR 2.02	Odorization Operations 4. Odorization Operations and Inspection 4. B.; 4. B. (1) and (3) and 4. C. Added "Gas Storage Operator" 4. F. (4): Minor word addition S-20 and H-85	October 15, 2018	April 1, 2019

4. F. (6) & (7): Terminology correction, Odorant Injection Rate Investigation replaces warning message.

4. F. (8) Added Gas Storage Supervisor

In addition to GTS personnel, Gas Storage Operators and Supervisors have responsibilities for some odorizers and where appropriate should be follow the same procedures.

ODOR 2.03	<p>Odorant Intensity Testing</p> <p>3. Intensity Test Instruments and Readings</p> <p>3. A. Added "Heath Odorator 2", as the portable air dilution instrument used to determine odor intensity.</p> <p>3. B. Eliminated the list of instruments that could be used to determine odor intensity.</p> <p><i>AIC decided to standardize on the Heath Odorator 2 for performing odor intensity tests.</i></p>	October 15, 2018	April 1, 2019
ODOR 2.04	<p>Emergency Response</p> <p>2. Emergency Response Action</p> <p>2. A. (1) and (2)</p> <p>Added "Gas Storage Supervisor"</p> <p>In addition to GTS Supervisors, Gas Storage Supervisor could be involved in an odorant emergency response since Gas Storage Operator have responsibility for some odorizers.</p>	October 15, 2018	April 1, 2019
ODOR 4	<p>Forms and Reference Materials</p> <p>Updated</p> <p>Heath Odorator 2 Operator's Manual</p> <p>Removed</p> <p>Bacharach Odorometer Manual</p> <p>Heath Odorator User's Manual</p> <p>YZ=DTEX DX1000GL Instruction & Operating Manual</p>	October 15, 2018	April 1, 2019
PMRK 3.03	<p>Regulator Stations</p> <p>1. General</p> <p>1. C. (2) Listed 2 signs that can be used at gas regulator stations that are in a locked fence or an enclosure.</p> <p><i>A new pipeline marker sign has been added which can be used at a regulator station, farm tap or as a pipeline marker, PMRK 3.04.</i></p>	January 1, 2014	April 1, 2019
PMRK 3.04	<p>Pipeline Marker Signs</p> <p>2. Pipeline Marker Signs</p>	January 1, 2012	April 1, 2019

2. C. New Pipeline Marker sign that has "No Smoking" added which allows it to be used at Regulator Stations, Farm Taps or as a pipeline marker.

This new sign replaces the need to have a Regulator Station sign and a pipeline marker sign posted at a regulator station.

POLY 2.04	<p>Butt Fusion</p> <p>5. Joint Assembly</p> <p>5. K. Check heating iron for proper temperature</p> <p>5. K. (1): Added Note: Infrared pyrometers should have an emissivity setting of 0.95.</p> <p><i>McElroy says this is the correct setting for the proper temperature measurement of their heating iron faces. A change in the emissivity setting will significantly the temperature readings.</i></p> <p>5. M. Inserting heating iron between pipe ends</p> <p>5. M. (2): Correction, Once the pipe is closed against the heating faces, reduce the pressure to contact pressure only. Do not wait for the first indication of melt before reducing the pressure.</p> <p>The indication of melt applies to pipe 14 inches and larger per McElroy's instructions.</p> <p>5. N. Correction, deleted the hold pipe ends in contact with heater face until heating cycle is complete.</p> <p><i>The pipe ends are held in contact with the heater faces until the proper melt bead is formed. This is already in the instructions. Eliminating the heating cycle avoids confusion.</i></p>	Janu- ary 1, 2019	April 1, 2019
PRES 0	<p>Table of Contents</p> <p>Removing PRES 2.01 Mechanical Chart Recorders</p> <p>PRES 2.03 added 3. Low Pressure Systems</p>	Janu- ary 1, 2014	April 1, 2019
PRES 2.03	<p>Potential Over Pressurization or Service Interruption</p> <p>2. Pressure Monitoring While Performing Work Activities</p> <p>2. B. (7) New, Replacement work affecting a low pressure distribution gas system</p> <p>2. B. (8) New, Regulator station maintenance work on a low pressure distribution gas system</p> <p>3. Low Pressure Systems (4 inch to 14 inch water column) - New section</p> <p>Added a table listing AIC's low pressure systems:</p> <p>Belleville 5150, Alton ALR 106_LP, Jacksonville 36-64 and Peoria X436.</p>	Sep- tem- ber 1, 2016	April 1, 2019

Pressure monitoring on these system requires a designated individual to constantly observe the downstream pressure during work activities.

5 Activities Requiring an Operational Checklist

5. B. (1) Added, Tapping and stopping operations on low pressure mains.

In reviewing the O&M following the explosions near Boston in 2018, it was evident that additional precautionary steps needed to be added to address working on low pressure gas system. When working on a low pressure system, constant monitoring of the downstream pressure is critical to avoid an over-pressurization.

6. Activities Requiring an Operational Checklist and Written Procedure

6. D. New, A pre-job meeting should be held to review the written procedures

It is extremely important that everyone involve in the uprating a system fully understands the procedures and their area of responsibility. This steps was missing from the procedures.

PRES
2.04

Overpressure Reporting

1. E. Expanded the information that the Gas Supervisor will need to furnish to Gas Compliance when the MEP is exceeded.

1 E. (1): Date and times of occurrence

1. E. (2): Name, job title and phone number of person who determined the condition

1. E. (3): Pressure system ID and regulator station ID and physical address if regulator malfunction occurred

1. E. (4) Actual pressures observed during the MEP Exceedance

1. E. (6) Apparent cause of overpressure condition

1. E. (7) Corrective action taken including reduction in pressure or shutdown to date and the planned follow-up of future corrective action. Including anticipated schedule for starting and concluding such corrective action.

1. F. Added, Gas Compliance shall notify PHMSA within 5 days for the occurrence and concurrently notify the ICC Pipeline Safety Department. Provided the email link for notifying PHMSA.

Gas Compliance requested that additional information be provided when the MEP is exceeded. This will provide them with the necessary information to report to PHMSA and ICC.

October
15,
2018

April
1,
2019

PTST 1	<p>Requirements</p> <p>1. G. Added, "pre-test pipe" for by-pass through the tapping and stopping equipment. The pre-tested pipe would have to be tested at 1.5 times the maximum pressure encounter during the stopping operation.</p> <p><i>Pre-tested pipe was not originally included for by-passing through the machines. However, the use of pre-test pipe has been observed and the testing requirements needed to be specified.</i></p> <p>3. Test Recording Methods</p> <p>3. (2) Pressure Recording Device</p> <p>3. (2) (d) New; Gauges or recorders which have digital display should be read and recorded in whole units. Reading shall be rounded down to the nearest whole psig unit.</p> <p><i>The digital gauge are so sensitive they will register the smallest fluctuation in pressure. This has created problems when there has been a small fizzer leak on a test tree. The O&M states that any leak found must be repaired and the leak test started over. The team felt that recording pressure in whole unit terms would bring consistency between spring gauges and digital gauges.</i></p> <p>8. Component - Title change</p> <p>8. A. (4) New, Gauge tap type components are to be tested prior to tapping.</p> <p><i>Was added to emphasize that these fittings must be test prior to taping. This is consistent with the language in TAPS 1 7. C. which states the fitting shall be pressure tested prior to tapping.</i></p> <p>8. B. Revised to a set minimum duration of 10 minutes when checking a single component for leaks.</p> <p><i>Simplified by removing language about use of gauge or time it takes to check for leaks with detection fluid.</i></p> <p>8. D. Clarification on testing assemblies, Assemblies with nominal diameter of 2 inches and larger are to be tested in accordance with PTST 1 Table E, Fabricated Units.</p> <p>Assemblies with nominal diameter smaller than 2 inch are tested in accordance with PTST 1 Table A, Service.</p> <p><i>This revision was supposed to be in the October 15, 2018 Update but was inadvertently missed.</i></p> <p>A Note has been added which references TAPS 1 8. B. when the test pressure for a bottom-out fittings/assembly exceeds the collapse pressure of the carrier pipe. TAPS 1 8. B. provides fabricating details and testing details for the assembly.</p>	<p>October 15, 2018</p>	<p>April 1, 2019</p>
--------	--	---------------------------------	------------------------------

Gas Tech Engineering and the Sr. Trainer - Welding developed the procedures and methodology for properly testing bottom-out fittings.

PTST 1 Table E. (2)	<p>Fabricated Unit/Assembly or Short Section of Pipe with Design MAOP of ≥ 100 PSIG</p> <p>Leak Test Duration - Min. 1 Hour</p> <p>Removed the language "Check for leaks with soap or leak detection instrument or"</p> <p><i>Language was causing confusion so the decision was made to make the duration consistent with PTST 1 Table D Steel Main with Design MAOP ≥ 100 PSIG.</i></p> <p>Added Note (3) If the test pressure of the bottom out line stopper assembly exceeds the collapse pressure of the pipe, refer to TAPS 1 8. Testing.</p>	<p>October 15, 2018</p>	<p>April 1, 2019</p>
PTST 2.01	<p>Leak Test</p> <p>4. Leak Test Procedures</p> <p>4. B. (a) Added "verifying operation of the recorder" as a reason to install recording device prior to initial pressurization.</p> <p>4. F. Grammatical revision, Initiate the leak test process as indicated in 4. C. replaced restart test.</p> <p>4. G. Added, Fluctuation shall be documented in the Comments sections on the pressure test stamp. Refer to PTST 1 3. A. (2) (d) if recording device has a digital display.</p> <p><i>Provided instructions as to where pressure fluctuation is to be documented and the reference to PTST 1 3. provides instructions that the pressure is recorded on whole units</i></p> <p>5. Leak Test Records</p> <p>5. A. identified what test forms are located in PTST 4.</p> <p>5. E. (3) & (4) Added the word "leak"</p> <p>5. E (9) Added Recording device type and</p> <p>5. E. (11) Clarifies leaks and failures are documented in the Comments section of the test stamp.</p> <p>5. E. (12) Clarified that pressure fluctuations due to outside forces is recorded after the pressure has stabilized.</p>	<p>January 1, 2018</p>	<p>April 1, 2019</p>
PTST 2.02	<p>Strength Test</p> <p>3. Strength Test Procedure</p> <p>3. A. (2) Added, Air, nitrogen or natural gas is being used</p> <p>3. D. (1) Added, Verify operation of the recorder</p> <p>3. F. Added, Reestablish the strength test pressure for the required duration.</p>	<p>September 1, 2016</p>	<p>April 1, 2019</p>

- 3. G. Added, Fluctuation shall be documented in the Comments sections on the pressure test stamp. Refer to PTST 1 3. A. (2) (d) if recording device has a digital display.

Provided instructions as to where pressure fluctuation is to be documented and the reference to PTST 1 3. provides instructions that the pressure is recorded on whole units

4. Strength Test Records

- 4. A. identified what test form is located in PTST 4
- 4. B. (3) & (4) Added, strength
- 4. B. (9) Added, Recording device type
- 4. B. (11) Clarifies leaks and failures are documented in the Comments section of the test stamp.
- 4. B. (12) Clarified that pressure fluctuations due to outside forces is recorded after the pressure has stabilized.

PURG 2.01	<p>Purging Methods</p> <p>1. General</p> <p>1. D.: Removed, "This section does not apply to purging activities conducted at the Ameren Illinois gas storage fields. Gas storage fields have their own purging procedures."</p> <p>Storage fields do not have separate purging procedures. Purging is performed following the procedures in PURG.</p> <p>5. Purging of Gas with Air During Abandonment</p> <p>5. E. Table Under Documentation, added Complete Purge Stamp. Purge Stamp is in ABND 4 Form 01.</p>	October 15, 2018	April 1, 2019
REGS 1	<p>Requirements</p> <p>2. Regulator Station Inspection Schedule</p> <p>2. B. Added the word "approximately" so that stations which serve approximately 250 customers will receive a primary inspection every 10 year.</p>	January 1, 2016	April 1, 2019
REGS 2.01	<p>Regulator Station Inspections</p> <p>7. Gas Leakage</p> <p>7. E. Added, Above grade, Above grade Class 3 leaks repaired at the time of the inspection shall be documented within ClickMobile by initiating a leak investigation.</p>	January 1, 2018	April 1, 2019
REGS 3.01	<p>Regulator Station Design</p> <p>2. General Guidelines and Requirements</p> <p>2. B. Update the reference link</p> <p>2. F. Updated the reference link</p>	January 1, 2018	April 1, 2019

3. Standardized Design Features

3. D. (3) New, Installation of below grade control lines should be minimized whenever possible.

3. D. (4) Additional requirements for below grade control lines; control lines should be separated, Buried Gas Pipeline Caution Tape installed over the control lines and control lines should be documented on as-built prints.

These revision were added to provide additional protection against excavation damage and to ensure location of below grade control lines are recorded. Concerns for below grade control lines are a result of the recent explosions in the Boston area.

3. J. Revised, Inlet and outlet steel risers shall be coated in accordance with CORR 2.03 1. F. - Soil to Air Interface Zone.

Eliminated stating the actual height above the surface that the risers should be coated. That is covered in CORR 2.03 1. F.

3. L. & M. New, these two sections address the protection of above ground regulator stations against accidental damage by vehicular traffic. 3. M. provides factors to be taken when determining if the regulator station is a safe distance from vehicular traffic.

3. N. Expanded the issues that need to be considered for the need of security fencing around an above ground regulator station to prevent unauthorized entry.

The SMR team was requested to develop additional guidelines and procedures for addressing how to protect above ground regulator stations from vehicular damage and unauthorized entry. Steve Blunier with GTE assisted in the development of this revision. This language is necessary to clear a NOA issued by the ICC.

REPR 1

Requirements

2. Leak Repairs

2. H.: New, In a storage field, installing two barriers is considered a permanent repair for a leak on a storage field well. A barrier is considered installing a bridge plug, loading the well with water or other engineered barrier method.

Leak in a gas storage field well was not previously addressed in the O&M. Gas Storage personnel submitted the language that should be in the O&M.

3. High Pressure Distribution and Transmission Pipe Repair

3. C. (6): Deleted "such as turning off rectifier during repair process"

Documentation from Lincoln Welding and NACE indicate that a rectifier does not affect welding nor is it a source of acci-

October
15,
2018

April
1,
2019

dental ignition so this consideration in the planning phase is unnecessary.

3. G. (2): Deleted the reference link to ACIG 2.01 3. Welding and Other Hot Work.

3. G (3): Deleted "See ACIG 2.01 2 Tools and Equipment, if segment is being installed on a rectified system."

4. Steel Distribution Pipe Repair

4. F. (2): Deleted the reference link to ACIG 2.01 3. Welding and Other Hot Work.

4. F. (3): Deleted "See ACIG 2.01 2 Tools and Equipment, if segment is being installed on a rectified system."

The information in 3. G. (2) and 4. F. (2) is the same as in ACIG 2.01 3. so the link didn't provide additional information.

A NACE publication explained that the rectifier DC voltage is typically between 1.0 and 3.0 VDC which is not a safety hazard nor a source of ignition. Arcing across separated pipe is the potential source of ignition which is eliminated by installing a bond cable prior to cutting the pipe.

SERV 3.08	Farm Tap, Double Cut, DOT Transmission Bill of Materials Item 14 - Fisher 627- Corrected Set Point to 20 PSIG Item 30 - Fisher 1805 - Added Set Point 30 PSIG. <i>Original version at the Fisher 627 set at 30 psig. However, SERV 2.03 2. D. for the DOT farm tap, the regulator set point is 20 psig and the relief set point is 30 psig.</i>	October 15, 2018	April 1, 2019
STLP 3.01	Weld Fittings Updated listing of stocked weld fittings including stock codes.	January 1, 2016	April 1, 2019
TAPS 1	Requirements 8. Testing 8. B. New testing and fabricating procedures for bottom-out fittings when the required test pressure exceeds the collapse pressure of the carrier pipe. <i>Gas Tech Engineering and Sr. Trainer - Welding developed these step by step procedures for this specific situation. The procedures were reviewed and accepted by the Pressure Testing SMR Team.</i>	September 1, 2016	April 1, 2019
TAPS 3.01	Mueller Fittings 1. Low Pressure Line Stopper Fitting Corrected Tap Size to 3-3/4" for 19 23 148	January 1, 2018	April 1, 2019

7. Mueller Curb Stop Tee

Added the in-line curb valve tee H-17900

VALV 3.03	Kerotest Gate Valve Removed Stock Code 39 22 148 - 1" 1200 psig valve since it was a Mueller inline curb valve and not a gate valve. This was the first valve listed in the Stock Code Table.	Janu- ary 1, 2018	April 1, 2019
WELD 0	Table of Contents Updated WELD 4	Janu- ary 1, 2018	April 1, 2019
WELD 4	Forms and Reference Materials Updated: Ref 01 - SMAW Matrix - Butt Weld Fixed Position Ref 08 - SMAW-Ameren-006 Rev 3 Ref 09 - SMAW-Ameren-007 Rev 3 Added: Ref 61 - Ameren-008	Janu- ary 1, 2018	April 1, 2019

Supersedes: February 1, 2019

CHANGE SUMMARY

February 1, 2019

Change Summary February 1, 2019

Docu- ment	Change Summary	Previous Docu- ment Dated	Current Docu- ment Dated
---------------	----------------	------------------------------------	-----------------------------------

There are two primary reasons for this O&M Revision.

1. The Butt Fusion, Electrofusion, Mechanical Joining and Plastic Fusion Qualification procedures have been updated to follow the procedures of the pipe manufacturer, fitting manufacturer, electrofusion processor manufacturer and butt fusion machine manufacturer. These procedures were used and distributed during the 2019 PE Fusion Qualifications which began in early January..

2. PHMSA published the Plastic Pipe Rule on November 20, 2018 with an effective date of January 22, 2019. Revision in CORR 1, MAIN 1, POLY 1 and SERV 1 were made to comply with this new rule.

Requirements

4. Cathodic Protection of New and Replaced Pipeline Facilities

4. D. Added the words "buried and submerged"

4. D. (1) Added - "Tests, investigation or experience shows that" adequate corrosion control is provided by the alloy composition.

4. D. (3): New section which addresses isolated metal alloy fitting installed after January 22, 2019 in buried or submerged plastic pipe systems.

CORR
1

These revisions were necessary to bring the O&M into compliance with 192.455 requirements of the new Plastic Pipe Rule effective January 22, 2019.

Janu-
ary 1,
2018

Febru-
ary 1,
2019

13. Atmospheric Corrosion

13. A. Added - Facilities with light surface oxidation can be marked as "Needs Paint" within ClickMobile.

Light surface oxidation, rust, is not considered atmospheric corrosion and should not be reported as such. During an ICC field audit there was a question on how does a facility that needs painting get reported.

13. C. Added the word "new" to above grade facilities that must be coated within 1 year.

Requirements

MAIN
1

8. Underground Clearances

8. A. New, Underground clearances apply to plastic and steel pipe installed either by direct bury or trenchless methods.

Janu-
ary 1,
2018

Febru-
ary 1,
2019

8. B. Revised, At time of installation, there shall be sufficient clearance to allow for installation and maintenance activities.

8. B. (1) Combined clearance requirements for transmission lines, high pressure distribution and distribution mains since they were essentially the same, 12 inches for other existing buried structures or utilities.

Added a Note that abandoned facilities should be considered since they have a potential to provide a path for migration of leaking gas.

Note came from a GPTC guide material for Part 192.325 Underground Clearance

8. B. (2) Reformatted measures that shall be taken to protect the pipe if the minimum clearance cannot be obtained

8, B. (4) Added a reference to POLY 1 4. Clearance from Thermal Sources, for PE pipe installed near a steam pipe.

In the new Plastic Pipe Rule, 192.329, plastic pipe installed by trenchless excavation the operator is take practical steps to provide sufficient clearance for installation and maintenance activities from other existing underground facilities. In BORE 2.02, which applies to both steel and plastic pipe, it references MAIN 1 8 for clearance requirements for mains.

9. Joining

9. B. Combined a couple of sentence, Butt fusion and electrofusion should be used to join PE pipe.

9. C. Removed, Heat fusion is the principal method of joining PE Pipe.

Table of Contents

POLY 1 Requirements - Added 1 new section

POLY 2.04 Butt Fusion - Inserted 3 new sections

POLY 2.06 Electrofusion - Inserted or renamed 7 sections

POLY
0

POLY 2.07 Mechanical Joining - Added Permasert 2.0

POLY 2.09 Plastic Fusion Qualifications - Inserted 1 new section

October
15,
2018

January 1,
2019

POLY 3.05 Stab Fittings - Added 1 new section

POLY 4 - Forms and Reference Materials - Updated 12 Reference Manuals

Requirements

POLY
1

1. B. New, PE pipe shall be inspected for external damage before it is installed.

2. Handling

October
15,
2018

February 1,
2019

2. B. (3) Added "for the McElroy Line Tamer instructions.

2. E. Word changes, "if print line is not legible at time of installation the pipe shall not be installed" replaced "manufactured date cannot be determined the pipe shall not be installed".

Plastic Pipe Rule, 192.63, requires the physical markings to be legible at time of installation. The required marking on the pipe is commonly referred to as "print line".

7. Minimum Bending Radius

7. A. (2) New - Bend shall not be less than the minimum bending radius shown in the table below.

Plastic Pipe Rule, 192.313, specifies that PE pipe may not be installed with a bend radius less than that specified by the manufacturer.

7. A. (3) Word addition, "Bend shall be" free of buckles, cracks, etc.

8. Weak Link

8. A. Added "by excessive forces"

8. B. Deleted words "if the pulling load gets too high"

Plastic Pipe Rule, 192.329, uses the term "excessive forces".

By adding excessive forces in 8. A. the words in B. were not needed.

13. Metal Alloy Fittings - New section

Plastic Pipe Rule, 192.455, amended the requirements on isolated metal alloy fittings installed in a plastic pipe system. This section was added as a reminder to refer to CORR 1 4. D. which includes those requirements.

Butt Fusion

This section has been slightly revised to follow Performance Pipe's latest Heat Fusion Joining Procedures and Guidelines. There are no major procedural changes from our current butt fusion procedures. A couple of definitions were revised or added to better clarify what constitutes Cooling Time and Work Time. Some additional points were added based on Performance Pipe's procedures.

POLY
2.04

The format of this section was changed to simple stated one line bullet points. Cooling and Work Time were updated in accordance with Performance Pipe's procedures. A new section on Bead Inspection was added with updated drawings of acceptable and unacceptable fusion beads.

January 1,
2018

January 1,
2019

The procedures were reviewed and revised by the POLY SMR Team, Sr. Training Supervisor, and representatives from Operator Qualification, Quality Assurance and Gas Standards & Materials. The goal was to follow Performance Pipe's procedures which would ensure our butt fusion procedures would produce an acceptable fusion joint.

Electrofusion

This section has been reformatted and revised to reflect information from the latest Central Plastic's EF Installation Procedure Manual.

The major procedural changes in the EF process are:

1. Central Plastic now states an inverter should be 3500 watts or larger.
2. Out of Roundness requirements have been added primarily for pipe larger than 2 inch.
3. In pipe preparation, an area 3 times the length of the coupling, elbow, cap and the width of the tee saddle is to be cleaned with an alcohol solution and remain clean throughout the fusion process.
4. The area to be scraped is to be marked in a criss-cross pattern. The scraping operation must remove all of the marking to ensure the pipe has been properly scraped.
5. During the scraping process, the ribbon material should be kept off the scraped area by either breaking off the ribbon material while scraping or guiding the ribbon material away from the scraped area to avoid possible re-contamination.

January 1, 2018 January 1, 2019

POLY
2.05

Requirements that were applicable to and repeated in each of the EF processes have been combined into a new section, 3. Common Requirements. This section contains additional Information on EF fittings packaging and storing, when re-fusing is allowed and inspection of the joint after completion of the fusion cycle.

The EF procedures were reformatted into chart form. The charts were divided into sections; Pipe Preparation, Scraping and Joint Assembly.

The procedures were reviewed and revised by the POLY SMR Team, Sr. Training Supervisor, and representatives from Operator Qualification, Quality Assurance, Gas Standards & Materials and George Fischer Central Plastics. The goal was to follow Central Plastic's EF procedures which would ensure our EF procedures would produce an acceptable fusion joint.

Mechanical Joining

Major change in this section is mechanical fittings installed after January 22, 2019 shall be a Category 1 fitting.

January 1, 2018 January 1, 2019

POLY
2.06

This is a PHMSA requirement published in the Plastic Pipe Rule, 192.281 (e) (4), on November 20, 2018. AIC stocks only Category 1 compression and stab fittings.

The Continental CON-STAB section was removed since these are no longer used by AIC.

The Permasert/Permasert 2.0 procedures were formatted in chart form.

Plastic Fusion Qualification

POLY 2.09	Added the procedures for Crush Testing EF Joints made during EF qualifications. A successful Crush Test will meet the requirements of ASTM F1055 for a qualified EF joint.	Janu- ary 1, 2018	Janu- ary 1, 2019
--------------	---	-------------------------	-------------------------

Storage and Handling PE Material - NEW Section

Topics addressed in this section are:

Receipt Inspection: verification of accuracy of material, manufacture date and no damage

Handling: pipe coils and silos, unloading in relatively level area, extra care when temperatures are below freezing and damaged pipe should not be used

POLY 2.10	Unloading: procedures for unloading stick pipe, coiled pipe from truck, safety precautions, methods of protecting pipe from damage	New	Febru- ary 1, 2019
--------------	---	-----	--------------------------

Storage: shelf life of PE pipe (3years for MDPE, 10 years for HDPE), stack height for silos, prohibited storage locations, un-bundled stick pipe stacked per pipe manufacturer's instructions

PHMSA's Plastic Pipe Rule, 192.67, requires operators to have written procedures for storage and handling plastic pipe and components. Gas Standards and Materials personnel worked with Stores in developing these procedures.

Stab Fittings

POLY 3.05	Added Permasert 2.0 to all of the stab fittings and updated the information in the tables. Added Repair Couplings - Permasert 2.0 for 1/2" CTS and 1" CTS.	May 1, 2010	Janu- ary 1, 2019
--------------	---	-------------------	-------------------------

Forms and Reference Materials

Revised file name for:

Reference 02 - FRIAMAT Fusion Units Operating Instructions

Updated:

POLY 4	Reference Manuals on all of the McElroy Butt Fusion machines, Test Cap. Line Tamer. Reference Manuals for the 28EP and 28HP Connectra butt fusion machines	Janu- ary 1, 2016	Janu- ary 1, 2019
-----------	---	-------------------------	-------------------------

Performance Pipe Fusion Procedures

GF MSA 340 Operating Manual

Central Plastic EF Installation Booklet

Requirements

4. Underground Clearances

4. A. New, Underground clearances apply to plastic and steel service lines installed either by direct bury or trenchless methods.

4. B. Revised. At time of installation, there should be sufficient clearance to allow for installation and maintenance activities:

4. B. (1) A minimum of 12 inches vertically and horizontally, between service line and buried electric

Added Note: Electric lines can produce heat.

4. B. (2) A minimum of 6 inches vertically and horizontally between service lines existing underground structures or utilities.

Added a Note that abandoned facilities should be considered since they have a potential to provide a path for migration of leaking gas.

4. B. (3) Refer to POLY 1 4. Clearance from Thermal Sources, if PE service line is being installed near a steam pipe.

In the new Plastic Pipe Rule, 192.376, plastic service lines installed by trenchless excavation the operator is take practical steps to provide sufficient clearance for installation and maintenance activities from other existing underground facilities. In BORE 2.02, which applies to both steel and plastic pipe, it references SERV 1 4. for clearance requirements for service lines.

4. B. (3) Separated from and reworded original 4.A. - Refer to POLY 1 4. Clearance from Thermal Sources, if PE service line is being installed near a steam pipe.

5. Location

5. E. (1) (a) Added "crawl space opening"

Makes this bullet point consistent with the Exhibit 3.

Gas Service Card

3. Service Sketches

3. B. Service Sketch Card replaces former Gas Service Transaction Card.

3. B. (4) Added DOJM Number to information requested on Service Sketch Card.

4. Completion Instructions

4. B. Service Sketch Card replaces former Gas Service Transaction Card. Service Sketch Card Stock Code numbers were added.

January 1, 2018

February 1, 2019

December 1, 2014

February 1, 2019

SERV 1

SERV 2.06

Supersedes: October 15, 2018

UNCONTROLLED IF PRINTED

CHANGE SUMMARY

October 15, 2018

Change Summary October 15, 2018

Document	Change Summary	Previous Document Dated	Current Document Dated
Table of Contents	<p>Removed the following sections since they have been eliminated over the past years.</p> <p>ABND 2.02 - Joint Abandonment of Mains and Services (now contained in ABND 2.01)</p> <p>ABND 2.03 - Abandonment of Transmission Facilities (now contained in ABND 2.01)</p> <p>ABND 2.04 - Contaminants (now contained in ABND 2.01)</p> <p>ABND 2.07 - Discontinued Service (now contained in TURN 2.03)</p> <p>LEAK 2.14 - Leak Surveys - Special Distribution Leak Survey (this survey ended January 1, 2016)</p> <p>METR 2.21 - Pipeline Meter and Chromatograph Calibrations (no longer applicable)</p> <p>POLY 2.03 - Heat Fusion (now contained in POLY 2.04)</p> <p>REGS 2.02 - Primary Inspection - (now contained in REGS 2.01)</p> <p>REGS 2.05 - Gas Compliance System Inspection Forms - (replaced by Maximo electronic forms)</p> <p>SECR 2.01 - Communicating Security Threats (now in Corporate Gas Security Plan)</p> <p>SECR 2.02 - Critical Gas Facility Risk Control Measures (now handled by Corporate Security)</p> <p>WELD 3.01 - Post-Weld Heat Treatment (not applicable to AIU)</p>	January 1, 2018	October 15, 2018
ABND 0	<p>Table of Contents</p> <p>Removed ABND 2.02, 2.03, 2.04 and 2.07 since they were removed in the January 1, 2018 Update.</p> <p>ABND 2.01: Changed the following:</p> <p>2. Transmission Lines and Distribution Mains</p> <p>4. Joint Abandonment of Transmission Lines and Distribution Mains and Services</p>	January 1, 2018	October 15, 2018
ABND 2.01	<p>Abandonment of Gas Facilities</p> <p>Throughout the document "transmission lines and distribution mains" replaced the word "mains"</p> <p>1. General</p>	January 1, 2018	October 15, 2018

UNCONTROLLED IF PRINTED

1. D.: New: Purging of abandoned facilities shall be performed and documented in accordance with PURG 2.01 5. Purging of Gas with Air During Abandonment.

Documentation that purging of abandon gas facilities was completed is now required to address an NOPV issued by the ICC.

4. Joint Abandonment of Transmission Lines of Distribution Mains and Services

4. B. Engineering should prepare specific procedures:

4. B. (7): Revised: A sequence and procedures for abandonment and purging operations in accordance with PURG 2.01 3. Purging Transmission Lines, High Pressure Distribution Mains and PURG 2.01 5. Purging of Gas with Air During Abandonment.

In PURG 2.01 contains information on which facilities require a Purge Plan and what documentation is required.

Throughout Section 3 Services, the hyperlinks were updated to go to a specific section within the referenced document.

BORE
2.02

Boring Operations

3. Prior to Beginning Operations

3. C.: Revised: Under hard surfaces such as state highways, driveways, etc, where it may be hazardous or infeasible to expose facilities prior to boring, water line valve boxes and gravity sewer manholes can be checked to verify the depth of those lines. If the depth of an underground facility cannot be verified to be clear of the proposed bore path, the Ameren Damage Prevention team should be contacted in order to determine a course of action which best limits risk and is in compliance with JULIE requirements. The facility must be uncovered, at a minimum, on each side of the hard surface before boring begins.

Safety and Damage Prevention revised the language to bring procedures in line with the JULIE Law. The new language is the same as in AIU's Safety Manual.

January 1,
2018

October 15,
2018

BORE
2.03

Pipe Installation

2. PE Pipe

2. G.: New, added POLY 1 8. C. contains the maximum allowable tensile loads for PE pipe and lists the corresponding weak links for each size of PE pipe.

Move the Max Allowable Tensile Load information to POLY 1 and incorporated it with the weak link table.

January 1,
2016

October 15,
2018

Throughout the document the hyperlinks were titles were added and the links updated to go to a specific section within the referenced document.

BORE
2.04

Boring Across or Near Sewer Lines

January 1, 2018
October 15, 2018

1. General

1. A.: Added, "to avoid installing gas line through a sewer line or sewer lateral."

1. B.: Added, "or sewer laterals that are within the proposed bore path."

4. Construction Steps

4. A.: Revised to, Before boring, conduct a final inspection along the proposed bore path looking for possible unmarked sewer facilities and ensuring the depth to the marked sewer lines have been verified not to be in conflict with proposed bore path.

Best practice from articles on cross boring recommend a final walk through before beginning boring looking for the possibility of unmarked facilities.

4. B.: Was former 4. C. and was revised to, Every effort should be made to maintain the clearances shown in MAIN 1 8. A. or SERV 1 4. B. between the gas line and the sewer line.

4. F.: Grammatical correction, verified to be clear of the bore path replaces verified not to be in close proximity of the bore path.

CONS
2.01

Construction Inspector Responsibilities

January 1, 2018
October 15, 2018

2. Job Assignment

2. E.: Grammatical revision, Contractor replaced inspector.

CORR 0

Table of Contents

January 1, 2018
October 15, 2018

CORR 4 Forms and Reference Materials

Added Reference 24 through 32.

CORR
2.03

Coatings

January 1, 2018
October 15, 2018

1. Approved Coatings

1. F. (3): Added moisture cured wrap that can be used to wrap riser at soil to air interface zone.

1. F (4): Removed the examples of approved underground coatings.

7. Approved Paint Specifications

7. A. (3): Word change, "paint" replaced "epoxy" since the approved Tnemec 2 part paint is not epoxy.

7. C.: Revised because the application temperature limitations are in the paint specification sheets and not on the containers. Points out that temperature is of the pipe not the ambient temperature.

CORR 2.09	<p>Protal 7200</p> <p>1. C.: Corrected shelf life to 2 years from manufactured date. Added, The Protal tubs and pails have a use by date which would be the last day of the month shown.</p> <p>Shelf life information in current O&M was copied from manufacturer's Protal 7200 specification sheet. A check with manufacturer found this information was incorrect and their specification sheet needed to be corrected.</p> <p>2. A. (9): Added stock code for 1 gallon jugs of MEK liquid.</p>	January 1, 2018	October 15, 2018
CORR 2.23	<p>Clearing Shorted Pipelines</p> <p>3. Preformed FRP Spacers - Type 120 - Stocked</p> <p>3. B.: Replaced the specific product names with "an approved field applied liquid/epoxy coating, CORR 2.03 5."</p>	January 1, 2016	October 15, 2018
CORR 2.29	<p>Records</p> <p>2. Construction Order Review Processes</p> <p>2. B. (1) (c): Dave Wiegand replaced Michael Lemkuhl name from table.</p>	January 1, 2018	October 15, 2018
CORR 3.02	<p>Anode Test Station</p> <p>Corrected the detector wire that is attached to the main. Added the stock codes for the 500 ft and 1500 ft spool of #12 tracer wire. Added notes on which size of anode should be installed on steel service lines and mains.</p> <p>The previous listed wire is not suitable for buried installation.</p>	January 1, 2016	October 15, 2018
CORR 3.14	<p>Test Lead Wire Attachment</p> <p>1. B.: Correction, 100 psig replaced 60 psig. This was missed in the January 1, 2018 Update.</p> <p>7. Test Lead Attachment Coating</p> <p>7. B.: Added stock code, 30 10 165, for Viscotaq Coating Patch and that Viscotaq patch is UV resistant.</p> <p>7. C.: Handy Cap is being replaced with Viscotaq Coating Patch but the Handy Cap can continue to be used until supply is depleted. Handy Cap is not UV resistant and should not be used where exposed to sunlight.</p>	January 1, 2018	October 15, 2018
CORR 4	<p>Forms and Reference Materials</p> <p>Added the following reference materials:</p>	Sep- tem-	Octo- ber

UNCONTROLLED IF PRINTED

	24. Sherwin Williams industrial Yellow Paint Data Sheet	ber 1,	15,
	25. Sherwin Williams Meter Set Grey Data Sheet	2016	2018
	26. Sherwin Williams Hunter Green Data Sheet		
	27. Sherwin Williams Ameren Medium Green Data Sheet		
	28. Tnemec Endura-Shield Series 73 Product Data Sheet		
	29. Tnemec Series 530 Omnithane Primer Data Sheet		
	30. Restoleum Hunter Green Aerosol Data Sheet		
	31. CerAnode REF-CELL in Coupon Housing		
	32. Viscotag Coating Patch		
EMER 0	Table of Contents	Janu-	Octo-
	EMER 4 - Updated Ameren Shipping Papers for CNG	ary 1,	ber
		2018	15,
			2018
EMER 2.02	Dispatch Center	Janu-	Octo-
	2. Actions Required By the Supervisory Personnel	ary 1,	ber
	2. A.: Supervisory personnel instructions to dispatcher	2018	15,
	2. A. (1): Revised to, Continue calling qualified gas field personnel following the ARCO's protocol. During emergency situations, AIC has automated call out protocols for contacting qualified personnel from outside the affected area when there is no response from the affected area.		2018
	2. A. (3): Added meter changers and gas supervisors as examples of qualified emergency responders.		
	2. A. (1): Removed, Call qualified gas personnel from another operating center. DSOS does not call responders from outside the operating center. That is the responsibility of Duty Supervisor.		
	3. Cold Weather Electrical Outage and Restoring Electrical Service		
	3. B.: Added, GTS should be notified of scheduled maintenance outages in addition to outages involving the EOC activation.		
	If scheduled electrical maintenance outage is going to involve a large number of customers, GTS wants to be notified so they determine if electric restoration of power will have an effect on the gas system.		
EMER 2.03	Emergency Responder	Janu-	Octo-
	1. Upon Arrival (Inside Leak)	ary 1,	ber
		2018	15,
			2018

2. C.: Before touching meter, added a reference to CORR 2.17 2. A. which has instructions if voltage is detected on meter.

EMER 2.04	<p>Gas Field Personnel</p> <p>11. High Pressure Situations</p> <p>11. A.: Maximum Emergency Pressure replaced MAOP.</p> <p>11. K.: Added a reference to PRES 2.04 Overpressure Reporting when the Maximum Emergency Pressure is exceeded.</p> <p>There are additional reporting requirements when the MEP of a system is exceeded which makes it extremely important for field personnel to verbally contact their Supervisor immediately as required in PRES 4.</p> <p>12. Loss and Restoration of Service</p> <p>12. F. (7): Added a Note: If the EOC is activated for major outage, they will assume control and coordinate obtaining the necessary resources from outside the affected Division.</p> <p>Updated some of the links within the document.</p>	January 1, 2018	October 15, 2018
EMER 4	<p>Forms and Reference Materials</p> <p>Forms:</p> <p>Updated the Ameren Shipping Papers for CNG Revision 04152018</p>	January 1, 2018	October 15, 2018
EXCV 0	<p>Table of Contents</p> <p>Removed EXCV 2.02 - Excavation Flowchart</p>	January 1, 2018	October 15, 2018
FORW	<p>Forward</p> <p>2. Availability</p> <p>2. B.: Updated how AIC files the O&M with the ICC via an Ameren Illinois hosted technology platform as required by IAC Section 590.30</p> <p>5. Contacts</p> <p>Added Tyler Beeler and Mark Popov</p>	January 1, 2018	October 15, 2018
<u>GLOS</u>	<p>Glossary</p> <p>Acronyms used in the Industry and O&M have been listed together.</p> <p>Copied the following definitions from Part 192.3:</p> <p>Control Room</p> <p>Controller</p>	January 1, 2018	October 15, 2018

Customer Meter
Electrical Survey
Exposed Underwater Pipeline
Gas
Gathering Line
Line Section
Low Pressure Distribution System
Pipe
SCADA
Transportation of Gas
Underground Natural Gas Storage Facility
Welder
Welding Operator
Revised the following definitions:
Air Intake
Bar Hole Testing
Boring
Calibrating Gauge
Capable of Being Locked Out
Coating
Company
Conduit
Cubic Feet per Hour (CFH)
Delivery Station
Distribution Main
Emergency
Farm Tap
Gauge
High Consequence Area
In-Service Welding
Maximum Emergency Pressure (MEP)
NDT
Odorization
Odorizer
Protective System

UNCONTROLLED IF PRINTED

Specified Minimum Yield.

Tie-In Test

Transmission Line

Yardline

<u>INCD 0</u>	Table of Contents	April 1, 2017	Octo- ber 15, 2018
	INCD 1:		
	10: Deleted (CCMI) - CCMI has been replaced		
	INCD 4:		
	Updated Form 3 - Potential Incident Report Form (April 1, 2018)		
<u>INCD 1</u>	Requirements	Janu- ary 1, 2018	Octo- ber 15, 2018
	2. Natural Gas Incident		
	2. A. (5): New; An event that results in an emergency shut-down of an underground natural gas storage facility. This does not include activation of the emergency shutdown for non-emergency situations.		
	7. Gas Compliance Contact List		
	Added Mark Popov and contact information		
	8. Reporting Matrix		
	Insert the emergency shutdown of underground storage facility in both tables		
	PHMSA Part 191.5, included this item in the definition of an Incident.		
	9. State & Federal Contact Numbers:		
	Updated ICC's contact numbers		
	10.: Corporate Claims Notification:		
	Updated contact information for Brentwood Services who replaced CCMI.		
	11. Ameren Illinois Communications Notification:		
	Expanded contacts during working hours. There are now contact individuals for; Divisions 1 & 2; Divisions 3 & 4 and Divisions 5 & 6.		
	13. Post-Incident Alcohol and Drug Testing:		
	Updated Karan Henderson's after hours contact number.		
<u>INCD 4</u>	Forms and Reference Material	April 1, 2017	Octo- ber 15, 2018
	Updated Form 3 - Potential Incident Report Form (April 1, 2018)		

<u>LEAK 0</u>	<p>Table of Contents</p> <p>Removed LEAK 2.14 - Leak Survey - Special Distribution Leak Survey</p>	<p>January 1, 2018</p>	<p>October 15, 2018</p>
<p>LEAK 2.01</p>	<p>Indoor Leak Investigation</p> <p>4. Customer is Home</p> <p>4. C.: Expanded reference link EMER 2.04 2. Inside Odor Compliant - Hazardous Condition</p> <p>4. G.: Correction, When there is inaccessible piping, a 5 minute shut in test should be performed. The January 1, 2018 Update incorrectly said shall be performed.</p> <p>5. Customer Not Home</p> <p>5. A. Expanded reference link EMER 2.04 2. Inside Odor Compliant - Hazardous Condition</p>	<p>January 1, 2018</p>	<p>October 15, 2018</p>
<p>LEAK 2.02</p>	<p>Outdoor Leak Investigation</p> <p>5. Below Grade Gas Facilities</p> <p>5. C. (1): Bar hole spacing should be adjusted so that the extent of migration can be identified in a minimum of four directions.</p> <p>SMR Team simply added in a minimum of four directions so that there is no question on where the bar hole sampling is to be performed.</p> <p>5. C. (2): Revised, Bar hole locations and % Gas readings used to determine leak classification and location of the leak should be recorded on the leak sketch within ClickMobile. Additional documentation which supports the sketch can be recorded in the comments section of ClickMobile.</p> <p>7. Hazardous Condition</p> <p>7. A.: Expanding reference link to EMER 2.04 3. Outside Odor Compliant - Hazardous Condition</p>	<p>January 1, 2018</p>	<p>October 15, 2018</p>
<p>LEAK 2.04</p>	<p>Leak Classification and Surveillance</p> <p>4. Leak Classification Criteria</p> <p>4. C.: Removed venting vault, tunnel, sewer and manhole before taking reading.</p> <p>In the SMR Team's opinion an initial reading is going to be taken before there is any venting and that an investigation would be conducted to locate the source of the leak. In addition, in other sections of the O&M, there are procedures for checking for leaks in valve boxes and vaults.</p>	<p>January 1, 2018</p>	<p>October 15, 2018</p>

LEAK 2.14	Leak Survey - Special Distribution Leak Survey Section was removed since this leak survey is no longer required.	January 1, 2016	October 15, 2018
LOCT 0	Table of Contents LOCT 4: Forms and Reference Materials: Added Reference 35 - Pipehorn 800-HL User Manual Reference 36 - ViVax vLocPro 2 vLocML2 User Handbook	September 1, 2016	October 15, 2018
LOCT 2.02	Equipment 2. Electronic Locators Added: Pipehorn 800-HL and ViVax VLocPro 2	January 1, 2016	October 15, 2018
LOCT 4	Forms and Reference Materials Added: Reference 35 - Pipehorn 800-HL User Manual Reference 36 - ViVax vLocPro 2 vLocML2 User Handbook	September 1, 2016	October 15, 2018
METR 0	Table of Contents Removed METR 2.21 METR 2.12: Added 8. AMR/AMI Reading Verification METR 2.14: Added 8. AMR/AMI Reading Verification METR 2.19: Added 8. AMR/AMI Reading Verification METR 2.27: Added 7. AMR/AMI Reading Verification METR 4 Forms and Reference Materials Updated: Form 01- Electronic Corrector Inspection Form July, 2018 Form 03 - Gas Meter Data Sheet (Rev 08-12-2018) Form 05 - Electronic Corrector Verification Form July, 2018 AMR/AMI Reading Verification A. Verify AMR/AMI reads are in alignment with field meter readings. B. AMR/AMI readings lag field readings by 24-48 hours. The 7 day history function on the AMRC screen in OAS can be used to help determine alignment Was added to the following Sections: METR 2.12 Rotary Meter Differential Testing METR 2.14 Electronic Corrector Inspection	January 1, 2018	October 15, 2018
General Note: This same section was added to several of the METR documents.			

METR 2.19 Pressure Factor Verification

METR 2.27 Electronic Corrector Installation Verification

Metering SMR Team and GTS Supervisors felt that it is important to compare AMR/AMI readings with those obtained during inspections, testing and verification checks to ensure metering readings are accurate.

METR 2.12	<p>Rotary Meter Differential Testing</p> <p>8. AMR/AMI Reading Verification</p> <p>A. Verify AMR/AMI reads are in alignment with field meter readings.</p> <p>B. AMR/AMI readings lag field readings by 24-48 hours. The 7 day history function on the AMRC screen in OAS can be used to help determine alignment.</p>	January 1, 2017	October 15, 2018
METR 2.14	<p>Electronic Corrector Inspection</p> <p>8. AMR/AMI Reading Verification</p> <p>A. Verify AMR/AMI reads are in alignment with field meter readings.</p> <p>B. AMR/AMI readings lag field readings by 24-48 hours. The 7 day history function on the AMRC screen in OAS can be used to help determine alignment.</p>	January 1, 2018	October 15, 2018
METR 2.16	<p>Gas Meter Data Sheet</p> <p>The GMDS form has been updated with the following additions:</p> <p>3. Distribution:</p> <p>3. A.: Added "After supervisor approval" and put an email link to the Metering Supervisor.</p> <p>3. B.: Added an email link to IL CAD. Added that IL CAD is receive a copy of GMDS when an meter has a corrector installed.</p> <p>3. C: New, On 11M and larger meter installs, exchanges and removals, a copy of the GMDS should be sent to @IL GT-Clerical and @IL Cust Service Key Account.</p> <p>4. Completion Instructions</p> <p>4. C. (1) Installation Information (Page 1 of 2)</p> <p>4. C. (1) (b) Installation Instructions</p> <p>New (18), Meter temperature compensation: TC or Non-TC.</p> <p>4. C. (1) (d) Auxiliary Equipment</p> <p>New (38): LAN ID: Enter 8 characters with leading zeroes as necessary.</p>	January 1, 2017	October 15, 2018

Revised (39): Site ID #1: Enter the #1 site ID from the auxiliary equipment, (Item 200 programmed with corrector serial number) Note: completely fill each field with 8 digits using leading zeros.

Revised (40): Site ID #2: Enter the #2 site ID from the auxiliary equipment, (Item 201 programmed with the meter number) Note: completely fill each field with 8 digits using leading zeros.

4. C. (1) (e): Meter Set Regulator/Relief Information

New (64): Supervisor Review Initials: Enter the initials of the supervisor completing the review of the completed form.

New (65) Enter the date the form was reviewed

4. C. (2) Removal Information (Page 2 of 2)

4. C. (2) (f): Distribution List

New (94): Supervisor Review Initials: Enter the initials of the supervisor completing the review of the completed form.

New (95): Date: Enter the date the form was reviewed.

METR 2.17	<p>Gas Meter Data verification</p> <p>2. Gas Meter Data Sheet</p> <p>2. B.: Gas field personnel are to forward the completed Gas Meter Data Sheet to their supervisor for approval. The supervisor will ensure the GMDS is forwarded to the appropriate distribution listed in METR 2.16</p> <p>3. Gas Meter Data Sheet.</p> <p>Metering SMR Team cleaned up the language to make it clearer on how the GMDS is to be routed electronically.</p>	January 1, 2017	October 15, 2018
METR 2.19	<p>Pressure Factor Verification</p> <p>New section added:</p> <p>8. AMR/AMI Reading Verification</p> <ol style="list-style-type: none"> 1. Verify AMR/AMI reads are in alignment with field meter readings. 2. AMR/AMI readings lag field readings by 24-48 hours. The 7 day history function on the AMRC screen in OAS can be used to help determine alignment. 	January 1, 2018	October 15, 2018
METR 2.20	<p>Meter Header Inspection</p> <p>2. A. (1) Added instructions if voltage is detected on a gas meter with a reference link to CORR 2.17</p> <p>2. A. AC Voltage at Customer Meter Set.</p> <p>2. A. (9): Grammatical, added the word repair so that it is consistent with 3. A. (8)</p>	January 1, 2017	October 15, 2018

3. A.: Word changes to match 2. A.

3. A. (1): Added instructions if voltage is detected on a gas meter with a reference link to CORR 2.17 2. A. AC Voltage at Customer Meter Set.

3. A. (8): Grammatical, added the word regulator to make is consistent with 2. A. (9)

Makes this section consistent with other sections where the meter set is to be checked for AC voltage.

METR 2.23	Gas Meter Exchange 10. B.: Added instructions if voltage is detected on a gas meter with a reference link to CORR 2.17 2. A. AC Voltage at Customer Meter Set Makes this section consistent with other sections where the meter set is to be checked for AC voltage.	January 1, 2017	October 15, 2018
METR 2.27	Electronic Corrector Installation Verification 7. AMR/AMI Reading Verification A. Verify AMR/AMI reads are in alignment with field meter readings. B. AMR/AMI readings lag field readings by 24-48 hours. The 7 day history function on the AMRC screen in OAS can be used to help determine alignment	January 1, 2018	October 15, 2018
METR 3.04	Regulator Sizing - 2 PSIG Delivery Pressure Typo correction, missed 1" in the description of 62 06 486 American 1813C.	January 1, 2018	January 1, 2018
METR 4	Forms and Reference Materials Updated: Form 01- Electronic Corrector Inspection Form July, 2018 Form 03 - Gas Meter Data Sheet (Rev 08-12-2018) Form 05 - Electronic Corrector Verification Form July, 2018	January 1, 2018	October 15, 2018
ODOR 0	Table of Contents ODOR 1 3. Odorization Intensity Sampling, added Intensity ODOR 2.04 Emergency Response replaces Deodorizing Agents ODOR 4 Update: Form 02 - Ameren Shipping Paper - Odorant Added: Form 03 - Odorant Event Report 8-28-2018	January 1, 2016	October 15, 2018

Reference 11 - ODOR Handy plus Manual Version August 2011

Reference 12 - Becker ACD-300 Charcoal Deodorizer

ODOR 1	<p>Requirements</p> <p>Throughout this section the word "standard" has been added to cubic feet, "standard cubic feet" and to "MMSCF".</p> <p>2. Odorization Requirement</p> <p>2. B.: Revised to address the target odorant concentration level for 80/20 and H85 odorant blends.</p> <p>2. B. (1): For the TBM 80/20 odorant blends the target level range is 0.50 to 1.25 Lbs/MMSCF.</p> <p>2. B. (2): For the H85 odorant blends the target level range is 3.0 to 6.0 LBS/MMSCF.</p> <p>2. C.: Word change, "saturation" for "concentration".</p> <p>2. C.: When using TBM 80/20 blends, the odorizers are adjusted to maintain an odorant concentration level near 1.0 Lbs/MMSCF. When using H85, the level is near 5.0 Lbs/MMSCF.</p> <p>Revised to address odorant blends used at AIC. Odorant blends have different target odorant concentration targets.</p> <p>2. E.: Supplemental odorizer would also be used for pipeline pickling or where supply sources may not provide adequate odor intensity.</p> <p>2. F.: Added the word "targeted" to injection rates.</p> <p>Odorization SMR Team is now working on pipeline pickling procedures. A supplemental odorizer may be required where long sections of new pipe is being installed.</p> <p>3. Odorization Intensity Sampling: Added Intensity</p>	<p>January 1, 2016</p> <p>October 15, 2018</p>
--------	---	--

ODOR 2.02	<p>Odorization Operations</p> <p>Throughout this section the word "standard" has been added to cubic feet, "standard cubic feet" and to "MMSCF".</p> <p>2. Odorization Location</p> <p>2. B.: Word change, odorization equipment replaced supplemental odorizer equipment.</p> <p>3. Odorizer Equipment</p> <p>3. C.: Word change, "must" replaced "should be capable of". Odorization equipment must introduce odorant into gas stream without wide variation in the level of odorant. The language closely matches 192.625.</p> <p>3. D.: Odorizer may be programmed with alarm limits, remote control and fault indications. Added "remote control".</p>	<p>January 1, 2016</p> <p>October 15, 2018</p>
-----------	---	--

4. Odorization Operations and Inspection

4. B.: Added the word verbally. When Gas Control detects an AOC they will verbally contact the appropriate Gas Tech Supervisor for consultation and instruction or may dispatch a GTS Technician.

4. B. (2): Added the word verbally. The GTS Technician will verbally contact Gas Control to notify them of the results of the investigation and follow-up action.

Due to the importance of an AOC situation, the Odorization SMR team wanted to make sure the contacts were verbal and not phone messages or email.

4. C. New: When GTS Technicians are responding to an abnormal operations on odorizer equipment that is not remotely monitored, they are expected to document the same information as required for remotely monitor equipment.

4. D.: Clarified that all in-service odorizers shall be inspected at least monthly.

Added the inspection will include checking for odorant leaks and atmospheric corrosion on the piping connected to the odorizer. Inspection is documented in ClickMobile.

4. E.(2): "intensity test" replaced "sniff test"

4. F. (4): Revised AIC's target odorization rates based on the blend of odorant being utilized. For 80/20 blend the target rate is 1 Lbs/MMSCF. For the H85 blend the target is 5 Lbs/MMSCF.

4. F. (6): If calculated usage is less than 0.50 or greater than 1.25 Lbs.MM/SCF for 80/20 blends a warning message will be displayed in Maximo.

4. F. (7): If calculated usage is less than 3.0 or greater than 6.0 Lbs.MM/SCF for H85 blends a warning message will be displayed in Maximo.

Once Maximo is unlocked it will be update to reflect this change.

4. F. (8): Added the word verbally. When the calculated odorant usage rate falls outside the compliance ranges, the GTS Technician is to verbally notify the GTS Supervisor.

4. F. (9) (e) II.: Word changes, Increase odorizer operational inspection frequency.

5. Liquid Odorant Tank to Tank Transfer

5. A. (1): Added: Mercaptan liquid than lighter than water and the vapor is heavier than air.

5. A. (6): Package group for shipping papers change to Group 1/2/3 from Group 3

5. A. (7): Identified the shipping paper template is in ODOR 4.

UNCONTROLLED IF PRINTED

5. A. (10): Expanded the PPE to include non-permeable gloves and eye goggles when working on or near pressurized odorant lines. Additional PPE that may need to be considered are respirator with organic cartridges and non-static clothing.

5. B. Procedures to be followed when transferring odorant.

5. B. (3): Added recommended hoses that should be used for the transfer.

5. B. (9): Clarified that a pressure regulated standing pilot flame should be used at the flare to ensure complete incineration of odorant vapor and possible hydrocarbons.

5. B. (11): New, a closed-loop odorant transfer methods are recommended.

5. B. (12): New: Commercial odorant delivery may incorporate compression or vacuum to transfer the odorant between target vehicle and delivery vehicle.

5. B.(17): New: Clothing may become permeated or contaminated with the odorant so personnel should avoid public areas.

6. Records

6. A.: Monthly inspection and odorization rates are maintain in Maximo for a minimum of 5 years which is a change from 3 years.

Inspection records on transmission lines must be kept for a minimum of 5 years per 192.709

Majority of the revision above were made by the Odorization SMR team to bring AIC operations in line with the new AGA Odorization Handbook. The GTS Supervisors and Technician are the only ones impacted by these revisions.

ODOR
2.03

Odorant Intensity Testing

1. Definition of odorant intensity was added to GLOS.

2. A.: Expanded reference link

3. Intensity Test Instruments and Readings

3. E.: The "sniffs the sample" was replaces with "then uses their nose to rate the intensity of the sample.

3. I.: When the intensity reading is outside the readily detectable range, it shall be verbally reported immediately to the Gas Supervisor and the GTS Supervisor.

Due to the importance of these odorant intensity tests, the Odorization SMR team wanted to make sure the contacts were verbal and not phone messages or email.

3. I. (1) and (2): Daily intensity test replaces Daily readings.

Janu-
ary 1,
2016

Octo-
ber
15,
2018

3. J. (1): Added other strong smells could contribute to olfactory fatigue.

3. K.: When the customer is available, they may be asked to perform a threshold and readily detectable test. The results of customer's test will be documented.

Replaced the word "test" with "threshold and readily detectable test" and added the documentation.

4. Employee Threshold Testing

4. B.; Word change, "attending employee" replaces "other employee".

5. Selection of Odorant Intensity Test Sites

5. B.: In addition to the size and configuration of the odorized system and the location of the delivery points, site locations will also depend on locations at end of mains.

SMR Team added end of main as another consideration for selection of intensity test site.

5. D. (3): Word changes, masking replaced dilution and disguising of gas smell replaced masking of odorant.

5. D. (5): Revised to reinforce that test sites should not be at regulators stations because the soft parts in the station equipment absorbs odorant that could may deceive of bias the intensity tests.

6. Snif Tests

6. A.: Definition of snif tests was added to GLOS

6. C.: Added, "use their nose to sniff"

6. D.: Revised; The gas field personnel shall verbally and immediately contact their Supervisor or other AIC management personnel during a suspected occurrences of either over-odorized, strong smelling gas, or under-odorized, weak smelling gas, that is not readily detectable.

6. E.: Added the word immediately, Gas Supervisor will immediately schedule odorant intensity checks to determine the actual intensity value of the gas' smell.

Odorization SMR felt the importance of odorant intensity tests needed to strengthen and that immediate verbal contact and action must be taken when there is a suspected problem.

7. Records

Odorant intensity test records shall be retained in Maximo for a minimum of 5 years which is a change from 3 years.

ODOR
2.04

Emergency Response - Replaces Deodorizing Agents
This sections includes emergency response guidelines related to liquid odorant spills, vaporized odorant releases,

October 1, 2011
October

UNCONTROLLED IF PRINTED

	<p>and low/high odorant intensity situations. It contains; Immediate, continuous action; Uncontrolled Release of Liquid or Vaporized Odorant; Corrective Action to Minimize Event and what actions should be taken when the Odorant Intensity is outside the O&M Threshold of 0.1% to 0.8% Gas-in-Air.</p> <p>This section should be reviewed in depth by those who handle odorant.</p>		15, 2018
ODOR 4	<p>Forms and Reference Materials</p> <p>Forms: Updated</p> <p>Form 02 - Ameren Shipping Paper - Odorant</p> <p>Reference Materials</p> <p>Added: Form 03 - Odorant Event Report 8-28-2018</p> <p>Reference 11 - ODOR Handy plus Manual Version August 2011</p> <p>Reference 12 - Becker ACD-300 Charcoal Deodorizer</p>	January 1, 2016	October 15, 2018
POLY 0	<p>Table of Contents</p> <p>Removed POLY 2.03 - Heat Fusion- Was incorporated this section into Butt Fusion in January, 2018.</p>	January 1, 2018	October 15, 2018
POLY 1	<p>Requirements</p> <p>7. Minimum Bending Radius</p> <p>7. B. (3): Updated the table by adding the Pipe OD, and SDR rating for the MDPE and HDPE.</p> <p>8. Weak Link</p> <p>8. B. (1) (f): added "pull plug", not required when the pipe is pulled by hand.</p> <p>8. C. Mechanical Weak Link</p> <p>Updated the MDPE and HDPE tables with the Maximum Tensile Load and corrected the Part Numbers for the Swivels and Replacement Pins.</p> <p>Gas Standards provided the update information. Max Tensile Load was revised based on 120°F pipe temperature and the listed weak links have break points do not exceed the maximum tensile loads.</p> <p>11. Damage During Construction</p> <p>11 D.: Update reference link REPR 1 5. PE Pipe Repair</p>	September 1, 2016	October 15, 2018

POLY 2.01	<p>Design Pressure</p> <ol style="list-style-type: none"> 1. Stock Coded PE Pipe 2. B. Note 2.: Added 1/2" CTS whose design pressure is also calculated using a 120° F Temperature Factor. 3. Hydrostatic Design Basis 3. A.: Updated Perfection Pipe's HDB Value at 140° F for PE 2406/2708 to 800 psi. 3. B. Note 2.: Clarification that Design Temperature of 73° F is used for buried pipe with a short term above ground or uncovered exposure during testing. 	April 1, 2013	Octo- ber 15, 2018
PRES 2.04	<p>Overpressure Reporting</p> <ol style="list-style-type: none"> 1. A.: When the MEP is exceeded the gas field personnel shall immediately contact their Supervisor. 1. B.: Added that Gas Tech Services are also to be contacted immediately by the Supervisor. 1. C.: New: When the MEP is exceeded on transmission facilities a Gas Transmission MAOP Exceedance Report must be filed with PHMSA within five (5) calendar days of the occurrence. <p>Exceeding a system's MEP requires immediate action to correct the situation. In some instances, it will trigger a reporting requirement to the Regulatory agencies.</p>	Janu- ary 1, 2016	Octo- ber 15, 2018
PTST 1	<p>Requirements</p> <ol style="list-style-type: none"> 2. Test Medium 2. A.: Removed the Test Medium Limitation Table since it was a duplicate to the one in PTST 2.02 Strength Test. Added a reference to PTST 2.02 for the limitations. 4. Design MAOP 4. C.: Replaced the minimum/maximum test pressure valves with references to the PTST 1 Tables which contains that information to avoid confusion or possible conflicts. 4. D.: Added that Gas Engineering will evaluate and determine what action needs to be taken when the maximum test pressure is exceeded. 6. Plastic Pipe Testing 6. E.: Removed the maximum test pressure for PE pipe sentence since the information is contained in PTST1 Table A and PTST1 Table B. 	Janu- ary 1, 2018	Octo- ber 15, 2018
PTST 1 Table A	<p>Service Lines - Less than 2" Diameter, Plastic or Steel</p> <ol style="list-style-type: none"> 1.: Added, and gauge tap type fittings/assemblies 	Sep- tem-	Octo- ber

	<p>Clarify that gauge type connections are to be tested the same as services since they are the same fitting used for farm tap services.</p> <p>Table A: Added HDPE for 60 psig Design MAOP.</p> <p>Since HDPE has a higher Design MAOP than MDPE, it is acceptable to install HDPE in 60 psig MAOP systems. A check with Integrity Management found there isn't a problem with incorporating the HDPE in a MDPE system and the HDPE can be tested to the same requirements as MDPE.</p> <p>Change Max. Test Pressure for both Design MAOPs of 60 or 100 psig to 175 psig. The A.Y. McDonald meter valve has a maximum operating pressure of 175 psig. The A. Y. McDonald valve is the most common valve installed on services.</p>	ber 1, 2016	15, 2018
PTST 1 Table B	<p>Plastic Main - All PE Pipe Sizes thru 8" with Design MAOP 100 psig or Less</p> <p>Table B: Added HDPE for 60 psig Design MAOP.</p> <p>Since HDPE has a higher Design MAOP than MDPE, it is acceptable to install HDPE in 60 psig MAOP systems. A check with Integrity Management found there isn't a problem with incorporating the HDPE in a MDPE system and the HDPE can be tested to the same requirements as MDPE.</p> <p>Changed Max. Test Pressure for 60 psig Design MAOP to 180 with a Note that 8" MDPE has a Max Test Pressure of 150 psig.</p> <p>Maximum test pressure is based on the design pressure of the PE pipe and 192.513 states the maximum test pressure cannot exceed 3 times the design pressure.</p>	Sep-tem-ber 1, 2016	Octo-ber 15, 2018
PTST 1 Table C	<p>Steel Main - All Steel Pipe Sizes thru 30" with Design MAOP < 100 PSIG</p> <p>Changed the Max Test Pressure for Design MAOP ≤60 PSIG to 180 psig from 120 to be consistent with PTST 1 Table B.</p>	Sep-tem-ber 1, 2016	Octo-ber 15, 2018
PTST 1 Table E	<p>Fabricated Unit/Assemblies or Short Sections of Pipe</p> <p>Removed; pressure gauge tap, blow down stacks, equalizer valve setup, pressure recording connections and by-pass connections.</p> <p>These type fittings are to be tested in accordance with PTST 1 Table A.</p> <p>Added HDPE for 60 psig Design MAOP.</p>	Sep-tem-ber 1, 2016	Octo-ber 15, 2018

Changed Max. Test Pressure for 60 psig Design MAOP to 180 with a Note that 8" MDPE has a Max Test Pressure of 150 psig.

Consistent with PTST 1 Table B

PTST 2.04	Nitrogen Pressure Testing 3. Cylinder Requirements 3. C. (1) & (2): Correction to 3 inch pipe. 12 inch pipe was erroneous entered in January 1, 2018.	January 1, 2018	October 15, 2018
PUBL 2.01	Public Notifications 6. Records 6. B.: Paradigm has replaced NIPA and SIPA	January 1, 2018	October 15, 2018
PUBL 2.02	Liaisons With Fire, Police and Public Officials 2. Periodic Contact 2. D.: Paradigm has replaced NIPA and SIPA	January 1, 2018	October 15, 2018
PURG 0	Table of Contents PURG 2.01: Changed the following: 4. Purging Transmission Lines and High Pressure Distribution Mains 5. Purging of Gas with Air During Abandonment	January 1, 2016	October 15, 2018
PURG 2.01	Purging Methods 2. Pre-Purge Activities 2. D.: Correction, services shorter than 500 feet that can be purged through the service riser. 3. Purging Transmission Lines and High Pressure Distribution Mains Transmission Lines and High Pressure Distribution Mains have been used throughout this section. 4. Purging of Air with Gas 4. C.: Clarified that when purging a service line with an EFV, the meter valve should be opened slowly to allow the air to be purged without tripping the EFV. Slowly opening the valve minimizes the gas flow thereby not exceeding the EFV's trip flow value. 4. D.: Revised: When purging from air to gas, purge is complete when CGI readings reach ninety percent (90%) Gas-in-air or greater and the smell of gas is present.	January 1, 2018	October 15, 2018

(1) Alternatively, purging may be considered complete at 90% Gas-in-Air when Engineering has prepared a pipeline conditioning (pickling) plan or

(2) Pipeline contains un-odorized gas and is not required to be odorized.

The Odorization Team wanted to provide more guidance as to when a purging the air from the pipeline is complete. This takes into account conditioning of new pipelines to ensure odorized gas is passing through the pipe and the odorant is not being absorbed into the new pipe. Engineering will evaluate projects to determine when a pipe conditioning plan will be required.

5. Purging of Gas with Air During Abandonment

5. A.: Clarification this section addresses abandonment of transmission line, distribution main or applicable service line.

5. C.: Clarification that the 2% LEL or less is measured with a CGI.

5. E.: New, Added a table that shows which gas facilities; a) require a Purge Plan, b) require purging to be documented and c) how to document the purge was completed.

Documenting that an abandoned facilities has been purged is a new requirement in most cases. This table was developed to clarify what documentation is required.

10. Monitoring Purge

10. F.: Deleted the sentence on testing gauges.

Expanded some of the reference links throughout the document.

REPR 0	Table of Contents	Janu- ary 1, 2018	Octo- ber 15, 2018
	REPR 4 Reference Materials added		
	Ref 03 - Plidco Storage and Inspection Instructions		
	Ref 04 - Plidco Installation Split + Sleeve 2016		
REPR 1	Requirements	Janu- ary 1, 2018	Octo- ber 15, 2018
	1. Objective		
	1. J.: Revision on the Make Safe Repair; Permanent repair shall be completed within 90 calendar days except for compression couplings which is 30 calendar days, see REPR 2.01. This does not apply to a Class 1 leak within 5 feet of a foundation which shall be permanently repaired at time of discovery.		
	Clarifies that permanent repair for leaking compression coupling greater than 5 feet from a foundation has to be made within 30 calendar days. Leaking compression coupling		

within 5 feet of a foundation is considered a Class 1 leak which has to be permanently repaired at time of discovery.

5. PE Pipe Repair

REPR 1 Table 3: MDPE and HDPE Pipe Repair Methods

Correction, EF Repair Saddle can be used on Pipe Defects greater than 10% wall thickness. This is consistent with language in 6. D. (1).

Updating the Table was missed with the January 1, 2018 O&M Update.

Added "leak detection equipment" where ever "testing or checking for leaks with leak detection fluid" was referred to within the document.

Expanded reference links throughout the document.

REPR
2.01

Compression Couplings

Throughout this section, below grade, has been added to clarify this O&M section addresses below grade compression couplings. In addition, calendar days was clarified throughout this section to be consistent with REPR 1 1. J.

De-
cem-
ber 1,
2014 Octo-
ber
15,
2018

2. Main Repair Methods for Below Grade Compression Couplings

2. C. Steel to Steel

New: (1) If the compression coupling is within five (5) feet of a foundation wall:

(a) Tighten and encapsulate the compression coupling with a full encirclement welded split sleeve or

(b) Remove the coupling and replace with a new section of pipe connected by an approved welding procedure.

2. C. (2): Added, If the compression coupling is greater than 5 feet from a foundation wall,

O&M did not address the situation of a leak compression coupling on a main that is within 5 feet of a foundation. The same requirements as under a service line within 5 feet should apply.

3. Service Line Repair Methods for Below Grade Compression Couplings

3. C. Steel to Steel

3. C. (4) (a): Corrected the reference to REPR 2.02 2. C. (2).

5. Testing of Repairs

5. D,: Added "leak detection instrument" and another means for check for leaks.

REPR 3.02	Dresser Reinforcing Sleeves Updated part numbers and added new Style 110 and Style 220 Reinforcing Sleeves.	January 1, 2013	October 15, 2018
REPR 4	Forms and Reference Materials Added Reference 03 - Plidco Storage and Inspection Instructions Reference 04 - Plidco Installation Split + Sleeve 2016	January 1, 2014	October 15, 2018
SERV 0	Table of Contents SERV 3.08 Farm Tap, Double-Cut, DOT Inspectable, (20% SMYS Transmission) SERV 4: Added Reference 01 - Transmission Map - 20% SMYS MAOP	April 1, 2017	October 15, 2018
SERV 2.02	Excess Flow Valves or Manual Shut-Off Valve This change was distributed on April 30, 2018. 1. General 1. D. Replaced service includes: (1) Replacement of the service tee or the fitting that connects the service line to the main, or (2) Replacement of the service line from that service tee or fitting to the service riser, or (3) Replacement of a section of the service line near the main, where an EFV is typically installed 1. E. An EFV is not required when the section of the service line being replaced is far away from the main or source of gas. Revised language closely matched Part 192.383 and removes the previous requirement for installing an EFV whenever the main is uncovered to shut-off gas on the service line. 1. H.: Grammatical change to make it clear if existing customers meet specific requirements, an EFV will be installed on their service line. 2. Residential Service Requirements 2. B. Multi-family residences shall have a properly sized EFV installed when there is one available and approved by AIC. If an EFV is not available, and manual service line shut-off valve shall be installed. In order to simplify and eliminate confusion, the 1,000 scfh criteria was removed.	April 1, 2017	April 30, 2018

2. C.: Clarified that a 3/4 inch steel EFV shall be installed on the high pressure service line of a residential farm tap if there is one available and approved by AIC.

2. D. (4): Added "approved by AIC".

3. Commercial Service Requirements

3. A. Each single service lines to a single commercial customers shall have a properly sized EFV installed when there is one available and approved by AIC. If an EFV is not available, and manual service line shut-off valve shall be installed.

3. C. Each single service lines to a multi-commercial customers shall have a properly sized EFV installed when there is one available and approved by AIC. If an EFV is not available, and manual service line shut-off valve shall be installed.

In order to simplify and eliminate confusion, the 1,000 scfh criteria was removed.

3. E.: Clarified that a 3/4 inch steel EFV shall be installed on the high pressure service line of a commercial farm tap if there is one available and approved by AIC.

3. E. (1): On all commercial farm taps, a properly sized EFV shall be installed on the primary service line if there is one available and approved by AIC.

In order to simplify and eliminate confusion, the 1,000 scfh criteria was removed.

3. G. (4): Added "approved by AIC".

8. EFV Sizing

8. F. (3): Added a higher capacity 1 inch CTS EFV, UMAC Series 2600.

SERV
2.03

Farm Tap Installation

1. General

1. B.: Added "and DOT classification" as another determining factor on which farm tap is to be installed. 1. C.: New, Double Cut DOT Transmission farm taps should be installed on all new and replaced services where the MAOP of the main is equal to or greater than 20% SMYS (DOT Transmission). A map of DOT Transmission mains is in SERV 4 -Transmission Map - 20% SMYS MAOP. 2. Standard Installation

2. A.: Added "and DOT line classification" for sizing relief valve on a farm tap.

2. B. (3): Added a Double-Cut DOT Transmission Farm Tap (Inlet MAOP up to 1000 psig) - SERV 3.08

April
1,
2017

October
15,
2018

- 2. D.: Added: On DOT Transmission farm taps the second cut regulator set point is 20 psig. The second cut 1805 relief will be set at 30 psig
- 2. E.: Added: Note: All DOT farm taps should be set as double cuts.
- 2. I.: Added SERV 3.08 Double-Cut DOT Transmission
- 3. Location
 - 3. D.: Added, Particular consideration should be given to protect DOT Transmission farm taps.

Above changes made to comply with a new PHMSA rule 192.740 requiring the pressure regulating equipment (farm tap) connected to a transmission line be inspected every three years. New farm tap design was required to allow inspection without disrupting service to the customer.
- 4. Testing
 - 4. C.: Added "leak detection instrument" as another means for checking for leaks.
- 5. Inlet Valves
 - 5. A.: Added "and DOT Transmission" to the list of farm taps.
 - 5. B. (1): Added "SERV 3.08 DOT Transmission farm tap".
- 7. Farm Tap Capacity Tables
 - 7. D. New: Double Cut DOT Transmission farm tap -2nd Cut 627, 1/8" orifice, 20 psig set point capacity at 100 psig inlet = 1810 scfh.

SERV 3.08	Farm Tap - Double-Cut, DOT inspectable (20% SMYS Transmission) Standard design for an inspectable farm tap.	New	October 15, 2018
SERV 4	Forms and Reference Materials Added: Reference 01 - Transmission Map - 20% SMYS MAOP	De- cem- ber 1, 2014	Octo- ber 15, 2018
STLP 2.01	Design Pressure 1. Design Formula 1. Corrected the reference numbers for Design Factor, Longitudinal Joint Factor and Temperature De-rating Factor 7. Steel Pipe Stock Code Table Added three sizes of bare steel pipe: 12 inch x 0.500 w.t.; 16 inch x 0.500 w.t. and 20 inch x 0.500 w.t.. All are minimum 52,000 psi, maximum 56,000 psi Yield Strength.	Janu- ary 1, 2018	Octo- ber 15, 2018

TURN 1	<p>Requirements</p> <p>1. C. Removed NFPA 54 is available electronically through WinDot.</p> <p>WinDot is no longer support on Webdesk. Individual annual subscription is now required to access WinDot electronically.</p>	January 1, 2016`	October 15, 2018
TURN 2.01	<p>Residential - Small Commercial Customer</p> <p>2. New Service Connect</p> <p>2. B. Added an A, A gas meter should be installed at the same time as the service.</p> <p>When a multi-meter set is being installed, only the meter serving a known needs to be installed.</p> <p>4. Existing Service Connect</p> <p>4. A.: Added instructions if voltage is detected on a gas meter with a reference link to CORR 2.17 2. A. AC Voltage at Customer Meter Set</p>	January 1, 2016	October 15, 2018
UPRT 0	<p>Table of Contents</p> <p>Correction:</p> <p>3. Increasing MAOP Above 100 PSIG</p> <p>UPRT 4 Forms and Reference Materials</p> <p>Updated MAOP Uprating Plan Form REV 10-01-2018</p>	June 1, 2010	October 15, 2018
UPRT 1	<p>Requirements</p> <p>2. Increasing MAOP Up to 100 PSIG</p> <p>2. C.: New; If the system contains PE pipe, the PE pipe has to be tested at 1.5 times the proposed MAOP. If there are no test records that substantiate the proposed MAOP, the PE pipe must be tested prior to uprating.</p> <p>Added to comply with Part 192.619 (a) (2)</p> <p>2. J.: Added that at the pre-job meeting procedures should be approved. At a minimum, Engineering (Division/GTE), Operations (Division/GTS) and Gas Compliance should be represented at the meeting.</p> <p>This is to ensure that uprating operations has been thoroughly reviewed and all parties understand how the procedures are to be followed.</p> <p>3. Increasing MAOP Above 100 PSIG</p> <p>3. D.: Added that at the pre-job meeting procedures should be approved. At a minimum, Engineering (Division/GTE), Operations (Division/GTS) and Gas Compliance should be represented at the meeting.</p>	January 1, 2018	October 15, 2018

Consistent with the above section.

UPRT 4	<p>Forms and Reference Materials</p> <p>Updated: MAOP Uprating Plan Form REV 10-01-2018.</p> <p>Expanded to provide significantly more detail and documentation of the uprating planning and process.</p>	January 1, 2011	October 15, 2018
VALT 2.01	<p>Inspecting Vaults and Pits</p> <p>2. Vault/Pit Hazard Assessment and General Entry Requirements</p> <p>2. D.(1): Correction, acceptable oxygen level is between 19.5% and 23.5%</p> <p>4. General Vault and Pit Inspection Items</p> <p>4. A.: Revised, if leak is found, it should be classified and repaired in accordance with LEAK 2.04 Leak Classification and Surveillance.</p> <p>SMR Team said all leaks in a vault are not necessarily a Grade 1. Some could be small fizzer leaks that is not an immediate hazard. A leak classified as a Grade 2 doesn't have to be repaired when discovered. Grade 2 has to be repaired within 6 months.</p>	January 1, 2016	October 15, 2018
VALV 0	<p>Table of Contents</p> <p>VALV 4: Reference Materials</p> <p>Added Reference 8 - QS-2000A Operations and Maintenance Manual</p>	January 1, 2016	October 15, 2018
VALV 4	<p>Forms and Reference Materials</p> <p>Added Reference 8 - QS-2000A Operations and Maintenance Manual</p>	January 1, 2016	October 15, 2018
<p>The following NDT procedures were given to the NDT Contractors in January before construction projects got kicked off</p>			
WELD 2.06	<p>Radiographic Testing</p> <p>3. Radiographic Testing Personnel</p> <p>3. A.: Added Level I since all radiographic testing personnel are required to be certified.</p> <p>3. A. (1): Revised, Level I and Level II are required to be certified every 3 years and Level III are certified every 5 years. This is per API 1104 20th Edition which has been incorporated by reference in Part 192.</p> <p>3. B.: Revised, to require trainees who are assisting Level II or Level III radiographer to provide AIC Gas Compliance</p>	January 1, 2018	January 17, 2018

with a statement indicating satisfactory completion of their employer's training.

Removed the language requiring a trainee to provide the same documentation as Level I, Level II and Level III since trainees are not certified.

6. Radiographic Quality

6. A. (2): Removed the Acceptable examples of Class 1 film.

WELD 2.07	<p>Magnetic Particle Testing</p> <p>3. Magnetic Particle Testing Personnel</p> <p>3. A.: Added Level I, Level II and Level III.</p> <p>3. A. (1): Revised, Level I and Level II are required to be certified every 3 years and Level III are certified every 5 years. This is per API 1104 20th Edition which has been incorporated by reference in Part 192.</p> <p>3. B.: Revised, to require trainees who are assisting Level II or Level III MT personnel to provide AIC Gas Compliance with a statement indicating satisfactory completion of their employer's training.</p> <p>Removed the language requiring a trainee to provide the same documentation as Level I, Level II and Level III since trainees are not certified.</p>	Janu- ary 1, 2018	Janu- ary 17, 2018
WELD 2.08	<p>Liquid Penetrant Testing</p> <p>3. Liquid Penetrant Testing Personnel</p> <p>3. A.: Added Level I, Level II and Level III</p> <p>3. A. (1): Revised, Level I and Level II are required to be certified every 3 years and Level III are certified every 5 years. This is per API 1104 20th Edition which has been incorporated by reference in Part 192.</p> <p>3. B.: Revised, to require trainees who are assisting Level II or Level III PT personnel to provide AIC Gas Compliance with a statement indicating satisfactory completion of their employer's training.</p> <p>Removed the language requiring a trainee to provide the same documentation as Level I, Level II and Level III since trainees are not certified.</p>	Janu- ary 1, 2018	Janu- ary 17, 2018
WWBG 0	<p>Table of Contents</p> <p>WWBG 2.02 3. Changed to PPE Equipment Specifications</p>	Janu- ary 1, 2018	Octo- ber 15, 2018
WWBG 2.02	<p>Personnel Protective Equipment</p>	Janu- ary 1, 2016	Octo- ber

1. E. Table listing the required PPE, Level 1 and Level 2. has been updated based on information from a Safety Supervisor who had done the research on the items.

2. Specialized Tools and Equipment SharePoint Site

2. A.: Added the link to the SharePoint Site

2. B.: Added, PPE items that are currently in use, that meet the specifications in this section and continue to function as designed may continue to be used until such time they are replaced.

Clarifies that existing PPE that is not listed in the table can continue to be utilized as long as it meets the required specifications.

3. PPE Equipment Specifications

3. A.: A few additional specifications were added for Level 1 Flash Suit and Goggles.

3. B.: Added Level 2 Insulated Hood should have a minimum rating to 47 cal/cm².

Safety Supervisor provided the specifications.

CHANGE SUMMARY

January 1, 2018

Change Summary January 1, 2018

Docu- ment	Change Summary	Previ- ous Docu- ment Dated	Cur- rent Docu- ment Dated
SIGNIFICANT OPERATIONAL REVISIONS			
<p>ABND 2.01</p>	<p>Abandonment of Gas Facilities</p> <p>General - Added this section</p> <p>1. A. This section applies to abandonment of transmission, high pressure distribution and distribution mains and services including regulator stations, farm taps, and inside meters.</p> <p>1. B. This section addressing abandoning main and services as a unit requiring engineering personnel to prepare a project specific procedures. This was brought over from ABND 2.02 which is being removed.</p> <p>1. C. This section addressing abandonment of transmission or high pressure distribution facilities requiring Gas Tech Engineering to prepare abandonment procedures. This was brought over from ABND 2.03 which is being removed.</p> <p>1. D. This section addresses oily hydrocarbons or PCB's that may be found in facilities being abandoned. This was brought over from ABND 2.04 which is being removed.</p> <p>1. E. This section references ABND 2.08 if mercury is encounter when abandoning a facility.</p> <p>General section incorporated the topics that were originally in ABND 2.02, 2.03, 2.04.</p> <p>2. Mains</p> <p>2. A General</p> <p>2. A. (1): New section added requiring identifying all sources of gas feeding into the section of main to be abandoned and the installation of pressure gauges to monitor upstream and downstream pressures.</p> <p>Re-enforcing the importance of monitoring pressures when abandoning sections of main to avoid an unplanned outage.</p> <p>2. A. (3): Revised, The main to be abandoned shall be purged of gas until a combustible concentration no longer exists. Refer to ABND 2.01 for purging procedures.</p> <p>2. A. (4): Prior to any cutting on steel pipe an electrical bond should be installed. See ACIG 2.01 3. Welding and Other Hot Work.</p>	<p>De- cem- ber 1, 2014</p>	<p>Janu- ary 1, 2018</p>

UNCONTROLLED IF PRINTED

Revised to ensure work is going to be performed in a combustion free environment and to prevent a source of accidental ignition.

2. C. Steel Mains

2. C. (1): Threaded cap has been approved for capping steel main smaller than 2 inch.

Gas Standards Committee agreed that threaded caps are acceptable on steel lines small than 2 inch regardless of their operating pressure.

3. Services

3. D Steel Services

3. D. (5): Threaded cap has been approved for capping steel service lines smaller than 2 inch.

Gas Standards Committee agreed that threaded caps are acceptable on steel lines small than 2 inch regardless of their operating pressure.

3. D. (6): New section that addresses using a capped pipe or properly size solid plug for capping a steel service tee with a compression outlet. If the solid plug is not restrained with a cap the outlet should be strapped to prevent movement of the capped pipe or plug.

The O&M had not addressed this style of service tee. The information was provided by personnel experienced in abandoning this style of tee.

3. D. (8): New section which contains information and stock codes for the Mueller Steel Abandonment Cap for H-17800 Curb Stop Tee.

4. Joint Abandonment of Mains and Services

New section added to ABND 2.01 that incorporated information previously on ABND 2.02. Expanded the information that should be included in the abandonment plan when main and services are abandoned as a unit.

Additional information was added to avoid an unplanned service outage.

**ABND
2.06**

Abandonment of Vaults

1. A: New, if vault/pit has a concrete/solid floor, a hole should be bust out to provide a drain.

1. B.: New, the vault/pit should be filled with soil, sand, crushed stone with the top 12 inches being compacted soil.

1. C.: New, if the vault/pit was located in a hard surface area, the hole should be capped with the appropriate hard surface material.

February 1, 2010

January 1, 2018

ACIG 2.01	<p>Work Area Protection</p> <p>2. Tools and Equipment</p> <p>2. D.: Added, Vapor extraction equipment and blowers (VEU) which may be used to move air containing natural gas should be located in a work area where the gas concentration is safe for open ignition sources and the VEU is equipped with preventative safety devices to ensure explosive levels of natural gas are not pulled through the equipment. The equipment should be operated in accordance with the manufacturer's operating instruction.</p> <p>Vapor extraction equipment (VEU) is a new piece of equipment now being used in AIC as a means of purging natural gas from the soil.</p>	<p>January 1, 2014</p>	<p>January 1, 2018</p>
<u>BORE</u> 2.02	<p>Boring Location Criteria</p> <p>3. Prior to Beginning Operations</p> <p>3. B.: Clarifies that exposing a facility within the tolerance zone means by hand digging or vacuum excavating. The pot holes should extend 18 inches either side of the locator's marks.</p> <p>JULIE requires exposing facilities by means of hand digging or vacuum excavation and these excavation should extend across the tolerance zone.</p> <p>6. Directional Drilling Operations</p> <p>6. M.: Added that if the bore hole bit does not provide a bore hole that is approximately 1.5 times the pipe diameter or greater, the hole must be back reamed to accommodate and permit free sliding of the pipe into the bore hole.</p> <p>Provides guidance as to when the bore hole has to be back reamed. Current language suggest all bore holes have to be back reamed.</p>	<p>January 1, 2016</p>	<p>January 1, 2018</p>
CNTS 2.01	<p>Surface Subsidence Areas</p> <p>4. Active Mining Operations</p> <p>4. D. (5): Added table with stock codes for Flex Braided Connectors used to connect meter set to customer piping.</p> <p>Connectors are used in areas with mine subsidence.</p>	<p>December 1, 2014</p>	<p>January 1, 2018</p>
<u>CONS</u> 1	<p>Requirements</p> <p>3. Gas Construction Work Performed by Ameren Illinois Crews or Contract Crews - Add Contract Crews</p> <p>3. Since Work Performed by Contractors was merged in with Work Performed by Ameren Illinois Crews, Construction Services Supervisor or Construction Inspector have been added</p>	<p>December 1, 2014</p>	<p>January 1, 2018</p>

throughout this section anywhere Gas Supervisor was referenced.

Ameren crews and contractor crews are required to meeting the requirements and follow the same procedures so there was no need to list separate them.

3. B.: Clarification that the Gas, Construction Services Supervisor or Construction Inspector are responsible for ensuring and verifying that all of listed requirements are being met. Ensuring and verifying that all records and maps are being documented and maintained thoroughly and accurately and that the As-Built construction packet is complete and the information is correct before forwarding the packets to the Posters was added.

Designated who is responsible for ensuring that work is being done properly and the all required documentation is being maintained in the job packet for retention.

CORR 1	<p>Requirements</p> <p>14. Pipeline Facilities That Need to Be Painted</p> <p>14. C. Painting Facilities</p> <p>14. C. (2): Added, Stainless steel control lines, fittings and valves should not be painted.</p> <p>Gas Tech Services does not want the stainless steel lines and fittings painted.</p>	<p>April 1, 2017</p>	<p>January 1, 2018</p>
CORR 2.02	<p>Anode Requirements</p> <p>1. General</p> <p>1. F.: Additional instructions when installing an anode. Pipe-to-Soil reading needs to be taken after the anode has activated. If the P/S reading does not increase immediately, water should be added and time allowed for the anode to activate.</p> <p>Anodes must be activated in order to be affective.</p> <p>1. G. New instructions if after activation, the P/S reading is below -0.950 volts, the Corrosion Control personnel should be contacted before backfilling the anode and entering the deficient reading into ClickMobile.</p> <p>This is to avoid unnecessary work orders being generated through Maximo. CP Tech may have other instructions..</p>	<p>April 1, 2017</p>	<p>January 1, 2018</p>
CORR 2.03	<p>Coatings</p> <p>1. Approved Coatings</p> <p>Replaced text with tables showing the approved coatings for girth welds on direct bury and directional drilling installation. Team felt tables would be easier to follow.</p> <p>1. A (1) Direct Bury Installation</p>	<p>July 1, 2016</p>	<p>January 1, 2018</p>

1. A. (1) (b): Approved girth weld coatings are specified for various ranges for pipe diameter; less than 2", 2" to 12" and 12" and larger.

1. A. (2) Directional Drilling Installation

Approved girth weld coatings are specified for various pipe diameter ranges; less than 2", 2" to 6" and 6" and larger

Links were added to the instructions for each of listed approved coatings.

1. C. Coating Repair

1. C. Added 2 tables, (1) Pipe Coating Repairs and (2) Fitting Coating Repairs

Provides more guidance on how to repair damage to existing pipe and fitting coatings.

1. E. Fittings

1. E. (3): New, Irregular shaped fittings and those with bolts should be coated with wax tape and that profiling material may be necessary prior to the wax tape.

Clarification on how irregular shaped fittings should be coated.

1. F Soil to Air Interface Zone

1. F. (1): Revised the wrapping instructions, terminate the wrap with a good tight seal near the bottom of the meter valve.

Previously it said to wrap to the bottom of the meter valve but comments from the field said that it was difficult to get a good seal if you wrapped to the bottom of the valve.

1. F. (4): Added a requirement that if approved below grade coating extends above grade, the coating shall be over coated with a UV resistant coating, cold applied tape, cold applied wax tape or moisture cured wrap. The UV resistant coating should extends from approximately 12" below grade to approximately 12" above grade or near the bottom of an above grade valve, whichever comes first. The UV resistant coating should be applied using a continuous application method. Paint is not an approved UV resistant coating.

Corrosion Control wants the above grade wrap to be UV resistant in order for sun's rays not to damage the coating. Pointed out paint is not UV resistant.

1. F. (5): New, Moisture cured wrap can be applies as a protective overcoat over all other coatings when there is a need to provide protection from abrasive action or mechanical damage.

Moisture cured wrap provides a relatively hard surface that is not easily damaged by abrasive action.

7. Approved Paints Specifications

UNCONTROLLED IF PRINTED

7. C.: New, Added a temperature limitation for applying paint based on manufacturer's specifications.

Quality Assurance Consultants request this be added.

CORR 2.04	<p>General Wrapping Instructions</p> <p>3. Service Tee Hot Applied Tape</p> <p>3. A.: New: Addresses service tee or a small fitting being welded on a 12 inch or larger steel pipe where only a small amount of existing pipe coating, FBE or coal tar, is removed to make the weld. Hot wrap or liquid epoxy should be used to cover the bare steel. The hot wrap or liquid epoxy should extend at least 6 inches beyond the bare area and the edges of the hot wrap sealed tightly.</p> <p>Current procedures require the hot wrap to fully encircle the pipe. This is impractical when only a small area of existing coating is removed on a large diameter steel pipe.</p> <p>3. B.: New: When service tee or fitting is being installed on steel pipe smaller than 12 inches, the hot wrap is to be installed in accordance with the current procedures in CORR 2.04</p> <p>Notes added below 3. C. (4), For 12 inch and larger pipe, see 3. A. above for wrapping instructions.</p>	<p>Janu- ary 1, 2013</p>	<p>Janu- ary 1, 2018</p>
CORR 2.11	<p>Moisture Cured Wrap - New section inserted where 3M Scotchkote Hot Melt Patch Compound had previously resided.</p> <p>Procedure for the application of moisture cured wrap on girth welds and soil air interface zone.</p> <p>Corrosion Control provided these procedures following field trials.</p>	<p>Janu- ary 1, 2013</p>	<p>Janu- ary 1, 2018</p>
CORR 2.17	<p>AC Voltage</p> <p>2. AC Voltage at Customer Meter Set</p> <p>2. A. Testing for AC at Meter Set</p> <p>2. A. (1): The meter set should be checked in 3 locations with volt stick and if voltage is indicated contact the Gas Supervisor or his designee to initiate an investigation. Volt Stick, stock code 85 36 376 is recommended for checking voltage.</p> <p>2. A. (2): Action Table - New, table replaced verbiage. If volt stick alarms, Dispatcher is to be contacted to request an Electric Service person come measure the voltage. If it is in a non-Ameren IL electric service area, Dispatcher should contact the appropriate electric provider.</p> <p>If voltage is less than 15 volts there is no action required since it is not a hazardous condition.</p>	<p>Octo- ber 1, 2011</p>	<p>Janu- ary 1, 2018</p>

If voltage is 15 volts or greater, Electric Department will investigate and take appropriate action. If the voltage is on the gas riser and Electric cannot determine the source, Corrosion Tech will investigate.

Completely revised this section to provide more guidance on how AC voltage on a meter set should be handled. Volt stick 85 36 376 is recommended because it is a non-adjustable and will alarm if voltage is over 12 volts. The red volt stick has a sensitivity adjustment which can change its alarm voltage.

**CORR
2.30**

Buried Pipe Examination

2. Buried Pipe Examination

2. A.: Clarification that Pipe Exam is to be completed when a gas carrying plastic or steel pipe is exposed by an excavation.

It is important to check the condition of existing pipe anytime it is temporarily uncovered. Atmosphere corrosion inspection is performed on pipe exposed by nature, i.e, erosion or flooding

2. E. A Buried Pipe Examination should not be performed when:

2. E. (2): Added, exposed pipe should be reported to Gas Supervisor for follow-up inspection when an exposed pipe is found during a pipeline or critical area patrol.

This to ensure an exposed pipe is contained in a critical area patrol or is being scheduled to be relocated or covered. Exposed pipe is examined for atmospheric corrosion.

2. E. (3): Reminders were added:

2. E. (3) (a): Pipe Examination should not be performed on retired pipe, retired sections of pipe or facilities.

2. E. (3) (b): Do not enter pipe to soil readings on Pie Examination for pipe classified as Unprotected Main, on rectified protected pipe when rectifier is turned off, if the pipe coating has not been disturbed or when an active replacement protect will retire the existing section of pipe within the next 12 months.

2. E. (3) (c): Do not take P/S until newly installed anode has been activated.

Corrosion Control added these reminders in an effort to reduce unnecessary work orders generated by Maximo for insufficient readings.

2. F. Common instances when Pipe Examination is required.

2. F. (1)-(4): Clarification that Pipe Exam should be completed for exposed pipe that will remain in service following the completion of the DOJM/WO project for Replacement, Relocation and Installation of service or main.

De-
cem-
ber 1,
2014

Janu-
ary 1,
2018

Clarification on when Pipe Exam is required.

3. Distribution

3. A.: Added reference to CORR 2.02 1. G. if the Pipe Exam is being completed following installation of an anode and P/S is still deficient.

Corrosion Control wants to reduce the number of unnecessary work orders generated by Maximo.

CORR 3.14	<p>Test Lead Wire Attachment</p> <p>1. General</p> <p>1. B.: Added Pin Brazing as another acceptable way to attach test lead to steel pipe.</p> <p>Pin brazing is a new approved process that is being used by contractor. Ameren IL gas personnel are not tooled up or trained for this process.</p> <p>1. C.: Welded steel bolt can now be used to connect test leads on distribution mains operating at or below 100 psig.</p> <p>Previously, a steel bolt could be welded on pipe operating at or below 60 psig.</p> <p>5. Pin Brazing - New section approved and added by Corrosion Control and Gas Standards to be utilized by contractor.</p> <p>6. Welded Bolt Anode Wire or Test Lead Connection to Steel Pipe</p> <p>6. A.: Welded steel bolt can now be used to connect test leads on distribution mains operating at or below 100 psig.</p> <p>After consultation with a welding consultant, Operation's request to allow welded bolt connections on pipe operating at 100 psig was approved.</p> <p>7. Test Lead Attachment Coating</p> <p>7. B.: Viscotaq Coating Patch - New product Approved by Corrosion Control and Gas Standards as an eventually replacement for Handy Cap.</p>	<p>Janu- ary 1, 2016</p>	<p>Janu- ary 1, 2018</p>
CORR 3.16	<p>AC Stray Current Test Station</p> <p>Updated to provide more detail instructions on where all of the test wire connection should be made. Test station configuration clearly identifies connections.</p> <p>Corrosion Control provided test station connection details</p>	<p>Janu- ary 1, 2013</p>	<p>Janu- ary 1, 2018</p>
EMER 2.02	<p>Dispatch Center</p> <p>1. General</p>	<p>Janu- ary 1, 2016</p>	<p>Janu- ary 1, 2018</p>

1. G.: Updated, Distribution Control has compiled and maintains the 911 numbers for emergency agencies through-out Ameren Illinois operating areas.

Eliminates the need for the Divisions to provide emergency numbers to Distribution Control.

**EMER
2.04**

Gas Field Personnel

Janu- Janu-
ary 1, ary 1,
2016 2018

1. General

1. B.: New, added the contact information for individuals in Gas Operations & Services, Gas Control and Distribution Control is in the Forward section.

Throughout the O&M there are references to contacting other Gas Operations & Services groups. Compliance felt contact information would be beneficial.

2. Inside Odor Compliant - Hazardous Condition

2. I.: New, Check for presence of a stand-by generator and if possible shut-off at generator's outside disconnect switch.

The stand-by generator could be a potential source of ignition if it attempts to start when the electric service is disconnected.

2. J.: Revised the disconnecting of electrical service. The electric source has to be disconnected at the power pole or transformer.

Having AMI meter shut-off remotely does not satisfy disconnecting from and external source. The switching action in the AMI meter could generate a spark.

If possible cut the telephone at a point away from the structure. If not possible, the phone line can be cut-off at the junction box on the structure as long as the junction box has been checked for possible concentration of gas.

Clarification of where telephone service can be disconnected.

3. Outside Odor Complaint - Hazardous Condition

3. F.: If leak was caused by excavation damage, investigate for the possibility of multiple leaks and migration into adjacent structures.

Emphasis on the importance of performing an investigation to ensure there are no other leaks created when an excavator has damaged our facilities.

3. G.: New, If leak could have been caused by any boring operation, immediate and continual investigation for potential gas migration into conduits, sewer lines, or structures is required.

Emphasis on the importance of performing an investigation to determine the extent of gas migration when boring operations have damaged our facilities.

3. J.: If steel pipe is squeezed to shut-off gas flow, the squeezed section of pipe has to be cut out and replaced before the pipeline is reinstated.

To avoid flow restriction and possibility of pipe failure, a squeezed section of steel pipe should not be re-activated until the squeezed section is removed and replaced.

4. Major Leaks or Line Breaks

4. A.: Added a new requirement, If leak the damage was caused by any boring operation, immediate and continual investigation for potential gas migration into conduits, sewer lines, or structures is required.

Emphasis on the importance of performing an investigation to determine the extent of gas migration when boring operations have damaged our facilities.

EMER 2.06

Emergency Personnel and Materials

April 1, 2013 January 1, 2018

2. Emergency Gas Materials

2. A.: Gas Standards Engineer will determine what emergency material will be stored in each of the designated central storeroom locations

2. B. (1): Changed the size of emergency steel pipe, 2" through 30", that will be stored at the MDF and a separate location.

3. Centralized Emergency Gas Material

3. B. (2): Stipulated that the emergency pipe will be pretested in accordance with PTST 1.

3. B. (3): Gas Tech Engineering will provide test pressure required for the emergency pipe.

3. C. (1): Storeroom personnel will arrange picking, loading and shipping of items after a request for emergency material has been made.

3. C. (2): Emergency material will be replaced with like size and kind through the automated process in EMPRV.

3. C. (4): Gas Standards Engineer will inventory emergency material at the Centralized locations on a biannual basis.

4. Non-Centralized Emergency Gas Material

4. A. Plastic Materials

4. A. (1): Emergency PE pipe will be pretested in accordance with PTST 1.

4. A. (4): Shelf life of PE pipe has been increased to 3 years from 2 years. Pipe stored for emergencies should be inspected to make sure the pipe does not exceed the shelf life.

4. B. Steel Pipe and Fittings (4" and less in diameter)

4. B. (1): Areas other than designated centralized locations should keep 100' or less of 3/4" through 4" pretested steel pipe for emergency situations.

Emergency materials sections were revised following discussions with Operations and Gas Tech Engineering on what designated material should be stored at centralized locations. Ameren Illinois now has a designated Gas Standards Engineer who will ensure the centralized locations are maintaining their emergency material inventory.

EXCV
2.03

Work in Excavation

January 1, 2014 January 1, 2018

3. Working in Excavation

3. K.: Added, Prior to leaving the jobsite, any open excavation should be secured to prevent unauthorized access, i.e. temporary fencing.

From a safety perspective, open excavations need to be delineated and secured to protect the general public from injury obtained by falling into an excavation.

EXCV
2.04

Soil Analysis and Classification

January 1, 2016 January 1, 2018

6. Excavation/Soils Checklist

6. B.: Revised, The Competent Person is required to evaluate and classify the soil prior to personnel entering the excavation.

Removed the confusing statement that requiring a completed Checklist prior to personnel entering the excavation. Personnel are required to be in the excavation probing for buried utilities during the excavation process and before all of the soils can be classified.

6. E. Removed the sample of the Excavation/Soils Checklist.

Ameren Illinois Safety maintains an electronic copy on their SharePoint Site. As the Safety Department makes changes to this Checklist the most current version will be available on the SharePoint Site.

FORW

Forward

September 1, 2016 January 1, 2018

Added and updated information on contact individuals within the various Gas Operations & Services departments or groups.

Throughout the O&M there are references to contacting other Gas Operations & Services groups. Compliance felt contact information should be provided.

GLOS

Glossary

April 1, 2017 January 1, 2018

Updated:

LEL - Changed to 5.0% gas-in-air from 4.5%

UEL - Changed to 15.0% gas-in-air from 14.5%

In the O&M 30% LEL is equated to 1.5% gas-in-air and 60% LEL is equated to 3.0% gas-in-air. In order for this to be correct the LEL needs to be 5.0% gas-in-air. The industry recognized explosive limits of natural gas is 5.0 to 15.0% gas-in-air.

INCD
1

Requirements

April 1, 2017 January 1, 2018

5. Service Interruption/Curtailment Notification

5. B. Service interruption of more than 25 customers for 8 hours or more

5. B. (1): Added contact information for ICC's Consumer Service Division and Director, Safety and Reliability Division.

6. Reporting

6. D.: New, Within 48 hours after confirmed discovery of a natural gas incident a second notification is required to revise or confirm the initial telephonic notice.

PHMSA requires a second notification

INVE
2.01

Incident Investigation

January 1, 2016 January 1, 2018

2. Investigation Documentation

2. J.: Added Only one person should be designated to take photos.

Ameren Claims wanted this emphasized because photos are evidence and we only want one set of photos. This is consistent with policy that one person should be designated to document the incident investigation. Also all cameras or cell phones that are used to take photos would be collected as evidence.

3. Investigation of Ameren Illinois Facilities

3. E.: Updated to request remote automated meter readings (AMI/AMR) as soon as practical.

Request must be made as soon as possible to ensure the readings are obtained before they are no longer available.

3. K. Documentation of transfer of custody of evidence should be done on Chain of Custody Log. See INVE 4

Clarified the Chain of Custody Log is used to document transferring evidence to another party.

LEAK
2.01

Indoor Leak Investigation

January 1, 2016 January 1, 2018

4. Customer is Home

4. G.: When there is inaccessible piping or appliance(s) that cannot be checked with leak detection instrument or leak de-

tection fluid, a minimum 5 minute shut in test shall be performed.

If piping or appliances cannot be checked for leaks, a shut in test is the only alternative.

LEAK 2.02	<p>Outdoor Leak Investigation</p> <p>5. Below Grade Gas Facilities</p> <p>5. F. New section was added to provide additional steps that should be taken when gas is detected in a sewer line. Until an ethane identifier has been used to verify the source, the investigation shall assume the source to be natural gas. If the concentration is 30% LEL of greater initiate EMER 2.04 5. Gas In a Sewer. If the concentration is less than 30% LEL expand the investigation.</p> <p>Gas Compliance felt there needed to be more guidance when our gas detection instruments detect a concentration in a sewer line.</p>	<p>Janu- ary 1, 2016</p>	<p>Janu- ary 1, 2018</p>
LEAK 2.04	<p>Leak Classification and Surveillance</p> <p>4. C.: Added reference to LEAK 2.09 1. N. (5) Walking Leak Surveys for procedures on measuring gas in a valve box.</p> <p>Measuring volume of gas in a valve box is different than in a tunnel or sewer lines manholes. In a valve box, the lid is to remain on while measuring gas concentration.</p>	<p>De- cem- ber 1, 2014</p>	<p>Janu- ary 1, 2018</p>
<u>MAIN</u> 1	<p>Requirements</p> <p>3. Cover</p> <p>3. F.: New - Added a general rule that mains should not be installed at a depth greater than 48 inches.</p> <p>SMR Team wanted to add this as a reminder to avoid additional shoring requirements whenever possible.</p> <p>19. Back-Flagging</p> <p>19. A,: Revised, Newly constructed Ameren Illinois gas facilities shall be back-flagged as stated in DAMG 1 3. D. which requires all newly installed facilities to be back-flagged.</p> <p>DAMG 1 3. D. requires newly installed facilities to be back-flagged. Damage Prevention groups have determined that back-flagging is one of the best practice to minimize 3rd party damage to newly installed facilities.</p>	<p>Janu- ary 1, 2016</p>	<p>Janu- ary 1, 2018</p>
MAIN 2.05	<p>Pipe Coating and Gasket Removal</p> <p>Section has been totally revised to provide more detailed procedures for removing coal tar pipe wrap and gaskets which may contain asbestos.</p>	<p>Janu- ary 1, 2011</p>	<p>Janu- ary 1, 2018</p>

MAIN 2.05 was used as basis for the Pipe Wrap and Gasket Removal training conducted in 2017.

METR 2.15	<p>Elevated Metering Pressure</p> <p>6. Records</p> <p>6. B.: New, The Gas Meter Data Sheet is to be distributed to the appropriate individuals/department as shown on the GMDS.</p> <p>6. C.: New, Gas Meter Data Sheets that are completed on the paper form should be transferred to the electronic form for distribution. See METR 4 for the Gas Meter Data Sheet form</p> <p>Provides information on how Gas Meter Data Sheets are to be distributed.</p>	<p>Janu- ary 1, 2017</p>	<p>Janu- ary 1, 2018</p>
METR 2.19	<p>Pressure Factor Verification</p> <p>3. Pressure Factor Verification</p> <p>3. D. The employee completing the pressure check shall record the following:</p> <p>3. D. (7): Discrepancies that require follow-up action are to be noted in the Comments.</p> <p>Comments are needed to better identify the discrepancies then the current (Y/N). Corrosion items have been moved to the Corrosion Control Inspection section.</p> <p>4. Verification Requirements Concerning Billing Constants and Pressure</p> <p>4. A.: Reduced the pressure variance to $\pm 1\frac{1}{4}$ psig from $\pm 1\frac{1}{2}$ psig. Gas Supervisor is to be notified if the physical check of the meter pressure differs from the listed metering pressure by more than $\pm 1\frac{1}{4}$ psig.</p> <p>5. Pressure Factor Verification with Recording Charts.</p> <p>5. D.: Reduced the pressure variance to $\pm 1\frac{1}{4}$ psig from $\pm 1\frac{1}{2}$ psig. Recording charts should be used if is suspected the regulator cannot maintain the metering pressure within $\pm 1\frac{1}{4}$ psig.</p> <p>In January 1, 2017 O&M Update reflecting implementation of IAC 501, the change to $1\frac{1}{4}$ psig was made in METR 2.15 but was missed in this section. IAC 501 requires a bill adjustment if the measured metering pressure differs from listed by $\pm 2\%$, a reduction from the previous $\pm 4\%$.</p> <p>7. Corrosion Control Inspections</p> <p>7. A.: Revised, Gas metering facilities shall have the below corrosion control inspection activities completed.</p> <p>(1) Atmospheric corrosion shall be documented within Click-Mobile per CORR 2.31</p>	<p>Janu- ary 1, 2017</p>	<p>Janu- ary 1, 2018</p>

(2) Disbonded coating and needs paint shall be documented within ClickMobile if follow-up is required.

Clarification on how corrosion issues are to be documented.

METR 3.01	<p>New Meter Sizing</p> <p>3. Approved Meters for New Installations</p> <p>The American AL 425 10 lb. regulator is no longer approved for 10 psig Metering Pressure.</p> <p>Current regulator options will not prevent the pressure from exceeding the meter's MEP of 15 psig.</p> <p>3. Approved Meters for New Installations</p> <p>3. Notes: Added Romet of comparable sizes.</p>	Janu- ary 1, 2016	Janu- ary 1, 2018
METR 3.03	<p>Regulator Sizing - 7" W.C. Delivery Pressure</p> <p>Updated the Notes and Capacities</p>	Sep- tember 1, 2016	Janu- ary 1, 2018
METR 3.04	<p>Regulator Sizing - 2 PSIG Delivery Pressure</p> <p>Updated the Notes and Capacities</p>	Sep- tember 1, 2016	Janu- ary 1, 2018
METR 3.09	<p>Metering Standards - Diaphragm Meters</p> <p>Added the 1" x 1" Itron B42R and American 1813C</p>	Janu- ary 1, 2013	Janu- ary 1, 2018
METR 3.11	<p>Regulators and material for 1" Meter Set</p>		
METR 3.12			
METR 3.13			
METR 3.15	<p>Metering Standards - Diaphragm Meter</p> <p>Added the 1" x 1" Itron B42R and American 1813C</p> <p>Regulators and material for 1" Meter Set</p>	April 1, 2013	Janu- ary1, 2018
METR 3.14	<p>425 Meter, By-Pass, 2 & 5 PSIG Delivery Pressure, 5-60 PSIG Inlet.</p> <p>No Longer Approved for 10 psig delivery pressure because current regulator options will not protect meter from exceeding its MEP.</p> <p>Under Installation, removed 16 psig MEP for 10 psig delivery.</p> <p>MEP is 15 psig and current regulator options will not meet this requirement.</p>	Janu- ary 1, 2014	Janu- ary 1, 2018

METR 3.19	Metering Standards - Rotary Meters Updated to the Fisher CS806 - IQ and CS826-IQ Regulators and Updated the Meter Set Drawings	April 1, 2013	Janu- ary 1, 2018
METR 3.20			
METR 3.21			
METR 3.24			
METR 3.25			
METR 3.22	Metering Standards - Rotary Meter Updated to the Fisher CS826-IQ Regulators and Updated the Meter Set Drawing	Janu- ary 1, 2013	Janu- ary 1, 2018
OQAL 1	Requirements 5. Abnormal Operating Conditions This section has been revised and lists AOCS's that are contained in Appendix E of ASME B31Q Ameren Illinois Operator Qualification program follows ASME B31Q. 7. Disqualification This is a new section which describes the steps to be taken when an employee is disqualified for a covered task. OQ section has developed a specific course of action when an employee has be disqualified from performance of a covered task.	Janu- ary 1, 2016	Janu- ary 1, 2018
POLY 2.04	Butt Fusion 1. General 1. C.: Clarification, Butt fusion joint is not allowed when joining two sections of pipe if one of the sections is Aldyl A. MDPE and HDPE pipe can be butt fused together. The melt time is different for the Yellow PE pipe than for the Aldyl due to the difference in resin used in manufacturing the pipe. Since the MDPE and HDPE are made of the same material they can be butt fused together. The bead melt may be a little different. 4. Joint Assembly 4. H.: Added a Caution, Alcohol or other solvents are not to be used to clean the pipe wall after facing. Caution was added to conform to Performance Pipe's instructions.	July 1, 2012	Janu- ary 1, 2018

4. J.: Added heating faces shall be cleaned prior to inserting the heating faces. Do Not use synthetic material to clean heater faces.

Added to conform to Performance Pipe's instructions.

4. Q. Table: Updated the melt bead size based on Performance Pipe's information.

5. Hydraulic Machine Fusion - New

Follow the operating instructions contained in the hydraulic butt fusion machine manufacturer's instructions.

Previous O&M did not include any language about hydraulic butt fusion. Since there are different hydraulic machine being used, it is simpler to state follow the manufacturer's instructions.

**POLY
2.05**

Electrofusion

January 1,
2016

January 1,
2018

Procedures have been modified by eliminating the requirement for using the fitting to mark the area to be scraped. The area can be marked by using a measurement which could be with a ruler, tape, gauge or the fitting. The majority of the pictures have also been removed.

1. General

1. D.: Added, Electrofusion fittings can be re-fused only in the event of an input power interruption.

Central Plastic's requirement

1. H.: Added, PE pipe 2 inch and larger in diameter no more than 2 passes with the scraper are allowed. PE pipe smaller than 2 inch only 1 pass with the scraper is allowed.

Prevents the removal of too much wall thickness. Based on information from Central Plastic.

1. I. Table: Revised the maximum allowable gap from square for Central Plastic fittings and for Innogaz/Friatec.

Based on information from Central Plastic and Plastic Pipe Institute.

2. Equipment, Weather and Cleanliness Guidelines

2. D.: Updated inverter requirements to a minimum of 3000 watts output from over 3000 watts.

New gas construction vehicles are coming with 3000 watt inverters

3. Electrofusion Couplings and Caps - Added caps

Eliminated the separate section on caps since their installation process is basically the same as a coupling. Cap has been added to coupling throughout this section.

3. A. Preparation Prior to Scraping

3. A. (6): Revised to allow the area to be scraped to be marked based on a measurement instead of using the bagged fitting. Does require the scraped are to be a minimum of half the length of the coupling/cap or full length whichever is applicable.

Base on field input it was agreed that measuring the area to be scraped was acceptable and in reviewing Central Plastics procedures they refer to measure and mark even though their picture shows using a coupling to mark the area.

3. B. Scraping

3. B. (1): Revised, for 1-1/4" and 2" IPS pipe may require the use of an insert stiffener.

Added a Note that SDR 7.0 and SDR 11.0 pipe will require a different scraper.

Eliminated requiring the use of an insert stiffener, Stiffener only necessary if the pipe is out of round or needs straighten to get a uniform scrape.

4. Electrofusion Service Tees, High Volume Tees or Repair Saddles - Added Repair Saddles

Throughout this section Repair Saddles has been added where ever tee is mentioned.

4. A. Preparation Prior to Scraping

4. A. (2) Added Repair saddle can be used to repair some imperfections as shown in REPR 1. 5. D.

4. D Tapping

Added If service tee is being tested with the main, the tee will be tapped before pressure testing.

4. D. (6): Added, service tees pressure tested with the main are exempted from this requirement since a successful leak test will document no leakage.

Addresses service tees being leak tested with the main. Which is covered in PTST 1.

6. Electrofusion Elbows

6. B. Scraping

6. B. (1): Revised, for 1-1/4" and 2" IPS pipe may require the use of an insert stiffener.

Eliminated requiring the use of an insert stiffener, Stiffener only necessary if the pipe is out of round or needs straighten to get a uniform scrape.

**POLY
2.06**

Mechanical Joining
2. Stab Fittings

July 1,
2012 Janu-
ary 1,
2018

UNCONTROLLED IF PRINTED

2. F.: Added, stab caps can be used to cap end of 1/2" through 1" service line and to cap the purge cap pigtail during the testing and upon completion of the test.

Allows the use of a stab cap to cap the pigtail on the PE purge cap upon completion of the pressure test.

POLY 2.09	<p>Plastic Fusion Qualifications</p> <p>2. Fusion Qualification</p> <p>2. C.: Reduced the fusion methods required for annual qualifications to:</p> <p>Butt Fusion - Manual</p> <p>Butt Fusion - Hydraulic</p> <p>Electrofusion - Coupling and Service Tee</p> <p>Code requires qualifications on the processes not the material so separate tests on the MDPE and HDPE pipe is not required.</p>	<p>Janu- ary 1, 2016</p>	<p>Janu- ary 1, 2018</p>
PTST 1	<p>Requirements</p> <p>5. Testing</p> <p>5. E. was added to address testing mains and services together.</p> <p>5. E. Revised, In order to assist in locating a leak resulting from a pressure test, main and service line(s) should be tested separately. For short main extension, repair, or emergency project(s), the Gas Supervisor or Project Engineer may approve testing main and service(s) together.</p> <p>(1) For service line(s) less than 2 inch in diameter, the minimum required test duration for the combination main and service(s) will be determined by the required test duration of the main as shown in PTST 2.01 3 Leak Test Duration. There is no need to add time for the service lines.</p> <p>(2) Service line(s) 2 inch and larger shall be tested as main with the minimum duration determined in accordance with PTST 2.01 3. C. or if applicable PTST 2.01 3. C. leak test duration when testing main of various size pipe</p> <p>(3) Service line(s) pressure test shall be recorded on the Service Card within ClickMobile with the actual test pressure and actual test duration reported for each service.</p> <p>Testing main and service is discouraged but knowing that it is happening these procedures were added to ensure the proper testing is being performed.</p>	<p>April 1, 2017</p>	<p>Janu- ary 1, 2018</p>
PTST 2.01	<p>Leak Test</p> <p>1 General</p>	<p>Sep- tember 1, 2017</p>	<p>Janu- ary 1, 2018</p>

1. G.: Revised to match language in PTST 1 5. A. above concerning testing main and services together,

**PURG
2.01**

Purging Methods

January 1, 2017
January 1, 2018

1. General

1. B.: Gas Engineering or GTE will provide a detailed purge plan prior to blow down or purging operations on transmission mains or high pressure distribution mains or service lines 2 inch and larger; that are (A) 100 feet or longer and (B) operating at more than 100 psig

Revised to eliminate the need for engineering to provide detailed plans when short sections, less than 100 feet, are being purged.

4. Purging of Air with Gas

4. C.: Revised, purge is complete when CGI reading reaches 90% Gas-in-air or greater. Changed from 95% - 100% Gas

5. Purging of Gas with Air

5. C.: Revised, purge gas from the pipeline until a combustible mixture is no longer present, 2% LEL or less. Changed from 0%

6. Using an Inert Gas Slug when Purging

6. A.: Purging mains 8 inches and larger, 100 feet or longer that operating at more than 100 psig, a slug of inert gas should be inserted between the air and gas.

A slug of inert gas does not have to be used to separate the air and gas when purging short sections of pipe.

6. E.: Removed the language regarding when a purge is complete since it discussed in earlier sections.

8. Vacuum Purge/Air Mover

8. J.: Revised, purge gas from the pipeline until a combustible mixture is no longer present, 2% LEL or less.

Percentages were revised to reflect the sensitivity of our electronic instruments and discussions with manufacturer's representative.

**REGS
3.01**

Regulator Station Design

October 1, 2011
January 1, 2018

3. Standardized Design Features

3. O.: Revised, the top of the relief stack should be a minimum of 6 feet above ground level.

Gas Tech Engineering (GTE) reduced the 7 feet minimum and removed the maximum of 8 feet above the ground level.

3. Q.: New, At differential pressures greater than 300 psig, consideration should be given to installing multiple regulator cuts per run.

3. R: New, For additional protection on boot style monitor regulator stations, the outlet token relief valve should be a 1" 289P or 1" 289H (set points less than 10 psig) to provide additional failure protection in the event of liquid build up on the flexible boot element.

Design update provided by Gas Tech Engineering.

4. Standardized Regulator Station Drawings

4. B.: Corrected link to Regulator Station drawings, Organizational Data drive "O"\GAS\Regulator Station Design Standards.

4. C. Tables: Revised the Regulator Station Design Matrix

GTE has revised the design standards for Regulator Stations.

**REGS
4**

Forms and Reference Materials

January 1,
2013

January 1,
2018

Updated all of the Standardized Regulator Designs pdf drawings

GTE has revised the design standards for Regulator Stations.

**REPR
1**

Repairs

December 1,
2014

January 1,
2018

1. Objective

1. F.: Clarification, Gas Tech Engineering should be notified before performing repairs on facilities with MAOP greater than 100 psig.

Due to the emphasis on system integrity, it is important that Gas Tech Engineering be involved in work performed on high pressure distribution and transmission facilities. However, it was felt that the Divisions should be able to properly handle repairs on facilities with MAOP 100 psig or less.

1. J.: Clarification, Make Safe repair provisions and the 90 days to complete permanent repairs does not apply to leaking compression couplings within 5 feet of a foundation.

Needs to be consistent with REPR 2.01 Compression Couplings. Leaking compression couplings within 5 feet of a foundation must be permanently repair at time of discovery.

3. High Pressure Distribution and Transmission Pipe Repair - Pipe replaced Line

Incorporated former REPR 6. Into this section and updated position titles to Pipeline Integrity, Gas Tech Engineering and Division Gas Engineer throughout this section.

3. F.: Added that encapsulation of a leaking fitting is also an approved repair method.

There was not sufficient room in the table to added encapsulation.

3. F. Table: Updated some of the defect descriptions and the Notes below the table. Weld deposition is now only approved for repair of non-leaking weld defect or a leaking weld defect if the line is taken out of service.

Notes were updated to comply with Part 192.309 and 192.711, 192.715 and 192.217. Stainless steel clamps can be used for a Make Safe repair as long as the clamp is rated for the operating pressure or the pressure is reduced to the clamp's pressure rating.

3. G. thru 3. N. are the approved repair procedures for high pressure distribution and transmission pipe.

3. K. Weld Deposition

3. K. (2): For transmission line, pressure must be below 20% SMYS to qualify as a safe level.

Part 192.715

3. L.: Plidco Split + Sleeve

3. L. (3): Permanent repair requires seal welding if the MAOP is 20% SMYS or greater.

3. L. (4): Permanent repair does not require seal welding for pipe with MAOP less than 20% SMYS.

Part 192 requires seal welding for permanent repairs on transmission pipe but not on distribution pipe.

4. Steel Distribution Pipe Repair

4. C.: Plidco Split + Sleeve does not have to be seal welded to be a permanent repair

4. E. Approved Repair Methods

4. E. (1): Added, that in addition to the methods shown in the table, tapered screw plug can be used on small non-corrosion leaks and encapsulation can be used on leaking fittings.

4. E. Table: Separated non-leaking and leaking weld defect. Updated Note on Plidco Split + Sleeve not requiring seal weld to be a permanent repair.

4. F. thru 4. N. are the approved repair procedures for steel distribution pipe.

4. F. (3): If PE pipe is being installed within an existing steel system, contact corrosion control personnel for cathodic protection requirements

Concern that an existing cathodic protected segment could be separated leaving an isolated unprotected section. ICC does not consider bonding a tracer wire to two segments of steel pipe as being continuously protected.

4. J. (2): Plidco Split + Sleeve is approved for permanent repair without being sealed welded.

5. PE Pipe Repair

5. A. General

5. A. (4): Added, Stainless steel bolted leak clamps are not designed for PE pipe and are not to be used for leak repairs.

Clamp manufacturer says these clamps are not designed for PE pipe.

5. B. Approved PE Repair Methods

Added EF Repair Saddles and Electrofusion Coupling.

5. D. Electrofusion Repair Saddles

5. D. (1) thru (5) are the requirements

5. F. Electrofusion Coupling

5. F. (1) & (2) are the requirements.

EF Repair Saddles are available in 4" and 6" and can be used for repairing pipe defects of 10% or less of the wall thickness. EF couplings can be used to repair cut PE pipe.

7. Repair Records

7. A. Pressure Test

7. A. (1) thru (4) Section was expanded to address test records for pipe and components installed for repairs. The test pressure and duration will continue to be reported in the Leak Repair form within ClickMobile. In addition, test record and pipe information will need to be recorded on the appropriate Leak Test Form (LTF) or Leak Strength Test Form (LSTF) and a copy of that record kept with DOJM/WO job packet.

7. A. (5) Tie-in connections are to be leak tested at normal operating pressure and recorded as: Repair Successfully Leak Tested on the Repair Form in ClickMobile or Tie-in Joints Tested on the appropriate Leak Test Form (LTF) or Leak & Strength Test Form (LSTF)

7. B.: The repair records should include the date, location, and description of each repair

7. B. (2): Records pertaining to non-leak repair shall be maintained in the job packet for the life of the facility.

This information is needed to document the integrity and the MAOP of the gas system.

**SERV
1**

Requirements

12 Back-Flagging

12. A.: Revised, Newly constructed Ameren Illinois gas facilities shall be back-flagged as stated in DAMG 1 3. D.

DAMG 1 3. D. requires newly installed facilities to be back-flagged. Damage Prevention groups have determined that

April 1, 2017 January 1, 2018

back-flagging is one of the best practice to minimize 3rd party damage to newly installed facilities.

SERV 2.08	<p>Insertion</p> <p>4. Dead Insertions</p> <p>4. S. (2): New, Stock Code listing for indoor service head adapters.</p> <p>A specially designed service head adapter is required when inserting a PE service line thru a foundation wall.</p>	April 1, 2017	Janu- ary 1, 2018
SERV 3.05	<p>2" PE Service Line</p> <p>10.: New, Notice added which states the manufacturer of the 2 inch anodeless riser says the threaded end of the riser cannot be removed to allow for welding.</p> <p>Manufacturer states there is insufficient space between the transition area and the weld to avoid damage to the inserted PE pipe.</p>	April 1, 2013	Janu- ary 1, 2018
STLP 1	<p>Requirements</p> <p>12. Pipe Thread Sealers</p> <p>12. C. Approved Pipe Thread Sealers</p> <p>Added Hercules Real Tuff, Hercules Megaloc and LA-CO Slic-Tite.</p> <p>Removed J.C. Whitlam Blue Magic</p> <p>Gas Standards Committee evaluated and approved the 3 additional thread sealers. Due to issues with reported leaks the Committee has removed Blue Magic as an approved sealer.</p>	Janu- ary 1, 2016	Janu- ary 1, 2018
STLP 2.01	<p>Design Pressure</p> <p>8. Dual Coated Steel Pipe</p> <p>8. B.: Correction made, a dry film coating thickness detector is to be used to measure coating thickness not an ultrasonic thickness gauge.</p> <p>Gas Tech Engineer pointed out an ultrasonic thickness gauge will only measure wall thickness not coating thickness.</p>	Janu- ary 1, 2016	Janu- ary 1, 2018
STLP 3.04	<p>Flanges</p> <p>2. Flange Assembly</p> <p>2. C.: New section added to address the proper size and length of stud bolts for the various pressure classes of flanges with a reference to the Flange Stud Bolt section of STLP 3.04.</p> <p>2. D.: New section added which states, The bolt or stud bolt shall extend completely through the nuts.</p>	Janu- ary 1, 2011	Janu- ary 1, 2018

The ICC requested language be added to provide more guidance and instructions on the proper installation of flange bolts.

TAPS 2.06	<p>TDW PE Branch Saddle-Valve</p> <p><u>3. PE Branch Saddle-Valve</u></p> <p>Added stock codes for the saddle-valves that are now available through MDF.</p> <p>No longer have to order the saddle-valve through the training center.</p>	Janu- ary 1, 2011	Janu- ary 1, 2018
UPRT 1	<p>Requirements</p> <p>2. Increasing MAOP Up to 100 PSIG</p> <p>2. K.: Clarification, Leak survey should be performed immediately after each pressure increase and should continue until the affected area has been surveyed.</p> <p>The SMR Team wanted to clarify that the leak survey should be performed immediately after the pressure increase to ensure there were no hazardous leaks.</p>	Octo- ber 1, 2011	Janu- ary 1, 2018
WELD 2.03	<p>Construction of Pipelines and Piping Systems</p> <p>8. Welding Requirements</p> <p>8. A. (1) (c): Removed "Preferred E8010 electrode is E8010-G or 70+.</p> <p>Electrodes are shown in the Welding Procedures (WPSs) in WELD 4.</p> <p>8. N. Weld Pass Requirements</p> <p>8. N. (3): New, Unfinished welds that have cooled should be heated to between 200° F and 500° F prior to completion</p> <p>8. O. (1): Revised to clarify when preheating of welds is required. A minimum 200° F maximum 500° F preheat or inter-pass temperature is required when ambient temperature is below 50° F. Heating may be required to remove moisture from the welding region, a minimum 2 inches on each side around the joint prior to welding.</p> <p>Language from API 1104 recommended welding practice code and matches what is in the welding procedures (WPSs) in WELD 4..</p> <p>8. U. Pipe Coating Protection</p> <p>8. U. (1): Specified that pipe coating on pipe 8 inch and larger should be protected from weld spatter and mechanical abrasion during welding.</p>	Janu- ary 1, 2016	Janu- ary 1, 2018

8. U. (2): New, If weld spatter is observed on smaller than 8 inch pipe, the pipe coating should be covered for protection before proceeding.

**WELD
2.04**

In-Service Welding

Janu-
ary 1,
2016 Janu-
ary 1,
2018

3. Material Requirements

Added, Backing strips should be low carbon material, example 1010, 1020 carbon mild steel.

4. Acceptable Repair Methods

4. C. Full Encirclement Sleeves

4. C. (4): New, Full encirclement sleeves that require "In-Service" welding procedures should be fitted with a low carbon steel backing strip under the longitudinal seam that contacts the carrier pipe. This is prevent arcing or welding to the carrier pipe in the hoop stress direction. Steel banding (strapping) shall not be used for backing strips.

Manufacturers of full encirclement sleeves recommend the use of backing strips along the longitudinal seam.

6. Welding Procedures

6. C. In-Service Welding Electrode Requirements

6. C. (1): Checking for high flow in pre 1975 pipe 4 inch and larger operating at above 100 psig is required which would indicate rapid cooling of the base metal.

6. C. (2): Provides guidance on how to check for rapid cooling, The welding region of the pipe should be preheated to between 400 and 500 degrees F. If the area cools to below 200 degrees F within 4 minutes, this is an indication of high flow.

6. C. (3): Clarify that a Lo Hydrogen electrode is E7018 H4R.

6. C. (9): New, Welding full encirclement fittings (Style 110, 220 or Mueller full encirclement control fittings) should utilize backing strips when using In-Service welding procedures.

Provide more guidance for In-Service welding.

7. Arc Burns

7. A.: Arc burns on pipelines operating at or above 40% SMYS shall be cut-out as a cylinder or eliminated in accordance with WELD 2.10 Arc Burn Removal.

Part 192.309 required arc burns on pipe operating or above this pressure be removed or repaired.

**WELD
2.06**

Radiographic Testing

Janu-
ary 1,
2016 Janu-
ary 1,
2018

This section has been rewritten with the assistance of a non-destructive testing consultant to provide more in-depth procedures which will ensure radiographic testing is properly being performed by individuals who are properly certified, utilizing

the proper tools, equipment and procedures, and the tests are being properly analyzed.

WELD 2.07	<p>Magnetic Particle Testing</p> <p>This section has been rewritten with the assistance of a non-destructive testing consultant to provide more in-depth procedures which will ensure magnetic particle testing is properly being performed by individuals who are properly certified, utilizing the proper tools, equipment and procedures, and the tests are being properly analyzed.</p>	Janu- ary 1, 2012	Janu- ary 1, 2018
WELD 2.08	<p>Liquid Penetrant Testing</p> <p>This section has been rewritten with the assistance of a non-destructive testing consultant to provide more in-depth procedures which will ensure liquid penetrant testing is properly being performed by individuals who are properly certified and the tests are being properly analyzed.</p>	Janu- ary 1, 2012	Janu- ary 1, 2018
WW- BG 2.01	<p>Hazardous Atmosphere</p> <p><u>3. Safe Zone</u></p> <p>3. B. (1) (b): Correction; should have been less than 60%LEL not less than 30%LEL.</p> <p>Correction was need to be consistent throughout the document.</p> <p>4. Working in a Hazardous Atmosphere</p> <p>4. E. New: Evaluate the proposed work area for the ability to retrieve a co-worker in the event a rescue is necessary. If the co-worker cannot be effectively removed from the area with the use of the lifeline, worker(s) should not enter the area.</p> <p>This is a Safety issue. Before a worker enters a hazardous atmosphere, there must be means of being able to extract that worker from the area if the need arises.</p> <p>4. G. (6) (b): A minimum of 2 people per worker should be manning the lifeline</p> <p>4. G. (6) (f): There should be a designated back-up person in Level 2 PPE.</p> <p>These were both added for safety reasons to ensure there are sufficient people readily available to respond to an emergency situation.</p>	Janu- ary 1, 2016	Janu- ary 1, 2018

MINOR REVISIONS HAVE BEEN MADE TO THE FOLLOWING SECTIONS. REVISIONS ARE SHOWN IN RED TEXT IN THESE SECTIONS OF THE O&M. IF THERE IS NO RED TEXT THAT MEANS TEXT WAS REMOVED.

ABND 0	<p>Table of Contents</p> <p>ABND 2.01: Added Joint Abandonment of Mains and Services</p>	Janu- ary 1, 2014	Janu- ary 1, 2018
-------------------	--	-------------------------	-------------------------

Removing;

ABND 2.02 Joint Abandonment of Mains and Services

ABND 2.03 Abandonment of Transmission Facilities

ABND 2.04 Contaminants

ABND 2.07 Discontinued Service

ABND 4: Added Mueller Steel Abandonment Cap for H-17800
Curb Stop Tees instructions

ABND 1	Requirements 2. Planning 2. B. and 2. C.	De- cem- ber 1, 2014	Janu- ary 1, 2018
ABND 2.01	Abandonment of Gas Facilities <u>2. A. Mains - General:</u> 2. A. (2) 2. A. (7) 2. B. PE Mains: 2. B. (2). <u>2. D. Regulator Stations:</u> 2. D. (2) 2. D. (4) <u>3. Services</u> 3. A. (1) 3. A. (2) 3. A. (3) 3. A. (5) 3. A. (6) 3. A. (7) 3. A. (9) 3. A. (11) 3. A. (18) 3. A. (19) <u>3. B. PE Service from PE Main</u> 3. B. (2) 3. B. (4) <u>3. D. Steel Service Lines</u> 3. D. (7)	De- cem- ber 1, 2014	Janu- ary 1, 2018

7. Records

7. C. Removed Service Transaction Form/Card

ABND 2.02	Removed, information is in ABND 2.01	October 1, 2011	January 1, 2018
ABND 2.03	Removed, information is in ABND 2.01	January 1, 2014	January 1, 2018
ABND 2.04	Removed, information is in ABND 2.01	January 1, 2011	January 1, 2018
ABND 2.07	Removed, information is in ABND 2.01	January 1, 2011	January 1, 2018
ABND 4	Forms and Reference Materials Added Mueller Steel Abandonment Cap for H-17800 Curb StopTees	January 1, 2016	January 1, 2018
ACIG 1	Requirements <u>2. Sources of Ignition</u> 2. C. 2. D. 2. E. 2. F. 2. G.	January 1, 2014	January 1, 2018
ACIG 2.01	Work Area Protection <u>3. Welding and Other Hot Work</u> 3. A. 3. B. 3. E. (5) <u>4 Working with Plastic Pipe</u> 4. D. <u>5. Isolating Pipeline Segments on Planned Work to Minimize the Potential of Ignition</u> 5. C. (4)	January 1, 2014	January 1, 2018

BORE 1	Requirements <u>2. Boring Operations</u> 2. C.	Janu- ary 1, 2013	Janu- ary 1, 2018
BORE 2.01	Boring Location Criteria <u>2. Methods of Boring</u> 2. B. <u>3. Boring Site Evaluation</u> 3. E. 3. F. 3. G. 3. H.	Janu- ary 1, 2016	Janu- ary 1, 2018
<u>BORE 2.02</u>	Boring Operations <u>1. General</u> 1. A. 1. B. <u>2. Boring Safety</u> 2. A. (3) 2. B. (1) 2. B. (3) <u>3. Prior to Beginning Operations</u> 3. D. <u>4. Conventional Rod Boring Operations</u> 4. E. <u>5. Pneumatic Piercing Tool Operations</u> 5. E. 5. K. Removed items to be observed <u>6. Directional Drilling Operations</u> 6. H. 6. Q	Janu- ary 1, 2016	Janu- ary 1, 2018
<u>BORE 2.04</u>	Boring Across or Near Sewer Lines 1. General Removed former 1. E. There are a number of steps available to avoid damaging sewer lines while boring.	April 1, 2017	Janu- ary 1, 2018

CLAS 1	Requirements 3. Records	Janu- ary 1, 2014	Janu- ary 1, 2018
CLAS 2.01	Class Location Determination <u>1. General</u> 1. A. 1. B. 1. C.	Janu- ary 1, 2014	Janu- ary 1, 2018
CLAS 2.02	Annual Class Location and HCA Study <u>1. General</u> 1. A. 1. B. <u>2. Action Required for Review of a Class Location Change</u> 2. A. 2. B. 2. B. (1) 2. B. (2) 2. B. (2) (a) <u>3. Action Required for a HCA Change</u>	Janu- ary 1, 2014	Janu- ary 1, 2018
<u>CONS 0</u>	Table of Contents CONS 1: Combined Work Performed by Contractors with Work Performed by Ameren Illinois Crews. Deleted Major Replacement Projects, New Business Projects, Transmission and High Pressure Distribution Projects	July 1, 2014	Janu- ary 1, 2018
<u>CONS 1</u>	Requirements <u>2. Construction Records, Maps and Operating History</u> 2. C. Removed MTD, lap top or office based computers <u>3. Gas Construction Work Performed by Ameren Illinois Crews or Contract Crews</u> 3. C. 3. D. Former 4. Gas Construction Performed by Contractors was merged into section 3. <u>4. Construction Inspector</u> 4. A.	De- cem- ber 1, 2014	Janu- ary 1, 2018

7. Major Replacement Projects, 8. New Business Projects and 9. Transmission Project information was moved into section 5. Construction Inspector

CONS 2.01	<p>Construction Inspector Responsibilities</p> <p>2. Job Assignment</p> <p>2. E.</p> <p><u>6. Daily Routine and Check Points for Contractors</u></p> <p>6. C. Now all tapping jobs, removed large</p> <p><u>7. Records</u></p> <p>7. I.</p> <p>Deleted former 3. Inspect Construction Area, moved to 2. E.</p>	<p>Janu- ary 1, 2014</p>	<p>Janu- ary 1, 2018</p>
CORR 0	<p>Table of Contents</p> <p>CORR 2.11 Moisture Cured Wrap was added</p> <p>CORR 3.14 5. Pin Brazing</p>	<p>Sep- tember 1, 2016</p>	<p>Janu- ary 1, 2018</p>
CORR 1	<p>Requirements</p> <p><u>2. Cathodic Protection Measurements</u></p> <p>2. C. Removed reporting P/S more negative than -3.0 volts to Corrosion Tech. Maximo will sent message.</p> <p><u>3. Corrective Action</u></p> <p>3. A.</p> <p><u>6. External Corrosion</u></p> <p>6. B.</p> <p><u>10. Test Lead Connections</u></p> <p>10. A.</p> <p>10. B.</p> <p><u>11. Electric Isolation</u></p> <p>11 D.</p> <p><u>13. Atmospheric Corrosion</u></p> <p>13. D. (3):</p> <p><u>14. Pipeline Facilities That Need to Be Painted</u></p> <p>14. C.</p> <p>14. C. (3).</p>	<p>April 1, 2017</p>	<p>Janu- ary 1, 2018</p>
CORR 2.02	<p>Anode Requirements</p> <p><u>1. General</u></p>	<p>April 1, 2017</p>	<p>Janu- ary 1, 2018</p>

	1. H.		
CORR 2.03	Coatings <u>1. Approved Coatings</u> 1. B. (1) <u>2. Approved Hot Applied Tapes</u> Added stock code for Tapecoat 20 - 3 inch width <u>6. Moisture Cured Wrap</u> Added stock code for Polyethylene/Stretch Wrap	July 1, 2016	Janu- ary 1, 2018
CORR 2.05	Tapecoat 20 <u>3. Coverage</u> 3. A. Note	Janu- ary 1, 2013	Janu- ary 1, 2018
CORR 2.06	Densotherm Tape <u>3. Coverage</u> 3. A. Note	Janu- ary 1, 2011	Janu- ary 1, 2018
CORR 2.09	Protal 7200 <u>2. Application</u> 2. A. (9) Added Stock Code	Janu- ary 1, 2016	Janu- ary 1, 2018
CORR 2.10	Protal 7125 2. Application 2. A. (8) Added Stock Code	Janu- ary 1, 2016	Janu- ary 1, 2018
CORR 2.15	Coating Inspection <u>6. Coating Repairs</u> 6. B.	Janu- ary 1, 2014	Janu- ary 1, 2018
CORR 2.16	Measuring Cathodic Protection Potentials <u>3. Procedures for Measuring Cathodic Protection Potentials</u> 3. B. Digital Multimeter replaced Digital Potential Meter <u>4. Equipment</u> 4. B.	July 1, 2014	Janu- ary 1, 2018
CORR 2.17	AC Voltage 3. Remedial Action for Ameren Illinois Facilities	Octo- ber 1, 2011	Janu- ary 1, 2018

CORR 2.20	Cathodic Protection Testing <u>1. Close Interval Survey</u> 1. B.: Removed Digital Potential Meter (DPM) 1. C. (3)	April 1, 2012	Janu- ary 1, 2018
CORR 2.25	AC Interference on Buried Pipelines <u>1. General</u> 1. A. <u>2. Types of AC Interference</u> 2. A. <u>3. Investigation AC Voltage on Pipelines</u> 3. B. (3) Caution: Removed Do not take chances. <u>3. G. Select a Solution</u> 3. G. (2) (b) 3. G. (2) (c) Removed Dairyland brand 3. G. (2) (d)	April 1, 2012	Janu- ary 1, 2018
CORR 2.29	Records <u>2. Construction Order Review Process</u> 2. B. (1) (c) Responsibility Table Updated	April 1, 2017	Janu- ary 1, 2018
CORR 3.14	Test Lead Wire Attachment <u>4. Material List</u> 4. A. 4. B. <u>7. Test Lead Attachment Coating</u> 7. A. 7. C. 7. C. (3)	Janu- ary 1, 2016	Janu- ary 1, 2018
DAMG 1	Requirements <u>4. JULIE Ticket Transmittal</u> 4. A. (1) (c) 4. A. (5) (d) Removed the word "hand" 4. A. (6) (a) Removed Service Record Card within ClickMobile <u>4. B. Emergency Excavation Tickets</u> 4. B. (1)	Janu- ary 1, 2016	Janu- ary 1, 2018

4. B. (2) (b) Removed call-back

8. Excavating Near a Transmission, High Pressure Distribution, or 8" and Larger Steel Main

8. D.

8. F.

9. Emergency Locate Request Near a Transmission, High Pressure Distribution, or 8" and Larger Steel Main

9. B. Removed the word "pending"

**EMER
0**

Table of Contents

January 1,
2016

January 1,
2018

EMER 4: Added Emergency Gas Meter Status Record

Removed Ameren Gas Emergency Relight User's Guide

Removed the Ameren Gas Emergency Relight User's Guide.

Changed Reference number for Electric Cold Load Restoration Policy

**EMER
2.01**

Customer Contact Center

January 1,
2016

January 1,
2018

Revised to be consistent with Call Center script

3. Items to Remember When Handling a Gas Leak Call

3. A.

3. B.

4. Emergency Gas Call

4. A.

4. B.

4. C.

4. D.

4. E.

4. F.

4. G.

4. G. (1)

4. G. (2)

4. G. (3)

4. H. (2)

4. K.

4. M.

5. Calls from Emergency Agencies

5. A.

7. Receiving a Carbon Monoxide Call

7. B.

8. Call Received from a Police or Fire Department

8. B.

9. Call Received from a Customer

9. A. (1)

9. A. (3)

9. A. (4)

9. B. (1)

9. B. (4)

9. B. (5)

9. C. (3)

9. C. (4)

**EMER
2.02**

Dispatch Center

Updated the automated call-out system to ARCOS

Janu-
ary 1,
2016

Janu-
ary 1,
2018

3. Cold Weather Electric Outage and Restoring Electric Service

3. C.: Expanded the Contact List to include both Gas Tech Services personnel and Gas Planning personnel and their assigned Divisions.

**EMER
2.03**

Emergency Responder

Janu-
ary 1,
2011

Janu-
ary 1,
2018

1. General

1. B.

2. Upon Arrival (Inside Leak)

2. A.

2. C.

2. F.

2. G.

2. H.

3. Upon Arrival (Outside Leak)

3. A.

4. Upon Arrival (Cut Main or Service)

4. A.

4. C.

EMER 2.04	<p>Gas Field Personnel</p> <p><u>5. Gas in a Sewer - Hazardous Condition</u></p> <p>5. E. (2) Removed near the front corner of the structure</p> <p><u>6. Fire, Ignition or Explosion - Gas Related</u></p> <p>6. F. (1) Removed if gas service needs to be temporarily disconnected.</p> <p>6. F. (3) Removed the word "visually"</p> <p><u>7. Fire, Ignition or Explosion - Not Gas Related</u></p> <p>7. B. (1) Removed if gas service needs to be temporarily disconnected.</p> <p>7. C. Removed the word "visually"</p> <p><u>8. Explosion and/or Fire Near Gas Pipeline Facilities</u></p> <p>8. H. (1)</p> <p>8. I.</p> <p><u>9. Train Derailment near Pipeline Facilities</u></p> <p>9. B.</p> <p><u>11. High Pressure Situation</u></p> <p>11. C.</p> <p><u>12. Loss and Restoration of Service</u></p> <p>12. E. Removed Ameren Emergency Relight User's Guide</p> <p>12. F. (7)</p> <p>12. G. (4)</p> <p>12. I. (5)</p> <p>12. K. (3)</p> <p>12. L. (4)</p> <p>12. N. (3) Removed thermocouples</p> <p>12. N. (5) Deleted this item completely</p> <p>12. R. (1)</p> <p>12. S. (9)</p> <p>12. S. (10)</p>	<p>Janu- ary 1, 2016</p>	<p>Janu- ary 1, 2018</p>
EMER 2.05	<p>Natural Disasters or Civil Disobedience</p> <p><u>3. Floods</u></p> <p>3. A. (3)</p> <p>3. C. (6)</p>	<p>Janu- ary 1 2016</p>	<p>Janu- ary 1 2018</p>

EMER 2.07	Emergency Response Review <u>2. Written Report</u> 2. A. 2. B. 2. D.	January 1 2011	January 1 2018
EMER 4	Forms and Reference Materials Added Emergency Gas Meter Status Record Removed Ameren Gas Emergency Relight User's Guide	January 1 2016	January 1 2018
EXCV 0	Table of Contents EXCV 2.01 Excavation Flowchart is being removed EXCV 4: Added: Speed Shore's Aluminum Panel Shields Tabulated Data Speed Shore's MAPS-B Tabulated Data	January 1 2016	January 1 2018
EXCV 2.01	Prior to Excavation <u>1. Job Site Inspection</u> 1. A. 1. B. <u>2. Job Preparation</u> 2. E. 2. F. Deleted former 2. C.; 2. G. 2. J.	January 1 2014	January 1 2018
EXCV 2.02	Excavation Flowchart Removed this section	January 1 2014	January 1 2018
EXCV 2.03	Work in Excavation <u>1. Beginning Excavation</u> 1. D. (2) 1. E.	January 1 2014	January 1 2018
EXCV 2.09	Working in Hazardous Atmosphere <u>5. Hazardous Concentration of Natural Gas - Level 2 PPE Requirement</u> Replaced previous text with reference and link to WWBG 2.01	January 1 2016	January 1 2018

EXCV 4	Forms and Reference Materials Added: Speed Shore's Aluminum Panel Shields Tabulated Data Speed Shore's MAPS-B Tabulated Data	Janu- ary 1 2016	Janu- ary 1 2018
<u>GLOS</u>	Glossary Added Odorant Intensity Testing Sniff Test	April 1, 2017	Janu- ary 1 2018
INVE 2.01	Incident Investigation <u>2. Investigation Documentation</u> 2. D.	Janu- ary 1, 2016	Janu- ary 1, 2018
INVE 2.02	Investigation of Fires <u>1. General</u> 1. B. <u>2. Fire, Ignition or Explosion Investigation</u> 2. B. <u>5. Communications with Fire Departments</u> 5. C. <u>6. Communication with the Media</u> 6. B.	Janu- ary 1, 2016	Janu- ary 1, 2018
<u>LEAK</u> 0	Table of Contents LEAK 2.04 6. Corrected Upgrading from Uprating LEAK 4: Updated: Southern Cross Flame Pack Series 400 Manual (5-27-2015) Sensit Gold G2 Manual (Revision 7-1-2015) Sensit IRED Manual (Revision 12-6-2016) Added: MBW Vapor Extraction Unit (VEU) iTrans Gas Monitor Manual	Sep- tember 1, 2016	Janu- ary 1 2018
LEAK 2.04	Leak Classification and Surveillance 2. F.	De- cem- ber 1, 2014	Janu- ary 1, 2018

UNCONTROLLED IF PRINTED

6. Upgrading a Leak replaced Uprating a Leak.

6. A.

6. B.

7. Foreign Gas

7. B.

8. Leak Surveillance, Repair, and Recheck Schedule

8. C. (1) (c)

10. Repaired Leak Recheck

10. B. (1)

11. Records

Deleted former 11. A. & B. since were not records.

11. A.

LEAK 2.11	Leak Surveys - Records and Maps <u>1. Additional Survey Checks</u> 1. B. (6) <u>2. Maps and Records</u> Gas Compliance Specialist changed to Gas Compliance in the following sections 2. A., 2. C., 2. E.	De- cem- ber 1, 2014	Janu- ary 1, 2018
LEAK 2.12	Reporting Delayed Leak Response Time 3. Monitoring Investigation and Reporting Process Gas Compliance replaced Gas Compliance Specialist throughout this section.	Janu- ary 1, 2011	Janu- ary 1, 2018
LEAK 4	Forms and Reference Materials Updated: Southern Cross Flame Pack Series 400 Manual (5-27-2015) Sensit Gold G2 Manual (Revision 7-1-2015) Sensit IRED Manual (Revision 12-6-2016) Added: MBW Vapor Extraction Unit (VEU) iTrans Gas Monitor Manual	Sep- tember 1, 2016	Janu- ary 1, 2018
MAIN 0	Table of Contents Revise MAIN 2.05 Pipe Coating and Gasket Removal	Janu- ary 1, 2016	Janu- ary 1, 2018

MAIN 1	Requirements <u>3. Cover</u> 3. D. <u>5. Trench Requirement</u> 5. C. <u>6. Excavation and Work Area Protection</u> 6. B. <u>7. Laying and Lowering</u> 7. D. <u>9. Joining</u> 9. D. <u>15. Pressure Testing</u> 15. C. <u>20 Records</u> 20 A. (1)	Janu- ary 1, 2016	Janu- ary 1, 2018
MAIN 2.01	Joint Trench <u>2. Gas/Electric Joint Trench Installation</u> 2. A. (2) 2. B.	April 1, 2013	Janu- ary 1, 2018
MAIN 3.04	In all of these Standards, revised the description for: Transition Fitting, PE to Steel, with Protective Sleeve from	Janu- ary 1, 2011	Janu- ary 1, 2018
MAIN 3.05	Sleeve, PE to Steel, Transition.		
MAIN 3.18			
MAIN 3.19			
MAIN 3.20			
MAIN 3.15	In all of these Standards, revised the description for: Transition Fitting, PE to Steel, with Protective Sleeve from	July 1, 2014	Janu- ary 1, 2018
MAIN 3.16	Sleeve, PE to Steel, Transition.		
MAIN 3.17			

METR 0	<p>Table of Contents</p> <p>METR 3.14 425 Meter, By-Pass, 2 and 5 PSIG Delivery, 5-60 PSIG Inlet</p> <p>Change Heading since no longer approved for 10 psig delivery</p> <p>METR 4:</p> <p>Updated Itron B31, B42, CL34, CL31 Series Regulator manuals</p> <p>Added:</p> <p>Fisher 299H Relief Valve manual</p>	January 1, 2017	January 1, 2018
METR 2.03	<p>Sample Testing</p> <p><u>3. Sample Technique Criteria</u></p> <p>3. A. Removed Military Standard 105D</p>	January 1, 2017	January 1, 2018
METR 2.14	<p>Electronic Corrector Inspection</p> <p><u>5. Temperature Verification</u></p> <p>5. A.</p> <p><u>6. Maintenance Activities</u></p> <p>6. C. (2)</p> <p>6. C. (4)</p>	January 1, 2017	January 1, 2018
METR 2.15	<p>Elevated Metering Pressure</p> <p><u>6. Records</u></p> <p>6. A.</p>	January 1, 2017	January 1, 2018
METR 2.22	<p>Pressure Gauges</p> <p><u>6. Verification and Calibration</u></p> <p>6. A. (3): its replaced it's</p> <p><u>8. Accuracy Verification Table</u></p> <p>Added Stock Codes for Ashcroft 1084 Test Gauges</p>	January 1, 2017	January 1, 2018
METR 2.24	<p>Replacement of Large Volume Diaphragm Meters</p> <p><u>3. Inspecting Customer Piping and Appliances</u></p> <p>3. B.: Deleted the "a" before Warning tag</p> <p><u>4. Meter and Regulator Inspection</u></p> <p>4. A.</p>	January 1, 2017	January 1, 2018

METR 2.25	Ultrasonic Meter Testing 5. Inspection Records 5. B.: Removed the need to print a copy of configuration	January 1, 2017	January 1, 2018
METR 2.26	New Meter Testing <u>3. Sample New Diaphragm Meters</u> 3. A. Removed Military Standard 105D 3. D.: 3. D. Table <u>4. Sample Selection New Diaphragm Meters</u> 4. B.	January 1, 2017	January 1, 2018
METR 2.27	Electronic Corrector Installation Verification <u>1. General</u> 1. C. <u>2. Electronic Corrector Verification Schedule</u> 2. A. 2. B. 2. C. <u>3. Device Programming Verification</u> 3. A. 3. A. (7) <u>5. Corrector Edit Calculation</u> 5. A. <u>6. Documentation Activities</u>	January 1, 2017	January 1, 2018
METR 3.02	Existing Meter Sizing <u>4. Existing Rotary Meter Installations</u> Corrected 3 flow capacities at 2 psig.	January 1, 2016	January 1, 2018
METR 3.08	175 - 250 Meter - 7 inch W.C. Delivery Added the Itron B42R	January 1, 2013	January 1, 2018
METR 3.16	630 Meter - Bypass - 7 inch W.C. Delivery Added the Itron B42R	April 1, 2013	January 1, 2018

METR 4	Forms and Reference Materials Updated Itron B31, B42, CL34, CL31 Series Regulator manuals Added: Fisher 299H Relief Valve manual	Janu- ary 1, 2017	Janu- ary 1, 2018
OQAL 0	Table of Contents OQAL 1: Inserted Disqualification in item 7. and moved Ameren Illinois Covered Task List to its own section, OQAL 2.01	Janu- ary 1, 2016	Janu- ary 1, 2018
OQAL 1	Requirements <u>4. Covered Tasks</u> 4. A. 4. B. <u>6. Evaluation Guidelines</u> 6. B. (2) 6. E. (1) 6. E. (2) <u>8. Non-Qualified Individuals</u> 8. A. (3) 8. A. (4) <u>11. Management of Change</u> 11. A. <u>13. Contractors</u> 13. C. 13 E. (2) (e) <u>14. OQ Review Meeting</u> 14. C. (1) (a) Removed the 30 day grace period for Contractor's new hires to become qualified 14. C. (1) (b) <u>15. Training</u> 15. B.	Janu- ary 1, 2016	Janu- ary 1, 2018
OQAL 2.01	Covered Task List Separated the Cover Task List from OQAL 1 into its own section.	New	Janu- ary 1, 2018

<p>POLY 0</p>	<p>Table of Contents</p> <p>POLY 2.03 Heat Fusion Joining - Removed</p> <p>POLY 2.05 Electrofusion - Combined Caps with Couplings, added Repair Saddles with the Service Tees</p> <p>POLY 3.02 - Added Repair Saddles.</p>	<p>January 1, 2016</p>	<p>January 1, 2018</p>
<p>POLY 2.03</p>	<p>Heat Fusion Joining - Removing, language was incorporated in POLY 2.04 Butt Fusion</p>	<p>May 1, 2010</p>	<p>January 1, 2018</p>
<p>POLY 2.04</p>	<p>Butt Fusion</p> <p><u>1. General</u></p> <p>1. A.</p> <p><u>4. Joint Assembly</u></p> <p>4. B. (5)</p> <p>4. L.</p> <p>4. N. Removed (within 3 seconds)</p> <p>4. Q. Table</p>	<p>July 1, 2012</p>	<p>January 1, 2018</p>
<p>POLY 2.05</p>	<p>Electrofusion</p> <p><u>1. General</u></p> <p>1. B.</p> <p><u>2. Equipment, Weather and Cleanliness Guidelines</u></p> <p>2. C.</p> <p>2. H.</p> <p>2. I.</p> <p><u>3. Electrofusion Couplings and Caps</u></p> <p><u>3. A. Preparation Prior to Scraping</u></p> <p>3. A. (3)</p> <p><u>3. B. Scraping</u></p> <p>3. B. (1)</p> <p>3. B. (1) Note on Kerotest rotating scraper</p> <p>3. B. (2)</p> <p><u>3. C. Joint Assembly</u></p> <p>3. C. (1)</p> <p>3. C. (2)</p> <p>3. C. (3)</p>	<p>January 1, 2016</p>	<p>January 1, 2018</p>

3. C. (4)

3. C. (5)

3. C. (6)

4. Electrofusion Service Tees, High Volume Tees or Repair Saddles

4. A. Preparation Prior to Scraping

4. A. (1)

4. A. (4)

4. B. Scraping

4. B. (2)

4. B. (3)

4. C. Fusion

4. C. (3)

4. C. (6)

6. Electrofusion Elbows

6. A. Preparation Prior to Scraping

6. A. (3)

6. A. (6)

6. B. Scraping

6. B. (2)

7. Cooling Times

Central Plastic EF Fittings update

POLY 3.02	Electrofusion Fittings <u>8. Repair Saddles</u> - New Added the Stock Codes for the 4" and 6" repair saddle	Janu- ary 1, 2016	Janu- ary 1, 2018
PRES 1	Requirements 1. C.	Janu- ary 1, 2013	Janu- ary 1, 2018
PTST 0	Table of Contents PTST 4 Updated Leak Test and Leak & Strength Test forms	Sep- tember 1, 2016	Janu- ary 1, 2018
PTST 1	Requirements <u>2. Test Medium</u> 2. A.	April 1, 2017	Janu- ary 1, 2018

2. Table - New

9. Test Records

9. A.

9. A. (1)

9. A. (2)

9. A. (3)

Removed samples of Leak Test Form and Leak & Strength Test Record

PTST 2.04	Nitrogen Pressure Testing <u>1. General</u> 1. B. <u>3. Cylinder Requirements</u> 3. A. 3. C. (1) 3. C. (2) <u>5. Tube Trailer Requirements</u> 5. B.	April 1, 2012	Janu- ary 1, 2018
PTST 2.05	MAOP Determination 2. MAOP Determination 2. C. - Removed promulgation of	July 1, 2014	Janu- ary 1, 2018
PTST 4	Forms and Reference Materials Updated Forms Form 01 - Leak Test Form - LTF17 Form 02 - Leak & Strength Test Form - LSTF17 Added SharePoint Site link where the most current forms are maintained.	Sep- tember 1, 2016	Janu- ary 1, 2018
PUBL 0	Table of Contents PUBL 4 - Updated Reference Materials	Janu- ary 1, 2016	Janu- ary 1, 2018
PUBL 1	Requirements 1. C. (1)	Janu- ary 1, 2014	Janu- ary 1, 2018
PUBL 2.01	Public Notifications <u>1. General</u> 1. A.	Janu- ary 1, 2016	Janu- ary 1, 2018

- 1. C.
- 2. Gas Safety Notifications to New Customers
- 2. B.
- 2. B. (7)
- 3. Gas Safety Notifications to General Public
- 3. B.
- 3. C.
- 4. Pipeline Emergency Response Notification to Government Organizations
- 4. A.
- 4. C. (1)
- 4. C. (2)
- 4. D.

PUBL 2.02	Liaisons With Fire, Police, and Public Officials <u>3. Mailings</u> 3. C. <u>4. Face-to-Face Visit</u> 4. A. (2) 4. A. (3) 4. A. (4) <u>5. Natural Gas Emergency Procedure</u> 5. A. Removed fire, law enforcement since they are included in Emergency Personnel.	Janu- ary 1, 2016	Janu- ary 1, 2018
PUBL 4	Forms and Reference Materials Updated Reference Materials	Janu- ary 1, 2016	Janu- ary 1, 2018
QUAL 0	Table of Contents QUAL 4 - Added Form 20 - NDT Radiographic Inspection	Janu- ary 1, 2016	Janu- ary 1, 2018
QUAL 4	Forms and Reference Materials Added Form 20 - NDT Radiographic Inspection	Janu- ary 1, 2016	Janu- ary 1, 2018
REGS 0	Table of Contents REGS 4 Updated all of the Standardized Regulator Station Design pdf drawings	De- cem- ber 1, 2014	Janu- ary 1, 2018

<p>REGS 2.01</p>	<p>Regulator Station Inspection</p> <p>1. B. (3)</p> <p><u>2. Available Resources or Equipment</u></p> <p>2. A. (2)</p> <p><u>3. Operational Inspection</u></p> <p>3. D. (6) (b)</p> <p><u>5. Acoustical inspection</u></p> <p>5. D.</p>	<p>De- cem- ber 1, 2014</p>	<p>Janu- ary 1, 2018</p>
<p>REGS 2.03</p>	<p>Bypass Operations</p> <p>1. E. (8)</p>	<p>Octo- ber 1, 2011</p>	<p>Janu- ary 1, 2018</p>
<p>REGS 2.04</p>	<p>Troubleshooting Common Regulator Problems</p> <p>1. A.</p> <p>1. C.</p> <p><u>3. Blowing Relief Valve</u></p> <p>3. B. (1) (b)</p> <p>3. B. (2) (b)</p> <p>3. B. (2) (c) Removed "or a slight increase in flow through the relief valve is noticed"</p> <p>3. B. (3)</p> <p><u>4. Low System Pressure</u></p> <p>4. G.</p>	<p>Octo- ber 1, 2011</p>	<p>Janu- ary 1, 2018</p>
<p>REGS 2.06</p>	<p>Gas Heaters</p> <p><u>3. Indirect Heaters</u></p> <p>3. B. (3) Removed brand name, Kimray Thermostat)</p> <p>3. C. (1)</p> <p>3. C. (3)</p> <p>3. D. (2)</p> <p>3. D. (14) (a)</p> <p>3. E. (4)</p>	<p>Octo- ber 1, 2011</p>	<p>Janu- ary 1, 2018</p>
<p>REGS 3.01</p>	<p>Regulator Station Design</p> <p><u>2. General Guidelines and Requirements</u></p> <p>2. C.</p> <p>2. G.</p>	<p>Octo- ber 1, 2011</p>	<p>Janu- ary 1, 2018</p>

2. H.

2. I.

**REPR
0**

Table of Contents

Janu-
ary 1,
2014

Janu-
ary 1,
2018

REPR 1

3. High Pressure Distribution and Transmission Pipe Repair -
Replaced Repair Methods

4. Steel Distribution Pipe Repair - Added Distribution

Removed: - Information was incorporated in reorganized sec-
tions:

Approved Repair Methods

Distribution Main Repairs

Service Line Repairs

**REPR
1**

Requirements

De-
cem-
ber 1,
2014

Janu-
ary 1,
2018

1. Objective

1. B.

3. High Pressure Distribution and Transmission Pipe Repair

3. N.

4. Steel Distribution Pipe Repair

4. A.

4. B.

4. F. (6)

4. K. Composite Wrap System

4. K. (4)

4. K. (5)

4. L. Weld Deposition

4. L. (1)

4. M: Stainless Steel Bolted Leak Clamp

4. M. (1)

4. M. (2)

4. M.(3)

4. N. Tapered Screw Plug

4. N. (4)

4. O. Encapsulation

4. O. (1)

4. O. (2)

UNCONTROLLED IF PRINTED

	<u>5. PE Pipe Repair</u>		
	5. G.		
	5. H.		
RNST 0	Table of Contents RNST 2.01 5. Abandoned Main replaces Abandoned Line	April 1, 2012	Janu- ary 1, 2018
RNST 2.01	Reinstating Mains and Services <u>2. Reconnection of Temporarily Disconnected Services</u> 2. B. 2. F. Removed a valve between the main and service and re- placed with valve on service line. <u>3. Reconnection of Temporarily Disconnected Farm Tap Ser- vices</u> 3. B. (3) Typo on t0 should be to 3. C. <u>4. Reconnection of Temporarily Disconnected Mains</u> 4. A. 4. B. 4. C. 4. D. <u>5. Reinstating Service in Abandoned Mains</u> 5. A. (1) 5. A. (2) 5. A. (4) 5. B.	Sep- tember 1, 2016	Janu- ary 1, 2018
SERV 2.08	Insertion <u>4. Dead Insertion</u> 4. L. 4. Y.	April 1, 2017	Janu- ary 1, 2018
SERV 3.06	Farm Tap - Single Cut, 60-450 PSIG Inlet Pressure Corrected a couple of stock codes	April 1, 2017	Janu- ary 1, 2018
SERV 3.07	Farm Tap - Double Cut, 451-1000 PSIG Inlet Pressure Corrected a stock code	April 1, 2017	Janu- ary 1, 2018

STLP 1	<p>Requirements</p> <p><u>3. Joining</u></p> <p>3. A.</p> <p><u>10. Buried Pipe Examination</u></p> <p>Clarified an examination is required for steel pipe being left in service after the DOJM/WO has been finalized.</p>	Janu- ary 1, 2016	Janu- ary 1, 2018
STLP 2.01	<p>Design Pressure</p> <p><u>7. Steel Pipe Stock Code Table</u></p> <p>In title block added Minimum to Yield strength</p> <p>Made 3 corrections in the table for 16 and 18 inch pipe.</p> <p>In the Notes section, (2) added Class 3 design factors,</p> <p>(4) Added pipe grades which will be included in the multi-sten- ciled pipe, (6) added the location where approved pipe speci- fication can be found on Gas Operations & Services Share- Point site.</p>	Janu- ary 1, 2016	Janu- ary 1, 2018
TAPS 2.06	<p>TDW PE Branch Saddle Valve</p> <p><u>8. Completing</u></p> <p>8. J.</p>	Janu- ary 1, 2011	Janu- ary 1, 2018
TAPS 3.01	<p>Mueller Fittings</p> <p><u>3. Line Stopper Fittings</u></p> <p>Added Shim</p> <p><u>For Use on Standard Wall Steel Pipe</u></p> <p>Added tow fittings: 4" x 3" and a 6" both are 1440 psig</p> <p><u>4. Mueller Bottom-Out Line Stopper Fittings</u></p> <p>Removed a 2", 1200 psig fitting</p> <p>Added Shim</p> <p><u>For Use on Standard Wall Steel Pipe with Schedule 40 Bot- tom Opening</u></p> <p>Added a 8" fitting 720 psig</p> <p><u>9. Mueller Pig Plugs - Line Stopper Fitting Insert</u></p> <p>This is a new section and lists stock codes for 6" thru 12".</p>	Janu- ary 1, 2016	Janu- ary 1, 2018
TAPS 3.02	<p>T.D. Williamson Fittings</p> <p><u>3. SHORTSTPP Spherical 3-Way Tee</u></p> <p>Added 3" ANSI Class 300, Threaded</p>	Janu- ary 1, 2016	Janu- ary 1, 2018

TURN 0	Table of Contents TURN 2.03 Discontinuance or Transfer of Gas Service Deleted 5. Sealing of a Locked Off Meter Valve Deleted 6. Structure Being Demolished TURN 2.07: 6. Installation in Manufactured Home TURN 2.13: Appliance Safety	Janu- ary 1, 2016	Janu- ary 1, 2018
TURN 2.03	Discontinuance or Transfer of Gas Service <u>1. General</u> 1. B.: <u>2. Read In-Read Out</u> 2. C. <u>Soft Disconnect (Leave Hot)</u> 3. A. 3. B. <u>4. Hard Disconnect (Terminate Service)</u> 4. A. 4. A. (1) thru (5) 4. B. 4. B. (1) 4. B. (2) 4. C. 4. E. 4. E. (1) thru (4) 4. F.	Janu- ary 1, 2011	Janu- ary 1, 2018
TURN 2.07	Lighting Appliance - Vent Free Appliance <u>1. General</u> 1. A. <u>2. Supplemental Heat Source Only</u> 2. A. 2. B. <u>6. Installation in Manufactured Homes - New</u> Removed Oxygen Depletion Safety (ODS)	Janu- ary 1, 2011	Janu- ary 1, 2018

TURN 2.08	Combustion and Ventilation Air <u>1. General</u> 1. B. <u>2. Minimum Required Volume</u> 2. B. <u>3. Circulating Air</u> 3. B. <u>4. Requirement for Combustion and Ventilation Air</u> 4. A. Removed NFPA reference 4. B. Removed NFPA reference 4. D. <u>5. Louvers and Grills</u> 5. B. Removed NFPA reference	Janu- ary 1, 2011	Janu- ary 1, 2018
TURN 2.10	Corrugated Stainless Steel Tubing - CSST <u>1. General</u> 1. A. 1. B. Moved from 2. Inside Installation 1. C. Moved from 2. Inside Installation <u>2. Inside Installation</u> 2. B. Removed NFPA reference <u>3. Outside Installation</u> 3. B. Removed former 3. C. concealed connections Removed former 3. D. malleable fittings Removed former 3. E. no corrosive liquids use to test for leak	Janu- ary 1, 2011	Janu- ary 1, 2018
TURN 2.13	Appliance Safety (Removed Thermocouple Tests) <u>1. General</u> 1. A. Removed thermocouple <u>2. Appliance Safety Check</u> 2. E. 2. G. 2. I. 2. J. Removed NFPA reference	Janu- ary 1, 2011	Janu- ary 1, 2018

UPRT 1	Uprating <u>1. Objective</u> 1. D. <u>3. Increasing MAOP To or Above 100 PSIG</u> 3. A. 3. B. Removed Gas Operations and Services	Octo- ber 1, 2011	Janu- ary 1, 2018
VALV 2.03	Plug Valve Maintenance 8. Lubricants 8. D. Table and Notes	Janu- ary 1, 2016	Janu- ary 1, 2018
VALV 3.02	Steel Ball Valves 2. Stock Code Tables with Associated Valve Box Updated pressure ratings from 275 to 285 psig	Janu- ary 1, 2016	Janu- ary 1, 2018
VALV 3.03	Kerotest Gate Valves 2 Stock Code Table Updated pressure ratings from 275 to 285 and from 720 to 740 psig.	Janu- ary 1, 2011	Janu- ary 1, 2018
VALV 3.04	Steel Plug Valves 2. Stock Code Tables with Associated Valve Box Updated pressure ratings from 275 to 285 and from 720 to 740 psig.	Janu- ary 1, 2011	Janu- ary 1, 2018
WELD 0	Table of Contents WELD 2.06 Changed to Radiographic Testing and expanded section headings. Updated Reference Materials - Welding Procedures (WPSs)	Janu- ary 1, 2016	Janu- ary 1, 2018
WELD 2.03	Construction of Pipelines and Piping Systems <u>8. Welding Requirements</u> <u>8. A. Electrodes</u> 8. A. (1) (c) <u>8. N. Weld Pass Requirements</u> 8. N. (3) <u>8. O. Preheating of Welds</u> 8. O. (1) 8. U. Pipe Coating Protection	Janu- ary 1, 2016	Janu- ary 1, 2018

	8. U. (1)		
	8. U. (2)		
WELD 2.04	In-Service Welding	Janu- ary 1, 2016	Janu- ary 1, 2018
	<u>2. Referenced Codes and Standards</u>		
	2. C.		
	<u>4. D. Hot Tap fittings</u>		
	4. D. (1) Remove the steel band language		
	4. D. (2)		
	<u>5. Welder Qualification</u>		
	<u>6. Welding Procedures</u>		
	<u>6. B. Wall Thickness Survey</u>		
	6. B. (2)		
	6. C. In-Service Welding Electrode Requirements		
	6. C. (4)		
	6. C. (7)		
WELD 4	Forms and Reference Materials	Janu- ary 1, 2016	Janu- ary 1, 2018
	Updated all of the Welding Procedures (WPSs)		
WW- BG 0	Table of Contents	Janu- ary 1, 2016	Janu- ary 1, 2018
	WWBG 2.01 - Removed 6. PPE Requirements		
WW- BG 1	Requirements	Janu- ary 1, 2016	Janu- ary 1, 2018
	<u>1. Objective</u>		
	1. F.		
	<u>2. Definitions</u>		
	2. C.		
WW- BG 2.01	Hazardous Atmosphere	Janu- ary 1, 2016	Janu- ary 1, 2018
	<u>2. Identifying a Hazardous Outdoor Atmosphere</u>		
	2. C. (1):		
	<u>3. E. Establishing a Safe Zone</u>		
	3. E. (8):		
	<u>4. Working in a Hazardous Atmosphere</u>		
	4. G. (1)		
	4. G. (3)		

4. G. (4)

4. G. (6)

Supersedes: April 1, 2017

CHANGE SUMMARY		April 1, 2017	
Change Summary April 1, 2017			
Docu- ment	Change Summary	Previ- ous Docu- ment Dated	Current Docu- ment Dated
OPERATIONAL PROCEDURAL CHANGES			
CORR 1	<p style="text-align: center;">3. Corrective Action</p> <p>3. A.: A deficient Pipe to Soil reading has been changed to -0.950 v from -0.900 v.</p> <p style="text-align: center;">4. Cathodic Protection of New and Replacement Pipeline Facilities</p> <p>4. B.: All new and replacement steel pipeline facilities shall have a measured cathodic protection level of -0.950 volts or more within one year after completion of construction. Changed from -0.900 v.</p> <p style="text-align: center;">6. External Corrosion</p> <p>6. B.: Maximo will send Corrosion Control personnel a report where pipe to soil readings are -0.950 v or less.</p> <p>Above revisions made to be consistent with how Corrosion Control had Maximo changed in 2016 to identify deficient pipe to soil readings.</p> <p style="text-align: center;">13. Atmospheric Corrosion</p> <p style="text-align: center;">13. B. Monitoring</p> <p style="text-align: center;">13..B.(1): Added "for atmospheric corrosion"</p>	Janu- ary 1, 2016	April 1, 2017
CORR 2.02	<p style="text-align: center;">Anode Requirements</p> <p style="text-align: center;">4. Anode Requirements</p> <p style="text-align: center;">4. B. Service lines:</p> <p style="text-align: center;">4. B. Table: -0.950 v replaced -0.900 v</p> <p style="text-align: center;">4. D. Isolated services:</p> <p style="text-align: center;">4. D. Table - -0.950 v replaced -0.900 v</p> <p style="text-align: center;">Consistent with CORR 1</p> <p>Moved the PE Main Locator Wire item to POLY 1 for anode attached to tracer wire.</p>	July 1, 2014	April 1, 2017
DAMG 2.01	<p style="text-align: center;">Reporting JULIE Violations</p> <p style="text-align: center;">2. Reportable Violations</p>	Janu- ary 1, 2016	April 1, 2017

UNCONTROLLED IF PRINTED

	<p>2. A. (3): Digging prior to the dig time and date on the JULIE ticket replaces Digging prior to the 48 hour notice period on the JULIE ticket.</p> <p>The JULIE ticket shows the time and date when the 48 hour notice has been met.</p> <p>3. Investigation of Reportable Violations</p> <p>3. A.: Investigation and documentation of an incident will be performed by Damage Prevention personnel only.</p> <p>Gas Supervisors no longer have to conduct an investigation nor complete an Incident Report.</p> <p>Deleted the previous 3. B. and 3. C. Since Damage Prevention personnel will be completing the Incident Report there isn't a need to have instructions on how to access the Incident Report.</p> <p>4. Reporting a Suspected Violation</p> <p>4. A. Revised to reflect the current process, Damage Prevention personnel completes the investigation and the Incident Report. The Incident Report is reviewed by Regulatory and those Incident Reports that are identified as needing to be reported are sent the ICC</p>		
<p><u>INCD 1</u></p>	<p>2. Natural Gas Incident</p> <p>2. A. (5): Added a reference to see 3. Potential Significant Events when evaluating a Natural Gas Incident to determine if the incident should be reported.</p> <p>5. Service Interruption/Curtailment Notification</p> <p>5. B.: New section added by Gas Compliance. This section requires that Gas Compliance be notified when there is a service interruption that affects more than 25 customers for 8 hours or longer.</p> <p>5. B. (1): Gas Compliance will notify ICC where interruptions affect 50 customers or more for a period of 12 hours or longer.</p> <p>5. B. (2): Gas Compliance will prepare an annual report of gas interruptions affecting 25 or more customers for 8 hours or longer and file that report with the ICC.</p> <p>7 Gas Compliance Contact List</p> <p>If the listed Gas Compliance personnel cannot be reached, Division Operations shall report the incident by calling the numbers listed under the State & Federal Contact Numbers.</p> <p>The State & Federal Contact Numbers replaced "following steps 6 through 11" since these steps don't exist.</p>	<p>January 1, 2016</p>	<p>April 1, 2017</p>

	<p style="text-align: center;">8. Reporting Matrix</p> <p style="text-align: center;">8. A.: Gas Compliance shall be contacted:</p> <p>Insert a new item in 9. Gas service interruption of 25 of more customers for duration of 8 hours or more.</p> <p style="text-align: center;">8. B.: Gas Compliance shall make following reporting contacts:</p> <p style="text-align: center;">Added: Gas service interruption of 25 of more customers for duration of 8 hours or more.</p> <p>Consistent with the new reporting procedures in INCD 1 5. Service Interruption/Curtailment Notification</p> <p style="text-align: center;">9.State & Federal Contact Numbers</p> <p>Update on PHMSA contact via National Response Center</p> <p style="text-align: center;">10. Corporate Claims Notification (CCMI)</p> <p>Nikki Clay - Claims Administrator replaced Dennis Spencer</p> <p style="text-align: center;">14. Written Incident Report</p> <p style="text-align: center;">Clarifying and updating:</p> <p>14. A.: Gas Superintendent was added as another person responsible for collecting information for the Gas Incident Investigation Log. The Log is to be forwarded to Gas Compliance.</p> <p>14. B. Gas Compliance is the group that will review the Incident Investigation Log and actually complete the Incident Report for submittal to the appropriate agencies.</p> <p>14. C. The Incident Report is completed on the appropriate form in INCD 4.</p>		
<p>LEAK 2.07</p>	<p style="text-align: center;">Leak Surveys</p> <p style="text-align: center;">2. Leak Survey Types</p> <p style="text-align: center;">2. E. Inside Meter Sets</p> <p>Removed the requirement for Gas Supervisors to maintain a list of inside meter sets and the list maintained in Maximo.</p> <p>Gas Superintendents requested this be removed since all Operating Areas do not have Inside Meter Leak Surveys.</p> <p>2. E. (4): Corrected terminology, Service line replaced primary fuel line. The inside service line to the meter set shall be checked for leaks.</p>	<p style="text-align: center;">De- cem- ber 1, 2014</p>	<p style="text-align: center;">April 1, 2017</p>
<p><u>LEAK 2.09</u></p>	<p style="text-align: center;">Leak Surveys - Walking Leak Survey</p> <p>1. K. Fenced Gas Facilities Inspected Annually - removed Monthly.in the heading for this section and throughout the 1. K. (1) thru (4).</p>	<p style="text-align: center;">Janu- ary 1, 2016</p>	<p style="text-align: center;">April 1, 2017</p>

	<p>1. K. (2): Added: If an odorizer is located within the same fenced area as the facility being annually inspected, the odorizer piping system will be included in the Leak Survey ID and documented on Leak Survey Task within ClickMobile.</p> <p>Clarification that the leak survey should be performed on the gas facilities within the fenced area which could include an odorizer.</p> <p>1. K. (3): Correction: The first leak survey on fenced transmission facilities in Class 3 location will be performed during the annual inspection and documented within ClickMobile on the appropriate inspection task. The second leak survey will be documented in ClickMobile on their own designated Leak Survey Task.</p> <p>1. K. (4): New item addresses fenced standalone odorizers. These odorizers will have their own Leak Survey Task that is handled by Gas Tech Services personnel.</p> <p>Specifically addresses leak surveys on standalone odorizers.</p> <p>1. N. Gas Detection Instrument or FI Unit Indicates a Possible Leak</p> <p>1. N. (5): If leak surveyor detects gas from a valve box and cannot get the lid off of the valve box to complete the investigation, the leak surveyor will contact local operations supervisor or his designee for assistance.</p> <p>Contract Leak Surveyors normally do not have the necessary tools to open valve box lids.</p>		
<p>PTST 1</p>	<p>8. Component Other Than Pipe Being Replaced or Added to Pipeline</p> <p>8. A. (1): Revised testing of component on pipeline with Design MAOP of "less than 100 psig" the minimum test pressure required to check for leaks is 90 psig.</p> <p>The "less than 100 psig" is consistent with Part 192.509 language and the minimum 90 psig test pressure is a standard practice for Operations in testing our distribution pipe and facilities.</p> <p>8. A. (2): With the revision in (1), had to change Design MAOP to 100 psig or greater.</p>	<p>Sep-tem-ber 1, 2016</p>	<p>April 1, 2017</p>
<p>SERV</p>	<p>The revisions in the following SERV sections are associated with PHMSA's new EFV rules which become effective for all new or replaced services installed after April 14, 2017. Under PHMSA's new rules residential multi-family service line and all commerce service lines will require either properly sized EFV or a manual service line shut-off valve to be installed. Single family res-</p>		

	idential service line and residential branch service line will continue to require an EFV.		
SERV 1	<p style="text-align: center;">Service Line Installation Requirements</p> <p style="text-align: center;">1. Objective</p> <p>1. B.: Added reference to SERV 2.02 2. Residential Service for EFV requirements and SERV 2.02 5. Manual Service Line Shut-Off Valve requirements</p> <p>1. C.: Added reference to SERV 2.02 3. Commercial Service for EFV requirements and SERV 2.02 5. Manual Service Line Shut-Off Valve requirements.</p> <p style="text-align: center;">6. Valve Requirements</p> <p>6. C.: Manual service line shut-off valve replaces property line valve.</p> <p>6. E.: After April 14, 2017, a manual service line shut-off valve shall be installed on all new or replaced multi-family residential or commercial service lines where a properly sized EFV cannot be installed.</p> <p>6. F.: Manual service line shut-off valve replaces underground service line valve and added valve box should be located so that it can be safely accessed and is aligned to allow access for valve wrench.</p> <p style="text-align: center;">11. Excess Flow Valves</p> <p style="text-align: center;">Added references to SERV 2.02 2. and SERV 2.02 3.</p>	January 1, 2017	April 1, 2017
SERV 2.02	<p style="text-align: center;">Excess Flow Valve or Manual Shut-Off Valve - Revise title</p> <p>SERV 2.02 has basically been totally revised. SERV 2.02 2.: Addresses Residential Service Requirements 2.02 3.: Addresses Commercial Service Requirements for both EFVs and manual service line shut-off valves.</p> <p>Under the new PHMSA rules, we are still required to install EFVs on all new and replaced individual or branched residential service line and on individual commercial services with connected load of 1,000 scfh or less.</p> <p>Beginning with new or replaced service lines installed after April 14, 2017, a properly sized EFV shall be installed on multi-family residential and commercial services lines where the installed or proposed to be installed meter rate capacity is 1,000 scfh or less. If the meter rated capacity exceeds 1,000 scfh, a properly sized EFV should be installed or a manual service line shut-off valve.</p>	January 1, 2016	April 1, 2017

	<p>SERV 2.02 5.: Addresses Manual Service Line Shut-Off Valve Installation</p> <p>SERV 2.02 6.: Addresses the Inspection and Maintenance of the manual service line shut-off valves. These valves are subject to an inspection every 5 years.</p> <p>SERV 2.02 7.: Under PHMSA’s new rule all existing customers, residential and commercial, shall be notified of their right to request an EFV to be installed on their existing service line as long as their existing meter rated capacity does not exceed 1,000 scfh and the service line does not qualify for one of the exceptions for an EFV. The installation of an EFV will be at the customer’s expense.</p> <p>Ameren Communications and Public Relations will manage the notification process.</p> <p>8. EFV Sizing</p> <p>8. G.: Table for 3/4 inch steel EFV:</p> <p>Added Max Flow for Inlet Pressures 10 psig thru 50 psig for those situations where an existing customer wanted an EFV installed on existing 3/4 inch steel service line.</p> <p>9. EFV and Manual Shut-Off Valve identification</p> <p>9. B.: Added the location of manual service line shut-off valve shall be identified on the Gas Service Card Form in ClickMobile and retained in Maximo. The valve will be indicated on Ameren Illinois electronic mapping system.</p>		
<p>SERV 2.03</p>	<p>Farm Tap Installations</p> <p>2. Standard Installation</p> <p>2. G.: Added reference to SERV 2.02 2. D. Residential Service Requirement for more information.</p> <p>2. H.: Added a separate section for commercial farm taps since commercial service now require EFV or a manual service line shut-off valve. References to SERV 2.02 3. G. Commercial Service Requirements and SERV 2.02 5. Manual Service Line Shut-Off Valve requirements.</p> <p>2. I.: Added: Since the farm tap design has the outlet pressure of the regulator set at between 15 and 20 psig, the service line should be a minimum of 1 inch with an EFV of the same size as the service line.</p> <p>Consistent with SERV 2.02 3. EFV Sizing language for inlet pressure less than 20 psig.</p> <p>5. Inlet Valves</p>	<p>Sep-tem-ber 1, 2016</p>	<p>April 1, 2017</p>

	<p>5. B. (1): Added Single Cut and Double Cut to the Farm Tap standards SERV 3.06 and SERV 3.07.</p> <p>5. B. (4): Deleted the pipe classification, transmission and high pressure distribution 6 inch nominal diameter and larger as a restriction for the use of an AutoPerf tee. The use of an AutoPerf tee is limited by the 0.281 inch wall thickness of the pipe.</p> <p>Eliminated confusion on when an AutoPerf tee or a Curb Valve tee had to be used. The maximum wall thickness of 0.281 inch is the limit of the AutoPerf's punch.</p> <p>Added Single Cut and Double Cut to the Farm Tap standards SERV 3.06 and SERV 3.07</p> <p>6. Installation Notes</p> <p>6. E.: Updated reference SERV 2.02 8. Excess Flow Valves, EFV Sizing</p> <p>7. Farm Tap Capacity</p> <p>7. C. Double Cut Farm Tap</p> <p>Corrected Max Flow for Stock Code EFV 39 22 250 at Inlet Pressure of 400 psig to 7,120 C cfh. From 8,900.</p>		
<p>SERV 3.06</p>	<p>Farm Tap, Single Cut, 60 - 450 PSIG Inlet Pressure</p> <p>Revised the Note: Item 1 to: Maximum wall thickness that Mueller H-18101 can tap is 0.281 inches. If the pipe wall thickness is not known or cannot be verified through testing or experience to be less than 0.281, a Mueller valve tee, H-17656, or Mueller curb valve tee, H-17800, should be used in place of the AUTOPERF tee. See TAPS 2.05 3 Maximum Pipe Wall Thickness for AUTOPERF Tee.</p> <p>Eliminated confusion on when an AutoPerf tee or a Curb Valve tee had to be used. The maximum wall thickness of 0.281 inch is the limit of the AutoPerf's punch.</p> <p>See STLP 2.01 7 Steel Pipe Stock Code Table for wall thickness of stock coded steel pipe.</p>	<p>Sep-tem-ber 1, 2016</p>	<p>April 1, 2017</p>
<p>SERV 3.07</p>	<p>Farm Tap, Double Cut, 451 - 1000 PSIG Inlet Pressure</p> <p>Revised the Note: Item 1 to: Maximum wall thickness that Mueller H-18101 can tap is 0.281 inches. If the pipe wall thickness is not known or cannot be verified through testing or experience to be less than 0.281, a Mueller valve tee, H-17656, or Mueller curb valve tee, H-17800, should be used in place of the AUTOPERF tee. See TAPS 2.05 3 Maximum Pipe Wall Thickness for AUTOPERF Tee.</p>	<p>Janu-ary 1, 2016</p>	<p>April 1, 2017</p>

	<p>Eliminated confusion on when an AutoPerf tee or a Curb Valve tee had to be used. The maximum wall thickness of 0.281 inch is the limit of the AutoPerf's punch.</p> <p>See STLP 2.01 7 Steel Pipe Stock Code Table for wall thickness of stock coded steel pipe.</p>		
	CORRECTIONS, UPDATES & NEW MATERIALS		
BORE 0	<p>BORE 4 Forms and Reference Materials</p> <p>Added:</p> <p>Door Tag Stock Code 37 22 236</p> <p>Ameren Crossbore Brochure v4</p>	January 1, 2016	April 1, 2017
<u>BORE 2.04</u>	<p>Boring Across or Near Sewer Lines</p> <p>4. Construction Steps</p> <p>4. H.: Added the stock code for the door hanger.</p> <p>5. Sewer Cleaning Notification</p> <p>5. A.: Revised to that a reflect a new crossbore informational brochure "Caution: Natural Gas and Electric Lines May Unintentionally Intersect Sewer Lines" has replaced the Information Letter Gina Meehan sent out annually.</p> <p>Deleted the informational letter that had previously been mailed to local plumbers, city sewer departments and operators of sewer cleaning businesses.</p>	January 1, 2016	April 1, 2017
BORE 4	<p>Forms and Reference Materials</p> <p>Added:</p> <p>Door Tag Stock Code 37 22 236</p> <p>Ameren Crossbore Brochure v4 - Caution: Natural Gas and Electric Lines May Unintentionally Intersect Sewer Line</p>	January 1, 2016	April 1, 2017
CORR 2.29	<p>Records</p> <p>2. Construction Order Review Processes</p> <p>2. B. (1) (c): Post Construction - As Built - Responsibility Table: Correction: Joe Hermansa for Division 4.</p>	January 1, 2016	April 1, 2017
<u>GLOS</u>	<p>Glossary:</p> <p>Added:</p> <p>Branched Service Line</p> <p>Commercial Service</p> <p>Confirmed Discovery</p>	January 1, 2017	April 1, 2017

UNCONTROLLED IF PRINTED

	<p>Distribution Center Manual Service Line Shut-Off Valve Replaced Service Line Residential Service Service Line Serving a Single Family Residence (SFR) Revised: Distribution System</p>		
<u>INCD 0</u>	<p>Table of Contents INCD 4: Updated Potential Incident Report Form (January 1, 2017)</p>	January 1, 2014	April 1, 2017
<u>INCD 4</u>	<p>Forms and Reference Materials Updated Form 03 - Potential Incident Report Form (January 1, 2017) Added Service interruption to 25 customers or more for 8 hours or more. Updated contact information.</p>	January 1, 2016	April 1, 2017
LEAK 2.03	<p>Leak Investigation Form 4. Outdoor Investigation Documentation 4. B. Perform Subsurface Sampling Revised to: Utilizing an approved leak detection instrument. Replaces Utilizing CGI & Probe Rod. Allows for the use of leak detection equipment to be used to survey the surface for gas migration over gas facilities.</p>	December 1, 2014	April 1, 2017
SERV 2.08	<p>Insertion 4. Dead Insertion Procedures 4. J. Table: Corrected Stock Code Numbers for 1-1/4" x 1/2" and 1-1/4" x 1" Plastic Pipe Protectors. 4. L. Added table of Cold Shrink Gas Pipe Insertion Seals with sizes and stock codes.</p>	January 1, 2016	April 1, 2017
TAPS 2.05	<p>Mueller AUTOPERF Tee Revised Note 2) regarding the limitation of the AutoPerf Tee to match the information in SERV 3.06 and SERV 3.07 the Farm Tap Standards. Revised Note 3) to match information in SERV 3.06 and SERV 3.07 the Farm Tap Standards</p>	January 1, 2016	April 1, 2017

	Removed all of the AutoPerf Tee's limitations based on classification and/or diameter of pipe.		
--	--	--	--

Supersedes: January 1, 2017

CHANGE SUMMARY

January 1, 2017

Change Summary January 1, 2017

Docu- ment	Change Summary	Previ- ous Docu- ment Dated	Current Docu- ment Dated
---------------	----------------	---	-----------------------------------

Throughout the entire Metering section, AIC replaces Ameren Illinois in the previous O&M versions.

OPERATIONAL PROCEDURAL CHANGES

METR 1	<p>1. A.: Added two new terms that are now included in IAC 501, auxiliary and tertiary equipment which are attached to or connected to the meter. These terms have been added to the Glossary.</p> <p>Auxiliary Equipment - Means an integral device attached directly or remotely to a gas meter. The function of auxiliary equipment is to adjust gas meter usage measurements to account for changes in gas temperature or pressure (for example, correctors).</p> <p>Tertiary Equipment - means a device that electronically converts signals from a gas measurement system (meter or auxiliary equipment or both) to a useful form such as flow rate (for example, flow computers and remote monitoring devices (RMD)).</p> <p>1. B.: Added references to meter sizing and regulator sizing tables that are in the Meter Standards section.</p> <p>2. Care and Handling</p> <p>Majority of this original section has been moved to METR 2.01 Gas Meter Handling. There was no reason to duplicate the information since there is a specific section which addresses meter handling and transporting.</p> <p>3. Location</p> <p>3. A.: For new or relocated residential meters, IAC Part 501.110 IAC Part 501.110 states no meter shall be installed indoors unless an outdoor installation is not possible or would make the meter installation financially infeasible. Commercial/Industrial meters can be installed inside designated meter building which is not used for human occupancy.</p> <p>3. B.: If a new or relocated residential meter has to be installed indoors, IAC Part 501 IAC Part 501 requires that it be in a ventilated place and at least three feet from an ignition source or source of heat that could damage the meter.</p> <p>Added the regulator must be located outside of the building or in a separate metering or regulator building.</p>	Janu- ary 1, 2014	Janu- ary 1, 2017
-----------	--	-------------------------	-------------------------

3. C.: Clarified that new or relocated residential meters shall be located immediately adjacent to an outside wall.

3. F.: Clarified that new or relocated meters should be installed in area free of vehicular traffic. If this is not practical, the meter shall be protected by guard posts or railings.

3. G.: Gas meter shall not be installed:

3. G. (1): "In direct contact with soil, concrete or other surfaces that will cause corrosion unless the gas meter is designed for those condition."

Previously, it said gas meter shall not be in direct contact with ground. [IAC Part 501.110](#) IAC Part 501.110 states meter, auxiliary or tertiary equipment shall not be installed in contact with soil or concrete unless the manufacturer designed the equipment for those conditions.

3. G. (2): New, Within three feet of a source of heat which could damage the meter or expose the meter to temperatures that are outside those recommended by the manufacturer. In AIC case that is higher than 140°F or below -40 °F

[IAC Part 501.110](#) IAC Part 501.110 added these prohibited locations and our meter manufacturers provided the temperature limitations.

3. G. (3), (4), (5), (6): Not a major change only moved some wording around.

3. G (10) (a): Specified that it is the service regulator vent, not the meter, which shall not be within three feet of an ignitions source. Added examples of items that are potential sources of ignition. This is consistent with the Residential Meter Set Location Restriction, Exhibit 3 in SERV 1.

3. G. (10) (b): Specified that it is the service regulator vent, not the meter, which shall not be within twelve inches horizontally from specific openings into a house. Added examples of openings into a structure. This is consistent with the Residential Meter Set Location Restriction, Exhibit 3 in SERV 1.

3. G. (10) (c): Added the service regulator shall not be installed where it cannot vent freely to the atmosphere. This is a paraphrase of the PHMSA Part 192.355 language.

3. H. Refusal of Service is a new section based on language in [IAC Part 501.110](#) IAC Part 501.110 that is not in IAC Part 500.

Allows a utility to refuse service to a customer if the metering installation, customer piping, customer equipment is hazardous or in such condition that gas service cannot be safely provided.

Requires the Company to notify the customer of the refusal within five days of the decision to refuse service.

4. Installation

4. A.: Added regulators as part of meter set.

4. B.: Slight rewording and combined a couple of sentences from the previous METR 1. This sentence states the meter set shall be secure, upright, plumb, and level to prevent undue stress on the connecting piping and meter.

4. C.: New item added to specifically state that the residential customer's piping coming through the wall or foundation should 1 inch black iron or a CSST terminal bracket.

4. D.: New item added which states the black iron pipe should be connected to the meter bar or header. This will provide additional support which reduces the stress on the meter set.

Added an exception for areas that need to use flex braided connectors in areas with subsurface subsidence.

4. F.: Clarified that "Only qualified" personnel are authorized to install, relocate, modify, or maintain an Ameren meter set.

4. G.: Replaced "corrector" with "auxiliary and/or tertiary equipment" that are required if a non-temperature compensate meter is installed.

4. H.: New item which states all meters shall have a register or display on the meter or corrector that displays the consumption delivered to the customer and that display must be clearly visible to the customer. This is an [IAC Part 501](#) IAC Part 501 Code requirement. AIC already complies with this.

4. I.: New item, IAC Part 501 Code requires all meters, auxiliary and tertiary equipment to have security seals installed or measures taken to secure AIC equipment to deter unauthorized personnel from tampering. AIC already complies with this.

4. J.: New item, IAC Part 501 Code requires all meter bypass valves be locked closed when not in use. This is already standard practice at AIC.

4. K.: New item, IAC Part 501 Code requires regulators installed on fixed factor meter installation be sealed. Sealing of fixed regulators was already required under METR 2.15 Pressure Factor Metering.

4. N.: Simply replaces "steel pipe" with "metallic pipe/tubing"

5. Regulator Vent Lines - Added Regulator to clarify what vent lines.

5. A.: Simply replaces "steel pipe" with "metallic pipe/tubing"

6. Painting Meter Sets

6. A.: Identified the specific section in CORR 2.03 for the approved paint.

6. C.: Revised those meter set items that are not to be painted; regulator and relief valve vent openings, meter and regulator name plate badges, meter index, electronic correctors or any auxiliary equipment or remote meter reading devices or other tertiary equipment.

Remove stainless steel sensing lines since in some cases they are being painted.

8. Removed Meters

8. B.: Added the reference link to METR 2.01 2. Gas Meter Handling and Transporting.

METR
2.01

Gas Meter Handling

2. Handling and Transporting - Added Transporting

Since [IAC Part 501](#) IAC Part 501 treats auxiliary and tertiary equipment the same as gas meters in the handling and transporting, these two terms have been added where ever there was a reference to gas meters.

2. B. (1) thru (6) were previously listed in METR 1 2. Care and Handling

2. B. (1): Added language from [IAC Part 501.120](#) IAC Part 501.120 that meters that are located in a meter proofing room waiting for testing do not have to be capped nor do the meters waiting to be repaired.

2. C.: Revised to clarify that a removed meter, auxiliary or tertiary equipment must be handled so that the subsequent accuracy test of the equipment at the meter shop is representative of the meter and equipment when they were in service.

AIC Part 501.170 requires removed meters to be checked for accuracy. Removed auxiliary or tertiary equipment must be checked for proper operation and settings.

2. D.: Simply typos, capitalizing the term Sample Lot.

2. E.: New item from [IAC Part 501.120](#) IAC Part 501.120 which requires meters not in service to be stored in a secure, weather protected environment in an upright position. This does not apply to meters being transported in the trucks. This means the meters must be protected from rain and snow.

April
1,
2010

Janu-
ary 1,
2017

METR
2.03

Sample Testing

Majority of the revisions involve updating the language; AIC replaces Ameren Illinois, Administrative Code Part 501 replaces Illinois Commerce Commission, and updating the version designation for the Military Standard 105 D to (ANSI/ASQ Z1.4 2008).

6. Annual Sample Meter Scheduling

Janu-
ary 1,
2011

Janu-
ary 1,
2017

6. D.: New, [IAC Part 501.250](#) IAC Part 501.250 states that all required sample tests be completed by the end of the calendar year in which the tests are due for completion. AIC already follows this practice.

8. Rejected Sample Lots

8. A.: [IAC Part 501.250](#) IAC Part 501.250 requires all meters in a failed meter lots to be removed within 24 months after the current year’s sampling. This is a significant change since under IAC Part 500, all of the meters had to be removed within 12 months after the year’s sampling.

8. B.: Added the failed to rejected lot meters.

METR
2.04

Periodic Testing

Throughout the document AIC replaces Ameren Illinois.

Janu- Janu-
ary 1, ary 1,
2013 2017

2. Periodic Testing of Diaphragm Meters

2. A.: Revised to clearly state that all diaphragm meters that are not in the sample testing program will be tested every 10 years based on the date of the last test. AIC already complies with the 10 year requirement.

2. B.: Diaphragm meters 800 scfh and larger are included in the Periodic Testing program. AIC has moved the 630 scfh meters into the Sample Testing program.

3. Periodic Testing of Rotary Meters

[IAC Part 501.190](#) IAC Part 501.190 greatly expanded this section.

3. A.: Rotary meter must have either a differential test or a meter shop accuracy test performed at least every 60 months based on the date of the last test.

A meter shop accuracy test was added as an alternative to a field differential test. Previously, AIC was required to perform a field differential test at least every 5 years.

3. B.: If the differential test is more than 50% higher than the initial differential test or the manufacturer’s published curves [IAC Part 501.190](#) IAC Part 501.190 stipulates the steps that can be taken. If the differential cannot be returned to be within 50%, AIC has 7 days to clean and retest. If that isn’t successful, AIC has 60 days to replace the rotary meter. Where modifications to the customer’s facilities are required to remove the meter, AIC will replace the meter within 90 days unless AIC and customer agree to a longer period not to exceed 180 days.

3. C.: If AIC documents conditions that prevent AIC from obtaining a differential reading, verification may be delayed until the condition ceases to exist or up to 4 months, whichever is shorter. Documentation must be retained for 3

years of the conditions that prevented verification within the required 60 months.

4. Periodic Testing of Turbine and Ultrasonic Meters

[IAC Part 501](#) IAC Part 501 greatly expanded this section and the accuracy test requirements.

4. B.: Turbine Meter

[IAC Part 501.200](#) IAC Part 501.200 greatly expanded this section.

4. B. (1) All turbine meters, regardless of the metering pressure, must have an accuracy test performed at least every 60 months. The accuracy test pressure must be between 50% of the operating pressure up to 2 times greater than the operating pressure. Dual rotor turbine meters with an external means of verifying meter accuracy may extend the accuracy test to at least every 120 months as long as AIC verifies the meter accuracy at least every 6 months.

Previously, turbine meters operating below 100 psig required a spin test every 12 months and an accuracy test every 5 years. Turbine meters operating at 100 psig or greater required a spin test every 6 months and an accuracy test every 12 months.

4. B. (2): All single rotor turbine meters must have a spin test every 12 months. If the turbine meter is not equipped with external lubrication fittings, a spin test is required every 6 months. A spin test is not required on dual rotor turbine meters that have an external means of verifying rotor health performed at least every 6 months and can demonstrate the rotor meets manufacturer's guidelines.

4. B. (3): Added, See METR 2.13 Turbine Meter Testing for more details.

4. C. Ultrasonic Meter

[IAC Part 501.220](#) IAC Part 501.220 greatly expanded this section.

4. C. (1): Ultrasonic meters must be interrogated every 3 months. Previously, the interrogation was required twice each calendar year.

4. C. (2): The pressure and temperature transmitters shall be verified when the meter is interrogated. Previously, the transmitters had to be calibrated.

4. C. (3): AIC must flow calibrate ultrasonic meters every 120 months unless AIC can demonstrate the meter meets the manufacturing tolerances and AIC conducts an internal inspection of the meter body to ensure the meter has not accumulated deposits or incurred damage that would affect meter's accuracy.

4. C. (4): Added, See METR 2.25 Ultrasonic Meter Testing for more testing details.

5. Periodic Meter Testing Schedule

5. C.: The GTS Supervisor is now responsible for ensuring all listed rotary meters are tested prior to the test due date. Previously, it stated the Gas Metering Supervisor was responsible.

METR
2.06

Prover Accuracy Certification and Verification

Janu- Janu-
ary 1, ary 1,
2011 2017

2. Prover Certification

2. B.: [IAC Part 501.160](#) IAC Part 501.160 requires sonic nozzle provers to be calibrated and certified at least every 12 months. Previously, the provers had to be certified at within 36 months from previous certification.

2. C.: Gas meter testing contractors used to repair or test AIC meters must also provide proof their sonic nozzle prover(s) have been tested and certified at least every 12 months. Previously, the contractors had to provide proof annually that their testing equipment had been certified at within the last 36 months.

3. Reference Meter Verification Tests

3. B.: New: Reference meter verification shall be performed on each transfer prover every 3 months and an AL800 reference meter shall be utilized during the verification test.

[IAC Part 501.160](#) IAC Part 501.160 requirement for transfer provers.

4. Documentation of Reference Meter Verification Tests

4. A.: Updated, the test information is recorded in MMS for each prover and not on the "Weekly Gas Reference Meter Log".

4. B.: The Reference Meter Test Result Report is run from within MMS.

4. C.: The Reference Meter Verification Tests results are to be logged for each prover.

5. Corrective Action

5. A. (1) Grammatical change, ± 0.5% from 100%

5. B. and 5. C.: Grammatical change, Weekly Gas Reference Meter Results Report replaces Weekly Gas Reference Meter Log.

METR
2.12

Rotary Meter Differential Testing

April Janu-
1, ary 1,
2013 2017

1. B.: Grammatical change in third sentence, "can" replaced "will", added "includes" and added "/or".

3. Periodic Test

3. B.: Revised to "In-service rotary meters shall be differential tested at least every 60 months from the last test date...." Previous stated "on or before the five year anniversary from the last test date"

3. C.: Repeat of what is in METR 2.04 3. C. Periodic testing of Rotary Meters. If AIC documents conditions that prevent AIC from obtaining a differential reading, verification may be delayed until the condition ceases to exist or up to 4 months, whichever is shorter. Documentation must be retained for 3 years of the conditions that prevented verification within the required 60 months. [IAC Part 501.190](#) IAC Part 501.190 language.

3. D.: In lieu of a differential test, AIC may complete an accuracy test. The average accuracy is determined by averaging the accuracy of the check and open flow rates. [IAC Part 501.190](#) IAC Part 501.190 language.

4. Equipment

4. D.: Added "or timing device" to a clock or stop watch that are required to time the meter.

4. F.: Added "is an acceptable reference" for the manufacturer's factory differential pressure curves.

5. Differential Test

5. D.: Grammatical, added "if" to "determine if the minimum test flow requirement is met."

7. Follow-up Action

7. B. Grammatical, "receive" replaced "required", "The meter may receive corrective maintenance in the field to reduce the differential pressure to an acceptable level..."

7. C.: Repeat of what is in METR 2.04 3. B. Periodic testing of Rotary Meters. If the differential pressure can't be reduced to less than 50% increase over the original value, the meter must be replaced within 60 days. If the meter is of sufficient size that portions of the customer's structure requires modification to remove the meter, AIC will replace the meter within 90 days unless AIC and Customer agree to a longer period not to exceed 180 days.

METR
2.13

Turbine Meter Testing

[IAC Part 501](#) IAC Part 501 expanded the testing requirements

Janu- Janu-
ary 1, ary 1,
2013 2017

2. Testing Requirements

Repeat of what is in METR 2.04 4. B. (2) Periodic testing of Turbine Meters

2. A.: Turbine meters with external lubrication fittings now have to be spin tested at least every 12 months and if necessary lubricated.

Previously, a turbine could be lubricated in lieu of a spin test.

2. B.: Turbine meters without external lubrication fittings or external means of verifying the operation of the meter require a spin test every 6 months.

Previously, turbine meter operating below 100 psig had to be lubricated or spin tested each year. Turbine meter operating at 100 psig or greater had to be lubricated or spin tested every 6 months.

2. C.: A spin test is not required on dual rotor turbine meters if the meter has an external means of verifying rotor health and the rotor health is verified at least every 6 months and the rotor performance meets the manufacturer's guidelines. AIC Part 501.200 language.

2. D.: Single rotor turbine meters shall be accuracy tested at least every 60 months. This section also includes detailed testing criteria required by AIC Part 501.200.

2. E.: Dual rotor turbine meter with external means of verifying meter accuracy may extend the accuracy test to at least 120 months if the meter accuracy is verified at least every 6 months and meter's performance meets the manufacturer's guideline. AIC Part 501.200 language.

3. Test Equipment

3. A.: Added "or timing device" to a clock or stop watch that are required to time the meter.

3. C.: [IAC Part 501](#) IAC Part 501 revised the flow rate of the prover equipment to between 10% and 105% rated capacity required for the accuracy test. Previously was 20% to 80%.

7. Accuracy Test

7. A. (3): Revised flow rate requirements to between 10% and 105% rated capacity. Previously was 20% to 80%.

METR
2.14

Electronic Corrector Inspection

1. A.: Added, That an electronic corrector must be used where the elevated metering pressure is greater than 15 psig. However, Company use gas meters that operating above 15 psig on January 1, 2017 are grandfathered from requiring an electronic corrector. [IAC Part 501](#) IAC Part 501 only allows fixed factor for metering pressures 15 psig or less except for Company use meters in place on January 1, 2017.

1. C. Replaced "verify the accuracy" with "verify proper operations"

2. Electronic Corrector Inspection Schedule

2. A.: Revised, "Each electronic corrector installed at a customer meter installation shall be inspected and verified for proper operation at least every sixty (60) months. [IAC Part](#)

De-
cem-
ber 1,
2014

Janu-
ary 1,
2017

501.170 IAC Part 501.170 made corrector inspection mandatory.

2. B.: Position title update to Superintendent from Supervisor Gas Metering.

3. Pressure Verification

3. A.: The pressure transducer will be verified for proper operation by comparing the electronic corrector pressure reading to a test gauge. The difference in the readings must be within $\pm 1.0\%$ Refer to the pressure verification equation contained in the next section of this procedure that calculates the acceptable verification tolerance for each metering pressure. The pressure transducer shall be verified at zero and flowing pressure.

IAC Part 501.310 IAC Part 501.310 requires the accuracy to be within $\pm 1.0\%$ where previously there was a pressure range table with acceptable accuracy ranges. The table had to be replaced with a formula since every pressure would have a different acceptable range.

3. C.: Replaced "verify the accuracy" with "verify proper operations"

4. Pressure Verification Equation - Replaces the Allowance Variance Table. Since the verification reading has to be within $\pm 1.0\%$ each pressure value will have different \pm psig value. The metering pressure multiplied by 1.0% will give you the allowable variance.

5. Temperature Verification

5. A., 5. B. and 5. C. : Replaced "verify the accuracy" with "verified for proper operations"

5. A.: The difference between the Versitest reading the electronic corrector reading must be with ± 2.5 degrees Fahrenheit. The temperature shall be verified at 32 ° F and 75 ° F or flowing gas temperature. IAC Part 501.300IAC Part 501.300 requirements. Previously the temperature difference was ± 5 degrees.

6. Maintenance Activities

6. B.: Corrector Maintenance

6. B. (4): Corrector Date Set, excepted the Mini-P since it does not have a date feature that can be verified

6. B. (5): Corrector Time Set, excepted the Mini-P since does not have a time feature that can be verified.

7. Atmospheric Corrosion Inspection Follow-up

7. B.: Update the reference link to CORR 1 13. Atmospheric Corrosion.

8. Records

8. D.: The inspection information shall be maintained for 10 years, [IAC Part 501.300](#) IAC Part 501.300 requires 10 year where previous it was only 3 years.

METR
2.15

Elevated Metering Pressure

Octo- Janu-
ber 1, ary 1,
2011 2017

2. Elevated Metering Pressure Considerations

2. A. and 2. B.: Grammatical, AIC replaced Ameren Illinois

2. D.: New, The Division Gas Engineer should select the lowest possible metering pressure based on the customer's equipment requirements and a typical interior piping design. In addition, the meter set piping configuration should be designed to prevent excessive pressure drop or pressure variation at the meter outlet.

3. Pressure Factor Metering

3. B.: Revised to emphasize that Pressure Factor Metering can only be used where the metering pressure is 15 psig or less. Added an exception for the Company use meters that are metering above 15 psig on January 1, 2017. [IAC Part 501.150](#) IAC Part 501.150 restricts fixed factor meter to meters operating at 15 psig or less.

3. E.: The regulator selected for pressure factor metering must be capable of holding a constant outlet pressure to within $\pm 1.0\%$ of absolute billing pressure. [IAC Part 501.150](#) IAC Part 501.150 requirement for fixed factor metering. GTE says Ameren's regulators meet this requirement. Previously, the regulator had to hold the outlet pressure within $\pm 1/4$ to $1/2$ psig under anticipated load.

3. E.: Added the metal tag showing the metering pressure can be installed in a visible location near the regulator or the meter index. Previously, the tag was to be located near the meter index.

3. F. The requirement to use a calibrating gauge for setting and verifying meter pressure on all new and existing pressure factor meter sets replaced the use of Test gauges. [IAC Part 501](#) IAC Part 501 requires the use of a Portable Standard which is a calibrating gauge for setting and verifying pressures.

3. H.: New, The gas metering pressure shall be adjusted if the "As Found" pressure is found to be greater than ± 0.25 psig from the expected pressure.

Previously, this variance was ± 0.5 psig but [IAC Part 501.150](#) IAC Part 501.150 requires the regulator to hold outlet pressure to $\pm 1.0\%$ of absolute billing pressure which is less than ± 0.5 psig. The Committee agreed on ± 0.25 psig as acceptable.

5. Electronic Correctors

5. B. Added Gas Tech Engineer who along with Division Gas Engineer should coordinate with IL Metering and Projects in reviewing and specifying meter and regulating equipment when an electronic corrector is needed.

5. C.: Wording revised to emphasize that an electronic corrector shall be selected when elevated metering pressure is greater than 15 psig.

5. E.: Revised to require Gas Tech Engineering or IL Metering and Projects' approval for installation requiring elevated metering pressure greater than 15 psig. Since a corrector will be required for elevated pressures greater than 15 psig, additional approval is required.

5. F. New, Any meter with metering pressure of 175 psig or greater shall be approved by Gas Tech Engineering and by IL Metering and Projects.

Important to ensure these installations have been designed correctly and that they have no adverse effect on the gas system.

6. Records

6 B.: Replace "annual verification" with "field verification"

METR
2.16

Gas Meter Data Sheet

- 4. C. (1) (a) 2: AIC replaced Ameren Illinois
- 4. C. (1) (c) 21: "calibrating gauge" replaced "test gauge"
- 4. C. (1) (d) 28: "calibrating gauge" replaced "test gauge"
- 4. C. (2) (a) 63: AIC replaced Ameren Illinois
- 4. C. (2) (c) 75: "calibrating gauge" replaced "test gauge"
- 4. C. (2) (d) 81: "calibrating gauge" replaced "test gauge"

Janu-
ary 1,
2016 Janu-
ary 1,
2017

METR
2.19

Pressure Factor Verification

2. Verification Information

2. A.: Added GTS as another group that will be provided a list of gas meters with billing constant greater than 1.

2. D.: New, Investigation orders will be created in OAS for each premise with a factor billed elevated meter pressure.

3. Pressure Factor Verification

3. B.: [IAC Part 501](#) IAC Part 501 requires the metering pressure be verified with calibrating gauge (portable standard) rather than a test gauge. IAC 501 requires the flow rate to be less than 90% of the meter's capacity at the designated fixed factor metering pressure.

A Portable Standard (calibrating gauge) is required when setting and verifying equipment associated with correcting meter's output.

De-
cem-
ber 1,
2014 Janu-
ary 1,
2017

3. C.: [IAC Part 501.150](#) IAC Part 501.150 requires the metering pressure verification at least every 36 months. If conditions at the meter prevent this verification are documented, verification can be delayed up to 4 months.

3. E.: [IAC Part 501.150](#) IAC Part 501.150 allows residential meters that have a fixed factor meter pressure of 5 psig or less and a rated capacity under 700 cfh to be exempt from pressure factor verification process.

Previously, residential customer meters with a fixed factor of 2 psig were exempt from this verification process.

3. F.: New, [IAC Part 501](#) IAC Part 501 has added non-residential meters with a 2 psig or less metering pressure and a rated capacity under 700 cfh do not have to be included in the pressure factor verification process.

Previously these meters had to have the pressure verified.

7. Corrosion Control Inspection Follow-up

7. B.: Updated the reference link to CORR 1 13. Atmospheric Corrosion.

METR
2.20

Meter Header Inspection

2. Inspections/Maintenance When A Meter Set is Not Disassembled

2. A. (6): Added "spring cap" as another item that needs to be checked.

QA Consultant pointed out this item was not included and it is important that this cap be in place on the regulator to discourage unauthorized personnel from adjusting the pressure.

2. B.: Added discrepancies should be documented in Click-Mobile when they are not immediately repaired.

QA Consultant felt needed to indicate how to document.

3. Inspections/Maintenance When A Meter Is Installed/ Changed or Set is Disassembled

3. A. (7): Added "spring cap" as another item that needs to be checked.

3. B.: For consistency, copied 2. B. language on how discrepancies should be handled when they are not immediately repaired.

April
1,
2013

Janu-
ary 1,
2017

METR
2.22

Pressure Gauges

AIC replaced Ameren Illinois in the document

1. D.: New, Pressure gauges used during the construction and maintenance process which verifies or qualifies MAOP are addressed in PTST 1 3. Test Recording Methods.

Janu-
ary 1,
2016

Janu-
ary 1,
2017

2. Ameren Illinois Company (AIC) Pressure Gauge Definitions

Deleted the definitions for Industrial/Commercial Gauge and Process Gauge since these gauges will no longer be used in metering operations, maintenance, inspections or verifications.

2. B.: Calibrating Gauge is considered a "Portable Standard" which is used for field verification and calibrations as now required under [IAC Part 501](#) IAC Part 501.

2. C.: New, is the definition of Portable Standards - means instruments that utilities use in the field or the meter shop to test the accuracy of auxiliary and tertiary equipment, transmitters, and other equipment associated with correcting a meter's output

2. D.: New, is the definition of Reference Standard - means instruments that utilities use only for verifying the accuracy of portable standards, and whose accuracy is traceable back to the national standard maintained by the National Institute of Standards and Technology (NIST) or its successor.

Notice: Reference Standards are for use in a shop environment only and never taken to the field.

These definitions were copied from [IAC Part 501](#) IAC Part 501 and are included in the Glossary.

4. Uses of Calibrating Gauges (Portable Standard) - New Section

(1) Establishing the regulator set pressure for all new customers metered at an elevated pressure (2 psig or greater).

(2) Performing the annual metering pressure verification for all commercial customers metered at an elevated pressure.

(3) Adjusting the regulator operating pressure for all customers metered at an elevated pressure

(4) Verifying the proper operation of electronic correctors, transmitters, other auxiliary and tertiary equipment connected to a meter and other equipment associated with correcting a meter's output.

The first 3 items were previously under Uses of Test Gauges. [IAC Part 501](#) IAC Part 501 requires the use of a portable standard when setting, verifying or adjusting equipment associated with correcting meter's output.

5. Storage and Transportation of Gauges

5. A. & 5. B.: Added "calibrating gauge" that are to be handled in the same manner as test gauges.

6. Verification and Calibration

6. A. (2): Test gauge accuracy is to be verified at zero scale in addition to half scale and full scale.

6. A. (3):Grammatical only, "within it's given tolerance" replaced "within a given tolerance".

6. B. Calibrating Gauge

6. B. (1): [IAC Part 501.160](#) IAC Part 501.160 requires calibrating gauge accuracy verification at least every 12 months.

Previously these gauges were calibrated once each calendar year not to exceed 15 months. [IAC Part 501](#)IAC Part 501 does not provide a 3 month compliance window.

6. B. (2): Removed the listing of the locations where the calibrating gauge could be sent for calibration. GTS personnel will be performing the calibration and those who have calibrating gauges know where and who to send the gauges.

6. C.: New, The reference standard shall be certified at least every 36 months or by the certification due date.

[IAC Part 501.160](#) IAC Part 501.160 requires Reference Standards to be certified at least every 36 months. However, some of the certifications are only good for 1 year.

7. Recordkeeping

Added "reference standard" to the list of gauges that have to have their verification and calibration history maintained in Maximo.

METR
2.24

Replacement of Large Volume Diaphragm Meters

AIC replaced Ameren Illinois throughout the document

Janu- Janu-
ary 1, ary 1,
2014 2017

5. Additional Checks

5. A. (5): Added the reference link to METR 2.20 5. Meter Header Inspection, Banded Regulators

6. Meter Being Transported or Moved

6. A.: Added reference link to METR 2.01 2. Handling and Transporting.

8. Changing Correcting Devices

8. A.: Added, The transferred correcting device shall be inspected to verify proper operations within 60 days after the meter exchange.

[IAC Part 501.290](#) IAC Part 501.290 requires the corrector to be checked for proper operation following the transfer. The committee deemed within 60 days of the transfer as a reasonable time.

13 Reporting

13. B.: Added reference link METR 2.16 for the Gas Meter Data Sheet

METR
2.25

Ultrasonic Meter Testing

Janu-
ary 1,
2016

Janu-
ary 1,
2017

AIC replaced Ameren Illinois in the document

1. A.: Grammatical, spelled out ultrasonic meters for (USM's)

1. B.: Grammatical, added the word "utilizes"

2. Ultrasonic Meter Inspection Schedule

2. A.: In addition to meters installed at customer locations, ultrasonic meters installed at the AIC storage fields now require inspection and interrogation at least every 3 months.

Added, At least 2 of the quarterly maintenance reports in a calendar year must be with gas flowing through the meter.

This is an ICC's expectation that there be flow through the meter during 2 of the inspections.

2. C.: Added a listing of the items that are required for an inspection.

This listing came from [IAC Part 501.220](#) IAC Part 501.220.

2. G.: New item that address multi-path ultrasonic meters. These meters are to flow calibrated at least every 120 months. If the periodic inspection documentation demonstrates the meter meets the manufacturing tolerances and the AIC conducts an internal inspection of the meter body at least every 120 months to ensure there is not an accumulation of internal deposits or other damage, AIC may forego the flow calibration requirement. This [IAC Part 501.220](#) language.

4. Chromatograph Operational Check

4. A.: The gas chromatography has to be programmed such that the calibration of the unit is being performed at a minimum programmed cycle of at least once every 24 hours. [IAC Part 501.320](#) IAC Part 501.320 revised, previously this was performed once per week.

For gas chromatograph used in the gas storage field, if the field in not injecting or withdrawing, the calibration can be suspended until the facility resumes injecting or withdrawing.

4. C.: Revised to, Verify at least every three (3) months that the gas component un-normalized mole % variance is within $\pm 1.5\%$ of the gas contained within the calibration gas cylinder and that the values are being received at the meter and the on-site flow computer.

4. E.: New, The calibrated gas cylinder shall be certified or replaced at least every thirty six (36) months.

The above revisions are [IAC Part 501.320](#) IAC Part 501.320 requirements.

5. Inspection Records

UNCONTROLLED IF PRINTED

5. E.: New [IAC Part 501](#)IAC Part 501 requirement; The most recent five (5) years of inspection records shall be maintained. Documents shall also be maintained for a multi-path ultrasonic meter's most recent accuracy test, prior accuracy test and the dates of any other accuracy test that occurred during the prior ten (10) years.

METR
2.27

Electronic Corrector Installation Verification - Added the word Installation

January 1,
2016 January 1,
2017

1. A.: Clarification that an electronic corrector must be selected in instances where the elevated metering pressure is greater than 15 psig.

[IAC Part 501.150](#) IAC Part 501.150 restricts fixed factor metering to 15 psig or less.

1. C.: Grammatical, added the word "activities".

2. Electronic Corrector Inspection Schedule

2. A.: Changed the inspection schedule to 60 days from 90 days following the installation of a new or an exchanged corrector at a customer's premise.

[IAC Part 501.290](#) IAC Part 501.290 requires that following attachment of auxiliary equipment to a meter, the proper operation of the auxiliary equipment must be verified. The committee deemed within 60 days of installation as a reasonable time.

2. D.: New; All in-service electronic correctors shall be verified for proper operations at least every sixty (60) months

[IAC Part 501.300](#)IAC Part 501.300 requires corrector operation be verified following installation. The committee deemed within 60 days of installation as a reasonable time.

3. Device Programming Verification

3. A.: Grammatical, added a "s" to Codes

5. Corrector Edit Calculation

5. A.: Grammatical revisions in wording.

7. Records

7. D.: The verification records must be maintained for 10 years. [IAC Part 501.300](#)IAC Part 501.300 change previously the records were only maintained for 3 years.

METR
2.28

Customer Request Test - New Section

New January 1,
2017

This section was added in order to comply with [IAC Part 501.280](#)IAC Part 501.280

This procedure was established for processing "Customer Requested Test" on a gas meter. It outlines the process to assure proper notification of gas meter accuracy test results to all parties or their stated representatives.

2. Definition

A Customer Requested Test gas meter is any meter removed from service as a result of a customer compliant and requesting an accuracy test. The same requirements apply to an accuracy test requested by an Alternative Gas Supplier or by the ICC.

3. AIC Requirements

3. A.: The accuracy testing of a customer requested test meter shall be completed within 45 days after receiving the customer’s request.

4. Reporting Customer Requested Gas Meters

This section contains detailed procedures on how the request order is generated, how the meter is to be handled and delivered to the meter shop (within 5 days of the request), notification to the customer of the testing schedule (within 15 days of entry into MMS), possible customer cost and notifying customer of test results within 5 days after completing the test. This section also provides the procedures for a Commission Referee Test.

SERV
1

Requirements

Janu- Janu-
ary 1, ary 1,
2016 2017

5. Location

5. D.: Clarification that this applies to residential meter riser locations and that the location of the riser should take into account public safety, sources of ignition, and air intake into buildings as they relate to the meter set.

5. E.: Provides typical location to avoid and is divided into the location of the regulator vent and of the meter set. The prohibited locations are consistent with those listed in METR 1 3. H. Location

5. F.: New and is a repeat of the [IAC Part 501](#) IAC Part 501 that states gas meters shall not be installed indoors unless outdoor installation is not possible or would make the meter installation financially infeasible.

[IAC Part 501.110](#) IAC Part 501.110

5. (2): Added a reference link to SERV 2.08 4. Q. Insertion, Dead Insertion Procedures

5. G.: Added "for the appropriate meter set standard" following the reference link to SERV 3._ _.

5. I.: Updated the location of a farm tap to be consistent with SERV 2.03 3. Farm Tap Installation, Location which was revised in the January 1, 2016 Update. The farm tap is to be located above ground and on private property.

9. Pressure Testing

9. E.: Updated the reference link to PTST 1 5. Testing.

CORRECTIONS, UPDATES & NEW MATERIALS

<u>GLOS</u>	Glossary Added: Air Intake Auxiliary Equipment Calibrating Gauge Portable Standard Reference Standard Tertiary Equipment Revised: Gas Operations and Services to be consistent with Forward Regulator Station - deleted delivery station	Janu- ary 1, 2016	Janu- ary 1, 2017
METR 0	Table of Contents METR 1: 5. Regulator Vent Lines replaces Vent Lines METR 2.01: 2. Handling and Transporting replaces Handling METR 2.07: Added Bell Provers are not currently used at Ameren Illinois METR 2.14: 4. Pressure Verification Equation replaces Accuracy Verification Table METR 2.21 Pipeline Meter and Chromatograph Calibrations - Removed January 1, 2017. METR 2.22: 2. Ameren Illinois Company (AIC) Pressure Gauge Definition replaces Ameren Illinois Pressure Gauge Definition METR 2.22: 4. Inserted Use of Calibrating Gauges and deleted 5. Approved Test Gauges METR 2.23: 4. Added Currently not used at AIC next to Mileage Testing Program METR 2.27: Electronic Corrector Installation Verification re- places Electronic Corrector Verification METR 2.28 Customer Requested Test is a new section added to the O&M METR 4: Forms - Updated Form 01 Electronic Corrector Inspec- tion Form (January 1, 2017)	Janu- ary 1, 2016	Janu- ary 1, 2017
METR 2.02	Exchange of Obsolete Meters 1. A.: AIC replaces Ameren Illinois	Janu- ary 1, 2011	Janu- ary 1, 2017

UNCONTROLLED IF PRINTED

METR 2.05	Mileage Testing 1. C.: Added "This testing method is not currently being utilized at AIC."	January 1, 2011	January 1, 2017
METR 2.07	Bell Prover Testing 1. C.: Bell provers are not currently utilized at AIC for testing gas meters.	January 1, 2013	January 1, 2017
METR 2.08	Transfer Prover Testing Corrected the Check Flow Rate and Open Flow Rate for the 80B, 250B, and 500B meter sizes. 5. Adjust Testing 5. A.: AIC replaces Ameren Illinois	January 1, 2011	January 1, 2017
METR 2.09	Gas Meter Retirement 2. Criterial for Meter Retirement 2. A. (4): Grammatical, "meter" replaced "meters"	April 1, 2010	January 1, 2017
METR 2.11	Contract Meter Repair AIC replaced Ameren Illinois throughout the document 3. Diaphragm Meters 3. C. and 3. E.: Added "OSB" that can be used as separators when shipping meters.	January 1, 2013	January 1, 2017
METR 2.17	Gas Meter Data Verification 1. A.: AIC replaces Ameren Illinois 2. Gas Meter Data Sheet 2. A.: Moved the reference to METR 2.16 Gas Meter Data Sheet from 2. C. 4. Gas Metering Review WFM 4. C.: Added GTS supervision in addition to Division supervision who must investigate discrepancies between the Gas Meter Data Sheet and CSS. 5. Gas Meter Multiplier Changed WFM 5. B.: Added GTS supervisor in addition to Division supervisor who will receive a Miscellaneous WFM that identifies needed corrective action.	January 1, 2011	January 1, 2017
METR 2.18	Gas Correcting Edits 1. C.: AIC replaces Ameren Illinois 6. Follow-up Actions	January 1, 2011	January 1, 2017

6. C. and 6. D.: Gas Tech Services replaced Gas Operations and Services.

METR 2.21	Pipeline Meter and Chromatograph Calibrations Removed January 1, 2017	Janu- ary 1, 2011	Janu- ary 1, 2017
METR 2.23	Gas Meter Exchange AIC replaced Ameren Illinois throughout the document 3. Periodic Testing Program 3. A.: Changed the smallest size meter for the periodic testing program to a 675 cfh rated meter from the previous 630 size which is now in the Sample Testing Program. 4. Sample Testing Program 4. A.: Revised the wording, AIC will provide notification to the Illinois Commerce Commission Staff of the intention to utilize Sample testing. Under IAC Part 501 IAC Part 501, Utilities only have to notify the ICC of their intention. An authorization is no longer required.	Janu- ary 1, 2016	Janu- ary 1, 2017
METR 2.26	New Meter Testing AIC replaced Ameren Illinois in this document 3. Sample Testing New Diaphragm Meters 3. A.: Updated testing reference documents (ANSI/ASQZ1.4-2008) and Inspection Level II 5. Test New Diaphragm Meters 5. A.: The randomly selected meters have to be tempered in the proofing room for a minimum of 12 hours. Previously, they were to be tempered a minimum of 24 hours. 5. B.: Since AIC does not utilize bell provers, language was revised to, test the meters with the appropriate prover testing equipment. 7. New Rotary and Turbine Gas Meters 7. A. Revised to: Each new rotary and turbine meter may be sample tested following the same procedures as those for diaphragm meters. Depending on the quantity of rotary or turbine meters received, all of the meters may require each meter to be individually tested.	Janu- ary 1, 2013	Janu- ary 1, 2017
METR 3.07	Regulator Sizing - Alternate Approved 2. 7 Inches W.C. Delivery Pressure Removed all of 3/4" x 1" American 1813C and the 1" x 1" America 1813C. The American regulators were moved to METR 3.03 in the September 1, 2016 O&M Update.	Janu- ary 1, 2016	Janu- ary 1, 2017

3. 2 PSIG Delivery Pressure

Removed all of 3/4" x 1" American 1813C and a 1" x 1" America 1813C with 3/16 orifice. The American regulators were moved to METR 3.04 in the September 1, 2016 O&M Update.

REFERENCE MATERIALS

METR 4	Forms and Reference Materials Forms: Updated Form 01 Electronic Corrector Inspection Form (January 1, 2017): Added three additional entries; Address in addition to Town, Meter index Reading under Meter and Corrector Number under Corrector	Janu- ary 1, 2012	Janu- ary 1, 2017
-----------	---	-------------------------	-------------------------

Supersedes: September 1, 2016

CHANGE SUMMARY

September 1, 2016

Change Summary September 1, 2016

Docu- ment	Change Summary	Previ- ous Docu- ment Dated	Current Docu- ment Dated
PROCEDURAL CHANGES			
<p>PRES 2.03</p>	<p>Potential Over Pressurization or Service Interruption</p> <p>4. Activities Requiring an Operational Checklist</p> <p>4. C.: New: "When multiple tie-ins / cut-offs are required for system maintenance or replacement, Gas Engineering shall develop a written sequence of operations to ensure actions taken will not affect system supply. Gas Engineering should review the construction sequence with the Gas Supervisor and the Construction Inspector where applicable. If the scope of the field work changes, the plan should be modified and approved by Gas Engineering."</p> <p>Following an investigation of an unplanned outage during a replacement project AIC developed these new procedures to minimize the chances for unplanned service interruptions when making multiple tie-ins or cut-offs.</p>	<p>Octo- ber 1, 2011</p>	<p>Sep- tem- ber 1, 2016</p>
<p>PTST 1</p>	<p>Pressure Testing Requirements</p> <p>1. A.: Revised to match Part 192 language in that pressure testing is performed to identify "hazardous leaks".</p> <p>1. D.: New, "Pre-tested can be used for replacement, relocation or repair where post installation testing is not practical. Pre-tested pipe shall be tested, at a minimum, to meet the Design MAOP for the location it is being installed."</p> <p>Clarification that pre-tested pipe can be used in those instances where post installation testing is not practical.</p> <p>1. J.: Added a listing of the types of projects which Gas Tech Engineering is responsible for reviewing testing requirements.</p> <p>1. J. (1) All steel gas main/facility projects with Design MAOP greater than 60 psig which includes transmission or high pressure distribution lines or facilities located outside of the Gas Storage Field or compressor plants.</p> <p>1. I. (2): Steel or PE service lines that are two (2) inch and larger that have a Design MAOP greater than 60 psig.</p> <p>1. I. (3): All large meter sets with connected loads greater than 10,000 CFH and/or inlet pressure greater than 60 psig.</p> <p>1. I. (4): All regulator/flow control stations excluding service farm taps less than two (2) inch nominal diameter,</p>	<p>Janu- ary 1, 2016</p>	<p>Sep- tem- ber 1, 2016</p>

odorizer stations, valve stations and any other facility with Design MAOP greater than 60 psig.

1. K.: Added Gas Storage Engineering is responsible for reviewing the testing requirements on all gas facilities located within gas storage fields and compressor plants.

1. L. Added a listing of the types of projects DDC/PDC or Division Engineering are responsible for reviewing test requirements.

1. L. (1): PE mains with Design MAOP of 100 psig or less.

1. L. (2): Steel mains with Design MAOP 60 psig or less.

1. L. (3): PE and steel service lines with Design MAOP 100 psig or less.

1. L. (4): PE and steel service lines two (2) and larger that have a Design MAOP greater than 60 psig should also be reviewed by Gas Tech Engineering.

1. L. (5): High pressure distribution farm tap services less than two (2) inch nominal diameter.

The delineation of responsibilities is being included to eliminate the confusion on which group, GTE or DDC/PDC, handles which type of project.

1. M.: New, "Emergency project(s) or maintenance project(s) on steel main(s) and service(s) with Design MAOP 100 psig or less, testing requirements may be specified by Division Engineering."

Allows Division Engineering to handle steel projects where Design MAOP is 100 psig or less. This eliminates the need to contact Gas Tech Engineering for testing requirements for steel mains and services with Design MAOP of 100 psig or less. PE mains and service with Design MAOP of 100 psig already falls under Division Engineering.

3. Testing Recording Methods

3. C.: Revised when the verification check on process gauge(s) to "annually, not to exceed 15 months" from "annually during 1st quarter". New process gauge(s) placed into service, the accuracy does not have to be verified until the following year.

Gas Superintendents wanted more flexibility and not want to be tied down to the first quarter.

4. Design MAOP

4. B.: Added Division Gas Engineer and Gas Storage Engineering as another group besides Gas Tech Engineering that will designate specific Design MAOP for systems to be operated over 60 psig.

4. D.: Removed the need to contact Gas Tech Engineering if the maximum test pressure is exceeded on system over 60 psig.

5. Testing

5. A.: New: "The actual procedures for performing leak and strength tests along with the methods for performing these tests are contained in the appropriate section shown on PTST 0, Table of Contents.

5. B. (1) thru (7): Added a listing of the test pressure and test duration requirement tables so an individual would know which table applied to their specific project. The pressure testing tables that were previously shown under 5. B. (1) thru (7) have been removed from this section of the O&M.

Each table is in its own section which allows for printing only the testing requirements for a specific type of project.

5. F.: Inserted a new item that addresses the testing of short segments of pipe 2 inch nominal diameter and larger. These short segments of pipe are to be tested in accordance with Table PTST 1 5. E. Fabricated Unit/Assembly, Short Sections of Pipe.

5. G.: New item that addresses the testing requirement for smaller than 2 inch fittings, typically attached to pipe for use as gauge taps, pressure taps, odorant taps, purge points, control line taps. These types of fittings are to be tested in accordance with Table PTST 1 5. A Service Lines - Less than 2" Diameter, Plastic or Steel.

Address testing of small fittings attached to the pipe.

5. H.: New item "Maximum test pressure on steel pipe with Design MAOP of 100 psig or greater should not exceed that designated by Gas Tech Engineering or Gas Storage Engineering."

To avoid overstressing the pipe, GTE or GSE will specify the maximum test pressure.

5. I.: New item "Farm tap on gas pressure system with a Design MAOP greater than 1000 psig shall be designed or reviewed by Gas Tech Engineering (GTE)."

The Farm Tap Standards only go to 1000 psig and there are a few systems with Design MAOP of greater than 1000 psig. Farm Tap off of these systems must be designed by Gas Tech Engineering or Storage Engineering.

5. J.: New item "Pressure containing facilities similar to a farm tap located within gas storage fields and compressor plants shall be designed by Gas Storage Engineer (GSE)."

7. Tie-In Joints

7. B.: Added leak detection instrument can be used to check for leaks if natural gas is the test medium.

8. A Component Other Than Pipe Being Replaced or Added to Pipeline

8. A.: Expanded this item to address testing requirements for a component attached to pipe with different Design MAOP.

A. (1): Components attached to pipeline with Design MAOP 100 psig or less has a minimum test pressure of 100 psig.

A. (2): Components attached to pipeline with Design MAOP greater than 100 psig has a minimum test pressure of 100 psig with a maximum not to exceed the operating pressure of the pipeline, if that pressure is greater than 100 psig.

A. (3): If the component is similar to a cap, valve, elbow, etc., the connection will be tested at the operating pressure of the pipeline.

A. (4): Is an exception for full encirclement split sleeve installed on for a non-leak repair which only requires a visual inspection of the weld.

8. B.: Added leak detection instrument can be used to check for leaks if natural gas is the test medium.

8. C. (2) (a): Added "sav-a-valve nipple" to list of weld fitting examples.

8. E.: New item that addresses testing of instrument, control, or sampling lines. "All mechanically connected instrument, control, and sampling lines shall be rated for the maximum service pressure of the pipe or equipment to which it is attached and shall be checked for leaks at the current operating pressure."

Clarification on testing control or sampling lines which are associated with facilities such as regulator stations, meter sets, odorizers, etc.

9. Test Record

9. A. (1): Revised Gas Leak & Strength Test Stamp, added "Device Serial Number or ID" line.

This was added to meet the requirements in PTST 2.01 and 2.01 for testing information that is required to be recorded. This ties the test record to a specific recording device, gauge or recorder.

9. A. (1) (a): New, "Changes may be made to this test stamp between O&M Updates, so the test stamp on the plans may be different than the one shown above. There is currently a Records Management Committee working on a new Leak Test Record for use by the Distribution Design Centers and Field Operations. There will be a period of time in 2016

where either the above Stamp/Form or the new Leak Test Record will be acceptable."

Work is currently underway to develop new forms for recording pressure tests and as soon as these new forms have been approved, printed and distributed their use will be acceptable.

9. A. (1) (b): New, "When leak detection fluid is used to check for leaks other than Tie-In Joints. Write in "soap test" for the Actual Duration."

Provides direction on how to record soap test.

9. A. (2) Added Gas Storage Engineering as another group that will use the Leak & Strength Test Record. Revised the Leak & Strength Test Record, removed (8 Hours or Longer, Requires Chart).

A. (2) (b): New, "Changes may be made to this test record form between O&M Updates, so the test record form on or attached to plans may be different than the one shown above. There is currently a Records Management Committee working on a new Leak & Strength Test Record for use by the Gas Tech Engineering, Gas Storage Engineering and Field Operations. There will be a period of time in 2016 where either the above Test Record or the new Leak & Strength Test Record will be acceptable."

Work is currently underway to develop new forms for recording pressure tests and as soon as these new forms have been approved, printed and distributed their use will be acceptable.

9. A. (2) (c): New, "When leak detection fluid is used to check for leaks other than Tie-In Welds, write in "soap test" for the Leak Test Beginning Time."

Provides direction on how to record soap test.

9. B.: New item that addresses recording service line testing. "Gas service line test records are recorded on the Gas Service Card within ClickMobile."

Clarifies that service line test records are recorded electronically within ClickMobile and not on one of the test records shown in this section.

9. C.: New item that addresses recording test of meter set piping. "Leak testing on meter set piping shall be recorded on the meter set plans test stamp."

The service line testing in ClickMobile does not include the testing of meter sets. Recording of this testing should be recorded on one of the test records shown in this section and placed on or attached to the meter set plans.

9. D.: New item that addresses recording pre-tested pipe test. "Test record for pre-tested pipe shall be either transferred to the appropriate test stamp/test record or a copy

of the original test record placed in the As - Built construction file.

Addresses documenting the test performed on pre-tested pipe which verifies the pre-tested pipe meets or exceeds the requirement for the application.

PTST 1.01	<p>Test Pressure and Duration Requirement Tables</p> <p>Tables are shown below.</p>	(new)	Sep-tem-ber 1, 2016
PTST 1 TABLE A.	<p>SERVICE LINES - LESS THAN 2" DIAMETER; PLASTIC OR STEEL (Previously was in the PTST 1 5. Section)</p> <p>1.: Revised to clarify the table is test pressure and test duration requirements for standard construction activity.</p> <p>In Table:</p> <p>Leak Test replaced Leak/Strength Test. Note (1) was added to explain that a Leak Test satisfies both the leak test and strength test requirement in that it will ensure there are no hazardous leaks and qualifies the Design MAOP of the service line.</p> <p>The groups that have been working on this section of the O&M preferred the use of the terms Leak Tests and Strength Test and to no longer use Combination Test. Under Part 192 Code, there is no strength test requirement for service lines.</p> <p>Under Test Pressure for Steel with Design MAOP ≤ 100 psig: added 1.5 x Design MAOP (a) where (a) states "If Design MAOP is greater than 60 psig but less than 100 psig minimum test pressure is 1.5 times Design MAOP."</p> <p>Gas Superintendents wanted the ability to test steel service lines with Design MAOP between 60 psig and 100 psig at 1.5 times the MAOP rather than at a minimum of 150 psig.</p> <p>Under Test Pressure for Steel with Design MAOP >100 psig added a Note (2);</p> <p>Note (2) states If the service line is tested at a pressure that will result in the hoop stress of 20% SMYS or more it shall be tested in accordance with PTST 1 Table D.</p> <p>Note was added to meet the requirement in Part 192.511 when a service line is stressed 20% SMYS or more.</p> <p>Added a statement in the lower section of the table, "If the service has both steel and plastic pipe, then test to the Plastic Pipe Requirements"</p> <p>Eliminates the confusion on how to test service lines that contain both steel pipe and PE pipe. PE pipe has the con-</p>	(new)	Sep-tem-ber 1, 2016

trolling requirements in that PE pipe is tested for a Design MAOP of either 60 psig or 100 psig.

**PTST
1 TA-
BLE B.**

PLASTIC MAIN - ALL PE PIPE SIZES THRU 8" WITH DESIGN MAOP 100 PSIG OR LESS (Previously was in the PTST 1 5. Section)

(new) Sep-tem-ber 1, 2016

1. Revised to clarify table is test pressure and test duration requirements for standard construction activity with plastic main pipe sizes thru 8 inch which includes plastic service lines 2 inch and larger.

In Table:

Leak Test replaced Leak/Strength Test. Note (1) was added to explain that a Leak Test satisfies both the leak test and strength test requirement in that it will ensure there are no hazardous leaks and qualifies the Design MAOP of the pipe.

The groups that have been working on this section of the O&M preferred the use of the terms Leak Tests and Strength Test and to no longer use Combination Test. Under Part 192 Code, there is no strength test requirement for plastic mains.

Under the Duration, replaced the reference link to PTST 2.01 with See 2. below.

2.: Duration information from PTST 2.01 3. Leak Test Duration, is summarized below:

Added duration information and table from PTST 2.01 3. so individual would not have to move back and forth between PTST 1 and PTST 2.01

**PTST
1 TA-
BLE C.**

STEEL MAIN - ALL STEEL PIPE SIZES THRU 30" WITH DESIGN MAOP LESSTHAN 100 PSIG (Previously was in the PTST 1 5. Section)

(new) Sep-tem-ber 1, 2016

1. Revised to clarify table is test pressure and test duration requirements for standard construction activity with steel main pipe sizes thru 30 inch nominal diameter and steel service lines 2 inch and larger nominal diameter with Design MAOP less than 100 psig.

In Table:

Leak Test replaced Leak/Strength Test. Note (1) was added to explain that a Leak Test satisfies both the leak test and strength test requirement in that it will ensure there are no hazardous leaks and qualifies the Design MAOP of the pipe.

The groups that have been working on this section of the O&M preferred the use of the terms Leak Tests and Strength Test and to no longer use Combination Test. Un-

der Part 192 Code, there is no strength test requirement for steel main with Design MAOP of less than 100 psig.

Under Test Pressure for Steel with Design MAOP > 60 psig to < 100 psig added 1.5.x Design MAOP (a) where (a) states "If Design MAOP is greater than 60 psig and less than 100 psig, minimum test pressure is 1.5 times Design MAOP."

Gas Superintendents wanted the ability to test steel lines with Design MAOP between 60 psig and 100 psig at 1.5 times the MAOP rather than at a minimum of 150 psig.

Under the Duration, replaced the reference link to PTST 2.01 with See 2. below.

2.: Duration information from PTST 2.01 3. Leak Test Duration, is summarized below:

Added duration information and table from PTST 2.01 3. so individual would not have to move back and forth between PTST 1 and PTST 2.01

**PTST
1 TA-
BLE D.**

STEEL MAIN - ALL STEEL PIPE SIZES THRU 30" WITH DESIGN MAOP 100 PSIG or GREATER (Previously was in the PTST 1 5. Section)

(new)

Sep-
tem-
ber 1,
2016

1. Revised to clarify table is test pressure and test duration requirements for standard construction activity with steel main pipe sizes thru 30 inch nominal diameter and steel service lines 2 inch and larger nominal diameter with Design MAOP greater than or equal to 100 psig.

This table is separated into two parts; top half is for steel pipe with Design MAOP of 100 psig or greater but less than 30% SMYS and the bottom half is for steel pipe with Design MAOP 30%SMYS or greater.

This separation is consistent with the testing requirements in Part 192 Subpart J

Steel Pipe with Design MAOP of 100 psig or greater but less than 30% SMYS

In Table:

Under the Test Pressure for the Leak Test, add Max. 20% SMYS.

This maximum leak test was added to meet a requirement in Part 192.507 when a pipeline is stressed 20% SMYS or more. The groups that have been working on this section of the O&M made a decision to require a leak test to verify no hazardous leaks were present and then a strength test to establish or validate the Design MAOP.

Under the Test Pressure for the Strength Test, added a Max. See Note (3)

Note (3) states: "Maximum test pressure on steel pipe with Design MAOP of 100 psig or greater should not exceed that

designated by Gas Tech Engineering or Gas Storage Engineering."

To avoid overstressing the pipe, GTE or GSE will specify the maximum test pressure.

Steel Pipe with Design MAOP 30% SMYS or greater

In Table:

Under Design MAOP \geq 30% SMYS added Note (2).

Note (2) states: "Refer to STLP 2.01 7. Design Pressure Steel Pipe Stock Code Table for pressure that would result in stressing pipe to 30% SMYS. If the pipe being tested is not shown in this table, contact Gas Tech Engineering or Gas Storage Engineering or local Gas Engineer for pressure determination."

This provides an easy reference for finding at what pressure the pipe is stressed to 30% SMYS.

Under the Leak Test Duration added Max. 20% SMYS.

This maximum leak test was added to be consistent with the leak test duration on pipe with Design MAOP or 100 psig or greater but less than 30% SMYS. The groups that worked on pressure testing felt that even though Part 192.505 only requires a strength test, it would be a good practice to perform a leak test at a minimum of 100 psig before increasing the test pressure to 1.5 times the Design MAOP.

Under the Strength Test Pressure added Max. Note (3)

Note (3) states: "Maximum test pressure on steel pipe with Design MAOP of 100 psig or greater should not exceed that designated by Gas Tech Engineering or Gas Storage Engineering."

To avoid overstressing the pipe, GTE or GSE will specify the maximum test pressure.

**PTST
1 TA-
BLE E.**

FABRICATED UNIT/ASSEMBLY OR SHORT SECTION OF PIPE (Previously was in the PTST 1 5. Section)

(new)

Sep-
tem-
ber 1,
2016

1. Revised to clarify the table provides test pressure and test duration requirements.

2. Added an explanation of a Fabricated Unit/Assembly.

Fabricated Unit/Assembly is sections of pipe and various fittings which are assembled together either in a shop environment or in the field and then attached to the pipe or connected to the system. Where post installation testing is impractical, the fabricate unit/assembly shall be pre-tested to at least meet the Design MAOP of the system it is being attached. Typical examples of fabricated unit/ assembly are: regulator stations, valve stations, commercial/industrial regulating/metering sets, odorizer stations, pig launcher/receivers, pipeline offset sections, valve

connections, pressure gauge tap, blow-down stacks, equalizer valve set-up, pressure recording connection, bypass facilities and etc.

When sections of pipe and/or fittings are put together and they cannot be tested to meet their Design MAOP once in place, they have to be pre-tested to establish their Design MAOP. This is required even when connecting pressure rated fittings together into a unit/assembly.

This table has now been divided into 2 sections;

PTST 1 Table E. (1) for Fabricated Unit/Assembly, or Short Section of Pipe with Design MAOP less than psig and PTST 1 Table E. (2) for Fabricated Unit/Assembly, or Short Section of Pipe with Design MAOP 100 psig and greater.

PTST 1 Table E. (1) for Fabricated Unit/Assembly, or Short Section of Pipe with Design MAOP less than psig

Leak Test Note (1) replaced Leak/Strength Test,

Note (1) states "The single Leak Test satisfies both the leak test and strength test requirement in that it will ensure there are no hazardous leaks and qualifies the Design MAOP of the unit, assembly, or pipe."

Under Duration, "See Minimum Duration Table" replaces the "Check for leaks with soap or leak detection instr. or Min. 1 Hour Leak Test.

A Minimum Leak Duration Table has been added which lists the minimum test duration based on the size of pipe/fittings being tested.

Gas Superintendents wanted the testing requirements to be consistent with the other tables. It was agreed that the minimum test duration should be based on the pipe/fitting size shown in Tables B and Table C.

Under Test Pressure for Steel with Design MAOP < 100 PSIG, revised to Min. 90 PSIG or 1.5 x Design MAOP (a) Max. 200 PSIG. Where (a) states "If Design MAOP is greater than 60 psig and less than 100 psig, minimum test pressure is 1.5 times Design MAOP."

Gas Superintendents wanted the ability to test steel lines with Design MAOP between 60 psig and 100 psig at 1.5 times the MAOP rather than at a minimum of 150 psig.

PTST 1 Table E. (2) for Fabricated Unit/Assembly, or Short Section of Pipe with Design MAOP 100 psig and greater.

Under the Strength Test Pressure in PTST 1 Table E. (2), added Max. See Note (1)

Note (1) states: "Maximum test pressure on steel pipe with Design MAOP of 100 psig or greater should not exceed that designated by Gas Tech Engineering or Gas Storage Engineering."

To avoid overstressing the pipe, GTE or GSE will specify the maximum test pressure.

Under Design MAOP \geq 30% SMYS added Note (2).

Note (2) states: "Refer to STLP 2.01 7. Design Pressure Steel Pipe Stock Code Table for pressure that would result in stressing pipe to 30% SMYS. If the pipe being tested is not shown in this table, contact Gas Tech Engineering or Gas Storage Engineering or local Gas Engineer for pressure determination."

This provides an easy reference for finding at what pressure the pipe is stressed to 30% SMYS.

**PTST
1 TA-
BLE F.**

FARM TAP - SINGLE CUT - 60 to 450 PSIG INLET PRESSURE (Previously was Table PTST 1 5. I.)

(new)

Sep-
tem-
ber 1,
2016

1. Revise to clarify the table is the test pressure and test duration requirements.

In Table:

Leak Test replaced Leak/Strength Test. Note (1) was added to explain that a Leak Test satisfies both the leak test and strength test requirement in that it will ensure there are no hazardous leaks and qualifies the Design MAOP of the service line.

The groups that have been working on this section of the O&M preferred the use of the terms Leak Tests and Strength Test and to no longer use Combination Test. Under Part 192 Code, there is no strength test requirement for service lines.

Added "Note: All of the piping from the main to the outlet of the farm tap can be tested together at the inlet service line test pressure."

Clarification that all of the farm tap piping can be tested at one time, at the same test pressure as the inlet piping from the main.

Under Outlet Service Line $<$ 2" revised the reference to PTST 1 Table A. and added See Note (4) below.

Under Outlet Service Lines \geq 2" revised the references to PTST 1 Table B if Plastic Service or PTST 1 Table C. or PTST 1 Table D. if Steel Service Lines and added See Note (4) below.

Note (4) states "If the outlet service has both steel and plastic pipe, then test to the plastic pipe requirements."

Since the Design MAOP of the PE pipe is controlling, the testing of the service line should be in accordance with the PE requirements.

PTST 1 TA- BLE G.	<p>FARM TAP - DOUBLE CUT - 451 to 1000 PSIG INLET PRES- SURE (Previously was Table PTST 1 5. J.)</p> <p>In Table:</p> <p>Leak Test replaced Leak/Strength Test. Note (1) was added to explain that a Leak Test satisfies both the leak test and strength test requirement in that it will ensure there are no hazardous leaks and qualifies the Design MAOP of the service line.</p> <p>The groups that have been working on this section of the O&M preferred the use of the terms Leak Tests and Strength Test and to no longer use Combination Test. Under Part 192 Code, there is no strength test requirement for service lines.</p> <p>Under Inlet Service Line < 2" added Note (5).</p> <p>Note (5) states "- A test pressure of 1,181 psig or greater on a 1-1/4 inch service line will stress the pipe to 20% SMYS or more. Service line shall be tested in accordance PTST 1 Table D."</p> <p>Part 192.511 requires a service line that is stressed to 20% SMYS must be tested as a pipeline that operates at or above 100 psig but less than 30% SMYS.</p> <p>Added "Note: All of the piping from the main to the outlet of the farm tap can be tested together at the inlet service line test pressure."</p> <p>Clarification that all of the farm tap piping can be tested at one time, at the same test pressure as the inlet piping from the main.</p> <p>Under Outlet Service Line < 2" revised the reference to PTST 1 Table A. and added See Note (4) below.</p> <p>Under Outlet Service Lines ≥ 2" revised the references to PTST 1 Table B if Plastic Service or PTST 1 Table C. or PTST 1 Table D. if Steel Service Lines and added See Note (4) below.</p> <p>Note (4) states "If the outlet service has both steel and plastic pipe, then test to the plastic pipe requirements."</p> <p>Since the Design MAOP of the PE pipe is controlling, the testing of the service line should be in accordance with the PE requirements.</p>	(new)	Sep- tem- ber 1, 2016
PTST 2.01	<p>Leak Test</p> <p>Revisions were made to make consistent with PTST 1.</p> <p>The items below are essentially a duplication of what is in PTST 1 Requirements.</p> <p>1. A.: Revised to match Part 192 language in that pressure testing is performed to identify "hazardous leaks".</p>	Janu- ary 1, 2016	Sep- tem- ber 1, 2016

1. C.: Revised Gas Tech Engineering's requirements to now reviewing testing requirements for transmission mains/facilities, steel high pressure mains/facilities with Design MAOP of greater than 60 psig. See PTST 1 J. for GTE responsibilities.

1. D.: New item added to address DDC/PDC or Division Engineering's requirements to now reviewing testing requirements for steel distribution mains and services with Design MAOP of 60 psig or less and PE mains and services with Design MAOP of less than 100 psig. See PTST 1 L. for DDC/PDC and Division Engineering responsibilities.

1. E.: New item added for Gas Storage Engineering requirements to include reviewing testing requirements of gas facilities in the Storage Field and Compressor Plants. See PTST 1 K. for Gas Storage Engineering responsibilities

1. F: New item added "Emergency project(s) or maintenance project(s) with Design MAOP 100 psig or less, testing requirements may be specified by Division Engineering."

Allows Division Engineering to handle steel projects where Design MAOP is 100 psig or less. This eliminates the need to contact Gas Tech Engineering for testing requirements for steel mains and services with Design MAOP of 100 psig or less. PE mains and service with Design MAOP of 100 psig already falls under Division Engineering.

1. H.: Updated the Table references.

3. Leak Test Duration

3. A.: Updated the Table reference and deleted "minimum duration of 10 minutes" since that is shown in the PTST 1 Table A.

3. B.: Updated the Table references

3. B. (1): Grammatical revision, "See table below in this section" replaces "See table in section D below".

3. E. : Updated Table reference

4. Leak Test Procedure

4. H.: Added leak detection instrument as a means of check for leaks at tie-in joints.

Since tie-in joints are tested at current operating pressure and gas is the test medium, leak detection instrument can be used.

5. Leak Test Records

5. C.: New item, Leak testing on meter set piping shall be recorded on the meter set plans test stamp."

**PTST
2.02**

Strength Test

Revisions were made to make consistent with PTST 1.

Janu-
ary 1,
2016

Sep-
tem-

UNCONTROLLED IF PRINTED

1. B. Updated the Table references

ber 1,
2016

1. B. (2): Added "Assembly" to PTST 1 Table E.

1. D.: New item, "Maximum test pressure on steel pipe with Design MAOP of 100 psig or greater should not exceed that designated by Gas Tech Engineering or Gas Storage Engineering."

To avoid overstressing the pipe, GTE or GSE will specify the maximum test pressure.

3. Strength Test Procedures

3. G. Added leak detection instrument as a means of check for leaks at tie-in joints.

Since tie-in joints are tested at current operating pressure and gas is the test medium, leak detection instrument can be used.

**PTST
4**

Forms and Reference Materials

Updated

Janu-
ary 1,
2016

Sep-
tem-
ber 1,
2016

Form 01 - Gas Leak & Strength Test Stamp (Rev 01/18/2016)

Added Device Serial Number or ID

Form 02 - Leak & Strength Test Record (Rev 04/01/2016)

Removed the term "Combination Test" and removed (8 Hours or Longer, Requires Chart).Chart is now only required when testing of facilities with Design MAOP of 30% SMYS or greater.

Side note: A committee is currently developing new test stamp/record. Once these have been approved, new stamp/record will be distributed. After which the new stamp/record can be used.

CORRECTIONS, UPDATES & NEW MATERIALS

FORW

Forward

Janu-
ary 1,
2016

Sep-
tem-
ber 1,
2016

5. Contacts

Updated contact list with additional individuals and contact phone numbers

CORR
2.01

Cathodic Protection Design

Janu-
ary 1,
2016

Sep-
tem-
ber 1,
2016

Typo Corrections in 4. Insulating Points section; D. (4) thru D. (7). Tracer wire size is #12 not #14.

CORR 2.03	<p>Coatings</p> <p>1. Approved Coatings</p> <p>1. E. Fittings:</p> <p>1. E. (1): Added fusion bonded epoxy, coal tar epoxy (Bitumastic), field applied epoxy coating, and cold applied tape as other approved coatings for fittings.</p> <p>Previous O&M only had wax tape and hot applied tape listed as approved for fittings. Ameren is and has been purchasing fittings which come with epoxy coating. Field applied epoxy coating and cold applied tape are also approved for below grade use and are approved as a pipe coating.</p> <p>6. Moisture Cure Wrap - New section added</p> <p>Added a table listing the moisture cure wrap that Ameren Illinois is stocking.</p>	Janu- ary 1, 2016	Sep- tem- ber 1, 2016
METR 3.03	<p>Regulator Sizing - 7 Inch W.C. Delivery Pressure</p> <p>The Actaris name was changed to Itron .</p> <p>Revised the table by listing both the Itron B42R and American 1813C regulators that are being used.</p> <p>Due to production lead times, Ameren Illinois is switching back and forth between these two manufacturers</p> <p>Correction in note (2) changing the maximum inlet pressure for the Itron regulators with 1/4" orifice to 28 psig, reduced from 45 psig due to internal relief capacity.</p>	Janu- ary 1, 2016	Sep- tem- ber 1, 2016
METR 3.04	<p>Regulator Sizing - 2 PSIG Delivery Pressure</p> <p>The Actaris name was changed to Itron</p> <p>Revised the table by listing both the Itron B42R and American 1813C regulators that are being used.</p> <p>Due to production lead times, Ameren Illinois is switching back and forth between these two manufacturers</p> <p>Corrected Spring Color for 1" x 1" Itron CL-31N. Spring should be Green. Error in manufacturer's literature due to change in spring manufacturer. Previous manufacturer painted spring blue.</p>	Janu- ary 1, 2016	Sep- tem- ber 1, 2016
METR 3.05	<p>Regulator Sizing - 5 PSIG Delivery Pressure</p> <p>The Actaris name was changed to Itron</p> <p>Corrected Spring Color for 1" x 1" Itron CL-31N. Spring should be Green. Error in manufacturer's literature due to change in spring manufacturer. Previous manufacturer painted spring blue.</p>	Janu- ary 1, 2016	Sep- tem- ber 1, 2016

METR 3.06	<p>Regulator Sizing - 10 PSIG Delivery Pressure</p> <p>The Actaris name was changed to Itron</p> <p>Corrected Spring Color for 1" x 1" Itron CL-31N. Spring should be Green. Error in manufacturer's literature due to change in spring manufacturer. Previous manufacturer painted spring blue</p>	Janu- ary 1, 2016	Sep- tem- ber 1, 2016
PMRK 0	<p>Table of Contents</p> <p>New section added:</p> <p>PMRK 3.05 Rhino Pipeline Markers - TriView pipeline marker</p>	July 1, 2012	Sep- tem- ber 1, 2016
PMRK 3.05	<p>Rhino Pipeline Markers - New Section</p> <p>Installation instructions for the Rhino TriView pipeline marker. Ameren Illinois stocks 2 lengths: 16 02 685 is the 66 inch tall marker and 16 02 687 is the 120 inch tall marker</p>	(new)	Sep- tem- ber 1, 2016
POLY 1	<p>Requirements</p> <p>8. Weak Link - Added Cumberland Product Weak Link</p> <p>8. C.: Changed format and name to Mechanical Weak Link</p> <p>8. D. Cumberland Product Weak Link - These are a short section of MDPE pipe that is butt fused to the pipe being installed. The weak like has a groove milled in the center that will prevent the pipe from being overstressed. A listing of catalog numbers is included and the weak links can be ordered through Groebner & Associates.</p> <p>New product that has been successfully field tested by Ameren Illinois. Product has been approved and added to the Specialized Tool and Equipment SharePoint Site.</p>	Janu- ary 1, 2016	Sep- tem- ber 1, 2016
PTST 0	<p>Table of Contents</p> <p>Added a new section follow the Requirement - PTST 1, Test Pressure and Duration Requirement Tables</p> <p>1. Service Lines - Less Than 2" Diameter; Plastic or Steel - PTST 1 Table A.</p> <p>2. Plastic Main - All PE Pipe Sizes thru 8" with Design MAOP 100 PSIG or Less - PTST 1 Table B.</p> <p>3. Steel Main - All Steel Pipe Sizes thru 30" with Design MAOP Less Than 100 PSIG - PTST 1 Table C.</p> <p>4. Steel Main - All Steel Pipe Sizes thru 30" with Design MAOP 100 PSIG or Greater - PTST 1 Table D.</p> <p>5. Fabricated Unit/Assembly or Short Section of Pipe - PTST 1 Table E.</p> <p>PTST 1 Table E (1) - Fabricated Unit/Assembly or Short Section of Pipe with Design MAOP <100 PSIG</p>	Janu- ary 1, 2016	Sep- tem- ber 1, 2016

PTST 1 Table E (2) - Fabricated Unit/Assembly or Short Section of Pipe with Design MAOP \geq 100 PSIG

6. Farm Tap - Single Cut - 60 to 450 PSIG Inlet Pressure - PTST 1 Table F.

7. Farm Tap - Double Cut - 451 to 1000 PSIG Inlet Pressure - PTST 1 Table G.

Forms and Reference Materials

Forms:

Updated Gas Leak & Strength Test Stamp

Updated Leak & Strength Test Record

RNST
2.01

Reinstating Mains and Services

Below revisions were made to be consistent with PTST 1, the previous references to PTST1 is being replaced by specific Table designations.

January 1,
2016

September 1,
2016

2. Reconnection of Temporarily Disconnected Services

2. A.: "See the appropriate Table under PTST 1 5. Testing, to select the appropriate test pressure and test duration table."
Replaced See PTST 1.

3 Reconnection of Temporarily Disconnected Farm Tap Services

3. B. (1): Update reference to PTST 1 Table F, "On farm tap with one regulator, the outlet piping from the regulator to the meter valve shall be pressure tested as specified in PTST 1 Table F. Farm Tap - Single Cut - 60 to 450 PSIG Inlet Pressure"

3. B. (2): Update reference to PTST 1 Table G,; "When the downstream (second cut) regulator is removed from a farm tap with two stage pressure reduction, the outlet piping from the downstream (second cut) regulator to the meter valve shall be pressure tested as specified in PTST 1 Table G. Farm Tap - Double Cut - 451 to 1000 PSIG Inlet Pressure"

3. B. (3): Update reference to PTST 1 Table G; "When the upstream (first cut) regulator is removed from a farm tap with two-stage pressure reduction, piping between the first cut regulator and inlet to the second cut regulator shall be tested as described in PTST 1 Table G. Farm Tap - Double Cut - 451 to 1000 PSIG Inlet Pressure."

4. Reconnection of Temporarily Disconnected Mains

4. C. Facilities Lifted From a Trench

4. C. (2): Update reference to PTST 1 5. "Mains which are lifted out of a trench and placed in a different location shall be pressure tested in the same manner as new lines in their final location. See PTST 1 5. Testing, to select the appropriate test pressure and test duration table."

UNCONTROLLED IF PRINTED

4. D. Facilities Cut Into Sections: Update reference to PTST 1 5. "New segments of main installed between the undisturbed sections of main shall be tested in the same manner as a new main in that location. See PTST 1 5. Testing, to select the appropriate test pressure and test duration table."

5. Reinstating Service in Abandoned Lines

5. B.: Update reference to PTST 1 5. "The facility shall be tested as though it were a new line being installed in the same location. See PTST 1 5. Testing, to select the appropriate test pressure and test duration table."

6. Records

6. A.: Revised to "All pressure test information will be maintained in Maximo or in the As Built Construction file."

SERV
2.03

Farm Tap Installation

Revisions were made to make consistent with PTST 1.

1. G.: New, "Farm tap a on gas pressure system with a Design MAOP greater than 1000 psig shall be designed or reviewed by Gas Tech Engineering (GTE).

1. H. New, "Pressure containing facilities similar to a farm tap located within gas storage fields and compressor plants shall be designed by Gas Storage Engineering (GSE)

2. Standard Installation

2. C.: Wording change, Please refer to the Farm Tap Capacity tables in Section 7 to verify flow capacity for a specific installation

4. Testing

4. A.: Updated reference to specific tables; "Farm tap piping shall be tested in accordance with the appropriate Table PTST 1 5. F. or Table PTST 1 5. G.

7. Farm Tap Capacity Tables

7. B. Single Cut Farm Tap Capacity table and

7. C. Double Cut Farm Tap Capacity table:

Maximum Flow values for the high pressure EFV's replaces the Trip Flow Rate. This is consistent with SERV 2.02 Excess Flow Valve tables.

7. C.: Added the orifice size and set pressure range for the 3/4" Fisher 627 regulator, 3/32" orifice and 70-150 psig.

January 1,
2016

September 1,
2016

SERV
3.06

Farm Tap, Single-Cut, 60 - 450 PSIG Inlet Pressure

Stock Code correction for Item 16, correct stock code is 19 22 506 which is the Central Plastic Coupling.

January 1,
2016

September 1,
2016

TAPS 1	<p>Requirements</p> <p>Revisions were made to make consistent with PTST 1.</p> <p>7. Gauge, Blow-down, By-pass Fittings</p> <p>7. C.: Revised to; "The fitting shall be pressure tested in accordance with PTST 1 5. prior to tapping."</p> <p>8. Testing</p> <p>8. A.: New, "Testing of the fittings and associated piping"</p>	January 1, 2016	September 1, 2016
VALV 2.04	<p>Kerotest Gate Valve Maintenance</p> <p>4.Primary Repacking Procedure</p> <p>4. B. Corrected reference to drawing bullet point (N) from (O).</p> <p>6. Bonnet Leak Repair</p> <p>6. B.: Added Kerotest's Model 1 Gate Valve Bonnet Leak Repair Procedures to VALV 4.</p> <p>6. C. (1): Corrected an error, it is the bonnet gasket that is to be coated with Slic-Tite TFE paste or equivalent not the bonnet bolts.</p>	January 1, 2011	September 1, 2016

REFERENCE MATERIALS

CORR 0	<p>Table of Contents</p> <p>CORR 4: Added</p> <p>Reference 22. - Trenton MC Overwrap</p> <p>Reference 23. - Syntho-Sleeve Installation Guide</p>	January 1, 2016	September 1, 2016
CORR 4	<p>Forms and Reference Materials</p> <p>Added</p> <p>Reference 22. - Trenton MC Overwrap</p> <p>Reference 23. - Syntho-Sleeve Installation Guide</p>	January 1, 2016	September 1, 2016
<u>LEAK</u> <u>0</u>	<p>Table of Contents</p> <p>LEAK 4 Added new ethane detector reference</p> <p>Reference 17. - Sensit IRED Manual</p> <p>Reference 18. - Sensit IRED Quick Start Instructions</p>	January 1, 2016	September 1, 2016
<u>LEAK</u> <u>4</u>	<p>Forms and Reference Materials</p> <p>Added: Added new ethane detector reference</p> <p>Reference 17. - Sensit IRED Manual</p> <p>Reference 18. - Sensit IRED Quick Start Instructions</p>	January 1, 2016	September 1, 2016

UNCONTROLLED IF PRINTED

LOCT 0	Table of Contents LOCT 4 Added 31. Radiodetection RD7100 Locator User Guide 32. Radiodetection RD7100 Locator Operation Manual 33. Radiodetection RD8100 Locator User Guide 34. Radiodetection RD 8100 Locator Operation Manual	Janu- ary 1, 2016	Sep- tem- ber 1, 2016
LOCT 4	Forms and Reference Materials Added New locators 31. Radiodetection RD7100 Locator User Guide 32. Radiodetection RD7100 Locator Operation Manual 33. Radiodetection RD8100 Locator User Guide 34. Radiodetection RD 8100 Locator Operation Manual	Janu- ary 1, 2016	Sep- tem- ber 1, 2016

Supersedes: January 1, 2016

CHANGE SUMMARY

January 1, 2016

Change Summary January 1, 2016

Docu- ment	Change Summary	Previ- ous Docu- ment Dated	Cur- rent Docu- ment Dated
FORW	Forward Move Materials up to Standards & Materials with Eddie Lynch being the contact person since Stan Treat retired.	De- cem- ber 1, 2014	Janu- ary 1, 2016
ABND 4	Forms and Reference Materials Corrected the Header title	Janu- ary 1, 2013	Janu- ary 1, 2016
ACIG 2.01	Work Area Protection 2. Tools and Equipment 2. B.: Removed "potentially", "Cell phones or other consumer products that are not labeled as intrinsically safe shall not be taken into a gaseous atmosphere." 5. Isolating Pipeline Segments on Planned Work to Minimize the Potential of Ignition 5. B. Revised to, "No portion of a pipeline should be cut under pressure. The flow of gas should be shut off or minimized by the use of line valves, stopping equipment, bags, stoppers, or pipe squeeze tools." SMR Team felt that it is unsafe to cut any size pipe when it is still under pressure so they removed the two inch and larger pipe. 5. D. (4): Added stock code 16 01 410 for Lock-Out tags	Janu- ary 1, 2014	Janu- ary 1, 2016
APPR 0	Table of Contents APPR 2.01 Gas Journeyman Changed section titles for sections 2 thru 10 APPR 2.06 Changed to Gas Meter Specialist Program	Janu- ary 1, 2011	Janu- ary 1, 2016
APPR 2.01	Gas Journeyman Gas Training personnel have completely revised this docu- ment. The document is now broken down by Training Sessions and what topics are to be covered in each session.	Janu- ary 1, 2011	Janu- ary 1, 2016
APPR 2.06	Gas Meter Specialist Program Changed the title from Gas Meter Changer Program	Janu- ary 1, 2011	Janu- ary 1, 2016

UNCONTROLLED IF PRINTED

BORE 0	<p>Table of Contents</p> <p>BORE 2.04 Boring Across or Near Sewer Lines</p> <p>Inserted new section "3. Camera Inspection of High Risk Sewer Laterals</p> <p>Added BORE 4 Forms and Reference Materials</p> <p>Added reference material for the sewer listening device and accessories.</p>	<p>January 1, 2011</p>	<p>January 1, 2016</p>
BORE 2.01	<p>Boring Location Criteria</p> <p>4. Boring Site Preparation</p> <p>4. J.: Added a sentence - "Pot hole shall extend eighteen (18) inches either side of the locator's marks."</p> <p>Clarify that the hand/vacuum excavation must be done for the full width of the tolerance zone, 18 inches either side of the marks.</p> <p>4. J. (1) & (2): Removed the language that the covered material should be removed down to and below the planned bore path and the bore head and back reamer should be observed entering and leaving the pot hole.</p> <p>SMR Team didn't feel this language was necessary since 4. K. was being inserted.</p> <p>4. K.: Inserted new: "All marked buried facilities crossing the proposed bore path or are within the eighteen (18) inch tolerance zone should be exposed or verified not to be in conflict with boring, back reaming or pneumatic piercing tool operations. Pot holes should be of such depth to ensure the buried facilities will not be damaged by boring and back reaming operations."</p> <p>SMR Team inserted this language to simplify the procedures by stating that marked buried facilities should be exposed or verified not to be in conflict with the boring, back reaming, or pneumatic piercing tool and that pot holes should be of such depth to ensure buried facilities will not be damaged.</p> <p>4. M.: Changed reference for sewer listening device to "Refer to BORE 2.04 4. Construction Steps for sewer listening device requirements."</p> <p>4. O.: Revised language by adding outside of entrance trench: "For conventional boring with bore rods, the approach trench should be 1-1/2 times the length of the bore rod with no more than two (2) ten (10) feet sections of rods exposed outside of entrance pit at one time."</p> <p>SMR Team added "outside of entrance pit" This is to clarify the intent from a safety prospective of not exposing an individual or the public to more than approximately 20 feet of drill rods.</p>	<p>April 1, 2012</p>	<p>January 1, 2016</p>

4. P.: Revised language to: "As a rule of thumb, the entrance angle of the bore rod should normally be between 8 degrees and 18 degrees. However, conditions may warrant a steeper angle as long as it does not exceed minimum bending radius of the rod or pipe. A minimum of one complete length of drill rod (10 feet for smaller rigs and 30 feet for larger rigs) should be utilized before leveling out to the appropriate depth."

SMR Team revised the language slightly to allow for flexibility to exceed the normal 8 to 18 degree entrance angle provided the drill rod's manufacturer's minimum bend radius is not exceeded.

BORE
2.02

Boring Operations

Janu-
ary 1,
2012

Janu-
ary 1,
2016

1. B.: Added "Ameren Illinois Safety maintains the Job Briefing forms which are available on the Safety's SharePoint site."

Since the Safety SharePoint site maintains the most current version of the Job Briefing forms, the sample form is being removed from EXCV 4.

2. Boring Safety

2. B. (2): Grammatical only by adding reference to EXCV 2.03 for applying safe work practices at an excavation site.

2. B. (3): Added "Ensure excavations are in accordance with OSHA Standards before entering. See EXCV 1

2. C.: Inserted new item to specifically address safety around potentially energized buried cable. "Since boring operations may encounter an energized electric cable which could energize the boring machine, the following safety precautions should be followed:

2. C. (1): "The area around the boring machine should be demarcated to warn persons of the potential electrical hazard. Items such as, but not limited to, cones, tape, or barricades can be used to demarcate the area."

2. C. (2): "Other than the boring machine operator, no one should touch the machine during the boring operations".

2. C. (3): "Directional boring units should be grounded by the use of the grounding rod and cable furnished by the manufacturer or an equivalent."

2. C. (4): "Boring machine operators must remain in the operator's seat, where applicable, and not allow any part of their body to contact the ground while the boring machine is in operation."

2. C. (5): "All personnel working in the vicinity of the covered work, who may be exposed to subsurface electrical hazards, must wear boots meeting ASTM Standards F2412-05 and F2413-05 Electrical Hazard (EH) rating. These boots must be worn during the time when electrical hazards may be encountered, i.e., boring advancement, active trenching or plowing, jackhammering, etc. During work in muddy or wet conditions,

rubber insulating EH-rated boots (either overboots or safety-toed boots) must be worn."

2. C. (6): "Directional bore personnel include machine operator, locator and gas personnel working in the vicinity of the bore path from the machine to the bore head."

2. D.: Revised to read: "Only those gas personnel who through training or experience have the knowledge, skills, and abilities in the safe operation of the boring equipment are permitted to operate such equipment. A gas apprentice may operate boring equipment as part of their OJT requirements as long as an experienced operator is present, in direct observation of the apprentice, and can react immediately to AOC's. Additionally, gas field personnel who are inexperienced in the operation of boring equipment may operate the equipment if under the direct observation of an experienced operator".

Replaced Operator Qualified with "personnel who through training or experiences have the knowledge, skills, and abilities". This language is consistent with that which defines Qualified.

The SMR Team along with the Safety Specialist revised the Safety section in an effort to make it consistent with the Ameren Illinois Safety Manual.

3. Prior to Beginning Operations - New Section

3. A.:" Ensure proper job site protection and required traffic control is in place. Refer to the Ameren Utility Work Zone Traffic Control Field Manual."

3. B.: "All marked buried facilities crossing the proposed bore path or are within the eighteen (18) inch tolerance zone should be exposed or verified not to be in conflict with boring, back reaming or pneumatic piercing tool operations. Pot holes should be of such depth to ensure the buried facilities will not be damaged by boring and back reaming operations."

3. C.: "If sewer line, main or laterals, are not exposed or their depth are not verified, Gas Supervisor should refer to BORE 2.04 for available options."

3. D.: "When necessary, measures to avoid interfering with overhead electrical, telephone and cable lines should be made."

3. E.: "Determine who will be communicating with the boring machine operator during the actual boring operation and the means of communicating, hand signals or radio."

3. F.: Gas Supervisor, crew leader, or foreman should conduct an in-depth job briefing covering all of the subjects on the Job Briefing Form with entire crew.

The above items were included under each of the boring operations so the SMR Team felt they should be moved into their own section instead of repeating them.

UNCONTROLLED IF PRINTED

4. Conventional Rod Boring Operations

4. C.: Revised to read: "Assemble rods with no more than two (2) rods, approximately 10 feet each, exposed outside of the entrance pit at one time."

SMR Team added "outside of entrance pit" This is to clarify the intent from a safety prospective of not exposing an individual or the public to more than approximately 20 feet of drill rods.

4. E.: Added a sentence when boring across or near water and/or sewer lines. "Refer to BORE 2.04 if sewer line location and depth cannot be physically verified."

Reference added to address boring across or near sewer line.

4. F.: Revised to read: "If pot holes have been excavated to expose other underground facilities and the proposed bore path, workers should observe the pot hole as the drill head, back reamer and rods cross to ensure the facility has not been damaged and to check the depth of the bore. If drill head and rods are not visible in the pot hole a determination must be made if the drill path is in proper alignment or at the proper depth. Refer to Prior to Beginning Operations section above for information regarding depth of pot hole."

SMR Team added language when pot hole(s) expose the proposed bore path, the bore head, back reamer, and/or rods should be observed passing through the pot hole.

4. H.: Added a reference to Table 1 for back reamer sizes.

5. Pneumatic Piercing Tool Operations.

5. D.: Added checking "air hose connectors" to the items gas field personnel should inspect prior to beginning operations.

5. E.: Inserted new: "Air hose connections should be secured by positive means to prevent accidental disconnection. Thor self-locking connectors and Chicago fitting connectors with safety clip provide secured connections."

Safety Specialist provided information on which connectors have safety clips.

5. K.: Only grammatical change in 1st sentence to "The tail hose should be marked to provide workers with an indication of the tool's progress."

6. Directional Drilling Operations

6. G.: Revised to "It is permissible to drill the pilot hole and pre-ream/back-ream over multiple days. However, final pull-back of the pipe shall be continuous until completed."

SMR Team wanted to clarify that drilling and back reaming are a separate operation from pulling pipe. As such, they can be performed over multiply days. However, pulling pipe through the bore should be a continuous operation until complete.

6. H.: Clarification, added "whenever possible" to "Drilling should proceed downhill whenever possible to ensure that the drill mud remains in the hole."

SMR Team wanted to add some flexibility.

6. I: Revised to read: "If pot holes have been excavated to expose other underground facilities and the proposed bore path, workers should observe the pot holes as the drill head, back reamer and rods cross to ensure the facility has not been damaged and to check the depth of the bore. If drill head and rods are not visible in the pot hole a determination must be made if the drill path is in proper alignment or at the proper depth. Refer to Prior to Beginning Operations section above for information regarding depth of pot hole."

SMR Team added language when pot hole(s) expose the proposed bore path, the bore head, back reamer, and/or rods should be observed passing through the pot hole.

6. J.: Grammatical by adding "or permits" to "Check and comply with regulations or permits with specified burial depths."

6. R.: Added some additional rule of thumb language regarding the entrance angle of the bore rods. "As a rule of thumb, the entrance angle of the bore rod should normally be between 8 degrees and 18 degrees. However, conditions may warrant a steeper angle as long as it does not exceed minimum bending radius of the rod or pipe. A minimum of one complete length of drill rod (ten (10) feet for smaller rigs and thirty (30) feet for larger rigs) should be utilized before leveling out to the appropriate depth."

SMR Team felt the addition of the 8 to 18 degrees was more understandable and went along with the boring machine and rod manufacturer's recommendations.

6. W.: Removed "of 8 inch or less diameter pipe". So now reads "The diameter of the back-reamed hole should typically be greater than 1.5 times the nominal outside diameter of the pipe."

6. X.: For pipe diameters 10 inch or greater, added "minimum" to the 6 inches greater than the pipe OD for the back reamer size.

Added flexibility by not restricting the back reamer to be 6 inches larger than the pipe OD. Team members knew that in many cases the back reamer used with large diameter pipe was larger.

BORE
2.03

Pipe Installation

2. PE Pipe

2. C.: Added "The wire ends should be connected." when pulling back two tracer wires with long and/or difficult bores.

July 1,
2012

Janu-
ary 1,
2016

2. D.: Inserted a new item dealing with stainless steel tracer wire. "Consideration should also be given to using stainless steel tracer wire for long and/or difficult directional bores or plow-ins. When stainless steel wire is installed with main, a test station should be brought up at the location where the stainless wire meets the copper wire. A lead from each wire should be run up and terminated in the test station. If installation of a test box is not possible or feasible, the stainless and copper tracer wires can be connected in the same manner as copper service line tracer wire is connected to stainless steel main line tracer wire. See POLY 1"

Stainless steel wire is stronger than copper wire and less susceptible to breakage due to stresses encountered in long directional bores. Some operational areas have been successfully using the stainless steel wire so it is necessary to include it in the O&M. Corrosion Control group's recommendation is to install a test lead box where the stainless and copper wire would connect when possible.

2. T.: Added a reference to BORE 2.02 3. Prior to Beginning Operations for pot hole depth requirements

3. Steel Pipe

3. E.: Added a reference to BORE 2.02 3. Prior to Beginning Operations for pot hole depth requirements

BORE 2.04

Boring Across or Near Sewer Lines

January 1, 2013 January 1, 2016

2. Pre-Construction Steps

2. G. (3): Grammatical correction only "4. Construction Steps below replaces 3. H."

4. Construction Steps

4. G.: Added "See BORE 4 Reference Materials for instruction manuals."

Added instruction manuals for the Yellow Box sewer listening device and accessories.

BORE 4

New: Forms and Reference Materials

January 1, 2016

Reference 01 - Yellow Box WMS-1B Instructions

Reference 02 - Comtek BST-50b Manual

Reference 03 - Comtek PR-216 Operator Manual

Reference 04 - Shure VP64 User Guide

CONF 1

Requirements

January 1, 2011 January 1, 2016

1. A. New item: "Confined spaces containing gas equipment such as vaults/pits and excavations are regulated by PHMSA and those requirements are addresses in other O&M sections such as EXCV and VALT."

This was added by the Safety Specialist to clarify that working in confined spaces that contain gas equipment will not fall under this section of the O&M. They will be addressed in other sections of the O&M.

1. D.: New item, "Entry into crawl spaces or attic should be minimized and only performed when other options for lighting appliances are not available. Workers shall not enter crawl spaces or attic to investigate gas leaks. Shut-in tests should be used to investigate gas leaks on piping in crawl spaces or attics."

This language is consistent with Ameren Illinois' Field Safety Manual regarding working in crawl spaces and attics.

CORR 0	<p>Table of Contents</p> <p>Forms and Reference Materials</p> <p>Added:</p> <p>Reference 13 Dryconn 50100-56-visiLock</p> <p>Reference 14 Dairyland Over Voltage Protector Instructions</p> <p>Reference 15 Denso Protal 7200 Repair Cartridge Data Sheet</p> <p>Reference 16 Trenton EON 1000 GP Instructions</p> <p>Reference 17 Denso Protal 7125 Instructions</p> <p>Reference 18 Denso Protal 7200 Instructions</p> <p>Reference 19 Trenton Fill-Pro_PM-GP</p> <p>Reference 20 Trenton Wax Tape Systems Brochure Rev10</p> <p>Reference 21 Denso-Glass-Outerwrap</p>	De- cem- ber 1, 2014	Janu- ary 1, 2016
CORR 1	<p>Requirements</p> <p>8. Cathodic Protection Monitoring</p> <p>8. B.: Isolated Structures - New Heading</p> <p>(1) Isolated structures that are cathodically protected shall be monitored on a sampling basis. At least 10% of the isolated structures in a community shall be monitored each year so that all services are tested in each ten (10) year period. The test shall include a P/S reading.</p> <p>(2) Isolated structures include:</p> <p>(a) Isolated service lines:</p> <p>(b) Isolated distribution and transmission mains less than 100 feet:</p> <p>(c) Isolated fittings:</p>	De- cem- ber 1, 2014	Janu- ary 1, 2016

(3) Description in the tables was revised to isolated structures Combined the previous 8. B. Isolated Services, 8. C. Isolated Mains Less Than 100', and 8. D. Isolated Fittings into Isolated Structures. These isolated items are all lumped into one grouping for each community. The required monitoring is 10% of the group annually.

13. Atmospheric Corrosion

13. E. Atmospheric Corrosion

13. E. (3): Added "high pressure distribution", "Atmospheric corrosion shall be inspected to ensure that the pit depth is not greater than 10% of the original wall thickness on transmission and high pressure distribution pipeline facilities and 70% of the original wall thickness on distribution pipeline facilities. This inspection will be documented on the Corrosion and Steel Damage Evaluation form within ClickMobile. See CORR 2.31"

14. Pipeline Facilities That Need to Be Painted

14. B. (1): Added "within ClickMobile" as to where these facilities will be documents.

**CORR
2.01**

Cathodic Protection Design

July 1,
2014

Janu-
ary 1,
2016

4. Insulating Points

4. C. (2): Large Distribution Station or Town Border Station with Steel Outlet System

4. C. (2) (a): Added "Consult with Corrosion Control personnel to determine if a Lightning Arrestor needs to be installed. See CORR 2.25 3. H. for Dairyland Over Voltage Protector (Stock Code 4922423)"

4. C. (3): Delivery Station

4. C. (3) (a): Added "Consult with Corrosion Control personnel to determine if a Lightning Arrestor needs to be installed. See CORR 2.25 3. H. for Dairyland Over Voltage Protector (Stock Code 4922423)"

Sketches show a Lightning Arrestor but these are an optional item depending on if there are any high voltage overhead lines nearby. Corrosion Control personnel will determine if an ar- restor needs to be installed.

4. D. Bonding

4. D. (4) Extending New Plastic Lateral from Existing Steel

4. D. (4) (a): Added "Consideration should be taken for attach- ing and bringing a #8 wire off of the steel pipe to identify it sep- arately from the #14 tracer wire that is installed with the PE main."

4. D. (5) Extending New Plastic from End of Existing Steel

4. D. (5) (a): Added "Consideration should be taken for attaching and bringing a #8 wire off of the steel pipe to identify it separately from the #14 tracer wire that is installed with the PE main."

4. D. (6) New Plastic Installed Between Two Sections of Existing Steel

4. D. (6) (a): Added "Consideration should be taken for attaching and bringing a #8 wire off of the steel pipe to identify it separately from the #14 tracer wire that is installed with the PE main."

4. D. (7) Relocating Existing Steel with Plastic

4. D. (7) (a): Added "Consideration should be taken for attaching and bringing a #8 wire off of the steel pipe to identify it separately from the #14 tracer wire that is installed with the PE main."

Corrosion Control personnel suggested that a #8 wire be used as a test lead attached to the steel pipe. That way a person could distinguish between the test lead from the steel pipe and the #12 tracer wire with the PE pipe.

5. Insulating Materials

5. C. Weld End Insulators - Deleted the table and added reference to STLP 3.05 - Weld End Insulators where all of the stock coded weld end insulators are listed.

**CORR
2.03**

Coatings

1. Approved Coatings

1. A. New Pipe Installation

1. A. (1): Direct Bury Installation:

Revised to require girth welds on pipe 12" and larger to be coated with liquid epoxy. Girth welds on pipe smaller than 12" can still be coated with an approved hot or cold applied tape or with liquid epoxy coating.

1. A. (2) Directional Drilling Installation

1. A. (2) (a): Removed the use of a sacrificial hot wrap as an overwrap for the liquid epoxy coating on girth welds on transmission and high pressure distribution pipe. The approved overwrap is the moisture cured wrap.

1. A. (2) (b): Revised to require girth welds on distribution pipe 12" and larger to be coated with liquid epoxy and covered with either a sacrificial hot wrap or moisture cured wrap. Girth welds on distribution pipe smaller than 12" can still be coated with two layers of hot wrap or the liquid epoxy coating.

July 1, 2014 January 1, 2016

Corrosion Control feels that for the larger diameter pipe the liquid epoxy provides better protection for maintaining cathodic protection.

1. F. Soil to Air Interface Zone

1. F. (1): Added a reference to CORR 1 13. D which covers disbonded coating.

1. F. (4): New: "All approved underground coatings that extend above grade (i.e. coal tar, FBE, extruded polyethylene, hot wrap) on newly installed risers shall be over coated approximately twelve (12) inches above grade and below grade using a continuous application method of a UV resistant coating such as cold applied tape or cold applied wax tape at the soil to air interface."

For new installation of above grade facilities where the buried steel pipe is coming above grade, Gas Tech Services and Corrosion Control feels that additional coating protection is needed.

1. G. Above Grade Facilities

Added examples of approved coating materials for above grade facilities.

6. Approved Paint Specifications

6. A. (4) (b): Added Rustoleum Hunter Green aerosol spray paint

CORR 2.09

Protal 7200

2. Application

2. A.: Removed the note that Gas Tech Support has prepared kits.

2. C. Surface Preparation

2. C. (1): Revised the surface profile to 2.5 - 5 mils as recommended by the manufacturer.

2. F. Mixing and Application

2. F. (4): Increased the final thickness to 40 to 70 mil wet film thickness has recommended by the manufacturer.

2. H. inspection/Testing

2. H. (3): Revised to "Holiday testing should not exceed the maximum voltage per average mil thickness shown in the Inspection Voltage table in CORR 2.15."

January 1, 2013

January 1, 2016

CORR 2.10

Protal 7125

2. Application

2. A.: Removed the note that Gas Tech Support has prepared kits.

January 1, 2013

January 1, 2016

2. C. Surface Preparation

2. C. (1): Revised the surface profile to 2.5 - 5 mils as recommended by the manufacturer.

2. F. Mixing and Application

2. F. (4): Increased the final thickness to 40 to 70 mil wet film thickness has recommended by the manufacturer.

2. H. inspection/Testing

2. H. (3): Revised to "Holiday testing should not exceed the maximum voltage per average mil thickness shown in the Inspection Voltage table in CORR 2.15."

**CORR
2.19**

Cathodic Protection Test Points

1. Test Point

1. A.: Revised to - "Establish at least 1 test point on each cathodically protected structure (typically at least 1 test point in each quarter section).

January 1,
2014

January 1,
2016

**CORR
2.23**

Clearing Shorted Pipelines

3. Preformed FRP Spacers - Type 120 - Stocked

3. B Installation

3. B. (2): New, "Pipe support for above grade piping operating at over 60 psig and larger than four (4) inch diameter - Install insulator between pipe support(s) and the pipe. Apply Protal 7200 (CORR 2.09) or Protal 7125 (CORR 2.10) liquid epoxy coating to the FRP and to bottom of pipe as an adhesive and then press the FRP spacer against the pipe. Install pipe support under the FRP before the Protal cures."

Additional protection against corrosion is needed between pipe supports and the pipe. Pipe supports may come with a rubber pad but they often fall out. These performed spacers will provide better protection.

April
1,
2012

January 1,
2016

**CORR
2.28**

Evaluation of Corrosion

2. Distribution Piping (60 PSIG and Below)

2. A.: Added "The maximum allowable pit depth on distribution piping is 70% of the original wall thickness."

2. B. Measuring Pitted Areas (Underground or Atmospheric Corrosion

2. B. (5): Revised to "If pit depths exceed the allowable depths in Table 1, contact Division Gas Engineer or Corrosion Control Tech for further evaluation and proper corrective action."

3. Transmission or High Pressure Distribution Piping (Over 60 psig)

December 1,
2014

January 1,
2016

3. A.: Added "to less than 90% of the nominal wall thickness", "If corrosion has reduced the remaining wall thickness to less than required for the maximum allowable operating pressure or to less than 90% of the nominal wall thickness, the corroded pipe must be repaired or replaced to restore the serviceability of the piping, or the operating pressure reduced commensurate with the strength of the pipe based on actual remaining wall thickness. The maximum allowable pit depth on Transmission and High Pressure Distribution piping is 10% of the original wall thickness."

3. B. New "If corrosion has reduced the wall thickness by more than 10%, Corrosion Control shall be contacted before any corrective action is taken. Corrosion Control along with Gas Tech Engineering will determine the appropriate corrective action to be taken."

3. C. Measuring Pitted Areas (Underground or Atmospheric Corrosion)

3. C. (5): Revised to "If pit depths exceed the allowable depths in Table 2, contact Corrosion Control Tech or Gas Technical Services who will follow the Analytical Method in Figure 2 for further evaluation and proper corrective action."

4. Flow Chart for the Analytical Method

Added a note "Where the flowchart has contact Gas Technical Services this would include Corrosion Control personnel."

6. Pipe Pit Gauge

6. B.: Corrected Corrosion and Steel Damage Evaluation form.

7. Pipe Thickness Gauge

7. B.: Corrected Corrosion and Steel Damage Evaluation form.

CORR 2.29	Records 2. Construction Order Review Processes 2. B. Belleville Design Center/Peoria Design Center 2. B. (c): Updated the Corrosion Techs areas of responsibility	De- cem- ber 1, 2014	Janu- ary 1, 2016
CORR 3.02	Anode Test Station Installation 14.: New "Record measurements and provide a sketch or place the information on a copy of Byers map and submit to a Poster for recording in the electronic mapping system." Location of anodes needs to be included in the electronic mapping system for accurate cathodic protection maps.	July 1, 2014	Janu- ary 1, 2016
CORR 3.14	Test Lead Wire Attachment 6. Test Lead Attachment Coating	July 1, 2014	Janu- ary 1, 2016

- 6. B. Handy Cap (19 62 336)
- 6. B. (1) Installation
- 6. B. (1) (e): Grammatical only, Cad Weld replaces welded

CORR 4	Forms and Reference Materials Added: Reference 13 Dryconn 50100-56-visiLock Reference 14 Dairyland Over Voltage Protector Instructions Reference 15 Denso Protal 7200 Repair Cartridge Data Sheet Reference 16 Trenton EON 1000 GP Instructions Reference 17 Denso Protal 7125 Instructions Reference 18 Denso Protal 7200 Instructions Reference 19 Trenton Fill-Pro_PM-GP Reference 20 Trenton Wax Tape Systems Brochure Rev10 Reference 21 Denso-Glass-Outerwrap	De- cem- ber 1, 2014	Janu- ary 1, 2016
-------------------------	---	-------------------------------	-------------------------

<u>DAMG</u> <u>0</u>	Table of Contents DAMG 1: Inserted new section: 10. Emergency Locate Request at the Site of Train Derailment	Janu- ary 1, 2014	Janu- ary 1, 2016
---------------------------------------	--	-------------------------	-------------------------

<u>DAMG</u> <u>1</u>	Requirements 2. Types of Locate Requests 2. B. (1) Normal Locate Request 2. B. (1) (a): Added language to clarify what JULIE considers a business day. "A typical locate request where the excavator must provide advance notice of an excavation to JULIE a minimum of forty eight hours / two (2) business days (exclusive of Saturdays, Sundays, and holidays) prior the start of any excavation. Business day begins at 08:00 and ends at 16:00 (exclusive of Saturdays, Sundays, and holidays recognized by the State Wide One Call Notice System). Requests for locates received after 16:00 (4:00 pm) will be processed as if received at 08:00 on the next business day." 2. B. (1) (b): Added "including the day of the call". "The excavation work must start within fourteen (14) calendar days of the day of the locate request, including the day of the call or the ticket becomes invalid." 2. B. (1) (c): Revised clarify when an extension request is required.	De- cem- ber 1, 2014	Janu- ary 1, 2016
---------------------------------------	---	-------------------------------	-------------------------

"When the excavation project extends past twenty eight (28) days from the date of the original notice, the excavator MUST request an extension of the JULIE ticket between the twentieth (20th) and twenty eighth (28th) calendar day or the ticket becomes invalid and excavation work must cease after the expiration date on the JULIE ticket."

2. B. (2) Emergency Locate Request

2. B. (2) (f): Word change "may be" replaces "is" in the sentence "The excavator may be responsible for damage to un-marked facilities if excavation is started before the 2 hour wait time."

2. B. (3): Revised heading to Joint Meet Request from Joint Meet Locate since joint meet is not a locating session.

3. JULIE Notes

3. B.: Revised last sentence to clarify how JULIE processes calls received after 4:00 PM.

"The request will be processed as if received at 8 AM on the next business day."

3. D.: Revised to clarify that all new installed facilities are to be back flagged.

"Excavation damage prevention best practices have shown back flagging is effective to prevent 3rd party damage to newly installed facilities. All Ameren Illinois and Contractor crews are required to back flag all newly installed facilities. See MAIN 1 and SERV 1.

4. JULIE Ticket Transmittal

4. A. Locate Request Tickets

4. A. (2) (c): Word change, "message" replaces "call" in "Automated message is initiated to advise the excavator that Ameren's facility is clear of the proposed dig site."

4. A. (5) Difficult to locate facilities...

4. A. (5) (d): Added "requires an Emergency Locate Request" when Ameren has to hand dig to identify the location of a difficult to locate facility.

5. Damage Prevention Notification to Excavators and the General Public

5. E. Revised to: "Ameren Illinois distributes a letter along with a copy of JULIE's Farming Brochure to known field tiling contractors."

5. F.: Changed department designation to Ameren Illinois Communications/Public Relations Department from Corporate Communications.

5. G.: Removed the sentence "The excavator's name is added to the list of known excavators."

Ameren Illinois utilizes other means of identifying known excavators.

8. Excavating Near a Transmission, High Pressure Distribution, or 8" and Larger Steel Main

8. D. (2): Revised by adding language from the JULIE law regarding exposing buried facilities within the tolerance zone.

"As stated in the Illinois Underground Utility Facilities Damage Prevention Act (section 4(b)), the Excavator is required to plan the excavation or demolition to avoid or minimize interference with underground utility facilities within the tolerance zone by utilizing such precautions that include, but are not limited to, hand excavation, vacuum excavation methods, and visually inspecting the excavation while in progress until clear of the existing marked facility."

This was added to reinforce the requirement for exposing all buried facilities within the tolerance zone and that the facilities should remain exposed until the excavation, including boring operation, has cleared the facility. This is the language from Damage Prevention Act.

8. F. : Added "electronic equivalent", " A Buried Pipe Examination form, CORR 2.30, shall be completed within ClickMobile or electronic equivalent if the facility is exposed."

Damage Prevention Standby personnel do not utilize ClickMobile but have an electronic version on their laptops.

10. Emergency Locate Request at the Site of a Train Derailment - New section that was added

A. When there is locate request at the site of a railroad train derailment, the locator shall notify Ameren Illinois Damage Prevention personnel once it is determined there is a gas line in the vicinity of the derailment. If there is a gas line in the vicinity the Damage Prevention personnel or locator will notify local Gas Supervision.

B. If there is a gas odor in the area, locator shall call the Ameren Illinois Emergency number 1.800. 755.5000 to report a leak.

C. The Damage Prevention personnel and/or local qualified gas personnel should meet with the railroad representative and emergency response personnel. See EMER 2.04 9. Train Derailment near Pipeline Facilities.

This was added due to PHMSA advisory that was issued in February, 2013 advising pipeline owners of the importance of assuring that pipeline facilities have not be damaged by a railroad accident.

11. Facility Location Information

11. B.: New item added:

"Upon completion of gas projects, updates to AIC's electronic mapping system in G/Tech will be completed within 90 days from time the completed job packet is approved. See MAIN 1"

ICC requested Ameren to specify how soon the Company's electronic mapping would be updated.

13. Records

13. D.: Revised to: "Buried Pipe Examination forms completed prior to November 1 2014 shall be retained for the life of the facility. Beginning November 1, 2014 Buried Pipe Examination information is completed within ClickMobile and shall be maintained in Maximo for the life of the facility. Information from electronic equivalent will be maintained until procedures for entering into Maximo are available."

Electronic equivalent was added to cover Damage Prevention Standby personnel documentation procedures.

DAMG 2.01	<p>Reporting JULIE Violators</p> <p>2. Reportable Violations</p> <p>2. C.: Added Damage Prevention personnel, "A contractor or utility excavator, including Ameren, that violates the JULIE law and damages Ameren's facilities which results in a gas leak on a main, shall be reported to the Gas Supervisor and/or Damage Prevention personnel at the earliest practical moment."</p> <p>3. Investigation of Reportable Violations</p> <p>3. A.: Added Damage Prevention personnel, "Once a violation is reported, the Gas Supervisor and/or Damage Prevention personnel shall investigate and document the investigation on the Illinois Underground Utility Facilities Damage Prevention Act Incident Report and submit to the Damage Prevention Group."</p> <p>3. B. (8): Corrected the E-mail address to @Gas Julie Violation since the format of the DL was revised.</p> <p>4. Reporting a Suspected Violation</p> <p>4. A.: Added "or designee", "The Gas Supervisor or designee should send the Incident Report and supporting documents to the Damage Prevention Group (Mail Code P-10) within 20 days for all main hits resulting in a gas leak."</p>	<p>Janu- ary 1, 2014</p>	<p>Janu- ary 1, 2016</p>
EMER 0	<p>Table of Contents</p> <p>EMER 2.04 added</p> <p>7. Fire, Ignition, or Explosion - Non-Gas Related</p> <p>9. Train Derailment near Pipeline Facilities</p> <p>Forms and Reference Materials added</p> <p>Reference 02 - Electric Cold Load Restoration Policy</p>	<p>July 1, 2014</p>	<p>Janu- ary 1, 2016</p>

EMER 2.01	<p>Customer Contact Center</p> <p>4. Emergency Gas Calls</p> <p>4. H. Outside Odor, Hear or See</p> <p>4. H. (2): Call taker will now tell caller that they will contact a service person who usually arrives within 1 hour.</p> <p>Call Center had earlier changed the script to 60 minutes but callers were thinking the call taker was saying 16 minutes.</p>	<p>January 1, 2014</p>	<p>January 1, 2016</p>
EMER 2.02	<p>Dispatch Center</p> <p>3. Cold Weather Electrical Outages and Restoring Electrical Service</p> <p>3. A. (1): Revised to, "Ambient temperature: Normally temperature of 32°F or less"</p> <p>3. A. (3): Revised to, "Duration of the electrical outage: In excess of 2 hours"</p> <p>3. A.(4): Number and size of gas customers affected:</p> <p>Added (a) 300+ customers on a gas system identified as High Risk</p> <p>Added (b) 500+ customers on a gas system identified as Moderate Risk.</p> <p>SMR Team added these to provide more guidance for the Dispatchers.</p> <p>3. B. Completely revised how dispatch will handle these situations.</p> <p>B. "When determined by the Distribution System Operations Supervisor (DSOS) that an electric outage will exceed the thresholds identified in the Electric Cold Load Restoration Policy, See EMER 4, the DSOS will inform the appropriate Gas Technical Services (GTS) Supervisor and Gas Control of the electric outage. Electric restoration for the affected circuits will be coordinated with GTS, based on the risk level of the affected gas system listed in the ElectricColdLoadPickup.xlsx file. GTS should also be notified of outages involving Emergency Operation Center (EOC) activations due to such events as: flooding, storms, civil unrest, etc and scheduled maintenance outages."</p> <p>Updated the table listing the Gas Technical Services Supervisors and their contact information</p> <p>Gas Tech Services developed an Electric Cold Load Restoration Policy which better defines the interaction between electric and gas following a significant electrical outage where the affected gas system could be impacted with the restoration of electrical service.</p>	<p>July 1, 2013</p>	<p>January 1, 2016</p>

**EMER
2.04**

Gas Field Personnel

July 1,
2014

Janu-
ary 1,
2016

2. Inside Odor Compliant - Hazardous Condition

2. L.: Typo correction "EMER 2.04 5."

4. Major Leaks or Line Breaks

4. C.: Added "or designee", "Gas Supervisor or designee should contact Gas Control to determine or verify if affected gas system is being remotely monitored and advise them of situation and possible actions that may be taken."

4. D.: Added "or designee", "Gas Supervisor or designee should contact Gas Tech Services if transmission or high pressure distribution facilities are involved."

In many cases it is an OSA/OSR that will make the contacts not the Gas Supervisor.

5. Gas In A Sewer - Hazardous Condition

Revised, "When gas is detected in a "sanitary sewer", a reading greater than 30% LEL (1.5% gas-in-air) is considered a hazardous condition. The following steps should be taken:"

The change to 30% LEL was missed on the last update.

5. C.: Revised to, "If the Gas Supervisor/Gas Superintendent determines there may be a potential for isolating or shutting down a section/segment of the system, Gas Control should be contacted to verify if the affected system is remotely monitored. If Gas Control verifies they do remotely monitor the affected system, establish a line of communications for the purpose of:

- (1) Keeping them updated on status of situation
- (2) Requesting their assistance in monitoring
- (3) Determining at what point Gas Control should issue a warning of potential system problem
- (4) Notifying Gas Control when situation has been corrected and system should be back to normal operation. Verify that monitored operating parameters have been restored."

SMR Team felt the need to contact Gas Control was only necessary when there was a possibility of isolating or shutting down a section of the system. Gas Control felt the line of communication process should be the same for all situation thus the reason 5.C. (1) thru (4) was added.

6. Fire, Ignition or Explosion - Gas Related

6. C.: New inserted, "If transmission or high pressure distribution facility(s) is involved, Gas Supervisor should notify Gas Tech Services Supervisor."

6. D.: New inserted, "Depending on the extent of the situation, if the Gas Supervisor/Gas Superintendent determines there may be a potential for isolating or shutting down a section/seg-

UNCONTROLLED IF PRINTED

ment of the system, Gas Control should be contacted to verify if the affected system is remotely monitored. If Gas Control verifies they do remotely monitor the affected system, establish a line of communications for the purpose of:

- (1) Keeping them updated on status of situation
- (2) Requesting their assistance in monitoring
- (3) Determining at what point Gas Control should issue a warning of potential system problem
- (4) Notifying Gas Control when situation has been corrected and system should be back to normal operation. Verify that monitored operating parameters have been restored."

SMR Team felt the need to contact Gas Control was only necessary when there was a possibility of isolating or shutting down a section of the system. Gas Control felt the line of communication process should be the same for all situation thus the reason 6.D. (1) thru (4) was added.

6. F. (2): New inserted, "If the gas meter set can be safely approached, shut off and red pin the meter valve or disconnect and cap. Complete the OAS 6H screen."

6. F. (3): Revised to, If Fire Department has shut-off the valve, visually verify the valve is off, if possible, red pin the meter valve or disconnect and cap. Complete the OAS 6H screen."

SMR Team wanted to provide gas field personnel with more guidance on how they should handle situation where the fire department is on the scene.

7. Fire, Ignition or Explosion - Non-Gas Related - New Section

"When responding to a non-gas related fire, ignition or explosion our first priorities are public safety and employee safety. The following steps will outline the appropriate actions:

A. Evaluate the situation; determine if the fire, ignition or explosion has created an immediate hazard to life or property and if a gas facility is involved, main, service, meter set, or other gas facility.

B. Make contact with the Fire Chief or fireman in charge. Remember in a fire situation, the Fire Department has jurisdiction and is in charge of the scene.

(1) Ask if they have shut-off the gas meter valve? If not ask for permission to shut-off the valve, if gas service needs to be temporarily discontinued.

(2) If the gas meter set can be safely approached, shut off and red pin the meter valve or disconnect and cap. Complete OAS 6H screen.

(3) Check components for possible damage due to the fire. If there is any indication of damage, eliminate gas service to the damaged component to ensure that no gas can leak by or through that component. See INVE 2.01.

UNCONTROLLED IF PRINTED

C. If Fire Department has shut-off the valve visually verify the valve is off, if possible, red pin the meter valve or disconnect and cap. Complete OAS 6H screen.

D. If the information received indicates that natural gas was not involved in the cause of the fire, no further investigation is required. Within one business day, the gas field personnel should notify the Gas Supervisor that they responded to a fire."

SMR Team felt there should be procedures added when it is evident that gas was not the cause but there is a potential for the gas facilities to be impacted by the fire or explosion.

8. Explosion and/or Fire Near Gas Pipeline Facilities

8. I.: Grammatical only, Gas Tech Services" replaced "Gas Operations and Services".

8. J.: Grammatical only, Gas Tech Services" replaced "Gas Operations and Services".

8. K.: New inserted, "Depending on the extent of the situation, if the Gas Supervisor/Gas Superintendent/Gas Tech Service Supervisor determines there may be a potential for isolating or shutting down a section/segment of the system, Gas Control should be contacted to verify if the affected system is remotely monitored. If Gas Control verifies they do remotely monitor the affected system, establish a line of communications for the purpose of:

(1) Keeping them updated on status of situation

(2) Requesting their assistance in monitoring

(3) Determining at what point Gas Control should issue a warning of potential system problem

(4) Notifying Gas Control when situation has been corrected and system should be back to normal operation. Verify that monitored operating parameters have been restored"

SMR Team felt the need to contact Gas Control was only necessary when there was a possibility of isolating or shutting down a section of the system. Gas Control felt the line of communication process should be the same for all situation thus the reason 8.K. (1) thru (4) was added.

9. Train Derailment near Pipeline Facilities - New section

A. When notified of a train derailment, the Gas Supervisor should verify if pipeline facilities are located within the vicinity of the derailment.

B. When the pipeline facilities are located within the vicinity, provide pertinent information to rail operators and emergency response officials. Such information would include the presence, depth and location of the pipelines so that the movement of heavy equipment and debris on the right-of-way does not

damage or rupture the pipeline or otherwise pose a hazard to people working in, and around, the derailment.

C. Gas Supervisor should notify Ameren Illinois Pipeline Integrity group of the derailment.

This was added due to PHMSA advisory that was issued in February, 2013 advising pipeline owners of the importance of assuring that pipeline facilities have not be damaged by a railroad accident.

10. Low Pressure Situation

10. F.: Revised to, "Gas Supervisor should notify Gas Control of the situation and advise them of any assistance that may be needed or could be provided with the affected system(s). If Gas Control verifies they do remotely monitor the affected system, establish a line of communications for the purpose of:

- (1) Keeping them updated on status of situation
- (2) Requesting their assistance in monitoring
- (3) Determining at what point Gas Control should issue a warning of potential system problem
- (4) Notifying Gas Control when situation has been corrected and system should be back to normal operation. Verify that monitored operating parameters have been restored"

Gas Control felt the line of communication process should be the same for all situation thus the reason 10.F. (1) thru (4) was added.

11. High Pressure Situation

11. E.: Revised to, "Gas Supervisor should notify Gas Control of the situation and advise them on any assistance that may be needed or could be provided with the affected system(s). If Gas Control verifies they do remotely monitor the affected system, establish a line of communications for the purpose of:

- (1) Keeping them updated on status of situation
- (2) Requesting their assistance in monitoring
- (3) Determining at what point Gas Control should issue a warning of potential system problem
- (4) Notifying Gas Control when situation has been corrected and system should be back to normal operation. Verify that monitored operating parameters have been restored

Gas Control felt the line of communication process should be the same for all situation thus the reason 11.E. (1) thru (4) was added.

11. F.: Grammatical only, Gas Tech Services" replaced "Gas Operations and Services".

11. K.: Grammatical only, job title update to "Manager, Gas Compliance & Training".

UNCONTROLLED IF PRINTED

12. Loss and Restoration of Service

12. B.: Revised to, "Gas Supervisor/Gas Superintendent should contact Gas Control to determine or verify if the affected system or adjacent systems are remotely monitored, notify them of the situation and discuss assistance Gas Control may be able to provide with monitoring operating parameters of the affected and adjacent systems. A line of communications should be established for the purpose of:

- (1) Keeping them updated on status of situation
- (2) Requesting their assistance in monitoring
- (3) Determining at what point Gas Control should issue a warning of potential system problem
- (4) Notifying Gas Control when situation has been corrected and system should be back to normal operation. Verify that monitored operating parameters have been restored"

Gas Control felt the line of communication process should be the same for all situation thus the reason 12.B. (1) thru (4) was added.

12. F. (3): Grammatical change only, "Gas Tech Services" replaced "Gas Operations and Services".

12. K. Organize the work force

12. K. (2): New inserted, "The Gas Supervisor or designee will maintain the customer record at the assigned headquarters."

12. K. (3): New inserted, "The Gas Supervisor or designee should utilize the customer record (obtained from the DDC/PDC) to cross reference all customer turned off and turned on from the Emergency Gas Meter Status Report form (Stock Code 37 22 247)"

12. K. (5): Revised to, "Assign 5 to 10 gas field personnel and a Gas Supervisor to each area. Each supervisor will be given maps for the affected area. Gas field personnel should be assigned designated streets/area to turn off and record the information on the Emergency Gas Meter Status Record form."

SMR Team added these to provide a little more guidance and the Gas Superintendents wanted to add the use of the Emergency Gas Meter Status Record.

12. L. Turn-off requirement for an outage

12. L. (2): Revised to, "Record the address and meter number on the Emergency Gas Meter Status Record form."

12. S. Turn-on requirements for an outage

12. S. (9): Revised to, "Gas field personnel should record, at a minimum, the customer address, meter number, times, and dates of service restoration. This information shall be added to the Emergency Gas Meter Status Record form and given to the Gas Supervisor or designee for cross reference with the

customer records to assure that all customers have been turned back on."

Revise to incorporate the use of the Emergency Gas Meter Status Record.

EMER 2.05	<p>Natural Disasters or Civil Disobedience</p> <p>2. Natural Disasters</p> <p>2. A.: Revised to, "Gas Supervisor should contact Gas Control to advise them of the situation and to determine if the affected system(s) is remotely monitored. If Gas Control verifies they do remotely monitor the affected system(s), establish a line of communications for the purpose of:</p> <p>(1) Keeping them updated on status of situation</p> <p>(2) Requesting their assistance in monitoring</p> <p>(3) Determining at what point Gas Control should issue a warning of potential system problem</p> <p>(4) Notifying Gas Control when situation has been corrected and system should be back to normal operation. Verify that monitored operating parameters have been restored."</p> <p>Gas Control felt the line of communication process should be the same for all situation thus the reason 2.A. (1) thru (4) was added.</p> <p>2. B.: Grammatical only "Gas Tech Services" replaced "Gas Operations and Services".</p>	July 1, 2014	Janu- ary 1, 2016
EMER 4	<p>Forms and Reference Materials</p> <p>Added:</p> <p>Reference 02 - Electric Cold Load Restoration Policy</p>	Janu- ary 1, 2013	Janu- ary 1, 2016
EXCV 0	<p>Table of Contents</p> <p>Forms and Reference Materials</p> <p>Removed Excavation/Soils Checklist and Gas Job Briefing Form</p>	Janu- ary 1, 2011	Janu- ary 1, 2016
EXCV 2.04	<p>Soil Analysis & Classification</p> <p>6. Excavation/Soils Checklist</p> <p>6. E.: New "The Ameren Illinois Safety Department developed the Excavation/Soils Checklist and maintains an electronic copy of the most current version on the Ameren Illinois Safety SharePoint site under Policies, Procedures, & Forms, Safety Forms."</p> <p>Ameren Illinois Safety is the owner of this form and maintains the most current version on their SharePoint site. Therefore, to</p>	Janu- ary 1, 2014	Janu- ary 1, 2016

eliminate the need for update our O&M every time the form is updated, the O&M now references Safety's SharePoint site.

EXCV 2.09	<p>Working in Hazardous Atmosphere</p> <p>3. Entering Excavation</p> <p>3. A.: Revised to "The atmosphere of the excavation shall be tested with a gas detection instrument to determine the amount of combustible gases present and the oxygen level. If there is a possible source or indication of toxic gasses such as carbon monoxide or hydrogen sulfide, the atmosphere should be tested for the specific gas(s) prior to allowing anyone to enter."</p> <p>In most cases checking atmosphere for combustible gas and oxygen deficiency with a gas detection instrument is sufficient. However, additional testing may be required if there is suspicion that other toxic gas(s) is present.</p> <p>3. F.: Revised the fire extinguisher to a 20 pound (A, B, C) dry chemical fire extinguisher instead of a 20 pound ABC or BC dry chemical.</p>	<p>Janu- ary 1, 2014</p>	<p>Janu- ary 1, 2016</p>
EXCV 4	<p>Forms and Reference Materials</p> <p>Removed Excavation/Soils Checklist and Gas Job Briefing Form</p> <p>Ameren Illinois Safety is the owner of these forms and maintains the most current version on their SharePoint site. Therefore, to eliminate the need for update our O&M every time these forms are updated, the O&M now references Safety's SharePoint site.</p>	<p>Janu- ary 1, 2011</p>	<p>Janu- ary 1, 2016</p>
<u>GLOS</u>	<p>Glossary</p> <p>Revised:</p> <p>Coupling</p> <p>Farm Tap</p> <p>Regulator Station</p> <p>Service Line</p>	<p>De- cem- ber 1, 2014</p>	<p>Janu- ary 1, 2016</p>
<u>INCD</u> 1	<p>Incident Reporting</p> <p>1. B.: Added "gas storage", "A natural gas incident involves the release of gas on Ameren Illinois distribution, transmission, and gas storage facilities."</p> <p>2. Natural Gas Incident</p> <p>2. A. (4): Grammatical only, "million cubic feet" replaced "MCF".</p> <p>3. Potential Significant Events</p>	<p>Janu- ary 1, 2014</p>	<p>Janu- ary 1, 2016</p>

3. D.: New inserted, "Additionally, PHMSA requests that any suspected natural gas explosion be reported even though Ameren Illinois' facilities were not involved."

4. Courtesy Notification

4. A. (1): Grammatical only added "and/or" for "and", "Fire and/or Police Emergency Response to a release of natural gas from an Ameren Illinois facility where gas migration requires any of the following:"

6. Reporting

6. A. and 6. C. The previous 2 hour call has now been reduced to 1 hour from time of confirmed discovery based on proposed PHMSA's rule change.

6. A. "The Gas Supervisor shall contact Gas Compliance (see contact list below) at the earliest practical moment, not to exceed one (1) hour, following the confirmed discovery of a natural gas incident or event that may warrant a courtesy notification."

6. C. "Any required telephone reporting must be made within one (1) hour of confirmed discovery of the natural gas incident. The telephone reporting requirement is on a twenty four (24) hours a day, seven (7) days a week basis."

PHMSA is in the process of changing the 2 hour notification time to 1 hour as mandated in the Pipeline Safety Act.

7. Gas Compliance Contact List

Added Mike Fuller and his contact information

8. Reporting Matrix

8. A. Gas Compliance shall be contacted when any of the following occurred:

8. A. Revised table heading to "Report within 1 hour of confirmed discovery".

Item 4 in table "million cubic feet" replaced "MCF"

Item 11 was added "Additionally, PHMSA requests that any suspected natural gas explosion be reported even though Ameren Illinois' facilities were not involved."

8. B. Gas Compliance shall make the following reporting contacts:

8. B. Revised table heading to "Report within 1 hour of confirmed discovery".

Grammatical only "million cubic feet" replaced "MCF"

Added ""Additionally, PHMSA requests that any suspected natural gas explosion be reported even though Ameren Illinois' facilities were not involved." This get reported to ICC and PHMSA.

11. Ameren Illinois Communication Notification

Updated Tucker Kennedy's cell phone and Media Hot Line phone number

12. Regulatory Affairs Notification

Brice Sheriff contact information replaces Jackie Voiles

13 Post-Incident Alcohol and Drug Testing

13. B. (2) Grammatical only "incident" replaced "accident"

13. C. Updated CCM contact information, "CCM at 314-963-3403 during normal work hours or 800-619-1122 after hours."

INCD
4

Forms and Reference Materials

January 1, 2014 January 1, 2016

Updated forms

Form 01- PHMSA Incident Report - Gas Distribution System (Rev 10-2014)

Form 02 - PHMSA Incident Report - Gas Transmission and Gathering Pipeline Systems (Rev 10-2014)

Form 03 - Potential Incident Report Form

INVE 0

Table of Contents

January 1, 2013 January 1, 2016

INVE 2.01 Removed Report of Investigation

INVE 1

Investigation of Incidents

May 1, 2010 January 1, 2016

2. D. Grammatical only, "unless" replaced "or".

"Every effort should be made to preserve the incident site and existing gas facilities, if at all possible, until after the investigation is complete unless:"

2. D. (1): Grammatical only added "or"

"The authorities having jurisdiction over the investigation have determined natural gas was not a contributing factor to the incident or"

2. F.: Revised to "Gas facilities that may have failed must be preserved and kept in a secured location until Corporate Claims specifies a location where facilities can be analyzed."

Added Corporate Claims who will specify who will analyze the gas equipment.

INVE
2.01

Incident Investigation

January 1, 2013 January 1, 2016

2. Investigation Documentation

2. A. : Revised to, "Limit the number of qualified gas field personnel and management required to perform the investigation. Warn all individuals not to take photos or videos of the scene."

2. B.: New inserted, "One individual should be designated to take photos and document the investigation."

2. E.: Relocated from 2. N, "Document only the facts, not opinions!"

Corporate Claims wants only one set of photos and one investigation report associated with an investigation.

3. Investigation of Ameren Illinois Facilities

"3. G.: Revised to "Test the gas service at the operating pressure if required by the State or Federal Authorities."

Clarifies testing at normal operating pressure of the service line not at the pressure a new service line would be tested.

4. Chain of Custody Documentation

4. C.: Added the stock code for the Chain of Custody Tag, 16 01 638.

INVE 2.02

Investigation of Fires

1. B. Grammatical only, Added "The", "The Fire Chief or Fireman in-charge at the scene has jurisdiction and is in charge of the scene."

2. Fire, Ignition or Explosion Investigation

"2. B.: Revised to reflect the 1 hour reporting time, "Fires and explosions involving natural gas are generally reportable within one (1) hour of the confirmed discovery of a natural gas incident to the (ICC) and to PHMSA. See the reporting matrix in INCD 1."

4. Communication with the Public

4 A.: Revised format to a list, "When investigating incidents involving natural gas, gas field personnel and supervisors:

- (1) Shall be courteous and helpful to the public
- (2) Shall not divulge information regarding the cause of the incident, or the results of our investigation.
- (3) Shall not speculate as to the cause of the incident or pass on information that they have heard or gathered from others at the scene."

Removed the section "Engagement of Outside Entities to Assist with the Investigation". Corporate Claims will be the ones that would be responsible for this function.

April 1, 2013 January 1, 2016

INVE 4

Forms and Reference Materials

Updated Form 01 - Gas Investigation Log (January 1, 2016)

Added Photographer's Name

Removed the Employee Log

April 1, 2013 January 1, 2016

LEAK 0	<p>Table of Contents</p> <p>LEAK 2.08 Revised the following:</p> <p>2. Flame Ionization Instrument - Portable</p> <p>5. Gas-Trac</p>	De- cem- ber 1, 2014	Janu- ary 1, 2016
LEAK 2.01	<p>Indoor Leak Investigation</p> <p>5. Customer Not Home or Can't Get Into Structure</p> <p>5. F. If gas is detected inside of structure</p> <p>5. F. (1): Revised to "Shut-off gas at meter valve and Red Pin or disconnect the service line."</p> <p>SMR Team wanted to clarify that service needs either locked at the meter valve or disconnected so that the customer could not turn it back on with the leak investigation being completed.</p> <p>6. Leaks on Customer Facilities</p> <p>6. A. Inside gas leak on customer facilities</p> <p>6. A. (2) (a): Revised to, "Isolate the gas leak at the appliance control valve, customer owned valve, meter valve or outlet of meter set. If isolated at the meter valve lock the meter valve closed."</p> <p>SMR Team added other options for isolating customer's facilities.</p> <p>6. B. (1) & (2): Revised to,</p> <p>(1) "The customer can immediately call a qualified plumbing or heating professional to make the repair and the Company will turn the leak over to them once they arrive. In the case of a commercial/industrial process that has their own in-house maintenance personnel, the Company will turn the leak over to the customer if maintenance personnel are immediately on-site or</p> <p>(2) Isolate the appliance or piping, complete the OAS 6H screen and issue a Warning Tag. See TURN 2.11 Warning Tag.</p> <p>SMR Team added the word "or" at the end of (1) to emphasis the customer as an option. Added isolating the appliance or piping when the Warning Tag is issued.</p>	Janu- ary 1, 2013	Janu- ary 1, 2016
LEAK 2.02	<p>Outdoor Leak Investigation</p> <p>8. Leaks on Customer Owned Facilities</p> <p>8. A. If a gas leak is discovered on a customer-owned buried fuel line or an above ground outdoor fuel line that is of a hazardous nature.</p>	De- cem- ber 1, 2014	Janu- ary 1, 2016

8. A. (3): Revised to, "Isolate the gas leak at a customer owned valve, meter valve or outlet of meter set. If customer is not at home shut-off and "Red Pin" the outside meter valve."

SMR Team added other options for isolating customer's facilities.

8. A. (4): Revised to, "Notify customer of the gas leak and advise customer they are responsible for making the repairs. Complete the OAS 6H screen, "Red Pin", and issue a Warning Tag, See TURN 2.11 Warning Tag."

Clarify the OAS 6H screen should indicate meter valve was Red Pin.

8. B. (1) & (2): Revised to,

(1) "The customer can immediately call a qualified plumbing or heating professional to make the repair and the Company will turn the leak over to them once they arrive. In the case of a commercial/industrial process that has their own in-house maintenance personnel, the Company will turn the leak over to the customer if maintenance personnel are immediately on-site or

(2) Isolate customer piping, complete the OAS 6H screen and issue a Warning Tag. See TURN 2.11 Warning Tag.

SMR Team added the word "or" at the end of (1) to emphasize the customer as an option. Added isolating customer piping when the Warning Tag is issued.

**LEAK
2.06**

Leak Process Flow Charts

The below grade leak classification process flow chart has been revised to reflect change in leak classification when gas is detected in a valve box. If the gas reading is 80% LEL or greater in a valve box it will be classified as a Grade 2 Leak. If the gas reading is less than 80% LEL in a valve box it will be classified as a Grade 3 Leak. Valve box was separated from other below grade structures: storm sewer, water meter box, utility pedestal, pit/vault, or vent pipe.

Revision is consistent with GPTC guidelines on how to comply with the Pipeline Safety Code, PHMSA's Part 192.

De-
cem-
ber 1,
2014

Janu-
ary 1,
2016

**LEAK
2.08**

Leak Surveys - Equipment

2. Flame Ionization Instrument - Portable

Former 2. D: Deleted the sentence on adjusting audible alarm since each instrument is different.

2. F.: Revised address daily operational check, "A daily operational check should be performed prior to beginning the survey in accordance with manufacturer's operating instructions or recommendations. See LEAK 4. If FI unit is being utilized on daily basis for leak survey activity, the unit should be checked

De-
cem-
ber 1,
2014

Janu-
ary 1,
2016

with the 50 ppm test/bump gas at the conclusion of the day's activity to verify the unit's sensor is responsive."

3. Gas Detection Instrument

3. B.: Add reference to GLOS for definition of Gas Detection Instrument.

3. E.: Added "CGI's sensors" to clarify what is to be inspected and calibrated. "Instrument's CGI sensors, such as LEL, Gas, and CO, shall be inspected and calibrated on a monthly basis and recorded in Maximo."

3. F.: Inserted new item:

"In the "tick" mode this instrument can be used for pin-pointing an above ground leak or providing an indication that a combustible gas may be present."

SMR team wanted to add this to clarify the instrument can be used to pin-point an above grade leak. Still would require leak detection fluid to classify the leak.

3. H.: Revised to clarify daily operational check with a 50 ppm test gas if the instrument is being used for leak surveying.

"If, according to the manufacturer, the instrument is designed to function as a leak surveying instrument, then the individual(s) performing leak surveys will follow the manufacturer's operating instructions. Daily operational check with the 50 ppm test/bump gas should be performed prior to beginning the survey in accordance with manufacturer's operating instructions or recommendations See LEAK 4 If instrument is being utilized on daily basis for leak survey activity, the unit should be checked with the 50 ppm test/bump gas at the conclusion of the day's activity to verify the unit's sensor is responsive."

5. Gas-Trac - Removed "CGI in "tick"mode"

Moved the CGI in "tick mode" up into the Gas Detection Instrument section.

5. A.: Grammatical revision by starting sentence off with "May be used for inside meter leak survey since FI unit is not to be used inside."

5. B.: Grammatical revision by starting sentence off with "Can be used in conjunction with leak detection fluid."

5. C.: Revised the monthly calibration by referencing manufacturer's instructions, deleting the 2-1/2% methane gas, and adding the calibration are recorded in Maximo

5. F.: Word correction only, "in" replaces "as".

"This instrument cannot be used in an initial gas leak investigation or in classifying a gas leak."

**LEAK
2.09**

Leak Surveys - Walking Leak Survey

De-
cem-
ber 1,
2014

Janu-
ary 1,
2016

1. Walking Leak Survey

1. D.: Revised to; "In areas with vegetative cover the leak survey should follow, as close as possible, along the route of the gas main and/or service. At a minimum, the following items should be sampled when readily observed and are within one (1) to two (2) steps either side of the route."

Training group felt there needed the leak surveyors needed some guidance on when a catch basin, manhole, or pit type facility should be checked as they walked the survey route. Training group does address this during the OQ testing for leak surveyors.

1. K. Fenced Gas Facilities Inspected Annually or Monthly

Added "or Monthly" to the title.

1. K. (2): Revised by adding "monthly", "Fenced gas facilities that are inspected annually or monthly by Gas Tech Service will have all piping, below and above grade, inside the fenced area leak surveyed during the annual or monthly inspection and documented within ClickMobile on the Regulator Station Inspection Task."

1. K. (3): Revised to clarify the documentation of leak survey of fenced facilities associated with a Transmission Leak Survey.

(1) "Fenced gas facilities associated with transmission surveys that are located in a Class 3 location will be surveyed twice each calendar year not to exceed 7-1/2 months. The first inspection will be performed during their annual inspection and will be documented within ClickMobile on the Regulator Station Inspection Task. The second inspection will be documented within ClickMobile under on their own designated Leak Survey Task. These leak surveys will be performed by Gas Tech Service personnel."

Clarification by the Compliance personnel responsible for the GCAM program.

1. L. Fenced Gas Facilities Not Inspected Annually

1. L. (2) Fenced gas facilities could include but not limited to"

(a) Valve Station

(b) Large Meter set

Deleted "odorizer" and "pipeline take point" since they are inspected either annually or monthly.

1. N. (1) (f): Deleted reference to Gas Leak Case Field Report since it was eliminated with implementation of Click Mobile.

**LEAK
2.13**

Calibration of Gas Detection Instruments

De-
cem-
ber 1,
2016

Janu-
ary 1,
2016

2. Combustible Gas Indicator (CGI)

	<p>2. D. (4): Added "test gas"; "The instrument is then connected to line gas (system gas) or test gas."</p> <p>3. FI Monthly Calibration</p> <p>3. B.: Removed the step by step instructions 3. B. thru 3. H. and replaced by "Follow the calibration instructions in the instrument's operating manual. See LEAK 4"</p> <p>Existing language was only applicable to the Southern Cross FI unit.</p> <p>4. Gas Detection Instrument</p> <p>4. A.: Revised to "The CGI portion of the instrument shall be calibrated in accordance with the instructions under 2. above."</p> <p>4. B.: Revised to "Electronic instruments that have PPM sensors capable of detecting gas concentration of 50 PPM should be tested with 50 PPM methane gas/bump gas similar to that used for the FI unit."</p> <p>Instrument instructions do not contain procedure for calibrating the ppm sensor. Instructions only require checking with 50 ppm methane test/bump gas to ensure it is reacting. Calibration of the other sensors is addressed under CGI Calibration.</p>	ber 1, 2014	
LEAK 2.14	<p>Leak Surveys - Special Distribution Leak Survey</p> <p>4. Repairs</p> <p>4. E.: Added a sentence "The fitting and/or piping may be sent to a third party laboratory for a failure analysis investigation then returned to the Gas Training Center for retention."</p> <p>This covers what is typically done with many of the failed items where the cause of the failure cannot be readily determined.</p>	De- cem- ber 1, 2014	Janu- ary 1, 2016
<u>LEAK 4</u>	<p>Forms and Reference Materials</p> <p>Update:</p> <p>Reference 01 - Sensit Gold CGI Instruction Manual Rev 09_2010</p> <p>Replaces the 11_2006 manual</p>	De- cem- ber 1, 2014	Janu- ary 1, 2016
LOCT 0	<p>Table of Contents</p> <p>Reference Materials:</p> <p>Added Reference 30 - Heath Sure Lock All Pro User's Manual</p>	Janu- ary 1, 2014	Janu- ary 1, 2016
LOCT 2.02	<p>Equipment</p> <p>2.: Added Heath Sure Lock to the table of instruments.</p>	Janu- ary 1, 2014	Janu- ary 1, 2016
LOCT 4	<p>Forms and Reference Materials</p> <p>Added Reference 30 - Heath Sure Lock All Pro User's Manual</p>	Janu- ary 1, 2014	Janu- ary 1, 2016

UNCONTROLLED IF PRINTED

MAIN 0	<p>Table of Contents</p> <p>MAIN 1 added</p> <p>20. Records</p> <p>Added MAIN 2.06 Insertion</p>	<p>Janu- ary 1, 2011</p>	<p>Janu- ary 1, 2016</p>
<u>MAIN 1</u>	<p>Requirements</p> <p>1. B. New, "The term "main" in this section refers to distribu- tion, high pressure distribution or transmission mains and pipelines."</p> <p>Added so the term "main" could be used interchangeable with main or pipeline.</p> <p>14. Pigging</p> <p>14. A.: Revised to:" If the internal condition of the new or re- placement pipe cannot be visually inspected for debris or cleanliness, consideration should be given to pigging the pipe segment(s) prior to tying into existing mains."</p> <p>14. B.: New "Coiled plastic pipe that has been capped or plugged prior to installation does not need to be pigged unless a condition encountered during installation resulted in contami- nates entering the pipe."</p> <p>SMR Team clarified when pigging should be considered.</p> <p>15. Pressure Testing</p> <p>15. A.: Grammatical "relocated" replaces "reinstated" and "nat- ural gas" was added as a test medium.</p> <p>15. B.: New "The pressure testing which establishes the MAOP should be performed after construction is complete with the main in its final resting location"</p> <p>There is potential of the pipe and/or joints could be over- stressed as the pipe is moved into its final location. This re- quirement is contained in ASME B31.8 Code which is the pre- decessor to Part 192 Code.</p> <p>15. C.: New: Short sections of main for repair or replacement (i.e. typically a double random length approximately 40 to 45 feet or shorter) which cannot be practically tested after installa- tion may be pretested to the appropriate MAOP prior to instal- lation. The tie-in connection shall be leak tested at normal op- erating pressure."</p> <p>Addresses pretesting short section of pipe used for repair or replacement. SMR Team defined what is considered short sec- tion of pipe.</p> <p>19. Back-Flagging</p> <p>19. A.: Word change "are" replaced "should", Newly construct- ed Ameren Illinois gas facilities are to be "back-flagged" in ar-</p>	<p>Janu- ary 1, 2014</p>	<p>Janu- ary 1, 2016</p>

eas where the additional construction activity by others could potentially damage the new facilities.

19. B.: Revised to ""Yellow" locating flags, yellow headed stakes and/or yellow marking paint should be placed over the new facilities. There should be placement of enough flags/ stakes to ensure that Ameren Illinois gas facilities are clearly identified as to route and location."

Added yellow headed stakes and yellow marking paint as other methods for back-flagging. Damage Prevention group felt all newly installed facilities should be back-flagged.

Removed the former 19. C. thru 19. E. which addressed; special areas of concern, exempted heavily paved areas and gas supervisor's determining where back-flagging is needed.

20. Records - New section

20. A.: New, relocated or replaced gas mains shall be recorded on AIC's electronic mapping system in G/Tech within ninety (90) days from the time the job has been completed and/or placed in Status 70 in DOJM.

1) Division operations or Gas Tech Engineering should review and approve the completed job packet with in thirty (30) days from the time the job is complete and/or move to Status 70 in DOJM.

2) The electronic mapping should be updated within forty five (45) days of receipt of completed job packet and/or moved to Status 80 in DOJM.

This is the commitment made in response to ICC's request that the O&M state how soon Ameren Illinois' maps are updated.

**MAIN
2.04**

Temporary Support
2. Support Selection

April
1,
2010 Janu-
ary 1,
2016

Table: Revised the Plastic Pipe information. For 1-1/4" thru 4" no support required for spans 5 feet or less. For 6" and 8" no support required for spans of 5 feet to 10 feet. Revision was made based on information from Performance Pipe.

**MAIN
2.06**

Insertion
Totally new section that was prepared by the Gas Standards Committee and reviewed by a SMR Team. This section covers:
General
Considerations
Planning
Tracer Wire Installation
Insertion Procedures

Janu-
ary 1,
2016

Conduit or Sleeve Insertion Procedures

MAIN 3.03	<p>Lateral Tap, PE, TDW Side Tap</p> <p>Added stock codes for the TDW Shortstop and Valve Combos; 4" x 4", 6' x 4", 8" x 4"</p>	<p>April 1, 2013</p>	<p>Janu- ary 1, 2016</p>
METR 0	<p>Table of Contents</p> <p>METR 2.23 Gas Meter Exchange</p> <p>Revise 10. Meter Exchange Using Portable CNG Grunsky Ap- paratus</p> <p>Added:</p> <p>11. Post Card 1</p> <p>12. Post Card 2</p> <p>13. Letter 3</p> <p>METR 2.25</p> <p>Changed 3. Pressure and Temperature Transmitter Inspection</p> <p>METR 4 Forms and Reference Materials</p> <p>Revised Form 03 - Gas Meter Data Sheet</p> <p>Added Form 05 - Electronic Corrector Verification</p> <p>Added:</p> <p>Reference 10 - Grunsky Gas Meter Quick Change Equipment</p> <p>Reference 11 - Actaris Itron B31 Series Regulator</p> <p>Reference 12 - Actaris Itron B34 Series Regulator</p> <p>Reference 13 - Actaris Itron B42 Series Regulator</p> <p>Reference 14 - Actaris Itron CL34 Series Regulator</p> <p>Reference 15 - Actaris Itron CL31 Series Commercial Regula- tor</p> <p>Reference 16 - Fisher CS800 Series Bulletin</p> <p>Reference 17 - Fisher 299H Bulletin</p> <p>Reference 18 - Fisher CS400 Series Bulletin</p>	<p>Janu- ary 1, 2014</p>	<p>Janu- ary 1, 2016</p>
METR 2.16	<p>Gas Meter Data Sheet</p> <p>The Gas Meter Data Sheet (GMDS) has been updated to in- clude additional information that needs to be provided.</p> <p>3. Distribution</p> <p>3. B.: Additional copy the Gas Meter Data Sheet will now only be sent to CAD. Eliminated sending one to End User Trans- portation for gas transportation customer.</p> <p>4. Completion Instructions</p>	<p>Janu- ary 1, 2013</p>	<p>Janu- ary 1, 2016</p>

Revision were made to address additional information that is now being required.

**METR
2.22**

Pressure Gauges

De-
cem-
ber 1,
2014

Janu-
ary 1,
2016

1. B.: Revised to "Certain activities require a specific type of pressure gauge to be utilized to ensure an adequate degree of accuracy."

1. C.: Revised to "This procedure identifies when a test gauge or better shall be utilized and the requirements for periodically verifying the accuracy of the test gauge and a calibrating gauge.

2. Ameren Illinois Gauge Definition

2. A.: Industrial/Commercial Gauge - . The industrial/commercial gauge has accuracy less than $\pm 0.5\%$ full scale. They are not to be used to set pressures, verify pressure settings, or record pressures used to establish or validate a MAOP. These gauges can be utilized in locations or situations where only indication of the approximate pressure or presence of pressure is necessary, i.e. check for loss of pressure due to a leak, check for pressure at tapping/stopping operation, regulator station equipped with remote monitoring or at location to ensure there is not an inadvertent loss of gas service.

Definition of industrial/commercial gauge was added to clarify the difference from a process gauge. Emphasized that an industrial/commercial gauge is not to be used to set or verify set pressures nor establish or validate MAOP.

2. B. Process Gauge - A higher quality pressure gauge with an accuracy of $\pm 0.5\%$ full scale, ASME Grade 2A. These gauges are utilized for continuously monitoring gas pressure on system or used to perform a leak and/or strength test to establish system MAOP. A process gauge is typically installed at a location where an accurate pressure value is necessary, i.e. a regulator station or meter set. Process gauges used to verify the gas facilities' MAOP are addressed in PTST 1 Pressure Testing Requirements.

Added the reference to ASME Grade 2A and referred to PTST 1 for process gauges used to establish or validate MAOP.

2. C. Test Gauge - A designated pressure gauge, ASME Grade 2A or 3A, with accuracy of at least $\pm 0.5\%$ full scale that is periodically verified for accuracy and utilized for activities that require reading accuracy. A spring test gauge usually has features such as a definitive zero, mirrored scale, knife-edged pointer, and a serial number. Test Gauge is normally printed on the face of a spring test gauge. A digital gauge that meets the minimum accuracy requirement can be used in lieu of a spring test gauge. Test gauges are entered and maintained in Maximo. Spring test gauges are shown in Specialized Tools and Equipment in Gas Operations and Services SharePoint site."

Added the reference to ASME Grade 2A or 3A and that spring test gauges will have Test Gauge printed on the face and will have a serial number. Digital gauges that meet the $\pm 0.5\%$ full scale accuracy can be used as test gauge.

2. D. Calibrating Gauge - A pressure gauge with an accuracy of at least $\pm 0.10\%$ full scale, Grade 4A, utilized primarily for verifying the accuracy of a test gauge or calibrating a test gauge in a shop environment. A calibrating test gauge can also be utilized in the field to verify the accuracy of an electronic pressure correcting device, calibrating pressure transducers, or in other situations where a high degree of accuracy is required. A calibrating gauge is typically a digital gauge with a full-scale accuracy range of $\pm 0.10\%$ or better, i.e Crystal XP2i, Druck DPI 800/802

Corrected the gauge type by removing "Test" and added reference to ASME Grade 4A. Added examples of digital calibrating gauges that are used in Ameren Illinois mostly by the Gas Tech Services technicians.

3. Use of Test Gauges

3. A.: Revised to "A test gauge shall be used when performing the following activities. Gauges should be "zeroed" prior to exposing them to the gas pressure. A calibrating gauge can also be used to perform these functions."

5. Approved Test Gauges

Revised to "A list of approved spring test gauges can be found in the Specialized Tools and Equipment section of the Gas Operations and Services SharePoint site."

6. Verification and Calibration

6. A. (7): New "Digital test gauge will be calibrated in same manner as Calibrating Gauge shown below."

6. B. Calibrating Gauge

6. B. (2): Revised to "The calibrating gauge may be sent to a third party for the annual calibration or may be sent to a GTS Gas Control Technician listed below:

Replaced sending gauges to Decatur Meter Shop with sending to a Gas Control Technician. A shipping address is provide for the Gas Control Technician assigned in each Division.

METR 2.23

Gas Meter Exchanges

10 Meter Exchanges Using Portable CNG Grunsky Apparatus - Added the Grunsky Apparatus used in Springfield.

10. B.: New, "Prior to touching the gas meter set, check the meter set for voltage with a volt stick."

10. C.: New, "Exchanges should be done with little or no load present if possible, such as a furnace in operation. If furnace is

Janu-
ary 1,
2014

Janu-
ary 1,
2016

in operation, consider waiting for it to cycle off to conserve CNG tank pressure."

10. D. (1): Increased CNG tank pressure to 600 psig from 500 psig.

10. D. (2): New, "The tee must be in proper alignment for the CNG system to work."

10. D. (7): New, "Remove plug by squeezing the bag and grasping plug, loosen with fingers and let plug drop into bag."

10. D. (8): New, "Force proper size bayonet into pipe through tee locking with a twisting motion. No gas should be coming from the bag purge cap signifying a good seal."

10. D. (11): Added meter header inspection, "Follow the procedures for exchanging the meter and meter header inspection. See METR 2.20 Meter Header Inspection

10. D. (15): Revised to "Insert plug into tee and snugly tighten by hand. The bag will remain on the tee while replacing the plug into the tee."

10. D. (17): Revised to "Back off the plug in the tee, do not remove, apply pipe dope to the plug and tighten with a wrench."

10. D. (18): Added "leak detection solution", "Check for leakage with leak detection solution."

10. D. (19): Added "Clean fittings", "Clean fittings and paint meter set

10. D. (2): New, "Observe meter index movement to see if meter has returned to normal operation, when compared to beginning the meter exchange."

Personnel from the Gas Training Center and Springfield Operations reviewed and modified the instructions for using Grunsky system.

METR 2.25

Ultrasonic Meter Testing

July 1, 2014

January 1, 2016

2. Ultrasonic Meter Inspection Schedule

2. A.: Revise the testing interval to, "Each ultrasonic meter installed at a customer meter installation shall be inspected and interrogated using manufacturer's software to verify instrument overall operating condition at least every three (3) months."

This is a requirement of ICC Part 501.

3. Pressure and Temperature Transmitter Inspection

Replaced "Inspection" for Calibration"

METR 2.27

Electronic Corrector Verification

January 1, 2016

This is a totally new section that has been added by the Gas Metering Committee. Section addresses

1. General

2. Electronic Corrector Inspection Schedule
3. Device Programming Verification
4. Device Installation Verification
5. Corrector Edit Calculation
6. Documentation Activities
7. Records

METR 3.01	<p>New Meter Sizing</p> <p>1. B.: Revised to "Contact Gas Tech Engineering for selection and approval of meters larger than 7M175, delivery pressure greater than 10 psig or a connected load greater than 10,000 scfh."</p> <p>Removed Gas Engineering and Ameren Illinois Metering for those to contact.</p>	July 1, 2014	Janu- ary 1, 2016
METR 3.02	<p>Existing Meter Sizing</p> <p>1. B.: Revised to "Contact Gas Tech Engineering for selection and approval of meters larger than 7M175, delivery pressure greater than 10 psig or a connected load greater than 10,000 scfh."</p> <p>Removed Gas Engineering and Ameren Illinois Metering for those to contact.</p>	July 1, 2014	July 1, 2014
METR 3.03	<p>Regulator Sizing - 7" W.C. Delivery Pressure</p> <p>1. B.: Revised to "Contact Gas Tech Engineering for selection and approval of regulators with connected loads greater than 10,000 CFH and/or inlet pressures greater than 60 psig."</p> <p>Removed Gas Engineering for those to contact for selection and approval of a regulator.</p> <p>2. Approved Regulators:</p> <p>Replaced the American 1813C regulators with the Actaris B42R regulators as the preferred standard regulator. The American 1813C was moved to the METR 3.07 Alternate Approved.</p> <p>American has not been able to meet Ameren Illinois' supply needs so the Company is now ordering from Actaris.</p> <p>The 3/4" x 1" Actaris B42R with 1/4" orifice and 1-1/4" Fisher CS400IR with 1/4" orifice now require engineering review and approval before it can be ordered and installed.</p> <p>With a 1/4" orifice, the internal relief capacity is not adequate and a separate relief valve is required. To avoid the possibility of accidentally installing one of these regulators without a relief valve, Engineering has requested the use of these be reviewed and approved by Engineering. They are being re-</p>	Janu- ary 1, 2013	Janu- ary 1, 2016

moved from standard stock and placed in a Restricted category.

METR 3.04	<p>Regulator Sizing - 2 PSIG Delivery Pressure</p> <p>1. B.: Revised to "Contact Gas Tech Engineering for selection and approval of regulators with connected loads greater than 10,000 CFH and/or inlet pressures greater than 60 psig."</p> <p>Removed Gas Engineering for those to contact for selection and approval of a regulator.</p> <p>2. Approved Regulators:</p> <p>Replaced the American 1813C regulators with the Actaris B42R regulators as the preferred standard regulator. The American 1813C was moved to the METR 3.07 Alternate Approved.</p> <p>American has not been able to meet Ameren Illinois' supply needs so the Company is now ordering from Actaris.</p> <p>Added the Fisher 1-1/4" CS400IR with a 1/4" orifice</p> <p>Replaced the Fisher 2" CS823-IT with the CS826-IQ equipped with a 3/8" or 1/2" orifice</p> <p>Engineering evaluated the performance of both regulators and found the CS826-IQ performed better.</p>	July 1, 2014	January 1, 2016
METR 3.05	<p>Regulator Sizing - 5 PSIG Delivery Pressure</p> <p>1. B.: Revised to "Contact Gas Tech Engineering for selection and approval of regulators with connected loads greater than 10,000 CFH and/or inlet pressures greater than 60 psig."</p> <p>Removed Gas Engineering for those to contact for selection and approval of a regulator.</p>	April 1, 2013	January 1, 2016
METR 3.06	<p>Regulator Sizing - 10 PSIG Delivery Pressure</p> <p>1. B.: Revised to "Contact Gas Tech Engineering for selection and approval of regulators with connected loads greater than 10,000 CFH and/or inlet pressures greater than 60 psig."</p> <p>Removed Gas Engineering for those to contact for selection and approval of a regulator.</p>	April 1, 2013	January 1, 2016
METR 3.07	<p>Regulator Sizing - Alternate Approved</p> <p>1. C.: Revised to "Contact Gas Tech Engineering for selection and approval of regulators with connected loads greater than 10,000 CFH and/or inlet pressures greater than 60 psig."</p> <p>Removed Gas Engineering for those to contact for selection and approval of a regulator.</p> <p>2. 7 Inches W.C. Delivery Pressure</p>	January 1, 2013	January 1, 2016

The Actaris B42R was moved to METR 3.03. The American 1813C was moved to the Alternate Approved table.

3. 2 PSIG Delivery Pressure

The Actaris B42R was moved to METR 3.04. The American 1813C was moved to the Alternate Approved table.

4. 5 PSIG Delivery Pressure

The Fisher CS823-IT was removed from the table.

METR 4	Forms and Reference Materials	Janu- ary 1, 2014	Janu- ary 1, 2016
	Forms		
	Updated Form 03 - Gas Meter Data Sheet		
	Added Form 05 - Electronic Corrector Verification		
	Reference Materials		
	Added		
	Reference 10 - Grunsky Gas Meter Quick Change Equipment		
	Reference 11 - Actaris Itron B31 Series Regulator		
	Reference 12 - Actaris Itron B34 Series Regulator		
	Reference 13 - Actaris Itron B42 Series Regulator		
	Reference 14 - Actaris Itron CL34 Series Regulator		
	Reference 15 - Actaris Itron CL31 Series Commercial Regula- tor		
	Reference 16 - Fisher CS800 Series Bulletin		
	Reference 17 - Fisher 299H Bulletin		
	Reference 18 - Fisher CS400 Series Bulletin		
ODOR 0	Table of Contents	De- cem- ber 1, 2014	Janu- ary 1, 2016
	New:		
	ODOR 1 3. Odorization Sampling		
	ODOR 2.02 5. Liquid Odorant Tank to Tank Transfer		
	Revised:		
	ODOR 2.03 4. Employee Threshold Testing		
	ODOR 2.03 7. Records		
	Removed		
	ODOR 2.03 6. Guidelines for Odorant Test Locations		
	ODOR 4 Reference Material		
	Updates for		
	ZECK Z9000 User's Manual Rev 1		

ZECK Z9000 Installation and Maintenance Manual Rev 3

Added

Heath Odorator 2 User Manual Rev A

**ODOR
1**

Requirements

Janu-
ary 1,
2013

Janu-
ary 1,
2016

2. Odorization Requirements

2. A.: Removed "10,000 P.P.M." since our instruments read in percentage of gas in air.

2. B.: Revised the odorant usage rate to 0.50 to 4.0 pounds per million cubic feet of gas. Previous usage rate was 0.65 to 1.25.

2. D.: Grammatical change only Gas Technical Services replaced Gas Operations and Services.

2. E.: Revised to reflect that a supplement odorant injection rate may be lower than 0.50 lbs/MMCF at storage fields or other location where supply sources provide odorized gas. Previous had an injection rate of 0.65.

2. F.: Grammatical only by using the terms "odorizer type and injection rates" in lieu of "injection method and actual injection rates".

SMR Team comprised primarily of Gas Tech Services personnel suggested these changes based on what they are actually experiencing in the field.

3. Odorization Sampling - New Section

This new section describes the requirements for ensuring Ameren Illinois gas system is being properly odorized by performing periodic checks. Section identifies two methods; odorant intensity checks and sniff tests performed by qualified individuals as a means ensuring the gas is readily detectable. Section states that individuals performing intensity and sniff test be periodically examined to verify that they have a normal sense of smell.

SMR Team felt that ODOR 1 should state the requirements for periodic sampling.

**ODOR
2.02**

Odorization Operation

De-
cem-
ber 1,
2014

Janu-
ary 1,
2016

2. Odorization Location

2. B,: Revised to "Where individual customer(s) are served by an unodorized line supplemental odorizer equipment shall be installed."

Previously it stated odorizer equipment would be installed if customer was between delivery point and odorizer station. This may not always be true since there are some locations where the delivered gas is odorized.

2. C.: Revised for clarification to "Odorization equipment is located to ensure that all gas supplied by the Ameren Illinois' gas system is adequately odorized so that it is readily detectable by an individual with normal sense of smell."

The normal sense of smell language was added since that is the Code, Part 192.625, requirement for adequate odorization.

3. Odorization Equipment

Former 3. B.; Removed the listing of the types of odorizers currently being used at Ameren since this is always subject to change.

3. D. Grammatical addition only by replacing 'SCADA" with "remote monitoring".

Former 3. F.: Removed the issue of using sealing compounds on threaded joints. Team felt this is a training issue and does not need to be in the O&M.

Former 3. G.: Removed the issue about designing odorzier with adequate storage. Team didn't feel this needed to be in O&M.

All of the following revisions were made by the SMR Team comprised mainly of GTS personnel. Since GTS has the primary responsibility for odorization, the team felt these revisions more closely reflected the processes and procedures being utilized throughout Ameren Illinois.

4. Odorization Operation and Inspection

4. A.: Added "odorant consumption and odorant level" and an option for Gas Control to dispatch a GTS technician when an abnormal condition is detected. "Adequate odorization requires careful monitoring of the odorizers, odorization rates, odorant consumption, odorant levels, and odorant intensity. Where applicable, Gas Control will monitor odorizer operations that have remote monitoring capability and will contact the appropriate Gas Technical Services (GTS) Supervisor for consultation, instructions or dispatch a GTS technician to investigate when abnormal operating conditions are detected."

4. A. (1): Grammatical changes only: GTS for Gas technician and odorizer station for odorizer location.

4. A. (3): Added instructions for GTS Technicians:

(3) GTS Technician will document:

- (a) As found conditions
- (b) Immediate corrective actions
- (c) As left conditions
- (d) If follow-up action is required

4. B.: Added a sentence regarding more frequent inspection of odorizer. "Bypass, drip and positive injection odorizers shall be inspected at least monthly and entered within ClickMobile.

UNCONTROLLED IF PRINTED

More frequent inspection(s) may be necessary depending on the type of odorizer, means of monitoring odorant storage level, characteristics of gas demand and time of year i.e grain drying season."

4. C.: Expanded the farm tap odorizer inspection to:

C. Farm tap odorizers:

(1) Shall be checked annually for condition, operation, usage and refilled when required.

(2) Perform an annual sniff test to verify gas is odorized

4. D.: Grammatical, replaced odorant concentration level with odorant injection/usage rate.

4. D.: Added that farm taps are exempt from monthly checks.

4 D (1): Grammatical revision in the wording to "This check shall involve calculating the average odorant usage by measuring the volume of odorant consumed during a specified period of time, normally monthly, and dividing that number by the measured corrected volume of gas during the same period."

4. D. (2): Revised to be more specific on what information is maintained in Maximo monthly. "Monthly odorization usage, Lbs/MMCF, will be calculated and maintained in Maximo."

4. D. (3): Grammatical revision only by adding a few new words ; "The Monthly Odorization Report can be utilized as a worksheet to help manually calculate odorant usage, rate of odorization, and/or odorant reserve."

4. D. (4): Inserted new item; "Ameren's average target odorization introduction rate is one pound of odorant per million cubic feet of corrected gas volume (1 Lbs/MMCF). Monthly odorizer adjustments may be necessary to maintain the target rate."

4. D. (5): Updated the acceptable range of odorant usage rate to 0.50 to 4.0 lbs/MMCF and added information about warning message in Maximo. "If the calculated usage is less than 0.50 or greater than 4.0 Lbs/MMCF, a warning message will be displayed in ClickMobile. If the warning message is displayed, corrective action shall be taken to reestablish an odorization rate at target level and then notify GTS Supervisor."

4. D. (6): Inserted new item on what corrective action can be taken as a result of the warning message.

(6) Corrective action that may be considered but are not limited to:

(a) Increase, decrease, stop or valve-off odorizer

(b) Flaring

(c) Gas system purging

(d) Site mitigation

(e) Verification:

UNCONTROLLED IF PRINTED

- I. Odorant intensity tests with odorant intensity equipment
 - II. Perform increased odorizer operation inspections
 - III. Other actions as specified by GTS Management
4. E.: Revised to clarify who does the annual review and how the odorant introduction rate is determined.
- E. "GTS Supervisor shall conduct an annual review of the average odorant injection rates, by-pass rates, and actual quantities of odorant consumed at each odorizer installation. This review will ensure adequate odorization and provide documentation that each odorizer site is configured, adjusted, operating properly and has provided the prescribed odorant-to-gas ratio specific to that site. This check shall involve calculating the odorant introduction rate by measuring the volume of odorant consumed during a specified period of time and dividing that number by the measured corrected volume of gas delivered during the same period."
5. Liquid Odorant Tank to Tank Transfer
5. A. As Safety is the first priority, the following safe practices should be observed:
5. A. (1): Added "PHMSA" in the following; "Natural gas odorant, mercaptan, is a Class 3 flammable liquid designated hazardous by PHMSA and listed in the Hazardous Material Regulation Guide (HMRG)."
5. A. (3): Grammatical only by replacing "filled out" with "completed". "Ameren Shipping Paper for Odorant must be properly completed and remain within reach of the driver during transport. Gas Technical Service should be contacted for more information. Shipping papers are required whether the tanks are empty or full. See ODOR 4"
5. A. (4): Added "or greater" to the amount of odorant being transported that requires placards on the vehicle/trailer.
- (4) "Bulk loads of 1001 pounds or 119 gallons or greater must be placarded with the identification number of 3336 and a hazard class of 3 shall be displayed on all four (4) sides of the truck or trailer and be readily visible and not obscured."
5. A. (5): Added the word "bulk" to "Placards must remain on bulk odorant trailer even when empty."
5. A. (6): Revised to "Shipping papers are required with hazmat loads that exceed the Material of Trade Exception for a Class 3, Packing Group 1 material (one pound or one pint of odorant)."
5. A. (7): Clarification that HAZMAT endorsement is required when transporting more than 119 gallons or 1001 pounds.
- (7) "HAZMAT endorsement (x) is required on CDL to transport hazardous materials in bulk, 119 gallons or more, 1001 pounds or more and some non-bulk odorant shipments."

UNCONTROLLED IF PRINTED

- 5. A. (8): Inserted "it is recommended" to provide flexibility.
(8) "Use the weather to your advantage; it is recommended to avoid low atmospheric pressures and unfavorable winds when working with odorant."
- 5. A. (10): Removed the list of required PPE and replaced with; "Wear the proper PPE, as required, rubber gloves and eye protection."
- 5. A. (11): Added the word "solution"; "An eye wash solution should be available for immediate use."
- 5. B. The following procedures should be followed when transferring liquid odorant from the delivery vehicle to the target vessel:
 - 5. B. (1): Grammatical, substituted "qualified through appropriate training and experience" instead of "knowledgeable, trained, and qualified".
(1) "Individuals shall be qualified through appropriate training and experience in handling liquid odorant."
 - 5. B. (3): Grammatical, replaces "suitable" with "compatible".
(1) "Hoses should be compatible with liquid odorant and have the correct pressure rating."
 - 5. B. (4): Revised to:
(4) "Hoses and fittings should be checked for cracks and damage prior to beginning transfer. If damage is found, hoses and fittings should be properly disposed."
 - 5. B. (5): Delete reference to ACIG 1 since it was not relevant.
 - 5. B. (6): Simple word change "should" for "must".
(6) "Pressure should be ten (10) to twenty (20) psig greater in the delivery vessel than in the target vessel to create adequate differential to move odorant into the target vessel."
 - 5. B. (9): Revised to exempt filling of wick odorizer.
(9) "Open pouring or siphoning of liquid odorant should be avoided except when filling wick odorizer(s)."
 - 5. B. (11): Simple word change "Use" for "Allow".
(11) "Use blow-back connections to clear lines of suspended liquid odorant prior to disconnecting and depressurizing."
 - 5. B. (13): Added reference to ODOR 2.04 Deodorizing Agents
(13) "Clean all tools and fittings with deodorizing agent to mitigate odors in transit. See ODOR 2.04 Deodorizing Agents"
- 6. Odorant Leakage, Spillage, Disposal
 - 6. A.: Added a warning to not mix liquid bleach with commercial neutralizing agents.

UNCONTROLLED IF PRINTED

A. "Small odorant spills that may occur when repairing odorization equipment can be neutralized with liquid bleach or commercial agents. Do not mix liquid bleach and commercial neutralizing agents."

6. C.: Revised position titles:

C. "Large odorant spills shall be reported to GTS Supervisor and Division Gas Superintendent as soon as possible to coordinate the containment and remediation of the spill."

6. D.: Specified GTS Supervisor would make notification:

D. "GTS Supervisor should notify Gas Dispatch and Gas Control of the spill."

6. F.: GTS will coordinate disposal of odorant container not Ameren Environmental Services.

F. "GTS Supervisor should notify Gas Dispatch and Gas Control of the spill."

6. G.: Simple word change "remote monitoring" for "SCADA".

G. "Following clean-up or when the odorizer is placed back into normal operation, contact Gas Control to verify remote monitoring indicates normal operation and to check out."

7. Records

7. A.: Added "minimum":

A. "Monthly odorization rates shall be maintained in Maximo for a minimum period of 3 years. Paper documents can be used as supplemental information."

**ODOR
2.03**

Odorant Intensity Testing

2. Odorant Intensity Testing

2. A.: Added reference to ODOR 1 for normal sense of smell.

3. Intensity Test Instruments and Readings

3. B. (3): Added the Heath Odorator 2

3. I.: Added Gas Supervisor will notify Gas Tech Supervisor promptly.

I. "If a reading outside this range is found, it shall be immediately reported to the Gas Supervisor by the person conducting the odorant intensity test. The GTS Supervisor shall be notified whenever an intensity reading is outside of the 0.1% to 0.8% range. Corrective actions for unacceptable odorant intensity variances are required at that time. Corrective action(s) shall be documented within ClickMobile and Maximo."

GTS Supt requested that GTS Supv be notified whenever an intensity reading is outside of the 0.1% to 0.8% range.

3. K.: Revised the position on having customer perform the intensity test by replacing "it is recommended" with "may ask".

De-
cem-
ber 1,
2014

Janu-
ary 1,
2016

K. "When a customer is available during the odorant intensity test, the gas field personnel may ask the customer if they would like to perform a test and to document the results."

Having a customer perform the test should be strictly voluntary on the customer's part with no pressure exerted by the gas field personnel.

5. Selection of Odorant Intensity Test Sites

5. A.: Added GTS Supervisor, GTS Engineer, or Gas Engineer and removed Gas Supervisor as those who would establish a schedule and locations.

A. "The GTS Supervisor, GTS Engineer or Gas Engineer shall establish a schedule and the locations for conducting odorant intensity checks. Choosing the proper test point locations is critical to the success of the odorization process."

5. B.: Simple word change "delivery points" in place of "gate stations".

B. "The number of sites selected will depend on the size and configuration of the odorized system, location of the delivery points, and locations where odorant intensity is reported to be not readily detectable."

5. C: Added Gas Engineer in addition to the Gas Supervisor who shall establish a survey plan for conducting intensity tests.

C. "The Gas Supervisor or Gas Engineer shall establish a survey plan which lists the pre-determined locations for conducting odorant intensity tests."

5. D. Contains guidelines for selecting test sites. This was formerly section 6. Guidelines for Odorant Test Locations. Majority of the items previously under 6. are now in under 5. D.

5. D. (4): Added "At the end of recently installed long gas main extension."

This was added to check to make sure odorant is recognizable at the end of new section of pipe and that the new pipe has not absorbed the odorant.

5. G.: Inserted GTS Supervisor, GTS Engineer or Gas Engineer in place of Engineering on who should annually review sample sites.

G. "Sample sites should be reviewed annually GTS Supervisor, GTS Engineer or Gas Engineer and Operations as part of the annual System Review."

The SMR Team removed the following items from previous 5. Selection of Odorant Intensity Test Sites:

5. D. Choosing the proper test point locations is critical to the success of the odorization process.

5. E. The minimum number of survey points per odorized system is determined by the following table: The Table was re-

moved that listed the minimum number of required checks per month based on the number of meters per odorized system.

The SMR Team removed the following items from previous 6. Guidelines for Odorant Test Locations.

6. G. Areas with large quantities of new steel pipelines should be considered for test sites.

6. H. In small systems (typically small towns fed by individual pipeline taps), the practice of rotating the test location on a monthly basis may be utilized. This allows small systems to be evaluated for low flow and/or dilution/fade conditions that may not be apparent using other site location methods.

6. I. Areas of rapid system growth should be considered for test sites. In these areas large amounts of main are typically installed several years before any substantial load is present, creating a potential low flow/dead end system.

6. J. In addition to predetermined location readings, random test locations should be included to monitor for any aberrations that may be present.

7. Records

Added "Odorant Intensity Test" - "Odorant Intensity Test records shall be retained in Maximo for three (3) years"

ODOR 4	Forms and Reference Materials Reference materials updates for Reference 7 - ZECK Z9000 User's Manual Rev 1 Reference 8 - ZECK Z9000 Installation and Maintenance Manual Rev 3 Added Reference 10 - Heath Odorator 2 User Manual Rev A	De- cem- ber 1, 2014	Janu- ary 1, 2016
OQAL 0	Table of Contents Forms and Reference Materials Added Form 02 - OQ Task Disqualification Form	Janu- ary 1, 2012	Janu- ary 1, 2016
OQAL 1	Requirements 1 B.: Removed "ASME B31Q". Ameren Illinois' OQ plan meets the federal requirements of Part 192 and Illinois Admin Code 520. 1. C.: Added ""approved equivalent" to ASME B31Q as the standard by which gas personnel and other individuals are qualified. 2. Program Implementation "Gas Compliance and Training" replaced "Safety and Training"	Janu- ary 1, 2013	Janu- ary 1, 2016

3. Definitions

3. D.: Revised to "B31Q Covered Task Manual - Contains task specific information, AOC's and O&M procedure references associated with each covered task."

3. O.: Added "On the Job Training" to define what is meant by the term OJT.

3. S.: New inserted "Proctor - An individual selected to administer a written examination."

3. X.: "Subject Matter Resource" replaced "Subject Matter Expert"

4. Covered Tasks

4. A.: "Gas Compliance and Training" replaced "Safety and Training"

4. B. (4): Deleted this item, "Difficulty, Importance Analysis"

5. Abnormal Operating Conditions

"B31Q Covered Task Manual" replaced "B31Q Covered Task Procedure Manual"

6. Evaluation Guidelines

6. B. (1): "Gas Compliance and Training Department" replaced "Gas Training Department"

6. B. (2): Revised to "Any written or computer based exams taken under the observation of an evaluator or an approved exam proctor. A list of approved proctors will be kept on file by the Gas Compliance and Training Department."

6. F.: New inserted, "Communication of Disqualification - When an employee is disqualified for a covered task, the OQ Task Disqualification Form (See OQAL 4) will be completed and promptly communicated with Gas Operations."

6. G.: "Gas Compliance and Training" replaced "Safety and Training"

6. I. (3): "Gas Compliance and Training" replaced "Safety and Training"

6. J. (2): "Gas Compliance and Training" replaced "Safety and Training"

6. K. Re-Evaluation Intervals

6. K. (1): Revised to "Ameren Illinois will utilize the ASME B31Q Covered Task list, as referenced in Appendix 5A of the ASME B31Q standard, as the basis for establishing re-evaluation intervals. Covered Tasks specific to Ameren Illinois will be evaluated independently to determine the proper re-evaluation interval."

7. Non-Qualified Individuals

7. A. (3): "Covered Task List in section 16 of this document" replaced "Covered Task List in OQAL 1."

8. Mutual Assistance

8. C. (1): Revised to clarify, "List of qualified employees with covered tasks they are qualified to perform"

10 Management of Change

10. C.: Revised to "All Management of Change records shall be maintained by the Gas Training Center or electronically in the Insight Learning Management System."

10 E.: Revised to "The appropriate Regulatory Agencies (i.e. ICC Pipeline Safety) will be notified when significant OQ written program changes are made."

11. Documentation & Record Keeping

11. A.: "all employees" replaced "all new personnel and existing", "Ameren Illinois will ensure all employees' qualification records are maintained using electronic and/or hard copy."

11. C.: New, " Ameren Illinois will maintain a listing of all employees and contractors employed on its property."

12. Contractors

"Ameren Illinois Gas Compliance and Training" replaced "Ameren Illinois Safety and Training" throughout this section

12. D. Hiring Requirements for Contractors Qualified Under the Ameren OQ Plan

12. D. (6): Revised to " Once all the requirements have been satisfied, the hiring party will be notified and the completed Checklist will be maintained with the Contractor OQ records."

13.OQ Review Meeting

13. C. (4) (a): "Ameren Illinois Gas Compliance and Training" replaced "Ameren Illinois Safety and Training"

14, Training

14. B.: "Ameren Illinois Gas Compliance and Training" replaced "Ameren Illinois Safety and Training"

15. Refresher Training

15. A.: Revised to "In addition to OQ evaluations, individuals that perform covered tasks will receive refresher training. This refresher training will focus on core areas of a specific covered task or a group of related covered tasks. Topics may be chosen by applicability to work groups or based on field performance observations, with at least one refresher training topic covered each calendar year."

15. B.: New, "In addition, refresher training on Leak Management Procedures will be conducted on an annual basis."

16. Covered Task List

UNCONTROLLED IF PRINTED

- Task numbers 0671, 0741, 0771, 0791 have been removed as AIC does not use or have procedures for these joining methods.
- Task numbers 0831, 0841, 0851 as these are related to maintenance of Cast Iron systems
- Task numbers 1631 and 1641 Launching/Receiving Pigs are being added.
- Task 1651 - Purging is being added. This was previously covered under Task A002 - Purging/Abandonment
- Task A002 is renamed as Abandonment
- Tasks 1231, 1241, 1261, 1271, 1281, and A003 are revised from a 3 Year Re-evaluation interval to a 1 Year Re-evaluation interval per Leak Management Qualification agreement with the ICC.

OQAL 4	Forms and Reference Materials Added: Form 02 - OQ Task Disqualification Notice	January 1, 2012	January 1, 2016
PMRK 1	1. E.: Removed the December 31, 2015 date and replaced with Any markers or signs identified that do not have the Ameren Illinois logo and phone number and cannot be immediately corrected, will be documented in Click Mobile as 'Pipeline Marker / Signage Issue' and shall be replaced within 30 days." Revision was submitted by Gas Compliance to address how pipeline markers, without the correct label, found after December 31, 2015 are to be handled.	January 1, 2014	January 1, 2016
POLY 0	Table of Contents Revised POLY 1 4. Clearances from Thermal Sources Added POLY 2.02 3. Above Grade Squeeze Added POLY 2.05 6. Electrofusion Elbows Added POLY 3.02 7. TDW PE Side Tap Fittings Forms and Reference Materials Added: Reference 23 Innogaz Installation Procedures Reference 24 IPEX Friatec Installation Procedures Reference 25 Central EF Installation Procedure Manual	July 1, 2014	January 1, 2016
POLY 1	Requirements 2. Handling	July 1, 2014	January 1, 2016

UNCONTROLLED IF PRINTED

2. A.: Grammatical only "may be" replaced "are"; "Coils of PE pipe may be sequence banded to permit controlled uncoiling of the pipe."

2. B. Grammatical only "run" replaced "ran" and "the pipe is" replaced "it is"; "When installing 4 inch and larger coiled PE pipe, the pipe must be run through straightening and re-rounding equipment as the pipe is removed from the pipe trailer."

2. C.: Grammatical only, rearranged text, "The straightening and re-rounding equipment instructions do not recommend installing 4 inch and larger coiled pipe when the temperature is below 32°F for an extended period. Stick pipe, 4 inch and larger, should be considered when temperatures are below 32°F. See POLY 4"

2. D.: Revised: "The shelf life of PE2406/PE2708 and PE3408/PE4710 manufactured on March 6, 2015 and earlier shall not exceed two (2) years."

2. E. New: "The shelf life of PE2708 (MDPE) manufactured on March 7, 2015 and later shall not exceed three (3) years and PE4710 (HDPE) manufactured on March 7, 2015 and later shall not exceed ten (10) years from the manufactured date stamped on the pipe."

Revised to reflect the PHMSA's incorporation by reference the latest ASTM D2513 standard into PART 192.

2. F.: Grammatical only, added the word "stated", "PE pipe stock should be rotated to prevent the pipe from exceeding the above stated shelf life."

3. Support

3. A.: New item: "For permanent installation PE pipe must be installed below ground."

This revision allows for PE pipe to be temporarily installed above ground which is allowed in Part 192.321.

3. C: Word change, "steel" replaced "metal", "Protective sleeves must be installed on the outlet of all service tees and on all steel-to-plastic transition fittings to minimize shear stresses by distributing the earth loads across the rigid connection."

3. D.: New item, "Whenever PE pipe is exposed consideration should be given to providing support to minimize stresses due to excessive sagging."

Addresses the need to recognize that excessive sagging of PE pipe could adversely affect the integrity of the pipe joints.

4. Clearance from Thermal Sources - Changed the heading title and added more information.

"PE pipe shall be installed with sufficient clearance, or insulated, from any source of heat, such as steam pipes, to avoid temperatures in excess of 100° F, impairing the serviceability

of the pipe. Typically, twelve (12) inches is considered sufficient clearance."

Clarified the need for protection from thermal sources and a guide as to what is sufficient clearance.

5. Joining

5. A.: Grammatical change, "shall only" replaced "may be".

"PE pipe shall only be joined by butt fusion, electrofusion or mechanical fittings."

5. B.: Grammatical change only by deleting reference to POLY 2.03 Heat Fusion Joining since it does not actually provide procedures.

Former 5. B. "Threaded joints are prohibited" was removed since it is no longer relevant with the revision to 5. A.

6. Thermal Expansion and Contraction

6. A.: Added "MDPE and HDPE pipe have the same expansion and contraction coefficients."

Added to clarify that medium density and high density pipe will expand and contract the same.

6. A. (2): Added a second example for expansion of a service line,

"100 feet of 1/2 or 1 inch PE pipe heated to 100°F in the sun can contract 4 inches when buried in 60°F soil. Thus, slack in the service line should be left near the service tee."

7. Minimum Bending Radius

7. B. Expanded the explanation of the information provided in the Permanent Minimum Bend Radius table and updated the bend radius for PE pipe sections that contain a fitting. The pipe manufacturers reduced the bend radius from 125 times the pipe diameter to 100 times.

Added a clarification that butt fusion joints are not considered a fitting.

8. Weak Link

8. B. Removed "but not limited to"

8. B. (c): New: "A weak link may be created by physically removing approximately 50% of the pipe wall by drilling holes or cutting slots in the pipe. Scoring is not an acceptable method for reducing the wall thickness."

SMR Team added to reflect a procedure that is currently being used in some areas of the Company.

8. B. (d): New: "Install commercially available manufactured weak link designed for the pipe size being installed."

8. B. (e): Added "back reamer", "Bore head/back reamer that are one (1) inch or more, larger in diameter than pipe being in-

stalled can take the place of a pull plug when the PE pipe is being pulled in behind the boring rods."

8. B. (f): New: "A weak link is not required when the pipe is pulled by hand."

8. B. (2) (a): Revised to make it acceptable to use a MDPE weak link when pulling HDPE pipe.

9. Tracer Wire

9. A. Table: Added a note that "#14 solid soft drawn copper tracer wire, 18 66 677, is approved for only service line insertion if there is insufficient space for #12 tracer wire."

Many times a #12 wire is too large to insert into a 3/4" steel service when a 1/2 inch PE pipe is being inserted.

9. D.: Revised to; "Consideration should also be given to using stainless steel tracer wire for long and/or difficult directional bores or plow-ins. When stainless steel wire is installed with main, a test station should be brought up at the location where the stainless wire meets the copper wire. A lead from each wire should be run up and terminated in the test station. If installation of a test box is not possible or feasible, the stainless and copper tracer wires can be connected in the same manner as copper service line tracer wire is connected to stainless steel main line tracer wire."

The preference is still to install test station where the stainless steel wire and copper wire meet but this revision does allow for the two wires to be connected if needed.

9. E.: New "When connecting PE service line copper tracer wire to the PE main stainless steel tracer wire, the wires can be connected with a stock coded split bolt connector. The connection should be coated with TL101 Corrosion Inhibitor, 31 59 733, then encapsulate in gel box."

Connecting a copper tracerCorrosion Control requested the Corrosion Inhibitor be applied with joining the stainless and copper tracer wire.

9. J.: Revised to "Considerations should be given to installing test lead box(s) or pipeline marker(s) with fink station as tracer wire access points when service line connections are not available."

Revised to provide examples of methods that can be used to provide access to tracer wire on long runs of PE pipe when there are no services.

12 Buried Pipe Examination

12. A.: Added reference to ClickMobile.

**POLY
2.02**

Squeeze Off

1. B.: Removed the sentence "However, squeezing may not provide 100% shut-off in all cases."

April
1,
2012 Janu-
ary 1,
2016

1. C. New: "When squeezing a line that has two or more feeds into the area, a pressure gauge should be installed on the live side of the squeeze and monitored throughout the stopping operations. See PRES 2.03 Potential Over Pressurization or Service Interruption."

Emphasizes the importance monitoring pressures when squeezing off a PE pipe segment to isolate an area when there are multiple leads into the area.

2. Operation

2. I.: Removed the first sentence "If squeeze-off does not provide 100% shut-off, venting may be required."

SMR Team felt in - lieu of venting, it is best to stay with practice of installing a second squeezer.

3. Above Grade Squeeze - New section was added to address the use of above grade squeeze tools.

A. PE pipe can be squeezed, without requiring gas field personnel to enter the excavation, by the use of a long handle squeeze tool.

B. Since personnel are not entering the excavation to apply the squeezer, cleaning and eliminating static charge of the pipe are not required.

C. The squeeze off tool shall be grounded.

D. If the squeeze off is to be performed in a blowing gas atmosphere, gas field personnel should follow procedures in WWBG 2.01 Hazardous Atmosphere

SMR Team added since this was not included in our O&M procedures.

POLY 2.05

Electrofusion

1. General

1. D.: New: "Electrofusion processors shall be calibrated at intervals that at least meet the requirements contained in Manufacturer's Instructions. See POLY 4 There will be a compliance period of the manufacturer's recommended interval plus ninety (90) days. Beginning no later than January 2016, calibrations records will be maintained in Maximo."

ICC issued a NOA indicating procedures need to be added to the O&M as to when and how processors were to be calibrated. The calibration intervals varied from 1, 2 and 3 years depending on the processor. The manufacturer's instructions will indicate the interval.

1. H.: New: "Some fittings utilize resistor pin technology which allows the processor to automatically read the fusion time when it is attached to the fitting. The fittings that do not utilize resistor pin technology require the barcode to be scanned to complete the fusion."

January 1, 2014

January 1, 2016

Was added to address the different control boxes that are now being used in Ameren Illinois.

1. I thru 1. N.: These are general topics that were previous repeated in each section of the procedures. They include: Use of 96% isopropyl alcohol, non-petroleum based markers, rotating scrapers, hand scraping, and replacing scraper blades.

1. O.: New: "If a square cut cannot be achieved, ensure that the resulting gap when measured with a square placed on the pipe end so that the gap between the pipe and the square is at its maximum width is equal to or less than what is shown in table below. The gap between two pipe ends should not exceed two (2) times the maximum gap shown in the table."

A picture and a table were also added.

Information that came from Central Plastics which specifies the allowable tolerance. Ameren Illinois Training personnel created the picture and table.

2. Equipment, Weather and Cleanliness Guidelines

2. B. (1): Revised to "If needed, pigtail adapter should only be used to fuse all sizes of tapping tees and 2 inch and smaller fittings (i.e. couplings, elbows, reducers, end caps)."

Clarifies on which fittings a pigtail adapter can be used.

2. B. (2): The word "fitting" replaced "coupling". "When fusing 3 inch and larger fittings the 30 amp twist lock connection is required."

2. C.: New: "For fittings larger than two (2) inches, a 3500 Watt generator or larger, or an appropriate 120 volt wall outlet must be used to power the electrofusion processors."

2. D. New: "Inverters over 3000 watts may be used to power electrofusion processors for 2" and smaller fittings.

Note: The compatibility of a specific inverter should be verified prior to using that inverter for electrofusion.

Fitting manufacturer provided these requirements.

2. E.: Revised the extension cord limitations and provided a table list the maximum cord length and size for each processor based on manufacturers' recommendations.

Processor	Extension Cord Maximum Length & Size
Central Easy Fuse & MSA 340	25 ft. - #10/3 50 ft. - #8/3
IPEX Genesis	25 ft. - #12/3 50 ft. - #10/3 100 ft. - #8/3
Friamat	100 ft. - #10/3 200 ft. - #8/3
Kerotest Diane & Charlotte	100 ft. - #10/3 200 ft. - #8/3

Current O&M specifies a minimum of #12/3 which does not meet the requirements of most processors.

3. Electrofusion Couplings (moved Elbows to its own section)

Reference to elbows was removed from this section.

3. A. Preparation Prior to Scraping

3. A. (5): Added to check for out-of-roundness that "A bar style pipe clamp may be used to assist with re-rounding the pipe if necessary."

"Note: Insert stiffeners could also be used for re-rounding for 1-1/4" and 2" pipe."

Central Plastic's procedures stress the importance of checking for out-of-roundness so it is being added to each procedure.

3. A. (6): Added a picture of a Central coupling showing the sprue that is used as a guide for marking the pipe end.

3. B. Scraping (Added this heading)

3. B. Removed the requirement to wipe the scraped area with 96% alcohol solution after scraping.

Central Plastic's procedures require cleaning the scraped area with alcohol solution only if it becomes contaminated from being handled, falling dirt or any other contaminant. This requirement is in our current O&M and is restated in 3. B. (2) of this update.

3. C. Joint Assembly

3. C. (1): Revised to "After scraping, if the insertion depth mark has been removed, remark insertion depth using an un-packaged coupling."

If the insertion depth marks are still visible, there is no reason to remark.

4. Electrofusion Service or High Volume Tees

4. A. (3): New: "Visually check pipe for out of-round condition. If the fusion area is found to be out-of-round, take appropriate steps to re-round the pipe by using an alignment or re-rounding clamp. A bar style pipe clamp may be used to assist with rerounding the pipe if necessary."

Central Plastic's procedures stress checking for and correcting out-of-roundness of the pipe, so it has been added to each fitting procedure.

4. A. (4): Revised marking the area to be scraped by replacing the instructions to mark the pipe a minimum of 1/2 inch wider than the tee on both ends with "mark the pipe on both sides of the tee slightly wider than the base so that the scraped area will be visible after the tee is fused to the pipe."

Central Plastic's procedure language.

4. A.: Removed the requirement to wipe the scraped area with 96% alcohol solution after scraping.

Central Plastic's procedures require cleaning the scraped area with alcohol solution only if it becomes contaminated from being handled, falling dirt or any other contaminant. This requirement is in our current O&M and is restated in 4. A. (6) of this update.

5. Electrofusion Caps

5. A. Preparation Prior to Scraping

5. A. (5): Added to check for out-of-roundness that "A bar style pipe clamp may be used to assist with re-rounding the pipe if necessary."

"Note: Insert stiffeners could also be used for re-rounding for 1-1/4" and 2" pipe."

Central Plastic's procedures stress checking for and correcting out-of-roundness of the pipe, so it has been added to each fitting procedure.

5. B. Scraping

5. B: Removed the requirement to wipe the scraped area with 96% alcohol solution after scraping.

Central Plastic's procedures require cleaning the scraped area with alcohol solution only if it becomes contaminated from being handled, falling dirt or any other contaminant. This requirement is in our current O&M and is restated in 5. B. (2) of this update.

5. C. Joint Assembly

5. C. (1): Revised to "After scraping, if the insertion depth mark has been removed, remark insertion depth using an unpackaged cap."

If the insertion depth marks are still visible, there is no reason to remark.

5. C. (1) (b): New "The spigot or end cap inserted into the coupling does not require scraping or cleaning and should not be removed during the process."

5. C. (2) thru (4): New

(2) Make sure that the spigot is inserted to the center of the coupling (1 below).

(3) If the spigot end cannot be restrained by the clamp, mark the spigot on the outside of the fitting so that movement can be detected during the fusion (2 below)

(4) Place the coupling or fitting kit over the scraped area, being careful not to contaminate the scraped pipe or fitting surface. Secure the fitting in place using the appropriate clamp. Standard electrofusion clamps can be used for fittings, even if the clamp does not actually clamp on the fitting surface. The

clamps should butt against the fitting end to prevent it from moving outward during the fusion process. Examples shown below:

Information came from Central Plastic's procedures

6. Electrofusion Elbows - New section that was separated from electrofusion coupling procedure.

6. A. (5): For re-rounding the pipe added A bar style pipe clamp may be used to assist with re-rounding the pipe, if necessary.

Note: Insert stiffeners could also be used for re-rounding 1-1/4" and 2" pipe.

6. A. (6): New, "Identify and mark area of the pipe to be scraped. Central Plastic electrofusion elbow has no markings on the outside of the fitting indicating the stab depth. Measurement should be taken for proper marking and scraping. For two (2) inch PE electrofusion elbow, mark pipe 2-1/4 inches from pipe end. This will indicate scraping area.

Note: If an Innogaz elbow is being used, there is a knit line on the outside of the elbow which indicates the insertion depth."

6. B. Scraping

Scraping procedures are the same as for the electrofusion coupling.

6. B. (2): As in the other procedures, the scraped area of the pipe and the inside of the elbow only require wiping with an alcohol solution if their surfaces have become contaminated after scraping.

6. C. Joint Assembly

6. C. (1): Revised to "After scraping, if the insertion depth mark has been removed, remark insertion depth. Electrofusion elbow has no markings on the outside of the fitting indicating the insertion depth. Measurements should be taken for proper insertion depth marking. For 2" PE elbow electrofusion, mark pipe 2 1/4" from pipe end This will indicate insertion depth of the pipe

Note: If an Innogaz elbow is being used, there is a knit line on the outside of the elbow which indicates the insertion depth."

6. C. (2) "Slide the elbow onto the first pipe, or tee outlet. The insertion depth mark should be visible on the pipe at the end of the elbow."

6. C. (3) "Insert the second pipe end into the elbow. The insertion depth mark should be visible on the pipe at the end of the elbow."

6. C. (4) "Improper positioning of the elbow may result in a failed joint."

6. C. (5) "Select the proper sized alignment clamp and secure pipe ends or tee outlet in the clamp with the elbow at or near the center of the clamp."

The above procedures are essentially the same as for couplings.

7. Cooling Times

7. A. Provided the cooling times for all of the Central fittings currently being stocked.

POLY 2.07	<p>Evaluating PE Pipe Damage</p> <p>1. B.: Correcting the definition of a defect to greater than 10% of the PE pipe wall thickness. Previous language had equal to or greater.</p>	January 1, 2011	January 1, 2016
POLY 2.09	<p>Plastic Fusion Qualification</p> <p>2. Fusion Qualification</p> <p>2. C. (2): Typo correction, "Butt" from "Buff"</p> <p>4. Requalification - Revised this section as follows:</p> <p>A. All Gas Field Personnel performing plastic fusion at Ameren Illinois shall be requalified on each fusion method once per calendar year not to exceed 15 months.</p> <p>B. Any Gas Field Personnel who makes a production plastic pipe joint that is found to be unacceptable during pressure testing shall immediately report the failure to the Gas Supervisor, and shall not perform any additional plastic pipe joining until requalified in the failed process. The Gas Supervisor shall notify Gas Compliance and Training to coordinate any remedial training needed, and requalification.</p> <p>There was a revision to Part 192.285, which became effective on October 1, 2015, requiring an individual to be requalified after that individual makes a fusion joint that fails during testing. This applies to both butt and electrofusion processes.</p>	July 1, 2014	January 1, 2016
POLY 3.01	<p>Butt Fusion Fittings</p> <p>2. Elbows: Corrected stock code for 8" PE 2406 elbow</p>	January 1, 2011	January 1, 2016
POLY 3.02	<p>Electrofusion Fittings</p> <p>Added:</p> <p>7. TDW PE Side Tap Fittings: 8" x 4"; 6" x 4"; 4" x 4"</p>	January 1, 2014	January 1, 2016
POLY 3.04	<p>Protective Sleeve</p> <p>Corrected stock code for 2.875" Inside Diameter Sleeve</p>	January 1, 2011	January 1, 2016

POLY 4	<p>Forms and Reference Materials</p> <p>Reference Materials</p> <p>Added:</p> <p>Reference 23 - Innogaz Installation Procedures</p> <p>Reference 24 - IPEX Friatec Installation Procedures</p> <p>Reference 25 - Central EF Installation Procedure Manual</p>	July 1, 2014	Janu- ary 1, 2016
PRES 2.04	<p>Overpressure Reporting</p> <p>1. B: Added contact Integrity Management group if transmission system is overpressurized.</p> <p>B. "The Gas Supervisor will immediately contact Gas Compliance personnel. If a transmission system was overpressurized, the Integrity Management group should also be contacted. See Forward"</p> <p>1. D.: Corrected position title to Manager, Gas Compliance and Training.</p> <p>D. "The Gas Supervisor should also report the following information in writing to Manager - Gas Compliance and Training within three (3) working days::</p> <p>1. E.: New item; "When overpressurization occurs within a transmission system, Gas Supervisor will provide Integrity Management group in Decatur with a copy of the above written report."</p>	Janu- ary 1, 2014	Janu- ary 1, 2016
PTRL 0	<p>Table of Contents</p> <p>PTRL 2.02 4. Patrol Requirements was removed in the July 1, 2014 Update</p>	March 1, 2010	Janu- ary 1, 2016
PTRL 2.01	<p>Transmission Patrols</p> <p>2. Transmission Main Patrol</p> <p>2. A.: Correction made "HCA's " replaces "HCS's"</p>	De- cem- ber 1, 2014	Janu- ary 1, 2016
PTRL 2.02	<p>Critical Area Patrols</p> <p>Critical area patrols will now include transmission pipelines as well as the high pressure distribution and distribution lines. Throughout the entire document "transmission" has been added. In addition, the word "pipeline" has replaced "main" throughout the document.</p> <p>Pipeline Integrity group feels utilizing the Critical Area Patrols process is more efficient and effective in monitoring exposed sections of transmission pipelines than attempting to do it through the mapping system.</p> <p>1. B.: Grammatical revision only, "When performing the patrol by foot, vehicle or by air, evaluate conditions which required</p>	De- cem- ber 1, 2014	Janu- ary 1, 2016

classifying the patrol as critical to verify the condition or serviceability of the pipeline have not worsened."

4. Processing Data

4. C.: New: "Notify Gas Operations and Services - Pipeline Integrity Group and Gas Tech Engineering when Critical Area Patrol(s) are needed for a transmission and high pressure distribution lines."

4. D. New: "Contact Gas Compliance for assistance in creating a Critical Area Patrol when conditions listed above are discovered and are not covered by an existing Critical Area Patrol."

Pipeline Integrity and Gas Tech Engineering will be the groups responsible for setting up the critical areas and making the evaluations of the condition of the gas line.

5. Records

5. C.: New: "For transmission lines, the patrol records shall be maintained for the life of the facility."

PTST 0	<p>Table of Contents</p> <p>PTST 1 Requirements</p> <p>Inserted 4. Design MAOP</p> <p>Revised 8. A Component Other Than Pipe Being Replaced or Added to Pipeline</p> <p>Forms and Reference Materials</p> <p>Updated</p> <p>Form 01 - Gas Leak & Strength Test Stamp</p>	<p>July 1, 2014</p>	<p>January 1, 2016</p>
PTST 1	<p>Requirements</p> <p>This document has been significantly revised and should be reviewed in its entirety. The revisions are too numerous to identify each. The major revisions within the document are:</p> <p>1. Short section of pipe has been defined as typically a double random length or approximately 40 to 45 feet or shorter. Another requirement that was added is testing a segment of pipe to establish its MAOP must be done after the is in its final location.</p> <p>2. Test recording methods was revised to list the type of gauges that can be used to record pressure tests and the table listing stock coded Process Gauges was updated. In addition, recording devices was expanded to include mechanical chart recorders, electronic pressure recorders, and calibrated dead-weight tester systems. A major change here is recording devices are only required when testing pipe that is being stressed to 30% SMYS or more. Gauges can be used for all other testing.</p>	<p>April 1, 2013</p>	<p>January 1, 2016</p>

3. Testing section was completely revised with tables replacing testing requirement verbiage. The tables are divided into the following categories:

- a. Service Lines - Less Than 2" Diameter; Plastic or Steel
- b. Plastic Main & Service with Design MAOP ≤ 100 PSIG
- c. Steel Main & Service with Design MAOP < 100 PSIG
- d. Steel Main & Service with Design MAOP ≥ 100 PSIG
- e. Fabricated Unit or Short Section of Pipe
- f. Farm Tap - Single Cut - 60 to 450 PSIG Inlet Pressure
- g. Farm Tap - Double Cut - 451 to 1000 PSIG Inlet Pressure

These tables provide the minimum required test pressure and duration. The tables also indicate when combination leak & strength test are acceptable or if separate leak and strength tests are required.

8. A Component Other Than Pipe Being Replaced or Added to Pipeline was expanded as a result of a recent PHMSA rule-making change. A component which carries a pressure rating only needs to be leak tested for approximately 10 minutes. However, once another item, pipe, fitting, or another component is attached to the component it becomes an assembly and must be tested accordingly.

SMR Teams have worked on pressure testing requirements for over year attempting to make them clearer and simpler. The concept of using a table format similar to a flowchart hopefully makes it easier to ensure the correct pressure tests are being performed.

**PTST
2.01**

Leak Test

This document has also been significantly revised to be compatible with PTST 1 and should be reviewed in its entirety. The major revisions are:

- 1. Mains and services line(s) should be tested separately.
- 3. The leak test duration section was revised to reflect a major change in determining the required leak test duration for PE pipe with MAOP of 100 psig or less and for steel pipe with MAOP less than 100 psig. The use of the original formula of 5 minutes per inch diameter per 100 feet can still be used until the calculated required duration exceeds 8 hours. Eight hours is the maximum required leak test duration regardless of the footage to be tested. The leak test can be left on for longer than 8 hours and the actual time recorded. For steel pipe with MAOP 100 psig or greater, the required leak test duration is a minimum of 1 hour as shown in the table in PTST 1. The previous 20 hour maximum leak test duration has been eliminated.
- 5. The leak test records section was expanded to include the electronic recorders and deadweight testers. A statement was

January 1,
2014

January 1,
2016

added that leak tests performed on service lines are recorded within ClickMobile. PTST 2.01 applies to leak testing of mains.

PTST 2.02	<p>Strength Test</p> <p>This document has also been significantly revised to be compatible with PTST 1 and should be reviewed in its entirety. The major revisions are:</p> <ol style="list-style-type: none"> 1. Strength test duration are shown in the tables in PTST 1. 3. The strength test procedures section now includes the electronic recorders and deadweight testers. It also allows for the test pressures to be left on the pipe until the final tie in is made. 4. The strength test records section now includes the electronic recorders and deadweight testers. The recording devices are now required only for recording the tests on mains or services with design MAOP of 30% SMYS or greater. Gauges can be used to record strength test on all other mains or services. 	<p>April 1, 2013</p>	<p>Janu- ary 1, 2016</p>
PTST 4	<p>Forms and Reference Materials Updated</p> <p>Form 01 - Gas Leak & Strength Test Stamp - Tie-in Joints Leak Test line was added.</p>	<p>July 1, 2014</p>	<p>Janu- ary 1, 2016</p>
PUBL 0	<p>Table of Contents</p> <p>PUBL 2.02 Liaison with Fire, Police and Public Officials, added Fire and Police</p> <p>PUBL 2.02 3. Mailings, removed Annual</p> <p>PUBL 4 Forms and Reference Materials</p> <p>Added Reference 02 - 2014 Brochure for Public Officials</p> <p>Added Reference 03 - Natural Gas Safety Flyer</p>	<p>Janu- ary 1, 2011</p>	<p>Janu- ary 1, 2016</p>
PUBL 2.01	<p>Public Notifications</p> <ol style="list-style-type: none"> 2. Gas Safety Notification to New Customers <ol style="list-style-type: none"> 2. A.: Grammatical only "flyer" replaced "pamphlet", Natural Gas Safety flyer, Stock Code 37 22 287. 3. Gas Safety Notification to the General Public <ol style="list-style-type: none"> 3. E.: Grammatical added "Public Relations Department" to Ameren Illinois Communications. 4. C. (4): Remove "Tips for First Responders", this document has been eliminated. It was replaced by Natural Gas and Electrical Safety Emergency Responder brochure. 6. Records 	<p>Janu- ary 1, 2014</p>	<p>Janu- ary 1, 2016</p>

In this section, "files are maintained in the Gas Compliance Office " has been removed and replaced with "files are maintained on Public Awareness SharePoint site".

6. A.: Revised to "Ameren Illinois Public Awareness personnel will maintain a copy of the annual mailing and list of emergency responder training for fire, police, and other emergency agencies which include: dates, locations, topics, and number of attendees. This information is filed on Public Awareness SharePoint site."

Former 6. F. was removed, Public Awareness group does not maintain a copy of one call program's notification program.

PUBL 2.02	<p>Liaison with Fire, Police and Public Officials</p> <p>Throughout this document "fire, police" have been added where it previously only had "public officials".</p> <p>3. Mailings</p> <p>3. B.: New, "The sample Operator page and brochure for the public official mailing every three (3) years is provided in this section of the O&M Plan. The brochure, PIPELINE SAFETY, is in PUBL 4 Reference Materials"</p> <p>3. C: Added Operator Page, "This letter, natural gas emergency procedures and/or Operator Page along with a brochure should be mailed to fire, police, and public officials in the communities that Ameren Illinois provides natural gas service."</p> <p>5. Natural Gas Emergency Procedure</p> <p>5. B. (6): Added "free of charge", "Ameren Illinois responds to all calls regarding gas odors and other natural gas related problems free of charge on a 24-hour, seven day a week basis."</p> <p>6. Sample Letter of Emergency Procedure</p> <p>Updated the sample letter with an October, 2015 version</p> <p>7. Sample of Operator Page - New</p>	<p>Janu- ary 1, 2014</p>	<p>Janu- ary 1, 2016</p>
PUBL 4	<p>Forms and Reference Materials</p> <p>Updated Ameren Public Awareness Program</p> <p>Added Reference 02 - 2014 Brochure for Public Officials</p> <p>Added Reference 03 - Natural Gas Safety Flyer, Stock Code 37 22 287</p>	<p>Janu- ary 1, 2011</p>	<p>Janu- ary 1, 2016</p>
PURG 0	<p>Table of Contents</p> <p>PURG 2.01</p> <p>Revised 6. Using an Inert Gas Slug when Purging</p>	<p>Janu- ary 1, 2011</p>	<p>Janu- ary 1, 2016</p>

**PURG
2.01**

Purging Methods

July 1, 2012 January 1, 2016

1. A.: Revised to "This section outlines the procedures to be followed when purging gas mains and pipelines. Service lines two (2) inch and larger and five hundred (500) feet or longer are to be purged in the same manner as mains.

1. B.: Revised to "Gas Engineering or Gas Tech Engineering (GTE) will provide detailed purging plans prior to blow-down or purging operations on transmission mains, high pressure distribution mains, or service lines two (2) inches and larger and operating at more than 60 psig."

Revised the language to clarify which gas mains and services are to be purged in accordance with these procedures.

2. Pre-Purge Activities

2. B.: Added a sentence addressing liquids and debris, "When purging, the blow off area should be kept clear to avoid property damage or injury to gas field personnel and the public. There may be a potential for liquids or debris being ejected into the blow-off gas stream and landing downwind of the blow-off. Be aware of wind direction / speed and the presence of any potential sources of ignition with special emphasis on overhead power lines."

2. D.: Revised to "When a purge pipe is used, it must be a metallic pipe of sufficient length that vented gas does not create a hazard to the public, gas field personnel, or adjacent property. The purge pipe shall be grounded to eliminate static charge. In lieu of a purge pipe, service lines smaller than two inch can be purged through the service riser."

2. E.: New, "To purge a service line smaller than two (2) inch slowly open the meter valve to allow the air to be purged. Once gas is detected close the meter valve. Service lines two (2) inch and larger will be purged the same as a main."

SMR Team wanted to caution workers that there is a potential for liquids or debris being released during a purging operations. Team decided that since situations and conditions vary it was not necessary to specify a minimum length for the purge pipe. The length will be determined by the actual conditions. They also wanted to make it clear purging out a service line does not require a separate purge pipe. Item 2. E. was added as a reminder when purging a service line, especially one with an EFV, the valve should be opened slowly so as not to trip the EFV.

3. Purging Transmission, High Pressure Distribution Pipelines

3. A.: Revised to "When transmission or high pressure distribution pipelines are taken out of service or reduced in pressure either permanently or temporarily, the effort shall be coordinated with Gas Control. See ABND 1"

Gas Control needs to be notified when either a line is being totally shut-down or when the pressure in the line is being significantly changed. The alarm settings may need to be adjusted or Gas Control needs to know why the alarm is activated.

3. B.: Grammatical only, added "When practical", "When practical, the release of large volumes of gas into the atmosphere should be minimized by transferring as much gas as possible from the pipeline to be purged to other parts of the system."

3. C.: Added use of masking agent, "When purging or blowing down a transmission or high pressure distribution line in a populated area, considerations should be given to the noise level and potential gas leak calls. The use of a masking agent may be a solution to avoid gas odor complaints."

SMR Team felt that adding a masking agent may be an option for minimizing the odor complaints.

3. D.: Grammatical only added one word "when", " Blow-down valves should be turned to fully open position as quick as possible to minimize possible erosive damage to the valve which could occur when attempting to pass a high volume of gas through a partially opened valve."

3. E.: Revised to "If flaring is utilized, GTE will include procedures in the purging plan. See PURG 2.02 Venting Gas.

4. Purging of Air with Gas

4. A.: Added reference to min. inlet pressure tables, "When a pipeline is being purged of air with gas, the gas must be released into one end of the line in a moderately rapid and continuous flow. See Tables 1 & 2 that provides the minimum inlet pressure of the gas that will ensure adequate flow."

5. Purging of Gas with Air

5. A.: Added pipeline should not be pressurized above current operating pressure, "When a pipeline is being purged of gas with air, the air must be released into one end of the line in a moderately rapid and continuous flow. The pipeline should not be pressurized above the current operating pressure of the pipeline."

5. C.: Added a caution about liquids or solids that remain in pipeline could be combustible, "When purging from gas to air, purge to 0% Gas, keep in mind that purging removes only gaseous material. Liquids and solids found in operating pipelines are typically combustible and may remain in the line after purging. Spontaneous ignition can occur if adequate air supply is available to items such as filter elements."

Safety item added to remind workers of the potential for ignition due to products that could remain in the pipeline after the gas is purged.

6. Using an Inert Gas Slug when Purging

UNCONTROLLED IF PRINTED

6. A.: Revised to "When purging mains 8" and larger, gas field personnel should separate air/gas interface with an injected slug of inert gas. To inject the inert gas hose should be connected to a fitting."

6. B.: Added reference to Volume of Inert Gas table, "The slug of inert gas must be long enough to prevent the air/gas from mixing during the purge. See VOLUME OF INERT GAS (cu ft) table below."

6. D. (2): Clarification added if there is over a 3 minute delay in purging, "In no case should the delay between the injection of inert gas and air/gas be greater than three (3) minutes. A new slug of inert gas should be injected if there is a delay."

6. F. Table: Added table heading "Volume of Inert Gas (cu ft)"

7. Required Minimum Inlet Pressures

7. A.: Revised to "Tables 1 and 2 provide minimum inlet pressure required to maintain minimum flow during purging operations. The maximum inlet pressure should not exceed the current operating pressure of the pipeline."

8. Vacuum Purge/Air Mover

This section has been completed revised and expanded significantly with input from GTE personnel.

A. An alternative method to purging gas from a pipeline is to use a vacuum purge to extract the gas from the system displacing the gas with fresh air.

B. The vacuum/air mover is normally connected to one or more locations of the system extracting by vacuum the gas out of the system while opening the other points of the system to the atmosphere allowing air to be introduced.

C. Air movers displace the gas with large volumes of fresh air when connected to one point of the system and another point opened to the atmosphere.

D. When an air mover(s) is to be utilized to purge the pipeline, Gas Tech Engineering, GTE, is to provide a purging plan. GTE will use AGA's Purging Principles and Practice as a general basis for the plan.

E. It is critical that a good seal is made between the air mover and purge stack for the air mover to work properly.

F. A ground clamp or wire from the air mover to ground is required to dissipate static electricity buildup.

G. The type of valve the air mover is mounted on can reduce the air flow by limiting effectiveness of the air mover (ex. plug valve has a 40% reduction in flow). GTE will factor this into the purge plan.

H. Typically, before an air mover/vacuum purge operation, a slug of inert gas is injected through a closed loop to separate air from gas. See VOLUME OF INERT GAS table above.

I. Once the air mover is started, ensure fresh air is being drawn into the main (i.e. verify vacuum is established at location where air is to be introduced).

J. Once a CGI indicates 0% gas is in the pipeline at the site of the first "cold" cut, the cutting operation(s) can begin (i.e wheel cutter, guillotine, etc). After the initial cut and air is being introduced via a vacuum, a torch can be used for remaining cutting operations.

K. Prior to cutting with a torch or using a grinder, reduce the air mover rate to minimize spark travel.

10. Monitoring Purge

10. A.: New, "Install gauges of the appropriate range at the inlet and outlet of the purge to continuously monitor the pressure to assure adequate flow."

10. B.: New, "Continuously monitor inlet valves and maintain constant communication, radio or telephone, with other areas of the purge operations to control and limit purge velocity."

10. D.: Revised to "Purge pipeline completely from one end to the other, especially when purging air with gas."

10. E.: Added "at defined points", "Monitor pressures at defined points using gauges during the purging to ensure the correct pressures are maintained."

10. F. Revised to "Test the gauges to ensure they are functioning properly prior to purging."

QUAL 0	Table of Contents Revised 1. 3. Action Matter Bulletin	Janu- ary 1, 2013	Janu- ary 1, 2016
QUAL 1	Requirements Gas Training, Compliance, and Quality Assurance personnel have completely rewritten the Requirements document to better reflect the current Quality Assurance program.	Janu- ary 1, 2011	Janu- ary 1, 2016
QUAL 4	Forms and Reference Materials Updated all of QA Forms and added Form 19 Excavation and Job Site Protection	Janu- ary 1, 2013	Janu- ary 1, 2016
REGS 1	Requirements 1. Objective 1. B.: New item added;" New regulator stations installed to control the flow and regulate the pressure in a downstream main segment shall comply with these requirements. This was added to clarify that new regulator stations must comply with REGS 1 in effective at the time the station is installed. These requirements are not retroactive.	De- cem- ber 1, 2014	Janu- ary 1, 2016

REPR 1	<p>Requirements</p> <p>3. Approved Repair Methods</p> <p>3. A. High Pressure Distribution and Transmission Line Repairs</p> <p>In the table under Internal Defects, added "laminations, cracks" as other example.</p> <p>4. Steel Pipe Repair Methods</p> <p>4. H. Welded Full Encirclement Split Sleeve (Dresser Style 110 of 220 Reinforcing Split Sleeve)</p> <p>4. H. (2): New: "Full encirclement split sleeves are suitable reinforcing the pipe where internal defects such as laminations or internal corrosion as long as the split sleeve will extend beyond the internal defect and sound metal is far enough away from the defect so that the localized heating will not have an adverse effect on the defect."</p> <p>Clarifies that this fitting is an acceptable repair method for internal defects.</p> <p>4. J. Composite Wrap System</p> <p>4. J. (2): Added internal defects, "These systems are a rehabilitation option for steel gas pipes with external corrosion, gouges, grooves, dents and internal defects such as laminations and corrosion."</p> <p>4. L. Encapsulation</p> <p>4. L. (2) (a): Revised to, "The steel pipe will be pretested at a pressure which qualifies the MAOP to be the same as the pipeline on which it is being attached prior to installation. See PTST 1"</p> <p>Clarifies that pipe with the weld cap is to be pretested prior to installation.</p>	<p>De- cem- ber 1, 2014</p>	<p>Janu- ary 1, 2016</p>
RNST 1	<p>Requirement</p> <p>1. B.: Revised to, "Whenever reinstating a temporarily deactivated main, only the new pipe installed within the segment of main has to be tested in accordance with PTST1 before the main can be put back in service. See RNST 2.01 for more details.</p> <p>Revised to address mains where the supply of gas is only temporarily interrupted.</p> <p>1. C.: New, "When repairing a damaged section main, if a new section of pipe is installed, the new section of pipe has to be tested in the same manner as a new main. New section of pipe can be either pretested or tested prior to installation. See REPR 1 9. Testing of Repairs"</p>	<p>June 1, 2010</p>	<p>Janu- ary 1, 2016</p>

Added to address testing requirements for pipe being installed to repair a damaged line.

1. D.: New, "As a general rule, previously abandoned gas facilities that were physically disconnected from a source of gas, purged, sealed, and no longer being maintained should not be considered for reinstatement. However, if there is consideration to reinstate, the facility shall be thoroughly evaluated for its integrity and tested the same as a new facility installed at that location."

Added as a general rule and to provide a cautionary reminder of the need to perform an in-depth evaluation of the pipe's integrity.

**RNST
2.01**

Reinstating Mains and Services

3. Reconnection of Temporarily Disconnected Farm Tap Services

3. B. (1): Grammatical by "minimum" so that the test pressure of the service line is a minimum of 90 psig.

3. B. (2): Grammatical by "minimum" so that the test pressure of the service line is a minimum of 90 psig.

4. Reconnection of Temporarily Disconnected Mains

4. D.: Facilities Cut Into Sections:

Revised to "Facilities Cut Into Sections: New segments of main installed between the undisturbed sections of main shall be tested in the same manner as a new main in that location. See PTST 1."

5. Reinstating Service in Abandoned Lines

5. A. (1): New, "An in-depth evaluation must be performed to determine if the integrity of facility is or can be made suitable for reinstatement. The evaluation should be performed by personnel from various groups such as; Gas Tech Engineering, Division Engineering, Gas Tech Services, Corrosion Control, etc."

5. A. (2): Revised to "The abandoned facility shall meet all of the requirements of a new facility being installed at that location."

5. B. Inserting new PE service pipe inside abandoned steel service line...

5. B. (1): Added reference to SERV 2.08 Tracer Wire Installation

De-
cem-
ber 1,
2014

Janu-
ary 1,
2016

**SECR
0**

Table of Contents

Revised SECR 1:

1. Objective

Janu-
ary 1,
2013

Janu-
ary 1,
2016

2. Employee, Contractor and Service Vendor/Provider Responsibility

3. Direct Threats

Removed SECR 2.01 Communicating Security Threats

Removed SECR 2.02 Critical Gas Facility Security Measures

SECR 1	Requirements Totally revised this document and the entire Security Plan section of the O&M. Ameren Corporate Security now has an Ameren Gas Facilities Corporate Security Plan applicable to both Illinois and Missouri. The plan follows the Pipeline Security Guidelines as provided by Transportation Security Administration and Homeland Security. Corporate Security takes the lead in ensuring the proper risk control measures are taken Ameren Illinois' Critical Gas Facilities. They will work directly with the management personnel responsible for those facilities.	Janu- ary 1, 2013	Janu- ary 1, 2016
-------------------	---	-------------------------	-------------------------

SECR 2.01	Removed	Janu- ary 1, 2013	
----------------------	---------	-------------------------	--

SECR 2.02	Removed	Janu- ary 1, 2013	
----------------------	---------	-------------------------	--

SERV 0	Table of Contents Added: SERV 2.08 Insertion	De- cem- ber 1, 2014	Janu- ary 1, 2016
-------------------	--	-------------------------------	-------------------------

SERV 1	Requirements 5. Location 5. B.: Revised to "All new home construction residential gas meters shall be located immediately adjacent to an outside wall at a location readily accessible for emergency responders. The preferred location of the meter riser is within 2 to 5 feet of the front corner of the structure as long as the clearance requirements list below can be achieved. Alternate location would be the next closest point that meets clearance requirements. The gas meter can be installed on the front side of the home if agreed upon by Ameren Illinois and the property owner." 5. C.: New "Residential meter riser location for propane/electric conversion or an existing service line that is being replaced or relocated and/or replacement of existing service riser should be located in accordance with the following matrix:	De- cem- ber 1, 2014	Janu- ary 1, 2016
-------------------	---	-------------------------------	-------------------------

The matrix table was expanded by adding clearance requirements for Conversion from Propane and Conversion from Electric. Meter location for conversion customers do not have to meet the 2 to 5 feet from front corner preferred location.

Revisions were made to distinguish between service installed to a newly constructed home versus one installed to an existing home that is converting from electric or propane. These were reviewed and approved by the Gas Superintendents.

8. PE Service Lines

8. G.: New, "Service lines installed by plowing or boring operations should follow the procedures contained in BORE 2.03 - Pipe Installation and POLY 1."

Added to provide link to boring and pipe installation procedures.

8. I: New, "The casing pipe for the flex and rigid riser should not be shortened under any circumstances due to the potential of damaging the carrier pipe. The riser's twelve (12) inch pig-tail can be shortened but there must sufficient length remaining to allow for proper installation of the electrofusion coupling."

The casing pipe provides support and stability for the riser. The manufacturer does not recommend shorten the casing pipe.

9. Pressure Testing

9. A.: Added natural gas as an approved test medium.

9. D. Revised to "The results of the pressure test shall be recorded on the Service Card in ClickMobile."

12. Back-Flagging

12. B.: Revised to ""Yellow" locating flags, yellow headed stakes and/or yellow marking paint should be placed over the new facilities. There should be placement of enough flags/stakes to ensure that facilities are clearly identified as to route and location."

Added yellow headed stakes and yellow marking paint as other methods for back-flagging.

Removed the former 12. C. thru 12. E. which addressed; special areas of concern, exempted heavily paved areas and gas supervisor's determining where back-flagging is needed.

Damage Prevention group felt all newly installed facilities should be back-flagged.

13. Records

13. C.: Added that service should be mapped in the electronic mapping system within 90 days after submittal to Poster.

This is the commitment made in response to ICC's request that the O&M state how soon Ameren Illinois' maps are updated.

SERV 2.02	<p>Excess Flow Valves</p> <p>2. Installation</p> <p>2. A.: Revised to "On a distribution service, the EFV shall be installed as close as practical to the outlet of the service tee."</p> <p>2. B.: Revised to "An EFV shall be installed as close as practical to at the outlet of the service tee on residential high pressure distribution service line."</p> <p>Added "as close as practical" to provide flexibility where access to the service tee is impractical or not feasible, i.e. under pavement.</p> <p>2. D. Grammatical only, "above" replaced "these". "Exception to above locations must be approved by Gas Engineering personnel."</p> <p>3. EFV Sizing</p> <p>3. D.: New, "Where the inlet pressure is less than 20 psig and an existing service line is 120 feet or less with a customer's connected load is 330 cfh or less, a 1/2" PE pipe can be inserted through the existing steel service line. Upgrading to 1 inch would not be required in this case. See SERV 2.08 Insertion."</p> <p>Allows for inserting an existing service where there is confidence that the customer's current and future load can be handled by a 1/2 inch PE service line.</p>	<p>Janu- ary 1, 2014</p>	<p>Janu- ary 1, 2016</p>
SERV 2.03	<p>Farm Tap Installation</p> <p>1. C. New "A new farm tap shall only be installed within a service line that serves no more than two (2) service risers. A newly installed gas main shall not be connected to the downstream end of a newly installed farm tap."</p> <p>1. D. New "Once three (3) or more service risers are connected, the existing service line can no longer be classified as a service. The line shall either be upgraded to a main or replaced with a new main and the farm tap changed to a regulator station. An upgraded line shall meet the requirements contained in MAIN 1."</p> <p>Clarification that a farm tap is only installed on a service line. This is consistent with interpretation of the Part 192 code. Pressure regulation facility connected to a main is a pressure control station that requires annual inspection.</p> <p>3. Location</p> <p>3. A.: Inserted additional language regarding crossing adjacent property owner(s).</p>	<p>April 1, 2013</p>	<p>Janu- ary 1, 2016</p>

"Farm tap installations will normally be placed on the customer's property at or near the property line. In situations where the service installation would cross an adjacent property owner(s) an easement is normally required for the service line. If that easement allows, the farm tap can be placed on that property. The main goal is not to have a farm tap installed on public right-of-way."

3. B.: Inserted language regarding easements.

"On a long side service, the farm tap should normally be placed on the customer side of the road. However, if a private easement is obtained, the farm tap can be placed on the same side of the road as the gas main."

Reinforces the Company's position that farm taps should be on the customer's property but does provide for option if an easement can be obtained.

3. E.: Revised placement of pipeline marker, "Consideration should be given to installing pipeline marker at farm taps located in areas where vegetation growth may inhibit visibility. See PMRK 1"

In residential area or an area where the farm tap is located in a well-kept area, requiring a pipeline marker would have minimal benefit.

5. Inlet Valves

5. B.: Revised, "There are options available for installing below grade inlet valves depending on the size of the transmission or high pressure distribution supply line, location, ease of access and customer being served:

(1) For either design, an optional weld Mueller H-17900 valve can be installed in the service line. See SERV 3.06 or SERV 3.07 This valve should be installed in a location as close to the main as practical and in an area where a valve box can be maintained and easily located.

(2) A Mueller H-17800 curb valve tee can be installed as the service tap on the main in lieu of an AUTOPERF tee or H-17656 valve tee. For easy access, a valve box can be installed over this valve. See (4) below for AUTOPERF tee limitations.

(3) Similarly, a Mueller H-17656 valve tee can be installed as the service tap on the main in lieu of an AUTOPERF tee. However, as with the AUTOPERF tee, the valve tee would have to be uncovered in order to shut-off the gas flow. See (4) below for AUTOPERF tee limitations.

(4) Where the wall thickness of the pipe cannot be verified to be 0.281 inches or less, a Mueller H-17656 valve tee or Mueller H-17800 curb valve tee should be used in place of an AUTOPERF tee on transmission and high pressure distribution mains 6 inch nominal diameter and larger. See TAPS 2.05, SERV 3.06, or SERV 3.07 for more information."

5. C.: New "If there is a future possibility of upgrading the farm tap to a regulator station, consideration should be given to install either a Mueller H-17900 or a H-17800 as a station valve. The valve should be located a minimum of twenty (25) feet upstream of the farm tap inlet riser."

Revisions were made to clarify the various valves that can be installed on a main serving a farm tap and the limitations of an Autoperf tee.

SERV 2.07	<p>Gas Service GTech Mapping</p> <p>5. Farm Tap Services</p> <p>5. C.: Grammatical only, deleted since it was a duplicate to 5. A.</p>	De- cem- ber 1, 2014	Janu- ary 1, 2016
SERV 2.08	<p>Insertion</p> <p>Totally new section that was prepared by the Gas Standards Committee and reviewed by a SMR Team. This section covers:</p> <p>General</p> <p>Limitations</p> <p>Tracer Wire Installation</p> <p>Dead insertion Procedures</p> <p>Conduit or Sleeve Insertion Procedures</p>		Janu- ary 1, 2016
SERV 3.06	<p>Farm Tap - Single Cut - 60 - 450 PSIG Inlet Pressure</p> <p>Revised the Note below the Material List table.</p> <p>"Note: Item 1: Maximum wall thickness that Mueller H-18101 can tap is 0.281 inches. This limits the use of the 3/4" AUTOPERF to: (a) Schedule 40 pipe and under and pipe sizes 6 inch nominal diameter and smaller; or (b) Schedule 80 pipe and under and pipe sizes 2 inch nominal diameter and smaller. Therefore; if the pipe wall thickness is not known or cannot be verified through testing or experience to be less than 0.281, a Mueller valve tee, H-17656, or Mueller curb valve tee, H-17800, should be used in place of the AUTOPERF tee on 6 inch nominal diameter pipe and larger transmission lines and high pressure distribution lines. See TAPS 2.05 for maximum wall thickness for AutoPerf Service Tees.</p> <p>Schedule 40, 6 inch nominal diameter pipe has a design wall thickness of 0.280 inches which is why if the wall thickness of a 6 inch pipe is unknown an AUTOPERF tee should not be used. See STLP 2.01 for wall thickness of stock coded steel pipe."</p> <p>Revised in an attempt to better clarify the limitations of the Autoperf tee.</p>	Janu- ary 1, 2014	Janu- ary 1, 2016

SERV 3.07	<p>Farm Tap - Double Cut - 451 - 1000 PSIG Inlet Pressure</p> <p>Corrected the stock code for the following:</p> <p>Item 10:Tee, Pipe, 3/4" x 3/4"x 3/4", FS, Threaded, 3000 psig</p> <p>Item 12: Nipple, Pipe, 3/4"x 2", Schedule 80</p> <p>Item 23: Box, Valve, Gas (Optional)</p> <p>Revised the Note below the Material List table.</p> <p>Stock code correction for Item 10 and 12 was necessary to get the higher pressure fittings. The revised Note is the same as in SERV 3.06.</p>	Janu- ary 1, 2014	Janu- ary 1, 2016
STLP 0	<p>Table of Contents</p> <p>STLP 2.01 inserted new:</p> <p>2. Nominal Outside Diameter</p> <p>3. Nominal Wall Thickness</p> <p>STLP 2.02 added new</p> <p>5. Gel Filled Casing</p>	Janu- ary 1, 2014	Janu- ary 1, 2016
STLP 1	<p>Requirements</p> <p>12. Pipe Thread Sealers</p> <p>12. C. Approved Pipe Thread Sealers</p> <p>Removed 505 Key Tite, 8 oz, sealer from the approved list by the Gas Standards Committee due to a short shelf life.</p>	Janu- ary 1, 2013	Janu- ary 1, 2016
STLP 2.01	<p>Design Pressure</p> <p>1. Design Formula</p> <p>Removed "(actual as produced diameter)" from the Nominal outside diameter. A table has been added with Nominal Outside Diameters</p> <p>2. New: Nominal Outside Diameter</p> <p>"The nominal outside diameter (D) shown below are for commercial pipe in accordance with ASTM A53 and API 5L."</p> <p>A table was added that list the nominal outside pipe diameters for pipe sizes 3/4" thru 42"</p> <p>3. New: Nominal Wall Thickness</p> <p>(1) Nominal wall thickness (t) is shown in the Steel Pipe Stock Code Table below. Wall thickness for pipe not listed below, can be found in Pipe Fitters Handbook, ASTM A53, or API 5L.</p> <p>(2) If the wall thickness is not known, there are procedures contained in Part 192.109 that describes how to obtain the wall thickness through actual measurements.</p>	July 1, 2014	Janu- ary 1, 2016

(3) Additional wall thickness required to protect the pipe from anticipated external pressure or loads may not be included in computing design pressure.

These two items were added to provide additional information and to clarify the term "nominal".

7. Steel Pipe Stock Code Table

Gas Standards Committee and Gas Tech Engineering have updated the table to include all steel pipe that is currently stock by Ameren Illinois gas operations. Table was also updated to reflect going to all Min X52 Max X56 pipe for sizes larger than 2 inch.

8. Dual Coated Steel Pipe

Removed 8. D. that stated to contact Gas Standards and Materials personnel prior to ordering any dual coated pipe not listed in the Dual Coated Pipe table.

Removed the Dual Coated Pipe table since that pipe is now listed in the Steel Pipe Stock Code table in section 7.

STLP 2.02	<p>Casing Pipe Installation</p> <p>5. Gel Filled Casing - New</p> <p>5. A. "Gas Tech Engineering in consultation with Corrosion Control personnel will provide detailed plans and instructions on the gel filling procedures."</p> <p>A schematic of the fill operation is included.</p> <p>5. B.: "The enclosure and vent valve shown below are samples of the equipment that Gas Tech Engineering or Corrosion Control may want to be installed on the casing vent stacks."</p> <p>Picture of an enclosure for the probe and stack vent valve is included.</p>	<p>April 1, 2010</p>	<p>Janu- ary 1, 2016</p>
STLP 3.01	<p>Weld Fittings</p> <p>5. Caps</p> <p>Expanded and updated the table. Table is now divided into 3 section; Grade B, Y-52, and Y-60 caps. All the weld caps currently stocked by Ameren Illinois are listed.</p>	<p>July 1, 2014</p>	<p>Janu- ary 1, 2016</p>
STLP 3.02	<p>Reinforcing Saddles</p> <p>2. Installation</p> <p>2. A. Regular Type Reinforcing Saddle</p> <p>2. A. (4): Revised to, "Do not weld vent hole closed. Vent prevents gas build-up under the reinforcing saddle." Deleted "Plug vent hole with mastic."</p> <p>2. A. (5): New, "Coat with an approved coating material. See CORR 2.03 Coatings"</p>	<p>Janu- ary 1, 2014</p>	<p>Janu- ary 1, 2016</p>

2. B. Full Encirclement Reinforcing Saddle

2. B. (5): Revised to, "Do not weld vent hole closed. Vent prevents gas build-up under the reinforcing saddle." Deleted "Plug vent hole with mastic."

2. B. (6): "Coat with an approved coating material. See CORR 2.03 Coatings"

According to a manufacturer's information, reinforcing saddles are not designed to be a pressure containment fitting. The vent hole prevents gas build-up under the saddle.

Mastic is no longer an approved coating.

STLP 3.05	<p>Weld End Insulators</p> <p>Expanded and updated the tables to show all of the weld end insulators currently stocked by Ameren Illinois. Tables are divided into Class 300 and Class 600 rated insulators.</p>	<p>April 1, 2010</p>	<p>Janu- ary 1, 2016</p>
TAPS 0	<p>Table of Contents</p> <p>TAPS 2.02 - Updated</p> <p>5. Assemble Plugging Unit to Valve</p> <p>8. Remove Old Valve</p> <p>TAPS 2.05 - Updated</p> <p>3. Maximum Pipe Wall Thickness for AUTOPERF Tee</p> <p>TAPS 3.02 - Added</p> <p>7. Thread-O-Ring Fitting</p>	<p>Janu- ary 1, 2014</p>	<p>Janu- ary 1, 2016</p>
TAPS 1	<p>Requirements</p> <p>8 Testing</p> <p>8. B.: Revised to "A welded stopper fitting should be leak tested at the operating pressure of the line for a minimum of 10 minutes and the associated piping pressure tested in accordance with PTST 1. The final connections should be leak tested with soap solution at the operating pressure."</p> <p>Revised to be consistent with the revision in PTST 1.</p> <p>9. Tapping and Stopping/Completion</p> <p>9. E. Added "See PRES 2.03 Potential Over Pressurization or Service Interruption"</p> <p>"E. When using a bypass, or when there are two or more feeds into the area, a pressure gauge should be installed on the live side of each stopper fitting and monitored throughout the stopping operations. See PRES 2.03 Potential Over Pressurization or Service Interruption."</p> <p>When performing an operation where gas flow is being interrupted and there is a potential for an unplanned loss of service</p>	<p>July 1, 2014</p>	<p>Janu- ary 1, 2016</p>

to customers following the planning procedures in PRES 2.03 could minimize that potential.

TAPS 2.02	<p>Mueller No-Blow Valve Changer</p> <p>TAPS 2.02 was updated with the Mueller's most current instruction manual. There are some revisions in the instructions many of which provide a little more guidance. Pictures have replaced the drawing and in the pictures, the valve changer is oriented in a vertical position the same as it would be in actual operations. The instructions were revised to reflect this different orientation by using the words "up" and "down" instead of "forward" and "back". "Meter Valve" or "valve" replaces the term "stop" that was used throughout the previous instructions. Where lubrications is mentioned, added a reference to Mueller Rubber Stopper Lubricant.</p> <p>Training department already has the updated instructions.</p>	January 1, 2011	January 1, 2016
TAPS 2.05	<p>Mueller AUTOPERF Tee</p> <p>3. Maximum Pipe Wall Thickness for AUTOPERF Tee</p> <p>Revised the Notes under the table:</p> <p>1) "With the exception of the 1/2" x 1/2" H-18102, maximum wall thickness is 0.281 inches.</p> <p>2) This limits the use of the 3/4" AUTOPERF to:</p> <p>(a) Schedule 40 pipe and under and pipe sizes 6 inch nominal diameter and smaller; or</p> <p>(b) Schedule 80 pipe and under and pipe sizes 2 inch nominal diameter and smaller.</p> <p>3) Therefore; if the pipe wall thickness is not known or cannot be verified through testing or experience to be less than 0.281, a Mueller valve tee, H-17656, or Mueller curb valve tee, H-17800, should be used in place of the AUTOPERF tee on 6 inch nominal diameter pipe and larger transmission lines and high pressure distribution lines.</p> <p>4) Schedule 40, 6 inch nominal diameter pipe has a design wall thickness of 0.280 inches which is why if the wall thickness of a 6 inch pipe is unknown, an AUTOPERF tee should not be used. See STLP 2.01 for wall thickness of stock coded steel pipe."</p> <p>Attempted to better clarify the limitations of the AUTOPERF punch and the importance of knowing the pipe wall thickness before installing and AUTOPERF tee.</p>	January 1, 2013	January 1, 2016
TAPS 3.01	<p>Mueller Fittings</p> <p>3. Line Stopper Fittings</p> <p>Table for Use on Standard Wall Steel Pipe</p> <p>Removed the 4" x 3", H-17255, 275 psig, fitting.</p>	July 1, 2014	January 1, 2016

Fitting is no longer available.

Table for Use on Thin Wall Steel Pipe

Added 8", H-17275, 275 psig, Stock Code 19 33 040

TAPS 3.02	T.D. Williamson Fittings Added: 7. Thread-O-Ring Fitting A 2 inch fitting rated at 3600 psig, stock code 19 73 767	Janu- ary 1, 2011	Janu- ary 1, 2016
TAPS 4	Forms and Reference Materials Update Reference 01 - Mueller No-Blow Valve Changer Operating Instructions (Rev 01/15)	Janu- ary 1, 2014	Janu- ary 1, 2016
TURN 0	Table of Contents TURN 1: Added 2. Manufactured Homes TURN 2.01: Residential/Small Commercial Customer Revised section name 4. Existing Service Connect 6. Low Flow and Five (5) Minute Shut-in Test 8. Displacement of Air in Fuel Lines 11. Re-establishing Service After Flooding TURN 2.05 - Lighting Appliance - Water Heater Revised section name 5. Operational Check for Conventional Water Heater 6. Operational Check for High Efficiency Water Heater Added 7. Operational Check for Tankless Water Heater TURN 2.14 Changing Meter Valves New sections 3. Operating Property Line Valve 7. Installing Control Fitting Revised section headings 4. Changing of Meter Valves by Activating an EFV 5. Changing of Meter Valves by Excavating and Squeezing PE Pipe	Janu- ary 1, 2013	Janu- ary 1, 2016
TURN 1	Requirements	Janu- ary 1, 2011	Janu- ary 1, 2016

UNCONTROLLED IF PRINTED

The SMR Team rewrote this section to consolidate the information and separate out the Manufactured Homes. There are no significant changes to the requirements.

**TURN
2.01**

Residential/Small Commercial Customer

January 1,
2011

January 1,
2016

1. B. Merged the former 1. B and 1. C together

"All connected appliances shall be checked for proper installation and operation whenever the customer chooses to have Ameren Illinois relight the appliances. The installing contractor or his designee shall perform first time light-up on new or repaired appliances."

1. D. that addressed HUD Title 24 code was removed.

2. Care and Handling of Meters

2. B.: Revised to, "Meters being transported shall be in any upright secured position."

2. E.: Revised to, "Any meter that has been dropped or excessively jarred shall be tagged with an explanation and returned to the Meter Shop."

3. New Service Connect

3. A.: New inserted, "All new service connects require a check of regulator set pressure and lock-up."

3. B.: Revised to, "The gas meter should be installed at the same time as the service as long as the structure is framed out, the outlet of the meter bar should be:"

(1) Plugged or capped, and the meter valve left unlocked in the closed position or

(2) If customer piping and/or appliances have already been installed and a visual inspection of customer facilities has been performed to confirm appliance valves are closed or fuel line(s) is capped, gas meter bar may be connected to customer piping and the meter valve left unlocked in the closed position after a successful low flow and 5 minute shut-in test. Attach the Gas Meter Relight Tag."

Checking the regulator at the time installation is important to ensure the customer is getting the correct gas pressure and that the regulator is functioning properly. SMR Team provided additional guidance when a meter is installed for a new service.

4. Existing Service Connect (former Arriving at the Residence)

4. E. Customer Choice - Customer Relight Appliance

4. E. (1): Merged two previous sentences together, "When the customer chooses to relight their own appliances gas field personnel shall perform a low flow test and five (5) minute shut-in test on customer piping. See Low Flow and Five (5) Minute Shut-in Test section below."

4. E. (2): Revised to, "After the completion of a successful shut-in test, turn off the meter valve, leave meter valve unlocked and attach the Gas Meter Relight Tag."

4. E. (3): New inserted, "If customer is at home and available, the Meter Relight Tag should be given to the customer."

4. E. (4): New, "If customer is not available, leave a door hanger notifying customer their gas is ready to be turned on at the meter set."

SMR Team revised the wording to clarify the meter valve should be left unlocked and when customer is available the Meter Relight Tag should be given to the customer and not just hung on the meter set.

4. F. Customer Choice - Ameren Illinois Relight Appliances

4. F (1) (a): New, "Check to make sure access to the appliances is available. If not, leave a door tag advising customer to call to reschedule a connect."

SMR Team felt it is important to first check to make sure there are appliances available to relight before installing a meter.

4. F. (1) (b): Grammatical, added a reference to the Low Flow and 5 Minute Shut-in Test section.

4. F. (1) (c): Revised to, "If movement is detected, perform an investigation to determine source of movement." Removed "complete an inside leak investigation"

SMR Team felt there was no need to specify either an indoor or outdoor leak investigation. Gas field personnel would make the determination of what investigation was needed.

5. Low Flow and Five (5) Minute Shut-in Test

5. A.: Added "If odorant is not readily detectable, notify Gas Supervisor for a follow-up investigation."

Our insurance company representative recommended that our gas personnel check for sense of odor when they turn-on a customer's gas.

5. D. Using Gas Meter Test Hand

5. D. (1): Added "turn on gas", "Unlock meter valve, turn on gas. If fast movement on the test hand is detected turn the meter valve off and check for failed safeties and/or open fuel lines."

5. D (2): Revised to, "With the test hand on the upstroke perform the shut-in test. Refer to item (4) (a) and (b) below for meters equipped with remote meter reading modules."

According to the SMR Team members, the test hand needs to be on the upstroke.

5. D. (5), (5) (a): Just rearrange the original verbiage and put in bullet format

5. D. (5) (b): New, "If the customer is not home:

- Lock the meter valve and complete the OAS 6H screen, "Red Pin"
- Leave a door tag so the customer knows why their service is off and who to call to have service restored
- Document the finding in OAS."

SMR Team added to address situation when customer is not home.

5. D. (5) Note: Grammatical added Guidance on slight movement.

5. D. (6): New, "Soap meter set fittings and repair any leaks found."

SMR Team felt when gas field personnel leave the residence there should be no leaks on the meter set.

5. E. Using a Pressure Gauge Assembly

5. E. (7): Added "pressure gauge", "Turn the pressure gauge valve to the off position."

5. E. (9): Grammatical, "an investigation" replaced "a leak investigation", " If a slight loss in pressure is detected, ensure that the customer appliances have standing pilots and if not, perform an investigation and make any necessary repairs or issue a "Warning" tag."

5. E. (9) (a) & (b): New,

(a) If the customer is home:

- Ensure that customer appliances have standing pilots, if not
- Perform an investigation to determine source of movement
- Make simple repairs or Issue a "Warning" tag

(b) If the customer is not home:

- Lock the meter valve and complete the OAS 6H screen, "Red pin"
- Leave a door tag so the customer knows why their service is off and who to call to have service restored
- Document the finding in OAS.

SMR Team added this guidance to be consistent with the procedures under Using Gas Meter Test Hand.

6. Regulator Set Pressure and Lockup Check (Lockup replaced Shutoff)

6. A.: Revised to, "If the turn on includes a service regulator change, meter change or meter install, the turn on process will

also include a regulator set pressure and lock-up test using the following procedure."

6. A. (1) Note: Moved previous 6. C to a note under (1)

6. A. (4): Grammatical with word revisions, "The regulator should lock-up at no more than one (1) inch water column higher than the delivery set point of seven (7) inches water column."

6. A. (5): Grammatical with a couple of word changes, "Elevated delivery pressure customers will require a test gauge or better to set delivery pressure and check lockup of regulator. See METR 2.15 Elevated Meter Pressure and METR 2.22 Pressure Gauges."

7. Checking Fuel Lines

7. B.: Revised to, "If accessible, check where the fuel line enters the structure."

Previous 7. C & D. Removed checking access to appliances and verifying electric service in turned on since these are covered in other sections for TURN.

7. C. Revised tracing fuel lines to "Trace all visible fuel lines and check for code violations and hazards. See TURN 2.11 Warning Tag"

7. F.: Grammatical only, "Check each gas appliance for an accessible shut off valve or a listed gas convenience outlet installed in the same room/floor and within 6 feet of the appliance it serves. Existing appliances without a shut off valve may be lit, however a "Warning" tag should be issued."

7. G.: Grammatical only, "All water heaters and furnaces should have a sediment trap. Existing appliances without a sediment trap may be lit, however a "Warning" tag should be issued. Note: HUD does not require sediment trap (drip leg) at original appliances in Manufactured Homes."

7. H.: New, "Check for uncoated brass appliance connector(s) and replace when found. See TURN 2.15 Brass Appliance Connectors."

SMR Team revised some of the wording and merged some of the previous bullet points together. They felt that uncoated brass appliance connectors should be included.

8. Displacement of Air in Fuel Lines (replace Purging)

Throughout the section, "bleeding" replaced "purging".

8. C.: Grammatical, merged previous 8. C. & D., "The safest way to bleed a customer fuel line is at the gas stove but if not available can be bled at the water heater or furnace by holding down the pilot button to bleed the air through the pilot."

8. D.: Grammatical only added "any", "Overriding any appliance safety is an unsafe act and shall never be performed."

8. E. (4): Revised to, "When gas odor is first detected, tighten the fitting and soap test for leaks. With a gas detection instrument, check the area to ensure a hazardous atmosphere has not been created by bleeding the fuel line."

SMR Team wanted to clarify that once there is an indication of gas bleeding is when you check for leaks. The CGI should be used to check the surrounding area.

9. Lighting Appliances

9. A. Grammatical only, "When lighting a gas range complete a visual inspection and operational check of the range. See Lighting Appliance - Stove (Range) TURN 2.04."

9. B.: Grammatical only, "When lighting a water heater first verify that the water is turned on. If water does not come out of the hot and cold water faucet, do not light the water heater. Complete an inspection and operational check of the water heater. See Lighting Appliance - Water Heater TURN 2.05."

9. C.: Grammatical only, "When lighting a gas furnace complete an inspection and operational check of the furnace. See Lighting Appliance - Furnace TURN 2.06."

9. D.: Grammatical only, "Light any other existing gas appliances customer requests to be connected and complete an inspection and operational check of each appliance."

10. Crawl Spaces

10. B.: New, "If crawl space cannot be safely entered to light an appliance, notify Gas Supervisor so arrangements can be made to light the appliance or to get assistance."

SMR Team removed the list of hazardous atmospheric condition since they are contained in Confined Space section which is already reference in 10 A. and replaced the previous 10. C. and 10 D. with the new 10. B. statement.

11. Re-establishing Service After Flooding (Changed from Relighting Appliances After Flooding)

11. A.: Revised to, "If meter and/or regulator were underwater they should be checked for the presence water. If there is evidence of water, the component(s) should be replaced."

Clarified that if the meter and/or regulator had been underwater they needed to be checked and replaced if there is a presence of water.

12. Gas Meter Relight Tag

12. C.: Updated the relight tag with one that was revised in August 2015.

The SMR Team noted that previous tag did not tell the customer what to do if there was movement on the meter when the meter valve was turned on. The new tag tells the customer to turn the valve off and call Ameren Illinois.

13. Records

Revised by adding CSS, "Records associated with turning on gas service shall be recorded and maintained in Ameren Illinois CSS and OAS for at least two (2) years."

**TURN
2.02**

Large Commercial - Industrial Customer

January 1,
2013

January 1,
2016

2. Care and Handling of Meters and Correctors

2. B. Revised to be consistent with TURN 2.01, "Meters being transported shall be in an upright secured position"

5. Initiating Service

5. B.: Revised to, "Conduct a low flow test to ensure meter will register. Most large meter sets will have blow-down facilities downstream of meter that can be used to create flow through the meter. If odorant is not readily detectable, notify Gas Supervisor for a follow-up investigation."

Our insurance company representative recommended that our gas personnel check for sense of odor when they turn-on a customer's gas.

5. B.: Revised to, "Check meter set for leaks."

SMR Team removed "With customer valve closed" because in many cases there in no customer valve.

**TURN
2.04**

Lighting Appliance - Stove (Range)

January 1,
2011

January 1,
2016

2. Visual Inspection

2. A.: Revised to, "All new or replaced ranges shall have a shut off valve within 6 feet of the range and in same room."

2. B. (2): Revised to, "Existing ranges without a shut off valve may be lit, however a "Warning" tag shall be issued. See TURN 2.11 Warning Tag for list of Code Violations

Clarified the shutoff valve should be in the same room and a range without a shutoff valve is a code violation but can be lit.

3. Operational Check - Range Top Burners

Removed needing to check each burner air shutter, clean if necessary.

SMR Team indicated that accessing air shutter may not be possible or at best difficult. They felt that should be left to a qualified appliance repairman.

4. Operational Check - Oven Burner

4. B.: Revised to, "Equipment with an appliance safety, check for proper operation." Older model ovens may not have a safety.

4. B. (3): Revised to, "If you hear gas flowing through the orifice, the safety has failed. In this event, the range shall be turned off and a "Warning" tag shall be issued. See TURN 2.11

Warning Tag for Hazardous Conditions. No appliance shall be left in operation with a malfunctioning safety."

Clarification that Hazardous Condition is issued for a failed safety.

Removed needing to check oven burner air shutter, clean if necessary.

SMR Team indicated that accessing air shutter may not be possible or at best difficult. They felt that should be left to a qualified appliance repairman.

4. B (6): Revised to, "Turn on the oven burner control and check for proper ignition."

SMR Team wanted to remove all of the language regarding head position, main pilot and secondary pilot as they felt check for proper ignition was better.

4. C: Check for proper flame characteristics.

SMR Team removed the flame characteristic bullet points since they are covered in 5. Flame Characteristics.

5. Flame Characteristics

5. C. Revised to, "If the flame is lifting off of the burner or extending beyond the heating plate, there may be excessive gas pressure or combustion air."

Added "extending beyond the heating plated".

5. D.: New, "If proper flame characteristics cannot be obtained, issue a Warning Tag and isolate the appliance. See TURN 2.11 Warning Tag for Hazardous Conditions."

SMR Team added to be consistent with TURN 2.11 Warning Tag.

**TURN
2.05**

Lighting Appliance - Water Heater

July 1,
2012 Janu-
ary 1,
2016

4. Visual Inspection

4. C.: Grammatical only, removed "new or replaced water heaters" and made it simply "All water heaters". Did add that the shut-off valve should be in the same room.

C. "All water heaters must have a sediment trap before the control valve and a shut off valve within 6 feet and in the same room."

4. C. (1): Word change, "should" replaced "shall".

(1) "Existing appliances without a sediment trap or shut off valve may be lit, however a "Warning" tag should be issued."

4. E. (3): Added that high temperature flue vent tape can be used.

(3) "Single or double wall vent pipe joints are screwed or locked in place. High temperature flue vent tape can be used to secure the vent pipe joint."

4. F. (1): Added "no threads on outlet end".

(1) "The T&P Valve discharge pipe must be metal, terminates within 6 inches of the floor, and no threads on outlet end."

5. Operational Check for Conventional Water Heater - New name, Conventional Water Heater since high efficiency water heater and tankless heaters do not require the same checks.

5. A.: Simply rewording; "First, verify that the water is turned on. If water does not come out of the hot and cold water faucet, do not light the water heater."

5. C.: Added when inspecting burner assembly make sure it is suitable for operation. Removed "clean if necessary".

C. "Inspect condition of the burner assembly to ensure it is suitable for operation."

Team did not feel that our gas personnel should be responsible for cleaning the burner assembly. A qualified person should be performing that work and ensuring it is in suitable condition.

5. D: Remove the reference to Defective Equipment TURN 2.12 since it is cover in the Visual Inspection, 4. D.

D. "Check the appliance safety in the control valve for proper operation. See TURN 2.13"

5. F.: Reworded to "Verify that the pilot ignites the main burner completely. Check for proper flame characteristics."

"Caution: Position your head a safe distance away to prevent injury from possible flame rollout."

5. G.: Added "install inner door and jacket door"

G. "Turn the thermostat down to verify that the main burner shuts off, install inner door and jacket door."

Removed Former 5. L. "While the main burner is operating: Soap the fittings that connect the main burner and pilot tubes to the control valve"

5. I. (2): Revised wording to "Verify that the products of combustion are being vented outside through the use of such methods as: the hand, smoke from an extinguished match, etc."

Team revised to so other methods for verifying products are venting other than extinguished match could be used.

7. Operational Check for Tankless Water Heater - New section added.

A. "Water heaters shall be checked for operation by turning on the hot water faucet to allow the water heater to operate.

B. Then by turning the turning on the hot water faucet off to verify the water heater responds by shutting off.

C. Verify unit is venting properly."

SMR Team added procedures for tankless water heaters since they are becoming more common installations.

**TURN
2.06**

Lighting Appliance - Furnace

Janu-
ary 1,
2011

Janu-
ary 1,
2016

3. Visual Inspection

3. D.: Added "in same room", "All new or replaced furnaces shall have a sediment trap before the control valve and a shut off valve within 6 feet and in same room. Original furnaces in HUD manufactured homes may not have a sediment trap upstream of the furnace but should have a shut off valve."

Former 3. F. Removed checking model number for defective control valves

3. G.: Revised to "Inspect the furnace vent system: See Combustion and Ventilation Air TURN 2.08. See TURN 2.11 Warning Tag for Code Violation or Hazardous Conditions."

Remove 3. G. (1) thru (7) that listed venting items to inspect since they are in TURN 2.08.

4. Operational Check

4. B.: Added "if not previously done", "Turn the thermostat up as high as possible, if not previously done, and check the safety in the control valve for proper operation. See Appliance Safety and Thermocouple Tests TURN 2.13."

4. C. Revised to "Verify that the appliance valve is in the "off" position.

Note: Use the electric switch for the furnace control valve if available to control the ignition."

4. D.: Revised to "Light the pilot and turn the furnace control valve to the "on" position. Turn on the electric switch if utilized. Observe that the pilot ignites the runner tube, and that the runner tube ignites the burner(s) end to end."

4. F.: Added "characteristics", "With the blower off, continue to observe the flame characteristics from each burner."

Moved flame characteristic from 4. F.(1) & (2) to 6. Flame Characteristics

4. H.: Added "Verify that the products of combustion are being vented outside through the use of such methods as: the hand, smoke from an extinguished match, etc. If the furnace is not venting properly the furnace shall be shut off and a "Warning" tag issued."

4. L.: Deleted "combustion doors", "Re-install the furnace doors and return the thermostat to a normal setting for the season."

UNCONTROLLED IF PRINTED

4. M.: Deleted "combustion doors", "No furnace shall be left in operation without the furnace doors in place."

6. Flame Characteristics

6. C.: Revised to "If the flame is lifting off of the burner, there may be excessive gas pressure or combustion air."

Removed adjusting gas pressure at appliance or adjusting burner orifice.

6. D. & 6. E. are the flame characteristics from 4. F. (1) & (2).

6. F.: New, "If proper flame characteristics cannot be obtained, isolate the appliance and issue a Warning Tag, See TURN 2.11 Warning Tag for isolating an Appliance and Hazardous Conditions."

**TURN
2.09**

Venting

Janu- ary 1, 2011	Janu- ary 1, 2016
-------------------------	-------------------------

3. Venting Code

3. K. Gas dryers...

3. K. (1): New item: "Dryer exhaust shall not be connected into any gas vent, chimney wall, ceiling, attic, crawl space, or a concealed space of a building."

This is language is from the NFPA 54 code. NFPA 54 requires that gas clothes dryer be exhausted to the outdoors since the exhaust contains both combustion and moist air.

3. K. (2): Significantly revised to address the use of flexible metal vent material as a transition duct between the dryer and rigid exhaust duct.

(2) "Exhaust ducts shall be a rigid or UL listed flexible metal vent material. Do not use plastic or foil type vent material.

(a) Rigid metal duct material is required when vent passes through walls, ceiling or floors. The space around the duct shall be sealed with a noncombustible material.

(b) Flexible metal vent can be used as a transition from the dryer to the rigid metal duct.

(c) Flexible metal ducts are acceptable only if they are accessible for cleaning.

(d) Flexible metal vents must be fully extended and supported in the final dryer location. Remove excess to avoid sagging and kinking that could reduce airflow and poor performance.

(e) Flexible metal vents are not to be installed in or through enclosed walls, ceilings or floors."

Team added this material which comes from the NFPA 54 Code.

3. K. (3): Revised the duct assembly requirements to match NFPA 54.

(1) "Exhaust ducts shall not be assembled with screws or other fastening means that extend into the duct. External clamps or tape, such as duct tape, must be used to make connections."

Per NFPA 54, external clamps or tape must be used to make the joint connects for dryer exhaust.

**TURN
2.11**

Warning Tag

January 1,
2014

January 1,
2016

1. C.: Added "A copy of the Warning Tag is in TURN 4." This was added to eliminate the need for "See TURN 4" throughout the document.

2. Inspecting Customer Piping and Appliances

2. A.: Added "Part 3280 Manufactured Home Construction and Safety Standards" to identify where in the HUD Title 24 Code the standards are located.

4. Isolating an Appliance

4. A.: Revised to "Gas field personnel may isolate a hazardous condition at the at the appliance control valve, customer owned valve, meter valve or outlet of meter set." This is consistent with language in LEAK 2.01.

4. B.: Added "plug/cap outlet of meter", "Gas field personnel may shut-off the meter valve, disconnect/cap the meter set outlet, or plug/cap outlet of meter."

4. C.: Revised to "If the hazard is isolated at the meter valve, then the valve shall be locked, Red Pin, complete OAS 6H screen, and issue a Warning Tag". Gas field personnel should follow up to unlock the valve so customer or HVAC/plumbing contractor can relight the appliance(s)."

5. Code Violations

5. C. (2): Revised to "Advise customer to contact a qualified HVAC/plumbing contractor to have the code violation corrected."

5. C. (4): Revised to "Request that the customer sign the tag. If the customer refuses to sign the tag, turn tag into the Gas Supervisor."

5. D. Examples of Code Violations

5. D. (1): Added "damaged", "Deteriorated or damaged fuel line that does not adversely affect appliance operation."

5. D. (3): Added "improperly installed", "No sediment trap or improperly installed sediment trap on a furnace or water heater."

5. D. (6): Added "at least", "Horizontal vent pipe that is not sloped uphill at least 1/4" per foot."

5. D. (10): Added "interior wall", "Single wall vent pipe installed through floor, interior wall, exterior wall, or attic."

UNCONTROLLED IF PRINTED

5. D. (13): New, "Appliance operating properly but is located in an insufficiently sized confined space."

5. D. (15): New item that addresses CSST installation:

(a) CSST passing through furnace cabinet without protection from chafing

(b) CSST passing through masonry wall/foundation without sleeve

(c) CSST connected directly to outlet of meter set

(d) An exposed metal section of tubing outside

(e) Non pre-sleeved CSST installed underground without conduit

(f) Conduit vented inside

(g) Conduit not vented outside

(h) CSST connected directly to moveable gas appliance

The CSST SMR Team and the TURN SMR team recommended these items be added as Code Violations. CSST issues had not been previously addressed.

6. Hazardous Conditions

6. C. (3): Revised to, ""Advise customer to contact a qualified HVAC/plumbing contractor to correct the condition(s) as soon as possible."

6. C. (4): Revised to "Request that the customer sign the tag. If the customer refuses to sign the tag, turn tag into the Gas Supervisor."

6. D. Examples of Hazardous Conditions

6. D. (2): Added "valve", "A gas line/valve that is not capped or plugged."

6. D. (7): Moved from Code Violation, "Gas piping installed through air duct, gas vent, or chimney."

6. D. (8): Revised to, "Gas Appliance in a garage or in adjacent spaces opens to the garage where the burners and ignition devices are not at least 18" above the floor.

Exception: Water heater is listed as Flammable Vapor Ignition Resistant."

6. D. (9): Added broken chamber sight glass, "Missing combustion door (one or more) or broken combustion chamber sight glass."

6. D. (13): Moved from Code Violation, "Grills/louvers installed in the cold air return to the furnace in a confined space."

6. D. (15): Moved from Code Violation, "Deteriorated or damaged fuel line that prevents proper appliance operation."

- 6. D. (18): Moved for Code Violation, "Water heater with a reduced T&P valve or reduced discharge pipe."
- 6. D. (21): New, "Flexible plastic or thin foil vent tubing used to vent gas dryer."
- 6. D. (24): Revised to, "Vent pipe that is smaller than the appliance draft hood outlet or flue collar and does not meet the Vent Downsizing requirement listed in the NFPA 54 Code 13.1.2."
- 6. D. (25): Revised to, "Category 1, natural draft vent appliances sharing a common vent with Category 3 or Category 4 appliance."
- 6. D. (28): New, "Single wall vent pipe installed through unprotected combustible material(s), i.e floor, wall, ceiling, etc"
- 6. D. (30): Added "gas", "Plastic gas pipe used inside a structure or outdoors above ground."
- 6. D. (31): Added "mobile home", "An appliance installed in but not approved for mobile home or manufactured housing."
- 6. D. (33): New, "Vent-free appliance larger than 10,000 BTU in bedroom or 6,000 BTU in bathroom. NFPA 54 Code 10.23.1."
- 6. D. (35): New, "Commercial range must have a listed connector and restraint if on casters. NFPA 54 Code 10.12.6."
- 6. D. (36): New, "Inside regulator not vented properly. If designed with a vent limiter, the limiter must be facing upward."

SMR Team felt there were some previous Code Violations that should be moved to Hazardous Conditions and that there were some items that had not been previously addressed.

7. Customer Mailing

7. A.: Revised to, "If the customer refuses to sign or is not available the "Warning" tag, the Gas Supervisor or Ameren Illinois designee will send a letter with a copy of the original "Warning" tag to the customer of record addressing the code violation(s) or hazardous condition(s) encountered. In these cases, when the hazardous condition is entered on the customer's account the official letter can be printed from the Ameren Illinois CSS system. The letter is not signed by anyone at the generating location since the letter contains Ameren Illinois Customer Services contact information."

7. B.: Revised to "Sample of the CSS generated letter to customer:"

8. Records

- 8. A.: Replace "should" for "shall", "All Warning tag originals should be maintained by each Division for a period of 3 years."
- 8. B.: Added "Warning tag(s)", "Customer mailings should be filled with the original Warning tag(s) for future reference."

**TURN
2.14**

Changing Meter Valves

July 1,
2012

Janu-
ary 1,
2016

1. A.: Increased options for changing meter valves from five to seven methods. "This procedure identifies seven approved methods for changing meter valves while the service line is under pressure."

Moved the approved methods into a list format:

1. B.: The approved methods are:

- (1) Using meter valve changer, No-Blo
- (2) Operating property line valve
- (3) Activating an excess flow valve (EFV)
- (4) Excavating and squeeze polyethylene pipe
- (5) Excavating the service tee and closing the punch
- (6) Installing a control fitting
- (7) Changing a meter valve "on-the-fly" under specified pressure conditions.

Added Operating property line valve and installing a control fitting.

3. Operating Property Line Valve - New

A. Access and turn off the valve.

B. Verify the gas has been shut-off by slightly opening the meter valve.

4. Changing of Meter Valve by Activating an EFV - Added "Activating"

4. A. (5): New inserted, "Install vent piping to point the flow of gas away from the structure."

4. C.: New, "If the EFV fails to trip, notify Gas Supervisor for follow up investigation and corrective action if required. Utilize one of the other procedures to shut-off gas."

Removed the requirement for gas field personnel to wear their flash suit when performing this procedure.

SMR Team felt these two items needed to be added to provide additional guidance. The team also felt since the by-pass flow of gas is minimal there was no need for a flash suit.

5. Changing of Meter Valves by Excavating and Squeezing PE Pipe - Added "Excavating"

5. B.: Revised to, "In this situation or where this option is desired, the PE service line may be excavated and squeezed off. See POLY 2.02 Squeeze Off

7. Installing Control Fitting - New

A. Install fitting in accordance with procedures in TAPS 1

- B. Tap and stop fitting in accordance with manufacturer's instructions.
- C. Verify the gas has been shut-off by slightly opening the meter valve.

8. Changing of Meter Valves "On-The-Fly"

8. A.: Revised to "Changing a meter valve "on-the-fly" may be performed as outlined in the procedure below if conditions do not permit the use of a NO-BLO meter valve changer, utilizing an EFV, squeezing a polyethylene pipe, operating service tee or installing a control fitting."

SMR Team wanted to reinforce that utilizing "On-The-Fly" method is a last resort procedures when none of the others are possible.

**TURN
2.15**

Brass Appliance Connectors

Janu-
ary 1,
2011 Janu-
ary 1,
2016

3. Uncoated Brass Connectors Found In Service

3. B.: Revised to "Uncoated brass connectors found should be replaced by the gas field personnel with a stainless steel connector supplied by Ameren Illinois. The gas field personnel should explain to the customer why the replacement is necessary."

It is important that the customer be told of the potential hazard associated with these connectors and that is why the connector needs to be replaced.

3. C.: Replaced "will be" with "should be", "An approved appliance valve should also be supplied and installed with the stainless steel connector if such a valve is not already in place."

3. E." Replaced "completed" with "issued", "If the customer should refuse to have the uncoated brass connector replaced, a "Warning" tag shall be issued informing the customer the uncoated brass connector may be dangerous and that they refused to have the connector replaced free of charge."

3. G.: Revised to "The gas field personnel should properly discard the uncoated brass connector at their local headquarters or other Ameren Illinois facility."

**VALT
0**

Table of Contents

Janu-
ary 1,
2011 Janu-
ary 1,
2016

VALT 1 2.: Change the section name to Vault Inspection Requirements from Maintenance Requirements

VALT 2.01 2.: New section Vault/Pit Hazard Assessment and General Entry Requirements

**VALT
1**

Requirements

Janu-
ary 1,
2011 Janu-
ary 1,
2016

1. A.: Added "containing gas equipment".

A. "This section addresses the requirements for inspecting vaults or pits along with work to be performed in vaults or pits containing gas equipment."

By specifying the vault/pit contains gas equipment, PHMSA becomes the regulating agency not OSHA.

1. B.: Moved definition of Vault from VALT 2.01

B. "Vault is a subsurface structure housing piping and piping components that has a volumetric internal content of 200 cubic feet or more and constructed in such a manner that would allow gas to accumulate."

1. C.: Moved definition of Pit from VALT 2.01

C. Pit is a subsurface structure housing piping and piping components that has a volumetric internal content of less than 200 cubic feet and constructed in such a manner that would allow gas to accumulate

2. Change section name to Vault Inspection Requirements

Former 2. E.: Removed the statement regarding OSHA agreeing that PHMSA would regulate hazards associated with natural gas.

In CONF 1 there is already statement that PHMSA will regulate vaults/pits containing gas equipment.

**VALT
2.01**

Inspecting Vaults and Pits

1. B.: Revised to: "Refer to VALT 1 for distinction between a vault and pit.

Move the definitions that were originally in this section to VALT 1.

2. Vault/Pit Hazard Assessment and General Entry Requirements - This is new section that was added. It contains many of the items in the previous VALT 2.01 just rearranged.

2. A. (3): Added "Gas field personnel shall use only intrinsically safe equipment, or tools while in a vault or pit if a hazardous atmosphere, gas-in-air concentration of 30%LEL or greater, is present."

Added these safety items based on GTPC guidelines for Part 192.749 vault maintenance.

2. A. (5): Added "Compressed gas cylinders should not be brought into vault or pit"

These were safety items added by the Safety Specialists.

2. B. Air Testing - New section added

2. B. (1) The atmosphere of each vault or pit shall be tested 2.

B (1) (c): Added "Check the vault atmosphere at all levels of the vault or pit, using an extension hose connected to the gas

De-
cem-
ber 1,
2014

Janu-
ary 1,
2016

detection equipment. Allow the instrument readings to stabilize at each level before lowering the probe further."

Added these safety items based on GTPC guidelines for Part 192.749 vault maintenance.

2. B. (2): Added "If there is a possible source or indication of toxic gasses such as carbon monoxide or hydrogen sulfide, the atmosphere should be tested for the specific gas(s) prior to allowing anyone to enter."

Normally, the vault/pit atmosphere only needs to be tested for combustible gas and oxygen deficiency unless there is an indication the presence of other gases. However, current language implies checking all vaults/pits for CO.

2. B. (3): Added "Acceptable entry atmospheric concentrations, without additional PPE required, are as follows:

(a) Oxygen content between 19.5% and 21.5%.

(b) Gas-in-air concentration < 30% LEL.

(c) Carbon monoxide concentration < 30 ppm.

(d) Other toxic gas concentrations, below established threshold levels. Contact Safety Specialist for threshold level if necessary.

2. B. (4): Added "If acceptable entry conditions are not met the space should be ventilated. Forced air ventilation is generally preferred over exhaust ventilation."

2. B. (5): Added "Re-test the vault or pit atmosphere after ventilation to determine if it was adequate to bring concentration to within acceptable entry conditions"

Clarification on what is an acceptable entry atmosphere and a corrective measure that should be taken.

2. C.: Totally new section: Space Classification

C. "Space Classification

(1) Each vault or pit must be classified as either a Permit-Required Confined Space (PRCS) or non-PRCS, based upon the visual inspection and air testing results.

(2) If serious safety or health risks other than natural gas are present in the space (engulfment, entrapment, atmospheric other than natural gas, mechanical, electrical, etc.), and cannot be eliminated through ventilation or other means, the space must be considered a PRCS, and all entry must be in full compliance with the OSHA PRCS standard (29 CFR 1910.146), especially in regards to PPE, standby personnel, and retrieval/rescue procedures.

(3) If the vault or pit is classified as a PRCS contact a Safety Supervisor."

This section addresses whether a vault/pit is either a Permit-Required Confined Space (PRCS) or a Non-PRCS. The determi-

UNCONTROLLED IF PRINTED

nation is based on visual inspection and air testing results. If natural gas is the only hazard or risk based on the air testing, then the vault/pit would not be classified as a PRCS.

2. D. Totally new section: Entry Requirements Based on Air Testing

D. "Entry Requirements Based on Air Testing

(1) If, after ventilation, gas-in-air concentration < 30% LEL, but oxygen is not between 19.5% to 21.5% or the CO is more than 30 ppm, or toxic gas concentrations are above established threshold concentrations, then entry will not be performed until further measures are taken to improve air quality to acceptable concentrations.

(2) If, after ventilation, the only atmospheric hazard in the space is natural gas, then entry procedures must be in accordance with the VALT 2.01 2. B.(3) of this section.

(3) While employee(s) is in the vault or pit, the vault or pit atmosphere will be continuously monitored"

If there are other hazards; oxygen deficiency, excessive CO, or other toxic gases, additional corrective measures must be taken to bring the atmosphere into acceptable range.

3. Working in Gaseous Atmosphere

3. A.: " Revised to "For atmospheres where natural gas is the only atmospheric hazard, the following procedures will be followed:

(1) If gas-in-air concentration is 30% LEL or more but less than 60% LEL, then entry may be made with Level 1 PPE. See WWBG 2.01

(2) If gas-in-air concentration is more than 60% LEL, and the facility cannot be taken out of service, entry may be made only with Level 2 PPE: a Level 2 suit, supplied-air respiratory protection, and a full-body harness and retrieval device. See WWBG 2.01"

This section was completely revised by the SMR team. In order to eliminate confusion the team felt we should reference WWBG section of the O&M and use the same language from that section. The important point is these procedures only apply when natural gas is the only atmospheric hazard.

4. General Vault and Pit Inspection Items

4. A.: Added "through monitoring with CGI"

A. "If gas is found in the vault or pit through monitoring with a CGI, piping and equipment should be checked for leakage. Any leaks found should be repaired."

Reinforces that the vault/pit atmosphere is to be checked with CGI.

4. F. Added "ClickMobile"

F. "Report all deficiencies found on the Regulator Station or Valve Inspection forms within ClickMobile."

5. Vault Inspection Items

5. I.: Added "ClickMobile"

I. "All deficiencies found during the inspection shall be reported on the appropriate Regulator Station or Valve Inspection forms within ClickMobile."

The above two items were missed in the December 1, 2014 update that was devoted to the GCAM process.

VALV 0	Table of Contents	Janu- ary 1, 2011	Janu- ary 1, 2016
	Reference Materials Added		
	Reference 05 - Cameron Type 31 Install, Operate, Maintenance Manual		
	Reference 06 - Grove B5, 4B, 4C Installation, Maintenance Manual		
	Reference 07 - Cameron B5 Installation, Maintenance Manual		

VALV 2.01	Valve Installation	De- cem- ber 1, 2014	Janu- ary 1, 2016
	1. D.: Added "Distribution Design Center", "Gas Engineering or Distribution Design Center will provide the designation and location of emergency and non-emergency valves within the distribution system."		
	5. Non-Emergency Valves		
	5. C.: Revised to : "The location of these valves will be determined by the Gas Engineering, Gas Supervisor, Distribution Design Center or Gas Tech Engineering." Added the Distribution Design Center.		
	5. D.: New inserted, "As a guideline for placement of these valves, serious consideration should be taken for placement of a valve(s) in the following locations:		
	(1) An entrance to a subdivision where a distribution main being installed.		
	(2) Entrance to a dead end street with a cul-de-sac that is not part of a subdivision.		
	(3) Entrance to a subdivision cul-de-sac that has more than thirty (30) houses.		
	(4) Within a main segment such that no more than three hundred (300) customers would be isolated by a set of valves."		
	Gas Standards Committee developed consideration guidelines on where valves should be located when designing a project that involves installation of new or replacement gas main/ pipelines.		

VALV 2.03	<p>Plug Valve Maintenance</p> <p>9. Plug Valve Lubrication Extension</p> <p>9. H.: Revised to "Protect rod and all exposed threads with a cold applied tape, i.e. cold applied wax tape." This replaced coating with mastic since mastic is no longer an approved coating material.</p>	October 1, 2011	January 1, 2016
VALV 3.02	<p>Steel Ball Valves</p> <p>4. Full Port Ball Valves: Weld End</p> <p>Removed a note that was left in by mistake "Used This section provides Ameren Illinois stock codes along with manufacturer' specifications and dimensions.</p>	January 1, 2011	January 1, 2016
VALV 4	<p>Forms and Reference Materials</p> <p>Added</p> <p>Reference 05 - Cameron Type 31 Install, Operate, Maintenance Manual</p> <p>Reference 06 - Grove B5, 4B, 4C Installation, Maintenance Manual</p> <p>Reference 07 - Cameron B5 Installation, Maintenance Manual</p>	January 1, 2011	January 1, 2016
WELD 0	<p>Table of Contents</p> <p>WELD 2.04 - In-Service Welding changed from Maintenance Welds</p> <p>WELD 3.01 - Post-Weld heat Treatment was removed</p> <p>WELD 4 - Reference Materials</p> <p>Updated all 51 welding procedures and have separated the welding procedures (WPSs) from the qualifying welding procedures (WPQRs). WELD 4 now contains only the actual welding procedures (WPSs).</p>	January 1, 2013	January 1, 2016
WELD 1	<p>Requirements</p> <p>3. Welding Procedures Qualification Record (WPQR)</p> <p>3. C.: Added "The WPQRs will be maintained by the Ameren Illinois Gas Training section."</p> <p>3. D.: New: "The welding procedures, WPSs, are in WELD 4 reference material. New or updated welding procedures approved by the Gas Standard and Procedures may be utilized prior to being published in the O&M. These new or updated procedures will be published in the next O&M update."</p> <p>The welders, Company and contract, are required to follow approved welding procedures (WPSs). It is not necessary for them to have the qualifying procedures (WPQRs) thus the reason for separating the two. During the course of the year, situ-</p>	January 1, 2014	January 1, 2016

ations/conditions arise that may require development of new procedures for a specific project. The use of these new procedures may not correspond to O&M update schedule. When a new procedure is approved by Gas Standards & Procedures personnel, that procedure may be utilized.

3. E.: New "Contractor(s) or fabrication shop(s) may have their welding procedures reviewed and approved by the Gas Standards and Procedures group. See WELD 2.03 Construction of Pipelines and Piping Systems."

Approved contractor or fab shop welding procedures will not be included in WELD 4 but will be kept by the Gas Training section and Gas Standards & Procedures section.

**WELD
2.01**

Safe Welding Practices

Janu- Janu-
ary 1, ary 1,
2014 2016

5. Supervisor's Role

5. A. (5): Added reference to CONF 1; "Determine whether the work will be conducted in a confined space in accordance with Company procedures. See CONF 1"

8. Protection of Personnel

8. A. (3): New "Welding in Excavations: When welding in an excavation/trench, all requirements on the Excavation Safety (EXCV) section shall be followed to protect workers from excavation related hazards, including cave-ins. Welders working in excavations will also be protected from accumulation of welding fumes as specified in the ventilation section below."

Added to address welders working in an excavation.

9. Ventilation

9. A.: Remove "brazing"; "Adequate ventilation (natural or mechanical) must be provided for all welding and cutting related operations".

9. C.: Revised to: "The atmosphere of the area where welding or cutting is to be performed should be checked with a gas detection instrument, as necessary, to ensure the atmosphere is non-hazardous and is not oxygen deficient. The check must always be conducted when performing these operations in confined spaces."

Added checking the atmosphere when welding in a confined space. Remove brazing since Ameren Illinois gas operations does not do brazing.

9. E. Mechanical Ventilation

(1) Ameren Illinois Safety Specialist should be contacted when a question arises regarding the requirements for mechanical ventilation.

(2) Mechanical ventilation must be used when welding and cutting indoors or in confined spaces and must be used as

necessary in excavations in order to maintain adequate air quality.

(3) Mechanical ventilation consists of general room ventilation or local exhaust ventilation.

(4) Local exhaust ventilation is preferred, with the following precautions taken:

(a) The system shall be of sufficient capacity and so arranged as to remove fumes and smoke at the source and keep the concentration of them in the breathing zone within safe limits.

(b) Local exhaust ventilation shall consist of freely movable hoods intended to be placed by the welder as close as practical to the work.

(c) The exhaust from the system must be situated to insure that the welding fumes and smoke are not dispersed to other work areas or re-entrained into the make-up air of the building.

(5) If general mechanical (general room) ventilation is used, the following conditions must be met:

(a) Space of more than 10,000 cubic feet, per welder in an enclosed area (i.e., a building).

(b) Ceiling height is more than sixteen (16) feet.

(c) Welding is not done in confined space such as tanks, etc.

(d) Welding space does not contain partitions, balconies, or other structural barriers that significantly obstruct cross ventilation.

(e) The welding area is maintained generally clear of visible welding fume and the welding area is sufficiently separated from adjoining areas of the building to prevent welding fumes from moving into those areas

Expanded this section to provide more requirement details for mechanical ventilation. Safety Specialist provided this information based on OSHA requirements.

10. Equipment

10. C. Hoses

10 C. (5): Added "Cutting and welding torches should be fitted with an anti-flashback check valve."

Safety item added.

10. E. Electrode Holder

10. E. (3): Added a single word "electrode"

(3) The Ameren welding inspector may require the use of insulated electrode holders for specific applications.

WELD 2.02	<p>Welder Performance Qualifications</p> <p>5. Qualification Categories (Initial Test)</p> <p>5. B. (3): IN-SERVICE replaced MAINTENANCE</p> <p>5. C. Pipeline - Single Qualification (Butt/Branch welds)</p> <p>5. C. (2) (b): Corrected wall thickness to less than 0.188.</p> <p>8. Welder Re-Qualification</p> <p>8. D. Annual Requalification Test</p> <p>8. D. (2) Table: Changed Pipe Size for Butt Weld to 4" or greater from equal to 4"</p> <p>8. E.: In-Service Welders replaced Maintenance Welders</p>	<p>Janu- ary 1, 2014</p>	<p>Janu- ary 1, 2016</p>
WELD 2.03	<p>Construction of Pipelines and Piping Systems</p> <p>2. Codes and Standards</p> <p>2. C.: Deleted "latest edition" from API 1104.</p> <p>The edition of the API 1104 Code that we must follow is the edition PHMSA has incorporated in Part 192 by reference which may not be the latest edition.</p> <p>3. Material Requirements</p> <p>3. B. Fitting Requirements</p> <p>3. B. (1): Revised the tolerance in the beveled angle to + 7-1/2 degrees from +5.0 degrees.</p> <p>3. B. (5): Added "New": "New steel pipe shall be legibly marked and readable so that proper welding procedure can be used"</p> <p>4. Welding Procedure Qualifications (WPQR)</p> <p>4. B.: Deleted "latest edition"; "The quality of the welding procedure welds shall be determined by destructive testing in accordance with API 1104."</p> <p>4. C.: Replaced Section 5.0 of API 1104 with "Qualifications of Welding Procedures for Welds Containing Filler-metal Additives" in API 1104"</p> <p>Former 4. D. was deleted</p> <p>4. D.: Revised to "A welding procedure shall NOT be used for pipeline construction or for repair welding prior to its approval by Gas Standards and Procedures personnel."</p> <p>Removed Gas Code Compliance Group and Gas Training Department.</p> <p>Former 4. F, 4. G. and 4. I. have been deleted</p> <p>4. E.: Added WPSs are in WELD 4 and language addressing new or updated procedures; "All welding will follow the Welding Procedure Specification (WPS) that has been proven by a</p>	<p>July 1, 2012</p>	<p>Janu- ary 1, 2016</p>

Welding Procedure Qualification Report (WPQR). Ameren Illinois' welding procedures' (WPS's) are included in WELD 4. However, new or updated WPS's may be approved subsequent to this publication, see WELD 1."

Between O&M updates, new welding procedures may need to be qualified or updated and implemented before the next update.

4. F.: New: "A contractor or fabrication shop may submit their own procedures for review by Ameren Illinois' welding instructor and approval by the Gas Standards and Procedures personnel. The approved welding procedure shall be adhered to at all times while the contractor or fabrication shop is performing welding operations for Ameren Illinois. A copy of the approved welding procedure(s) will be maintained by Ameren Illinois' welding instructor and the Gas Standards and Procedures group."

Ameren Illinois can approve a contractor's or fab shop's welding procedure for use on an Ameren project. These procedures will be maintained separately and not included WELD 4.

5. Welder Qualification

5. D.: Replaced "section 6 of API 1104" with "Qualification of Welders" in API 1104 and "maintenance welding" with "In-Service Welding".

6. Welding Process and Controls

6. C. New, "The pipe and/or fitting(s) must be free of moisture prior to and during welding operation."

7. Pre-alignment Inspection

7. B. Pipe Wall Discontinuities

7. B. (4) (a): Added "For API 5L wall thickness tolerances see Table 9 and Table 11 in WELD 2.10 Arc Burn Removal."

(4) Gouges, Grooves, Scratches and Notches

(a) "All gouges, grooves, scratches and notches that exceed the requirements of API 5L shall be eliminated by grinding, providing the wall thickness is not reduced to below the minimum requirements. For API 5L wall thickness tolerances see Table 9 and Table 11 in WELD 2.10 Arc Burn Removal."

8. Welding Requirements

8. B. Line-Up and Fit-Up of Butt Welds, majority of this section was rewritten.

B. Line-Up and Fit-Up of Butt Welds

(1) External line-up or internal clamps should be used to assure proper alignment for butt welds greater than two (2) inch nominal diameter, unless it is impractical due to dimensional differences such as flange or fittings to pipe, fitting to flange,

(etc.) then the pipe will be firmly supported to prevent movement.

(2) External line-up clamps (for butt welds) may be removed before the complete root bead is applied, provided the line pipe is not unduly stressed and it is securely supported and tack welded.

(3) Root bead segments shall be approximately equal length segments spaced around the circumference of the joint.

(4) When conditions make it difficult to prevent movement of the line pipe, or if the line pipe weld will be unduly stressed, then approximately fifty percent (50%) of the root bead should be uniformly spaced around the circumference of the pipe before the line-up clamp is released or removed.

(5) The clamps shall remove out-of-roundness and shall provide a uniform joint fit-up. High-low conditions on equal wall thickness pipe should not exceed three-thirty seconds (3/32) of an inch.

(6) When an internal alignment clamp is used for achieving alignment it shall be held firmly in position until the root pass is approximately ninety percent (90%) completed and the line pipe has been properly supported.

(7) Root Opening shall have a uniform spacing throughout the circumference of the joint. The spacing shall be in accordance with the approved welding procedure. Minor root opening adjustments are permitted after installation of a root bead segment to maintain root opening tolerances. Adjustments to the root gap greater than 1/8th inch on weld assemblies is not allowed unless the root bead segment is replaced.

The welding trainer and welding SMR team revised this section in response to issues regarding when line-up clamps can be removed raised by an ICC inspector.

8. F. Transition Joints

8. F.(1): Added "not less than 12 inches minimum"

(1) "The transition between pipe ends of unequal thickness shall be by mechanical tapering, or by welding in accordance with ASME B31.8 or by means of a prefabricated weld transition fitting not less than twelve (12) inches minimum or one and one-half (1 1/2) pipe diameters in length. See STLP 3.03 Weld Transition Fittings"

(1) New: "When a transition taper is required in the pipe and/or fitting, it shall be made using a mechanical end preparation machine or by manual preparation. Taper shall meet the requirements contained in unequal wall thickness section below."

Added to be in compliance with API 1104.

8. P. Filler and Finished Beads

8. P. (4): Added "and inspected", The completed weld shall be thoroughly brushed, cleaned and inspected."

8. Q. Inter-pass Cleaning and Removal of Visual Defects

8. Q. (1): Replaced "buffer wheels" with "wire wheels:.

(1) "Each pass of the weld metal shall be cleaned of slag or remaining flux using hand or power tools with wire wheels before a further pass is applied."

8. R. Arc Burns (DOT 192.309)

8. R. (1): Added reference to WELD 2.10 Arc Burn Removal.

(1) "Arc burns shall be eliminated in accordance with the approved arc burn removal procedure. DOT 192.309 (c). See WELD 2.10 Arc Burn Removal"

8. R. (2): Removed Tables 9 and 11 and referenced their location in WELD 2.10.

(2) In the event that the remaining wall thickness is less than the minimum specified in API 5L, 43rd edition Table 9, (for pipe manufactured before 2009) or 44th edition Table 11 (for pipe manufactured in 2009 and after) shown herein, the pipe shall be cut-out as a cylinder. See WELD 2.10 for Table 9 and Table 11.

8. U. Pipe Coating Protection, replaces "shall" with 'should"

"The pipe coating (if any) should be protected from weld spatter and mechanical abrasion during welding."

8. W. Identification of Welders, changed from Identification of Multiple Welders. Replaced "shall" with "should".

"Each welder should mark the weld or section of weld for which he has been responsible with the identification assigned to him by the welding inspector using a weatherproof permanent ink or paint marker."

8. X. Weld Repairs

8. X. (1); Replaced "radiographic" with "non-destructive" and removed "welding inspector may require".

(1) "Depending on the extent of defective weld areas found during nondestructive examination, the weld may be cut-out as a cylinder of pipe or be repaired in accordance with the following limits:"

8. X. (2): Deleted "in a manner acceptable to the welding inspector".

(2) Before the above repairs are made, the defective area shall be entirely removed to clean metal by grinding."

8. X. (4): Revised to:

(4) "All repair cavities shall be not less than 2 inches in length and repaired with a minimum of two passes."

UNCONTROLLED IF PRINTED

8. X. (8): Removed Section 9 of API 1104. Latest Edition"

(8) "All repairs shall meet the Acceptance Standards for Non-destructive Testing of API 1104."

8. Z Revised to "When welding on pipe diameters greater than or equal to 16 inches two welders should be used to complete the root bead and hot pass. One (1) welder can then complete the fill and cap passes."

8. AA.: "On pipe diameters less than 16 inches one welder may be used."

Welding SMR team made this revision since it is allowed in API 1104.

9. Inspection of Welds

9. B. Visual Weld Inspection, replaced "Section 9.0, API 1104, Latest Editions".

"Visual inspection of welds will be conducted to insure that the welding is performed in accordance with the approved welding procedure (WPS) and the welding meets the requirements of this specification including Acceptance Standards for Nondestructive Testing of API 1104. See WELD 2.05 Visual Inspection"

9. D. Standard of Acceptability, replaced Section 9.0 API 1104 (Latest Edition).

"Unless specified otherwise, the standard of acceptability for the radiographic film interpretation of all regulated pipeline or piping system welds shall be Acceptance Standards for Non-destructive Testing of API 1104."

**WELD
2.04**

In-Service Welding (formerly Maintenance Welding)

Throughout this section the term "maintenance welding" has been replaced with "in-service welding".

Janu-
ary 1,
2013

Janu-
ary 1,
2016

6. Welding Procedures

6. (3): Revised by adding reference to WELD 4, "The in-service welding procedure (WPS) to be used will be those contained in WELD 4 and designated with the "IS" prefix, unless specified otherwise."

**WELD
2.06**

Radiographic Examination

2. Codes and Standards

2. B.: Added "accepted by PHMSA"

B. "American Petroleum Institute (API), Standard 1104, Latest Edition accepted by PHMSA, "Standard for Welding Pipelines and Related Facilities."

2. C.: Added "accepted by PHMSA"

Janu-
ary 1,
2012

Janu-
ary 1,
2016

C. "American Society of Nondestructive Testing (ASNT), Recommended Practice No. SNT-TC-1A, Supplement A, Radiographic Testing Methods, Latest Edition accepted by PHMSA."

2. D.: Added "accepted by PHMSA"

D. "American Society for Testing Materials (ASTM), E-E94-04 - Radiographic Testing, Latest Edition accepted by PHMSA."

3. Radiographic Inspection Personnel

3. A. Personnel Qualification

3. A. (1): Added " shall be qualified and certified to Level 1, II, or III of ASNT SNT-TC-1A, Latest Edition accepted by PHMSA"

"All regularly assigned radiographic personnel shall meet the requirements as defined in ASNT Recommended Practice; and shall be qualified and certified to Level 1, II or III of ASNT SNT-TC-1A, Latest Edition accepted by PHMSA, Supplement A and NRC and/or State Regulations for radiation safety."

3. A. (4) Records of certification for radiographers and interpreters

(d) 3. A. (4)(d): Revised to "A current vision acuity records administered by an approved source of the Radiographer's Jaeger J-2 and color discrimination eye examination.

3. A. (6): Revised to "In addition, film interpreters may be required to review this document and demonstrate their knowledge and understanding of this procedure prior to production film interpretation."

3. A. (7): Revised to "Radiographers may be required to demonstrate their ability to produce acceptable radiographs with each radiographic procedure they use prior to performing production radiographs."

3. B. Training Requirements

3. B. (1): "Moved some wording around "Prior to assignment, the Contractor shall train radiographic trainees to Level I in the use of radiation monitoring equipment."

3. C. Certification

3. C. (5); Employee Number replaced Social Security Number

4. Radiographic Procedures

4. B. Level of Quality

4. B. (1): Revised to "Image Quality Indicators (IQI), penetrameter, shall be placed on the weld prior to radiography and various attributes must be visible when viewing the resulting film."

4. B. (2): Revised to "The procedures shall produce radiographs of sufficient density, clarity, etc to provide the image of the essential wire diameter and ASTM set letter."

UNCONTROLLED IF PRINTED

4. B. (3): New "Ameren Illinois utilizes the ASTM Image Quality Indicator"

4. C. Radiographic Procedure Details

4. C. (4): Film Density

4. C. (4)(a): Changed film density 2.0 to 4.0 from 1.8 to 3.0.

(a) "Film shall be exposed so that the H & D density shall not be less than 2.0, or more than 4.0 through the thickest portion of the weld."

4. C. (6): New "Film Limitations

(6) Film Limitations

(a) "When radiographic source is outside but not more than a half (1/2) inch from the weld surface at least three exposures separated by one hundred twenty (120) degrees shall be made for radiographic inspection of the completed weld.

(b) When the radiographic source is outside and more than half (1/2) inch from the weld surface at least four (4) exposures separated by ninety (90) degrees shall be made for radiographic inspection of the completed weld."

4. C. (7) Penetrameters

4. C. (7)(a): Spelling and typo corrections, "API penetrameters made of radiographically similar material to the weld being inspected shall be used."

4. C. (7)(b): Revised to "The thickness and location of the penetrameters shall be in accordance with API 1104, Latest Edition shown the following table.(Table 5 of the 20th edition)"

Added a Table for Weld Thickness Versus Diameter of ASTM E747 Wire Type IQI from API 1104.

4. C. (8) Shims, completely revised

(a) "When penetrameters are not placed directly on the weld reinforcement due to restricted areas or if required to be placed off the weld so as not to mask relevant discontinuities the wire shims of radiographically similar material will be utilized to simulate the average reinforcement (build-up). The film density through the shim and the penetrometer must meet the density and essential wire requirements stated in API 1104, Latest Edition accepted by PHMSA."

4. D. Qualification Procedures

4. D. (5): Revised to "Ameren Illinois representative may review all procedure details and the test results prior to beginning testing."

4. D. (6); Changed "approved" to "accepted"; "Qualification Form provided by the Radiographic Contractor and accepted by Ameren Illinois.

5. Production Radiography

UNCONTROLLED IF PRINTED

5. C. Equipment for Interpretation

5. C. (b). Change film density to 4.0 from 3.5.

(b) "The viewer shall produce a sufficient illumination to view a maximum film density of 4.0."

5. D. Standards of Acceptability

5. D. (1) Film Interpretation

5. D. (1)(a): Added "porosity charts from API 1104, 20 edition shown below"

(a) "The standard of acceptability for radiographic film interpretation shall be API 1104 and the porosity charts from API 1104, 20th edition shown below."

5. D. (1)(b): Added " Maximum Distribution of Gas Pockets: Wall Thickness Less Than or Equal to 0.500 in. (AP1104)"

5. D. (1)(c); Added "Maximum Distribution of Gas Pockets: Wall Thicknesses Greater than 0.500 in (API1104)"

5. E. Daily Radiographic Reports

5. E. (3) The daily radiographic report

5. E. (3)(j): Inserted new, "Type of Exposure; Single Wall Exposure/Single Wall Viewing (SWE/SWV) or Double Wall Exposure/Single Wall Viewing (DWE/SWV)"

WELD
2.07

Dry Magnetic Particle Inspection

1. General

1. A.: Revised to "This section defines the requirements for performing a Visible Dry Magnetic Particle Inspection (Yoke/ Prod Methods) for Pipeline and Related Facilities Weld (hereafter referred to as "VDMPT") of pipe groove and fillet welds for detection of cracks and other discontinuities open to the surface using the dry powder method. The continuous test method should be utilized."

Provided the actual name of the inspection method versus the generic term magnetic particle.

1. D.: Inserted new; "Ameren Illinois does not allow magnetic particle examination on surface areas that are coated or painted."

2. Inspection Personnel: Revised to include certified:

"All personnel performing and interpreting the results of the magnetic particle examination shall be qualified and certified in accordance with the American Society of Nondestructive Testing (ASNT), "Recommended Practice No. SNT-TC-1A Latest Edition accepted by PHMSA," Level II (MPT),"

3. Equipment

3. A. General

January 1,
2012

January 1,
2016

3. A. (1): Added the code to which the power must comply.

(1) Commercial grade, dry magnetic particle powder complying with the requirements of ASTM E709-08 and have the properties required by AMS 3040 shall be used, red or grey in color, whichever provides the maximum contrast with the surface being examined.

3. A. (4): Insert new: "Visible light intensity for visible magnetic particle examination shall be one hundred (100) foot candles minimum at the surface of the test area.

3. B. Yoke Method

3. B. (1): Changed lifting force to 50 lbs. from 40 lbs.

(1) "A portable D.C. magnetic yoke capable of a lifting force of 50 Lbs. at a 6" spacing shall be used."

3. B. (2): Inserted new, "Dead weight checks should be performed at a minimum every six (6) months.

4. Inspection Procedures

4. B.: Inserted new, "Examination temperature of the test area shall not exceed 600° F during final inspection."

5. Standards of Acceptability

5. A.: Revised to "All relevant indications shall be evaluated in accordance with API 1104, Acceptance Standards for Nondestructive Testing, Latest Edition accepted by PHMSA, and the porosity charts from API 1104 20th edition, except that no crack regardless of length is acceptable."

5. B.: Inserted new "Porosity charts from API 1104 are shown below.

5. B. (1): New porosity chart, "Maximum Distribution of Gas Pockets: Wall Thickness Less Than or Equal to 0.500 in.(API 1104)"

5. B. (2): New porosity chart: "Maximum Distribution of Gas Pockets: Wall Thicknesses Greater than 0.500 in (API1104)"

6. Reports

6. A.: Significantly expanded to include a list of 12 items that should be included in the report. List is too long to show here.

**WELD
2.08**

Liquid Penetrant Inspection

1. General

1. A.: "Minor change in title of process, This section covers the recommended procedures for the Visible, Solvent Removable Inspection for Pipeline and Related Facilities Welds of pipeline maintenance groove and fillet welds, hereafter, referred to as Liquid Penetrant Testing (LPT)."

2. Codes and Standards

Janu-
ary 1,
2012

Janu-
ary 1,
2016

2. A.: Correct in code designation, "This specification meets the requirements of ASTM E165/E165M-12,"Standard Recommended Practice for Liquid Penetrant Inspection Methods."

2. B.: inserted new, "This standard is used for the preparation of process specifications and procedures dealing with the liquid penetrant testing of parts and materials."

3. Inspection Personnel, revised to include certified,

"All personnel conducting liquid penetrant testing shall be qualified and certified in accordance with the requirements of ASNT SNT-TC-1A - Level III for Penetrant Testing, Latest Edition accepted by PHMSA."

5. Inspection Procedures

5. D. Penetrant Application

5. D. (1): Expanded to allow brushing, blotting, or immersion for applying penetrant.

(1) "With the pipe and penetrant temperature between 60 degrees F. and 125 degrees F. and the surface cleaned, the penetrant shall be applied to the area to be inspected using aerosol spray cans, spraying, brushing, blotting or immersion and applied in such manner as to provide complete coverage over the area being tested."

5. E. Penetrant Removal

5. E. (1): Added the word "excess" and method for removal, After the desired dwell (soak) time has elapsed, the excess penetrant shall be removed in the following manner:

(a) "First use a clean lint free rag or towel to wipe the area.

(b) Once this is completed, use a clean lint free cloth or towel lightly moistened with solvent to remove the remaining traces of surface penetrant."

5. F. Developer Application

5. F. (1): Added the word "wet" and stipulation that the wet developer be non-aqueous.

"Once all visible penetrant has been removed, and the weld surface is dry (by normal evaporation), the wet developer shall be sprayed directly on the weld and adjacent area. The wet developer should be a non-aqueous developer."

5. F. (3): Increased the time the developer is to remain on area to 10 minutes from 7 minutes.

(3) "The wet developer shall remain on the area for a minimum time of ten (10) minutes prior to inspection."

5. F. (4): Added new:

(4) "The development time does not start until the developer has completely dried."

5. G. Inspection

5. G. (1): Added the required illumination,

(1) With proper illumination, minimum light intensity of 100 foot candles, inspect the developer for bleed-out of penetrant from discontinuities.

5. H. Acceptance Criteria

5. H. (1): Revised to;

(1) "The standard of acceptability shall be API 1104, Acceptance Standards for Nondestructive Testing, Latest Edition accepted by PHMSA, except that cracks of any length are not allowed. Acceptance criterion will include porosity charts directly from API 1104, 20th edition shown below."

5. H. (2): Added, "Maximum Distribution of Gas Pockets: Wall Thickness Less Than or Equal to 0.500 in.(API 1104)"

5. H. (3): Added, "Maximum Distribution of Gas Pockets: Wall Thicknesses Greater than 0.500 in (API1104)"

6. Inspection Equipment

6. C.: New item specifies the code which the liquid penetrant must comply.

C. "Liquid penetrant material utilized shall meet the requirements of AMS2644 and intermixing of penetrants from different manufacturers is prohibited."

7. Reports

7. A.: Significantly expanded to include a list of 12 items that should be included in the report. List is too long to show here.

**WELD
2.10**

Arc Burn Removal

January 1, 2012 January 1, 2016

1. General

1. C.: Revised to: "For these reasons arc burns shall be removed on transmission pipeline and should be removed on high pressure distribution pipeline or at the welding inspector's option cut out."

Allows for arc burns to be removed in accordance with the procedures. Removal is required on transmission pipe and should be done on high pressure distribution pipe.

1. B.: New, "A welder who repeatedly makes arc burns may be subject to disqualification or other disciplinary action."

Former 1. B and 1. C. has been removed.

2. Removal Sequence

2. A. (6): Revised to "Upon removal of all evidence, swab the ground area using "a" tip or cotton ball with an appropriate

American Welding Society (AWS) approved etching solution such as a 20 percent solution of ammonium persulfate (20% ammonium persulfate crystals and 80% water). If a blackened spot appears, the metallurgical notch (arc burn) has not been completely removed and additional grinding/filing should be performed and the application the approved etching solution repeated."

Expanded to include reference to AWS approved etching solution. There may be other approved etching solutions available than the 20% solution of ammonium persulfate.

2. A. (8): Revised to "If the resulting wall thickness is less than required, the portion of the pipe that contained the arc burn should be removed as a cylinder or repaired with an approved procedure listed in REPR 1."

Added or repair with an approved procedure.

WELD 3.01	<p>Post-Weld Heat Treatment</p> <p>Removed this section from the O&M. Ameren Illinois does not utilize this process and it is not contained in Part 192 code.</p>	January 1, 2012	
WELD 3.02	<p>Useful Information</p> <p>3. Pipe Properties</p> <p>Former 3.B. Tolerances for Wall Thickness, Table 9: for pipe manufactured before 2009 and Table 11 for pipe manufactured in 2009 and after were removed.</p> <p>Those tables are in WELD 2.10 Arc Burn Removal. Throughout WELD and REPR sections these tables are reference as being in WELD 2.10.</p>	January 1, 2012	January 1, 2016
WELD 4	<p>Forms and Reference Materials</p> <p>Reference Materials:</p> <p>All 51 welding procedures have been updated so that only the actual welding procedure, WPS, is in this section. There are 4 new SMAW fixed position procedures; 2 new GMAW fixed position procedures, 2 new SMAW rolled position procedures and 1 new GMAW rolled position procedure.</p> <p>The WPQRs' for each WPS has been separated out and will be kept by the Gas Training section.</p>	January 1, 2013	January 1, 2016
WW- BG 0	<p>Table of Contents</p> <p>2.01 3. Changed for Safe Zone from Secure Area</p> <p>2.02 2. Changed to Specialized Tools and Equipment Share-Point Site</p> <p>2.02 3: New; Personal Protective Equipment (PPE) Acquisition</p> <p>2.02 4: Changed to Level 1 PPE Availability, Care and Storage</p>	January 1, 2011	January 1, 2016

2.02 5. Changed to Level 2 PPE Availability, Care and Storage

2.02 6. New, Inspection

WW- BG 1	<p>Requirements</p> <p>2. Definitions</p> <p>Deleted definition of blowing gas</p> <p>2. D. Level 2 PPE - removed "in addition to Level 1 PPE". Level 2 PPE is specified in WWBG 2.02</p>	<p>October 1, 2011</p>	<p>January 1, 2016</p>
WW- BG 2.01	<p>Hazardous Atmosphere</p> <p>2. Identifying a Hazardous Outdoor Atmosphere</p> <p>2. B. (1): Added "without an EFV" to service line.</p> <p>2. B. (2): Added "with blowing gas" to damage to regulator station, farm tap, meter set, riser, or other gas facility.</p> <p>3. Secure Area</p> <p>3. A. (1): Added reference to EMER 2.03 Emergency Responder for non-gas field personnel that are dispatched to make area safe until qualified personnel arrive.</p> <p>3. B.: New item 'Responding to a Small Diameter Cut PE Service (1/2" thru 1-1/4")</p> <p>(1) "Gas field personnel wearing Level 1 PPE may approach a small diameter, 1-1/4 inch or less, cut PE service line to control the flow of gas utilizing the following procedures:</p> <p>(a) Approach from an upwind position</p> <p>(b) Monitor the gas concentration and maintain a level of less than 30% LEL</p> <p>(c) Squeeze off the service line with an above grade squeeze tool or from an above grade position with only an arm extended into the excavation. The head must remain out of the excavation"</p> <p>This was added to allow responding gas field personnel to squeeze of PE service lines without establishing a safe zone.</p> <p>3. C.: Changed heading to "Establishing a Safe Zone</p> <p>3. C. (1): Revised to "After the extent of the gas migration is determined or additional gas personnel have arrived to assist, a safe zone will be established if the blowing gas is the result of damaged gas facilities other than a small diameter PE service line."</p> <p>Revision made to emphasize the importance of first determining the extent of the migration of gas when responding to a blowing gas call.</p> <p>3. C. (4): Grammatical addition of "outside of the safe zone", "As long as there is blowing gas, gas field personnel will moni-</p>	<p>October 1, 2011</p>	<p>January 1, 2016</p>

tor the perimeter of the safe zone to ensure the atmosphere outside the safe zone remains non-hazardous."

3. C. (5): Revised to "If the area is readily accessible to the general public the perimeter of the Safe Zone should be visually marked by such means as barricade(s), sign(s), cone(s), fencing, marking paint or tape."

Revised to clarify that a safe zone only needs to be marked if it is readily accessible to the general public. When the blowing gas is in a remote or rural area where the general public is not present, marking of the safe zone is not necessary since only gas personnel or emergency responders should be present.

3. C. (8): Added "should be visually marked" when referring to the perimeter of a hazardous area with gas concentration of 60% LEL or greater where Level 2 PPE is required.

4. Working in a Hazardous Outdoor Atmosphere

4. C.: New inserted "If working in an excavation is required, the procedure in EXCV 2.09 - Working in Hazardous Atmosphere should be reviewed and utilized in conjunction with these procedures."

4. F. (2): Grammatical "less than 30% LEL" replaces "up to 30% LEL".

4. F. (3): Grammatical only "Be suited up in Level 1 PPE if a CGI reading of 30% LEL (1.5% gas-in-air) to 60 % LEL (3.0% gas-in-air) is measured in the atmosphere where the work is to be performed."

4. F. (4): Grammatical only "Be suited up in Level 2 PPE if a CGI reading of 60% LEL (3.0% gas-in-air) or greater is measured in the atmosphere where the work is to be performed."

4. F. (5): New inserted: "Have a dry chemical (A, B, C) fire extinguisher present near the worksite at all times while work is being performed in a gaseous atmosphere."

4. F. (6) (a): Added that the Manned fire extinguisher should be a minimum of 20 pound and shall be discharged tested prior to work being performed.

6. PPE Requirements

6. A.: Grammatical only by adding "Level 1 is designed to provide protection against a flash fire."

6. B.: Grammatical only by adding "Level 2 is designed to provide protection against a sustained fire."

**WW-
BG
2.02**

Personal Protective Equipment

1. B.: New: "Ameren Illinois continues to evaluate PPE products. Once a product is approved by the Gas Standards and Procedures group in conjunction with Ameren Illinois Safety Department, the product will be added to the Specialized Tools and Equipment on the Gas Operations and Services Share-

October 1,
2011

January 1,
2016

Point Site. Therefore, not all approved PPE items may not be contained in this edition of the Gas O&M."

1. E.: New, added a table that lists the PPE required for Level 1 and Level 2 and shows the ensembles for Level 2 with the Bulwark Insulated Coveralls and Silver Needle Insulated Coveralls.

2. Renamed "Specialized Tools and Equipment SharePoint Site"

Removed the vendor information since it will be on the Specialized Tools and Equipment SharePoint Site in the future.

This section was revised to list only the basic specifications or requirements for the various items of PPE.

3. Personal Protective Equipment (PPE) Acquisition - This was put in its own section and the procedures were updated to reference the SharePoint site.

4. Renamed "Level 1 PPE Availability, Care and Storage" from "Level 1 PPE". Information is basically the same.

5. Renamed "Level 2 PPE Availability, Care and Storage" from "Level 2 PPE". Information is basically the same.

6. Inspection

6. A.: Revise to list equipment that is included in the monthly inspection, supplied air equipment including air supply, filtration system, carbon monoxide alarm, regulator/manifold system, hoses, and airline units. The inspections are document in Maximo.

6. B.: New, "Escape bottles must be inspected annually and hydrostatically tested every 5 years by a qualified person.

Supersedes: December 1, 2014

CHANGE SUMMARY

December 1, 2014

Change Summary December 1, 2014

Docu- ment	Change Summary	Previ- ous Docu- ment Dated	Current Docu- ment Dated
	<p>The main focus of the following O&M changes is to reflect the implementation of the new gas code compliance systems; Maximo, ClickSchedule, and ClickMobile. References to Gas Compliance System (GCS) has been replaced with one or more of these new systems throughout the O&M.</p>		
ABND 1	<p>3. Records</p> <p>3. B.: Information on abandoned facilities will now be maintained in Maximo. The information will be entered in ClickMobile then uploaded to Maximo.</p> <p>There will no longer be a paper record for abandoned facilities that has to be filed.</p>	Janu- ary 1, 2014	De- cem- ber 1, 2014
ABND 2.01	<p>Abandonment of Gas Facilities</p> <p>5. Records</p> <p>5. B. (2): "In ClickMobile the service record should indicate a full retirement, but the stub greater than 18 inches box should be checked."</p> <p>5. C.: "Service record card (Service Transaction Form/Card) should be updated within ClickMobile to document the retirement and leak test performed to check the capping of the pressurized stub."</p> <p>5. D.: "Buried Pipe Examination Form should be completed within ClickMobile to report condition of the remaining pressurized main(s) and/or service line(s). See CORR 2.30"</p> <p>5. E.: "If there is evidence for internal corrosion it shall be documented on the Corrosion and Steel Damage Evaluation form within ClickMobile. See CORR 2.31"</p> <p>All abandonment records will now be electronic and entered within ClickMobile.</p>	Janu- ary 1, 2014	De- cem- ber 1, 2014
CNTS 1	<p>4. Reporting of Gas Leaks</p> <p>4. A.: Added the Ameren Emergency phone number, 1.800.755.5000. Non-gas field personnel who detect an odor of gas should call the Emergency phone number to report the odor.</p> <p>Instead of Non-gas field representative attempting to contact the Gas Supervisor, SMR Team felt it would be best and quicker to call of the Contact Center to report a leak.</p>	Janu- ary 1, 2012	De- cem- ber 1, 2014

7. System Review Report

7. D.: Updated the title of the individual to whom the System Review Report is to be sent, Manager, Gas Compliance & Training, PWN-427 (MC for Pawnee Gas Training Center)

CNTS 2.01	<p>Surface Subsidence Areas</p> <p>3. Active Surface Subsidence Area</p> <p>3. C.: "A special leak survey shall be set up for subsidence area within Maximo. Contact Compliance Specialist for assistance in setting up the survey in Maximo."</p> <p>3. D.: All leak survey activity will be completed within ClickMobile and recorded in Maximo.</p> <p>3. E.: "After two (2) years without any further indication of new subsidence in the affected area a final leak survey can be conducted and the special leak survey retired in Maximo."</p> <p>7. Records</p> <p>7. A.: "Gas Supervisor should ensure that activities, leak surveys, patrol, repairs, temporary provisions made or taken are documented in ClickMobile." 7. C.: "Written report(s) describing activities performed, dates performed, employees performing activities, findings, and corrective action taken should be retained by the Gas Supervisor, Gas Superintendent, or the Engineer/Supervisor of the group overseeing the activities."</p> <p>Expanded to specify the Gas Supervisor, Gas Supt, or Engineer/Supervisor of group overseeing the activities should retain the written reports.</p>	Janu- ary 1, 2014	De- cem- ber 1, 2014
<u>CONS</u> <u>1</u>	<p>2. Construction Records, Maps, and Operating History</p> <p>2. B.: Replaced "Ameren Illinois gas compliance system" with "Maximo" as the location where much of the operating history is maintained.</p>	July 1, 2014	De- cem- ber 1, 2014
CORR 0	<p>CORR 2.30 - Pipe Examination Form</p> <p>Deleted:</p> <p>Stock Number for Form</p> <p>Flowchart Buried Pipe Examination Form</p> <p>CORR 2.31 - Corrosion and Steel Damage Evaluation Form</p> <p>Deleted:</p> <p>Stock Number for Form</p> <p>Flowchart Buried Pipe Examination Corrosion and Steel Damage Evaluation</p> <p>CORR 4 Forms and Reference Materials</p>	July 1, 2014	De- cem- ber 1, 2014

Deleted Forms:

Buried Pipe Examination Form

Corrosion and Steel Damage Evaluation Form

Deleted Reference Material:

Corrosion Tracking in DOJM and GCS

CORR
1

3. Corrective Action

3. C. (2)(a): Replaced "GCS" with "Maximo". When P/S readings on an unmonitored pipe is less negative than -0.900 volts, an integrity leak survey shall be created in Maximo.

July 1, 2014
December 1, 2014

6. External Corrosion

6. A.: Revised to: "When any portion of a buried steel main or service is exposed, an examination of the exposed portion must be conducted and recorded on the Buried Pipe Examination form within ClickMobile with the information retained in Maximo."

Deleted 6. A. Note and the 3 bullet points that address entry in Pipe Exam Database and distribution of the Buried Pipe Examination Form.

Information no longer valid since the form is being completed and maintained electronically.

6. B.: Revised to: "Reports from Maximo are sent to Corrosion Control personnel listing the locations where pipe to soil readings were -0.900 volts or less. Corrosion Control personnel will then perform follow-up investigation. The required corrective measures will be identified, performed and entered in ClickMobile or scheduled."

Deleted reference to Pipe Exam Database, PEET. This database will no longer be utilized since all records will now be maintained in Maximo.

7. Internal Corrosion

7. A.: Added ClickMobile - "All tapping coupons are to be inspected for evidence of internal corrosion and documented on the Buried Pipe Examination form within ClickMobile. See CORR 2.30."

7. D.: Added ClickMobile - "Corrosion Control person or qualified Gas Engineer will complete a Corrosion and Steel Damage Evaluation form within ClickMobile, CORR 2.31"

10. Test Lead Connections;

10. A.: Added a second reference CORR 3.13 as another method for attaching test leads to pipe. 13. Atmospheric Corrosion

13. C. (2): Corrective action or disbonded coating reported during compliance inspection shall be tracked in Maximo.

13. E. (3): Revised to indicate the Corrosion and Steel Damage Evaluation form is completed within ClickMobile.

14. Pipeline Facilities That Need to Be Painted

14. B. (1): Revised to: "Maximo will maintain a list of facilities that need paint and will track corrective action by specific address or location. Gas Supervisors can continue to use spreadsheets that list locations where deficiencies were discovered prior to December 1, 2014."

14. B. (2): Second sentence revised to: "Whenever gas field personnel are on site for other activities and identify disbonded coating, atmospheric corrosion, or pipeline facilities that need to be painted, corrective action shall be taken while on site or documented within ClickMobile."

16. Records

16. C.: "All information shall be maintained in Maximo and the electronic mapping system." Maximo replaces Gas Compliance System.

CORR 2.02	<p>Anode Requirements</p> <p>The July 1, 2014 Web and Local Viewer version of CORR 2.02 did not include one of the revised instructions that had been made in one of the tables, 4. B. The published July 1, 2014 version did include the correct instructions.</p> <p>4. Anode Requirements</p> <p>4. B.: Service lines and repairs steel main and services, install anodes as shown in table.</p> <p>Revised the instructions if the P/S reading is less negative than -0.900 VDC. Install an anode as long as it is not a transmission main.</p> <p>Corrosion Control SMR team felt the logical course of action would be to install an anode rather than contacting a corrosion control person, who in most cases advise installing an anode when it is not a transmission main. Example of a more negative and a less negative reading was added to provide clarification and eliminate confusion.</p>	October 1, 2011	July 1, 2014
CORR 2.28	<p>Evaluation of Corrosion</p> <p>2. Distribution Piping (60 psig and Below)</p> <p>2. B. Measuring Pitted Areas (Underground or Atmospheric Corrosion)</p> <p>2. B. (6): Revised to: "Document on the Corrosion and Steel Damage Evaluation form within ClickMobile."</p> <p>3. Transmission or High Pressure Distribution Piping (Over 60 psig)</p>	April 1, 2013	December 1, 2014

3. B. Measuring Pitted Areas (Underground or Atmospheric Corrosion)

3. B. (6): Revised to: Document on the Corrosion and Steel Damage Evaluation form within ClickMobile."

6. Pipe Pit Gauge

6. B. Instructions

6. B. (7): Record data on Corrosion and Steel Damage Evaluation form within ClickMobile.

7. Pipe Thickness Gauge

7. B. Instructions

7. B. (6): Record data on Corrosion and Steel Damage Evaluation form within ClickMobile.

CORR
2.29

Records

1. C.: Deleted instructions for tracking corrective action utilizing the Gas Compliance System's Cathodic Protection Module that was in CORR 4 Reference Materials.

Maximo will track corrective action so there is no need to provide instructions.

2. Construction Order Review Processes

2. B. Belleville Design Center/Peoria Design Center

2. B. (1) (c): Updated the Corrosion Techs in the table showing areas of responsibility.

3. Additional Detail Information for Test Points

3. A.: Revised to: "Each test point detail sketch may be attached to the asset in Maximo."

3. B. Pipeline Crossing Sketches: On the form "Readings recorded in ClickMobile" Replaced GCS.

4. Other Cathodic Protection Record Activities

4. A. Pipe Exam Review Process 4. A. (1): Revised to: "Transmission, high pressure distribution and distribution pipe Buried Pipe Examinations are completed within ClickMobile and stored in Maximo. See CORR 2.30"

Buried Pipe Examination is required for all classes of pipe and sending copies to other groups is no longer needed since the Examination is now completed in ClickMobile and information is maintained in Maximo. Maximo will send out messages when corrective action is needed.

4. A. (4): Deleted reference to CP Deficiency Tracking in Cathodic Protection Sharepoint site.

Replaced with: "Corrective orders for deficient pipe-to-soil potentials not related to annual test points can be tracked in Maximo." 4. B. Annual Tasks

July 1, 2014
December 1, 2014

4. B. (2)(i): Revised to: " As needed, review casing drawings or permits for casing details to be added as test point detail sketches in Maximo."

CORR
2.30

Buried Pipe Examination

July 1,
2014 De-
cem-
ber 1,
2014

The Buried Pipe Examination will now be entered within Click-Mobile and the paper form is being eliminated.

2. Buried Pipe Examination

2. A.: Revised to "The Buried Pipe Examination shall be completed by gas field personnel or Damage Prevention's Watch and Protect personnel, construction inspectors, engineering personnel, or others any time existing buried plastic or steel gas carrying pipe is exposed. An examination of the exposed portion must be conducted and recorded on the Buried Pipe Examination form within ClickMobile."

2. B.: Revised to "A Buried Pipe Examination form shall be completed within ClickMobile any time existing main or service pipe, plastic or steel, is exposed and the existing pipe is planned to remain in service."

2. C.: Revised to "A Buried Pipe Examination form is required for each pipe segment and should be completed on ClickMobile."

Removed the ability to report the condition of all pipe exposed in one excavation.

2. D.: Revised to "If the examination of the pipe indicates the presence of corrosion or damage to the pipe then a Corrosion and Steel Damage Form should be completed within ClickMobile. See CORR 2.31."

2. E.: Revised to "A Buried Pipe Examination form is not required when:"

2. E. (1) "New pipe being installed."

2. E. (2) "When an existing section of pipe is planned to be retired and will not remain in service."

2. E. (3) "The exposed pipe is found during a pipeline or critical area patrol."

2. E. (4) "When pipe is not going to be buried"

This was revised to better clarify when a Buried Pipe Examination is not required.

2. G.: Revised to "The internal surface of the abandoned pipe must be inspected for evidence of corrosion as stated in CORR 1. A corrosion control person for the area should be notified if there is an indication of internal corrosion. Any internal corrosion found will be documented on a Corrosion and Steel Damage Evaluation within ClickMobile, CORR 2.31, stating where the internal corrosion was found; on the pipe remaining in service or the abandoned pipe."

UNCONTROLLED IF PRINTED

2. H.: Revised to "Information from Buried Pipe Examination forms is maintained in Maximo."

PEET database has been eliminated.

2. I.: Revised to "Information will be used by Corrosion, Operations, Engineering, Corrosion Control, DIMP, and TIMP personnel for evaluation, maintenance and risk analysis."

Former 2. D.: Deleted the requirement for a Buried Pipe Examination for each excavation. Now a separate examination form must be completed for each pipe segment.

3. Distribution

3. A.: Revised to "Buried Pipe Examination will be completed within ClickMobile. The information will be transferred and maintained in Maximo."

3. B.: Revised to "Maximo will generate a Task and send it to Corrosion Control, Gas Tech Engineering or the Pipeline Integrity Group. When corrective action is required. Maximo will track and maintain corrective action taken."

Since the examination form is being completed electronically in ClickMobile and the data is uploaded into Maximo, there is no need to physically distribute information to other groups.

4. Completion Instructions

4. A.: New "The Buried Pipe Examination Form will be completed within ClickMobile."

4. B.: New "The required information field are indicated in Red. However, it is good practice to record all information that is known"

4. C.: New "It is important that accurate pipe information be entered in ClickMobile."

Removed the instructions on completing the paper form since the information will now be enter on the form in ClickMobile. Deleted copy of the examination form.

Former 6 Flowchart of processing the Buried Pipe Examination Form has been removed since much of it is no longer applicable with implementation of Maximo and ClickMobile.

Former 4. Stock Number for Form has been removed since the form is no longer going to be used.

5. Records

5. A.: New "Information from Buried Pipe Examination forms is maintained in Maximo."

5. B.: New "Maximo tracks and maintains corrective action taken and reported within ClickMobile."

5. C.: New "Tasks and queries can be generated and submitted to the appropriate work groups."

Records will be maintained electronically in Maximo so there will no longer be physical records to file or maintain.

CORR
2.31

Corrosion and Steel Damage Evaluation

April
1,
2013

De-
cem-
ber 1,
2014

The Corrosion and Steel Damage Evaluation will now be entered within ClickMobile and the paper form is being eliminated.

2. Distribution

2. A.: Revised to "Corrosion and Steel Damage Evaluation form will be completed within ClickMobile. The information will be transferred and maintained in Maximo."

2. B.: Revised to "Maximo will generate a Task and send it to Corrosion Control when corrective action is required. Maximo will track and maintain corrective action taken."

Since the evaluation form is being completed electronically in ClickMobile and the data is uploaded into Maximo, there is no need to physically distribute information to other groups. Maximo will create corrective action orders when needed and send them to the appropriate parties.

3. Completion Instructions

3. A.: New "The Corrosion and Steel Damage Evaluation Form will be completed within ClickMobile."

3. B.: New "The required information field are indicated in Red. However, it is good practice to record all information that is known"

3. C.: New "It is important that accurate pipe information be entered in ClickMobile."

4. Records

4. A.: New "Information from Corrosion and Steel Damage Evaluation forms is maintained in Maximo."

4. B.: New "Maximo tracks and maintains corrective action taken and reported within ClickMobile."

4. C.: New "Tasks and queries can be generated and submitted to the appropriate work groups."

Records will be maintained electronically in Maximo so there will no longer be physical records to file or maintain.

Former 3. Stock Number for Form has been removed since the form is no longer going to be used.

Former 4 Removed the instructions on completing the paper form since the information will now be enter on the form in ClickMobile. Deleted copy of the evaluation form.

Former 5 Flowchart Buried Pipe Examination - Corrosion and Steel Damage Evaluation has been removed since much of it is no longer applicable with implementation of Maximo and Click-Mobile.

CORR 4	<p>Forms and Reference Materials</p> <p>Updated Pipeline Crossing Sketch - Changed GCS to ClickMobile Deleted Forms:</p> <p>Buried Pipe Examination Form</p> <p>Corrosion and Steel Damage Evaluation Form</p> <p>Deleted Reference Material: Corrosion Tracking in DOJM and GCS</p>	Janu- ary 1, 2013	De- cem- ber 1, 2014
<u>DAMG</u> 1	<p>4. JULIE Ticket Transmittal</p> <p>4. A. Locate Request Tickets</p> <p>4. A. (6): Added "Gas field personnel can put dimensions on their ClickMobile maps, take a screenshot, attach it to a GIS discrepancy, and incomplete it within ClickMobile. This will get sent to the DDC so the measurements may be mapped. The can also put the measurements in the comment section of the service card."</p> <p>Provides instructions on how field personnel can make sketch in ClickMobile with measurements when they are standing by on difficult to locate gas facilities.</p> <p>7. Protection of Excavated Facilities</p> <p>7. A. (1): Replaced the 2" and 4" Safety Wraps with one Safety Wrap that covers both 2" and 4" diameter pipe.</p> <p>Manufacturer combined the two separate wraps into one.</p> <p>8. Excavating Near a Transmission, High Pressure Distribution, or 8" and Larger Steel Main</p> <p>8. E. (1): Revised to indicate the Buried Pipe Examination is completed within ClickMobile.</p> <p>8. F.: Revised to indicate the Buried Pipe Examination is completed within ClickMobile.</p> <p>12. Records</p> <p>12. D.: Added "Buried Pipe Examination forms completed prior to November 1 2014 shall be retained for the life of the facility. Beginning November 1, 2014 information shall be maintained in Maximo for the life of the facility."</p>	Janu- ary 1, 2014	De- cem- ber 1, 2014
FORW	<p>Forward</p> <p>5. Contacts</p> <p>Replaced Gas Compliance System (GCS) with Maximo, Click-Mobile, ClickSchedule</p>	Janu- ary 1, 2014	De- cem- ber 1, 2014
<u>GLOS</u>	<p>Glossary</p> <p>Modified: Gas Compliance System (GCS) - Company system utilized to manage and document various gas operating and</p>	Janu- ary 1, 2014	De- cem-

maintenance activities. Beginning December 1, 2014, GCS was replaced with a suite of compliance products; Maximo, ClickMobile, and ClickSchedule

ber 1,
2014

Added New Definitions:

ClickMobile - Mobile Workforce Management system used to document Gas Compliance activities electronically.

ClickSchedule - Mobile Workforce Management system used to schedule and dispatch Gas Compliance activities to field technicians

Maximo - Asset Management System utilized for Gas Compliance activities

Natural Gas Reading - A reading of 2.0% LEL or less is considered 0% gas for leak classification/documentation purposes and is not a reportable reading if the reading is greater than five (5) feet from a foundation wall.

LEAK
0

LEAK 2.04 Leak Classification and Surveillance

Janu-
ary 1,
2014

De-
cem-
ber 1,
2014

Deleted the following:

Venting a Leak

Downgrading a Leak

Ameren Illinois Leak Classification Guidelines

LEAK 2.05 Gas Leak Case Field Report

Removed the instructions for completing the GLCFR and Mechanical Fitting Leak form since they are now completed in ClickMobile.

LEAK 4 Forms

Removed:

GCS Leak Case Field Report

Leak Survey Daily Report Form

Mechanical Fitting Leak Data Form

LEAK
2.02

Outdoor Leak Investigation

Janu-
ary 1,
2013

De-
cem-
ber 1,
2014

5. Below Grade Gas Facilities

5. I. (2): Revised to "Bar hole locations and % Gas readings taken with a CGI should be recorded on the leak sketch within ClickMobile"

7. Hazardous Condition

7. A. (2): Changed to: "A reading in a sanitary sewer of 30% LEL (1.5% gas-in-air) or greater."

Significant reduction from the previous 80% LEL reading. This was changed to be consistent with other sections in the O&M

where hazardous condition exists when the reading is 30% LEL or greater.

7. B.: Eliminated reclassifying a hazardous leak to a Class 2. This now reads "Gas field personnel shall remain at the site of a hazardous leak until the leak is repaired. A safety perimeter should be established to prevent unauthorized personnel from entering until repairs are made or the situation made safe."

Reclassifying a Class 1 leak to a Class 2 leak by venting the leak has been eliminated as an option under the new gas compliance system.

8. Leaks on Customer Owned Facilities

8. B.: Removed "soap bubble holds" as an example of a non-hazardous leak on customer facilities.

Soap bubble holds is no longer used in the new compliance system.

9. Records

9. C.: Revised to "If the leak is discovered on Ameren Illinois facilities, leak investigation shall be initiated within ClickMobile."

All leaks found on Ameren facilities will be reported in ClickMobile by initiating a leak investigation task. Even if leak is repaired when found, it still requires entry in ClickMobile along with the repair information.

9. D.: New "If an existing leak exists at the address/location, a leak surveillance shall be performed and documented within ClickMobile."

Existing leaks will show on the ClickMobile Map, so instead of creating a new leak, a surveillance will be performed and documented in ClickMobile.

9. D. thru F.: Deleted the instructions on how and when to report: Class 1 Above Grade leaks, Class 3 Above Grade leaks found during compliance inspections, and Above & Below Grade leaks found during compliance inspections.

No longer valid since all leaks and their status will now be documented within ClickMobile and maintained in Maximo.

LEAK
2.03

Leak Investigation Form

2. Top Block - General Information

2. A. (7): GCS No. - Deleted - No longer applicable

2. A. (8): Deleted the instructions for recording OAS number on GLCFR since that form has been eliminated.

4. Outdoor Investigation Documentation

4. A. Check Outside Area

April	De-
1,	cem-
2013	ber 1,
	2014

4. A. (11)(b): Revised to require documenting findings on the OAS 6F screen and completing the leak and surveillance information within ClickMobile.

4. B. Perform Subsurface Sampling - Utilizing a CGI & Probe Rod

4. B. (2)(d): Revised to require documenting the leak and surveillance information within ClickMobile.

4. C. Bar Test Riser

4. C. (3)(c): Revised to require documenting the leak and surveillance information within ClickMobile which replaces the Gas Leak Case Field Report.

5. Back Page Information

5. C. Follow-up Action - In this area

5. C. (3)(c): Revised to "Leak repair order will be available for completion by crew in ClickMobile." Eliminated the need to provide Gas Supervisor with copy of GLCFR.

6. Records

All leak records are now documented in ClickMobile and maintained in Maximo.

6. B.: Deleted Refer to LEAK 2.05 since the Gas Leak Case Field Report has been eliminated.

All references to Gas Leak Case Field Report have been removed since that form is no longer utilized in the new compliance system.

LEAK
2.04

Leak Classification and Surveillance

2. Leak Classification

2. C.: Added reference to LEAK 2.06 which has the flow charts for the leak classification process for both below grade and above grade gas leaks

2. F.: Added reference to LEAK 2.06 which has the flow chart for the process to classify an above grade gas leak.

4. Leak Classification Criteria

4. E.: Deleted reference to Ameren Illinois Gas Leak Classification Guideline card since the card has been eliminated. Click-Mobile will classify leaks based on information provided.

4. F.: New: "LEAK 2.06 provides qualified gas field personnel with criteria utilized for accurate classification of both below grade and above grade gas leaks."

8. Leak Surveillance, Repair, and Recheck Schedule

8. A. Class 1

January 1,
2014

December 1,
2014

8. A. (1): Revised to: "Class 1 leak requires immediate repair or continuous action until the hazardous condition no longer exists. Immediate temporary measures, such as venting, may be employed to protect the public and property, however, the leak remains a Class 1 leak until permanent repairs are made."

Although venting as a means for downgrading a Class 1 leak to a Class 2 leak has been eliminated, venting can be used as a temporary measure but the leak will remain a Class 1 leak and will require continuous monitoring until it is repaired.

8. B. Class 2

8. B. (1) Surveillance

8. B. (1) Removed the exception to the surveillance interval when a Class 1 leak has been downgraded to Class 2 by venting when gas was initially detected entering a building. Venting is no longer an option for downgrading.

8. B. (2) Repair

8. B. (2): Removed the exception to the repair interval when a Class 1 leak has been downgraded to Class 2 by venting when gas was initially detected entering a building. Venting is no longer an option for downgrading.

10. Repaired Leak Recheck

10. A. Below Grade

10 A. (3) Where residual gas is detected in the soil,

10. A. (3)(a): Changed to "The presence of residual gas shall be documented on the ClickMobile Repair Form."

10. A. (3)(b): Changed to "If the residual gas readings are detected within zero (0) to five (5) feet from the foundation wall, daily monitor tasks will also have to be performed."

10. A. (4): New - "Leak recheck must be performed within thirty (30) days of repair. If natural gas readings are detected during the recheck, the leak recheck should be completed noting the readings and classifying the leak accordingly."

11. Records 11. D.: Revised to "Leak investigation, repair, monitor, and recheck information shall be recorded in ClickMobile. Records pertaining to leak classification and leak surveillance shall be maintained for six (6) years." 11. F.: Revised to "The information and associated sketches shall be recorded within ClickMobile and retained within Maximo"

Former 7. Venting a Leak - This section has been deleted since venting a leak is no longer an option for reclassifying a Class 1 leak to a Class 2.

Former 8. Downgrading a Leak - This section had been deleted because ClickMobile will classify the leak.

Former 10.: Deleted the Ameren Illinois Leak Classification Guidelines

Former 13. A. (3): Removed "This recheck may be performed immediately after repair of a gas leak, where no residual gas is detected in the soil." since all below grade repaired leaks require a recheck with a CGI.

LEAK 2.05	<p>Gas Leak Case Field Report</p> <p>Gas Leak Case Field Report has been eliminated. Leak investigation information is now documented in ClickMobile and maintained in Maximo.</p> <p>The Mechanical Fitting Leak Data Form is now completed within ClickMobile and the use of the paper form has been discontinued.</p>	January 1, 2014	December 1, 2014
LEAK 2.06	<p>Leak Process Flow Charts</p> <p>Flow charts were revised to show the leak classification process based the gas field personnel's responses to leak investigation questions within ClickMobile.</p>	January 1, 2013	December 1, 2014
LEAK 2.07	<p>Leak Surveys</p> <p>2. Leak Survey Types</p> <p>2. A. Transmission Mains</p> <p>2. A. (5)(c): Added a note "Ameren Illinois does not have facilities in Class 4 areas."</p> <p>2. A. (6)(b): Clarified if gas meter with an underground fuel line is more than three (3) feet from the residential structure surveyor will notify Gas Supervisor. Supervisor will add the location to appropriate yardline survey.</p> <p>Added with underground fuel line to clarify yardline survey applies only to buried lines.</p> <p>2. A. (9)(f) & (g): Added See METR 2.20 for pictures of banded regulators and substandard regulators</p> <p>2. A.(10): Revised to "If any of the above deficiencies are noted, they will be repaired immediately or reported within Click-Mobile for follow-up action."</p> <p>Eliminated notifying Gas Supervisor since Maximo will schedule and track follow-up action.</p> <p>2. B. Distribution and High Pressure Distribution Mains and Services</p> <p>2. B.(4): Clarified if gas meter with an underground fuel line is more than three (3) feet from the residential structure surveyor will notify Gas Supervisor. Supervisor will add the location to appropriate yardline survey.</p> <p>Added with underground fuel line to clarify yardline survey applies only to buried lines.</p>	April 1, 2012	December 1, 2014

2. B. (7)(f) & (g): Added See METR 2.20 for pictures of banded regulators and substandard regulators

2. B. (8): Revised to "If any of the above deficiencies are noted, they will be repaired immediately or reported within ClickMobile for follow-up action."

Eliminated notifying Gas Supervisor since Maximo will schedule and track follow-up action.

2. C.: Business Districts

2. C. (7): New "Division engineering and gas supervision should review Business District area periodically not to exceed five (5) years commencing in 2015."

SMR team felt that the Business District areas should be periodically reviewed by Division engineer and gas supervision to ensure the correct areas are being leak surveyed. The O&M is currently silent on this issue.

2. C. (13)(h) & (i): Added See METR 2.20 for pictures of banded regulators and substandard regulators

2. C. (14): Revised to "If any of the above deficiencies are noted, they will be repaired immediately or reported within ClickMobile for follow-up action."

Eliminated notifying Gas Supervisor since Maximo will schedule and track follow-up action.

2. D. Yardlines

2. D. (3): Revised to "Gas Supervisor will maintain list of all residential yardlines in Maximo."

2. D. (8) Leak found on yardlines must be made safe.

2. D. (8)(a): Revised to "A contract surveyor will call the Ameren Illinois emergency phone number 1.800.755.5000 to report the leak. Ameren Illinois gas field personnel will contact the Gas Supervisor or an Ameren Illinois' designee."

2. D. (8)(b): Revised to "An OAS EMGL will be created and a qualified gas field person dispatched to respond to the leak." Removed Gas Supervisor as the one to create the order since this can be done by different individuals.

2. E. inside Meter Sets

2. E. (2): Revised to "Gas Supervisor is to maintain records of all inside meter sets. List of locations with inside meters will be maintained in Maximo."

2. E. (8)(g) & (h): Added See METR 2.20 for pictures of banded regulators and substandard regulators

2. E. (9): Revised to "If any of the above deficiencies are noted, they will be repaired immediately or reported within ClickMobile for follow-up action."

Eliminated notifying Gas Supervisor since Maximo will schedule and track follow-up action.

LEAK 2.08	<p>Leak Survey - Equipment</p> <p>2. Flame Ionization Instrument - Portable</p> <p>2. (E): Revised to "Ameren Illinois' FI Instrument shall be inspected and calibrated on a monthly basis and recorded in Maximo. Instrument inspection and calibration shall be performed in accordance with manufacturer's operating manual for the FI unit being used. See LEAK 4"</p> <p>3. Gas Detection Equipment</p> <p>3. F.: Revised to "Instrument shall be inspected and calibrated on a monthly basis and recorded in Maximo."</p> <p>4. Combustible Gas Indicator (CGI)</p> <p>4. E.: Revised to "CGI is to be calibrated monthly and recorded in Maximo"</p>	<p>January 1, 2014</p>	<p>December 1, 2014</p>
--------------	---	----------------------------	-----------------------------

<u>LEAK 2.09</u>	<p>Walking Leak Survey</p> <p>1. J. Regulator Station, Farm Taps, Outside Meter Sets</p> <p>1. J. (9): Revised to "Surveyor will initiate a Leak Investigation task within ClickMobile."</p> <p>1. K. Fenced Gas Facilities Inspected Annually</p> <p>1. K. (2): Changed to state inspection is documented in Click-Mobile on Leak Survey Inspection Task.</p> <p>1. K. (2)(b) & (c): Deleted these two leak survey map items since they are no longer applicable with the implementation of Maximo.</p> <p>1. M. Inaccessible Facilities</p> <p>1. M. (1): Revised to "Facilities that cannot be accessed during the leak survey shall be reported as a status Inaccessible within ClickMobile."</p> <p>1. N. Gas Detection Instrument or FI Unit Indicates a Possible Leak</p> <p>1. N. (1)(a): Added the Bascom Turner Gas Rover as another survey instrument that has capabilities of classifying a leak.</p> <p>1. N. (1)(c): Added the Ameren Illinois emergency phone number 1.800.755.5000 for the contract leak surveyor to call to report a leak.</p> <p>Instead of the contract leak surveyor attempting to contact the Gas Supervisor, SMR Team felt it would be best and quicker to call of the Contact Center to report a leak.</p> <p>1. N. (1)(e): Revised to "Surveyor will initiate an Leak Investigation task in ClickMobile."</p>	<p>January 1, 2014</p>	<p>December 1, 2014</p>
--------------------------------------	---	----------------------------	-----------------------------

1. N. (2) If leak surveyor detects gas entering a building, Class 1 leak:

1. N. (2)(a): Added the Ameren Illinois emergency phone number 1.800.755.5000 for the contract leak surveyor to call to report a leak.

Instead of the contract leak surveyor attempting to contact the Gas Supervisor, SMR Team felt it would be best and quicker to call of the Contact Center to report a leak.

1. N. (2)(f): Revised to "Surveyor will initiate an Leak Investigation task in ClickMobile."

1. N. (3): Added "appears to be" so now reads "If leak surveyor detects a gas leak that appears to be non-hazardous, Class 2 or Class 3:"

1. N.(3)(c): Revised to "Surveyor will initiate an Leak Investigation task in ClickMobile or a leak surveillance within ClickMobile if the leak is already known."

1. N. (4) If the leak surveyor detects gas on customer piping.

1. N. (4)(a): Added the Ameren Illinois emergency phone number 1.800.755.5000 for the contract leak surveyor to call to report a leak.

Instead of the contract leak surveyor attempting to contact the Gas Supervisor, SMR Team felt it would be best and quicker to call of the Contact Center to report a leak.

1. N. (4)(d): Revised to "Leaks on customer facilities shall be documented within ClickMobile by selecting the Additional Work - Leak on Customer Facilities task."

1. N. (5) If leak surveyor detects an indication of gas from a valve box or pit which contains a gas facility:

1. N. (5)(c): Revised to "Leak will be classified and documented within ClickMobile."

1. O. Weather Limitations

1. O. (g): Changed to " Gas Supervisor and Leak Technician are responsible for determining if weather is unacceptable for surveying."

LEAK
2.10

Leak Surveys - Mobile Leak Survey

1. Mobile Flame Ionization Leak Survey

1. F. (1): Added the Ameren Illinois emergency phone number 1.800.755.5000 for the contract leak surveyor to call to report a leak.

1. F. (3): Revised to "Surveyor will complete a Leak Investigation task within ClickMobile."

1. G. If leak appears non-hazardous, Class 2 or Class 3 1. G. (1): New - "Surveyor may continue with the survey until it is

October 1,
2011

December 1,
2014

UNCONTROLLED IF PRINTED

convenient to access their vehicle to return with the CGI and probe rod to do a full investigation and classification."

1. G. (2): New - "Surveyor shall follow the procedures contained in LEAK 2.04, Leak Classification and Surveillance in the O&M Manual."

1.G. (3): New - "Surveyor will initiate a Leak investigation task within ClickMobile, or a Leak Surveillance task if the leak has already been identified on the ClickMobile Map."

SMR Team added these to be consistent with the Walking Leak survey procedures. 3. Optical Methane Detector (OMD) Survey

3. G. (1): Added the Ameren Illinois emergency phone number 1.800.755.5000 for the contract leak surveyor to call to report a leak.

3. G. (3): Revised to "Surveyor will initiate a Leak Investigation Task within ClickMobile."

3. H. If leak appears to be non-hazardous, Class 2 or Class 3
3. H. (1): New - "Surveyor may continue with the survey until it is convenient to access their vehicle to return with the CGI and probe rod to do a full investigation and classification."

3. H. (2): New - "Surveyor shall follow the procedures contained in LEAK 2.04, Leak Classification and Surveillance in the O&M Manual."

3. H. (3): New - Surveyor will initiate a Leak investigation task within ClickMobile, or a Leak Surveillance task if the leak has already been identified on the ClickMobile Map."

SMR Team added these to be consistent with the Walking Leak survey procedures.

LEAK
2.11

Leak Surveys - Records and Maps

1. Additional Survey Checks

1. A.: Added - "Deficiencies are documented within ClickMobile and are tracked in Maximo." 1. C.: Revised to "Deficiencies and leaks found on Ameren Illinois facilities are to be reported each day within ClickMobile "

1. D.: Revised to "Deficiencies that are reported are tracked in Maximo." 2. Maps and Records 2. A.: Revised to "Electronic maps in ClickMobile will be utilized for all transmission, high pressure distribution, and distribution leak surveys."

2. C.: Revised to "Leak Surveyor(s) will record each day's survey by lassoing section(s) of the pipeline and facilities that were leak surveyed within ClickMobile."

Deleted the practice of color highlighting on leak survey maps daily surveys since maps are now electronic.

2. E.: Changed to "Transmission Leak Survey maps and records will be maintained in Maximo for life of facility" 2. F.

January 1,
2014

December 1,
2014

Changed to "Maps and records for all distribution leak surveys will be maintained in Maximo for six (6) years."

2. G. Residential Yard Line and Inside Meter Set Survey Records

2. G. (1): Revised to "Gas Engineer or Gas Supervisor maintains the location of each Yard Line to be surveyed within Maximo." 2. G. (1)(d): New - "When the entire survey is complete, the surveyor will complete the task in ClickMobile for the yardline survey." 2. G. (2); Revised to "Gas Engineer or Gas Supervisor maintains the location of each Inside Gas Meter outside the Business District within Maximo." 2. G.(2)(c):) : New - "When the entire survey is complete, the surveyor will complete the task in ClickMobile for the yardline survey." 2. G. (3): Revised to "Completed surveys and associated records will be maintained in Maximo."

LEAK 2.13	<p>Calibration of Gas Detection Instruments</p> <p>7. Records</p> <p>7. A.: Revised to "The monthly calibration information for the CGI and FI units is required and shall be maintained for six (6) years in Maximo."</p>	<p>January 1, 2013</p> <p>December 1, 2014</p>
LEAK 2.14	<p>Special Distribution Leak Survey</p> <p>3. Survey</p> <p>3. D. Revised to "A leak investigation within ClickMobile shall be initiated for each new leak found, and a leak surveillance should be completed within ClickMobile for existing leaks found during the survey accordance with LEAK 2.05."</p> <p>3. E.: New : "The Senior Gas Specialist will be responsible for maintaining all documentation of leaks and tracking leaks associated with the Special Distribution Leak Survey within Maximo."</p>	<p>October 1, 2011</p> <p>December 1, 2014</p>
<u>LEAK</u> <u>4</u>	<p>Forms and Reference Materials</p> <p>Deleted Forms:</p> <p>GCS Leak Case Field Report (Form Number 570NS)</p> <p>Leak Survey Daily Report Form</p> <p>Mechanical Fitting Leak Data Form</p> <p>These forms have been incorporated in ClickMobile and will be completed electronically.</p>	<p>January 1, 2014</p> <p>December 1, 2014</p>
METR 2.14	<p>Electronic Corrector Inspection</p> <p>7. Atmospheric Corrosion</p> <p>7. A.: Revised to "Gas metering facilities that have any of the corrosion control inspection activities marked (Y) for YES shall be documented within ClickMobile. Information will be trans-</p>	<p>January 1, 2013</p> <p>December 1, 2014</p>

UNCONTROLLED IF PRINTED

ferred to Maximo for tracking and scheduling of any follow-up actions that are required."

Former 7. B: Deleted the review by the Gas Supervisor and sending information to Superintendent Corrosion Control since Maximo will know perform this function when atmospheric corrosion is noted. 7. B.: Revised to "The corrective action work required will follow the procedures identified in CORR 1. Maximo will track and maintain a record of corrective action."

This same change is valid for Pressure Factor Verification below.

METR 2.19	<p>Pressure Factor Verification</p> <p>7. Corrosion Control Inspection Follow-up</p> <p>7. A.: Revised to "Gas metering facilities that have any of the corrosion control inspection activities marked (Y) for YES shall be documented within ClickMobile. Information will be transferred to Maximo for tracking and scheduling of any follow-up actions that are required."</p> <p>Former 7. B: Deleted the review by the Gas Supervisor and sending information to Superintendent Corrosion Control since Maximo will know perform this function when atmospheric corrosion is noted.</p> <p>7. B.: Revised to "The corrective action work required will follow the procedures identified in CORR 1. Maximo will track and maintain a record of corrective action."</p>	January 1, 2012	December 1, 2014
METR 2.22	<p>Pressure Gauges</p> <p>2. Ameren Illinois Pressure Gauge Definitions 2. B.: Revised to "Test Gauge - A pressure gauge with accuracy of ± 0.5%, of full scale, that is periodically verified for accuracy and utilized for activities that require reading accuracy. A test gauge usually has features such as a definitive zero, mirrored scale, and knife-edged pointer. Test gauges are entered and maintained in Maximo. Test gauges are shown in Specialized Tools and Equipment in Gas Operations and Services website on Scholar." 7. Recordkeeping 7. Revised to "The verification and calibration history for all test gauges and calibrating test gauges shall be maintained in Maximo."</p>	April 1, 2013	December 1, 2014
ODOR 0	<p>ODOR 4 Forms and Reference Materials</p> <p>Reference Materials:</p> <p>Deleted Reference 9 - Ameren GCS Odorization Module User's Guide</p>	January 1, 2013	December 1, 2014
ODOR 2.02	<p>Odorization Operation</p> <p>2. Odorization Location 2. D.: Revised to "Each odorizer will be tracked in Maxim." 4. Odorization Operation and Inspection 4.</p>	January 1, 2014	December 1, 2014

UNCONTROLLED IF PRINTED

B.: Revised to "Bypass, drip and positive injection odorizers shall be inspected monthly and entered in ClickMobile."

4. D. (2): Revised to "Odorization rates will be calculated and entered into Maximo when gas delivery data is available from Gas Control."

4. D. (4): Revised to "If odorization rate is less than 0.65 or greater than 1.25 Lbs/MMCF, the odorizer should be checked and corrective action remarks entered within ClickMobile and Maximo." 7. Records 7. A.: Revised to "Monthly odorization rates shall be maintained in Maximo for a period of 3 years. Paper documents can be used as supplemental information."

ODOR 2.03	<p>Odorant Intensity Testing</p> <p>2. Odorant Intensity Testing</p> <p>2. B.: Revised to "Odorant Intensity checks will be completed once each calendar month at sampling sites identified by the Gas Supervisor and designated in Maximo."</p> <p>3. Intensity Test Instruments and Readings</p> <p>3. D.: Revised to "Calibration shall be performed once each calendar year not to exceed twelve (12) months and recorded in Maximo."</p> <p>3. I.: Revised to "If a reading outside this range is found, it shall be promptly reported to the Gas Supervisor and promptly investigated. Corrective action shall be documented within ClickMobile and Maximo."</p> <p>5. Selection of Odorant Intensity Test Sites</p> <p>5. C. (2): Revised to "Pre-determined specific test point locations will have Test Point ID's established in Maximo for each odorized system."</p> <p>8. Records</p> <p>Revised to "Records shall be retained in Maximo for three (3) years."</p>	<p>January 1, 2013</p>	<p>December 1, 2014</p>
ODOR 2.05	<p>Odorant Intensity Testing Flowchart</p> <p>References to GCS have been replaced with ClickMobile</p>	<p>January 1, 2014</p>	<p>December 1, 2014</p>
ODOR 4	<p>Forms and Reference Materials</p> <p>Reference Materials:</p> <p>Deleted Reference 9 - Ameren GCS Odorization Module User's Guide</p>	<p>January 1, 2013</p>	<p>December 1, 2014</p>
PTRL 2.01	<p>Transmission Patrols</p>	<p>July 1, 2014</p>	<p>December</p>

2. Transmission Main Patrol 2. A.: Revised to "Class locations, HCS's and patrol/sub-patrol designation will be attributes on main segments within the ClickMobile maps."

Since maps will now be in Maximo, Pipeline Integrity group will no longer be providing the maps to the Operating Areas.

2. C.: Revised to "Pipeline facility patrols may be performed in conjunction with the leak surveys; however, they must be documented separately within ClickMobile for their respective tasks."

3. Patrol Requirements

3. B.: Revised to "Document within ClickMobile of any condition that requires immediate notification to Gas Supervisor and follow-up action. Items such as:"

3. B. (2): Revised to "Indication of gas coming from casing vent(s), initiate a leak investigation within ClickMobile."

3. C.: Revised to "Document within ClickMobile locations where;"

3. C. (10): Format change only. Made "Any corrective action taken during the patrol." a bullet point under 3. C. an item that should be documented in ClickMobile.

4. Processing Data

Former 4. B. has been removed. Gas Supervisor does not have to document notification of data correction. Maximo will handle this.

4. B. (5): Revised to "Provide the new or updated patrols/sub-patrols information to the appropriate personnel for updating main segment(s) attributes within the GTECH mapping system."

4. B. (6): New - "Notify Gas Supervisor of updated class locations, HCA's, and requirements."

Pipeline Integrity group will provide new and updated patrol and HCA information to those who maintain GTECH, electronic mapping. Pipeline Integrity group no longer will maintain maps.

5. Records

5. A.: Revised to "The results of the pipeline facility patrols shall be updated following a patrol and maintained in Maximo."

PTRL
2.02

Critical Area Patrols

July 1,
2014
De-
cem-
ber 1,
2014

3. Critical Area Patrols

3. A.: Revised to "Critical areas on high pressure distribution and distribution mains shall be identified and maintained in Maximo."

4. Processing Data 4. A.: Revised to "Document within Click-Mobile any changes in conditions that could adversely affect the integrity of the gas facilities." 5. Records 5. A.: Revised to

"The results of the pipeline facility patrols shall be updated following a patrol and maintained in the Maximo."

REGS 0	REGS 2.05 Gas Compliance System Inspection Form has been removed.	January 1, 2014	December 1, 2014
REGS 1	<p>2. Regulator Station Inspection Schedule</p> <p>2. C.: Delete the 3 year inspection interval. Now the Supervisor Gas Tech Services or Gas Supervisor has the discretion of scheduling a primary inspection at a 1 or 5 year interval.</p> <p>3. Regulator Station Engineering Evaluations</p> <p>3. F.: Revised to "The calculations required to perform the evaluation can be performed manually or by using the evaluation function in Maximo."</p> <p>4. Records 4. A.: Revised to "All regulator station equipment data, inspection information, and engineering evaluation history shall be maintained in Maximo."</p>	January 1, 2014	December 1, 2014
REGS 2.01	<p>Regulator Station Inspections</p> <p>1 B. Annual inspection requires at a minimum an Operational Inspection which: 1. B. (3): Revised to "Verifies the overpressure protection equipment (OPP) activates at the equipment's set point that is in Maximo."</p> <p>1. E.: Revised to "Inspections should be performed using Click-Mobile for each station as a guide."</p> <p>1. G.: Revised to "The Operational and Primary Inspections shall be documented in ClickMobile."</p> <p>3. Operational Inspection</p> <p>3. C. Regulator Station with Relief Valve</p> <p>3. C. (1): Revised to "Regulator station equipment should be checked for leaks before and after inspection. A leak investigation shall be initiated within ClickMobile and is required for all leaks found during annual station inspection."</p> <p>3. C. (3): Revised to "Verify regulator and relief valve installed at the station matches the equipment listed in Maximo."</p> <p>3. C. (4): Revised to "Confirm pressure settings indicated within Maximo". 3. C. (5): Revised to "Any discrepancy in equipment or changes that are made to the documented pressure settings should be verified with the GTS Supervisor and indicated on the inspection form within ClickMobile."</p> <p>3. C. (8) Final Inspection 3. C. (8)(d): Revised to "Document within ClickMobile the maintenance work performed or that</p>	January 1, 2014	December 1, 2014

needs to be scheduled." 3. C. (8)(f): Revised to "Make final check"

3. D. Passive Monitor Regulator Station (both upstream and downstream) 3. D. (1): Revised to "Regulator station equipment should be checked for leaks before and after inspection. A leak investigation shall be initiated within ClickMobile and is required for all leaks found during annual station inspection."

3. D. (3): Revised to "Confirm pressure settings indicated within Maximo". 3. D. (4): Revised to "Any discrepancy in equipment or changes that are made to the documented pressure settings should be verified with the GTS Supervisor and indicated on the inspection form within ClickMobile."

3. D. (8) Final Inspection 3. D. (8)(d): Revised to "Document within ClickMobile the maintenance work performed or that needs to be scheduled." 3. D. (8)(f): Revised to "Make final check"

3. E. Working Monitor Regulator Station

3. E. (1): Revised to "Regulator station equipment should be checked for leaks before and after inspection. A leak investigation shall be initiated within ClickMobile and is required for all leaks found during annual station inspection." 3. E. (3): Revised to "Confirm pressure settings indicated within Maximo". 3. E. (4): Revised to "Any discrepancy in equipment or changes that are made to the documented pressure settings should be verified with the GTS Supervisor and indicated on the inspection form within ClickMobile."

3. E. (8) Final Inspection 3. E. (8)(d): Revised to "Document within ClickMobile the maintenance work performed or that needs to be scheduled." 3. E. (8)(f): Revised to "Make final check"

4. Primary Inspection 4. E.: Revised to "Set the regulator to the correct set-point contained within Maximo." 4. F. Final Inspection 4. F. (4): Revised to "Document within ClickMobile the maintenance work performed or that needs to be scheduled." 4. F. (6): Revised to "Make final check"

6. Atmospheric Corrosion See CORR 1

6. C.: Revised to "Document on the ClickMobile inspection form whether or not atmospheric corrosion or disbonded coating is found on above grade piping."

7. Gas Leakage

7. C. Documentation of leak survey results 7. C. (1): Revised to "For fenced stations in a Class 1 or Class 2 location, results can be documented on the ClickMobile pressure control station inspection form."

7. C. (2): Revised to "For fenced stations in a Class 3 location, bi-annual leak surveys are issued through Maximo and should be documented within ClickMobile. See LEAK 2.09" 7. D.: Revised to "Any below grade gas leak that is identified during the

UNCONTROLLED IF PRINTED

inspection shall be documented within ClickMobile by initiating a leak investigation or completing a leak surveillance on an existing leak." 7. E.: Revised to "Class 3 leaks repaired at the time of the inspection shall be documented within ClickMobile by initiating a leak investigation."

7. F.: Revised to "A separate leak investigation is required for an above grade Class 1 leak identified during the inspection. See LEAK 2.04"

REGS 2.05	Gas Compliance System Inspection Forms - REMOVED This section is being removed from the O&M since Regulator Station inspections will be completed on an inspection form within ClickMobile. The inspection information will be maintained in Maximo.	January 1, 2011	December 1, 2014
REPR 1	<p>1. H. If it is not feasible to make permanent repair</p> <p>1. H. (3): Revised to "The leak repair initiated in ClickMobile should have note indicating it was a Make Safe repair."</p> <p>1. H. (4): Deleted attaching copy of the permanent repair DO-JM to the Gas Leak Case Field Report since the GLCFR no longer exists.</p> <p>2. Leak Repairs</p> <p>2. F.: Revised to "If a leak is caused by corrosion, a Corrosion and Steel Damage Evaluation shall be completed within ClickMobile by the appropriate and qualified individual. See CORR 2.31"</p> <p>4. Steel Pipe Repair Methods</p> <p>4. L. Encapsulation</p> <p>4. L. (2) A steel pipe with welded cap is an acceptable means of encapsulating a leaking or abandoned fitting.</p> <p>4. L. (2)(b): Revised to "Pressure test shall be documented on the ClickMobile leak repair form."</p> <p>10 Repair Records</p> <p>10. A. Pressure Tests</p> <p>10. A. (2): Deleted "The actual test pressure and actual test duration shall be documented on the Leak Case Field Report." Leak Case Field Report has been eliminated.</p> <p>10. A. (2): Revised to "The actual test pressure and duration should be recorded in ClickMobile and retained in Maximo for repairs associated with a gas leak."</p> <p>10. A. (3): Revised to "Records pertaining to leak repairs shall be maintained in Maximo for the life of the facility.</p> <p>10. B. Weld Test</p> <p>10. B. (3): Revised to "The information shall be maintained in Maximo.</p>	July 1, 2014	December 1, 2014

REPR 2.01	<p>Compression Couplings</p> <p>6. Records</p> <p>6. B.: The actual test pressure and actual test duration shall be documented within ClickMobile on the leak repair form."</p>	January 1, 2014	December 1, 2014
RNST 2.01	<p>Reinstating Main and Services</p> <p>6. Records</p> <p>6. A.: Revised to "All pressure test information will be maintained in Maximo."</p>	July 1, 2014	December 1, 2014
SERV 0	<p>Changed the name of SERV 2.06 to Gas Service Card</p> <p>SERV 4 Forms and Reference Materials</p> <p>Deleted all of the Gas Service Transaction Cards/Sheets</p>	January 1, 2014	December 1, 2014
SERV 1	<p>2. Depth</p> <p>2. B. (3): Revised to "Location of where service line buried depth is less than eighteen (18) inches should be recorded on the Gas Service Card Form within ClickMobile. Method of protection should also be recorded in the comments section on the Gas Service Card Form within ClickMobile."</p> <p>2. C.: Revised to "Where the required minimum cover for the service line cannot be provided, Safety Barrier Tape shall be installed approximately six (6) inches below the surface to provide advance warning to excavators. Additionally, location of where service line buried depth is less than eighteen (18) inches should be recorded in the comments section of the Gas Service Card Form within ClickMobile. Method of protection should also be recorded in the comments section on the Gas Service Card Form within ClickMobile."</p> <p>4. Underground Clearances</p> <p>4. A. (2): Revised to "When minimum clearance cannot be achieved, note the reduced clearance in the comment section on the Gas Service Card Form within ClickMobile."</p> <p>13. Records</p> <p>13. A.: Revised to "All service line installations, repairs, and retirements shall be recorded on the Gas Service Card Form within ClickMobile."</p> <p>Former 13. B.: Deleted entering service information into CSS. Service attributes are now retained in GTECH.</p> <p>13. B.: Revised to "Gas Service Card Forms are completed within ClickMobile and retained within Maximo."</p>	January 1, 2014	December 1, 2014
SERV 2.04	<p>Yardlines</p> <p>6. Yardline Records</p>	January 1, 2014	December 1, 2014

UNCONTROLLED IF PRINTED

	6. A.: Revised to "The Gas Supervisor will maintain a list of all existing yardlines in Maximo."		ber 1, 2014
	6. C.: New - "Yardline survey information will be entered within ClickMobile and maintained in Maximo. See LEAK 2.11"		
SERV 2.06	<p>Gas Service Card changed from Gas Service Transaction Card</p> <p>This section has been significantly revised since the Gas Service Card is contained within ClickMobile and the former Gas Service Transaction Card/Sheet has been eliminated.</p> <p>1. A.: Gas Service Card replaces Gas Service Transaction Card</p> <p>1. C.: New "The ClickMobile Gas Service Form should be used to collect Service Attributes. ClickMobile service attribute information has been modified from those on the former Gas Service Transaction Card."</p> <p>2. Gas Service Card Form - Replaces Gas Service Transaction Card</p> <p>2. A.: Revised to "The Gas Service Card Form shall be completed by gas field personnel any time a service is touched and a service attribute has changed. The form can also be used to correct existing service attributes. The following list identifies the most common instances when a Gas Service Card Form should be completed by gas field personnel."</p> <p>Added the card can be used to record corrections on existing service attributes.</p> <p>2. A. (1): Revised to "New Installation of a service line"</p> <p>2. A. (2): Revised to "Replacement of a gas service - partial. Deleted "total replacement" which will now be reported as a New Installation.</p> <p>2. A. (3): Revised to "Extension of a gas service" from Relocation</p> <p>Revision made to match categories in ClickMobile.</p> <p>2. D.: Added Corrosion Control to the groups that may use the service information.</p> <p>3. Inserted New - Service Sketches</p> <p>3. A.: New "Service Sketch should be completed within ClickMobile for all new installations, modifications, retirements and repairs to record and/or clarify work performed."</p> <p>3. B.: New "ClickMobile Sketch tool should be used but if for some reason a service sketch cannot be completed in ClickMobile, the sketch can be made on a copy of the former Gas Service Transaction Card then scanned and attached to the Work Order task assigned. The following information should be provided with the sketch."</p> <p>3. B. (1) Address of the service</p>	Janu- ary 1, 2014	De- cem- ber 1, 2014

- 3. B. (2) City or town
- 3. B. (3) Premise Number - if available
- 3. B. (4) Name of the person responsible for performing the work
- 3. B. (5) Employee Number of the responsible person performing the work
- 3. B. (6) Contractor Company if an outside contractor performed the work
- 3. B. (7) Date the work was performed
- 3. B. (8) Remarks

4. Completion Instructions

4. A.: New "The ClickMobile Gas Service Form contains required fields that must be accurately completed. However, it is good practice to record all information that is known about the service."

4. B. New "If the Gas Service Transaction Card/Sheet is being used for the service sketch, only the information listed under Service Sketches, above, should be included with the sketch. Service attributes should not be entered on the Transaction Card."

4. C.: New "Sample of a Gas Service Transaction Card used for Service Sketch"

Lines that are to be completed are indicated with the number associated with the information shown under Service Sketch. None of the service attribute information is to be entered on this card. A separate Sketch Card may be developed in the future if the need arises.

5. Distribution

5. A.: New "Gas Service Card Form shall be completed within ClickMobile."

5. B.: New "An email will be sent the appropriate poster who will access Maximo and retrieve the Service Request task and Service Sketch. The poster will post a service in G/Tech when necessary and maintain the Maximo Service Asset number for the service in G/Tech."

5. C.: New "The Gas Service Card Form information will be maintained in Maximo."

Removed:

Former 4 Service Transaction Card section

Former 5 Completion Instructions section for the Gas Service Transaction Card

These were removed since the Gas Service Transaction Card/ Sheets have been replaced with the electronic Gas Service Card contained in ClickMobile.

SERV
2.07

Gas Service G/Tech Mapping

Janu-
ary 1,
2014
De-
cem-
ber 1,
2014

1. B.: Revised to "Service attributes are collected on a Gas Service Card Form within ClickMobile and retained in Maximo. Maximo maintains the official service attributes record. The official gas service drawing is retained in Maximo as well."

1. C.: Revised to "G/Tech will maintain the relationship between the CSS Service Drop number and the Maximo Asset number."

2. Map a Premise

2. A." Revised to "The premise symbol represents a gas premise. When premise symbol is placed, the peak of the house will point north. It is not necessary to rotate the symbol. The Gas Service Card Form drawing will portray the premise's actual location and direction."

4. Map a Gas Service

4. A.: Revised to "Gas service attributes are maintained in Maximo."

4. D.: Revised to "The graphical line represents a service not the physical path to the premise. The physical path, dimensions, material, and other service attributes are captured on the Gas Service Card Form."

4. H.: Revised to "For service lines being mapped, the correct CSS service drop number and the correct Maximo service asset number should be associated to the service."

4. I.: Inserted new "The CSS Service Drop number will be associated to the Maximo Asset number in G/Tech."

4. J.: Revised to "Excess flow valves, curb valves, valve tees, and other fittings should not be mapped in G/Tech. The fitting information is maintained in Maximo." 5. Farm Tap Services

5. A.: Revised to "The entire service line from the main to the premise will be posted as one graphic service line and follow gas service mapping practice. The physical path, dimensions, material, and other service attributes are captured on the Gas Service Sketch within Click Mobile."

5. C.: Revised to "The entire service line from the main to the premise will be posted as one graphic service line and follow gas service mapping practice. The physical path, dimensions, material, and other service attributes are captured on the Gas Service Sketch within Click Mobile."

6. Branch Service

6. C.: Revised to "Care should be taken to assign the proper Service Drop number and Maximo Service Asset number to the correct service segment."

8. Retired Service

8. B.: Revised to "Maximo will maintain the retired material and date."

8. C.: Revised to "The Service Drop number and Maximo Asset number should stay with the retired service to maintain relationship to the service attribute record in Maximo."

9. Stub Service

9. B.: Revised to "An existing service drop number and Maximo Service Asset number should remain associated with the stub service. This will allow for reference for tapping information, location dimensions and material records."

SERV 4	Forms and Reference Materials Removed all of the Gas Service Transaction Card/Sheets These Cards/Sheets are no longer to be used. Service information will now be entered on the Gas Service Card contained within ClickMobile.	October 1, 2011	December 1, 2014
VALT 2.01	Inspecting Vaults and Pits 5. Vault Inspection Schedule 5. B.: Revised to "Inspection and deficiencies will be recorded within ClickMobile on the appropriate Regulator Station or Valve Inspection forms." 6. Inspection Records 6. A.: Revised to "All inspections of vaults with an internal volume of two hundred (200) cubic feet or more shall be maintained in Maximo."	January 1, 2011	December 1, 2014
VALV 1	4. Emergency Valve Inspections 4. B.: Revised to "Inspections will be recorded in ClickMobile and maintained for the life of the valve in Maximo."	January 1, 2014	December 1, 2014
VALV 2.01	Valve Installation 2. Valve Identification 2. B.: Revised to "Valve numbering is to be maintained and recorded in Maximo." 5. Non-Emergency Valves 5. E.: Revised to "Valve can be entered in Maximo and designated as Non-Emergency Valve." 5. E. (1): Revised to "Be cautious when entering a valve in Maximo that the correct Designation is denoted and an Emergency Valve is not erroneously entered as Non-Emergency. Some areas initially enter a valve as Non-Emergency until the valve is initially inspected, then the valve designation must be changed to Emergency when the inspection is entered in order for annual inspection to be scheduled."	January 1, 2014	December 1, 2014

5. E. (3): "Revised to Maximo will maintain a listing, location, and attributes of Non-Emergency valves."

5. E. (4) thru (6): These items were deleted since they referred to GCS instructions which are no longer valid.

5. F.: Revised to "If a below grade non-emergency valve is used to isolate or sectionalize gas main segments of a gas distribution system or transmission system during an emergency situation, the valve will be designated as an Emergency Valve after the emergency situation has been resolved. An Emergency Valve ID shall be assigned. The valve shall be entered into Maximo and on the electronic gas system map. In the comments section of the ClickMobile valve inspection form, enter "valve was used during an emergency situation". This does not include a below grade service line valve used to shut down a service line."

VALV
2.02

Valve Inspection and Maintenance

July 1, 2012
December 1, 2014

2. Valve Inspections 2. C.: Revised to "Review, verify, correct or furnish missing data on the ClickMobile map and inspection form."

2. K.: Revised to "Unknown or inaccurate valve description and installation data that can be accessed without excavation or disruption of service shall be verified and entered onto the ClickMobile inspection form." 3. Valve Maintenance 3. B.: Revised to "Verify that the valves are properly shown on the reference maps such that they can be easily located. Measurements associated with the sketch in ClickMobile should be checked to ensure they are reasonably correct." 4. Follow-up Maintenance 4. D.: Revised to "Gas Supervisor should review the inspection sheets and other maintenance work listed in Maximo. Maintenance work that can be reported during valve inspection includes: replacement of valve number tags, miscellaneous work, mechanical maintenance, lubricate valve, new insulator needed, new gasket needed, data correction, clear vegetation, clear valve box, clean internal (flush), clean external, bond wire, and align valve box."

5. Records

5. A.: Revised to "The results of the emergency valve inspection shall be recorded, by the qualified gas field personnel performing the inspection, on the ClickMobile inspection form."

Former 5. B. Deleted information regarding entering inspection results on hand-held, lap top, MDT or PDA that has access to GCS Valve Inspection module. This is no longer applicable.

5. B.: Revised to "Any data correction or update should be reported on the ClickMobile inspection form. Gas Supervisor or Gas Engineering is responsible for ensuring data corrections are made within Maximo."

5. C.: Revised to "The results of the emergency valve inspection shall be entered into ClickMobile and maintained within Maximo."

5. D.: Revised to "The results of the inspection shall be maintained for the life of the facility."

Supersedes: July 1, 2014

CHANGE SUMMARY

July 1, 2014

Change Summary July 1, 2014

Docu- ment	Change Summary	Previous Docu- ment Dated	Current Docu- ment Dated
<u>CONS</u> <u>0</u>	Table of Contents Added CORR 1 2. Construction Records, Maps, and Operating History	Janu- ary 1, 2013	July 1, 2014
<u>CONS</u> <u>1</u>	Requirements Inserted new section: 2. Construction Records, Maps, and Operating History A. Construction records, maps and operating history are available to gas field personnel assigned to safely operate the pipeline facilities and respond to emergencies. B. Construction records and operating history are typically located based on the type of facility and the area of operations responsible for the construction and/or maintenance of the facility. Much of the operating history is maintained in the Ameren Illinois gas compliance system. Gas field personnel can request the information through their Supervisor. C. Gas system maps are available electronically through the Ameren Illinois electronic mapping system. Gas field personnel have access to these maps via truck mounted mobile data terminals, lap top computers, or office based computers. This section was added to comply with requirements in Part 192.605. Language had not been included in the O&M that stated construction records, maps, and operating history are available to the operating personnel. 5. Construction Inspector B.: Added Gas Field Personnel and Management Employees to those that need to attend Gas Construction Training prior to inspecting gas construction work. C. Added new: "Construction Inspector Training will consist of a review of O&M Plan procedures for construction tasks, Gas Construction Oversight procedures, related forms and documentation requirements, and a review of Quality Assurance Field Inspection forms. An exam will be administered after the completion of training." These additions were made by the Gas Training group in response to a Notice of Amendment (NOA) issued by the ICC stating the O&M didn't include who should attend Gas Construction Inspector Training and what is included in the training,	Janu- ary 1, 2014	July 1, 2014

CORR 0	<p>Table of Contents</p> <p>CORR 1</p> <p>Inserted a new item 3. Corrective Action</p>	Janu- ary 1, 2014	July 1, 2014
CORR 1	<p>Requirements</p> <p>2. Cathodic Protection Measurements</p> <p>2. A.: Grammatical: Combined the two sentences to specify reference cell is a copper-copper sulfate.</p> <p>3. Corrective Action: Inserted a New Section: Moved CORR 1 7. I. language moved into its own section.</p> <p>Corrosion SMR group felt Corrective Action should be its own section.</p> <p>4. Cathodic Protection of New and Replacement Pipeline Facilities</p> <p>4. B.: Changed the required protection level to -0.900 volts from -0.850 volts to be consistent with the threshold at which corrosion control personnel are to be notified.</p> <p>6. External Corrosion</p> <p>6. B.: Revised to reflect it is no longer necessary to send copies of the Buried Pipe Examination form to Corrosion Control personnel when there is a reading of -0.900 volts or less. Corrosion control personnel receive daily reports list locations with readings less negative than -0.900.</p> <p>Corrosion SMR team felt sending copies of the Buried Pipe Examination form was an unnecessary waste of time and resources.</p> <p>13. Atmospheric Corrosion</p> <p>13. B. Monitoring</p> <p>13. B.(1): Listed those gas facilities that have annual compliance inspections which include checking for atmospheric corrosion.</p> <p>13. B.(2): Listed those gas facilities that are inspected on a 4 year cycle for atmospheric corrosion.</p> <p>This revision merely identifies at which interval atmospheric corrosion is performed. Ameren Illinois has a four year atmospheric corrosion inspection waiver for its gas facilities. However, there are gas facilities that have annual inspection requirements such as transmission leak surveys, regulator station inspections, emergency valve inspections, etc. Distribution and high pressure distribution facilities are leak surveyed on a 4 year cycle. Inspecting for atmospheric corrosion is part of all of these required inspections.</p> <p>13 B.(5): Deleted having meter readers checking for and reporting atmospheric corrosion on meter sets.</p>	Janu- ary 1, 2014	July 1, 2014

Since Company performs distribution leak surveys on a 4 year cycle and checking for atmospheric corrosion on meter sets is part of the leak survey process, it is no longer necessary for meter readers to perform that function. Leak surveyors are better trained in identifying atmospheric corrosion.

CORR 2.01	<p>Cathodic Protection Design</p> <p>5. Insulating Materials</p> <p>5. B. Flange Insulation</p> <p>Table for Class 600 Flange, Insulated: updated the stock codes for bolts used in 8 inch, 10 inch, and 12 inch flanges. For the 8 inch flange, 1-1/8" x 8-1/2" bolt is 21 96 234; for a 10 inch flange, 1-1/4" x 9" bolt is 21 96 233, and for a 12 inch flange, 1-1/4" x 9-1/2" bolt is 21 93 235. These bolts are stocked at the MDF and do have minimum quantity established.</p> <p>Gas Engineering requested these bolts be stock coded and a supply maintained at the MDF. These bolts are not readily available at local vendors.</p>	Janu- ary 1, 2013	July 1, 2014
CORR 2.02	<p>Anode Requirements</p> <p>1. General</p> <p>1. D.: Deleted "Anode shall not be installed at or within 10 feet of a test station attachment to steel pipe."</p> <p>1. D.: Inserted a new item to provide additional instructions for anode installation.</p> <p>"1. D.: Anode can be placed vertically or horizontally and a minimum of six (6) inches below the bottom of the steel pipe. Anodes may be installed in multiple groupings. No more than 2 anodes shall be installed in an excavation unless 10 feet of spacing can be maintained between the anodes. If multiple connections are made on the pipe, the connections should be at least six (6) inches apart.</p> <p>1. E.: "Anode should be placed as far away from the pipe as the excavation safely allows up to the length of the anode lead wire."</p> <p>To avoid issue of meeting specific measurements, Corrosion Control SMR team removed specifying minimum distance away from the pipe an anode should be placed. They felt the size of the excavation would detect the placement of the anode was more realistic.</p> <p>1. F.: Simplified instructions on activating anode(s) to be consistent with CORR 1 language. "If the pipe to soil reading does not change after installation of anode(s), add water to activate."</p> <p>Corrosion SMR group felt there needed to be additional instructions added to ensure that anodes were being correctly in-</p>	Octo- ber 1, 2011	July 1, 2014

stalled and to reinforce the necessity of the anode being activated after installation.

4. Anode Requirements

4. B.: Service lines and repairs steel main and services, install anodes as shown in table.

Changed the Pipe to Soil reading criteria to -0.900 VDC from -1.000 VDC to be consistent throughout the O&M.

Revised the instructions if the P/S reading is less negative than -0.900 VDC. Install an anode as long as it is not a transmission main.

In the table headings added examples as to what is a more negative reading and a less negative reading.

Corrosion Control SMR team felt the logical course of action would be to install an anode rather than contacting a corrosion control person, who in most cases advise installing an anode when it is not a transmission main. Example of a more negative and a less negative reading was added to provide clarification and eliminate confusion.

4. D.: Isolated services, install anodes as shown in table.

Changed the Pipe to Soil reading criteria to -0.900 VDC from -1.000 VDC to be consistent throughout the O&M.

Revised the instructions if the P/S reading is less negative than -0.900 VDC on an existing isolated service line to go ahead and install an anode.

Corrosion SMR group agreed the Pipe to Soil reading threshold should be the same throughout the O&M. Corrosion Control SMR team felt the logical course of action would be to install an anode rather than contacting a corrosion control person, who in most cases advise installing an anode.

5. Anode Bank Installation

5. C.: Added a reference to CORR 3.04 Perpendicular Anode Bank and to CORR 3.03 Parallel Anode Bank.

5. E.: Added a reference to CORR 3.14 Test Lead Wire Attachment for instruction on attaching collector wire to the main and coating the connection.

Links to the Corrosion Standards were added as an improvement to the O&M.

CORR
2.03

Coatings

5. Approved Cold Applied Wax Tapes

5. D.: Trenton Items - Added Trenton Fill-Pro PM-GP as an approved profiling mastic to be used on irregular surfaces to create a smooth surface prior to applying wax tape.

January 1,
2014

July 1,
2014

Based on field trials, Corrosion Control found the Trenton Fill-Pro to be more moldable than the Trenton Profiling Material and easier to fill in irregular surfaces.

CORR 2.16	<p>Measuring Cathodic Protection Potentials</p> <p>4. Equipment</p> <p>4. B. Copper Sulfate Reference Electrode</p> <p>4. B.(6)(b): Revised language regarding cleaning and refilling the Reference Electrode based on information provided by a manufacturer.</p> <p>(6) Maintenance</p> <p>(6)(b): After prolonged use, the copper sulfate solution may become contaminated, which causes measurement errors.</p> <ul style="list-style-type: none"> · Half-cells used sporadically throughout the year should be cleaned and refilled annually. · Half-cells used daily should be cleaned and refilled quarterly or when needed. · The copper sulfate solution may become cloudy with use. This does not mean the solution has become seriously contaminated. <p>(6)(c) & (6)(d) have been deleted</p> <p>Corrosion SMR group felt the current language regarding maintenance of the half cells was too difficult to follow and the manufacturer's recommendations were straight forward and easier to understand and follow.</p>	Janu- ary 1, 2013	July 1, 2014
CORR 2.29	<p>Records</p> <p>2. Construction Order Review Process</p> <p>2. A. General</p> <p>2. A.(3): Grammatical only, updated job titles: Field Engineering Representatives, and Gas Tech Engineering</p> <p>2. B. Belleville Design Center/Peoria Design Center</p> <p>2. B.(2): Revise work group to "Gas Engineering Work (Work designed by Gas Tech Engineering or Consultant)</p> <p>2. B.(2)(b): Revised language in the Corrosion Technician review of final design to state the review will be documented on the Cathodic Protection Review stamp. A revised Cathodic Protection Review stamp has been added.</p> <p>2. B.(2)(c): In Post Construction - As Builts section changed "Designer" to "DDC/PDC Poster". Posters will give copy of "as built" to the Corrosion Tech if field changes are made.</p> <p>2. B.(2)(c): Added PDC. "Corrosion Technician will send mapping changes to the DDC/PDC for posting as needed."</p>	Janu- ary 1, 2013	July 1, 2014

Revisions were made to reflect current position titles and updated review process by Corrosion Techs,

CORR
2.30

Buried Pipe Examination
2. Buried Pipe Examination

April
1,
2013

July 1,
2014

2. F.: Added the word "section" to the sentence, "A Buried Pipe Examination form is not required on the new pipe being installed or when an existing section of pipe is planned to be retired and will not remain in service.

2. G. (5): Merely a format change by dividing earlier language into bullet points.

2. H.: Inserted a new item: The internal surface of the abandoned pipe must be inspected for evidence of corrosion as stated in CORR 1. A corrosion control person for the area should be notified if there is an indication of internal corrosion. Any internal corrosion found will be documented on a Corrosion and Steel Damage Evaluation, CORR 2.31, stating where the internal corrosion was found; on the pipe remaining in service or the abandoned pipe.

Note: If a corrosion control person or qualified gas engineer is not available at time of discovery, a representative section of the pipe with internal corrosion can be removed and retained for evaluation.

This was added as an emphasis that an internal inspection for evidence of atmospheric corrosion is required, by Part 192 Code, for any steel pipe being removed from service for any reason. If evidence is found then a Corrosion and Steel Damage Evaluation is required to document the internal inspection.

5. Completion Instructions

5, C. Steel Pipe Information

5. C. 20.: Revised the wording by eliminating the language regarding Corrosion Control monitoring PEET database.

20. Pipe to Soil Reading: Required - Select Not Required or select P/S and enter the pipe to soil reading. Pipe to Soil readings are not required if bare steel is not exposed, coating is not removed, or if the exam is on a rectifier-protected pipe and the rectifier is turned off. If a magnesium anode is installed, record the anode installation in the Remarks section of the form or on the job order created for the anode installation. Do not install galvanic anodes on transmission pipelines unless recommended by Corrosion Control Personnel.

Corrosion Control SMR team removed the PEET monitoring language since it had no bearing on how to complete the Buried Pipe Examination form.

CORR 3.01	<p>Anode Installation - Direct Connection</p> <p>Additional installation procedures have been added by the Corrosion SMR team to ensure anodes are being correctly installed.</p> <p>Inserted new: "3. Anode can be placed vertically or horizontally and a minimum of six (6) inches below the bottom of the steel pipe. Anodes may be installed in multiple groupings. No more than 2 anodes shall be installed in an excavation unless 10 feet of spacing can be maintained between the anodes. If multiple connections are made on the pipe, the connections should be at least six (6) inches apart.</p> <p>4.: "Anode should be placed as far away from the pipe as the excavation safely allows up to the length of the anode lead wire."</p> <p>Revised language: "6. If the Pipe to Soil reading does not change after installation of anode(s), add water to activate. See CORR 2.02."</p> <p>Added to 8: "Do not attach wire within two (2) inches of longitudinal seam or nearest girth weld."</p> <p>Added Reference to CORR 3.14: "10. Attach wire, as described in CORR 3.14, to clean (no coating, grease, moisture, dirt, or rust) pipe after looping wire around pipe as shown.</p> <p>Inserted New: "11. Steel pipe operating at or below 60 psig, a welded 5/16" bolt may be used to attach test lead to the pipe as shown in CORR 3.14."</p>	Febru- ary 1, 2010	July 1, 2014
CORR 3.02	<p>Anode Test Station</p> <p>Additional installation procedures have been added by the Corrosion SMR team to ensure anodes and test stations are being correctly installed. Language is basically a repeat of CORR 3.01.</p> <p>Inserted new: "3. Anode can be placed vertically or horizontally and a minimum of six (6) inches below the bottom of the steel pipe. Anodes may be installed in multiple groupings. No more than 2 anodes shall be installed in an excavation unless 10 feet of spacing can be maintained between the anodes. If multiple connections are made on the pipe, the connections should be at least six (6) inches apart.</p> <p>4.: "Anode should be placed as far away from the pipe as the excavation safely allows up to the length of the anode lead wire."</p> <p>Revised language: "6. If the Pipe to Soil reading does not change after installation of anode(s), add water to activate. See CORR 2.02."</p> <p>Added to 8.; "Do not attach wire within two (2) inches of longitudinal seam or girth weld."</p>	Febru- ary 1, 2010	July 1, 2014

Added Reference to CORR 3.14: "10. Attach wire, as described in CORR 3.14, to clean (no coating, grease, moisture, dirt, or rust) pipe after looping wire around pipe as shown.

Inserted new: "11. Steel pipe operating at or below 60 psig, a welded 5/16" bolt may be used to attach test lead to the pipe as shown in CORR 3.14."

Material List:

Updated the description of the CP Test Box to reflect a change in buried test boxes now being stocked in the storerooms. "Box, CP Test, 4 in ID x 18 in Lgh, Plastic w/Cast Iron Lockable Lid, 5 terminals, Marked Gas Test."

CORR
3.03

Parallel Anode Bank

February 1,
2010

July 1,
2014

Corrosion SMR team significantly expanded the installation instructions to ensure for proper installation. The following procedures were added or expanded.

Inserted new: "2. Install anode in convenient location, as near as practical to that shown on construction drawing, and record installation. See CORR 2.02"

Inserted new: "3. Anode can be placed vertically or horizontally and a minimum of six (6) inches below the bottom of the steel pipe. See CORR 2.02"

Inserted new: "4. Carefully lower or place anode in the hole or excavation and center it. Do not lower anode using lead wire."

Revision: 5. Specified a #8 split bolt and added the stock code 17 54 002 for the split bolt.

Inserted new: "7. If Pipe to Soil readings do not change after installation of anode(s), add water to activate. See CORR 2.02"

Inserted new: "8. Backfill with fine earth (not sandy or rocky soil) around anode to about 4" above top of bag. Complete backfill with tamped earth."

Inserted new: "9. Leave sufficient slack in wire to avoid damage when back-filling."

Inserted new: "10. Attach wire, as described in CORR 3.14, to clean (no coating, grease, moisture, dirt, or rust) pipe. Do not attach wire within two (2) inches of longitudinal seam or nearest girth weld."

Inserted new: "11. Coat connection according to the methods described in CORR 3.14."

Material List:

Updated the description of the CP Test Box to reflect a change in buried test boxes now being stocked in the storerooms. "Box, CP Test, 4 in ID x 18 in Lgh, Plastic w/Cast Iron Lockable Lid, 5 terminals, Marked Gas Test."

UNCONTROLLED IF PRINTED

Added the Splice box, 49 62 001, as an option to the vinyl tape at the instructions from the Corrosion SMR team.

CORR 3.04	<p>Perpendicular Anode Bank</p> <p>Corrosion SMR team significantly expanded the installation instructions to ensure for proper installation. The following procedures were added or expanded.</p> <p>Inserted new: "2. Install anode in convenient location, as near as practical to that shown on construction drawing, and record installation. See CORR 2.02"</p> <p>Inserted new: "3. Anode can be placed vertically or horizontally and a minimum of six (6) inches below the bottom of the steel pipe. See CORR 2.02"</p> <p>Inserted new: "4. Carefully lower or place anode in the hole or excavation and center it. Do not lower anode using lead wire."</p> <p>Revised: 5. Specified a #8 split bolt and added the stock code 17 54 002 for the split bolt.</p> <p>Inserted new: "7. If Pipe to Soil readings do not change after installation of anode(s), add water to activate. See CORR 2.02"</p> <p>Inserted new: "8. Backfill with fine earth (not sandy or rocky soil) around anode to about 4" above top of bag. Complete backfill with tamped earth."</p> <p>Inserted new: "9. Leave sufficient slack in wire to avoid damage when back-filling."</p> <p>Inserted new: "10. Attach wire, as described in CORR 3.14, to clean (no coating, grease, moisture, dirt, or rust) pipe. Do not attach wire within two (2) inches of longitudinal seam or nearest girth weld."</p> <p>Inserted new: "11. Coat connection according to the methods described in CORR 3.14."</p> <p>Material List:</p> <p>Updated the description of the CP Test Box to reflect a change in buried test boxes now being stocked in the storerooms. "Box, CP Test, 4 in ID x 18 in Lgh, Plastic w/Cast Iron Lockable Lid, 5 terminals, Marked Gas Test."</p> <p>Added the Splice box, 49 62 001, as an option to the vinyl tape at the instructions from the Corrosion SMR team.</p>	February 1, 2010	July 1, 2014
CORR 3.05	<p>Drive-In Anode</p> <p>Additional installation procedures have been added by the Corrosion SMR team to ensure drive-in anodes are being correctly installed.</p> <p>Inserted new: "5. A grounding clamp can be used in place of the clamp that comes with the drive-in anode. The riser will</p>	February 1, 2010	July 1, 2014

have to be cleaned down to bare metal where the grounding clamp makes contact.

Grounding clamp for 1/2" and 1" risers is Stock Code 40 59 319

Grounding clamp for 1-1/4" and 2" risers is Stock Code 40 59 318"

Revised 7. To require applying only one layer of was tape, over the wire. Deleted applying two layers of wax tape, one under the anode wire and one over the anode wire.

Revised 9. "Typically place anode approximately 12 inches to 18 inches from the riser and drive with hammer until head is below grade."

Inserted new: "10. If the Pipe to Soil reading does not change after installation of anode, add water to activate. See CORR 2.02

CORR 3.06	<p>Anode Installation - Isolated Steel Service Line</p> <p>Additional installation procedures have been added by the Corrosion SMR team to ensure anodes are being correctly installed.</p> <p>Inserted new: "5. Attach wire, as described in CORR 3.14, to clean (no coating, grease, moisture, dirt, or rust) pipe.</p> <p>Inserted new: "7. If Pipe to Soil reading does not change after installation of anode, add water to activate. See CORR 2.02</p>	February 1, 2010	July 1, 2014
CORR 3.07	<p>Single Test Lead - Flush Grade Test Station</p> <p>Additional installation procedures have been added by the Corrosion SMR team to ensure test lead is being correctly installed.</p> <p>Inserted new: "2. Attach wire, as described in CORR 3.14, to clean (no coating, grease, moisture, dirt, or rust) pipe after looping wire around pipe as shown. Do not attach wire within two (2) inches of longitudinal seam or nearest girth weld".</p> <p>Inserted new: "3. Steel pipe operating at or below 60 psig, a welded 5/16" bolt may be used to attach test lead to the pipe. See CORR 3.14 for material list."</p> <p>Inserted new: "6. Terminate the test lead wire on a terminal in the test station."</p> <p>Material List</p> <p>Updated the description of the CP Test Box to reflect a change in buried test boxes now being stocked in the storerooms. "Box, CP Test, 4 in ID x 18 in Lgh, Plastic w/Cast Iron Lockable Lid, 5 terminals, Marked Gas Test."</p>	February 1, 2010	July 1, 2014

CORR 3.08	<p>Single Test Lead - Above Grade Test Station</p> <p>Additional installation procedures have been added by the Corrosion SMR team to ensure test lead is being correctly installed.</p> <p>Inserted new: "3. Attach wire, as described in CORR 3.14, to clean (no coating, grease, moisture, dirt, or rust) pipe after looping wire around pipe as shown. Do not attach wire within two (2) inches of longitudinal seam or nearest girth weld."</p> <p>Inserted new: "4. Steel pipe operating at or below 60 psig, a welded 5/16" bolt may be used to attach test lead to the pipe as shown in CORR 3.14."</p> <p>Inserted new: "7. Terminate the test wire on a terminal in the test station."</p>	February 1, 2010	July 1, 2014
CORR 3.09	<p>Foreign Pipeline Crossing Test Station</p> <p>Corrosion SMR group added the following to ensure test stations were being properly installed.</p> <p>Inserted new: "3. Attach wires, as described in CORR 3.14, to clean (no coating, grease, moisture, dirt, or rust) Ameren Illinois pipe after looping wires around pipe as shown. Do not attach wires within two (2) inches of longitudinal seam or nearest girth weld. Multiple connections to the pipe should be at least six (6) inches apart."</p> <p>Revised: "5. Terminate test wires on terminals in the test station." Deleted "as shown in construction drawing or neatly in test station."</p>	February 1, 2010	July 1, 2014
CORR 3.10	<p>Inline Insulator - Above Grade Test Station</p> <p>Corrosion SMR group added the following to ensure test stations were being properly installed.</p> <p>Inserted new: "1. Attach wire, as described in CORR 3.14, to cleaned (no coating, grease, moisture, dirt, or rust) pipe after looping wire around pipe as shown. Do not attach wire within two (2) inches of longitudinal seam or nearest girth weld."</p> <p>Inserted new: "2. Steel pipe operating at or below 60 psig, a welded 5/16" bolt may be used to attach test lead to the pipe as shown in CORR 3.14."</p> <p>Inserted new: "6. Terminate the test lead wire on a terminal in the test station."</p>	February 1, 2010	July 1, 2014
CORR 3.11	<p>Inline Insulator - Flush to Grade Test Station</p> <p>Corrosion SMR group added the following to ensure test stations were being properly installed.</p> <p>Inserted new: "1. Attach wire, as described in CORR 3.14, to clean (no coating, grease, moisture, dirt, or rust) pipe after</p>	February 1, 2010	July 1, 2014

looping wire around pipe as shown. Do not attach wire within two (2) inches of a longitudinal seam or nearest girth weld"

Inserted new: "2. Steel pipe operating at or below 60 psig, a welded 5/16" bolt may be used to attach test lead to the pipe as shown in CORR 3.14."

Revised "5. Terminate the test wires on the terminals in the test station." Deleted "as shown in construction drawing or neatly in test station."

Material List

Updated the description of the CP Test Box to reflect a change in buried test boxes now being stocked in the storerooms. "Box, CP Test, 4 in ID x 18 in Lgh, Plastic w/Cast Iron Lockable Lid, 5 terminals, Marked Gas Test."

CORR 3.12	<p>Insulated Valve - Underground</p> <p>Corrosion SMR group added the following to ensure test station in a valve box was being properly installed.</p> <p>Inserted new: "1. Attach wire, as described in CORR 3.14, to cleaned (no coating, grease, moisture, dirt, or rust) pipe after looping wire around pipe as shown. Do not attach wire within two (2) inches of a longitudinal seam or nearest girth weld."</p> <p>Inserted new: "2. Steel pipe operating at or below 60 psig, a welded 5/16" bolt may be used to attach test lead to the pipe as shown in CORR 3.14."</p>	February 1, 2010	July 1, 2014
CORR 3.13	<p>Flange Fink Station</p> <p>Corrosion SMR added instructions on attaching wires to the pipe or to the edge of the flanges.</p> <p>Test Leads Attached to Pipe:</p> <p>Added installation instructions:</p> <p>Installation</p> <p>"1. Attach wire, as described in CORR 3.14, to clean (no coating, grease, moisture, dirt, or rust) pipe after looping wire around pipe as shown. Do not attach wire within two (2) inches of a longitudinal seam or nearest girth weld."</p> <p>"2. Steel pipe operating at or below 60 psig, a welded 5/16" bolt may be used to attach test lead to the pipe as shown in CORR 3.14."</p> <p>"3. Coat each connection according to the methods described in CORR 3.14".</p> <p>"4. Terminate the test leads on the terminals in the test station."</p> <p>Test Leads Attached to Flanges:</p> <p>Installation</p>	April 1, 2012	July 1, 2014

"1. Attach wire to the outside edge of the flanges with either thermite weld or welded 5/16" bolt as described in CORR 3.14. A 5/16" bolt can be welded on the edge of flange that is operating at any pressure."

"2. Cover or protect the flange gasket from slag resulting from either the thermite weld or welding on a bolt."

"3. Coat each connection according to the methods described in CORR 3.14."

"4. Terminate the test leads on the terminals in the test station."

Material List

Added stock codes for the material necessary to install 5/16" bolt.

CORR
3.14

Test Lead Wire Attachment

Corrosion SMR group added these to provide more guidance on attaching test leads to pipe.

October 1,
2011

July 1,
2014

1. D.: New: "If multiple connections are made on the pipe, the connections should be at least six (6) inches apart.

1. E.: New: "Do not attach wire within two (2) inches of longitudinal seam or nearest girth weld."

2. Cadweld Thermite Welding Process

2. A. Installation

2. A.(1): Moved checking atmosphere for the presence of natural gas up to the first thing that should be done before proceeding.

Ensuring the work location is gas free is the first priority before beginning any work.

2. A.(4): Expanded instructions on pipe preparation: "Use a file, wire wheel, scraper, power brushes or grinder, or commercial blasting on the pipe until the bare metal is bright and shiny in the attachment location. If commercial blasting is used clean the grit or shot off the pipe after blasting."

2. A.(5): Added "dry pipe" in addition to cleaning the pipe thoroughly before starting the weld.

2. A.(6): Added precautionary language when using a torch to heat the pipe prior to thermit weld.

(a) "Be cautious not to damage the existing pipe coating during this step by keeping the torch moving."

(b) "If there is PE pipe is connected to the steel pipe, keep the torch flame away from the PE pipe or protect the PE pipe from the torch flame. Protection methods can be such as; covering PE pipe with backfill material, covering with noncombustible material, or placing a shield between the torch and PE Pipe, etc."

2. A.(10): Inserted a new item: "Place metal disk in mold prior to pouring in powder."

3. Cadweld Plus Process

3. A. Installation

The same revisions were made to the Cadweld Plus Process that was added to the Cadweld Thermit Welding Process.

3. A.(4): Expanded instructions on pipe preparation: "Use a file, wire wheel, scraper, power brushes or grinder, or commercial blasting on the pipe until the bare metal is bright and shiny in the attachment location. If commercial blasting is used clean the grit or shot off the pipe after blasting."

3. A.(5): Added "dry pipe" in addition to cleaning the pipe thoroughly before starting the weld.

3. A.(6): Added precautionary language when using a torch to heat the pipe prior to thermit weld.

(a) "Be cautious not to damage the existing pipe coating during this step by keeping the torch moving."

(b) "If there is PE pipe is connected to the steel pipe, keep the torch flame away from the PE pipe or protect the PE pipe from the torch flame. Protection methods can be such as; covering PE pipe with backfill material, covering with noncombustible material, or placing a shield between the torch and PE Pipe, etc."

6. Test Lead Attachment Coating

6. B. Handy Cap (19 62 336)

The instructions for using the Handy Cap have been significantly expanded to follow manufacturer's instructions for; Installation, Inspection and Testing and Backfilling.

6. B.(1) Installation:

6. B.(2) Inspection and Testing

6. B.(3) Backfilling

CORR
3.15

Rectifier Installation

3. Rectifier Ground Bed Anode Installation

3. B.(2): Added "Loose coke breeze is an optional backfill material."

4. Rectifier Ground Bed Header Connections

4. B.(1) Description for Dryconn Visilock:

4. B.(1)(d), (e), (g), (i): Deleted these previous instructions to be consistent with manufacturer's procedures.

5. Connection of Rectifier Lead to Transmission Main

5. B.: Installation

January 1,
2014

July 1,
2014

5. B.(2): Inserted new "The connections should be at least six (6) inches apart."

Corrosion SMR group added the loose coke breeze as an optional backfill material for the anode bed and cleaned up the installation instruction.

EMER 0	Table of Contents Added EMER 2.11 Gas Control	Janu- ary 1, 2014	July 1, 2014
EMER 2.04	Gas Field Personnel 4. Major Leaks or Line Breaks 4. H.: Corrected reference EMER 2.04 10. Loss and Restoration of Service. January version had 2.04 9. 10. Loss and Restoration of Service 10. E: Revision made to how customer list can be obtained. Added Contacting Gas Engineer, DDC/PDC, or Gas Tech Engineering, who can assist in obtain a list. After checking with Operations, some areas are going through the DDC/PDC or Gas Tech Engineering- Planning group to acquire a customer list instead of using the Gas Emergency Re-light User's Guide.	Janu- ary 1, 2014	July 1, 2014
EMER 2.05	Natural Disasters or Civil Disobedience 2. Natural Disasters 2. H.: Updated position title, Manager, Gas Compliance & Training, who Gas Supervisor is to notify and kept updated on situation. 3. Floods 3. C. Following the Flood 3. C.(6): Inserted a new item, "Create pipeline patrols in the Gas Compliance System for any pipeline segments that become exposed, undermined, or at risk due to reduced cover. See PTRL 1. This item was added in response to a Notice of Amendment issued by the ICC. Additional measures needed to be added to address inspection of pipelines subjected to flooding. Additional procedures are also contained in PTRL 1 and PTRL 2.02 - Critical Area Patrols.	April 1, 2013	July 1, 2014
EMER 2.11	New: Gas Control New section was added to provide general information regarding Gas Control's interaction with gas operating personnel. Gas Control remotely monitors numerous gas facilities and operations. This section addresses steps taken when Gas Control: a) loses communications with devices they are remotely	N/A	July 1, 2014

monitoring and b) responses to alarms indicating possible abnormal operation, malfunction of a component or safety device.

These procedures were added in response to a Notice of Amendment issued by the ICC which requested information contained in Gas Controls' Control Room Management Plan regarding response to abnormal operations be included in the Gas O&M Plan.

MAIN 3.15	<p>End of Main Extension Steel to PE, Mueller Stopper</p> <p>Stock Code for the 4 inch Line Stopper updated to match what GTECH construction units, 19 23 148 for the thin wall fittings.</p> <p>DDC representative sent a message that Construction Unit in GTECH for the 4 inch Class 150 Mueller Line Stopper did not match what is in the O&M Main Standards. All of the following Standards have the same correction,</p>	January 1, 2011	July 1, 2014
MAIN 3.16	<p>End of Main Extension Steel to PE, Increasing, Mueller Stopper</p> <p>Stock Code for the 4 inch Line Stopper updated to match what GTECH construction units, 19 23 148 for the thin wall fittings.</p>	January 1, 2011	July 1, 2014
MAIN 3.17	<p>End of Main Extension Steel to PE, Decreasing, Mueller Stopper</p> <p>Stock Code for the 4 inch Line Stopper updated to match what GTECH construction units, 19 23 148 for the thin wall fittings.</p>	January 1, 2011	July 1, 2014
MAIN 3.21	<p>End of Main Extension Steel to Steel, Mueller Stopper</p> <p>Stock Code for the 4 inch Line Stopper updated to match what GTECH construction units, 19 23 148 for the thin wall fittings.</p>	January 1, 2011	July 1, 2014
MAIN 3.22	<p>End of Main Extension Steel to Steel, Increasing, Mueller Stopper</p> <p>Stock Code for the 4 inch Line Stopper updated to match what GTECH construction units, 19 23 148 for the thin wall fittings.</p>	January 1, 2011	July 1, 2014
MAIN 3.23	<p>End of Main Extension Steel to Steel, Decreasing, Mueller Stopper</p> <p>Stock Code for the 4 inch Line Stopper updated to match what GTECH construction units, 19 23 148 for the thin wall fittings</p>	January 1, 2011	July 1, 2014
METR 2.25	<p>Ultrasonic Meter Testing</p> <p>1. General</p> <p>1. A.: Grammatical changes; replaced "vendor" with "manufacturer's" and replaced "validate measurement accuracy" with "verify proper meter operation"</p>	January 1, 2012	July 1, 2014

1. B.: Clarification that the "AGA 9 specifications" is "AGA Report No. 9 specifications"

2. Ultrasonic Meter Inspection Schedule

2. A.: Changed the inspection interval from "twice each calendar year" to "once every 3 months."

2. B.: Completely revised to: "With gas flowing through the meter, use the manufacturer's software to create a maintenance report that captures at least two minutes of data. The software uses the captured data to generate reports and graphs detailing the ultrasonic transducer performance as well as the overall meter performance. Save the reports to document the current meter condition and also to develop diagnostic benchmarks."

2. E.: Removed "confirm Gas Control is using the same meter factor as USM." Now only the on-site flow computer meter factor is confirmed to be the same as USM.

5. Inspection Records

This section was totally revised to reflect utilizing electronic records.

A. Complete and save electronic versions of the Ameren Illinois Gas Instrument Calibration Data Sheets for the pressure and temperature transmitters associated with the meter.

B. Save electronic copies of the manufacture's software generated maintenance and/or inspection reports as well as software generated meter configuration files. Save maintenance log and meter configuration files then print a copy of the current meter configuration (or parameter list).

C. Send electronic copies of items A and B to the Gas Meter Engineer - Decatur Central Meter Shop.

D. All meter configuration files, calibration, inspection, and maintenance information shall be maintained on the USM SharePoint site or as a paper record.

Metering SMR team revised this entire section to make it consistent with current processes.

METR
3.01

New Meter Sizing

3. Approved Meters for New Installations

Minor correction made in the capacity table for:

Roots 15C/175 metering pressure of 2 psig - 1670cfh from 1680

Roots 3/3.5M175 metering pressure of 2 psig - 3340cfh from 3370

Roots 5/5.5M175 metering pressure of 2 psig - 5570cfh from 5590

January 1,
2013

July 1,
2014

Roots 7M175 metering pressure of 7"wc - 7000cfh from 6300 and metering pressure of 2 psig - 7790cfh from 7810

METR 3.02	Existing Meter Sizing 4. Existing Rotary Meter Installations Corrections made in the capacity table for the Roots 5M thru 102M with metering pressure of 7"wc and 2 psig. Capacities for the 7"wc metering pressure were corrected to match manufacturer's rated capacities. Capacities for the 2 psig metering pressure were adjusted slightly.	January 1, 2013	July 1, 2014
METR 3.04	Regulator Sizing - 2 psig Delivery Pressure 2" Fisher 299H, 1/2" orifice: Updated the foot note for all pressures to (4) which requires a 2" Fisher 289H relief valve for all pressures.	April 1, 2013	July 1, 2014
POLY 0	Table of Contents Added: POLY 2.09 Plastic Fusion Qualification Added: FORMS Plastic Fusion & Joining Annual Qualification Reference Materials Removed Central Electrofusion Installation Procedural Manual Added: Central MSA 340 Processor Operation Manual Genesis F3Processor Operator Guide Phoenix Battery Processor Model 804 McElroy Pit Bull Hydraulic Machines	April 1, 2013	July 1, 2014
POLY 1	9. Tracer Wire: 9. A.: Revised to include a table with the stock codes for: #12 Solid Soft Drawn Copper and #10 Stainless Steel Stranded tracer wire. Gas Standards Committee approved the use of stainless steel tracer wire particular for long or difficult directional bores where breakage of copper tracer wire could be anticipated. The stainless steel wire is much stronger than the copper. 9. E.: Added consideration could be given to using stainless steel tracer wire for long or difficult directional bores. "If stainless steel wire is used, a test station should be brought up at the location where the stainless joins to the copper wire with a lead running to each wire. The copper and stainless wires should not be directly tied together. See Bore 2.03" 9. G.: Added a table with the stock codes for the split bolt connectors and splice box.	January 1, 2014	July 1, 2014

Corrosion Control group wants to make sure the stainless steel tracer wire and the copper tracer wire are not connected due to dissimilar metals. A test box should be used to terminate the ends for the wire that way there would be continuity for locating purposes.

9. H.: Added a reference to CORR 2.03 for approved coating when attaching tracer wire to steel risers, mains, or services.

Reference added as an enhancement.

POLY 2.09	<p>New: Plastic Fusion Qualifications</p> <p>This new section identifies what is included in Ameren Illinois' plastic fusion qualification, testing and requalification program.</p> <p>This was added to comply with Part 192.285 for qualifying PE pipe joining procedures. Gas Training group prepared these procedures in response to a Notice of Amendment issued by the ICC.</p>	N/A	July 1, 2014
POLY 4	<p>Forms and Reference Materials</p> <p>Added Form 01 - Plastic Fusion & Joining Annual Qualification</p> <p>Reference Materials:</p> <p>Removed Central Electrofusion Installation Procedural Manual</p> <p>Central's manual was removed because it had some different procedures than are in POLY 2.05. POLY 2.05 contains the official electrofusion procedures.</p> <p>Added:</p> <p>Reference 19 - Central MSA 340 Processor Operation Manual</p> <p>Reference 20 - Genesis F3 Processor Operator Guide</p> <p>Reference 21 - Phoenix Battery Processor Model 804</p> <p>Reference 22 - McElroy Pit Bull Hydraulic Machines</p>	April 1, 2013	July 1, 2014
PTRL 1	<p>1. A.: Simple word change, Ameren Illinois replaces Operators</p> <p>2. Frequency of Transmission Patrols</p> <p>Added Note: "Ameren Illinois does not have any Class 4 locations within its operating areas."</p> <p>3. Frequency of Distribution Patrols</p> <p>3. A.: Added a reference link to PTRL 2.02 which defines Critical Area Patrols.</p> <p>Reference to PTRL 2.02 was added to the Critical Area Patrol document that specifies the frequency of patrols. This was done in response to an ICC NOA.</p>	July 1, 2012	July 1, 2014

<p>PTRL 2.01</p>	<p>Transmission Patrols</p> <p>2. Transmission Main Patrols</p> <p>2. B.: Added Note under table: "Ameren Illinois does not have any Class 4 locations within its operating areas."</p> <p>3. Patrol Requirements</p> <p>3. B.: Inserted new item: "Inaccessible segments of transmission line due to flooding, vegetation, difficult terrain, etc.</p> <p>Note: If the completion of the transmission patrol will be delayed beyond the compliance date due to inaccessibility, Gas Compliance should be notified in advance of the compliance date for special consideration of the missed compliance date."</p> <p>Inaccessible to sections of transmission lines are still required to be patrol in order to complete the patrol in GCS, Supervisors must be made aware of these locations in order communicate with Gas Compliance the possibility of not getting the patrol completed by the compliance date.</p> <p>3. C.(3): Added reference to pipeline marker standards; PTRL 3.01, PTRL 3.02, or PTRL 3.04</p> <p>4. Processing Data</p> <p>4. A.: Grammatical: Added "Tech" to "Gas Tech Engineering".</p>	<p>April 1, 2012</p>	<p>July 1, 2014</p>
<p>PTRL 2.02</p>	<p>Critical Area Patrols</p> <p>1. General</p> <p>1. A.: Revise the wording to now state: "This section outlines critical areas along distribution mains that are require to be patrolled to ensure conditions have not deteriorated, putting the gas facilities in danger of damage or leakage and the consequent hazards to public safety." Replaced "special attention" with "to be patrolled". Added "and the consequent hazards to public safety" at the end of the sentence.</p> <p>1. B.: This is former 4. Patrol Requirements language 2. Critical Areas:</p> <p>2.Critical Areas</p> <p>2. F.: New - "Mains identified as exposed or undermined after periods of heavy rains or flooding."</p> <p>4. Processing Data</p> <p>4. A.: Added "patrol" to identify the inspection report used as documentation.</p> <p>4. B.: Revised to state "Notify Gas Supervisor of any change in conditions where follow-up action is required." Added "of any change in conditions" and replaced "may be" with "is".</p> <p>These items were added under Critical Areas in response to a Notice of Amendment issued by the ICC. Additional measures</p>	<p>January 1, 2012</p>	<p>July 1, 2014</p>

needed to be added to address inspection of pipelines subjected to flooding.

PTRL 2.03	<p>Patrol Methods</p> <p>2. Foot Patrol</p> <p>2. A.(5): Inserted new item: "Agricultural field tiling operations in vicinity of the pipeline."</p> <p>2. A.(6): Simply word change, Ameren Illinois replaces operator. Added reference to pipeline marker standards, PTRL 3.01, PTRL 3.02, and PTRL 3.04.</p> <p>3. Vehicular Patrol</p> <p>3. A.(5): Inserted new item: "Agricultural field tiling operations in vicinity of the pipeline."</p> <p>3. A.(6): Simply word change, Ameren Illinois replaces operator. Added reference to pipeline marker standards, PTRL 3.01, PTRL 3.02, and PTRL 3.04.</p> <p>4. Aerial Patrol</p> <p>4. A.(3): Inserted new item: "Agricultural field tiling operations in vicinity of the pipeline."</p> <p>4. A.(5): Deleted the sentence, "These should be reported to the Gas Supervisor for follow up investigation by foot patrol." This duplicated language that is in 4. B.</p> <p>SMR Team felt that field tiling operations should be another item personnel performing a patrol should be observant of since it is common for transmission lines to lay under agricultural land,</p>	October 1, 2011	July 1, 2014
PTST 0	<p>Added new section</p> <p>PTST 2.05 MAOP Determination</p> <p>Forms:</p> <p>Updated Form 01 - Gas Leak & Strength Test Stamp</p> <p>Added Form 02 - Leak & Strength Test Record</p>	April 1, 2013	July 1, 2014
PTST 2.05	<p>New Section: MAOP Determination</p> <p>1. General</p> <p>The purpose of this procedure is to outline determination methods for establishing maximum allowable operating pressure (MAOP) on gas pipeline facilities owned and operated by Ameren Illinois.</p> <p>2. MAOP Determination</p> <p>3. MAOP for Steel or Plastic Pipelines</p> <p>4. Alternative MAOP for Certain Pipelines</p>	N/A	July 1, 2014

- 5. MAOP High Pressure Distribution Systems
- 6. MAOP Low Pressure Systems
- 7. Records

PTST 2.05 added to provide procedures used to determine MAOP for Ameren Illinois' gas facilities. This section was added to comply with Part 192.619, 192.620, 192.621, and 192.623 in response to a Notice of Amendment issued by the ICC.

PTST 4	Forms and Reference Materials Forms: Updated Form 01 - Gas Leak & Strength Test Stamp Added Form 02 - Leak & Strength Test Record Form 01 Gas Leak & Strength Test Stamp is the one used by the Distribution Design Center for facilities with MAOP of 60 psig or less. Two previous stamps have been combined into one test stamp. Form 02 Leak & Strength Test Record is used for projects designed by Gas Tech Engineering and normally used for facilities with MAOP greater than 60 psig	April 1, 2013	July 1, 2014
REPR 1	1. F.: Updated to require contacting Gas Tech Engineering before repairing any high pressure distribution, MAOP over 60 psig, and transmission piping. The change from 100 psig to 60 psig to be consistent with the other sections in O&M. Gas Tech Engineering is responsible for gas facilities with MAOP over 60 psig. 4. Steel Pipe Repair Methods 4. L.: New section added Encapsulation which allows for the use of: Approved manufactured fittings such as Mueller or TDW line stoppers, short stops, save-a-valve nipple or steel pipe with welded cap or Reinforcing saddles for encapsulating leaking service tees, tapered screw plugs, etc. Members of the SMR team indicated this has been a practice in their areas for years and felt it needed to be added to the O&M. In many cases, being able to encapsulate a leaking fitting eliminates the need to isolate a section of main by installing line stopper fittings.	Janu- ary 1, 2014	July 1, 2014
RNST 2.01	Reinstating Mains and Services 3. Reconnecting of Temporarily Disconnected Farm Tap Services 3. B.(2): Inserted new: "When the downstream (second cut) regulator is removed from a farm tap with two stage pressure reduction, the outlet piping from the downstream (second cut)	July 1, 2012	July 1, 2014

regulator to the meter valve shall be pressure tested at 90 psig for a minimum duration as specified in PTST 2.01."

3. B.(3): Revised wording: "When the upstream (first cut) regulator is removal from farm tap with two-stage pressure reduction, piping between the first cut regulator and inlet to the second cut regulator shall be tested as described in PTST 1."

SMR personnel felt this revision was necessary to clarify the difference testing requirements depending on which regulator is removed from a two stage pressure cut farm tap.

STLP 0	Table of Contents Standard Designs Weld Fittings: Added Quick Opening Closures	January 1, 2014	July 1, 2014
STLP 2.01	Design Pressure 1. Design Formula D = Nominal outside diameter of pipe in inches (actual as produced diameter) Added "actual as produced diameter" In an SMR meeting there seem to be some confusion on the meaning of nominal. The addition was made to clarify that nominal outside diameter is the actual outside diameter of the pipe. 6. Dual Coat Steel Pipe Table: Corrected the Design Pressure for the 4, 6, and 8 inch pipe. Error was found in the computed design pressures by Gas Tech Engineering	January 1, 2014	July 1, 2014
STLP 3.01	Weld Fittings Added 7. Quick Opening Closures - ANSI Class 300 and Class 600, Sizes 2, 4, 6, and 8 inches. Gas Standards Committee approved these fittings and added them to the O&M.	April 1, 2010	July 1, 2014
TAPS 1	7. Gauge, Blow-down, By-pass Fittings 7. B.(1): Added weld punch tees as an acceptable fitting along with valve tees, save-a-valve nipples for use on high pressure and transmission line taps and stops. (1) Valve tees, save-a-valve nipple, weld punch tees or other approved fitting shall be used on transmission and high pressured distribution pipeline. Considerations that should be made when selecting a fitting are, but not limited to: (a) Pipe material	January 1, 2014	July 1, 2014

- (b) Pipe wall thickness
- (c) Blow-down time
- (d) By-pass capacity
- (e) Flow volume, cooling effect
- (f) Pipeline MAOP
- (g) Gas Tech Engineering specification

7. B.(3): Clarified that the leak test for cap/plug is done under normal operating pressure with leak detection fluid.

7. B.(5): Stipulated that punch shall be left in the up position on pipelines with MAOP greater than 60 psig.

7. B.(6): Stipulated that punch shall be left in the down position on pipelines with MAOP 60 psig or less.

7. C.: Deleted the distinction between pipelines with MAOP of 60 psig or less. 7. B. now applies to fittings used for taps and stops on all steel pipelines regardless of their MAOP.

Due to feedback from several operating areas that they were not equipped with tapping equipment required for valve tees or save-a-valve nipples and that they have not experienced problems with using punch tees, the SMR Team reinstated the use of punch tees. However, it was recognized that punch tees do have limited capabilities and may not be appropriate for all situations. The team added considerations that should be made when selecting a fitting. For pipelines with MAOP over 60 psig, Gas Tech Engineering will normally specify the fitting to be used.

TAPS 3.01	Mueller Fittings 4. Mueller Bottom-Out Line Stopper Fittings Removed the 2", 19 33 013, H-17160, 250 psig fitting. Mueller discontinued fitting years ago but during the consolidation of materials process and new stock code was set-up for the fitting. Mueller Bottom-Out Line Stopper Fittings for Use on Standard Wall Steel Pipe With Schedule 40 Bottom Opening: Added: 19 33 570 - 10" Mueller H-17260-748, Rating 275 psig. 19 33 571 - 12" Mueller H-17260-750, Rating 275 psig.	January 1, 2014	July 1, 2014
--------------	--	--------------------	-----------------

Supersedes: January 1, 2014

CHANGE SUMMARY

January 1, 2014

Change Summary January 1, 2014

Document	Change Summary	Previous Document Dated	Current Document Dated
Table of Contents	<p>New Sections added:</p> <p>PRES 2.06 - Pressure Change Request to Pipeline Supplies</p> <p>REPR 4 - Forms and Reference Materials</p> <p>SERV 2.07 - Gas Service G/Tech Mapping</p>	April 1, 2013	January 1, 2014
FORW	<p>2. Availability</p> <p>2. B.: New item: Added "An electronic and hardcopy of the latest version of Ameren Illinois Gas Operating and Maintenance Plan will be filed with the Illinois Commerce Commission</p> <p>2. C.: New item: Added language which identifies situations where the Company may find it necessary to issue new or revised procedures prior to being published in the O&M. Prior to Issuance such procedures would have to be reviewed by the Training group and approved by the Gas Standards and Procedures staff,</p> <p>4. Work Groups</p> <p>Updated the names of the groups within Gas Ops and Svs: Gas Transmission, Gas Tech Engineering, Training and Quality Assurance, Compliance, Standards and Procedures</p> <p>Changed Jim Burke Cell number to his personal phone: 618-964-4494</p> <p>Added Stan Treat as contact for Material issues</p>	April 1, 2013	January 1, 2014
ABND 0	Added dash line for ABND 2.01	January 1, 2013	January 1, 2014
ABND 1	<p>Updated work group names:</p> <p>2. A.: Gas Tech Engineering replaces Gas Engineering</p> <p>2. B.(3): Gas Tech Engineering replaces Gas Operations and Services</p> <p>2. B.(6): Gas Tech Engineering replaces Gas Operations and Services</p> <p>2. C.(1): Gas Tech Engineering replaces Gas Operations and Services</p> <p>2. C.(2): Gas Tech Services replaces Gas Operations and Services - Technical Support</p>	October 1, 2011	January 1, 2014

UNCONTROLLED IF PRINTED

- 2. C.(4): Gas Engineer replaces Gas Engineering
- 2. D.: Gas Tech Engineering replaces Gas Engineering
- Supervisor Gas Tech Services replaces Gas Operations and Services - Technical Services Supervisor

ABND 2.01	<p>Abandonment of Gas Facilities</p> <p>1, Mains</p> <p>1. A.(4): Added a sentence, "This leak test will be recorded on the DOJM or As-Built plans and maintained in the permanent job file."</p> <p>1. A.(8): Inserted new item, "Abandoned steel mains shall be inspected for evidence of internal corrosion. See CORR 1"</p> <p>1. A. (11): Gas Tech Engineering replaces Gas Operations and Services - Engineering.</p> <p>2. Services</p> <p>2. A.(8): Since service lines smaller than 2" do not require purging when abandoned, deleted language "after service line has been purged." Added "Always verify that a riser is on an abandoned service line before cutting."</p> <p>2. A.(10): Inserted new item, "Abandoned steel service lines shall be inspected for internal corrosion.</p> <p>See CORR 1"</p> <p>2. A.(14): Inserted new item, "Certain steel tees maybe retired by utilizing the MAZCO tool. Contact Gas Standards and Procedures at 217-535-5069 for approved applications and qualification requirements."</p> <p>2. A.(18): Added the use of a splice box (gel box) is an acceptable alternative to wrapping or encase the end of the tracer wire that is been cut when a plastic service has been cut-off.</p> <p>5. Records</p> <p>5. E.: Added new item, "If there is evidence of internal corrosion it shall be documented on the Corrosion and Steel Damage Evaluation form."</p>	April 1, 2013	January 1, 2014
ABND 2.03	<p>Abandonment of Transmission Facilities</p> <p>Updated work group names:</p> <p>2. D.: Gas Tech Engineering replaces Gas Operations and Services - Engineering and Gas Tech Services replaces Gas Operations and Services - Technical Services</p>	October 1, 2011	January 1, 2014
ACIG 1	<p>Accidental Ignition</p> <p>1. Objective</p>	January 1, 2013	January 1, 2014

UNCONTROLLED IF PRINTED

1. A.: Inserted new item: "Employees should take positive steps to work in a gas free environment whenever possible."

1. B.: Added the word "eliminate". "Employees shall be aware of the hazards of accidental ignition and take steps to eliminate or reduce the hazard."

1. C.: Formerly 1. A. was revised to: "Procedures in this section prescribe steps that are required to minimize the risk of accidental ignition in any structure or area where the presence of gas constitutes a hazard of fire or explosion."

Former 1. C.: Deleted the reference to access to fire extinguisher since it is covered in the procedures.

2. Sources of Ignition

2. A. Smoking and Open Flames: Smoking and open flames are prohibited in:

2. A.(1): Revised to: "Structures containing gas facilities where possible leakage and/or the presence of gas exists."

2. A.(2): Revised to: "Open areas containing gas facilities when the possibility of accidental ignition or gas-in-air mixture exists."

2. B.: Revised to: " Electric Arcing: Where the possibility of accidental ignition of gas-in-air mixture exists:

2. B.(1): Deleted extension cords: "Use intrinsically safe flashlights, portable flood lights and other power tools approved for use in hazardous atmospheres. See Specialized Tools and Equipment site under the Gas Operations and Services website in Scholar for approved intrinsically safe lighting equipment."

2. B.(2): Revised to: "Limit the use of internal combustion engines where possibility of accidental ignition of gas-in-air mixture exists."

2. B.(3): Replaced "metallic" with "steel" gas piping

2. B.(4): Combined the former 2. B.(5) language into this bullet point. "Ground squeeze tool and ground pipe when squeezing 1-1/4" and larger plastic pipe to eliminate external static prior to squeezing off the pipe. Where possible, use a separate excavation in a gas free atmosphere when squeezing off plastic pipe."

2. B.(5): Removed the descriptive information for purge pipe Reference PURG 2.01 which contains that information.

2. B.(6): Deleted "When venting gas, be aware of the wind direction and the direction the vent gas may follow to ensure gas is not being directed toward a potential source of ignition." This is covered in the purging section.

2. B.(7): Added: "Be aware of other potential ignition source such as; overhead power lines, induced voltage, weather conditions such as lightning.

ACIG
2.01

Work Area Protection

Janu-
ary 1,
2013

January
1, 2014

2. Tools and Equipment

2. A.: Deleted extension cords: "Use intrinsically safe flash-lights, portable flood lights and other power tools approved for use in hazardous atmospheres. See Specialized Tools and Equipment site under the Gas Operations and Services website in Scholar for approved intrinsically safe lighting equipment."

2. B.: Inserted new: "Cell phones or other consumer products that are not labeled as intrinsically safe shall not be taken into potentially gaseous atmosphere.

2. C. Revised by combining the former 2. D. and 2. E.: "Trucks, cars, excavation equipment, air compressors, generators, water pumps, welding machines and other portable equipment should be placed a safe distance upwind from blowing gas."

2. E.: Former 2. G. revised to: "Rectifiers should be turned off prior to cutting or separating the pipe under cathodic protection. Contact Corrosion Control personnel for the operating area to determine if pipeline is protected by rectifier." Deleted specifying only transmission and high pressure distribution main. Applies to any rectified pipeline.

3. Welding and Other Hot Work

3. A.: Revised to: "Prior to welding or other hot work in or around a structure or area containing gas facilities, an evaluation should be made with a CGI if the presence of natural gas-in-air is suspected."

3. B. and 3. C.: Raised the LEL limit to 30% from 10% to be consistent with definition of hazardous atmosphere. Welding or hot work should not be conducted if the atmosphere in an excavation is greater than 30% LEL unless the area is ventilated to remove the gas.

3. D.: Substituted "steel" for "metallic" pipe.

3. E.: Deleted language about shutting off or throttling valves since it isn't relevant.

3. E." Formerly 3. F.: Added "combustible" to gas-in-air mixture.

3. E.(2): Added "combustible" to gas-in-air mixture.

3. E.(5): Added reference to PURG 2.01 for use of vacuum purge or air mover.

UNCONTROLLED IF PRINTED

- 3. E.(6): Deleted language on monitoring work area with gas detector since it is covered in the Working Blowing Gas section.
- 3. F.: Substituted "steel" for "metallic" pipe.
- 4. Working with Plastic Pipe
- 4. D.: Change reference for purge pipe to PURG 2.01 from ACIG 1.
- 5. D.(2): Gas Tech Engineering replaces Gas Operations and Services - Engineering .
- 5. E.(1): Gas Tech Services replaces Gas Operations and Services - Technical Services.

BORE 2.05	<p>Typical Sewer Installations</p> <p>12. Add a period after the last sentence.</p>	April 1, 2013	January 1, 2014
CLAS 1	<p>2. Definitions</p> <p>2. D. Potential Impact Circle</p> <p>2. D.(2): Replaced "nominal diameter" with "actual outside diameter" of the transmission line.</p> <p>2. D.(3) Added new item: "Ameren Illinois will add ten (10) percent buffer to the Potential Impact Radius."</p> <p>3. Records</p> <p>3. Cleaned up the language that identifies Pipeline Integrity staff's responsibilities. "Pipeline Integrity staff is responsible for identifying and maintaining the class location and HCAs on all transmission lines. The Pipeline Integrity staff is responsible for identifying any changes in class location, changes in HCAs and notifying the Gas Supervisor of changes that affect leak surveys and patrols."</p>	Octo- ber 1, 2011	January 1, 2014
CLAS 2.01	<p>Class Location Determination</p> <p>1. A.: Clarified that Class Location is based on the number of structures within 660 feet of the "centerline of the pipeline" along a continuous mile of pipe.</p> <p>1. D.: Added new item: "Pipeline Integrity staff utilizes a computer program to perform Sliding Mile class location determinations."</p>	Octo- ber1, 2011	January 1, 2014
CLAS 2.02	<p>Annual Class Location and HCA Study</p> <p>1. A.: Revised language to clarify Pipeline Integrity staff conducts the annual review. "Pipeline Integrity staff conducting annual pipeline review shall record areas and locations of possible changes in the class location and HCA's. Changes in the class location can affect the patrol and leak survey requirements for the pipeline and may change the operating parameters for the pipeline. Changes</p>	Janu- ary 1, 2011	January 1, 2014

UNCONTROLLED IF PRINTED

in a HCA can affect the Integrity Management Plan and pipeline integrity inspection requirements for that area of the pipeline."

2. Action Required for Review of a Class Location Change

2. A.: Revised language to better describe when a class location change study is initiated. "Whenever there is an indication of a class location change for a segment of existing steel transmission pipeline operating at or above 40% of SMYS, the Pipeline Integrity staff shall immediately make a study to determine:"

2. A.(5): Replaced MAOP with Maximum Allowable Operating Pressure.

2. B.: Deleted language about updating leak survey patrol requirements since the updating is addressed later in this section. Changed the required time for confirming or revising MAOP from 18 months to 24 months to match what is in Part 192.

2. B.(1): Combined the previous 2. B.(1) and 2. B.(1)(a): "Action required for pipelines operating at less than 40% of SMYS. Identify any additional survey and/or patrol requirements and update the class location records, electronic mapping and Integrity Management records"

2. B. (2) and 2. B.(2)(a): Cleaned up language to be consistent with Part 192.

2. B.(2): Action required for pipelines operating at or above 40% of SMYS

2. B.(2)(a): If the segment involved has been previously tested in place for a period of not less than 8 hours, the MAOP must be confirmed or reduced so that the MAOP will not exceed the following:

- Class 2 locations - 0.8 times the test pressure
- Class 3 locations - 0.667 times the test pressure
- Class 4 locations - 0.555 times the test pressure

2. B.(3): Added new item regarding updating surveys and patrols. "Identify any additional survey and/or patrol requirements and update the class location records, electronic mapping and Integrity Management records.

CNTS
1

1. C.: Continuing surveillance language was removed leaving a description for System Review. "The System Review is an analysis of the data collected from the surveys, patrols and inspections completed on the transmission and distribution facilities."

April 1, 2012, January 1, 2014

2. Periodic Inspection of Facilities

2. B.(1); Replaced "construction activities" with "excavation activities".

2. B.(2): Inserted new item which should be reported to Gas Supervisor: "Possible structures or encroachment located over or adjacent to the gas pipeline."

2. C.: Updated to which group failed or defective material should be sent. "Gas Standards and Procedures, 10th Floor, 607 East Adams, Springfield, IL 62701".

2. D.: Deleted the inspection of bulletin board for Ameren's Alcohol and Illegal Drugs Policy and Employee Assistance Program.

3. Meter Reading

3. B.: Added meter readers can code conditions into their processors as an alternative to contacting their supervisor.

3. B.(3): Revised one of the conditions meter readers should report to: "Evidence of overbuilding, obstruction, or deterioration of meter set." Removed atmospheric corrosion and disbonded coating since leak surveyors are trained to report these conditions.

4. Reporting Gas Leaks

4. A.: Added examples of non-gas field personnel such as meter readers, contract locators, summer painters, electric personnel. Replaced "smell a gas leak" to "detect odor of gas". Inserted the word "then". This clarifies that non-gas field personnel can continue with their work after reporting the gas odor. Now reads; "Non-gas field personnel such as meter readers, contract locators, summer painters, electric personnel who detect odor of gas at a customer's premise shall immediately report the gas odor to the Company and then may continue their work after reporting the leak."

5. System Review

5. A. & B.: Capitalized System Review

5. E.: Added "abnormal and unusual maintenance conditions" to the conditions to be reviewed.

"Failures, other abnormal or unusual operating and maintenance conditions should be reviewed."

7. System Review Report

7. A., B., C. and D.: Capitalized System Review

7. C.: Gas Tech Services replaces Gas Technical Services.

7. D.: Managing Supervisor Operations - Gas Training and Quality Assurance replaces Gas Compliance

CNTS
2.01

Surface Subsidence Areas

1. B.: Replace "Gas Engineering" with "Pipeline Integrity" as the group the Gas Supervisor should notify when there is suspected subsidence that may affect gas facilities. "Surface subsidence can result from underground mining oper-

Octo-
ber 1,
2011

January
1, 2014

ations, landfills, or embankments. The Gas Supervisor will notify Pipeline Integrity of all reported suspected subsidence that may affect gas facilities."

1. C.: Combined with 1. B.

1. D.: Deleted notifying Pipeline Integrity and Gas Operations and Services with transmission or high pressure distribution facilities are involved. Pipeline Integrity is notified when any gas facilities are involved as stated in 1. B.

6. Embankments

6. A.(1): Gas Tech Engineering replaces Gas Operations and Services

6. B.(3)(d): Clarified that corrective action taken when compression couplings/fittings are within an embankment subsidence area should be encapsulate or remove the coupling/fitting. Replaced "replace" with "remove".

7. Records

7. B.: Inserted new item: "The Gas Supervisor shall notify Pipeline Integrity of all reported suspected subsidence that may affect gas facilities."

CNTS
4

Forms and Reference Materials

April 1,
2012 January
1, 2014

Form 01 - System Review Form updated with the following:

Corrosion Control Deficiencies Reviewed? Added (Contact Corrosion Control Group)

Class Location/HCA Changes Reviewed? Added (Contact Pipeline Integrity Group)

Odorant Intensity Survey Locations Reviewed? Added (Contacted Gas Tech Services)

System Maps Updated? Added (Contact DDC/PDC)

Insert new Item: "Failed Material Submitted for this Review?"

Deleted "Summary Report" and replaced with "Pipeline Facilities Experiencing Abnormal or Unusual Operating and Maintenance Conditions.

CONS
1

1. C.: Illinois Operations Support - Contractor Services Supervisor replaces Illinois Construction Services - Construction Supervisor

Janu-
ary 1,
2013 January
1, 2014

2. A.: Gas Tech Engineer replaces Gas Operations and Services - Engineer replaces

2. A.(7): Gas Tech Engineering replaces Gas Engineering

3. A.: Gas Tech Engineer replaces Gas Operations & Services Engineer.

Illinois Operations Support - Contractor Services Supervisor replaces Illinois Construction Services - Construction Supervisor

3. B: Gas Tech Engineering replaces Gas Engineering

3. E., F., G. H.: Illinois Operations Support - Contractor Services Supervisor replaces Illinois Construction Services - Construction Supervisor

4. Construction Inspector

4. B.: Revised wording, " Contractors hired as construction inspectors shall attend Gas Construction Inspector Training prior to inspecting such work."

5. Major Areas of Focus

5.A.(5): Removed 's

and services 's

which was deleted in January 1, 2013 update

CONS 2.01	Construction Inspector Responsibilities 2. B.(3): Gas Tech Engineering replaces Gas Engineering. Supervisor Gas Tech Services replaces Gas Operations and Services - Technical Service Supervisor 8. I.: Gas Tech Engineering replaces Gas Operations and Services - Engineering	January 1, 2013	January 1, 2014
CORR 0	Changed CORR 2.12 to Tapecoat TC Color Coat from Denso Color Tape	April 1, 2013	January 1, 2014
CORR 1	2. Cathodic Protection Measurements 2. B.: In this section changed P/S readings to volts from millivolts; -0.850 volts instead of - 850 millivolts. 2. C.: Inserted new item: 2. C.: "Although a reading of -0.850 volts is considered adequate, if a reading less negative than -0.900 is obtained when completing a Buried Pipe Examination or reading GCS CP test points the Corrosion Control person for the area must be notified by phone, email, or mail. (1). A copy of the Buried Pipe Examination shall be sent to the Corrosion Control person for the area. See item 5. B. below. (2). The Corrosion Control person for the area shall be notified of deficient readings on GCS CP test points. The compliance date to bring the test point into compliance remains in effect until a reading of, or more negative, than -0.900 is	January 1, 2013	January 1, 2014

obtained. See item 7. I. below." 3. Cathodic Protection of New and Replacement Pipeline Facilities

3. B.: In this section changed P/S readings to volts from millivolts; -0.850 volts instead of - 850 millivolts.

5. External Corrosion

5. B.: Clarification to reinforce it is a copy of the Buried Pipe Examination that is sent to Corrosion Control person.

6. Internal Corrosion 6. A.: Separated tapping coupons from abandoned pipe. "All tapping coupons are to be inspected for evidence of internal corrosion and documented on the Buried Pipe Examination form. See CORR 2.30"

6. B.: "Sections of pipe abandoned or removed for any reason shall be inspected for evidence of internal corrosion."

6. C.: Revised language when there is evidence of internal corrosion; "If evidence of internal corrosion is found in any steel pipe contact the Corrosion Control person for that operating area or qualified Gas Engineer."

6. D.: Minor language change, removed "for that operating area". "Corrosion Control person or qualified Gas Engineer will complete a Corrosion and Steel Damage Evaluation form, CORR 2.31, and enter the information into Pipe Exam Database."

9. Test Lead Connections

Added reference to CORR 3.14 for connection methods.

12. Atmospheric Corrosion

12. C. Corrective Action

12. C.(1): Revised to clarify that when atmospheric corrosion or disbonded coating is found, corrective action must be completed within 12 months.

12. E.(3): Added requirement that if the pit depth is greater than 10% of wall thickness on transmission facilities or greater than 70% on distribution facilities, the inspection will be documented on the Corrosion and Steel Damage Evaluation form.

12. E.(4): Minor revision to wording: "Once cleaned and inspected, the pipeline facilities shall be coated with an approved coating." Removed the word "primed".

13. Pipeline Facilities That Need to be Painted

13. B.: Facilities Maintenance

13. B.(1): Revise job title to Managing Supervisor Operations - Gas Training and Quality Assurance from Manager - Gas Compliance.

CORR 2.03	<p>Coatings</p> <p>1. Approved Coatings</p> <p>1. A.(1): Added a 12 mil minimum and 16 mil maximum coating thickness for the fusion bonded epoxy (FBE).</p> <p>1. A. (2): Specified that the minimum thickness of the abrasive resistant overcoating (ARO) should be 20 mils. Added the (ARO)</p> <p>1. F. Soil to Air Interface Zone</p> <p>1. F.(2): Inserted new item: "For anodeless risers do not wrap the PE to steel transition area. The pipe above the transition should be painted.</p> <p>1. F.(3): Added "gas carrying" for the new risers that may need to be wrapped with non-waxed cold applied tape if significant settling of the soil is expected.</p> <p>4. Approved Field Applied Epoxy Coatings</p> <p>Added the Denso Protal 7200 and Trenton EON 1000GP repair cartridge. The repair cartridge replaces the Hot Melt Stick for repairing FBE coating. Add contact information for purchasing the repair cartridge guns.</p> <p>6. Approved Paint Specification</p> <p>Added Sherwin-Williams Ameren Medium Green paint that Kelly Coppennoll requested that matches painting on some existing regulator stations. The Ameren Medium Green paint is available in gallon cans and in 12 oz aerosol cans.</p> <p>6. A.(4) Note: Deleted "meter gray" so either the meter gray or medium green aerosol paint can be used for touch-ups.</p>	April 1, 2013	January 1, 2014
CORR 2.07	<p>Tapecoat H35</p> <p>3. Coverage</p> <p>3. A.: Updated table for Footage of Pipe Wrapped per Roll of Tapecoat H35</p> <p>3. B.: Corrected stock code for TC Omniprime 49 22 084</p>	Janu- ary 1, 2011	January 1, 2014
CORR 2.08	<p>Denso Butyl 35</p> <p>3. A.: Revised table to "Footage of Pipe Wrapped per Roll of Denso Butyl 35"</p>	Janu- ary 1, 2011	January 1, 2014
CORR 2.12	<p>Tapecoat TC Color Coat replaced Denso Color Tape</p> <p>3. A.: Revised table to "Footage of Pipe Wrapped per Roll of TC Color Coat"</p> <p>3. B.: Updated table on quantity of TC Profile Putty needed for different size fittings.</p>	Janu- ary 1, 2011	January 1, 2014

CORR 2.15	<p>Coating Inspection</p> <p>2. Inspection Requirements</p> <p>2. B.: Updated inspection voltage information and table since coating thickness specifications have been revised. Added the following information: 2. B.(1:) Inspect coating using an approved holiday detector with appropriate voltage range. If the voltage output of a holiday detector does not match the indicated voltage in the chart below, use the next lower setting.</p> <p>2. B.(2) Average total mil thickness 12 mil thru 20 mil would be FBE coating only.</p> <p>2. B.(3) Average total mil thickness 32 mil thru 50 mil would be for FBE with ARO</p> <p>2. B.(4) If the average total thickness is not shown on the chart, contact Superintendent Corrosion Control for the proper test voltages.</p> <p>The inspection voltage table has been revised by listing mil thicknesses in two mil increments with an associated minimum and maximum voltage. Total mil thicknesses of 12 to 20 would be for FBE coating only and mil thicknesses of 32 to 50 would be for FBE with ARO coating.</p>	Janu- ary 1, 2013	January 1, 2014
CORR 2.19	<p>Cathodic Protection Test Points</p> <p>3. Cased Crossings - reformatted</p> <p>Revised language to specify addition tests are for isolation.</p> <p>3. A.: Now reads "Comparison between pipe-to-soil potential and casing-to-soil potential. Both potentials should be measured with the half cell in the same location for a valid comparison. If the difference in potentials is less than 25 mV additional tests for isolation shall be performed. See CORR 3.17</p> <p>3. B.: Now reads "If it is necessary to perform pipe-to-soil readings at different nearby locations, additional testing for isolation shall be performed if the difference in potentials is less than 200 mV.</p> <p>Note: If the casing is documented as shorted and is filled with dielectric filler, only a pipe-to-soil potential for the pipeline is required.</p> <p>Cased crossings with plastic mains do not need to be monitored for electrical isolation.</p>	April 1, 2013	January 1, 2014
CORR 3.15	<p>Rectifier Installation</p> <p>4. Rectifier Ground Bed Header Connection</p>	April1, 2013	January 1, 2014

4. A.: Added stock codes for the Dryconn VisiLock Gel Anode Splice Box, 49 22 428, and the 3M A Anode Splice Box, 62 55 100.

DAMG
0

DAMG 1:
Inserted new item 7. Protection of Excavated Facilities.
8. & 9. Added "Steel" for the 8" and Larger Main

January 1, 2012

January 1, 2014

DAMG
1

2. B. (2) Emergency Locate Request
2. B.(2)(b): Added "An open cut utility locate" as an example of an Emergency locate request.
2. B.(3) Joint Meet Locate Request
2. B.(3)(a): Updated to reflect new regulations for Joint Meets. "It is not a valid locate request and is for meeting purposes only."
2. B.(3)(c): Revised: "Excavators are required to obtain separate locate requests following the Joint Meet for the area to be located." Deleted the language about a joint meet being a 96 hour process and the locating company has 2 days to locate following the joint meet.
2. B.(3)(d): Revised: "A joint meet is a minimum forty eight (48) hour process."
7. Protection of Excavated Facilities - New Item
A. Exposed Ameren gas facilities may be protected from continuing excavation during construction by utilizing Safety Wrap, see stock codes listed below. (1) 4922424 - for 2" or 3" diameter pipe, 48" long.
(2) 4922425 - for 4" diameter pipe, 48" long.
(3) 4922426 - for 6" diameter pipe, 48" long.
(4) Other sizes available non-stock. B. Safety Wrap may be used for temporary protection or permanent protection for PE pipe.
C. Safety Wrap may only be used for temporary protection for steel pipe, and cannot be used for permanent protection.
8. Excavating Near a Transmission, High Pressure Distribution and 8" and Larger Steel Main. (Added the word "Steel")
For clarification have added the word "main", the statement "facilities with MAOP of 100psig or greater", and "steel distribution main" to the following items.
8. A.: Clarified: "Ameren Illinois must take special precautions for Locate Requests in the vicinity of all transmission mains, high pressure distribution facilities with MAOP of 100 psig or greater and steel distribution mains eight (8) inches and larger."

January 1, 2013

January 1, 2014

8. B.: "When Ameren Illinois' locator determines the excavation on a Locate Request may be within fifteen (15) feet of a transmission main, high pressure distribution facility with MAOP of 100 psig or greater or a steel distribution main eight (8) inches and larger, the Locator will forward the Locate Request to Ameren Illinois Damage Prevention group"

8. C.: "When marking transmission mains, high pressure distribution facilities with MAOP of 100 psig or greater and steel distribution mains eight (8) inches and larger, Locator will use flags and marking paint."

8. E.(1): " Where excavation activities are within fifteen (15) feet of a transmission main, high pressure distribution facility with MAOP of 100 psig or greater or a steel distribution main eight (8) inches and larger, Ameren Illinois Damage Prevention personnel or qualified contractor shall monitor the excavation site and document the excavation activities. All documentation shall be maintained on the Damage Prevention and Monitoring SharePoint site or by the local area. The location of the excavation and the condition of the main, if exposed, shall also be documented on the Buried Pipe Examination form (Stock Code 37-41-382), CORR 2.30, or an electronic equivalent."

8. E.(2): "Ameren Illinois Damage Prevention personnel or qualified contractor will contact the excavator to inform them that a transmission main, high pressure distribution facility with MAOP of 100 psig or greater or a steel distribution main eight (8) inches and larger is in the vicinity and an additional evaluation may be required."

8. E.(3): "Where excavation activities are not within fifteen (15) feet of a transmission main, high pressure distribution facility with MAOP of 100 psig or greater or a steel distribution main eight (8) inches and larger, Ameren Illinois Damage Prevention personnel or qualified contractor shall document these findings and the documentation shall be maintained on the Damage Prevention and Monitoring Share-Point site or by the local area. No further action is required."

8. F.:" When boring or trenchless technology is utilized to cross a transmission main, high pressure distribution facility with MAOP of 100 psig or greater or a steel distribution main eight (8) inches and larger, Ameren Illinois personnel or qualified contractor must visually inspect the excavation while in progress until it clears the existing marked facility and verifies the facility was not damaged. A Buried Pipe Examination form, CORR 2.30 or an electronic equivalent shall be filled out if the facility is exposed."

In 8. E.(1): Damage Prevention and Monitoring Sharepoint site replaced the name Excavation Sharepoint site. Refer-

ence to CORR 2.30 or an electronic equivalent was added for Buried Pipe Examination form.

In 8. F.: Reference to CORR 2.30 or an electronic equivalent was added for Buried Pipe Examination form.

9. Emergency Locate Request Near Transmission, High Pressure Distribution, or 8" and Larger Steel Main

For clarification have added the word "main", the statement "facilities with MAOP of 100psig or greater", and "steel distribution main" to the following items.

9. A.: "In addition to responding to the locate request Ameren Illinois must take special precautions for emergency excavation notices in the vicinity of a transmission main, high pressure distribution facility with MAOP of 100 psig or greater or a steel distribution main eight (8) inches and larger."

9. B.: "When excavation on an Emergency Locate Request may be within fifteen (15) feet of a transmission main, high pressure distribution facility with MAOP of 100 psig or greater or a steel distribution main eight (8) inches and larger, the Locator will notify Ameren Illinois Damage Prevention personnel of the pending excavation and remain at the site until relieved by a qualified Ameren Illinois personnel or qualified contractor."

10. Facility Location Information

10. B.: Electronic mapping system replaces AM/FM System. "One Call" added to JULIE

12. Records

12. C.: Typo correction small letter "e" for excavation.

DAMG
2.01

Reporting JULIE Violators

3. Investigation of Reportable Violations

3. C.: "Supervisor Damage Prevention" replaces "Allen Kish" as to who to contact for assistance

4. Reporting a Suspected Violation

4. A. & 4. C.: Corrected group name to Damage Prevention Group.

6. Notification of Damaged Underground Facilities

6. C.: Revised language to : " In the event of any damage to any underground utility facility including Ameren Illinois' facilities damaged by Ameren Illinois crews or their contract crews that results in the escape of any flammable, toxic, or corrosive gas or liquid, the person responsible for the excavation or demolition shall call 911 to notify authorities of the damage." Important to note even if Ameren Illinois crew or an Ameren Illinois contractor damages an Ameren Illinois buried facility a 911 call is required That is the JULIE Law. If

October 1,
2011

January
1, 2014

an Ameren gas crew hits an Ameren gas line they are still required to call 911 but they can tell the 911 operator that a crew is on site and has the situation under control.

EMER 0	Added dash lines to EMER 2.10	Janu- ary 1, 2013	January 1, 2014
EMER 2.01	Customer Contact Center 4. Emergency Gas Call Significant revisions have been made in this section to reflect an updated script that Call Takers are now using when an emergency call is received. Some of the major revisions included in the updated script are listed below. 4. G. Inside Strong Odor, Hear, or See: Eliminated asking customer to try to find out where odor is coming from and to check pilots. Now are advising caller not to open windows or doors to ventilate. Customers are advise to evacuate the premise until we are able to respond and determine the severity of the problem. 4. H. Outside Odor, Hear or See: They are not asking if a gas line or facility is damaged or is gas blowing. There is an expanded list of instructions that are to be provided to caller. 7. Receiving a Carbon Monoxide Call: A minor change here in that all Carbon Monoxide calls from customers will be entered in OAS for tracking purposes. 9. Call Received from a Customer: Reorganized the script with the same basic information as before but added more instructions for Call Takers on how to enter call in OAS.	July 1, 2012	January 1, 2014
EMER 2.04	Gas Field Personnel In the following items clarified that when a non-emergency valve is used to sectionalize the gas system during an emergency, the valve will be designated an emergency valve after the emergency situation has been resolved. Replaced the word "control" with "isolate or sectionalize". 3. Outside Odor Compliant - Hazardous Condition 3. I.: "After the emergency situation has been evaluated, isolate the leak utilizing the methods below appropriate to the extent of the emergency. For example, if gas migration is creating an immediate hazard it may be prudent to utilize emergency valves rather than excavating and squeezing pipe to reduce the immediate hazard. If a non-emergency valve is used to isolate or sectionalize the gas main segments during an emergency situation, the valve will be des-	April 1, 2013	January 1, 2014

ignated as an Emergency Valve after the emergency situation has been resolved. See VALV 2.01"

4. Major Leaks or Line Breaks

4. F.: "After the emergency situation has been evaluated, isolate the leak utilizing the methods below appropriate to the extent of the emergency. For example, if gas migration is creating an immediate hazard it may be prudent to utilize emergency valves to reduce the immediate hazard rather than excavating and squeezing pipe. If a non-emergency valve is used to isolate or sectionalize the gas main segments during an emergency situation, the valve will be designated as an Emergency Valve after the emergency situation has been resolved. See VALV 2.01"

5. Gas in a Sewer - Hazardous Condition

5. G.: "After the emergency situation has been evaluated, isolate the leak utilizing the methods below appropriate to the extent of the emergency. For example, if gas migration is creating an immediate hazard it may be prudent to utilize emergency valves rather than excavating and squeezing pipe to reduce the immediate hazard. If a non-emergency valve is used to isolate or sectionalize the gas main segments during an emergency situation, the valve will be designated as an Emergency Valve after the emergency situation has been resolved. See VALV 2.01"

10. Loss and Restoration of Service

10. H.: Replaced 500 people with 1000 people, approximately 400 meters based on 2.5 people per household.

10. W. (2): Added the Ameren Illinois phone number 1-800-755-5000 for the customer to call if their gas has not been turned back on.

EXCV
1

1. A.: Revised to: "Procedures are required to provide for safety during maintenance and operations activities which includes taking adequate precautions in excavated trenches to protect personnel from the hazards of cave-ins, traffic and equipment, falling loads, or hazardous atmospheres." Added traffic, equipment, falling loads and replaced unsafe accumulations of combustible gas.

January 1, 2011

January 1, 2014

2. Excavations

2. B.: Revised to: "Excavations five (5) feet or more in depth, or excavations of any depth where the Competent Person determines that a cave-in hazard to personnel exists, shall be protected from cave-ins by sloping, benching, and/or shoring/shielding, as appropriate for the soil type(s) before personnel are allowed to enter." Added language "excavations of any depth where Competent Person determines cave-in-hazard to personnel exists."

2. E.: Clarified that excavations in which personnel will enter shall be inspected daily by Competent Person.

5. Soil Classification

5. B.: Revised to: "The Competent Person is required to perform a soil analysis and soil classification to determine the potential for cave-in of an excavation, and to determine the appropriate protective measures, such as sloping, benching, shoring or shielding (trench) box to be utilized." Added the classification to determine the potential for cave-in and determine the appropriate protective measures.

5. C.: Added language that states the soil classification must include both visual and manual tests.

EXCV
2.01

Prior to Excavation

1. Job Site Inspection

1. B.: "shall" replaced "should". "The Competent Person shall inspect the area of proposed excavation for situations or conditions that may pose a potential hazard to the excavation such as:"

1. B.(9): Added "or overhead": " Presence of underground or overhead utilities in the immediate area."

2. Job Preparation

2. A.(3): Added "of potential risk of cave-in or" and "and exit the excavation". "Instruction to employees that at the first sign of potential risk of cave-in or unexpected soil movement, they are to immediately call a halt to operations and exit the excavation until the Competent Person inspects the excavation."

2. B.: Added "or working within the tolerance zone". "Underground utilities shall be located prior to excavating and exposed as practical by hand or vacuum excavation when crossing or working within the tolerance zone."

2. D.: Added "and when necessary, measures taken to prevent inadvertent entry such as barricades, stop logs, or spotter". "Vehicles and equipment not involved in excavation should be parked away from the excavation site to minimize surcharge load on excavation walls and when necessary, measures taken to prevent inadvertent entry such as barricades, stop logs or spotter."

Janu-
ary 1,
2011

January
1, 2014

EXCV
2.02

Excavation Flowchart

Removed the step "Type C soil, personnel entering head below top plane of excavation and pump required to remove water" This is covered by the question, "Potential for cave in"

Janu-
ary 1,
2011

January
1, 2014

EXCV
2.03

Working in Excavation

January 1,
2012

January
1, 2014

1. Beginning Excavation

1. A.: Added "in order to aid in classification of the soil type". "As excavation begins, the Competent Person should watch how the soil material reacts as it is deposited, in order to aid in classification of the soil type".

1. A.(3): Added "Watch for water standing or running into the excavation." "Observe the moisture content of the soil as the excavation gets deeper. Watch for water standing or running into the excavation."

1. A. (5): New: "Watch for layers sloping into the excavation."

1. C.: Inserted a new item concerning protecting workers and public from falls into an excavation.

1. C.: "Protect workers and public from falls into the excavation or contact with construction equipment and materials. General considerations would include depth of excavation, proximity to roadways or pedestrian routes, and length of time excavation will be left open. When working near roads, the following precautions from the Manual on Uniform Traffic Control Devices, MUTCD, should be followed:" (1) Pedestrians should not be led into direct conflicts with work site vehicles, equipment or operations.

(2) Rope off all work areas with a barricade tape or equivalent and place tape or equivalent to designate a safe pedestrian walkway around obstructions, such as ditches, holes, tool carts, trailers, or piles of dirt on sidewalks. Barricade tape should have "Caution" or "Caution Do Not Enter" printed on the tape.

(3) Pedestrians should be provided with a safe convenient travel path that replicates as nearly as possible the standard sidewalk or footpath.

(4) Consideration should be made to separate pedestrian movements from both work site activity and motor vehicle traffic. (5) Pedestrians should be appropriately directed with advance signing that encourages them to cross to the opposite side of the roadway.

(6) Whenever it is feasible, closing off the work site from pedestrian intrusion may be preferable to channelizing pedestrian traffic along the site with temporary traffic control devices.

(7) When working underground, on private property, in pedestrian lanes or parkways, close all holes in the earth before leaving the location. If this is impracticable, fence the area with a safety fence or equivalent to prevent small children or animals from falling into the excavation. 1. D.: Added "The excavating equipment operator should scale or sweep the excavation face to eliminate loose material that

UNCONTROLLED IF PRINTED

could fall into the excavation and injure a worker." Now reads:

"Soil shall be deposited no closer than two (2) feet from the edge of the excavation as a means for protecting gas field personnel from loose soil material that could fall into the excavation. The excavating equipment operator should scale or sweep the excavation face to eliminate loose material that could fall into the excavation and injure a worker."

1. E.: Clarified by stating "All foreign underground utilities within 18 inches of the proposed excavation shall be uncovered"

2. Inspection of Excavation

2. C.: Revised to read: "Additions/changes to the "Excavation / Soils Checklist" are required whenever there is a change in the soil characteristic of an excavation that could affect the stability of the excavation."

3. Working in Excavation

Previous 3. A & B. & C.: were deleted and incorporated in other items.

3. D.: (Formerly 3. G.) Added "or excavations of any depth where a cave-in hazard to personnel exists". Now reads

"Excavations five (5) feet and deeper, or excavations of any depth where a cave-in hazard to personnel exists, shall have a properly designed protective system to protect workers from a cave-in."

3. G. is former 3. J

3. G.: Gas field personnel shall not work in excavations where there is accumulating or accumulated water unless:

- (1) The water is diverted around the excavation or
- (2) The water is removed from the excavation. The water removal equipment should be monitored on a regular basis to ensure proper operation

Deleted "Gas field personnel are protected from the effects of the accumulated water by wearing rubber boots or waders"

EXCV
2.04

Soil Analysis & Classification

2. Visual Analysis

2. B.(4): Insert new item; "Observe the excavation for signs of bulging, boiling, or sloughing."

3. Manual Analysis

3. A.(1)(a): Inserted new item under Test for Plasticity; "Note that most soils are a mixture of cohesive and granular materials. The goal of plasticity testing should be to determine the sensitivity of the soil to water content change."

January 1,
2011

January 1,
2014

UNCONTROLLED IF PRINTED

Soils with high plasticity will remain cohesive and maintain their strength over a wider range of water content. Soils with low plasticity will be very sensitive to water content changes and will lose their strength quickly, such as during rainy conditions."

3. A.(1)(b): Added "free of large granular material". Now reads "Mold a moist or wet soil sample, free of large granular material, into a ball and then roll it into a 2" long 1/8" diameter thread.

3. A.(1)(c): Added "has a high plasticity" so it now states "If the thread can be held on one end without breaking, the soil is cohesive and has high plasticity"

3. A.(1)(d): Added "has low plasticity" so it now states "If the sample breaks or cannot be rolled into a thread, the soil has low plasticity."

3. A.(2) Dry Strength Test

3. A.(2)(a): Added "Handle" so now states "Handle and observe a dry clump of the soil to see how it breaks apart.

6. Excavation/Soils Checklist

6. A.: Insert new item; "An Excavation/Soils Checklist is required for every excavation greater than two (2) feet in depth if personnel will enter the excavation."

6. B.: (Formerly 6. A.) revised to "The Competent Person is required to complete the Excavation/Soils Checklist form prior to personnel entering the excavation." Added "prior to personnel entering the excavation."

6. C.: Revised wording to "For excavations where an Excavation/Soils Checklist is required, a separate Checklist must be completed for each day an excavation is left open and workers are entering the excavation"

EXCV
2.05

Sloping Protective System

1. A.: Added "into which personnel will enter" to clarify when a protective system is required. Now states "A protective system is required on all excavations five (5) feet in depth or greater into which personnel will enter."

1. B.: Revised wording to "A protective system is also required for all excavations less than five (5) feet in depth if the Competent Person determines there is an indication of potential cave-in risk to personnel entering the excavation."

1. C.: Replaced with "The Competent Person shall select the appropriate configuration based on the results of soil classification and operating conditions in the area of the excavation."

1. D.: New item added: "The Competent Person shall inspect the excavation daily for indications of distress that

Janu-
ary 1,
2011

January
1, 2014

- would adversely affect the stability of the excavation such as:
- (1) Cracks in vertical soil face
 - (2) Surface cracks behind the excavation
 - (3) Water seepage
 - (4) An increase in highly saturated soil at lower level of excavation
 - (5) Sloughing of soil from vertical faces

2. Sloping Protective System

2. A.(2).(a),(b),(c): Changed dimensions to feet from inches.

1-1/2H : 1V (e.g. 9' horizontal to 6' vertical)

1H : 1V (e.g. 6' horizontal to 6' vertical)

3/4H : 1V (e.g. 4' horizontal to 6' vertical)

EXCV
2.06

Sloping and Benching Protective System

1. A. thru D.: Same language as in EXCV 2.05 1.

1. A.: A protective system is required on all excavations five (5) feet in depth or greater into which personnel will enter.

1. B.: A protective system is also required for excavations less than five (5) feet in depth if the Competent Person determines there is an indication of potential cave-in risk to personnel entering the excavation.

1. C.: The Competent Person shall select the appropriate configuration based on the results of soil classification and operating conditions in the area of the excavation.

1. D.: The Competent Person shall inspect the excavation daily for indications of distress that would adversely affect the stability of the excavation such as: (1) Cracks in vertical soil face

(2) Surface cracks behind the excavation

(3) Water seepage

(4) An increase in highly saturated soil at lower level of excavation

(5) Sloughing of soil from vertical faces
2. Sloping & Benching Protective System

Former 2. D. and 2. E. were moved into the General section as shown above.

2. E.: New item; "A single bench is allowed in these configurations for Type A and Type B soils: (1) In Type A soil, a four (4) feet vertical face at the bottom with a three (3) feet wide bench is allowed

(2) In Type B soil, a four (4) feet vertical face at the bottom with a four (4) feet wide bench is allowed.

January 1, 2011

January 1, 2014

EXCV 2.07	<p>Aluminum Hydraulic Shoring Protective System</p> <p>2. Hydraulic Shoring</p> <p>2. D.: Relocated previous 2. U</p> <p>2. E.: Relocated previous 2. V</p> <p>2. F.: Expanded language to: "Hydraulic shoring shall be installed from top down and removed from bottom up. At no time may personnel enter the excavation to install the shoring components necessary to protect from cave-in."</p> <p>2. O.: Revised wording to "The ends of the trenches must be protected from cave-in by sloping, benching, or trench-end shielding."</p> <p>2. S.: Expanding language on the use of sheeting. "Sheeting must extend to the top of the excavation and to within two (2) feet of the bottom. If shoring/sheeting is used on a lower vertical section of a slope, the sheeting must extend a minimum of eighteen (18) inches above the bottom of the slope, in order to protect personnel from material rolling into the trench."</p> <p>2. T.: Inserted new item: "Excavations deeper than four (4) feet shall have a means for workers to enter and exit which meets the requirements of EXCV 2.03. The means to enter or exit shall be located no more than twenty five (25) feet laterally from any worker. A ladder must be provided in each location between shoring cylinders where personnel are working."</p> <p>2. V.: Expanded language on walkways. "Any walkways crossing the excavation must meet OSHA walkway standards. Personnel must be protected from falls into excavations that are six (6) feet or deeper."</p> <p>2. W.: Slight modification to language for monitoring atmosphere in a trench when a hazardous atmosphere is expected. "When it can be reasonably expected that a hazardous atmosphere could exist, the atmosphere must be monitored for oxygen content and combustible or toxic gases with a calibrated gas detector."</p>	January 1, 2011	January 1, 2014
EXCV 2.08	<p>Trench Box Protective System</p> <p>2. Trench Box Protective System</p> <p>2. E.: Previous 2. I. has been expanded to "The ends of the box must be either enclosed with aluminum slats, Finn Form plywood or must be sloped at the appropriate allowable slope."</p> <p>2. N.: Expanded language on walkways. "Any walkways crossing the excavation must meet OSHA walkway standards. Personnel must be protected from falls into excavations that are six (6) feet or deeper."</p>	January 1, 2011	January 1, 2014

2. O: Slight modification to language for monitoring atmosphere in a trench when a hazardous atmosphere is expected. "When it can be reasonably expected that a hazardous atmosphere could exist, the atmosphere must be monitored for oxygen content and combustible or toxic gases with a calibrated gas detector."

EXCV
2.09

Working in Hazardous Atmosphere

January 1,
2011

January
1, 2014

1. B.: Expanded language on what constitutes a hazardous atmosphere. "A hazardous atmosphere is present when gas concentrations are measured with a gas detector at 30% LEL or greater when the oxygen level is measured at 19.5% or less, or when toxic gases (carbon monoxide, hydrogen sulfide, etc) are present."

2. Prior to Beginning Work

2. A.: Added the word utilize so now states Gas field personnel shall explore and utilize all available options to eliminate a hazardous concentration of natural gas in an excavation before entering the excavation. This would include:

2. B.: Expanded language on working in an oxygen deficient atmosphere. "If the oxygen level of an excavation is less than 19.5%, ventilating equipment should be used to provide additional oxygen to the excavation and reduce gas concentrations. Gas field personnel working in oxygen deficient excavations shall be provided with breathing equipment and emergency rescue equipment (full-body harness, life line, and means to positively extract a worker) if the oxygen level cannot be raised above 19.5%. In addition, standby personnel, outfitted with the same level of protective equipment, shall be present to provide emergency assistance as needed."

3. Entering Excavation

3. A.: Added "or toxic gases". "The atmosphere of the excavation shall be tested with a gas detector to determine the amount of combustible or toxic gases present and the oxygen level."

3. D.: Revised language to: "Gas field personnel wearing their standard work clothing may work in excavations that are not oxygen-deficient (at least 19.5%), but that may have gas concentration of less than 30% LEL as long as the gas concentration does not rise to 30% LEL or greater."

4. Hazardous Concentration of Natural Gas - Level 1 Requirement

4. A.: Added a reference to WWBG 2.01 for the Level 1 PPE. "The following identifies a hazardous concentration of natural gas in an excavation which requires gas field personnel to wear Level 1 PPE as specified in WWBG 2.01, (no supplied-air breathing apparatus)."

UNCONTROLLED IF PRINTED

4. B.: Combustibles gas-in-air between 30% and 60% of the Lower Explosive Limit (3% natural gas-in-air) and oxygen level remains above 19.5%.

<u>GLOS</u>	Added new terms: Capable of Being Locked Out Casing Design MAOP Energized Hot Work Lock Out Lock Out Device LOTO System MAOP Tag Out Tag Out Device Revisions made to the following terms: Class Location Distribution Main Distribution System Director Division - replaced Division Manager Farm Tap High Pressure Distribution Main Low Pressure Main Over Pressure Protection (OPP) Permanent Repairs Regulator Station Service Line Transmission Line - Note Removed the following term NFDP - New Facility Design Pressure	Janu- ary 1, 2013	January 1, 2014
<u>INCD 0</u>	Requirements: Inserted new: INCD 1 3. Potential Significant Events Forms and Reference Materials	Janu- ary 1, 2013	January 1, 2014

Corrected dash line at Forms and Reference Materials

Forms:

Updated Form 03 - Potential Incident Report Form

Reference Materials:

Added Reference 01 - Ameren Supervisor Guidelines for Drug and Alcohol Testing

INCD 1

1. D.: Inserted new: "This procedure identifies when Ameren Illinois employees would be subjected to post-incident alcohol and drug testing."

January 1, 2013

January 1, 2014

2. Natural Gas Incident

2. A. A natural gas incident is an event that involves a release of natural gas from an Ameren Illinois facility and:

2. A.(2): "in-hospitalization" replaces "medical treatment". Now reads - Any personal injury requiring in-patient hospitalization; i.e. public, contractor, emergency responder, Ameren Illinois employee, etc.

2. A.(3): \$50,000 replaces \$25,000 for the estimated property damage cost, excluding cost of gas lost.

New section added:

3. Potential Significant Events

A. An event that does not meet the criteria of a Natural Gas Incident may be deemed to be significant in the judgment of Ameren Illinois.

B. The following events, where a release of natural gas from an Ameren Illinois facility is involved, shall be reported to Gas Compliance and will be evaluated to determine if the event should be considered to be a significant event:

(1) An explosion

(2) Any personal injury requiring medical treatment.

(3) A natural gas fueled fire with estimated property damage exceeding \$25,000.

(4) Damage to any high pressure distribution or transmission main.

(5) Damage to any distribution main with an estimated repair time in excess of eight (8) hours excluding gas service interruption relight time.

C. An event that is deemed to be a significant event shall be reported as a Natural Gas Incident.

4. Courtesy Notification

4. A.(5): Added "Potential significant events that are not deemed to be reportable as a Natural Gas Incident.

UNCONTROLLED IF PRINTED

5. Service Interruption/Curtailment Notification

5. Service Interruption/Curtailment Notification

5. A.: Replaced 500 customers with 1000 people, approximately 400 meters based upon 2.5 people per household.

6. Reporting

6. D.: Added a sentence - Gas Superintendent, Gas Supervisor, or Gas Compliance personnel shall contact Supervisor Gas Control if Gas Control personnel could be subjected to alcohol or drug testing."

8. Reporting Matrix

Separated the previous matrix into two matrix:

8. A.: Gas Compliance shall be contacted when any of the following have occurred:

The new matrix shall be reviewed with all gas employees since they only have two (2) hours after a listed event discovered to notify Gas Compliance

8. B.: Gas Compliance shall make the following report contacts:

The new matrix shall be reviewed with all gas employees since Gas Compliance only has two (2) hours after a listed event is discovered to notify the appropriate agency, ICC, PHMSA, and/or IEMA.

Updated contact information:

10. Corporate Claims Notification (CCMI)

Updated Jackie French's job title

11.: Ameren Illinois Communication Notification:

Stacey Stockton-Shangraw replaced Leigh Morris (retired)

12. Regulatory Affairs Notification

Added Robin Turner's cell phone number

13. Post-Incident Alcohol and Drug Testing

13. A.: Inserted new item: Gas Superintendent, Gas Supervisor, and/or Supervisor Gas Control should immediately contact Clinical Collection Management, Inc. (CCM) to arrange for alcohol and drug testing. To arrange for the test contact:

13. B.(1): Added "Gas Control Specialist" along with Gas Field Personnel who could be subject to Post-Incident Alcohol and Drug Testing if their performance could have contributed to the incident.

INCD 4

Forms:
Form 03 - Potential Incident Report Form

January 1, 2012
January 1, 2014

UNCONTROLLED IF PRINTED

Revised Reporting Matrix:

Inserted new column for Gas Compliance and expands the list of events that need to be reported to Gas Compliance and modifies list of events to be reported to the ICC.

Added Reference 01 - Ameren Supervisor Guidelines for Drug and Alcohol Testing

<u>LEAK</u> <u>0</u>	<p>LEAK 2.04 Leak Classification and Surveillance</p> <p>Inserted new 12. Multiple Public Leak Calls</p> <p>LEAK 4</p> <p>Updated Form 04 - Leak Survey Daily Report Form, add Form Number</p> <p>Added:</p> <p>Reference 15 - Sensit Gold G2 Manual</p> <p>Reference 16 - Heath Gasurveyor 500 Manual</p>	<p>April 1, 2013</p>	<p>January 1, 2014</p>
LEAK 2.04	<p>Leak Classification and Surveillance</p> <p>6. Uprating a Leak</p> <p>6. B.(5): Deleted "Frequency of public complaints" from the list of factors to be considered when uprating a leak. Moved public calls into a separate section.</p> <p>12. Multiple Public Leak Calls - New Item</p> <p>A. When multiple calls, three or more, are received from the public regarding a leak, the Gas Supervisor will determine the actions needed to expedite the repair of the leak and ensure that the planned repair actions are communicated to the customer, adjacent property owners or individual(s) who reported the leak.</p> <p>B. Gas Compliance will run a monthly OAS report of Multiple Leak Calls by address and distribute to Operations to assist the Gas Supervisor in identifying where three or more leak calls have been reported within a year.</p> <p>13. Repaired Leak Recheck</p> <p>13. A.(1): Inserted new item; "At the time that the below grade leak is repaired, gas field personnel shall probe into the soil around the excavation in the direction of gas facilities and obtain readings using a CGI to determine if there is a potential for additional leakage in the vicinity of the repair."</p>	<p>April 1, 2013</p>	<p>January 1, 2014</p>
LEAK 2.05	<p>Gas Leak Case Field Report</p> <p>2. A. Leak Case Information</p>	<p>April 1, 2013</p>	<p>January 1, 2014</p>

2. A.(11): Added Job Order # - used to document an associated DOJM order. This was included in the April 1, 2013 O&M changes but was left out of explanation on completing the GLFC report.

2. C. Repair Data

2. C.(3)(a): Deleted "If pressure test was not required, mark as N/A"

2. C.(3)(d): Added reference to ABND 2.01 for testing and reporting requirements when service line is abandoned.

2. C.(10): Added clarification to terms under PRESSURE since the form cannot be changed at this time.

"Distribution: System operating at 60 psig or less. Intercity: (high pressure distribution) System operating at over 60 psig and less than MAOP 20% SMYS"

2. D. Leak Recheck

2. D.: Replaced below ground with below grade.

2. D.(5): Verification Method - Deleted "mark only one box" since there is only one box to check.

2. E. Sketch Area

2. E.(1) Location: Added "Can Leave Blank" for town name where leak is found.

LEAK
2.08

Leak Surveys - Equipment

1. B.: New item inserted: "Manufacturers' manuals for instruments being utilized at Ameren Illinois are in LEAK 4.

1. C.: New item inserted: "As new leak surveying equipment is evaluated and approved by the Gas Standards group for use in Ameren Illinois territory, their manuals will be added at the next O&M update."

2. Flame Ionization Instrument = Portable

2. D.: Revise to: "Indication meter is adjusted to activate an audible alarm 10 to 20 scale points below the alarm point which should be around 35% to 50% full scale."

2. G.: Added reference to LEAK 2.13 for daily operational check.

3. Gas Detection Equipment

3. A.: Clarification that if equipped with a ppm sensor, Gas Detection Instrument can be used in place of FI unit.

3. C.: Deleted since it was a duplicate of 3.F.

3. I.: New item inserted: "If, according to the manufacturer, the instrument is designed to function as a leak surveying instrument, then the individual(s) performing leak surveys will follow the manufacturer's operating instructions. Daily operational checks should be performed in accordance with

January
1,
2013

January
1, 2014

UNCONTROLLED IF PRINTED

LEAK 2.13. If instrument is being utilized on daily basis for leak survey activity, the unit should be checked at the conclusion of the day's activity to verify the unit is still operating properly.

LEAK
2.09

Leak Surveys - Walking Leak Survey

January 1,
2013

January
1, 2014

1. Walking Leak Survey

1. A.: Revised to read: "The leak survey shall be performed with an industry recognized leak survey instrument that has been accepted for use by the Ameren Illinois Gas Standards and Procedures work group. Operation of these instruments may be based on, but not limited to; Flame Ionization, laser diode, infrared, hyperspectral imaging technology, optical methane detection, or catalytic combustion. See LEAK 4"

1. D.(5): Added "Regulator pits" to list of items that should be checked if encountered along the leak survey route.

1. K.: New section: Fenced Gas Facilities Inspected Annual

(1) Fenced gas facilities could include:

(a) Regulator Station

(b) Valve Station

(c) Pipeline Take Point

(d) Odorizer

(2) Fenced gas facilities that are inspected annually by Gas Tech Service will have all piping, below and above grade, inside the fenced area leak surveyed during the annual inspection and documented on the applicable inspection report or Leak Survey report.

(a) Fenced gas facilities associated with transmission surveys that are located in a Class 3 location will have their own designated Leak Survey since they have to be surveyed twice each calendar year not to exceed 7-1/2 months, LEAK 2.07. These leak surveys will be performed by Gas Tech Service personnel.

(b) These facilities may be shown on the leak survey maps, but they will not be part of the designated transmission or distribution leak surveys. The designated leak survey will stop at the fence.

(c) Facilities annually inspected may be identified on the maps. If there is a question, Gas Supervisor should contact Supervisor Gas Tech Services to confirm that GTS personnel are leak surveying the facility annually or if required bi-annually.

1. L.: Revised section heading to Fenced Gas Facilities Not Inspected Annually. This was the former Fenced Gas Facilities section.

- 1. L.(1): Changed to "Fenced gas facilities"
- 1. L.(2): Changed to "Fenced gas facilities"
- 1. L.(d): Added Large Meter Set is list of possible fenced facilities.
- 1. N. Gas Detection Instrument or FI Unit Indicates a Possible Leak
 - 1. N.(4)(b): Revised wording to "An OAS EMGL order will be created and qualified gas field personnel will be dispatched to the leak." Removed "Gas Supervisor will create OAS EMGL order" since there are numerous individual who create theses orders.
 - 1. N.(5): New item added: If leak surveyor detects an indication of gas from a valve box or pit which contains a gas facility. (a) Surveyor will crack the lid slightly, insert CGI probe, and obtain a sustained gas-in-air reading.
 - (b) Surveyor will check around perimeter of the box or pit for gas migration.
 - (c) Leak will be classified based on the hazard potential and volume on the Leak Classification Guidelines. See LEAK 2.04
- 1. O. Weather limitations
 - 1. O.(1)(d): Corrected reference to bullet point "F" from "E".

LEAK
2.11

Leak Survey - Records and Maps

1. Additional Survey Checks

1. C.: Added sentence "Daily Report Form is not required for fenced gas facilities that are inspected annually by Gas Tech Services. Deficiencies are recorded on the inspection report

2. Maps and Records

2. A.: Added a second sentence, "These leak surveys do not include fenced gas facilities that are inspected annually by Gas Technical Services."

2. B.: New item inserted: "Annual leak surveys performed by Gas Technical Services personnel inside fenced areas are documented on associated inspection forms or leak survey form. Maps are not required for these leak surveys."

2. E.: New item inserted, "If a facility that is annually inspected is shown on the map, the Gas Supervisor should note "annually inspected by GTS" on the map. The facility is not included in the leak survey and will not be highlighted. The transmission or distribution leak survey can be closed without these facilities being highlighted.

October 1,
2011

January 1, 2014

<u>LEAK</u> <u>4</u>	<p>Form 04 - Leak Survey Daily Report Form: added Form Number 5889NS</p> <p>Added Reference Materials</p> <p>Reference 15 - Sensit Gold G2 Manual</p> <p>Reference 16 - Heath Gasurveyor 500 Manual</p>	April 1, 2013	January 1, 2014
LOCT 0	<p>In Reference Materials added:</p> <p>Reference 22 - Radiodetection RD8000 User Guide</p> <p>Reference 23 - MADE Acoustic Gas Tracker Operation Manual</p> <p>Reference 24 - MADE Gas Tracker New Quick Start Guide</p> <p>Reference 25 - Jameson Gas Line Tracer Instruction Manual</p> <p>Reference 26 - Radiodetection RD7000 Operation Manual</p> <p>Reference 27 - Ameren Illinois Marking Standards</p> <p>Reference 28 - Fisher TW 82 Digital Line Tracer Operating Manual</p> <p>Reference 29 - 3M Dynatel 2550-2573 Operator's Manual</p>	April 1, 2013	January 1, 2014
LOCT 2.01	<p>Locating Methods</p> <p>2. Methods of Locating</p> <p>2. D.(1): "Company records" replaced "the map". "Location is marked by using the dimensions indicated on Company records."</p> <p>2. D.(2): Revised language to, "Use this method only when facilities cannot be located electronically."</p>	January 1, 2011	January 1, 2014
LOCT 2.02	<p>Equipment</p> <p>1. Locating Equipment</p> <p>Capitalized the first letter of the bullet points</p> <p>Added "and/or records" to maps as items that may be used to locate and mark underground facilities.</p> <p>2.:Electronic Locators</p> <p>2. A.: Replaced the word "pending" with "upon", "Other electronic locators may ne used upon approval."</p> <p>Updated the list of locators in the table</p>	January 1, 2011	January 1, 2014
LOCT 2.03	<p>Locate Markings</p> <p>1. B.: Revised to indicate Ameren Illinois utilizes a modified version of the Illinois State Wide Marking Guidelines. "Ameren Illinois has adopted a modified version of the Illi-</p>	October 1, 2011	January 1, 2014

nois State Wide Marking Guidelines as published by JULIE one call system. See LOCT 4"

3. Marking Flags

3. A.: Revised to "The following marking flags are stocked for use by Ameren Illinois gas field personnel. Standardized flags being stocked.

3. B.: New "Contract locators supply their own marking flags that have been approved by Damage Prevention."

4. Marking Paint

4. C.: Grammatical correction, replaced "by" with "but". "A line approximately 12" long should be sprayed on the ground surface parallel to the underground gas line. Distance between marks depends on site conditions but should be no greater than 20 feet."

4. D.: Updated marking paint stock codes

4. E.: New "Contract locators supply their own marking paint which has been approved by Damage Prevention."

LOCT
4

Added:

April 1,
2013 January
1, 2014

Reference 22 - Radiodetection RD8000 User Guide

Reference 23 - MADE Acoustic Gas Tracker Operation Manual

Reference 24 - MADE Gas Tracker New Quick Start Guide

Reference 25 - Jameson Gas Line Tracer Instruction Manual

Reference 26 - Radiodetection RD7000 Operation Manual

Reference 27 - Ameren Illinois Marking Standards

Reference 28 - Fisher TW 82 Digital Line Tracer Operating Manual

Reference 29 - 3M Dynatel 2550-2573 Operator's Manual

MAIN 1

3. Cover

April 1,
2013 January
1, 2014

3. B.: Added language about using Safety Wrap for protection of PE main. "Where the required minimum cover cannot be maintained, Safety Barrier Tape (Stock Code 16 06 958) shall be installed approximately twelve (12) inches below the surface to provide advance warning to excavators. For additional protection, Safety Wrap may be used to protect PE mains in areas where damage may occur. Safety wrap shall not be used for permanent protection of steel pipe. See DAMG 1 for Safety Wrap stock codes. Safety Barrier Tape (16 06 958) must be installed over the Safety Wrap.

3. C.: Expanded to include procedures for initiating an engineering evaluation for additional protection for shallow main and requirement for mapping locations of shallow mains.

"Additionally, mains that may be subjected to anticipated external loads, such as loaded truck traffic, material storage, or farming operations, must be reviewed to determine if additional protection is required to protect the main from damage due to the external loads. When such locations are encountered the Gas Supervisor or Contractor Services Supervisor will contact either Gas Engineer for the area if distribution main is being installed or Gas Tech Engineering if transmission or high pressure distribution is being installed. Engineering personnel will review to determine if additional protection is required and specify the appropriate protection method(s) to protect the main from the anticipated external loads. Location of shallow main should be recorded on the As-Built plans and indicate on Ameren Illinois' gas electronic mapping system."

MAIN 3.23	End of Main, Steel to Steel, Decreasing, Mueller Stopper Material Table Corrected Stock Code of 2" Steel Pipe to 32 23 319	January 1, 2011	January 1, 2014
METR 0	Table of Contents Added METR 2.23 10.: Meter Exchanges Using Portable CNG Tank METR 4: Forms and Reference Materials Update Gas Meter Data Sheet (Rev 5/13) Added: Reference 07 - Meter Guards 2 inch Posts Reference 08 - Meter Guards 4 inch Posts Reference 09 - Grunsky Portable CNG Tank and Bag Procedures	April 1, 2013	January 1, 2014
METR 1	3. Location 3. F.(3): Added information on availability of meter guards for protecting meter exposed to vehicular traffic. Two pre-fab meter guards are now being stocked. Both are 36 inches in width. One is constructed with 2 inch steel posts and cross members. The second has 4 inch posts and 2 inch cross members. 6. Painting Meter Sets 6. A.: Added reference to CORR 2.03 which includes approved paints. 6. B.: Clarified that pre-painted meters and regulators should be touched-up with approved paint if needed.	October 1, 2011	January 1, 2014

UNCONTROLLED IF PRINTED

METR 2.23	<p>Gas Meter Exchange</p> <p>Added a new section:</p> <p>10.: Meter Exchanges Using Portable CNG Tank</p> <p>Procedures for using a portable CNG tank to maintain service to customer during a meter exchange.</p> <p>Letter 3 - used if previous contacts are ignored:</p> <p>In the 4th paragraph revised so the customer is advised the meter change will be scheduled "on or after" a specific date.</p>	October 1, 2011	January 1, 2014
METR 2.24	<p>Replacement of Large Volume Diaphragm Meters</p> <p>1. General</p> <p>1. A.: Deleted this sentence since it really didn't fit.</p> <p>3. Inspecting Customer Piping and Appliances</p> <p>3. B.: Grammatical correction for " a Warning tag"</p> <p>8. Changing Correcting Devices</p> <p>8. A.: Added reference METR 2.16 for the Gas Meter Data Sheet.</p> <p>13. Reporting</p> <p>Separated language for OAS orders and Gas Meter Data Sheet.</p> <p>13. A.: Appropriate OAS orders shall be completed.</p> <p>13. B.: A Gas Meter Data Sheet, when applicable under item 8. of this part, shall be completed and distributed. See METR 2.16</p>	July 1, 2012	January 1, 2014
METR 3.14	<p>425 Meter, By-Pass, 2, 5, 10, psig Delivery Pressure, 5 - 60 psig Inlet</p> <p>Added Stock Code 62 54 423 for 1" x 1-1/4" Meter Bar, AL 425, with By-Pass, 30LT nuts, 1-1/4" union outlet</p>	April 1, 2013	January 1, 2014
METR 3.17	<p>630 Meter, By-Pass, 2, 5, 10, psig Delivery Pressure, 5 - 60 psig Inlet</p> <p>Added Stock Code 62 54 422 for 1" x 1-1/4" Meter Bar, AC 630, with By-Pass, 45LT nuts, 1-1/4" union outlet</p>	April 1, 2013	January 1, 2014
METR 3.18	<p>Multiple Meter Installation</p> <p>Added Multimeter Headers for 4 meter and 6 meter for 175/250 and 425 meter installations.</p> <p>62 04 321 - 1-1/4" x 48" for 4 meters</p>	April 1, 2013	January 1, 2014

62 04 323 - 1-1/4" x 72" for 6 meters

METR 4	<p>Form 03 - Gas Meter Data Sheet (Rev 5/13)</p> <p>Page 2 has the removal information but there were two locations that initially had "Date Installed". These were changed to "Date Removed". Form was revised in May 2013 and is already in print.</p> <p>Reference 07 - Meter Guards 2 inch Posts</p> <p>Reference 08 - Meter Guards 4 inch Posts</p> <p>Reference 09 - Grunsky Portable CNG Tank and Bag Procedures</p>	January 1, 2013	January 1, 2014
ODOR 2.02	<p>Odorization Operation</p> <p>4. Odorization Operation and Inspection</p> <p>4. E.: Revised language to include all odorizers and added formula for calculating the odorant usage rate, LBS/MMCF.</p> <p>"Supervisor Technical Services or Gas Engineer shall conduct an annual review of odorant injection rates, by-pass rates, and actual quantities of odorant consumed at each odorizer installation. This review will ensure adequate odorization and provide documentation that each odorizer site is configured, adjusted, operating properly and has provided the prescribed odorant-to-gas ratio specific to that site. The actual odorant usage is calculated by measuring the odorant utilized and dividing by the corrected volume of gas during the period."</p> <p>4. E. Note: Grammatical change "Volume of odorant and gas that is utilized during the review period."</p> <p>5. Liquid Odorant Tank to Tank Transfer</p> <p>5. A." Grammatical change "As Safety is the first priority, the following safe practices should be observed:"</p>	January 1, 2013	January 1, 2014
ODOR 2.05	<p>Odorant Intensity Testing Flowchart</p> <p>2.: Revised language on Readily Detectable Level to match the language in ODOR 2.03. Previous language was confusing.</p>	January 1, 2013	January 1, 2014
PMRK 1	<p>2.: Placement</p> <p>2. C.: Added "Consideration should be given to installing pipeline marker at farm taps located in areas where vegetation growth may inhibit visibility."</p> <p>3. Line Marker Warning</p> <p>Third bullet point added Ameren Illinois and 1-800-755-5000</p>	January 1, 2012	January 1, 2014

PMRK 3.01	<p>COTT Pipeline Markers</p> <p>1. B.: Added language about calling JULIE, "If the location of the pipeline marker is not covered under a valid JULIE Dig Number for Ameren Illinois, call 811 to obtain a valid dig number before installing the pipeline marker(s)."</p> <p>3. Installation</p> <p>3. F.: New "In areas where the marker posts are susceptible to damage by such activities as mowing, agricultural operation or construction activities, a COTT marker can be placed over a steel post. Installation procedure will deviate from that shown above since the COTT marker would not need to be set 2' to 3' in the ground and the use of the flexible plastic anchor would not be possible."</p>	July 1, 2012	January 1, 2014
PMRK 3.02	<p>Carsonite Pipeline Markers</p> <p>1. B.: Added language about calling JULIE, "If the location of the pipeline marker is not covered under a valid JULIE Dig Number for Ameren Illinois, call 811 to obtain a valid dig number before installing the pipeline marker(s)."</p>	April 1, 2013	January 1, 2014
PMRK 3.03	<p>Regulator Stations</p> <p>3. Danger Sign - Stock Code 16 02 285</p> <p>Added the word "Natural" to current sign. Current sign remains a valid sign posted at regulator stations and does not need to be changed until the condition dictates replacement. Once current supply is depleted the new sign will be the replacement stock.</p>	Octo- ber 1, 2011	January 1, 2014
POLY 1	<p>8. Weak Link</p> <p>8. B.(1): For PE pipe sizes less than or equal to 1" CTS</p> <p>8. B.(1)(a): Deleted scoring PE pipe as an acceptable way to create a weak link.</p> <p>8. B.(1)(b): Added "Install a weak link made from a short section of PE pipe one nominal pipe size less than the size being installed and approximately eighteen (18) inches in length; ½" CTS weak link for 1" CTS pipe. The PE pipe must be of the same or lesser density as the pipe being pulled in."</p> <p>8. B.(1)(c): Added "Boring rods that are one (1) inch, or more, larger in diameter than pipe being installed can take the place of a pull plug when the PE pipe is being pulled in behind the boring rods.."</p> <p>8. B.(2): For PE pipe sizes larger than 1"CTS</p> <p>8. B.(2)(a): Deleted scoring PE pipe as an acceptable way to create a weak link.</p>	April 1, 2013	January 1, 2013

8. B.(2)(a): Added language regarding weak link made from one pipe size smaller must be of the same PE pipe density. "The PE pipe must be of the same or lesser density as the pipe being pulled in. MDPE weak link is only acceptable when pulling in MDPE pipe. HDPE weak link is only acceptable when pulling in HDPE pipe."

8. B.(2)(b): Added "Boring rods that are one (1) inch, or more, larger in diameter than pipe being installed can take the place of a pull plug when the PE pipe is being pulled in behind the boring rods.."

POLY 2.05	Electrofusion 1. F.: Added language regarding Friatec and Innogaz fittings. "In the April 1, 2013 O&M Plan, electrofusion fittings shown in the Standard Design sections for MAIN and SERV were primarily Central Plastic products due to the Company's decision to go to a single source provider. However, the formerly stock coded Friatec and Innogaz electrofusion fittings remain approved and can be used until the supply has been depleted. If there is a supply issue with Central Plastic not being able to fill orders in a timely manner, Ameren Illinois will order needed fittings from Friatec and/or Innogaz."	April 1, 2013	January 1, 2014
POLY 2.08	Sale of Polyethylene Pipe 2.: Request from the Public 2. B.: Division Director replaces District/Regional Manager	January 1, 2011	January 1, 2014
POLY 3.02	Electrofusion Fittings Added a Note at the end of the section, "Note: Since Ameren Illinois has gone to single source provider, majority of the fittings listed above are Central Plastic's fittings. However, the formerly stock coded Friatec and Innogaz electrofusion fittings remain approved and can be used until the supply has been depleted. If there is a supply issue with Central Plastic not being able to fill orders in a timely manner, Ameren Illinois will order needed fittings from Friatec and/or Innogaz."	April 1, 2013	January 1, 2014
PRES 0	Added PRES 2.06 Pressure Change Request to Pipeline Supplier PRES 4 Added a new Form: Ameren Pressure Change Request	January 1, 2013	January 1, 2014
PRES 2.04	Overpressure Reporting 1. D.: Managing Supervisor Operations - Gas Training and Quality Assurance replaces Manager Gas Compliance	October 1, 2011	January 1, 2014

PRES 2.06	<p>Pressure Change Request to Pipeline Supplier</p> <p>New procedure is a formal process when Ameren Illinois needs for a Pipeline Supplier to change delivery pressure into an Ameren Illinois gas system. Process is for both temporary and permanent changes. A request form must be completed, submitted to, and approved by the Superintendent Gas Technical Services. Gas Technical Service personnel will coordinate review, evaluation of the requested change and submittal to the Pipeline Supplier. Procedure includes a workflow diagram on how a change request is processed.</p>	N/A	January 1, 2014
PRES 4	<p>Forms and Reference Materials</p> <p>Added a new Form: Ameren Pressure Change Request</p>	January 1, 2013	January 1, 2014
PTST 1	<p>2. Test Medium</p> <p>2. A.: Deleted the restriction for using natural gas for up-rates only. PHMSA allows natural gas as an acceptable test medium.</p> <p>3. Test Recording Methods</p> <p>Process Pressure Gauges Table</p> <p>Retitled the Ashcroft 1279A heading to "Grade 2A, ± 0.5% Full Scale Accuracy, Black Plastic Case, 4-1/2" Face"</p> <p>Stock Codes and pressure ranges for these process gauges has been completely revised and updated in EM-PRV. Currently, EM-PRV has Ashcroft and McDaniel as approved manufacturers. Additional manufacturers can be added when approved.</p> <p>4. Testing</p> <p>4. A. New: "PE and Steel distribution service lines smaller than two (2) inches shall be tested at the following minimum pressures for the minimum duration specified in PTST 2.01:</p> <p>(1) 90 psig for service lines on systems operating at or below a Design MAOP of 60 psig</p> <p>(2) 150 psig for service lines on systems operating at or below a Design MAOP of 100 psig but more than 60 psig</p> <p>(3) For service lines on systems operating over 100 psig but less than 20% SMYS the test pressure is 1.5 times the Design MAOP. If the test pressure on the service line exceeds 20% SMYS of the pipe, it is to be tested in accordance with "D." below. Table lists test pressure that would reach 20% SMYS for steel service lines smaller than 2 inches."</p> <p>4. D.(4): Revised wording to clarify "For any pipeline that requires a separate leak and strength test but will operate at less than 30% SMYS, additional test medium can be</p>	April 1, 2013	January 1, 2014

added to raise the test pressure to at least 1.5 time the planned MAOP. This is a strength test with minimum duration of at least one (1) hour."

9. Test Records

9. A.(1): Added a sentence, "This stamp is being revised so future plans may have a different stamp."

9. A.(3): Added the draft of a new Leak & Strength Test Stamp that will be used projects designed by Gas Tech Engineering.

PTST
2.01

Leak Test

1. B.: Gas Tech Engineering replaced Gas Operations and Services

2. Test Medium

2. A.: Deleted the restriction for using natural gas for up-rates only. PHMSA allows natural gas as an acceptable test medium.

3. Leak Test Duration

3. C.: Gas Tech Engineering replaced Gas Operations and Services - Engineering

3. D.: New: "When testing main segments of various sizes as a single test, the test duration should be determined by the largest diameter of pipe and the length of the entire section of pipe being tested."

4. Leak Test Procedures

4. F.: "bleed of test medium" replaced "bleed off air, nitrogen, or water used as the test medium"

5. Leak Test Records

5. A.: Added reference to PTST 1

5. B.(8): Grammatical, deleted the word "and"

5. D.: Grammatical, deleted an extra "life" in the sentence.

PTST
2.03

Hydrostatic Pressure Testing

1. B.: Gas Tech Engineering replaces Gas Operations and Services - Engineering

2. A.: Gas Tech Engineering replaces Gas Operations and Services - Engineering

2. C.: Gas Tech Engineering replaces Gas Operations and Services - Engineering

3. A.: Gas Tech Engineering replaces Gas Operations and Services - Engineering

January 1,
2013

January 1, 2014

3. C.: Revised to "Ameren Illinois or contractor personnel required to perform the test should be knowledgeable and experienced and qualified in hydrostatic testing procedures including discharge of test water." Deleted the reference to Ameren's OQ course designation.

4. C.: Gas Tech Engineering replaces Gas Operations and Services - Engineering

PUBL 1	1. A.(3): Ameren Illinois replaced Ameren Illinois Utilities	June 1, 2010	January 1, 2014
PUBL 2.01	Public Notifications 4. Pipeline Emergency Response Notifications to Government Organizations 4. D.: Added reference to PUBL 2.02 for annual notification letter. 6. Records 6. A.: Revised wording, "Ameren Illinois Public Awareness Group shall maintain a copy of the annual notification letter sent to government organizations. File is maintained at the Gas Compliance office." 6. C.: Revised wording, "Ameren Illinois Public Awareness personnel will maintain a list of face-to-face visits through NIPA/SIPA meeting and public education programs. File is maintained at the Gas Compliance office." 6. D.: Revised wording, "Ameren Illinois Public Awareness personnel will maintain a copy of the one-call program's notification programs File is maintained at the Gas Compliance office." 6. E.: New item; "Ameren Illinois Public Awareness personnel will maintain lists of Emergency Responder training for fire, police, and other emergency agencies which includes: dates, locations, topics and list of attendees. This information is filed at the Gas Compliance office."	Janu- ary 1, 2013	January 1, 2014
PUBL 2.02	Liaisons with Public Officials 5. Natural Gas Emergency Procedures 5. (2)(g): Updated Ameren Illinois phone number, 1-800-755-5000, that the general public would use to call in a gas emergency.	Janu- ary 1, 2011	January 1, 2014
QUAL 4	Updated Leak Survey - QA1005 form Numerous changes were made to this QA Field Inspection checklist. Revisions were based on field observations that identified a need to expand the tasks associated with leak surveying.	Janu- ary 1, 2012	January 1, 2014

REGS 0	<p>Table of Contents</p> <p>Eliminated REGS 2.02 Primary Inspection.</p>	April 1, 2013	January 1, 2014
REGS 1	<p>Regulator Stations</p> <p>2. Regulator Station Inspection Schedule</p> <p>2. A.(1): Added Supervisor Gas Tech Services as one who is responsible for ensuring annual inspection is completed.</p> <p>2. C.: Added Supervisor Gas Tech Services as one that has discretion if a Primary Inspection should be performed on a more frequent interval than once every 10 years.</p> <p>2. D.: Added Supervisor Gas Tech Services as one that has discretion of identifying regulator stations that require a more frequent inspection than annually.</p> <p>3. B.: Gas Tech Engineering replaces Gas Operations and Services - Engineering</p>	January 1, 2011	January 1, 2014
REGS 2.01	<p>Regulator Station Inspections - Name change from Operational Inspection</p> <p>Primarily affects Gas Tech Services personnel who perform regulator station inspections.</p> <p>This entire section has been totally rewritten by Gas Tech Services personnel and now contains the procedures for both Operational and Primary Inspections. Operational inspection procedures have been greatly expanded to address the various regulator station configurations.</p> <p>Supervisors - Gas Tech Services will be reviewing this section with their technicians.</p>	July 1, 2012	January 1, 2014
REGS 2.02	<p>Primary Inspection</p> <p>This section is being eliminated since Primary Inspection has been added to REGS 2.01.</p>	April 1, 2010	RE- MOVED January 1, 2014
REPR 0	<p>Corrected dash line at REPR 3.02</p> <p>Added REPR 4 Forms and Reference Materials</p> <p>Added:</p> <p>Reference 01 - Syntho Glass XT Installation Guidelines</p> <p>Reference 02 - Syntho Glass XT Engineering Assessment Form</p>	January 1, 2012	January 1, 2014
REPR 1	<p>4. Steel Pipe Repair</p> <p>4. J.(5): Added new item: "If composite wrap is determined to be the appropriate repair method then Syntho-Glass XT, manufactured by Neptune Research, shall be used. See REPR 4 for installation guidelines. Before another brand of</p>	January 1, 2013	January 1, 2014

UNCONTROLLED IF PRINTED

composite wrap is used, it must be approved by Gas Standards group in coordination with Corrosion and Gas Tech Engineering groups"

4. J.(6): Added new item: "Syntho-Glass XT can be purchased through Technical Engineering Sales (815-600-2808)."

4. J.(7): Added new item: "Technical Engineering Sales personnel shall provide assistance with material, training and qualification requirements. See REPR 4 for an engineering assessment form which contains information Technical Engineering Sales personnel will need."

10 Repair Records

10.C. Mapping

10. C.(1): Replaced FRAMME with "electronic mapping system".

10. C.(2): Replaced FRAMME with "electronic mapping system".

REPR 2.01

Compression Couplings

2. Main Repair Methods for Compression Couplings

2. A. & B. Grammatical, added the work "and"

2. C. Steel to Steel

2. C.(1): Added three ways one may be able to determine if the pipe has slipped inside the coupling, pull out.

2. C.(1)(a): Wrap shows evidence of being stretched.

2. C.(1)(b): Pipe shows evidence of being pulled or is out of normal alignment with coupling.

2. C.(1)(c): Once wrap is removed, pipe next to coupling is cleaner or shiner than the rest of the pipe.

2. C.(2)(a): Added "at time of the leak repair" so this now reads, If pull out is detected, "Tighten and encapsulate the compression coupling with full encirclement welded split sleeve at the time of the leak repair or

Remove the coupling and replace with a new section of pipe connected by an approved welding procedure in order to eliminate the leak."

2. C.(3)(a): Grammatical, added the work "and"

3. Service Line Repair Methods for Compression Couplings

3. A. Plastic to Plastic

3. A.(1): Grammatical, added the work "and"

3. B.(1): Replaced "should" with "shall": "If the steel portion of the service line is isolated from the cathodic protection system, the service line shall be replaced."

UNCONTROLLED IF PRINTED

3. C. Steel to Steel

To eliminate confusion as to the repair method for compression couplings within 5 feet of a foundation wall, this is now a separate item.

3. C.(1): "If the compression coupling is within 5 feet of a foundation wall:

(a) Replace the service line or

(b) Tighten and encapsulate the compression coupling with a full encirclement welded split sleeve or

(c) Remove the coupling and replace with a new section of pipe connected by an approved welding procedure."

3. C.(2): "If the compression coupling is greater than 5 feet from a foundation wall, visually inspect for pull out of the pipe from the compression coupling:

(a) If pull out is detected: See REPR 2.01 2. C.(1) above

- Replace the service line or
- Tighten and encapsulate the compression coupling with a full encirclement welded split sleeve, or
- Remove the coupling and replace with a new section of pipe connected by an approved welding procedure.

(b) If pull out is not detected:

- The compression coupling may be tightened to repair the leak and
- The Gas Supervisor shall create a DOJM to replace the service, to encapsulate the compression coupling with a full encirclement welded split sleeve or remove the coupling and replace with a new section of pipe connected by an approved welding procedure. The DOJM shall be completed within 30 days

4. Compression Joints on Steel Tees and Valves

Compression joint within 5 feet of foundation is a separate item now.

4. A.: If the compression joint tee or valve is within 5 feet of a foundation wall:

(1) Replace the tee or valve or

(2) If leak is eliminated, install welded straps across the joint, equally spaced around the joint, minimum of two (2) straps, See REPR 3.05, and

(3) Remove the tee or valve and replace with a new section of pipe, tee, or valve connected by an approved welding procedure, within 30 days.

4. B.: "If the compression joint tee or valve is greater than 5 feet of a foundation wall, visually inspect for pull out of the pipe from the compression joint.

(1) If pull out is detected: See REPR 2.01 2. C.(1) above

(a) Tighten the compression joint.

(b) If leak is eliminated, install welded straps across the joint, equally spaced around the joint, minimum of two (2) straps, See REPR 3.05, and

(c) Schedule the replacement of the tee or valve with a weld-in section of pipe, tee, or valve within 30 days. Gas Supervisor shall create a DOJM to replace the compression joint. DOJM shall be completed within 30 days.

(d) If leak is not eliminated replace the tee or valve with a section of pipe, tee, or valve connected by an approved welding procedure.

(2) If pull out is not detected:

(a) Tighten the compression joint to eliminate the leak.

(b) Following the repair by tightening, the Gas Supervisor shall identify if that section of main is scheduled for replacement within the next 36 months as part of a coupled steel main replacement program.

(c) If not scheduled for replacement, the Gas Supervisor shall create a DOJM to replace the compression joint with a new section of pipe, tee, or valve connected by an approved welding procedure. The DOJM shall be completed within 30 days.

REPR 4	Forms and Reference Materials Added two references Reference 01 - Syntho Glass XT Installation Guidelines Reference 02 - Syntho Glass XT Engineering Assessment Form		January 1, 2014
SECR 2.01	Communicating Security Threats 3. B.: Director for replaces Manager 4.: Director for replaces Manager	Janu- ary 1, 2013	January 1, 2014
SECR 2.02	Critical Gas Facility Security Measures Director for replaces Manager in several sections of this document	April 1, 2013	January 1, 2014
SERV 0	Table of Contents Added SERV 2.07 Gas Service G/Tech Mapping	April 1, 2013	January 1, 2014

SERV 1	<p>2. Depth</p> <p>2. B.(c): Inserted new item: "Safety Wrap may be used for permanent protection of PE pipe. See DAMG 1 for stock codes. Safety Barrier Tape (16 06 958) must also be installed over the Safety Wrap."</p> <p>5. Location</p> <p>5. D.(3): Deleted "See Exhibit 3" for fire escape since it was not applicable</p> <p>8. PE Service Lines</p> <p>8. F.: Increased minimum thickness to 6 inch of rock free soil to cover PE pipe as a protection against damage from rocks or other abrasive backfill material.</p> <p>13 Records</p> <p>13. D.: New item: "Gas services shall be mapped in the Ameren Illinois electronic mapping system. See SERV 2.07"</p>	April 1, 2013	January 1, 2014
SERV 2.02	<p>Excess Flow Valves</p> <p>3. EFV Sizing</p> <p>3. C.: Inserted new item; "Any proposed 1/2" service that may at any point have an inlet pressure of less than 20 psig should be upgraded to a 1" service and EFV."</p> <p>3. E.(1): Table for 1/2" PE service lines: Deleted values for inlet pressures 10 and 15 psig. 1/2 inch EFV's with inlet pressures below 20 psig do not have flow capacity to support a standard residential gas meter.</p>	April 1, 2013	January 1, 2014
SERV 2.04	<p>Yardlines</p> <p>4. Yardline Installation</p> <p>Reformatted by adding bullet points for the previous text.</p> <p>4. A.: Revised wording to "Yardlines are required to be leak surveyed more frequently which requires additional operating and maintenance resources."</p> <p>4. B.: Revised wording to "Yardlines have the potential to develop corrosion leaks or being damaged by excavation."</p> <p>4. C.: Revised wording to "For these reasons, Ameren Illinois will maintain a new service installation policy that requires all new residential meter sets to be installed within three (3) feet of the building, including manufactured homes and multiple unit buildings, which will avoid the creation of new yardlines."</p>	Janu- ary 1, 2011	January 1, 2014
SERV 2.06	<p>Gas Service Transaction Card</p> <p>3. Distribution</p>	April 1, 2013	January 1, 2014

3. B.: Inserted new item: "A copy of the completed Gas Service Transaction card shall be forwarded to the appropriate poster for entering on the electronic mapping system. This can be done electronically."

SERV 2.07	NEW: Gas Service G/Tech Mapping Provide standardization on how services are to be mapped in G/Tech.		January 1, 2014
SERV 3.06	Farm Tap - Single Cut 60 - 450 PSIG Revised G3511## Material List. Eliminated the material for a 1/2" service line installation since all farm tap services will now be a minimum of 1" CTS.	April 1, 2013	January 1, 2014
SERV 3.07	Farm Tap - Double Cut 451 - 1000 PSIG Revised G3531## Material List. Eliminated the material for a 1/2" service line installation since all farm tap services will now be a minimum of 1" CTS.	April 1, 2013	January 1, 2014
STLP 0	Table of Contents 2.01 Design Pressure Added 6. Dual Coat Steel Pipe	Janu- ary 1, 2013	January 1, 2014
STLP 2.01	Steel Pipe Design Pressure 5. Table: Corrected the Design Pressure values for the 14 inch Schedule 40 pipe. The values for the Schedule 10 had been copied to the Schedule 40. 6. Dual Coat Steel Pipe - New Section Stock Codes have been set up for 2", 4", 6", and 8" Steel Pipe, Schedule 40, Double Random Length. Pipe will have an average of 14 mil FBE and a minimum of 20 mil ARO coating. Table provides pipe information and design pressures.	Janu- ary 1, 2013	January 1, 2014
STLP 3.02	Reinforcing Saddles 1. D. Table: In the Note replaced Gas Engineering or Gas Operations and Services with Gas Tech Engineering. 1. E.: New: "Weldolets that meet ASME B31.8 requirements for reinforcement area is an approved substituted for both a regular and a full encirclement reinforcing saddle for all pressure ranges and all sizes and ratios of header and branches. (1) Weldolets are designed so that they have enough area in the fitting itself to meet the requirements for	Janu- ary 1, 2011	January 1, 2014

extra reinforcement area that is not provided by the branch and header pipe walls.

(2) Weldolets must be selected according to the specifications and requirements set forth in the manufacturer's catalog.

(3) Weldolets may also be used on branches that do not require additional reinforcement as their shape allows for more efficient fluid flow

TAPS 0	<p>Table of Contents</p> <p>Inserted new item in TAPS 1</p> <p>7. Gauge, Blow-down, By-pass Fittings</p> <p>TAPS 4 Forms and Reference Materials</p> <p>Added:</p> <p>Reference 21. Mueller Autoperf Installation Instructions</p>	Janu- ary 1, 2013	January 1, 2014
TAPS 1	<p>1. H.: Inserted new item: "Qualified Individual shall be present while the tapping machine is being assembled, installed, tested and during drilling operations."</p> <p>1. I.: Inserted new item: "Qualified Individual shall be present while the stopping equipment is being assembled, installed, tested and during stopping operations. This Qualified Individual should remain with stopping equipment until such time that pressure variations being monitored are shown to be satisfactory."</p> <p>1. J.: Inserted new item: "Under no circumstances should an open ended pipeline be left unattended while stopping equipment is in operation. Pipe ends shall have an approved weld cap rated for the pipeline pressure installed at the end of each day so that the stopping equipment can be raised, tapping valve closed and equipment left unattended overnight. Caps shall be installed utilizing an approved welding procedure."</p> <p>1. K.: Inserted new item: "When a valve is being utilized to isolate the pipeline, the open ends shall be capped as outlined above."</p> <p>3. B.: Supervisor Gas Tech Services replaces Gas Operations and Services - Technical Services Supervisor</p> <p>3. E. & F.: Gas Tech Engineer replaces Gas Operations & Services - Engineer</p> <p>New 7. Gauge, Blow-down, By-pass Fittings:</p> <p>A. When installing fittings to facilitate tapping and stopping operations consideration should be taken as to the potential need to reuse these fitting in the future. Items to be considered are:</p>	Janu- ary 1, 2013	January 1, 2014

- (1) Purpose of installed control fitting
- (2) Possible need to use control fitting to isolate main segment in an emergency situation
- (3) Location of mainline valves that could be used to isolate main segment
- (4) Accessibility of control fitting
- (5) Potential need for relocating main segment

B. Tapping and stopping operations on pipelines with MAOP over 60 psig may require installation of fittings to be used for a gauge tap, blow-down and/or by-pass. (1) Valve tees, save-a-valve nipple, or other approved fitting shall be used on transmission and high pressured distribution pipeline. Service style tee with an internal cutter/punch assembly shall not be used for gauge taps, blow-downs or by-pass on these mains.

(2) Following completion of the tapping and stopping operations, the valve tee outlet can be capped with a threaded steel cap/plug or a weld cap/plug. The cap/plug shall be leak tested with leak detection fluid.

(3) The valve tee shall be left in the closed position.

C. Tapping and stopping operations on distribution pipelines with MAOP of 60 psig and lower may require installation of fittings to be used for gauge tap, blow-down and/or by-pass. (1) Service tee with an internal cutter/punch assembly is an acceptable fitting along with those listed in 7. B.(1) above.

(2) Following completion of the tapping and stopping operations, fitting outlet can be capped with a threaded steel cap/plug or a weld cap/plug. The cap/plug shall be leak tested with soap.

(3) The punch can be left in the down position. D. The fitting shall be pressure tested in accordance with PTST 1 prior to tapping.

TAPS 3.01	Mueller Fittings 4. Mueller Bottom-Out Line Stopper Fittngs Added 1-1/4" H-17085 19 33 042, not in Mueller catalog any longer but is available.	Janu- ary 1, 2011	January 1, 2014
TAPS 4	Forms and Reference Materials Added: Reference 21 - Mueller Autoperf Tee Installation Instructions	Janu- ary 1, 2013	January 1, 2014

TURN 2.11	<p>Warning Tag</p> <p>4. Isolating an Appliance</p> <p>Revised language regarding locking off meter valve.</p> <p>4. B.: "Gas field personnel may shut-off the meter valve, disconnect and cap the meter set outlet. The meter valve is not required to be locked since the meter set is disconnected from customer piping. The customer or HVAC /plumbing contractor may reconnect the piping and relight the appliance(s) or"</p> <p>4. C.: "If the hazard is isolated at the meter valve, then the valve shall be locked and gas field personnel should follow up to unlock the valve so customer or HVAC /plumbing contractor can relight the appliance(s)."</p> <p>5. Code Violations</p> <p>5. C.(6): Added requirement to provide customer or their representative with the Warning Tag if not installed on piping or appliance. "Install the "Warning" tag on the piping or appliance or provide to the customer or their representative. The original is retained by Ameren Illinois and filed for future reference."</p> <p>5. D. Examples of Code Violations</p> <p>Deleted the note: "Note: All code violations shall be corrected before gas is turned on to a new structure or newly installed appliance(s)."</p> <p>6. Hazardous Conditions</p> <p>6. C.(6): Added requirement to provide customer or their representative with the Warning Tag if not installed on piping or appliance. "Install the "Warning" tag on the piping or appliance or provide to the customer or their representative</p>	January 1, 2013	January 1, 2014
VALV 1	<p>1. Replace "all" with "new". "This section provides information for the placement and inspection of emergency valves and the installation of new valves within the Ameren Illinois gas systems."</p> <p>2. Design Consideration</p> <p>2. A.: Grammatical change, made systems plural.</p> <p>2. B.: Revised language to: Intended valve function (emergency, non-emergency, isolation, blow-down) and desired accessibility (i.e. not in bottom of ditch if at all possible), including avoiding excessive depths."</p> <p>2. C.: Deleted "One hundred percent isolation of a system or any portion thereof."</p> <p>2. E.: Added Gas Tech Engineering designate other situations where a valve needed installed.</p>	July 1, 2012	January 1, 2014

3. Emergency Valve - Location

3. B.: Removed (>60psig) and (≤60psig) from high pressure distribution and distribution.

3. C.: Added "flow control stations" which should have a valve installed at a safe distance from the station.

3. D.: Cleaned up language to: "All emergency valves including blow-down valves are to be entered into Ameren Illinois electronic mapping system. System maps will distinguish these valves as Emergency Valves along with their respective Valve ID #."

3. E.: Cleaned up language to: All emergency valves including blow-down valves are to be entered in Gas Compliance System with the same Valve ID# as that shown in the electronic mapping system."

4. Emergency Valve Inspection

4. C.: Revised to "Any new valve box installation must include a lid marked "GAS"

VALV
2.01

Valve Installation

2. Valve Identification

2. A.: Clarified that the valve ID's are entered on the electronic mapping system.

3. Emergency Line Valves

3. B.: Removed the (MAOP > 60psig) and (MAOP ≤ 60psig)

3. B.(1): Added Gas Tech Engineering as another group that can designate distribution valve as an emergency valve.

3. B.(3): Revise wording on outage zones to: "Zones of Isolation (Outage Zones) should be established to support effective re-lights and emergency management. The size of the zone should be such that the majority of affected customers can have service restored within 24 hours."

4. Emergency Station Valves

4. A.(2): Combined the previous 4. A.(6) into this item by adding "newly installed or newly designated" stations that must have an emergency/fire valve installed.

4. A.(4): Inserted new item that clarifies a safe distance. "A safe distance is generally accepted as being 25 feet of more from the pressure control or flow control station."

4. A. (6): Deleted the previous item (6), moved into item (2) above.

4. C.: Rebuilt Station Defined

4. C.(3)(c) & (i): Clarified what is not considered a "rebuild" when regulator, springs, orifice, liners, or ports are changed

January 1,
2013

January 1,
2014

at a regulator station. As long as the purpose for the change is not to increase or decrease station capacity it is considered a maintenance activity and not a station rebuild.

5. Non-Emergency Valves

Throughout this section "GCS" replaces "Gas Code Compliance system "

5. B.: Grammatical revisions: The valve could be used to aid in the sectionalizing or isolating areas of the system in cases requiring the shut-down of gas for reasons such as:

- (1) Damage to a gas main
- (2) Gas main replacement or relocation project
- (3) Uprating a section of the system

5. C.: Added Gas Tech Engineering as another group who could determine location of an emergency valve.

5. D.: Revised mapping system designation to "gas electronic mapping system".

5. E.(1): Grammatical revision; "Be cautious when entering a valve in GCS that the correct Designation is checked and an Emergency Valve is not erroneously entered as Non-Emergency."

5. F.: Clarified when a non-emergency valve is to be classified as an emergency valve. "If a below grade non-emergency valve is used to isolate or sectionalize gas main segments of a gas distribution system or transmission system during an emergency situation, the valve will be designated as an Emergency Valve after the emergency situation has been resolved. An Emergency Valve ID shall be assigned. The valve shall be entered into the GCS and on the electronic gas system map. In the Remarks section of the Valve module in GCS, enter "valve was used during an emergency situation". This does not include a below grade service line valve used to shut down a service line."

WELD
1

1. B.: Added "regulations and codes" so now reads: "All company and contractor personnel performing work for the company shall follow the specifications, procedures, regulations, and codes presented herein."

January 1, 2013

January 1, 2014

1. C.: Inserted new item: "Ameren Illinois will follow the latest edition of regulations and codes that have been adopted by reference in Part 192."

4. Limitation on Welders

Replaced API 1104 section numbers with title of the section in the following:

4. C.: "A welder may not weld on pipe to be operated at a pressure that produces a hoop stress of 20% or more of SMYS unless within the preceding 6 calendar months the welder has had one weld tested and found acceptable un-

der Qualification of Welders or Acceptance Standards for Nondestructive Testing section of API 1104."

4. D.: "Welders may maintain an ongoing qualification status by performing welds tested and found acceptable under Qualification of Welders or Acceptance Standards for Nondestructive Testing section of API 1104 at least twice each calendar year, but not at intervals exceeding 7-1/2 months."

6. Inspection and Testing of Welds

6. C.: "The acceptability of a weld that is nondestructively tested or visually inspected is determined according to the standards in Acceptance Standards for Nondestructive Testing section of API Standard 1104. However, if a girth weld is unacceptable under those standards for a reason other than a crack, and if Appendix A to API 1104 applies to the weld, the acceptability of the weld may be further determined under that appendix. Contact Ameren Illinois Gas Training Center if assistance is needed to determine the acceptability of the weld."

7. Nondestructive Testing

7. C.: "API 1104 "Acceptance Standard for Nondestructive Testing section" will be used for proper interpretation of each nondestructive test to ensure the acceptability of the weld."

7. F.: Replaced the reference to "item 6 above" with the title of item 6, Inspection and Test of Welds.

WELD 2.01	<p>Safe Welding Practices</p> <p>1.: Deleted the sentence "He/she shall designate precautions to be followed in granting authorization to proceed, in the form of a "Hot Work" permit or noted on Job Briefing, JBO, when necessary.</p> <p>2. Prohibited Areas</p> <p>2. A.(3): Replaced 20% LEL with 30% LEL above which cutting and welding would be prohibited.</p> <p>8. Protection of Personnel</p> <p>8. B. Eye Protection</p> <p>8. B.(1)(g): For booths and screens replaced comply with section 3.5 with Welding Screens and Booths of this part.</p>	Janu- ary 1, 2012	January 1, 2014
WELD 2.02	<p>Welder Performance Qualifications</p> <p>2. Standards and Codes</p> <p>Replaced "latest approved edition" with "latest adopted editions" for the various codes referenced in Part 192.</p> <p>2. A.: Added the abbreviation of (PHMSA Part 192) for Department of Transportation, Code of Federal Regulations,</p>	July 1,2012	January 1, 2014

Title 49, Part 192, "Transportation of Natural and Other Gas by Pipelines."

2. C.: Corrected the title of American Petroleum Institute (API) 1104 Appendix B to "In-Service Welding".

5. Qualification Categories (Initial Test)

5. B. Ameren Illinois Qualification Categories

5. B.(1) Pipeline - (Single): Replaced DOT 192 with PHMSA Part 192.

5. B.(2) Pipeline - (Multiple): Replaced DOT 192 with PHMSA Part 192

5. B.(3) Maintenance: Added "In-Service Welding" as title to API 1104 Appendix B.

5. C. Pipeline - Single Qualification (Butt/Branch welds) (on nominal pipe Diameters)

5. C.(1): Replace API 1104, Section 6.0, Paragraph 6.2, Single Qualification, Latest Edition with API 1104 "Qualification of Welders - Single Qualification"

5. C.(2)(a): Added a "-" in 1-1/4"

5. C.(6)(a): Added a "-" in 1-1/4" and replaced "≤" with "<" than 0.188 wall thickness.

5. C.(7): Replaced "Section 6 of API 1104" with "Qualification of Welders". Replaced "Paragraph 6.2 of API 1104" with "Single Qualification of API 1104".

5. D. Pipeline/Fabrication Multiple - Qualification

5. D.(1): Replaced "Section 6.3 of API 1104" with "Multiple Qualification of API 1104"

5. D.(2)(c): Replaced "API 1104, Section 6.4 and 6.5" with "Visual Examination and Destructive Testing".

5. D.(4): Replaced "Section 6.3 of API 1104" with "Multiple Qualification of API 1104" and "Paragraph 6.3.2 of API 1104" with "Multiple Qualification of API 1104".

5. E. in-Service (Maintenance) Welding Test

5. E.(3): Replaced Paragraph 6.2.2, API 1104, Latest Edition" with "Single Qualification, API 1104".

5. E.(4): Replaced "API 1104. Appendix B, Latest Edition" with "API 1104. Appendix B, In-Service Welding".

5. E.(5): Replaced "Appendix B and Paragraph 6.4 and 6.5" with "API 1104 Appendix B In-Service Welding and Visual Examination and Destructive Testing".

5. E.(7)(a): Replaced with "PHMSA Part 192, (Subpart E, Welding of Steel in Pipelines), (Subpart M - Maintenance), (Appendix C - Qualifications of Welders for Low Stress Level Pipe)".

UNCONTROLLED IF PRINTED

- 5. E.(7)(b): Added "In-Service Welding".
- 6. service Line Welding
- 6. B." Replaced "Appendix C of CFR DOT 192" with "Appendix C - Qualifications of Welders for Low Stress Level Pipe of PHMSA Part 192".
- 7. Workmanship
- 7. A.(2): Replaced "section 9.7, API 1104, latest edition" with "Visual Acceptance Standards for Undercutting in API 1104".
- 7. A.(6): Replaced "API 1104 9.3.7" with " API 1104 Radiographic Testing".
- 9. Destructive Testing
- 9. A.(1): Replaced "DOT 192, Subpart E" with "PHMSA Subpart E, Welding of Steel in Pipelines".
- 9. B. Requalification of Welder
- 9. B.(1): Replaced "welder will be given one more opportunity to". This now reads, "Following on the spot training and procedure review the welder will be given one more opportunity to submit at least two additional sample tests and if both tests are successful there will be no need to perform a full test."
- 9. B.(2): Revised to read. "A welder that fails a requalification test may a qualify, at a later date by participating in additional training and procedure review and producing a full initial test under the supervision of a qualified welding inspector as outlined in this manual for appropriate initial qualification."
- 9. B.(3): Added: "After a period of no less than 5 days, the employee will be re-evaluated, using the same evaluation methods used for the initial qualification. This will ensure that the employee is not being tested on their short-term memory."

Supersedes: April 1, 2013

CHANGE SUMMARY

April 1, 2013

Change Summary April 1, 2013

Docu- ment	Change Summary	Previous Document Dated	Current Docu- ment Dat- ed
FORW	<p style="text-align: center;">Forward:</p> <p style="text-align: center;">Division Director replaces Division Manager</p> <p>Updated Office Phone Numbers for the following individuals:</p> <p style="text-align: center;">Operating & Maintenance Plan: Jim Burke - 618-253-1694</p> <p style="text-align: center;">Standards and Materials: Eddie Lynch - 217-535-5069</p> <p style="text-align: center;">Technical Services: Gerry Turner - 217-535-5023</p>	January 1, 2013	April 1, 2013
ABND 2.01	<p style="text-align: center;">Abandonment of Gas Facilities:</p> <p>Gas Standards Committee made revisions primarily addressing the position a tap should be left in once the abandonment is completed. On all PE mains and steel distribution mains, the cutters/punches are to be left in the down position. On all transmission and high pressure distribution mains, the cutters/punches are to be left in the up position so there is no obstruction inside the pipe.</p> <p style="text-align: center;">1. Mains</p> <p style="text-align: center;">Inserted a new item in the Main, General section:</p> <p>1. A.(5): "If the fitting used to shutoff gas to any main, distribution, high pressure distribution, or transmission, to be abandoned is equipped with a stem which seats closed within the fitting and not an internal cutter/punch assembly, it should be left in the closed position once the abandonment is complete."</p> <p>1. A.(6): Transmission and steel high pressure distribution main need to be free of obstructions so that a pig can be run through the line. Any fitting that has an internal cutter/punch should be left in the up position after abandonment is completed.</p> <p style="text-align: center;">1. B.(3): Inserted new item in PE Mains:</p> <p style="text-align: center;">"Taps should be left in the down position on all PE mains once the abandonment is complete."</p> <p style="text-align: center;">1. C.(1): Inserted new item in Steel Mains:</p> <p style="text-align: center;">"Prior to any cutting on steel pipe an electrical bond should be installed. See ACIG 2.01"</p> <p style="text-align: center;">1. C.(4): Inserted new item for steel distribution mains:</p> <p style="text-align: center;">"Taps with an internal cutter/punch assembly should be left in the down position on distribution mains with MAOP of 60 psig or less once the abandonment is complete."</p> <p style="text-align: center;">1. C.(5): inserted new item for transmission and high pressure main:"Taps with an internal cutter/punch assembly should be left in the up position on transmission and steel high pressure distribution mains, once the abandonment is complete."</p> <p>1. D.(3): Revised language when abandoning a regulator station, any pressurized main remaining shall be treated in same manner as described in the Main section shown above.</p>	January 1, 2013	April 1, 2013

UNCONTROLLED IF PRINTED

	<p style="text-align: center;">2. Services</p> <p style="text-align: center;">2. A. General: New items added:</p> <p>2. A.(7): " Prior to any cutting on steel pipe an electrical bond should be installed. See ACIG 2.01"</p> <p>2. A.(11): "Transmission and steel high pressure distribution main need to be free of obstructions so that a pig can be run through the line. Any service tap that has an internal cutter/punch should be left in the up position after abandonment is completed."</p> <p>2. A.(12): "If the service tap is equipped with a stem which seats closed within the fitting and not an internal cutter/punch assembly, it should be left in the closed position once the abandonment is complete."</p> <p style="padding-left: 40px;">2. A.(13): "If service tap is not accessible, the tap will remain in the open position."</p> <p>2. A.(14): "When service tap is not accessible and a line stopper fitting is installed on the service line, the service stub will be under operating pressure once the" abandonment is complete.</p> <p>2. B.(6): Revised language in PE Service form PE Mains: "Service taps should be left in the down position on all PE mains once the abandonment is complete. In order to leak test the cap connection, run the tee up to allow gas to enter the service stub then return the tee to the down position. " Added "all PE mains"</p> <p>2. C.: Added new items in PE Service Lines with Compression Outlet Tees:</p> <p>2. C.(4): "Service taps with an internal cutter/punch assembly should be left in the down position on steel distribution mains with MAOP of 60 psig or less once the abandonment is complete. In order to leak test the cap connection, run the tee up to allow gas to enter the service stub then return the tee to the down position."</p> <p>2. C.(5): "Service taps with an internal cutter/punch assembly should be left in the up position on transmission and high pressure distribution mains once the abandonment is complete."</p> <p style="text-align: center;">2. D.: Steel Service Lines</p> <p style="text-align: center;">Inserted the following new items</p> <p>2. D.(2): "Service taps with an internal cutter/punch assembly should be left in the down position on steel distribution mains with MAOP of 60 psig or less once the abandonment is complete. In order to leak test the cap connection, run the tee or punch up to allow gas to enter the gas to enter the service stub."</p> <p>2. D.(3): Service taps with an internal cutter/punch assembly should be left in the up position on transmission and high pressure distribution mains once the abandonment is complete.</p> <p>2. D.(5): Included "does not have an accessible service tee" as another situation where a line stopper can be installed on the service line.</p> <p>2. E.(3): When abandoning a farm tap, the pressurized service line remaining shall be treated in the same manner as Service Lines shown above. Deleted the word "Steel" encase there are situations where a farm tap is installed off of HDPE main.</p> <p style="text-align: center;">4. G.: Corrected reference to F. (2) from E. (2).</p>		
<p>BORE 2.05</p>	<p style="text-align: center;">Typical Sewer Installation</p>	<p style="text-align: center;">January 1, 2013</p>	<p style="text-align: center;">April 1, 2013</p>

	Typical 12. Home on Crawl Space - Very Elevated Lot - Corrected the picture and heading.		
CORR 0	Added CORR 3.17 Cased Crossing Monitoring	January 1, 2013	April 1, 2013
CORR 2.03	Coatings 5.: Approved Cold Applied Wax Tapes 5. D.: Deleted the Tapecoat Rugged Wrap since it is not used in the same manner as the Glas-Wrap.	January 1, 2013	April 1, 2013
CORR 2.19	Cathodic Protection Test Points 3. Cased Crossings 3.: Added reference to new Standard CORR 3.17 Cased Crossing Monitoring	April 1, 2012	April 1, 2013
CORR 2.28	Evaluation of Corrosion 5. Allowable Pit Length Tables 5. A. (1): Inserted new, "The tables below are not valid for steel pipe with yield strength specifications less than 35,000 psig. Contact Corrosion Control personnel for allowable pit lengths if pipe is less than 35,000 psig. If the yield strength of the pipe is not known, allowable pit lengths should be based on a pipe with yield strength of 24,000 psig."	April 1, 2012	April 1, 2013
CORR 2.30	Buried Pipe Examination 2. Buried Pipe Examination 2. B.: Clarified by adding "and the existing pipe is planned to remain in service." Buried Pipe Examination is required any time an existing main or service pipe is exposed and that pipe is planned to remain in service. 2. F.: Clarified by adding "or when an existing pipe is planned to be retired and will not remain in service." Buried Pipe Examination is not required for pipe that is being abandoned or is planned to be taken out of service. 3. Distribution 3. A.: Removed "Corrosion and Steel Damage Evaluation" since it is covered in CORR 2.31. 3. A.: Clarified appropriate office by adding "local Operating Center, Damage Prevention Headquarters or Gas Operations and Services Office". 3. B.: In addition, added for transmission or high pressure distribution that are exposed "the office entering the information into PEET should retain a copy for their yearly file and send the original to Pipeline Integrity, Mail Code D-50." 5. Completion Instructions 5. A. 7.: Added to Location Drawing: "Proper dimension should be included which will enable the pipe to be located and mapped." Added a Note: "Data provided by Damage Prevention's Watch and Protect to provide GPS coordinates instead of location drawing."	January 1, 2013	April 1, 2013

	<p style="text-align: center;">7. Records</p> <p>Expanded to more clearly identify what and where records are maintained.</p> <p>7. A.: Added new: "Originals of Buried Pipe Examination Forms for distribution mains and services will be filed year at the appropriate local operating center office, damage prevention office or Gas Operations and Services office."</p> <p>7. B.: Added new: "Copies of Buried Pipe Examination Forms for transmission and high pressure distribution mains and services will be filed by year at the appropriate local operating office , damage prevention office, or Gas Operations and Services office."</p> <p>7. C.: Added new: "Originals of Buried Pipe Examination Form for transmission and high pressure distribution mains and services will be kept by Pipeline Integrity in Decatur."</p>		
<p>CORR 2.31</p>	<p style="text-align: center;">Corrosion and Steel Damage Evaluation</p> <p style="text-align: center;">2. Distribution</p> <p>2. C.: When Corrosion and Steel Damage Evaluation form is completed on transmission and high pressure distribution pipe the information is to be entered into PEET by the appropriate local Operating Center office or Gas Operations and Services office and the original sent to Pipe Integrity, Mail Code D-50.</p> <p style="text-align: center;">6. Records</p> <p>Expanded to more clearly identify what and where records are maintained.</p> <p>6. A.: Added new: "Originals of Corrosion and Steel Damage Evaluations for distribution mains and services will be filed year at the appropriate local operating center office."</p> <p>6. B.: Added new: "Copies of Corrosion and Steel Damage Evaluations for transmission and high pressure distribution mains and services will be filed by year at the appropriate local operating office."</p> <p>6. C.: Added new: "Originals of Corrosion and Steel Damage Evaluations for transmission and high pressure distribution mains and services will be kept by Pipeline Integrity in Decatur."</p>	<p>January 1, 2013</p>	<p>April 1, 2013</p>
<p>CORR 3.15</p>	<p style="text-align: center;">Rectifier Installation</p> <p>2. B.(2): Revised so that Corrosion Control personnel designing the rectifier installation will determine and specify anode spacing and installation methods. Removed the typical anode spacing.</p> <p style="text-align: center;">4.: Rectifier Ground Bed Header Lead Connection</p> <p>4. A.: Added Dryconn VisiLock with Smart Gel Anode Splice Box.</p> <p>4. B.: Added Dryconn VisiLock with Smart Gel Anode Splice Box.</p> <p>4. C.(1): Inserted description of the Dryconn VisiLock with Smart Gel Anode Splice Box.</p> <p>4. C.(2): Identified the previous description as 3M's Scotchcast resin splice kit.</p> <p>4. D.(1): Inserted instructions for installing the Dryconn VisiLock with Smart Gel Anode Splice Box.</p> <p>4. D.(2): Identified previous instruction as those for the 3M's Scotchcast resin splice kit.</p>	<p>April 1, 2012</p>	<p>April 1, 2013</p>

UNCONTROLLED IF PRINTED

CORR 3.17	<p style="text-align: center;">New Standard: Cased Crossing Monitoring</p> <p style="text-align: center;">Provides requirements for monitoring existing cased crossings</p>	N/A	April 1, 2013
EMER 2.02	<p style="text-align: center;">Dispatch Center</p> <p style="text-align: center;">3. Cold Weather Electrical Outage and Restoring Electric Service</p> <p style="text-align: center;">3. D.: Update Gas Technical Services Supervisors' contact information. Steve Hays replaced Mike Tipton covering Division 4. Ed Streicher replaced Ron Kelly covering Divisions 5 & 6. Corrected Kelly Coppernoll's cell phone number.</p>	April 1, 2012	April 1, 2013
EMER 2.04	<p style="text-align: center;">Gas Field Personnel</p> <p style="text-align: center;">9. High Pressure Situation</p> <p style="text-align: center;">9. K.: In the event the system pressure exceeds MEP the Gas Supervisor will immediately contact Managing Supervisor Operations, Gas Compliance. Add "Gas Compliance".</p> <p style="text-align: center;">10. Loss and Restoration of Services</p> <p style="text-align: center;">10. G.: Replaced Division Manager with Division Director.</p>	January 1, 2013	April 1, 2013
EMER 2.05	<p style="text-align: center;">Natural Disasters or Civil Disobedience</p> <p style="text-align: center;">2. Natural Disasters</p> <p style="text-align: center;">2. H.: Replaced Manager Gas Compliance with Managing Supervisor Operations - Gas Compliance</p> <p style="text-align: center;">4. Civil Disobedience</p> <p style="text-align: center;">4. B.(4): Their replaced There</p>	October 1, 2011	April 1, 2013
EMER 2.06	<p style="text-align: center;">Emergency Personnel, Materials, Equipment and Tools</p> <p style="text-align: center;">4. Non Centralized Emergency Gas Material</p> <p style="text-align: center;">4. A.(1): Deleted "All operating areas will have a minimum of 20' of each size of plastic pipe used in that area.</p> <p style="text-align: center;">4. A.(7): Revised language on storing PE pipe. "The shelf life of PE pipe is 2 years from the date of manufacture. Pipe that is stored for emergencies should be rotated to make sure that no plastic pipe goes past the shelf life."</p>	January 1, 2011	April 1, 2013
EMER 2.08	<p style="text-align: center;">Investigation of Failures</p> <p>Throughout this section Gas Compliance was the group responsible for investigating failed materials. This function is now being performed by Gas Standards & Procedures group. Wherever Gas Compliance was stated in this section, it was replaced by Gas Standards & Procedures.</p> <p style="text-align: center;">Failed materials are to be shipped to: Gas Standards & Procedures, 10th Floor, 607 East Adams, Springfield, IL 62701 and not the Gas Training Center.</p> <p style="text-align: center;">Failed Gas Material Tags, Stock Code 16 01 631, are being updated with the correct Ship To address.</p>	July 1, 2012	April 1, 2013
EMER 2.10	<p style="text-align: center;">CNG Trailer</p>	January 1, 2013	April 1, 2013

UNCONTROLLED IF PRINTED

	2.: Updated contact information, Ed Streicher replaced Ron Kelly. Also corrected Kewanee is in Division 1.		
INVE 2.02	<p>Investigation of Fires</p> <p>6. Communication with the Media</p> <p>6.B; & 6. E.: Replaced Manager Gas Compliance with Managing Supervisor Operations - Gas Compliance</p> <p>7. Engagement of Outside Entities to Assist with the Investigation</p> <p>7. C.: Replaced Manager Gas Compliance with Managing Supervisor Operations - Gas Compliance</p>	January 1, 2013	April 1, 2013
INVE 4	Missed showing Form 02 - Chain of Custody Log in the January 1, 2013 O&M update. It was on INVE 0 Table of Contents	January 1, 2013	April 1, 2013
LEAK 0	<p>LEAK 4:</p> <p>Update Form 01 - Gas Leak Case Field Report (Printed 01/15/2013)</p> <p>Added Reference 14. Bascom Turner Gas Rover Operation Manual</p>	January 1, 2013	April 1, 2013
LEAK 2.03	<p>Leak Investigation Form:</p> <p>2. A.(7): GCS No.: Revised to include Gas Supervisor approving Gas Leak Case Field Report but removed Gas Supervisor as the one entering the GLCFR into GCS.</p>	October 1, 2011	April 1, 2013
LEAK 2.04	10. Ameren Illinois Leak Classification Guidelines: Replaced Card with the one that was actually printed in January, 2013. Had initially failed to put the greater than sign ">" in front of 0% LEL	January 1, 2013	April 1, 2013
LEAK 2.05	<p>Gas Leak Case Field Report</p> <p>The Gas Leak Case Field Report Form has been revised and has a Printed date of 01/15/2013</p> <p>2. Leak Case Field Report Sections</p> <p>2. A. Leak Case Information</p> <p>2. A.(2): Deleted "Location "</p> <p>2. A.(7): Added: GPS coordinates - GCS requires in decimal degree format</p> <p>2. A.(12): Added: Job Order # - used to document an associated DOJM order</p> <p>2. B. Surveillance Data</p> <p>2. B.(2): Revised "Volume" by eliminating the Note that were added in the January 1, 2013 O&M update to address >0 LEL to 4% Gas within 5 feet of Foundation Wall since this was not on the current GLCFR form. Form has now been update to include >0 LEL to 4% Gas.</p> <p>2. B.(4): In the Verification Method, added "Below ground leaks must be verified/classified by CGI unless volume is blowing." In the above ground leaks, replaced "Soap" with "Leak Detection Fluid".</p> <p>2. C. Repair Data</p>	January 1, 2013	April 1, 2013

UNCONTROLLED IF PRINTED

2. C.(3): In Pressure Test Data, revised to "required if pipe is replaced or service is disconnected from gas supply and reinstalled after repair is made."

2. C.(3)(d): Revision to title: Pipe Replaced/Srv Reinstated, Reinstated replaced Disconnected. Change was made to clarify that test pressure data is only required when the main or service is temporarily disconnected and then reconnected (reinstated). Permanently disconnect pipe does not require a pressure test.

2. C.(5) Revised title to Leak Checked Back to Main from FI Back to Main

2. C.(6): Deleted P/S Reading since P/S reading is entered on Buried Pipe Examination form.

2. C.(7)(g): Revised title to Incorrect Operations from Operations in order to be consistent with the DOT Annual Report categories.

2. C.(7)(h): Revised title to Not Observed from Other in order to be consistent with the DOT Annual Report categories.

2. C.(11): In Remarks, deleted "Note if soap, leak detection fluid, was used to check repairs for leak."

2. D. Leak Recheck

Specified "below ground" leaks that could have residual gas present versus "below grade"

2. D.(4): Added new: CGI Serial - (required) the serial number of the calibrated CGI used to recheck the leak.

2. D.(5): Revised the Verification Method for below ground rechecks. "The recheck of a repaired leak shall be performed with a gas detection instrument (FI unit or CGI and bar holes) to verify no gas exists below grade."

Gas Leak Case Field Report Form:

Section A:

Removed "Location"

Moved "Located on Federal Land" to below "Leak Location"

Added "JOB ORDER #"

Section B: Surveillance

VOLUME: Added >0%LEL to 4% GAS

VERIFICATION METHOD: LEAK DETECTION FLUID replaced SOAP

Section C: Repair

Retitled LEAK CHECKED BACK TO MAIN replaced FI Back to Main

Retitled PIPE REPLACED/SRV REINSTALLED from Pipe Replaced/SRV Disconnected

Removed P/S Reading

Removed the External and Internal Corrosion Exam for Service and Main sections

LEAK CAUSE:

INCORRECT OPERATIONS replaced Operations

NOT OBSERVED replaced Other

REPAIR TYPE:

UNCONTROLLED IF PRINTED

	<p>Added: WELD and RETIRE to selections Section D Leak Recheck: Added CGI SERIAL: VERIFICATION METHOD: Deleted "Soap" 4. Mechanical Fitting Leak 4. D.: Leak Case Field Report Section was revised as described in Section C: Repair shown above. 4. F.: Mechanical Fitting Leak Data Form Deleted the note at the bottom of form to Send to Gas Compliance Specialist: Patty Marcolini</p>		
LEAK 4	<p>Updated Form 01 - Gas Leak Case Field Report (Printed 01/15/2013) Added Reference 14. Bascom Turner Gas Rover Operation Manual</p>	April 1, 2012	April 1, 2013
LOCT 0	<p>LOCT 4: Added: Reference 22 - Radiodetection RD8000 User Guide Reference 23 - MADE Acoustic Gas Tracker Operation Manual Reference 24 - MADE Gas Tracker New Quick Start Guide Reference 25 - Jameson Gas Line Tracer Instruction Manual</p>	January 1, 2013	April 1, 2013
LOCT 4	<p>Added: Reference 22 - Radiodetection RD8000 User Guide Reference 23 - MADE Acoustic Gas Tracker Operation Manual Reference 24 - MADE Gas Tracker New Quick Start Guide Reference 25 - Jameson Gas Line Tracer Instruction Manual</p>	January 1, 2013	April 1, 2013
MAIN 1	<p>3. B.: Corrected Stock Code for Safety Barrier Tape - 16 06 958.</p>	January 1, 2013	April 1, 2013
MAIN 2.01	<p>Joint Trench Installation 2. A.(4): Revised to require a note "Joint Trench" be entered on "as built" plans when main is installed in joint trench. Already requires a note on service record. 2. A.(7): New item added that addresses installation of a Safety Barrier Tape when minimum cover cannot be maintained. Consistent with requirement when main is installed in a single trench. 2. A. Figure A revised to reflect minimum cover of 30 inches for gas main.</p>	April 1, 2010	April 1, 2013
MAIN 3.01	<p>Lateral Tap, PE High Volume Tee Deleted the Friatec and Innogaz Tables since Company is going with a single electrofusion manufacturer.</p>	January 1, 2011	April 1, 2013

UNCONTROLLED IF PRINTED

	<p>Retitled the two remaining tables: PE2406/PE2708 - Medium Density PE Pipe - (Yellow) PE3408/PE4710 - High Density PE Pipe - (Black)</p> <p>Grammatical revisions for consistency in the designation of the medium density PE: PE2406/PE2708 and high density PE: PE3408/PE4710</p>		
MAIN 3.02	<p>Lateral Tap, PE, Inline Tee</p> <p>Deleted the Friatec and Innogaz Tables since Company is going with a single electrofusion manufacturer.</p> <p>Retitled the two remaining tables: PE2406/PE2708 - Medium Density PE Pipe - (Yellow) PE3408/PE4710 - High Density PE Pipe - (Black)</p> <p>Grammatical revisions for consistency in the designation of the medium density PE: PE2406/PE2708 and high density PE: PE3408/PE4710</p>	January 1, 2011	April 1, 2013
MAIN 3.03	<p>Lateral Tap, PE, TDW Sidetap</p> <p>Deleted the Friatec and Innogaz Tables since Company is going with a single electrofusion manufacturer.</p> <p>Retitled the two remaining tables: PE2406/PE2708 - Medium Density PE Pipe - (Yellow) PE3408/PE4710 - High Density PE Pipe - (Black)</p> <p>Grammatical revisions for consistency in the designation of the medium density PE: PE2406/PE2708 and high density PE: PE3408/PE4710</p>	January 1, 2011	April 1, 2013
MAIN 3.05	<p>Corrected "Effective Date" which should have been January 1, 2011 not 2010.</p>	April 1, 2010	January 1, 2011
MAIN 3.12	<p>End of Main Extension, PE</p> <p>Deleted the Friatec and Innogaz Tables since Company is going with a single electrofusion manufacturer.</p> <p>Retitled the two remaining tables: PE2406/PE2708 - Medium Density PE Pipe - (Yellow) PE3408/PE4710 - High Density PE Pipe - (Black)</p> <p>Corrections in Stock Codes in the following Tables: PE2406/PE2708 - Medium Density PE Pipe - (Yellow):</p> <ol style="list-style-type: none"> 1. Corrected stock code for Coupling, Electrofusion, PE3408/PE4710 8" to the stock code for Central Plastic coupling. <p>PE3408/PE4710 - High Density PE Pipe - (Black):</p> <ol style="list-style-type: none"> 1. Corrected stock codes for the three Couplings, Electrofusion, PE3408/PE4710 to the Central Plastic stock codes. <p>Grammatical revisions for consistency in the designation of the medium density PE: PE2406/PE2708 and high density PE: PE3408/PE4710</p>	January 1, 2011	April 1, 2013

<p>MAIN 3.13</p>	<p>End of Main Extension, PE, Increasing Size</p> <p>Deleted the Friatec and Innogaz Tables since Company is going with a single electrofusion manufacturer.</p> <p>Retitled the two remaining tables:</p> <p>PE2406/PE2708 - Medium Density PE Pipe - (Yellow)</p> <p>PE3408/PE4710 - High Density PE Pipe - (Black)</p> <p>Grammatical revisions for consistency in the designation of the medium density PE: PE2406/PE2708 and high density PE: PE3408/PE4710</p>	<p>January 1, 2011</p>	<p>April 1, 2013</p>
<p>MAIN 3.14</p>	<p>End of Main Extension, PE, Decreasing Size</p> <p>Deleted the Friatec and Innogaz Tables since Company is going with a single electrofusion manufacturer.</p> <p>Retitled the two remaining tables:</p> <p>PE2406/PE2708 - Medium Density PE Pipe - (Yellow)</p> <p>PE3408/PE4710 - High Density PE Pipe - (Black)</p> <p>Grammatical revisions for consistency in the designation of the medium density PE: PE2406/PE2708 and high density PE: PE3408/PE4710</p>	<p>January 1, 2011</p>	<p>April 1, 2013</p>
<p>METR 0</p>	<p>In METR 2.12 Rotary Meter Differential Testing corrected Item 4 to "Equipment" from "Test Equipment" to match METR 2.12 document.</p> <p>Added new Standards:</p> <p>METR 3.14 425 Meter, Bypass, 2, 5, & 10 PSIG Delivery, 5 - 60 PSIG Inlet</p> <p>METR 3.17 630 Meter, Bypass, 2, 5, & 10 PSIG Delivery 1-60 PSIG Inlet</p> <p>Revised Standards:</p> <p>METR 3.23 15C/3M Meter, 5 & 10 PSIG Delivery Pressure</p> <p>METR 3.26 5M/7M Meter, 5 & 10 PSIG Delivery Pressure</p>	<p>January 1, 2013</p>	<p>April 1, 2013</p>
<p>METR 2.12</p>	<p>Rotary Meter Differential Testing</p> <p>Supervising Engineer Gas IL Metering and Superintendent Gas Technical Services have made significant revisions to this document. These revisions apply primarily to the Gas Technical Services - Metering Technicians.</p> <p>1.: General has been expanded:</p> <p>1. A.: Combined the previous A. and B. into a single sentence: "The industry standard for testing rotary gas meters at a service location is to measure the pressure drop across the inlet and outlet of a rotary meter. This process is known as differential pressure testing."</p> <p>1. B.: Added a general explanation on why differential tests are performed on rotary meters. "Any significant increase in a rotary meter's internal resistance to flow at a known volume and pressure will increase the pressure drop across the meter. Therefore, the rotary meter differential test is a prime indicator of meter condition. Examples of items that will cause an increase in the internal resistance of a rotary meter: binding of the impellers, dirt or debris, worn bearings, too heavy oil, and incorrect oil level."</p>	<p>January 1, 2013</p>	<p>April 1, 2013</p>

UNCONTROLLED IF PRINTED

1. C.: Move text from Periodic Testing section into the General section. "Manufacturer test results have shown that an increase of up to 50% in differential pressure can be tolerated without affecting the rotary meter accuracy by more than 1%, at flow rates of 10% to 100% of meter capacity."

1. D.: Move text for Periodic Testing section into the General section. "Rotary meter accuracy cannot be directly determined by a differential test."

2.: Initial Installation Differential Test

2. A.: Added the words "related to": "A differential test shall be made on each new rotary gas meter installation to establish an acceptable differential related to individual piping configurations and operating pressures."

3. Periodic Test:

3. B.: Clarified a Periodic Test on a rotary meter is required to be conducted on or before the five (5) year anniversary from the meter's last test date.

4.: Equipment

4. F.: Added "Laptop with the current version of Dresser's Differential Test Acceptance Calculator installed or the manufacturer's factory differential pressure curves."

5. Differential Test

Revised to provide more details on activities required to perform a differential test.

5. Differential Test

The following activities are required to provide accurate differential test results:

1. Install a test gauge to measure the pressure at the meter.
2. Install the differential pressure test equipment into the meter inlet and outlet differential taps. Follow the manufacturer's instructions for proper installation and operating procedures.
3. Verify or establish a stable flow through the meter. The minimum flow rate for a proper test must be 10% of the meter capacity.
4. Time/clock the meter or interrogate the electronic index on the meter to determine the minimum test flow requirement is met.
5. Record the differential pressure reading, metering pressure, the test flow rate. The flow rate is either calculated or from an electronic index.
6. Repeat the test to verify an accurate average reading.
7. Compare the data to existing manufacturer's factory differential pressure baseline curves or use Dresser's Differential Test Acceptance Calculator (dP Calculator) to determine the condition of the meter (PASS or FAIL).
8. Remove all test equipment and confirm the meter is returned to normal operating conditions.

6.: Test Record:

6. G.: Added "Dresser's Differential Test Acceptance Calculator (dP Calculator)" as another item that the results can be compared with along with acceptable curve.

	<p>6. H.: Added "Any maintenance activities performed on the meter (e.g. meter oil change, flushing meter, etc)" that should be documented on the test record.</p> <p>6. I.: Added "Pressure sensing line to the corrector is in the open or "On" position.</p> <p>7. Follow-up Action</p> <p>7. A.: Added "dP Calculator" as another item the results of the differential test can be checked against.</p> <p>7. B.: Added "The meter may require corrective maintenance in the field to reduce the differential pressure to an acceptable level or possibly exchange the meter if the differential pressure cannot be reduced." When differential is more than 50% greater than the normal or manufacturer's curve differential.</p> <p>7. C.: Revised to identify "Corrective maintenance activities could include 1) Changing the oil or 2) Cleaning the meter impeller chamber, which could include flushing with an approved solvent."</p> <p>7. D.: Added "Removed meters must be promptly sent to the gas meter shop for testing and corrective action."</p> <p>7. E.: Added "The corrective maintenance activity or meter exchange should be scheduled if it cannot be accomplished during the initial site visit."</p>		
<p>METR 2.20</p>	<p style="text-align: center;">Meter Header Inspection</p> <p>2.: Inspection/Maintenance When A Meter Set is Not Disassembled</p> <p>2. A.(9): Corrected reference to images of banded regulators which should have been "Item 5" not "4".</p> <p>2. A. (10): Corrected reference to images of substandard regulators which should have been "Item 6" not "5". Corrected typo "or" should have been "of".</p> <p>3.: Inspection/Maintenance When A Meter Is Installed/Changed or Set is Disassembled</p> <p>3. A.(8): Corrected reference to images of banded regulators which should have been "Item 5" not "4".</p> <p>3. A.(12): Corrected reference to images of substandard regulators which should have been "Item 6" not "5". Corrected typo "or" should have been "of".</p>	<p>July 1, 2012</p>	<p>April 1, 2013</p>
<p>METR 2.22</p>	<p style="text-align: center;">Pressure Gauges</p> <p>2. A.: Clarified Process Gauge - A pressure gauge utilized for continuously monitoring gas pressure on system or used to perform a leak and/or strength test to establish system MAOP. A process gauge is typically installed at a location such as a regulator station or meter set.</p> <p>Specified if a process gauge is used to verify the facilities' MAOP, the process gauge should have a minimum accuracy of $\pm 0.5\%$ of full scale as designated by the manufacturer and their accuracy verified annually. Reference to PTST 1 that addresses the annual verification.</p> <p>2. B.: Clarified Test Gauge - A pressure gauge, with accuracy, of $\pm 0.5\%$ of full scale, that is periodically verified for accuracy and utilized for activities that require reading accuracy.</p> <p>Deleted "These activities include setting the operating pressure of a regulator and relief valve at a regulator station or a meter set and for</p>	<p>January 1, 2011</p>	<p>April 1, 2013</p>

	<p>verifying customer metering pressures." Activities are listed in 3. Uses of Test Gauges</p> <p>3. H.: Added "Verifying accuracy of process gauges used to record leak and/or strength test that verifies MAOP." under Uses of Test Gauges.</p> <p>Added: Test gauges are entered and maintained in GCS. Test gauges are shown in Specialized Tools and Equipment in Gas Operations and Services website on Scholar.</p>		
METR 3.04	<p>Regulator Sizing - 2 PSIG Delivery Pressure</p> <p>Added the 1" x 1" Actaris CL-31N, 1/4" Orifice regulator, Stock Code 62 06 487</p>	January 1, 2013	April 1, 2013
METR 3.05	<p>Regulator Sizing - 5 PSIG Delivery Pressure</p> <p>Added the 1" x 1" Actaris CL-31N, 1/4" Orifice regulator, Stock Code 62 06 487</p>	January 1, 2013	April 1, 2013
METR 3.06	<p>Regulator Sizing - 10 PSIG Delivery Pressure</p> <p>Added the 1" x 1" Actaris CL-31N, 1/4" Orifice regulator, Stock Code 62 06 487</p>	January 1, 2013	April 1, 2013
METR 3.14	<p>NEW: 425 Meter, Bypass, 2, 5, & 10 PSIG Delivery, 5-60 Inlet</p>	N/A	April 1, 2013
METR 3.15	<p>Formerly METR 3.14 630 Meter, 7" WC Delivery, 1- 60 PSIG Inlet</p>	January 1, 2013	April 1, 2013
METR 3.16	<p>Formerly METR 3.15 630 Meter, Bypass, 7" WC Delivery, 1- 60 PSIG Inlet</p>	January 1, 2013	April 1, 2013
METR 3.17	<p>NEW: 630 Meter, Bypass, 2, 5, & 10 PSIG Delivery, 5-60 Inlet</p>	N/A	April 1, 2013
METR 3.18	<p>Formerly METR 3.16 Multiple Meter Installation</p>	January 1, 2013	April 1, 2013
METR 3.19	<p>Formerly METR 3.17 15C Compact Meter, 7" W.C. Delivery Pressure</p>	January 1, 2013	April 1, 2013
METR 3.20	<p>Formerly METR 3.18 15C Compact Meter, 2 PSIG Delivery Pressure, deleted reference to an electronic corrector required at elevated metering pressure where pressure factor billing is not permitted</p>	January 1, 2013	April 1, 2013
METR 3.21	<p>Formerly METR 3.19 15C/3M Meter, 7" W.C. Delivery Pressure</p> <p>In the drawing, delete item designation for the lateral support bracket at the top of the meter loop.</p> <p>In the installation instructions, added "8. Uni-strut bracing or equivalent should be installed on the top of the meter loop (as shown) when conditions warrant additional lateral support for the meter set."</p> <p>In the Material List table, the lateral support "uni-strut bracing of equivalent" is listed as a non-stock item.</p>	January 1, 2013	April 1, 2013

UNCONTROLLED IF PRINTED

<p>METR 3.22</p>	<p>Formerly METR 3.20 15C/3M Meter, 2 PSIG Delivery Pressure</p> <p>In the drawing, delete item designation for the lateral support bracket at the top of the meter loop.</p> <p>In the installation instructions:</p> <p>Deleted reference to an electronic corrector required at elevated metering pressure where pressure factor billing is not permitted.</p> <p>Added "9. Uni-strut bracing or equivalent should be installed on the top of the meter loop (as shown) when conditions warrant additional lateral support for the meter set."</p> <p>In the Material List table, the lateral support "uni-strut bracing of equivalent" is listed as a non-stock item.</p>	<p>January 1, 2013</p>	<p>April 1, 2013</p>
<p>METR 3.23</p>	<p>Revision to formerly METR 3.21 15C/3M, 5 & 10 PSIG Delivery Pressure - Added 10 PSIG to the Standard.</p> <p>In the drawing, delete item designation for the lateral support bracket at the top of the meter loop.</p> <p>In the installation instructions:</p> <p>Added reference METR 3.06 for regulator sizing for 10 psig delivery. Added the MEP for both the 5 and 10 psig delivery pressure.</p> <p>Deleted reference to an electronic corrector required at elevated metering pressure where pressure factor billing is not permitted.</p> <p>Added "8. The relief valve stack should be locked in the Open position."</p> <p>Added "11. Uni-strut bracing or equivalent should be installed on the top of the meter loop (as shown) when conditions warrant additional lateral support for the meter set."</p> <p>In the Material List table, the lateral support "uni-strut bracing of equivalent" is listed as a non-stock item.</p>	<p>January 1, 2013</p>	<p>April 1, 2013</p>
<p>METR 3.24</p>	<p>Formerly METR 3.22 5M/7M, 7" W.C. Delivery Pressure</p> <p>In the drawing, delete item designation for the lateral support bracket at the top of the meter loop.</p> <p>In the installation instructions, added "9. Uni-strut bracing or equivalent should be installed on the top of the meter loop (as shown) when conditions warrant additional lateral support for the meter set."</p> <p>In the Material List table, the lateral support "uni-strut bracing of equivalent" is listed as a non-stock item.</p>	<p>January 1, 2013</p>	<p>April 1, 2013</p>
<p>METR 3.25</p>	<p>Formerly METR 3.23 5M/7M Meter 2 PSIG Delivery Pressure</p> <p>In the drawing, delete item designation for the lateral support bracket at the top of the meter loop.</p> <p>In the installation instructions:</p> <p>Deleted reference to an electronic corrector required at elevated metering pressure where pressure factor billing is not permitted.</p> <p>Added "10. Uni-strut bracing or equivalent should be installed on the top of the meter loop (as shown) when conditions warrant additional lateral support for the meter set."</p>	<p>January 1, 2013</p>	<p>April 1, 2013</p>

	In the Material List table, the lateral support "uni-strut bracing of equivalent" is listed as a non-stock item.		
METR 3.26	<p>Revision to formerly METR 3.24 5M/7M Meter 5 & 10 PSIG Delivery Pressure. Added 10 PSIG to the Standard</p> <p>In the drawing, delete item designation for the lateral support bracket at the top of the meter loop.</p> <p>In the installation instructions:</p> <p>Added reference METR 3.06 for regulator sizing for 10 psig delivery. Added the MEP for both the 5 and 10 psig delivery pressure.</p> <p>Deleted reference to an electronic corrector required at elevated metering pressure where pressure factor billing is not permitted.</p> <p>Added "8. The relief valve stack should be locked in the Open position."</p> <p>Added "11. Uni-strut bracing or equivalent should be installed on the top of the meter loop (as shown) when conditions warrant additional lateral support for the meter set."</p> <p>In the Material List table, the lateral support "uni-strut bracing of equivalent" is listed as a non-stock item.</p>	January 1, 2013	April 1, 2013
PMRK 3.02	<p>Carsonite Pipeline Markers:</p> <p>Deleting the Single Sided Markers. All markers will be Double Sided and will be 62 and 78 inches long.</p>	April 1, 2012	April 1, 2013
POLY 0	<p>POLY 2.05 3. Electrofusion Couplings and Elbows</p> <p>POLY 3.02 6. Elbows - 90°</p>	January 1, 2013	April 1, 2013
POLY 1	<p>2. D.: Shelf life of PE pipe is 2 years even if it is stored inside or protected from ultraviolet radiation. "The shelf life of PE2406/PE2708 or PE3408/PE4710 shall not exceed 2 years from the manufactured dated stamped on the pipe".</p> <p>8. B.(3): Revised the mechanical weak link language to indicate the Condux break-away swivel is one of the commercially available weak links. The Condux swivel is now included in the Specialized Tools and Equipment site under Gas Operations and Services website on Scholar.</p>	January 1, 2013	April 1, 2013
POLY 2.01	<p>2. B.: Corrected the SDR rating for the 1" CTS PE3408/4710 pipe to 11.4 from 11.5</p>	July 1, 2012	April 1, 2013
POLY 2.05	<p>Electrofusion</p> <p>3. Electrofusion Couplings and Elbows: Added Elbows since they have basically the same electrofusion procedures as couplings.</p> <p>3. A.(6)(a): Added elbow in the preparation instruction. Added instructions on how to mark the area to be scrapped for installation of an elbow. "The elbow has a "knit" line, raised thin line on the outer diameter and indicates insertion depth of the pipe. The knit line should be placed adjacent to the end of the pipe and used as a guide in marking the pipe." Added a picture of an elbow showing the knit line. Added a picture of elbow.</p>	August 1, 2011	April 1, 2013

	<p>3. A. (8): Added "elbow" in the procedures for wiping the scrap area with 96% alcohol solution.</p> <p>3. A. (9): Added "elbow" in the procedures in case the coupling or elbow becomes contaminated prior to installation.</p> <p>3. B.(1)(a): Added "elbow" in the joint assembly instructions for remarking insertion depth. Added instructions on how to mark the area to be scrapped for installation of an elbow. "The elbow has a "knit" line, raised thin line on the outer diameter and indicates insertion depth of the pipe. The knit line should be placed adjacent to the end of the pipe and used as a guide in marking the pipe."</p> <p>3. B.(2), (3), (4), & (5): Added "elbow" in the installation on the pipe instructions.</p> <p>3. B.(5): Added clarification that the maximum gap shown in table is for the coupling.</p> <p style="padding-left: 40px;">3. B.(6): Added a picture of a clamped elbow</p> <p>3. C.: Added "elbow" in the fusion instructions.</p>		
<p>POLY 3.02</p>	<p style="text-align: center;">Electrofusion Fittings:</p> <p>1.: Tapping Tee Kits: Deleted the Friatec and Innogaz stock code columns and renamed the Central Plastics column to "Stock Code". Added Stock Code for the 8 IPS x 1/2"CTS and 8 IPS x 1"CTS tapping tees.</p> <p>2.: High Volume Tapping Tees: Deleted the Friatec and Innogaz stock code columns and renamed the Central Plastics column to "Stock Code". Added 2" thru 6" x 1-1/4" tapping tees. Corrected stock code for the 8"x 2".</p> <p>3.: Couplings: Deleted the Friatec and Innogaz stock code columns and renamed the Central Plastics column to "Stock Code"</p> <p>4.: Reducer Couplings: Deleted the Friatec and Innogaz stock code columns and renamed the Central Plastics column to "Stock Code". Corrected stock codes for the 1-1/4" x 1" CTS and 2" x 1-1/4"IPS.</p> <p>5.: End Caps: Deleted the Friatec and Innogaz stock code columns and renamed the Central Plastics column to "Stock Code". Added 3" thru 8" electrofusion caps.</p> <p style="padding-left: 40px;">6.: Added Elbow - 90°: 2"</p>	<p>April 1, 2012</p>	<p>April 1, 2013</p>
<p>PTST 0</p>	<p style="text-align: center;">Added PTST 4 Forms and Reference Materials Form 1 - Gas Leak and Strength Test Stamps</p>	<p>January 1, 2013</p>	<p>April 1, 2013</p>
<p>PTST 1</p>	<p>1. F.: Added an exception for not pressure testing against a closed valve. "This does not apply to testing against a closed service meter valve as long as test pressure does not exceed 1.1 times pressure rating of valve."</p> <p style="text-align: center;">3. Test Recording Methods</p> <p>3. A.: Revised by deleting the "Calibrated Test" from gauges that are used to record tests that verify MAOP. Clarified that gauges used to verify facilities' MAOP should have a minimum accuracy of ±0.5% full scale, with test duration less than 8 hours. Added that test gauges and calibrating test gauges also have this minimum accuracy.</p> <p>3. B.: Added "Process gauges used to perform a leak and/or strength test should be verified for accuracy (± 0.5%) at mid-scale annually during the first (1st) quarter of the year. New process gauges placed into</p>	<p>January 1, 2013</p>	<p>April 1, 2013</p>

	<p>service do not need to be verified for accuracy until the next first (1st) quarter. A test gauge or calibrating test gauge should be used to verify accuracy of a process gauge.</p> <p>3. C.: Changed "should" to "shall" which requires pressure recording charts on any leak and/or strength test, which verifies the facilities' MAOP, with test duration of 8 hours or longer.</p> <p>3. Table: Added a table listing stock codes for those process gauges that have a minimum of $\pm 0.5\%$ full scale as specified by the manufacturer. Currently, there are two models of Ashcroft gauges stock coded that are essentially the same with the exception of the case material. The Aluminum case model will no longer be purchased but can continue to be used.</p> <p>9. Test Record</p> <p>9. A. (1): Added a copy of the Gas Leak Test Stamp and Gas Strength Test Stamp that is currently placed on plans designed at the Distribution Design Centers and Gas Operations and Services - Engineering.</p> <p>9. A. (2): Added copies of the stamps are in PTST 4 and a copy can be attached to construction or maintenance plans that are pre-stamped.</p>		
PTST 2.01	<p>Leak Test</p> <p>5. Leak Test Records</p> <p>5. C.: Revised to "Gauges can be used for test duration less than 8 hours. See PTST 1". Deleted "record test gauge ID or serial number on the test record".</p>	January 1, 2013	April 1, 2013
PTST 2.02	<p>Strength Test</p> <p>4. Strength Test Records</p> <p>4. C.: Revised to "Gauges can be used for test duration less than 8 hours. See PTST 1". Deleted "record test gauge ID or serial number on the test record".</p>	January 1, 2013	April 1, 2013
PTST 4	<p>NEW: Added:</p> <p>Form 1 - Gas Leak and Strength Test Stamps</p>	N/A	April 1, 2013
REGS 0	<p>Missed deleting the DWG files listed in REGS 4. These files were deleted in REGS 4 in the January 1, 2013 O&M update.</p>	January 1, 2011	April 1, 2013
SECR 2.02	<p>Critical Gas Facility Security Measures</p> <p>Through-out SECR 2.02 the term Manager of the targeted area(s) is used. Ameren has replaced the Manager title with Director. Therefore, the term Division Director of the targeted area(s).</p> <p>2: T. & U. sequencing was corrected. January 1 version had these as 2. L & M. located after 2. S.</p> <p>4. C.(4): Deleted a duplicate statement</p> <p>4. E.: Deleted a duplicate sentence</p> <p>4. J.: Corrected "along" to "alone"; "Minimize the time that an employee is required to work alone at a Critical Gas Facility"</p>	January 1, 2013	April 1, 2013

SERV 0	Deleted SERV 3.08 Farm Tap, Double Cut, 741 - 1000 psig inlet pressure.	October 1, 2011	April 1, 2013
SERV 1	2. A.: Corrected Stock Code for Safety Barrier Tape - 16 06 958. 3. C.: Revised to indicate service lines 2 inch and larger should be backfilled in same manner as a gas main.	January 1, 2013	April 1, 2013
SERV 2.02	Excess Flow Valves 3. EFV Sizing 3. E.: 3/4" Steel EFV's: Maximum Flow values have been reduced by 20%. The initial values shown in the table were determined to be trip flow rates. Manufacturer recommended setting maximum flow values 20% below the trip flow rate. The sizing table was expanded to inlet pressures up to 1000 psig since the double-cut farm tap design goes up to 1000 psig.	January 1, 2013	April 1, 2013
SERV 2.03	Farm Tap Installations 2. B. (2): There is only one standard for a double cut farm tap. Former SERV 3.08 drawing and material list was moved to SERV 3.07. 2. D.: Inserted a new item. "For a double step farm tap, the standard outlet set point of the first cut regulator is 100 psig. The 1805 relief will be set at 120 psig." 2. E.: Changed double-step to double-cut. 4. Testing 4. B.: Changed double-step to double-cut. 5. Inlet Valves 5. A.: Changed double-step to double-cut. 5. B.: Inserted model number of the weld Mueller Valve , H-17900, that can be installed in the service line to a farm tap. 5. D.: Inserted model numbers of Mueller Valves, H-17656 valve tee or H-17800 curb valve tee, that should be used in lieu of a punch tee if the wall thickness of the main is greater than 0.281 inches. Added a reference to TAP 2.05 which provide maximum wall thickness for a punch tee. 7. Farm Tap Capacity Tables 7. B.: Changed 2nd step to 2nd cut and double-step to double-cut 7. C.: Changed 1st step to 1st cut.	January 1, 2013	April 1, 2013
SERV 2.06	Gas Service Transaction Card Revision to Form/Card; Replaced HSR with 1813C regulator 5. Completion Instructions 5. B.(b)(26): Revised language to "Updates to the Service Transaction card may change the service regulator. If service regulator is listed, check the box. If the model is not listed on the card, the box next to the blank line should be checked and the manufacturer model number written in on the blank line.	October 1, 2011	April 1, 2013

UNCONTROLLED IF PRINTED

<p>SERV 3.01</p>	<p>1/2" PE Service Line, Flex Riser: Deleted the Friatec and Innogaz Tables since Company is going with a single electrofusion manufacturer. Retitled the two remaining tables: PE2406/PE2708 - Medium Density PE Pipe - (Yellow) 1. Added a 8"IPS x 1/2"CTS service - G311308 PE3408/PE4710 - High Density PE Pipe - (Black) Grammatical revisions for consistency in the designation of the medium density PE: PE2406/PE2708 and high density PE: PE3408/PE4710</p>	<p>July 1, 2012</p>	<p>April 1, 2013</p>
<p>SERV 3.02</p>	<p>1/2" PE Service Line, Rigid Riser: Deleted the Friatec and Innogaz Tables since Company is going with a single electrofusion manufacturer. Retitled the two remaining tables: PE2406/PE2708 - Medium Density PE Pipe - (Yellow) 1. Added a 8"IPS x 1/2"CTS service - G312308 PE3408/PE4710 - High Density PE Pipe - (Black) Grammatical revisions for consistency in the designation of the medium density PE: PE2406/PE2708 and high density PE: PE3408/PE4710</p>	<p>July 1, 2012</p>	<p>April 1, 2013</p>
<p>SERV 3.03</p>	<p>1" PE Service Line, Flex Riser: Deleted the Friatec and Innogaz Tables since Company is going with a single electrofusion manufacturer. Retitled the two remaining tables: PE2406/PE2708 - Medium Density PE Pipe - (Yellow) 1. Added a 8"IPS x 1"CTS service - G321308 2. Changed EFV to the Series 1100 PE3408/PE4710 - High Density PE Pipe - (Black) 1. Changed EFV to the Series 1100 Grammatical revisions for consistency in the designation of the medium density PE: PE2406/PE2708 and high density PE: PE3408/PE4710</p>	<p>July 1, 2012</p>	<p>April 1, 2013</p>
<p>SERV 3.04</p>	<p>1" PE Service Line, Rigid Riser: Deleted the Friatec and Innogaz Tables since Company is going with a single electrofusion manufacturer. Retitled the two remaining tables: PE2406/PE2708 - Medium Density PE Pipe - (Yellow) 1. Added a 8"IPS x 1"CTS service - G322308 2. Changed EFV to the Series 1100 PE3408/PE4710 - High Density PE Pipe - (Black) 1. Changed EFV to the Series 1100</p>		<p>April 1, 2013</p>

UNCONTROLLED IF PRINTED

	Grammatical revisions for consistency in the designation of the medium density PE: PE2406/PE2708 and high density PE: PE3408/PE4710		
SERV 3.05	<p>2" PE Service Line:</p> <p>Deleted the Friatec and Innogaz Tables since Company is going with a single electrofusion manufacturer.</p> <p>Retitled the two remaining tables:</p> <p>PE2406/PE2708 - Medium Density PE Pipe - (Yellow) OFF of PE MAIN</p> <p>1. Added a 8"IPS x 2"CTS service - G331308</p> <p>PE2406/PE2707 - Medium Density PE Pipe - (Yellow) OFF of STEEL MAIN</p> <p>1. Added a 8"IPS x 2"CTS service</p> <p>PE3408/PE4710 - High Density PE Pipe - (Black) OFF of PE MAIN</p> <p>1. Added a 8"IPS x 2"CTS service</p> <p>PE3408/PE4710 - High Density PE Pipe - (Black) OFF of STEEL MAIN</p> <p>1. Corrected Transmission Fitting to PE3408/PE4710 to Steel</p> <p>Grammatical revisions for consistency in the designation of the medium density PE: PE2406/PE2708 and high density PE: PE3408/PE4710</p>	July 1, 2012	April 1, 2013
SERV 3.06	<p>Farm Tap, Single Cut, 60 - 450 PSIG Inlet Pressure:</p> <p>Relocated the high side pressure tap threadolet downstream of valve tee</p> <p>Item 15: Upgraded to Series 1100 EFV on the 1" service</p> <p>Note: Item 1: Added sentence: "Maximum wall thickness that Mueller H-18101 can tap is 0.281 inches"</p> <p>Grammatical revisions for consistency in the designation of the medium density PE: PE2406/PE2708 and high density PE: PE3408/PE4710</p>	January 1, 2013	April 1, 2013
SERV 3.07	<p>Farm Tap, Double-Cut, 451 - 1000 PSIG Inlet Pressure:</p> <p>Standards Committee eliminated the need for two double cut farm tap standards by utilizing the 1" Mueller H-17900 valve in the Standard Design. Moved the farm tap drawing and material list from SERV 3.08 to SERV 3.07.</p> <p>New Standard includes relocating high side pressure tap threadolet from below the valve to above the valve.</p> <p>Item 12: A 3/4" x 2" Schedule 80 nipple is used between steel tee and relief valve.</p> <p>Item 20: Upgraded to Series 1100 EFV on the 1" service</p> <p>Item 21: Corrected the stock codes for the electrofusion couplings.</p> <p>Item 22: A 3/4"x 6" Schedule 80 nipple is used between the Mueller H-17900 valve and the first cut regulator.</p>	January 1, 2013	April 1, 2013
SERV 3.08	DELETED: Farm Tap, Double - Cut, 741 - 1000 PSIG Inlet Pressure Standard Design. Now included in SERV 3.07.	January 1, 2013	N/A

<p>VALV 3.01</p>	<p style="text-align: center;">Plastic Ball Valves</p> <p>1. B.: Added new: "Kerotest, Lyall-Polytec, and Broen are approved manufacturers for all polyethylene ball valves.</p> <p>3.: Polyethylene Full Port Ball Dimensions</p> <p>Divided the information into two tables 1) PE2406/PE2708, MDPE and 2) PE3408/PE4710, HDPE ball valves. Listed information for all three manufacturers in each table.</p>	<p>October 1, 2011</p>	<p>April 1, 2013</p>
----------------------	--	----------------------------	--------------------------

Supersedes: January 1, 2013

CHANGE SUMMARY

January 1, 2013

Change Summary January 1, 2013

Docu- ment	Change Summary	Previous Docu- ment Dated	Current Docu- ment Dat- ed
ABND 0	<p>ABND 2.01 4. Added Verification of Mains or Service Status</p> <p>ABND 2.01 5. Added Records</p> <p>New: ABND 4 Reference 01 Continental Abandonment Kit Instructions</p>	October 1, 2011	Janu- ary 1, 2013
ABND 2.01	<p>Abandonment of Gas Facilities has been totally re-vised and should be reviewed with all gas personnel. The ICC requested an expansion of the abandonment procedures. This section has been divided into five sections: Mains, Services, Inside Meter, Verification of Main or Service Status, and Records.</p> <p>Main was divided into General abandonment proce-dures and then specific procedures for PE Mains, Steel Mains, and Regulator Stations.</p> <p>Service was divided into General abandonment pro-cedures and then specific procedures for PE Services from PE Mains, PE Services Lines with Compression Outlet Tees, Steel Service Lines, and Farm Taps.</p> <p>Inside Meter section contains procedures for aban-doning service lines entering a structure below and above grade.</p> <p>Verification of Main or Service Status has procedures for determining if a main or service line is active, dead, or inserted. This section was added at the re-quest of the ICC.</p> <p>Records is a new section that contains the mapping of service stubs 18 inches or longer that was original-ly under the Services section. Documenting abandon-ment of a Main has been added. Service abandon-ment is recorded on Service Record Cards or Service Transaction Form. Abandonment record will docu-ment leak testing of the cap installed on the remain-ing pressurized main or service line. Reference to the Buried Pipe Examination Form was added. A new screen print of a mapped service stub has been added that is easier to read.</p>	January 1, 2011	Janu- ary 1, 2013
ABND 4	<p>New: Added Reference 01 - Continental Abandonment Kit Instructions</p>		Janu- ary 1, 2013

ACIG 1	<p>2.: Sources of Ignition</p> <p>2. B.(1): Added flashlights to the list of items that are to intrinsically safe so they are not a potential source of ignition. Added reference to the Special Tools and Equipment site in the Gas Operations and Services home page in Scholar for approved intrinsically safe lighting equipment.</p>	October 1, 2011	Janu- ary 1, 2013
ACIG 2.01	<p>Work Area Protection</p> <p>2: Tools and Equipment</p> <p>2. A.: Added flashlights to the list of items that are to intrinsically safe so they are not a potential source of ignition. Added reference to the Special Tools and Equipment site in the Gas Operations and Services home page in Scholar for approved intrinsically safe lighting equipment.</p>	October 1, 2011	Janu- ary 1, 2013
BORE 1	<p>1. C.: Deleted the sentence: "Boring is the most efficient and effective way to install gas pipeline under highways, streets. Driveways, parking lots, railroads, streams or ditches, landscaping, well manicured lawns, and other surface obstacles." Was not relevant to procedures.</p>	January 1, 2011	Janu- ary 1, 2013
BORE 2.04	<p>Boring Across or Near Sewer Lines;</p> <p>1. C.: Replaced " gas main" with "gas line"</p> <p>2. D.: In Pre-Construction Steps added "high risk sewer laterals" to items to visually check for at the jobsite</p> <p>2. E.: Removed "Regardless of which step is taken, the only way to verify location and depth of sewer main or lateral is by physically exposing the line."</p> <p>Incorporated the original 2. F. into 2. E.</p> <p>2. E. (5): Added reference to "BORE 2.05" for assistance in identifying high risk sewer laterals.</p> <p>2. E. (6): New item added "The use of camera inspection for high risk sewer laterals is required unless sewer lateral is located and exposed prior to construction."</p> <p>2. G.(2): Replaced "affected sewer lines" with "high risk sewer lines".</p> <p>3. Camera Inspection of High Risk Sewer Laterals is a new section that has been inserted. A. Camera inspection of sewer lines applies to new construction and replacement projects.</p>	April 1, 2012	Janu- ary 1, 2013

B. High risk sewer lateral is defined as a sewer lateral that is within two (2) feet of the proposed gas facility.

C. High risk sewer laterals that are not located and exposed prior to construction shall be inspected by camera pre and/or post installation of the gas facility.

D. Examples of high risk sewer laterals are shown in BORE 2.05.

4. Construction Steps 4. B.: Deleted "Utilities that may conflict with the proposed drill path shall be exposed." Was covered in 4.C.

4. H.: Changed "are conducted" to "were conducted" in the section regarding hanging door tag.

4. J. New item "The use of camera inspection for high risk sewer lateral is required unless sewer lateral is located and exposed prior to construction."

7. Informational Letter has been updated

8. A.: Word corrections "residents"

8. B.: Added "instructed" - "Resident is instructed to call Ameren Illinois"

BORE
2.05

Typical Sewer Installations

Identified for each typical installation which ones are considered "high risk" and would be candidate for camera inspection.

Those considered high risk are:

Typical 2. Elevated Lot - Outside Cleanout

Typical 3. Original Sewer Abandoned - New Sewer Connected into Old Sewer at Curb

Typical 4. Very Elevated Lot

Typical 5. Home with Basement - Sewer Lift Pump Required

Typical 6. Elevated Lot - Rear Walkout- Sewer Exits Through Sidewall

Typical 8. Level Lot - Home on Slab- Outside Cleanout

Typical 9. Home on Slab - Shallow Sewer Lateral - No Outside Cleanout

Typical 10 Home on Slab - Very Elevated Lot

Typical 11. Home with Crawl Space - Shallow Sewer Lateral

January 1,
2011

January 1,
2013

Typical 12. Home on Slab - Very Elevated Lot

CONS
0

Added CONS 1 9. Operations and Maintenance Projects

January 1, 2011

January 1, 2013

CONS
1

Requirements

January 1, 2012

January 1, 2013

1. A.: Updated group name: Illinois Construction Services - Construction Supervisor. This the group that oversees all of the gas contractors in Illinois.
2. A.: Revised wording on when Gas Control should be contacted when Ameren crews are performing work. "When construction activity could potential affect the normal operating parameters of a gas system or facility monitored remotely by SCADA or ERX....."
2. A. (1) thru (7): Added a list of example construction activities that could have a potential for affecting normal operating parameters. (1) Installing control fittings and shutting-off gas flow to a section(s) of main.
- (2) Connecting two mains that could be operating at two different pressures.
- (3) Isolate or temporarily by-passing a pressure control station/gas system(s).
- (4) Activating a new, rebuilt, or relocated pressure control station.
- (5) Uprating a system or sections of a system.
- (6) Repairing a gas main that involves lowering the operating pressure during the repair process.
- (7) Activating a significant extension to an existing system. Gas Engineer or Gas Engineering will determine what is a significant extension. 3. A.: Revised wording on when Gas Control should be contacted when Contract crews are performing work. "When construction activity could potential affect the normal operating parameters of a gas system or facility monitored remotely by SCADA or ERX....."
3. A. (1) thru (7): Added a list of example construction activities that could have a potential for affecting normal operating parameters. (1) Installing control fittings and shutting-off gas flow to a section(s) of main.
- (2) Connecting two mains that could be operating at two different pressures.
- (3) Isolate or temporarily by-passing a pressure control station/gas system(s).
- (4) Activating a new, rebuilt, or relocated pressure control station.

- (5) Upgrading a system or sections of a system.
 - (6) Repairing a gas main that involves lowering the operating pressure during the repair process.
 - (7) Activating a significant extension to an existing system.
- Gas Engineer or Gas Engineering will determine what is a significant extension

3. Replaced Construction Supervisor with Illinois Construction Services - Construction Supervisor throughout the section.

3. D. thru F: These requirements were added since they not only applied to work performed by Ameren crews but also to Contract crew. D. Gas Supervisors or Illinois Construction Services - Construction Supervisor must ensure that gas field personnel are qualified to perform construction activities in accordance with the O&M Plan.

E. Gas Supervisors or Illinois Construction Services - Construction Supervisor/Construction Inspector shall physically verify that gas construction activities meet the requirements of the O&M Plan through observation of gas construction activities in the field.

F. Immediate corrective action will be taken by the Gas Supervisor or Illinois Construction Services - Construction Supervisor/Construction Inspector if any gas construction activities are found to be out of compliance with the O&M Plan.

4. A.: Minor grammatical revision by adding (s) to contractor and construction site to indicate there could be more than one.

5. A.: Modified some of the Major areas of focus associated with contractor oversight.

5. A. (3): Specifies purging of main

5. A. (4): Specifies pigging of main

5. A. (6): Specifies steel coating inspection by jeeeping as a Major activity.

5. A. (7): Added Liquid epoxy coating application as a Major activity.

5. A. (8): Clarification that inspector should be present when the initial welding and/or plastic fusion commences. Then inspector should periodically check on the welding and/or plastic fusion processes to ensure they are being correctly performed.

5. A. (9): Added "ensuring proper depth of cover" when inspecting backfilling.

5. B. & C: Added "Periodically" to indicate the inspector should perform and document a quality assurance inspection when major activity is being performed.

UNCONTROLLED IF PRINTED

The completed QA inspection form is then submitted to the Superintendent Quality Assurance.

9. Operations and Maintenance Projects

New section added to address small projects that could be scattered out such as tapping/stopping, lowering of main, installation of regulator or odorizer station, leak repair, service cut-offs, service riser replacements.

CONS 2.01	<p>Construction Inspector Responsibilities</p> <p>4.: Existing Facilities:</p> <p>4. B.: Added "JULIE 811" to replace "appropriate" for the one call system.</p> <p>6. Safety:</p> <p>6. A.: Replaced "all Ameren Illinois Safety rules" with "Ameren Illinois O&M Plan."</p> <p>6. B.: Inserted "when required" for the use of barricades, warning signals, and flagmen. Added reference to the IDOT Traffic Control Standards that are attached to highway permits.</p> <p>7.: Daily Routine and Check Points for Contractors</p> <p>7. A.: Replaced "standards" with "O&M Procedures". Inspector is ensure contractor is performing work in accordance with the Ameren Illinois O&M Plan.</p> <p>8.: Records</p> <p>8. A.: Revised the location of anodes, test lead wire boxes, insulators, valves, and other appurtenances installed during construction are recorded "accurately on the As Built construction drawings. Measurements are required so these facilities can be recorded in the electronic mapping system."</p> <p>8. I.: Added "pressure tests" to the list of records that are submitted to the Gas Supervisor and/or Gas Operations & Services - Engineering.</p>	October 1, 2011	January 1, 2013
CORR 0	<p>CORR 2.11 3M Scotchkote Hot Melt Patch Compound has been deleted</p> <p>CORR 2.29 Moved the Remedial Action and Corrosion Tracking in GCS into Reference document.</p> <p>New CORR 3.16 : AC Stray Current Test Station</p> <p>CORR 4 added Reference 13 - Corrosion Tracking in DOJM and GCS</p>	July 1, 2012	January 1, 2013

CORR 1	<p>Requirements</p> <p>6.: Internal Corrosion</p> <p>6. E.: Added "See Gas Storage O&M of Internal Corrosion Monitoring procedures in the gas storage fields."</p> <p>7.: Cathodic Protection Monitoring</p> <p>7. B.: In Isolated Service Lines deleted "pressure systems". Isolated service line sampling is based on 10% isolated services in a community.</p> <p>7. B. Tables: Replaced "Systems" with "Community"</p> <p>7. C.: In Isolated Mains Less than 100' deleted "pressure system". Isolated main less than 100' sampling is based on 10% isolated mains in a community.</p> <p>7. D.: In Isolated Fittings deleted "pressure system". Isolated fittings sampling is based on 10% of isolated fittings in a community.</p> <p>12. D. (3): Replaced "approved cold applied tape" with "approved coating" for repairing disbonded coating.</p>	October 1, 2011	January 1, 2013
CORR 2.01	<p>Cathodic Protection Design</p> <p>3.: Electric Isolation 3. A.(3): Added new item: "OVP lightning arrestor (stock code 49 22 423) installation can be considered where lightning and voltage surges are anticipated. See CORR 2.25" 3. A.(4): Added new item: "OVP lightning arrestors should be used across insulation points inside buildings where a combustible atmosphere is anticipated."</p> <p>4.: Insulating Points</p> <p>4. D.(5): New item in the bonding procedure was added: "Extending New Plastic from End of Existing Steel" drawing shows test lead off of steel and tracer wire with Plastic tied into test station. Indicates location of anodes.</p> <p>4. D.(6): New item in the bonding procedures was added: "New Plastic Installed Between Two Sections of Existing Steel". Drawing shows test leads and tracer wire connection at test station and location of anodes to be installed. Contains a note that the use of plastic between two sections of steel should be reviewed by engineering and corrosion control personnel. Consideration should be given to using steel pipe.</p> <p>4. D.(7): New item in the bonding procedures was added: "Relocating Existing Steel with Plastic". Drawing shows test leads and tracer wire connection at</p>	January 1, 2011	January 1, 2013

test station and location of anodes to be installed. Contains a note that the use of plastic between two sections of steel should be reviewed by engineering and corrosion control personnel. Consideration should be given to using steel pipe.

CORR 2.03	<p>Coatings</p> <p>1. A. (2)(a): Clarified the initial layer of FBE coating is approximately 14 mils and the second layer of abrasive resistant over coating is approximately 15 to 20 mils thick.</p> <p>1. A. (2)(a): Added "approved moisture cured wrap" as an alternative to sacrificial hot wrap for covering liquid epoxy coating on girth welds. Corrosion control group will be evaluating moisture cured wraps in 2013.</p> <p>1. A. (2)(b): Added to the pipe coating requirement for distribution pipe 2" and larger being installed by directional boring. "Dual coating would be the same as transmission and high pressure distribution pipe." Added "approved moisture cured wrap" as an alternative to sacrificial hot wrap for covering liquid epoxy coating on girth welds.</p> <p>1. A.(2)(c): Added "approved moisture cured wrap" as an alternative to sacrificial hot wrap for covering liquid epoxy coating on girth welds.</p> <p>1. C.: Eliminated the use of epoxy melt stick for coating repair.</p> <p>1. F. (1): Clarified when repairing disbonded coating on a service riser the wrap should extend to the bottom of the meter valve.</p> <p>1. F.(2) New item added: "Non-wax based cold applied tapes shall be used on risers for new construction where significant settling of adjacent soil is expected."</p> <p>4.: Removed 3M Hot melt patch sticks from Approved Field Applied Epoxy Coating.</p> <p>5. Approved Cold Applied Wax Tapes</p> <p>5. D.: Denso Color Tape products are being replaced with Tapecoat TC Color Coat wax tape products. The current supply of Denso Color Tape products are approved for continued use until supply is depleted.</p>	July 1, 2012	January 1, 2013
CORR 2.04	<p>2. A.: Added "Do not use torch to dry primer." Clarification that primer should be allowed to dry naturally prior to applying hot wrap. Torch can be used to dry or heat the pipe prior to applying the primer but not after primer has been applied.</p>	February 1, 2010	January 1, 2013

CORR 2.05	2. B. Added "Allow primer to dry naturally, do not use a torch to dry primer." Clarification that primer should be allowed to dry naturally prior to applying Tapecoat 20. Torch can be used to dry or heat the pipe prior to applying the primer but not after primer has been applied.	January 1, 2011	January 1, 2013
CORR 2.09	<p>Protal 7200:</p> <p>2. A. thru C.: Replaced "MBX Bristle Blaster" with generic "metal blasting tool".</p> <p>2. C. (1): Added "Ensure air is moisture and oil free." when using a grit blaster to clean metal for Protal 7200.</p> <p>2. F (4): Deleted specifying Denso brand for the foam pad trowels.</p> <p>2. I (1): Deleted the use of hot melt epoxy patch sticks for repair of Protal 7200 coating. Protal 7200 is to be used to repair coating.</p>	April 1, 2012	January 1, 2013
CORR 2.10	<p>Protal 7125:</p> <p>2. A. thru C.: Replaced "MBX Bristle Blaster" with generic "metal blasting tool".</p> <p>2. C. (1): Added "Ensure air is moisture and oil free." when using a grit blaster to clean metal for Protal 7125.</p> <p>2. F.(4): Deleted specifying Denso brand for the foam pad trowels.</p> <p>2. I.(1): Deleted the use of hot melt epoxy patch sticks for repair of Protal 7125 coating. Protal 7125 is to be used to repair coating.</p>	January 1, 2011	January 1, 2013
CORR 2.11	Deleted 3M Scotchkote Hot Melt Patch Compound 226P as an approved coating repair product. CORR 2.11 is being left blank for the time being.	April 1, 2012	January 1, 2013
CORR 2.13	<p>Trenton No 2A Wax Tape</p> <p>2.: Application</p> <p>2. C. and D.: Deleted specifying "Glas-Wrap" brand for the mesh outer wrap. There are other mesh wraps available</p>	July 1, 2012	January 1, 2013
CORR 2.15	<p>Coating Inspection</p> <p>2. B.: Revised the Expected Average Thickness and the Test Voltage for the FBE Coating with Abrasive Resistant Layer (dual coated pipe).</p> <p>6.: Coating Repairs</p>	April 1, 2012	January 1, 2013

	6. B.: Deleted reference to defects larger than 1/16". All coating defects can be repaired in the same manner.		
CORR 2.16	Measuring Cathodic Protection Potentials 4. B.: Added Note with Ameren Stock Code for replacement Porous Plug 4. B.(6)(e); Added stock codes for replacement Copper Sulfate Crystals and Anti-freeze for the Copper Sulfate Reference Electrode.	January 1, 2011	January 1, 2013
CORR 2.29	Records 1.: New, added a General section CORR 2.29 has been substantially reduced in size by moving the OAS and GCS instructions into a reference document that is now in the Forms and Reference Materials section 4.: Other Cathodic Protection Record Activities 4. A.(1): Added a reference to CORR 2.30 which is the Buried Pipe Examination Form instructions. 4. A.(5): Added the mailing address for Gas Operations and Services - Pipeline Integrity group.	July 1, 2012	January 1, 2013
CORR 2.30	6.: Updated the Flow Chart for Processing Buried Pipe Examination Form	April 1, 2012	January 1, 2013
CORR 2.31	5.: Updated the Flowchart Buried Pipe Examination - Corrosion and Steel Damage Evaluation	October 1, 2011	January 1, 2013
CORR 3.16	New standard for AC Stray Current Test Station		January 1, 2013
CORR 4	Added Reference 13 - Corrosion Tracking in DOJM and GCS	October 1, 2011	January 1, 2013
DAMG 1	Requirements 5. Damage Prevention Notification to Excavators and General Public: 5. A.: Added "Maintenance of lists and coordinating notifications is handled jointly by Damage Prevention and Public Awareness groups." 5. B. Added "Agricultural Field Tile Contractors" to firms that will receive annual notification.	April 1, 2012	January 1, 2013

5. C.: Public Awareness information has been added with regards to Damage Prevention Notification to Excavators and the General Public: "Ameren Illinois will maintain a list of known excavators and field tiling contractors that could operate within Ameren Illinois territory. The list will be developed from various sources including state contractor licensing boards, local associations, JULIE, and Ameren Illinois operating areas. The list will be reviewed and updated annually"

5. D.: "Ameren Illinois will distribute the notification annually to the known excavators and field tiling contractors that are on the list."

5. E.: "Ameren Illinois developed an Excavator Handbook and Farming Brochure that will be distributed to excavators and field tiling contractors."

6. C.: Added if blasting activity is within 100 feet of a gas facility the inspection must include a leak survey.

EMER 0	<p>Added EMER 2.04 1. General</p> <p>Revised EMER 2.04 7. to Explosion and/or Fire Near Gas Pipeline Facilities</p> <p>EMER 4: Added Form 03 - Ameren Shipping Paper for CNG to the forms section</p>	July 1, 2012	January 1, 2013
EMER 2.04	<p>Gas Field Personnel</p> <p>1.: Added a General section</p> <p>2. Inside Odor Complaint - Hazardous Condition</p> <p>2. A.: Grammatical revisions: "Evacuate the structure, ask occupants to leave the structure immediately."</p> <p>2. C.: Clarified "safe distance away from the structure" when instructing occupants to vacate a structure. 2. D.: Combined former 1. E. (1) thru (4) into one sentence "Contact Ameren Illinois Dispatcher and/or Gas Supervisor - request additional assistance and request they contact proper authorities such as Fire Department, Police Department, electric and other affected utilities, etc.</p> <p>2. J.: Revised to: "Ventilate the structure only after external sources have been disconnected." Eliminated instruction to open doors.</p> <p>2. L. (1): Revised if gas is found when bar testing or leak surveying surrounding mains and services, a complete leak investigation as outlined in LEAK 2.02 is to be performed.</p>	October 1, 2011	January 1, 2013

2. L. (2): Grammatical change, replaced "Proceed to" with "see EMER 2.04 4."

3. Outside Odor Complaint - Hazardous Condition

3.: Revised: "When gas is detected outside of the structure, a reading of 30% LEL (1.5% gas in air) or greater in the open atmosphere where gas could enter a structure or ignition sources are in close proximity is considered a hazardous condition."

3. A.: Grammatical revision: "Evacuate the affected area."

3. B.: Inserted new: "Continue to monitor gas concentration with the CGI." (ICC)

3. C.: Clarified "Make sure no vehicular equipment is operated within the affected area." 3. D.: Combined former 1. C. (1) thru (4) into one sentence "Contact Ameren Illinois Dispatcher and/or Gas Supervisor - request additional assistance and request they contact proper authorities such as Fire Department, Police Department, electric and other affected utilities, etc."

3. G.: Grammatical change, replaced "Proceed to" with "see EMER 2.04 4."

3. H.(1): Grammatical change "structure(s)'

3. I.: Added new item on use of non-emergency valves: "If a non-emergency valve is used to control gas during an emergency situation, the valve will be designated as an Emergency Valve after the emergency situation has been resolved. See VALV 2.01"

3. I.(4): Added as a means of isolating a section of main: "Construct a by-pass around damaged area and isolate damaged section."

4. Major Leaks or Line Breaks

4. B.: Combined former 3. B. (1), (2), (5), (6) into one sentence "Contact Ameren Illinois Dispatcher and/or Gas Supervisor - request additional assistance and request they contact proper authorities such as Fire Department, Police Department, electric and other affected utilities, etc."

4. F.: Added new item on use of non-emergency valves: "If a non-emergency valve is used to control gas during an emergency situation, the valve will be designated as an Emergency Valve after the emergency situation has been resolved. See VALV 2.01"

5. Gas in a Sewer - Hazardous Condition

5. B.: Combined former 4. B. (1) thru (4) into one sentence "Contact Ameren Illinois Dispatcher and/or Gas Supervisor - request additional assistance and request they contact proper authorities such as Fire Department, Police Department, electric and other affected utilities, etc."

5. D. (1): Eliminated repeating instructions to be given when evacuating a structure by referencing procedures in EMER 2.04 1. above.

5. G.: Added new item on use of non-emergency valves: "If a non-emergency valve is used to control gas during an emergency situation, the valve will be designated as an Emergency Valve after the emergency situation has been resolved. See VALV 2.01"

5. H.: Word changes so it reads: "Once the gas supply has been shut off, ventilate the structure after external ignition sources have been disconnected."

6. Fire, Ignition, or Explosion - Gas Related

6.: Revised wording to: When responding to a gas related fire, ignition or explosion our first priorities is are public safety and employee safety. The following steps will outline the appropriate actions.

6. B.: Combined former 5. B. (1), (2), (5), (6), (7) into one sentence "Contact Ameren Illinois Dispatcher and/or Gas Supervisor - request additional assistance and request they contact proper authorities such as Fire Department, Police Department, Ambulance, electric and other affected utilities, etc."

6. C.: Inserted new: Gas Supervisor shall notify the Gas Superintendent with a brief explanation of the situation and the types of gas facilities that may be affected.

6. D. (2): Replaced with: "If Fire Department has shut-off valve, if possible, visually verify the valve is off."

Former 5. D. (3): Removed " If cause of fire has not been determined or there is a possibility that gas is involve". Now states "Advise the Fire Chief or fireman in charge that a gas investigation will be required. See INVVE 2.02"

Former 5. G: Deleted " Assist Fire Department or responding emergency agency in providing minor first aid care to those injured, if requested"

Former 5. H.: Deleted "If Fire or Police personnel have not arrived, investigate if there are any missing persons associated with the situation."

Former 5. J.: Deleted "Gas Supervisor should make arrangements to pick-up copy of the Fire Report as soon as it is available. If situation required an Incident

UNCONTROLLED IF PRINTED

Investigation, Fire Report, if available, should be part of the documentation

7. Explosion and/or Fire Near Gas Pipeline Facilities

7. A.: Moved "explosion" ahead of "fire".

7. B.(1) & (2): Moved "explosion" ahead of "fire".

7.C.: Revised wording to: "If following the evaluation, there is concern that gas facilities may be impacted; gas field personnel should notify a Gas Supervisor."

7. D.: Added "fireman in charge " as another individual gas field personnel could contact.

7. E.: Grammatical change: "Gas Supervisor shall notify the Gas Superintendent with a brief explanation of the situation and the types of gas facilities that may be affected."

8. Low Pressure Situation

8. A.: Inserted new:" Pressure below 4" W.C. on low pressure systems and 2 PSIG on distribution pressure systems may cause pilot outage."

8. C.(4): Deleted "and/or relief valves" since low pressure would only result if ice covered regulator vents.

8. E.: Revised the steps to be taken when low pressure situation is discovered:

(1) Identify the extent and provide a general geographical location of the low pressure area.

(2) Request additional assistance if necessary.

(3) Determine if the low pressure will create a customer outage by checking the pressures at the extremities of the system. Check for pilot outages and close the meter valve for those customers affected if the pressure drops below a safe level.

(4) Utilize maps showing critical valves and pressure control stations to assist in isolating the area.

(5) Isolate the affected area to conserve pressure in adjacent areas.

(6) Discuss the possibility of bypass operations to stabilize the distribution pressure.

(7) Discuss possible curtailments of large use customers. 8. F.: Revised wording to: "Gas Supervisor should notify Gas Control if situation and advise on any assistance that is needed or can be provided with the affected system(s)."

9. High Pressure Situation

9. D.: Revised wording to: "Gas field personnel should immediately notify Gas Supervisor if the systems pressures are above the MAOP of the system."

9. E.: Revised wording to: "Gas Supervisor should notify Gas Control if situation and advise on any assistance that is needed or can be provided with the affected system(s)."

9. F.: New item: "Gas Supervisor or Gas Operations & Services - Gas Technical Services Supervisor should ensure an operator qualified regulator personnel or technician has been notified and dispatched."

9. H.: Grammatical change: "Use valves to throttle or shut down the feed to the system until the pressure is within the normal operating range."

9. J.: Clarified that following repairs normal operating pressure should be reestablished.

10. Loss and Restoration of Services

10. F(3): Deleted "confirm the extent of outage" when contacting Gas Control.

10. f.(4): Corrected it is Gas Operations and Services - Gas Technical Services Supervisor that should be contacted when transmission or high pressure distribution facilities are involved.

10. F.(6): Added "Affected" to clarify which industrial or commercial customers Gas Supervisor should notify of a loss of service.

10. H.: The threshold for contacting the IEMA is now 500 customers if they are going to be without gas for 24 hours or longer. Reduced from 1000.

10. M.(3): Added "Ameren Security personnel" to those who could witness a forcible entry and stand-by while work is performed inside the premise.

10. M.(7): Clarified: Claim Department is (CCMI).

10. R.: Revised wording to: "Gas Supervisor should notify Gas Control if situation and advise on any assistance that is needed or can be provided with the affected system(s)."

10. S.: Replace "local media" with Ameren Illinois Communication" as ones that should be updated on the restoration progress.

10. T.(4): Inserted new item: "Customer may choose to relight their own appliance unless the 30 second leak test fails."

10. T.(5): Delete the reference to using the stove to purge customer's piping.

10. T.(6): Revised wording to: "Light the pilots on the gas utilization equipment. Place the equipment into operation. Note: During the warmer times of the year the customer may not want their pilots lit on the space heating equipment"

10. T.(8): Added: "Claims Department (CCMI) may be utilized to process HVAC invoices." when pilots will not remain lit and Supervisor has to call an HVAC dealer to correct the problem.

10. W.(1): Replace "local media" with Ameren Illinois Communication" to update when restoration is complete.

EMER 2.10	6. D.: Specified Shipping papers for CNG 6. E.: Updated sample of Shipping Paper for CNG	July 1, 2012	January 1, 2013
EMER 4	Added Form 03 - Ameren Shipping Paper for CNG	January 1, 2011	January 1, 2013
FORW	4. G.: Added Gas Technical Services group to Gas Operations and Services	July 1, 2012	January 1, 2013
<u>GLOS</u>	Added the following definitions to the Glossary: Combination Leak and Strength Test Covered Task Leak Test Manufactured Home NDT _ Nondestructive Testing NFDP - New Facility Design Pressure Qualified Welder Qualified Welding Inspector Security Threat Levels Elevated Threat Level Imminent Threat Level Sunset Provision Strength Test Tie-In Test Welding Procedure Qualification Report (WPQR) Welding Procedure Specifications (WPS)	January 1, 2012	January 1, 2013

Modified definition of Polyethylene Pipe by adding the MAOP for medium density (PE2406/2708) and high density (PE 3408/4710)

Modified definition of Test Duration by adding "duration begins after test pressure has stabilized"

Deleted the following definitions:

Qualified Welding Procedures - Replaced with (WPQR)

Threat Level 1 (Green)

Threat Level 2 (Blue)

Threat Level 3 (Yellow)

Threat Level 4 (Orange)

Threat Level 5 (Red)

Welder - Replaced with Qualified Welder

Welding Specifications - Replaced with (WPS)

<u>INCD</u> <u>0</u>	INCD 1 10: Changed Corporate Communication to Ameren Illinois Communication	January 1, 2012	January 1, 2013
<u>INCD</u> <u>1</u>	10.: Replaced Corporate Communication Notification with Ameren Illinois Communication Notification Updated contact information by substituting Tucker Kennedy III for Sean Vanslyke's	July 1, 2012	January 1, 2013
INVE 0	INVE 2.01 inserted item 4. Chain of Custody Documentation	January 1, 2011	January 1, 2013
INVE 2.01	Incident Investigation: Inserted a New Section 4. Chain of Custody Documentation. Provides a procedure for documenting chain of custody of items removed or taken out of service that may have been involved in the incident. 7. C.: Revised this item under Preservation of Evidence: "Facilities removed should be tagged and stored in a secure location for a minimum of five (5) years unless the Legal Department provides written notification that the facilities may be disposed of or placed back in service." 7. D.: Added: "Tools and equipment removed from service shall be tagged and stored in a secure location until the investigation is complete. Equipment such as a trencher, backhoe or directional boring ma-	October 1, 2011	January 1, 2013

chine may be secured at the OC by removing the ignition key and tagged "Out of Service". Tools and equipment may be placed back in service once the investigation is complete and the Legal Department provides written notification that the tools or equipment may be placed back into service." 7. E.: Added: Once the facilities or tools and equipment are disposed of or place into service, the chain of custody documentation shall be placed in the incident investigation file.

INVE 2.02	Investigation of Fires 6.A.(1): Minor change replaced Corporate Communications with Ameren Illinois Communications	January 1, 2011	January 1, 2013
INVE 4	<p>Updated Form 01 - Gas Incident Investigation Log: Added "Other" to Company Facilities Removed and Tagged</p> <p>Added a new section: Company Equipment Taken Out of Service and Tagged that lists the following:</p> <ul style="list-style-type: none"> Combustible Gas Indicator Flame Ionization Unit Odorometer Pressure Gauge Pressure Recorder Pipe Locator Tapping/Stopping Equipment Electro Fusion Control Unit Butt Fusion Equipment Boring Machine Trenching/Plowing Machine Backhoe Machine <p>Other:</p> <p>Added New Form: Form 02 - Chain of Custody Log: Log of facility or equipment removed or taken out of service that may have been involved in the incident.</p>	January 1, 2011	January 1, 2013
LEAK 0	<p>LEAK 2.01: New Section Headings</p> <p>Inserted LEAK 2.01 3. Approaching Structure</p> <p>LEAK 2.01 4. Customer is Home</p> <p>LEAK 2.01 5. Customer Not Home or Can't Get Into Structure</p>	January 1, 2012	January 1, 2013

LEAK 2.02: New Section Headings

Inserted LEAK 2.02 3. Approaching Structure

LEAK 2.02 5. Below Grade Gas Facilities

LEAK 1	<p>Requirements</p> <p>2. D.: Inserted new item under Leak Investigations. "During a leak investigation, if a leak is detected, gas field personnel should perform a sniff test to check if odorant is readily detectable. See LEAK 2.03</p>	October 1, 2011	January 1, 2013
LEAK 2.01	<p>Indoor Leak Investigation:</p> <p>The Subject Matter Resource Team completed an intensive review of this section and has made numerous revisions. The entire section should be reviewed thoroughly with all gas field personnel.</p> <p>1. A.: Delete "is required" so sentence now reads "Ameren Illinois responds to all leak or odor complaints in a priority manner.</p> <p>1. B.: Added "and employee" so sentence now reads "The top priorities for an indoor leak investigation is to ensure public and employee safety."</p> <p>1. E.: Deleted "Any response time greater than one hour will be investigated." since it stated in LEAK 1.</p> <p>2. A.: Revised the minimum required equipment to only a Combustible Gas Indicator (CGI).</p> <p>2. D.: Revised to simply state "Confirm location".</p> <p>2. E. Moved into a new section "Approaching Structure"</p> <p>3. Inserted New section "Approaching Structure" Some items that were previously listed in "Customer Not Home" and "Customer Is Home" have been moved into this new section. 3. A.: Observe for indications of gas leakage:</p> <p>(1) Listen for the sound of escaping gas and smell for the odor of natural gas</p> <p>(2) Check the area for dead or dying grass, shrubs, or trees</p> <p>(3) Look for signs of recent construction activity that could have damaged gas facilities (4) If the meter is checked, observe test hand for rapid movement. If open fuel line is suspected shut-off meter valve. Before touching the gas meter, check meter set with volt stick.</p> <p>3. B.: Knock on the door Do Not ring the doorbell.</p>	April 1, 2012	January 1, 2013

4. Customer Is Home was moved ahead of Customer Not Home or Can't Get Into Structure.

5.: Previously 3. Customer Not Home is now 5. Customer Not Home or Can't Get Into Structure.

5. A.: Added "Check outside meter test hand for movement. If open fuel line is suspected shut-off meter valve and implement EMER 2.04."

Customer Is Home and Customer Not Home or Can't Get Into Structure sections have too many modification and revisions to list in this Change Summary. These sections should be reviewed in detail with all gas field personnel.

6. Leak on Customer Facilities: Deleted the distinction between "exposed customer facilities" and "inaccessible customer facilities" so any leak on customer facilities is now treated in the same manner.

6. A.: Indoor gas leak on customer facilities:

(1) Make simple repairs when possible

(2) If simple repair cannot be made then:

(a) Isolate the gas leak at the appliance control valve, customer owned valve, or meter set.

(b) Notify customer of the gas leak and advise customer they are responsible for making the repairs. Complete 6H screen and issue a Warning Tag. See TURN 2.11

6. B. If the gas leak is not an immediate hazard (i.e. soap bubble holds) an exception may be made due to cold weather conditions or a commercial/industrial process with the approval of the Gas Supervisor. Notify customer of the gas leak and advise customer they are responsible for making the repairs with the following option:

(1) The customer can immediately call a qualified plumbing or heating professional to make the repair and the Company will turn the leak over to them once they arrive. In the case of a commercial/industrial process that has their own in-house maintenance personnel, the Company will turn the leak over to the customer if maintenance personnel are immediately on-site.

(2) Complete the OAS 6H screen and issue Warning Tag. See TURN 2.11

7. A. In the Records section a minor clarification was added to make it clear that a Leak Investigation Form should be completed for all leaks on company facilities. The form can be completed on the MDT, 7. B.

LEAK
2.02

Outdoor Leak Investigation:

October 1,
2011

Janu-
ary 1,
2013

The Subject Matter Resource Team completed an intensive review of this section and has made numerous revisions. The entire section should be reviewed thoroughly with all gas field personnel.

1. A.: Delete "is required" so sentence now reads "Ameren Illinois responds to all leak or odor complaints in a priority manner.

1. B.: Added "and employee" so sentence now reads "The top priorities for an indoor leak investigation is to ensure public and employee safety."

1. E.: Deleted "Any response time greater than one hour will be investigated." since it stated in LEAK 1.

2. Upon Arrival:

2. A.: Minimum equipment for investigation was moved from the previous and deleted Equipment and Materials section. Minimum equipment for an investigation was reduced to an FI unit, CGI, or Gas Detection Instrument; Gas Leak Field Case Report form, and Probe or Drive Rod.

3. Inserted new section "Approaching Area" which contains a list of items to inspect the area for using the sense of sight, smell, and hearing. These were originally contained under the "Upon Arrival" section.

5. Changed title to Below Grade Gas Facilities from Subsurface Atmosphere Sampling.

5. A.: Added several more locations that should be considered when performing an investigation.

5. J.(4): Added "If you suspect migration to a structure(s), obtain additional samples inside. Refer to Hazardous Conditions section below."

7. A.(1): Under Hazardous Condition added a clarification on that implementation of the Emergency Plan may be required when there a 30% LEL or greater reading in the open atmosphere where gas could enter a structure or ignition sources are in close proximity.

7. C.: Added "If there is an indication of gas migration into a structure where gas field personnel cannot gain access, see LEAK 2.01 5. F. - Customer Not Home or Can't Get Into Structure.

8. A.(1): Added "Make simple repairs when possible" for leaks on customer owned facilities.

8. B.(1): Deleted "The Company will disconnect service until repairs are made" since it is really not an option up to the customer when there is a leak on

UNCONTROLLED IF PRINTED

their facilities. The option available to the customer is for them to have a HVAC/plumbing contractor or maintenance personnel immediately on site so Ameren gas field personnel can turn the leak over to them.

9. B.: Minor grammatical change by adding "make" - If using MDT make appropriate entries

LEAK
2.04

Leak Classification and Surveillance:

April 1, 2012

Janu-
ary 1,
2013

4. D.: In Leak Classification Criteria additional steps must be taken when a sustained reading of 2% LEL or less is obtained within 5 feet of a foundation. These additional investigation measures may include: 1) Rechecking the reading with a second CGI to verify a 0% LEL reading or 2) Physically digging up the service at the foundation and visually inspecting for a leak.

4. F. Added a new item: Any indication of a leak on relief valve facilities at a regulator station should be reported to Gas Tech Services Supervisor as soon as possible.

7. Venting a Leak has been revised for both below grade Class 1 within 5 feet of a foundation and a Class 1 found in a tunnel/sanitary sewer. Once reclassified to a Class 2, both situations daily surveillance is required and the leak must be repaired within 15 days. 7. A.: A below grade Class 1 leak where gas is detected 0 - 5 feet from a foundation may be vented as an immediate corrective action by physically digging up the gas facilities and allowing gas to vent to atmosphere. Once the readings 0 - 5 feet from the foundation are less than 2% Gas after venting:

7. A.(1): The leak may be properly reclassified to a Class 2 leak if the leak is no longer an immediate hazard nor is in imminent danger of becoming a hazard.

7. A.(2): However, the leak shall be repaired within fifteen (15) days and surveillance shall be performed each day until the leak is repaired.

7. B. A below grade Class 1 leak found in a tunnel/sanitary sewer may be vented by placing a slotted lid over the manhole and allowing gas to vent from the sewer to the atmosphere as immediate corrective action. Once the readings after venting are less than 4% gas:

7. B.(1): The leak may be properly reclassified to a Class 2 leak if the leak is no longer an immediate hazard nor is in imminent danger of becoming a hazard 7. B.(2): However, the leak shall be repaired with-

in fifteen (15) days and surveillance shall be performed each day until the leak is repaired.

10. Ameren Illinois Leak Classification Guidelines card has been revised. A new Volume category has been added: 0 to 4% LEL which applies only to Hazard Potentials; Entering Structure and 0' to 5' Foundation Wall. Volume category >2 % LEL to 4% Gas no longer applies to Hazard Potentials Entering Structure and 0' to 5' Foundation Wall.

The note on the card has been revised, "A reading of 2.0% LEL (0.10% gas) or less is considered 0% gas for leak classification/documentation purposes and is not a reportable reading if the reading is greater than 5 feet from a foundation wall.

11. C.(2)(a): Corrected Refer to 7. A.(2) to 7. C.(2).

12. A.(1): Removed "and/or leak detection fluid" from a method for performing a recheck of a repaired below grade leak. Verification of a recheck on a below grade leak can only be done with a CGI.

12. A.(3)(c): Added: Where residual gas is detected in the soil and the reading is 0 to 5 feet from a foundation wall, daily recheck shall be performed.

12. B. (1): Removed CGI, FI as a means for performing a check on above grade leak repair. Above grade leak repair can only be verified with leak detection fluid.

LEAK
2.05

Gas Leak Field Case Report:

October 1,
2011

January 1,
2013

2. B.(2): Under Volume a note has been added. Since the GLFCR cannot be modified at this time a note has been added to address the change in gas concentration for leak "Entering Structure" or "0' to 5' Foundation". The limit is now 0% LEL to 4% LEL. On the GLFCR, the >2 LEL to 4% Gas will have to be marked.

2. B.(4): Under Surveillance Data, Verification Method added "Above Grade leak can only be verified with, "Soap", leak detection fluid.

2. B.(5): Removed ", "

2. B.(7): Under Reasons for uprating added "multiple public calls" to list of reasons why a leak is being uprated.

2. C.(3)(d): Under Repair Data, Pressure Test Data for Pipe Replaced/Srv Disconnected added abandoned or retired service lines when the box should not be checked.

2. C.(5): Under P/S Reading added "Entry is no longer needed. P/S Reading is required to be entered

UNCONTROLLED IF PRINTED

on Buried Pipe Examination Form and entered in PEET.

2. C.(6): Added the word "back" to clarify that a cut service line is to be FI from the cut back to the main.

2. C.(7): Service Main External and Internal Corrosion Exam: Added "This section does not replace Buried Pipe Examination Form."

2. C.(8)(a): Minor word change "above grade piping" replaced "above ground piping" under Leak Cause - Corrosion.

2. C. 8)(d): Minor word change "above grade facilities" replaced "above ground facilities" under Leak Cause - Outside Force.

2. C.(8)(g): Added "(Incorrect Operation)" after Operations under Leak Cause. Annual DOT Report now contains "Incorrect Operations" instead of "Operations".

2. C.(12); Under Pressure added (MAOP 20% SMYS or greater) to define a Transmission gas main.

2. C.(13): Under Remarks added "Note if soap, leak detection fluid, was used to check repair for leaks ."

2. D. Leak Recheck: Minor word change "below grade leaks" replaces "below ground leaks"

LEAK 2.06	Leak Process Flow Charts Updated Below Grade Gas Leakage - Class 1 to reflect the new procedures when a Class 1 leak 0 to 5 feet from foundation or in a sewer is vented.	January 1, 2011	Janu- ary 1, 2013
LEAK 2.08	Leak Surveys - Equipment 2. G.: Inserted new item under Flame Ionization Instrument - Portable: "If FI unit is being utilized on daily basis for leak survey activity, the unit should be checked at the conclusion of the day's activity to verify the unit is still operating properly."	July 1, 2012	Janu- ary 1, 2013
LEAK 2.09	Walking Leak Survey: 1. J.(5): Added "large commercial/industrial meter sets, or extensive above grade piping facilities" that may require longer than a two second sweep when leak surveying 1. K.(2): Deleted "Regulator Station" from the list of fenced gas facilities. Leak surveying of fenced regulator station is addressed separately in the revised 1. K. (5) 1. K.(4): Removed "annual" so that leak survey of buried or above grade facilities in a fenced area may	April 1, 2012	Janu- ary 1, 2013

be performed during maintenance inspection and recorded in GCS.

1. K.(5): Replaced with language for fenced regulator stations: "Buried gas facilities an above grade facilities within a fenced area of a regulator station will be leak surveyed during the annual maintenance inspection and recorded in GCS."

LEAK 2.13	<p>Calibration of Gas Detection Instruments</p> <p>1. C.: Minor grammatical change: replaced "policy" with "procedure".</p> <p>5.: Changed section heading to "CGI Operational Checks" for CGI Daily Operational". Revised this entire section to</p> <p>5. A.: Daily or Prior to Use:</p> <p>5. A.(1) Follow manufacturer's operating procedure for inspection:</p> <p>5. A.(1)(a) Visually inspect the instrument for dirty filters, damaged components, or missing parts</p> <p>5. A.(1)(b) Check the sampling system for leaks</p> <p>5. A.(1)(c) Check for low battery display or indication</p> <p>5. A.(1)(d) Zero the sensors</p> <p>5. B.: New item: Weekly verify sensors are functioning by:</p> <p>5. B.(1): Exposing instrument to a source of natural gas or bump gas or</p> <p>5. B.(2): Registering a gas concentration during a leak investigation.</p>	January 1, 2011	January 1, 2013
LOCT 0	LOCT 4: Updated Form 01 - JULIE Locate Request Form	January 1, 2011	January 1, 2013
LOCT 4	Updated Form 01 - JULIE Locate Request Form Rev 1-1-2012 in the Forms and Reference Materials	January 1, 2011	January 1, 2013
<u>MAIN</u> <u>1</u>	<p>3. A. Table: Revised the Minimum Cover Requirements for Distribution Mains & High Pressure Distribution Mains to 30 inches from the previous 24 inches.</p> <p>3. B.: Revised this item to: Where the required minimum cover cannot be maintained, Safety Barrier Tape (Stock Code 19 06 958) shall be installed approximately twelve (12) inches below the surface to provide advance warning to excavators.</p>	July 1, 2012	January 1, 2013

3. C.: Inserted new: Additionally, mains that may be subjected to anticipated external loads must be provided with additional protection. Gas Engineering will specify additional protection methods. Location of main with this additional protection should be recorded on the appropriate gas system maps.

3. D.: Added that in cultivated areas Gas Engineering will specify additional depth requirements. 3. E.: New item: Where gas carrying appurtenances are attached to existing mains, the appurtenance should have a minimum of twenty four (24) inches cover. Where the minimum cannot be provided, Safety Barrier Tape shall be installed approximately twelve (12) inches below the surface to provide advanced warning to excavators.

METR 0	<p>Updated METR 2.10 revised subsection descriptions</p> <p>New Section METR 2.26: New Meter Testing</p> <p>Changed name of METR 3.06 to Regulator Sizing - 10 PSIG Delivery Pressure</p> <p>Changed the previous METR 3.06 thru METR 3.23 to METR 3.07 thru METR 3.24</p> <p>Forms: Updated Form 03 - Gas Meter Data Sheet</p> <p>Reference Materials: Updated Reference 05 - Fisher CS800 Series Instruction Manual January 2012.</p> <p>Added Reference 06 - Fisher CS400 Series Instruction Manual March 2012</p>	July 1, 2012	January 1, 2013
METR 2.04	<p>Periodic Meter Testing</p> <p>Replaced "proof test" with "accuracy test" throughout the document</p>	April 1, 2011	January 1, 2013
METR 2.07	<p>1. C.: Added "Bell provers are not currently utilized at Ameren Illinois for testing gas meters."</p>	January 1, 2011	January 1, 2013
METR 2.11	<p>Contract Meter Repair:</p> <p>2. B.(4): Replaced "Proof testing" with "Accuracy testing"</p>	January 1, 2012	January 1, 2013
METR 2.12	<p>Rotary Meter Differential Testing:</p> <p>4. D.: Added a sentence: "The presence of an electronic index to display flow rate could eliminate the need for a clock or stop-watch."</p>	January 1, 2011	January 1, 2013

METR 2.13	Turbine Meter Testing: Replaced "proof test" with "accuracy test" throughout the document	October 1, 2011	Janu- ary 1, 2013
METR 2.14	Electronic Corrector Inspection: 6. C.(2): Battery Maintenance: added "Lithium batteries" to "Wake Cycles"	April 1, 2012	Janu- ary 1, 2013
METR 2.16	Gas Meter Data Sheet: 3. A.: Updated by stating the completed Gas Meter Data Sheet shall be forwarded, electronically or paper copy to the appropriate local office and appropriate Gas Meter Supervisor. Copy no longer is sent to Gas Operations and Services. 3. B. (1): Added the End User Transportation Managing Supervisor to distribution for gas transmission customers. Included mailing address. 3. B. (2): Added Illinois CAD to distribution when there is a potential for billing adjustments. Included mailing address.	January 1, 2012	Janu- ary 1, 2013
METR 2.26	New Section: New Meter Testing This section applies to the Gas Meter Shop personnel who test new gas diaphragm meters		Janu- ary 1, 2013
METR 3.01	New Meter Sizing 1. A.: Revised when Gas Engineering or Ameren Illinois Metering is to be contacted for selection and approval of meters larger than 7M/175. Increased the delivery pressure to 10 psig or the connected load is greater than 10,000 scfh.	April 1, 2012	Janu- ary 1, 2013
METR 3.02	Existing Meter Sizing: 1. B.: : Revised when Gas Engineering or Ameren Illinois Metering is to be contacted for selection and approval of meters larger than 7M/175. Increased the delivery pressure to 10 psig or the connected load is greater than 10,000 scfh. 3.: Tables & Note: Combined the Notes into one set at the end of the Tables. Note 2 revised for Capacities above 7" WC are for 2"WC pressure drop across the meter.	January 1, 2012	Janu- ary 1, 2013
METR 3.03	Regulator Sizing - 7" W.C. Delivery Pressure: 1. B.: Replaced "regulator capacities greater than 10,000 cfh" with "connected loads greater than 10,000 scfh" when gas engineering or Gas Opera-	April 1, 2012	Janu- ary 1, 2013

UNCONTROLLED IF PRINTED

tions and Services are to be contacted for selection and approval of regulators.

2.: Note 3 below table: Changed the monitor spring, monitor set point and token relief set point for the Fisher CS803-IT regulator.

METR 3.04	<p>Regulator Sizing - 2 PSIG Delivery Pressure:</p> <p>1. B.: Replaced "regulator capacities greater than 10,000 cfh" with "connected loads greater than 10,000 scfh" when gas engineering or Gas Operations and Services are to be contacted for selection and approval of regulators.</p> <p>2. Notes: Note 5. Changed Monitor Spring description to Dark Blue with Spring Range of 3.6 to 6 psig.</p>	April 1, 2012	January 1, 2013
METR 3.05	<p>Regulator Sizing - 5 PSIG Delivery Pressure:</p> <p>1. B.: Deleted customer delivery pressure greater than 5 psig as a requirement for contacting gas engineering or Gas Operations and Services for selection and approval of regulators. Now engineering should be contacted when the connected load is greater than 10,000 scfh.</p>	April 1, 2012	January 1, 2013
METR 3.06	<p>NEW: Regulator Sizing - 10 PSIG Delivery Pressure</p> <p>1.B: Contact Gas Engineering or Gas Operations and Services for selection and approval of regulators for customer delivery pressure greater than 10 psig, connected loads greater than 10,000 scfh, and inlet pressures greater than 60 psig.</p> <p>2. Table of approved regulators for 10 psig delivery.</p>		January 1, 2013
METR 3.07	<p>Formerly 3.06: Regulator Sizing - Alternate Approved</p> <p>4.: 5 PSIG Delivery Pressure: added the 2" Fisher CS823-IT regulators along with Note (5) that specifies main spring, monitor spring, set point and token relief set point.</p> <p>5.: Added 10 PSIG Delivery Pressure regulators to include the 2" Actaris regulators. Notes were added that specify springs and set points.</p>	April 1, 2012	January 1, 2013
METR 3.08	<p>Formerly 3.07: 175/250 Meter, 7"WC Delivery, 1-60 PSIG Inlet</p>	April 1, 2012	January 1, 2013
METR 3.09	<p>Formerly 3.08: 175/250 Meter, 2 PSIG Delivery, 1-60 PSIG Inlet</p>	April 1, 2012	January 1, 2013

METR 3.10	Formerly 3.09: 175/250 Meter, 7"WC Delivery, 61-100 PSIG Inlet	April 1, 2012	January 1, 2013
METR 3.11	Formerly 3.10: 175/250 Meter, 2 PSIG Delivery, 61-100 PSIG Inlet	April 1, 2012	January 1, 2013
METR 3.12	Formerly 3.11: 425 Meter, 7"WC Delivery, 1-60 PSIG Inlet	April 1, 2012	January 1, 2013
METR 3.13	Formerly 3.12: 425 Meter, Bypass, 7"WC Delivery, 1-60 PSIG Inlet	April 1, 2012	January 1, 2013
METR 3.14	Formerly 3.13: 630 Meter, 7"WC, 1-60 PSIG Inlet	April 1, 2012	January 1, 2013
METR 3.15	Formerly 3.14: 630 Meter, Bypass, 7"WC, 1-60 PSIG Inlet	April 1, 2012	January 1, 2013
METR 3.16	Formerly 3.15: Multiple Meter Installation	April 1, 2010	January 1, 2013
METR 3.17	Formerly 3.16: 15C Compact Meter, 7"WC Delivery Pressure	April 1, 2012	January 1, 2013
METR 3.18	Formerly 3.17: 15C Compact Meter, 2 PSIG Delivery Pressure	April 1, 2012	January 1, 2013
METR 3.19	Formerly 3.18: 15C/3M Meter, 7"WC Delivery Pressure	April 1, 2012	January 1, 2013
METR 3.20	Formerly 3.19: 15C/3M Meter, 2 PSIG Delivery Pressure	April 1, 2012	January 1, 2013
METR 3.21	Formerly 3.20: 15C/3M Meter, 5 PSIG Delivery Pressure	April 1, 2012	January 1, 2013
METR 3.22	Formerly 3.21: 5M/7M Meter, 7"WC Delivery Pressure	April 1, 2012	January 1, 2013

UNCONTROLLED IF PRINTED

METR 3.23	Formerly 3.22: 5M/7M Meter, 2 PSIG Delivery Pressure	April 1, 2012	January 1, 2013
METR 3.24	Formerly 3.23: 5M/7M Meter, 5 PSIG Delivery Pressure	April 1, 2012	January 1, 2013
METR 4	Forms: Updated Form 03 - Gas Meter Data Sheet (Rev 7/12) References: Updated Reference 05 - Fisher CS800 Series Instruction Manual January 2012 Added Reference 06 - Fisher CS400 Series Instruction Manual March 2012	April 1, 2012	January 1, 2013
ODOR 0	Forms and Reference Materials: Added Form 02 - Ameren Shipping Paper - Odorant Updated Reference Materials Reference 07 - ZECK Z9000 User's Manual Rev 0 04/2012 Added Reference 10 - ZECK Z9000 Installation and Maintenance Manual Rev 0 04/2012	January 1, 2011	January 1, 2013
ODOR 1	2. A.: Minor word change: "is normally injected into" replaced "shall be added to" 2. B.: Minor item: "0.65" replaced ".65"	October 1, 2011	January 1, 2013
ODOR 2.02	Odorization Operation 2. A.: Revised to "Odorizer equipment is typically installed at the point of supplier and point of withdrawal from a storage field." versus Odorizer equipment shall be installed. 3. A.(3): In odorization equipment list removed "Fisher" from "Dosador" odorization system 3. F.: Added to sealing for threaded joints "Caution should be taken to avoid sealing compound or Teflon tape from entering the odorant stream. This will prevent wicking effect that can cause a vapor odor to occur." 4. A.(1); Revised: Gas Control will contact Gas Technical Services Supervisor or dispatch a gas technician if there is a deviation from normal that needs investigated. They will not contact area Gas Supervisor or Gas Dispatch. 4. E.: New item: "Gas Operations and Services -Technical Services Supervisor or Engineer should conduct	October 1, 2011	January 1, 2013

UNCONTROLLED IF PRINTED

an annual review of odorant injection rates on small systems where thermal expansion shows increase in volume in the summer months. This review should calculate the odorant concentration by measuring the odorant utilized and dividing by the corrected volume of gas during the period."

5. Liquid Odorant Tank to Tank Transfer is totally new section. This section provides detailed procedures when filling odorizer tank.

6. C.: Revised that if there is a large odorant spill the Gas Technical Services Supervisor and Division operations should be notified as soon as possible.

6. D.: Simplified wording to "Notify Gas Dispatch and Gas Control" when there is a large odorant spill.

6. E.: Added "Liquid odorant" to clarify type of leak.

6. F.: Added Ameren Environmental Services is the group to coordinate disposal of odorant container/ tank.

6. G.: Minor word change, "SCADA" replaced "monitoring data"

ODOR
2.03

Odorant Intensity Testing

July 1, 2012

January 1,
2013

3. H.: Added a clarification "A lower percentage indicates stronger odorant intensity in the gas." for detectable levels from 0.1% up to 0.8% gas in air.

3. I.: Added "Corrective action shall be documented in GCS." when intensity readings are outside the acceptable range.

3. K.: Replaced "him/her" with "customer"

4.: Modified section heading to "Employee Threshold Testing"

4. A. & B.: Deleted these two items that referred to annual perception testing.

5. C.(2): Clarified by adding "for each odorized system" for pre-determined specific test point locations.

8.: Modified section heading to "Record"

8. A. thru C.: Deleted these items since they referred to monthly review by supervisor. As intensity readings are recorded in GCS, those reading out of range will be flagged. This section now states "Records shall be retained in the Gas Compliance System for three (3) years.

ODOR 2.05	Odorant Intensity Testing Flowchart 2.: Replaced with simplified version of flowchart.	January 1, 2011	January 1, 2013
ODOR 4	Forms: Added Form 02 - Ameren Shipping Paper - Odorant Reference Materials: Updated Reference 07 - ZECK Z9000 User's Manual Rev 0 04/2012. Added Reference 10 - ZECK Z9000 Installation and Maintenance Manual Rev 0 04/2012	January 1, 2011	January 1, 2013
OQAL 1	Requirements 16. Covered Task List Added A003 Emergency Response as a covered task	January 1, 2012	January 1, 2013
POLY 0	Added 3 new Reference Materials Reference 16 - McElroy TP 300 Series Test Cap Reference 17 - McElroy Line Tamer Manual for PE 3 thru 6 Inch Reference 18 - Condux Break Away D.Drill Swivels Manual Reference 19 - Central Electrofusion Installation Procedural Manual	July 1, 2012	January 1, 2013
POLY 1	8. B.(3): New item under Weak Link: Install a mechanical weak link. Provides information on a commercial break away swivel for installing PE pipe. Information is for a Condux brand of swivel that includes ordering information. Mechanical break away swivels are weak links that can be used when pulling in PE pipe by such methods as insertion, boring, or plowing.	October 1, 2011	January 1, 2013
POLY 4	Added 3 new Reference Materials Reference 16 - McElroy TP 300 Series Test Cap Reference 17 - McElroy Line Tamer Manual for PE 3 thru 6 Inch Reference 18 - Condux Break Away D.Drill Swivels Manual Reference 19 - Central Electrofusion Installation Procedural Manual	July 1, 2012	January 1, 2013

PRES 0	<p>Added new section PRES 2.05 ERX Alarm Setting Change Request</p> <p>PRES 4 added new Form 03 - ERX Alarm Set Point Change Request</p>	January 1, 2011	January 1, 2013
PRES 1	<p>Requirements</p> <p>2. A.: Added the word "distribution" to specify it is distribution systems being supplied by two regulator stations that require a pressure monitoring device.</p> <p>2. B.: Revised the wording for distribution systems supplied by a single regulator station. "For distribution systems supplied by a single regulator station, if the customer count, based on the most recent Gas Study, is in the range of 950 to 1100 customers, plans should be made to install a pressure recording device."</p> <p>2. E.: Deleted "Mercury"</p>	October 1, 2011	January 1, 2013
PRES 2.01	<p>Mechanical Chart Recorders</p> <p>2. C.(4): Replaced "System Pressure" with "Normal Operating Pressure" for information to be entered on the chart.</p> <p>2. D.: Revised wording of sentence to "The gas field personnel shall review the chart for any high, low, or erratic pressures other than the normal operating pressure for that station or system." Normal operating pressure replaced "pressures other than those defined for that station or system."</p> <p>3. B.: When reviewing recording charts, any indication of abnormally high, low, or erratic pressures must be immediately investigated. Added the word "immediately".</p> <p>4. A.: Added Pressure recorders should be checked annually for accuracy.</p>	January 1, 2011	January 1, 2013
PRES 2.02	<p>Electronic Recorders</p> <p>1.: Removed the name "Mercury" as the brand of ERX throughout PRES 2.02.</p> <p>1.: Added a statement that these procedures apply to transmission and distribution systems and not to the Gas Storage Fields.</p> <p>2. B.: Wording change, Gas Operations and Services - Technical Services personnel replaces Gas Operations and Services - Technical Services Supervisor. Gas Control contacts the GTS Technician directly when there is an alarm.</p>	October 1, 2011	January 1, 2013

2. C.: Wording change, Gas Operations and Services - Technical Services personnel replaces Gas Operations and Services - Technical Services Supervisor. The GTS Technician investigates the situation and corrects any deficiencies.

2. E.: Revised to indicate that Gas Control sends out weekly ERX reports to Gas Operations and Services - Gas Technical Services Supervisors rather than Gas Supervisors. 2. F.: New item: The weekly ERX Report will include a list of ERXs that are not communicating with the host computer. Gas Operations and Services - Gas Technical Services Supervisor will dispatch Gas Technical Services personnel to the location to determine why the unit had lost communication and if possible remedy the situation. If the situation cannot be corrected at that time, the Technical Services personnel will collect and review weekly data until the unit resumes communicating with the host.

4. A.: Under Records added Gas Operations and Services - Gas Technical Services Supervisor receives weekly ERX report from Gas Control.

PRES 2.05	<p>New: ERX Alarm Change Request</p> <p>This section provides the procedures that must be followed in order to authorize Gas Control to change any ERX alarm settings. No alarm setting, temporary or permanent, will be changed without written request and approval by Gas Technical Services Supervisor or Gas Operation and Services - Engineer. The request form should be completed and transmitted electronically.</p> <p>This section lists situation when a request form must be submitted. It also provides a list of activities that do not require a request form.</p>		January 1, 2013
PRES 4	Added Form 03 - ERX Alarm Change Request Form	January 1, 2011	January 1, 2013
PTST 0	Inserted new item PTST 1 3. Test Recording Methods	July 1, 2012	January 1, 2013
PTST 1	<p>Requirements</p> <p>1. F.: Insert new item: "Test pressures higher than normal operating pressures shall not be applied against a closed valve. Valve shall be separated from pipe segment being tested if required test pressure is above normal operating pressure.</p>	July 1, 2012	January 1, 2013

1. G.: Inserted new item: "Do not pressure test with air against a service tee, high volume tee, punch tee, valve tee, or 3-way tee that has been tapped on a pipe pressurized with natural gas.
3. Test Recording Methods - New item that specifies the acceptable method for recording pressure tests.
 - A. Pressure recording charts should be used on any leak and/or strength test, which verifies the facilities MAOP, with test duration of eight (8) hours or longer.
 - B. Pressure chart recorders shall be calibrated annually not to exceed fifteen (15) months.
 - C. Calibration of Ameren owned recorders shall be maintained in Gas Compliance System.
 - D. Contractors shall provide a copy of pressure chart recorder calibration for any project utilizing the recorder.
 - E. Calibrated Test gauges can be used on leak and/or strength test, which verifies the facilities MAOP, with test duration less than eight (8) hours. See METR 2.22
 - F. Process gauges can be used when performing strictly a leak test. Gauge should be in good condition and the needle should be zeroed prior to the subjecting the gauge to pressure
4. A.: Identified service lines two inch and larger would be tested in the same manner as main.
4. B.: Identified service lines two inch and larger would be tested in the same manner as main.
4. C.: Identified service lines two inch and larger would be tested in the same manner as main.
5. E.: Specified maximum allowable test pressure for PE pipe: PE2406/2708 has a maximum test pressure of 120 psig and PE3408/4710 has a maximum test pressure of 200 psig.
7. A.: Revised: For components attached to existing pipeline with a MAOP of 100 psig or less the minimum test pressure duration is 10 minutes.
7. B.: Revised: For components installed on system with MAOP over 100 psig the minimum pressure test duration is 10 minutes or the duration specified by Engineering based on the MAOP of the system.
9. B.: Under Test Records, the pressure recording chart will be the official record and shall be retained in the final as constructed job packet.

PTST
2.01

Leak Test

January 1,
2011

January 1,
2013

3. B.: Revised the wording: "For mains and 2 inch and larger service lines, the leak test duration shall be 5 minutes per 100 feet of pipe length per inch of nominal pipe diameter with minimum test duration as listed below for the specific pipe diameter. Test duration begins after the test pressure has stabilized." 3. C.: Insert new item to clarify the 20 hour test duration: "For pressure tests with a minimum required time longer than twenty (20) hours, consult with Gas Operations and Services - Engineering to review the proposed test based on the pipe material and size, test pressure, and the ability to break the test into smaller segments."

3. D. Table Note 2.: Clarified use of duration formula: "The following formula can be used to determine the minimum test duration for the specific pipe diameters and "L" being rounded up to the next 100 foot increment as noted above."

4.B.(3): Inserted new item under Leak Test Procedures: "If water is used follow the procedures in PTST 2.03 - Hydrostatic Pressure Testing."

4. C.: Added "and stabilized" to reinforce the test duration does not begin until the test pressure has stabilized.

4. E.: New item when pressure testing is being recorded on a chart: "If pressure test is being recorded by a chart recorder, the inspector or person responsible for the test should document, on the chart, the reason for any pressure fluctuation, such as temperature, vibration, vandalism, leak, etc, once the test duration has begun. Documentation can be attached to the chart if needed"

4. F.: Added "water" to the test medium that would have to bleed off after a leak test.

5. Leak Test Records

5. B.: Revised to "Test records shall include at a minimum the following information:"

5. B.(1) Expanded the "Description of facilities being tested" by providing a list of information that should be recorded. Description of facilities should include: Pipe size and type, length of test segment, beginning and ending location of test segment, measurements, stationing, GPS coordinates, facility identification, or other methods that will describe the location.

5. B.(3): Corrected: should be test company not test Ameren Illinois.

UNCONTROLLED IF PRINTED

5. B.(9)(a): Added "calibration date" should be recorded on the recording chart.

5. B.(9)(b): Added "Owner of pressure recording chart" is to be recorded on the chart..

5. B.(9)(c): Revised pressure recording chart is now required for required test durations of 8 hours or longer.

5. B.(9)(d): Added: "Pressure recording chart should be installed and recording at some point during the pressurization to ensure it is recording the correct pressure. A test gauge, METR 2.22, may be used to verify accuracy of the recording chart if there is question."

5. B.(9)(e): Added: "If the test segment is going to be blown down following the test record at least the initial start of the blow down to verify operation of the recorder. Document on the chart, if the test segment is not being blown down at the completion of the test"

5. B.(9)(f): Added: "Document the cause of any pressure fluctuation on the recording chart once the pressure has initially stabilized such as, temperature change, vibration due to outside forces, vandalism, leak and etc."

5. B.(9)(g): Added: "Pressure fluctuation due to temperature change that occurs during test duration should be documented with calculation verifying the fluctuation is not due to a leak. Adjust the absolute pressure at the end of the test with a multiplying factor:" A formula for calculating temperature factor is included in this section.

5. B.(9)(h): Added: Document the beginning and end of test period(s). If recording chart is recording both a leak and a strength test that have different test pressures and duration, the beginning and end of each test should be documented.

5. C.: Added: If test gauge is used to record leak test, record the test gauge ID or serial number on the test record.

5. D.: Added: Test records shall be retained in the final as constructed job packet.

PTST
2.02

Strength Test

1. A.: Revised wording: "When a separate strength test is required, it shall be performed after the leak test is successfully completed." 1. B.: Added: When strength testing a valve, valve should be in open position. If valve is left in the closed position, the test pressure should not exceed 1.1 times the valve's pressure rating.

January 1,
2011

January 1,
2013

2. A.: Added reference to PTST 2.03 - Hydrostatic Testing when water is used as test medium.
3. B.: Added reference to PTST 2.03 - Hydrostatic Testing since water is used as test medium.
4. Strength Test Records: added the same language from PTST 2.01 5. that specified what information should be recorded on pressure recording chart.
4. B.: Revised to "Test records shall include at a minimum the following information:"
4. B.(1) Expanded the "Description of facilities being tested" by providing a list of information that should be recorded. Description of facilities should include: Pipe size and type, length of test segment, beginning and ending location of test segment, measurements, stationing, GPS coordinates, facility identification, or other methods that will describe the location.
4. B.(3): Corrected: should be test company not test Ameren Illinois.
4. B.(9)(a): Added "calibration date" should be recorded on the recording chart.
4. B.(9)(b): Added "Owner of pressure recording chart" is to be recorded on the chart..
4. B.(9)(c): Revised pressure recording chart is now required for required test durations of 8 hours or longer. 4. B.(9)(d): Added: "Pressure recording chart should be installed and recording at some point during the pressurization to ensure it is recording the correct pressure. A test gauge, METR 2.22, may be used to verify accuracy of the recording chart if there is question."
4. B.(9)(e): Added: "If the test segment is going to be blown down following the test record at least the initial start of the blow down to verify operation of the recorder. Document on the chart, if the test segment is not being blown down at the completion of the test"
4. B.(9)(f): Added: "Document the cause of any pressure fluctuation on the recording chart once the pressure has initially stabilized such as, temperature change, vibration due to outside forces, vandalism, leak and etc."
4. B.(9)(g): Added: "Pressure fluctuation due to temperature change that occurs during test duration should be documented with calculation verifying the fluctuation is not due to a leak. Adjust the absolute pressure at the end of the test with a multiplying factor:" A formula for calculating temperature factor is included in this section.

4. B.(9)(h): Added: Document the beginning and end of test period(s). If recording chart is recording both a leak and a strength test that have different test pressures and duration, the beginning and end of each test should be documented.

4. C.: Added: If test gauge is used to record leak test, record the test gauge ID or serial number on the test record.

4. D.: Added: Test records shall be retained in the final as constructed job packet.

PTST 2.03	Hydrostatic Pressure Testing 2. B.: Added that copy of the Ameren Illinois EPA Water Pollution Control Permit should be part of the final job packet when hydrostatic pressure testing is performed.	July 1, 2012	January 1, 2013
PUBL 2.01	2. E.: Updated to Ameren Illinois Communications rather than Corporate Communications 6. B.: Updated to Ameren Illinois Communications rather than Corporate Communications	January 1, 2011	January 1, 2013
QUAL 0	QUAL 4: Added Form 18 - Inaccurate or Incorrect Record Notification	January 1, 2012	January 1, 2013
QUAL 4	Added Form 18 - Inaccurate or Incorrect Record Notification	January 1, 2012	January 1, 2013
REGS 4	Updated the PDF versions of the regulator station designs with the 10-11-2011 version. Added "The DGN and DWG files are on the Organizational Data Drive at O:\Gas\Reg Station Design Standards. The DGN and DWG files contain the active drawing files. Deleted the DWG drawing from the Forms and Reference Materials section since majority of O&M users cannot access DWG files.	January 1, 2011	January 1, 2013
REPR 1	Requirements 1. B.: Added a sentence "See SAFT 1 for safety related conditions that may require a report to the ICC and PHMSA 1. M.: New: "Prior to welding or cutting activities on any steel pipeline take the proper precautions to eliminate any chance of accidental ignition. See ACIG 2.01"	April 1, 2012	January 1, 2013

4. Steel Pipe Repairs Methods 4. G.(2): Insert new item: An electric bond shall be installed prior to cutting metallic gas piping and maintain until all reconnections are completed or a gas free environment exists. See ACIG 2.01

4. G.(4): Added "See ACIG 2.01 if segment is being installed on a rectified system." ACIG 2.01 states rectifiers should be turned off prior to cutting or separating the pipe

REPR 2.01	<p>Compression Couplings</p> <p>1. D.: Grammatical, added "ed" to install.</p> <p>2. C.(3)(b): Deleted the item that references couplings not encapsulated at time of repair when pull out was not detected.</p> <p>2. C.(3)(c): Is now (3)(b) and has been revised to require a compression coupling that was tightened to repair a leak to be encapsulated or removed within 30 days even if pull out was not detected.</p> <p>3. Service Line Repair Methods for Compression Couplings</p> <p>3. C. (3)(b) Deleted the item that references couplings not encapsulated at time of repair when pull out was not detected.</p> <p>3. C.(3)(c): Is now (3)(b) and has been revised to require a compression coupling that was tightened to repair a leak to be encapsulated or removed within 30 days even if pull out was not detected.</p>	January 1, 2012	January 1, 2013
REPR 3.02	<p>Dresser Reinforcing Sleeves</p> <p>Added notes below tables for Style 110, 220, and 220S: Pressure ratings listed in the tables are based on Class 3 design factor of 0.50. Pressure ratings can be adjusted for Class 1, Class 2, or Class 4 locations. Design factor for Class 1 is 0.72, for Class 2 is 0.60 and Class 4 is 0.40. Contact Engineering before adjusting pressure ratings.</p>	October 1, 2011	January 1, 2013
SECR 0	<p>Security Plan has been significantly revised by Ameren Security due in part to a change in threat level classification. There are now two Threat Levels that replace the original 5 Color Coded Levels.</p> <p>The Security Plan should be reviewed in depth with all gas personnel.</p> <p>SECR 2.02 Title changed to Critical Gas Facility Security Measures</p>	January 1, 2011	January 1, 2013

SECR 1	<p>2. A.: Definition of Critical Gas Facility has been significantly expanded.</p> <p>2. B.: New term: Baseline Security Measures - measures taken at all facilities during normal operating conditions</p> <p>2. C.: New term; Enhanced Security Measures - measures taken at critical facilities during normal operating conditions</p> <p>2. D.: New term: Elevated Threat Alert - warns of a credible terrorist threat against the United States and its territories that is general in both timing and target, or details significant trends and developments in terrorism such that it is reasonable to recommend implementation of protective measures to thwart or mitigate against an attack.</p> <p>2. E.: New term: Imminent Threat Alert - warns of a credible, specific, and impending terrorist threat or on-going attack against the United States and its territories that is sufficiently specific and credible to recommend implementation of protective measures to thwart or mitigate against an attack.</p> <p>2. I.: Revised Ameren Critical Gas Facilities with criteria listed in the revised Transportation Security Administration Office of Pipeline Safety Security Guidelines issued April 2011.</p>	January 1, 2011	January 1, 2013
SECR 2.01	<p>Communicating Security Threats</p> <p>4.: Call Tree - updated the contacts - Change Regional VP to VP Operations & Tech Services and deleted the VP Gas Supply & System Control</p> <p>Updated phone number for the VP Operations & Tech Services</p> <p>Delete the Mattoon and Peoria Dispatch Offices</p>	January 1, 2011	January 1, 2013
SECR 2.02	<p>Critical Gas Facility Security Measures</p> <p>This section has been totally rewritten and should be reviewed in depth with all gas personnel.</p>	January 1, 2011	January 1, 2013
SERV 1	<p>Requirements</p> <p>2. Depth</p> <p>2. A.: On the depth of service line an new item has been added: "Additionally, service tee should have minimum of twenty four (24) inches cover. When the required minimum cover for the service tee cannot be provided, Safety Barrier Tape, (Stock Code 19 06 958), shall be installed approximately twelve (12)</p>	April 1, 2012	January 1, 2013

inches below the surface to provide advance warning to excavators."

2. C.: Inserted new item that address where minimum cover cannot be provide: "Where the required minimum cover for the service line cannot be provided, Safety Barrier Tape shall be installed approximately six (6) inches below the surface to provide advance warning to excavators. Additionally, location of where service line buried depth is less than eighteen (18) inches should be recorded on the Gas Service Transaction Sheet/Card. Method of protection should also be recorded on the Gas Service Transaction Sheet/ Card."

2. F.: New item added that addresses plowing or boring of service lines: "Prior to plowing or boring in a service line, the proposed service line route should be inspected for public and privately owned buried facilities, especially sewer laterals that may conflict with the gas service line. Buried facilities that cross or are within eighteen (18) inches of the proposed plow path should be exposed or verified not to be in conflict with plow path and plow depth."

5. Location:

5. A.: Revised to specify "New residential" service lines should installed on the most direct route from the main to the proposed meter location. 5. B.: Revised location requirement to that addresses where preferred service riser location does not meet clearance requirements. "All new residential gas meters shall be located immediately adjacent to an outside wall at a location readily accessible by meter readers and emergency responders. The preferred location of the meter riser is within 2 to 5 feet of the front corner of the structure as long as the clearance requirements list below can be achieved. Alternate location would be the next closest point that meets clearance requirements. The gas meter can be installed on the front side of the home if agreed upon by Ameren Illinois and the property owner."

5. C.: Inserted new item that address when clearance requirements should be met when relocating or replacing an existing service line. A table is provided that lists activity and clearance requirements.

5. D.: Grammatical change which just rearranged the words of issues that should be taken into consideration when locating a commercial meter location.

9. Pressure Testing 9. C.: Replaced "shall" with "should": "Service line being pressure tested should be disconnected from the meter set or customer pip-

ing while the line is under test and until the test pressure has been released."

SERV 2.02	<p>Excess Flow Valves</p> <p>3. EFV Sizing</p> <p>3. B.: Revised to clarify the service line shall not be reduced in size downstream of the EFV. 3. D.: Inserted new item on how to select an EFV: "When selecting an EFV, the maximum capacity of the meter being specified should be used for the maximum flow. Select the EFV that has the maximum design flow that is closest to the selected meter and has a service length that is shorter than the maximum length that corresponds with the maximum design flow. The maximum meter capacity should not exceed the listed maximum design flow."</p> <p>3. D.(1): Revised table for 1/2" PE Service line EFV's by combining both Perfection Series 400 and UMAC Series 350 into a single table. Both manufacturers have the same stock code so either one could be supplied. A designer would not know which one was being issued.</p> <p>3. D.(2): Revised table for 1" PE Service line EFV's by combining both Perfection and UMAC EFV's into single table for comparable series.</p> <p>3. E.: Revised table for the 3/4" steel EFV by combining Perfection and UMAC into single table for comparable series.</p>	January 1, 2012	January 1, 2013
SERV 2.03	<p>Farm Tap Installation</p> <p>6. B.: Added: "Install a 5 lb anode on the tracer wire at the farm tap outlet. Do not bond the tracer wire to the farm tap piping."</p> <p>7.: Farm Tap Capacity Tables</p> <p>7. B.: Single Cut Farm Tap Capacity Table: Expanded table to include the three stock coded 3/4" steel EFV's</p> <p>7. B. Notes: Revised Notes 2. And 3. to include "Max flow" for the 1/2" and 1" outlet EFV's.</p> <p>7. C.: Double Cut Farm Tap Capacity Table: Expanded table to include the three stock coded 3/4" steel EFV's.</p>	April 1, 2012	January 1, 2013
SERV 3.06	<p>Single Cut Farm Tap, 60 to 450 psig Inlet Pressure</p> <p>Updated Material List:</p> <p>Item 2: Added series 700/800 EFV in description</p>	October 1, 2011	January 1, 2013

Item 6: Added Pete's Plug in description

Item 12: Added 1" Union for 1" outlet

Item 14: Added specifications for risers

Item 18: Added Tracer wire to table

Revised Note below table: "Item 1: 6" and larger transmission and high pressure distribution mains or 2" and smaller Schedule 80 pipe requires the use of either the Mueller H-17656 Valve Tee or Mueller H-17800 Curb Valve Tee if the wall thickness of the pipe is unknown or cannot be verified. See TAPS 2.05 for maximum wall thickness for AutoPerf Service Tees."

SERV 3.07	Double Cut Farm Tap, 451 to 740 psig Inlet Pressure Updated Material List: Item 2: Added 700/800 EFV in description Item 9: Added Pete's Plug in description Item 10: New: 3000 psig rated tee replacing malleable street tee Item 17: Added 1" Union for 1" outlet Item 19: Added specifications for risers Item 20: Added Series 350/400 and Series 700/800 to EFV description Item 25: Added Tracer wire to table Revised Note below table: "Item 1: 6" and larger transmission and high pressure distribution mains or 2" and smaller Schedule 80 pipe requires the use of either the Mueller H-17656 Valve Tee or Mueller H-17800 Curb Valve Tee if the wall thickness of the pipe is unknown or cannot be verified. See TAPS 2.05 for maximum wall thickness for AutoPerf Service Tees."	October 1, 2011	January 1, 2013
--------------	---	--------------------	--------------------

SERV 3.08	Double Cut Farm Tap, 741 to 1000 psig Inlet Pressure Updated Material List: Item 2: Added 700/800 EFV in description Item 9: Added Pete's Plug in description Item 10: New: 3000 psig rated tee replacing malleable street tee Item 17: Added 1" Union for 1" outlet Item 19: Added specifications for risers	October 1, 2011	January 1, 2013
--------------	---	--------------------	--------------------

Item 20: Added Series 350/400 and Series 700/800 to EFV description

Item 24: Added Tracer wire to table

Revised Note below table: "Item 1: 6" and larger transmission and high pressure distribution mains or 2" and smaller Schedule 80 pipe requires the use of either the Mueller H-17656 Valve Tee or Mueller H-17800 Curb Valve Tee if the wall thickness of the pipe is unknown or cannot be verified. See TAPS 2.05 for maximum wall thickness for AutoPerf Service Tees."

STLP 0	Added: STLP 1 12: Pipe Thread Sealers	January 1, 2012	Janu- ary 1,2013
STLP 1	<p>Requirements</p> <p>3. Joining: 3. B.: New item: "Threading is acceptable for joining steel pipe that is used for above ground assemblies such as, but not limited to, meter sets, pressure control stations, odorization stations, compressor stations, etc."</p> <p>3. C.: New item: Threaded caps are approved for use in abandoning gas facilities. See ABND 2.01</p> <p>12: Pipe Thread Sealers (New Item)</p> <p>12. A.: All threaded connections should be made using an approved pipe thread sealers or Teflon thread tape</p> <p>12. B.: The following criteria must be met for a pipe thread sealer to be approved. (1) Minimum pressure of 1000 psig</p> <p>(2) Immediate cure time, can be pressurized immediately after assembly</p> <p>(3) Brushable to temperatures of zero (0) degrees Fahrenheit or lower</p> <p>(4) Minimum two (2) years shelf life</p> <p>(5) Health Hazards Rating of one (1) or less</p> <p>(6) Flammability Rating of two (2) or less</p> <p>(7) Reactivity Rating of zero (0)</p> <p>12. C.: Approved Pipe Thread Sealers - Table listing the approved stock coded thread sealers. There is also a table with the Hazardous Materials Identification System coding of the thread sealers explained.</p>	April 1, 2012	Janu- ary 1, 2013

STLP 2.01	Design Pressure 5.: Steel Pipe Stock Code Table: Added a column listing the Pipe Schedule for each stock coded pipe.	January 1, 2012	January 1, 2013
TAPS 0	TAPS 4: Added two items to Reference Materials	October 1, 2011	January 1, 2013
TAPS 1	Requirements 1. G.: Revised requirements for Tapping Request Form to include all sizes of transmission and high pressure distribution pipeline, and distribution pipelines 6" and large. A Tapping Request Form is required when any tapping equipment, regardless of size of fitting, and personnel are being requested from another operating center. 1. I.: Inserted new: "Tapping and stopping equipment should be in good operating condition prior to beginning tapping and stopping operations. Prior to beginning a tapping and/or stopping operation a dry run should be made." 1. J.: Inserted new: "Tapping and stopping equipment that malfunctions should be tagged out-of-service and repaired before being used again." 2.: Equipment Selection: 2. B.: Revised the Max Working Pressure for Stopping operations with a Mueller Unit No. 3SW to 275 psig. Previous was 230 psig. 3.: Planning Requirements 3. C.: Added a clarification on the tapping and stopping machine rating. The machine is to be rated for at least the actual operating pressure at the time of the tapping and stopping operations. The stopper fittings shall be rated for the MAOP. 3. F.: Added new: Gas Engineer or Gas Operations & Services - Engineer is to provide the purging plan(s) that is to be included in the job packet. See PURG 2.01 4. Pre-Job Conference 4. D.(6): Inserted new: Re-pressurization and purge plan 4. D.(8): Expanded Responsibilities of involved personnel to include operator qualifications and span of control. 4. D.(10): Added new: "Location and accessibility of isolation valve(s) that will be or could be used and method of tagging valve as out of service."	October 1, 2011	January 1, 2013

4. D.(11): Added new: "Method of communication between qualified field personnel monitoring pressures and tapping/stopping operations."

5.: Identification of Pipe Before Tapping

5. D.: Added "wall thickness" to the list of pipe properties to review before tapping.

5. E.: Revised to: "To ensure the exposed pipe is the one to be tapped, gas field personnel should consider extending the excavation or installing a small tap on the pipe to verify content and/or pressure."

6.: Fitting Placement

6. B.: Added "longitudinal seam" along with circumferential seam that should not be tapped through.

6. D.: Added reference to WELD 2.04 - Maintenance welding procedures.

8.: Tapping/Stopping/Completion

8. G.: Grammatical revision: "If Gas Control was monitoring, contact them upon completion of tapping/stopping operations and verify their monitoring parameters have returned to normal operation."

TAPS 2.05	<p>Mueller Autoperf Tee</p> <p>2.: Installation Instructions</p> <p>2. B.: Added: "soap" to the sentence "Do not quench with water or soap."</p> <p>2. G.: Corrected spelling of "perforation"</p> <p>3.: Maximum Pipe Wall Thickness:</p> <p>Revised Note below table that allows use of the Autoperf tee on any size pipe if the wall thickness is known or can be verified to be less than 0.281 inches.</p>	October 1, 2011	January 1, 2013
TAPS 4	<p>Added two references</p> <p>Reference 19 - Mueller H-17045 Steel Service Tee Stopping Instructions</p> <p>Reference 20 - TDW Hot Tapping and Stopple Pipe Plugging</p>	January 1, 2011	January 1, 2013
TURN 0	<p>TURN 2.02 5. Changed to Initiating Service</p> <p>New TURN 4 Updated Warning Tag</p>	January 1, 2011	January 1, 2013
TURN 2.02	<p>Large Commercial - Industrial Customer</p> <p>5.: Initiating Service 5. C.: Revised to: "Check existing regulator pressure set point and adjust if necessary."</p>	January 1, 2011	January 1, 2013

UNCONTROLLED IF PRINTED

(1) If customer's gas equipment is not in operation, use blow-down facility to create flow.

(2) Use test gauge to set and check pressure. See METR 2.22.

(3) A lock-up test should be performed on all new meter set installations and on existing meter sets where a new regulator has been installed."

6.: Records 6. A.: Revised wording to: "Gas field personnel shall complete Gas Meter Data Sheet for all meters that are to meter at an elevated pressure (> 7" w.c./0.25 psig). See METR 2.16 for instruction.

6. B.: Revised wording to: "Completed Gas Meter Data Sheet shall be submitted to Gas Supervisor for review and distribution. See METR 2.16 for distribution list."

TURN 2.11	<p>Warning Tag</p> <p>2.: Inspecting Customer Piping and Appliances</p> <p>2. B.: Added reference to TURN 4 for copying of Warning Tag</p> <p>2. C.: Added reference to TURN 4 for copying of Warning Tag</p> <p>5.: Code Violations</p> <p>5. B.: Added reference to TURN 4 for copying of Warning Tag</p> <p>6.: Hazardous Conditions</p> <p>6. B.: Added reference to TURN 4 for copying of Warning Tag</p> <p>7.: Customer Mailing</p> <p>7. A.: Added reference to TURN 4 for copying of Warning Tag</p> <p>8.: Records</p> <p>8. A.: Added reference to TURN 4 for copying of Warning Tag</p>	October 1, 2011	Janu- ary 1, 2013
TURN 4	New with copy of Form 01 - Warning Tag Stock Code 16 01 263		Janu- ary 1, 2013
VALV 2.01	<p>Valve Installation</p> <p>3. Emergency Line Valves</p> <p>3. A.(1): Inserted "sectionalizing block" to clarified that transmission line must have a sectionalizing block</p>	April 1, 2012	Janu- ary 1, 2013

valve spaced as follows: This makes language consistent with VALV 1.

3. A.(2): Replaced "emergency" with "sectionalizing block" valve to identify where blow down valves are to be installed.

Clarified that any non-maintenance work intended to either increase or decrease regulator station capacity is considered a Station Rebuild and must meet emergency valve requirements. Made following changes:

4. C.(1): Added "or decrease" for non-maintenance work.

4. C.(3)(c): Added "or decrease" when changing regulators

4. C.(3)(i): Added "or decrease" for changing springs, orifices, liners, or ports.

5. Non-Emergency Valves 5. F.: Added new item: If a non-emergency valve is used to control gas during an emergency situation, the valve will be designated as an Emergency Valve after the emergency situation has been resolved. An Emergency Valve ID shall be designated. The valve shall be entered into the Gas Compliance System and on the electronic gas system map.

WELD 0	<p>WELD 4 Revisions to:</p> <p>Reference 09 - ENE - Ameren-F03 Rev 4</p> <p>Reference 10 - ENE - Ameren-F04 Rev 3</p> <p>Reference 14 - ENE - Ameren F08 Rev 3</p> <p>Reference 23 - ENE - Ameren WF03 Rev 3</p> <p>Reference 24 - ENE - Ameren WF04 Rev 3</p> <p>Reference 36 - ENE - Ameren F04R Rev 2</p>	April 1, 2012	January 1, 2013
WELD 1	<p>Requirements</p> <p>7. G.: Revision on storage of radiographic film: ". If the Company requests the actual radiographic film be retained, the film shall be processed, handled and stored in a manner such that the images can be interpreted for at least three (3) years." Added the statement "If Company request the actual radiographic file be retained" to clarify not all radiographic film had to be stored.</p>	July 1, 2012	January 1, 2013
WELD 2.04	<p>Maintenance Welding</p> <p>6. Welding Procedures</p>	April 1, 2012	January 1, 2013

UNCONTROLLED IF PRINTED

6. B.(5): Deleted the procedure on moving the transducer across pipe in an overlapping "Z" pattern.

WELD
4

Revisions made to the following:

April 1, 2012

January 1,
2013

Reference 09 - ENE - Ameren-F03 Rev 4 - SMAW process corrected the Wall Thickness Group applies to branch and sleeve pipes with wall thickness less than 0.188"

Reference 10 - ENE - Ameren-F04 Rev 3 - SMAW process corrected the Wall Thickness Group applies to branch and sleeve pipes with wall thickness less than 0.188"

Reference 14 - ENE - Ameren-F08 Rev 3 - SMAW process corrected the Wall Thickness Group applies to branch and sleeve pipes with wall thickness less than 0.188"

Reference 23 - ENE - Ameren-WF03 Rev 3 - GMAW process corrected the Wall Thickness Group to branch and sleeve pipes with wall thickness less than 0.188"

Reference 24 - ENE - Ameren-WF04 Rev 3 - GMAW process corrected the Wall Thickness Group to branch and sleeve pipes with wall thickness less than 0.188"

Reference 36 - ENE - Ameren-F04R Rev 2 - SMAW process corrected the Wall Thickness Group applies to branch and sleeve pipes with wall thickness less than 0.188"

Supersedes: July 1, 2012

CHANGE SUMMARY

July 1, 2012

Change Summary July 1, 2012

Document	Change Summary	Previous Document Dated	Current Document Dated
BORE 2.03	<p>2. J. & K.: Corrected "allowable tensile load" from "allowable load tension" to correspond with terminology used in Poly pipe reference documents.</p> <p>2. Table: Change table heading to ALLOWABLE TENSILE LOAD"</p> <p>2. Note below table made the same change "Allowable Tensile Load".</p>	April 1, 2012	July 1, 2012
CORR 0	CORR 2.03: Deleted "6. Trent #2A	April 1, 2012	July 1, 2012
CORR 2.03	6.: Deleted Trent #2A Wax Tape since this is the same product that is in CORR 2.13 Trenton #2A Wax Tape.	April 1, 2012	July 1, 2012
CORR 2.13	<p>2. B.: Reformatted the section on Application of Trenton #2A Wax Tape.</p> <p>2. B. (1): A thin coat of Temcoat Primer can be applied to wet or cold surfaces.</p> <p>2. B. (3): Revised language in Apply Primer. The Temcoat Primer needs to be rubbed and pressed firmly to displace moisture and ensure adhesion.</p> <p>2. C.: Reformatted section on Apply Tape:</p> <p>2. C. (5): Added "mesh outer wrap, Glas-Wrap, can be used to protect the tape during backfilling operations</p> <p>2. D. Reformatted Applying Trenton Fill-Putty (profiling material).</p> <p>2. D.: Minor revision to clarify that a "wire" brush should be used to remove dirt, loose rust or old coating from the surface prior to applying the Trenton Fill-Putty.</p> <p>2. D. (4): Added "mesh outer wrap, Glas-Wrap, can be used to protect the tape during backfilling operations</p>	January 1, 2011	July 1, 2012
CORR 2.29	<p>2. B. (3)(j)&(p): Under Remedial Action for CP repairs, eliminated the reference to AmerenIP in the instruction on completing: (j) IRMA and (p) SIMP screens.</p> <p>3. D. (2): Deleted the "Former IP" section. All areas within Ameren Illinois are now using the same procedure, 3. D. (1), for performing Isolated Section Check for required number of annual readings</p>	April 1, 2012	July 1, 2012

UNCONTROLLED IF PRINTED

EMER 0	Added EMER 2.10 - CNG Trailers	January 1, 2011	July 1, 2012
EMER 2.01	4. D.: Added "leak surveyor (in-house or contracted)" as another group the Call Taker does not have to relay safety instructions to if an individual in this group would call in a gas odor.	January 1, 2011	July 1, 2012
EMER 2.08	2. D.: Revision to situations where it isn't necessary to submit the fitting for failure analysis. 2. D. (3): Revised wording to "Leaks due to loose threaded fittings." 2. D. (4): Added "Aldyl-A and Plexco" descriptor to tapping tee caps and "compression couplings, tees, valves" to fittings with known problems.	April 1, 2012	July 1, 2012
EMER 2.10	New Section added - CNG Trailers. Ameren Illinois has 6 CNG trailers, 4 with 8.1 MCF capacity at 3600 psig and 2 with 6.1 MCF capacity at 3600 psig. Trailers are located in Belleville, Kewanee, Decatur, Peoria, and Springfield. CNG trailers are under the control of Gas Technical Support. Contact information is included.		July 1, 2012
FORW	5.: Update Contacts for Compliance with John Bozarth's name	April 1, 2012	July 1, 2012
<u>INCD 1</u>	6.: Updated Gas Compliance Contact List with John Bozarth's name	January 1, 2012	July 1, 2012
LEAK 2.08	2. G.: Revision to handling bottle/cylinder of hydrogen/nitrogen gas mixture for FI unit. Added if bottle has not been used and has sat in storage for approximately a month or longer bottle should be rolled prior to filling FI unit's cylinder. If the bottles/cylinder is being transported in vehicle the bottle/cylinder does not need to be rolled prior to filling the FI unit's cylinder. 3. H.: Deleted the 1 hour and revised wording to "short duration or intermittent leak survey where use of an FI unit is impractical."	April 1, 2012	July 1, 2012
<u>MAIN 1</u>	3. A. Table: Added heading to table of minimum cover for mains "PHMSA PART 192.327 Minimum Cover Requirements" and deleted asterisks from Distribution Mains and High Pressure Distribution Mains. 9. D.: Updated reference to the appropriate welding section for joining, WELD 2.03 Construction of Pipeline and Pipe Systems	April 1, 2012	July 1, 2012

METR 0	METR 2.10 Small Diaphragm Meter Repair: Totally revised with new topic headings	April 1, 2012	July 1, 2012
METR 2.10	Totally revised the entire Small Diaphragm Meter Repair procedures with Manufacturer specific domestic meter repair procedures: American Class A & B repair, Rockwell Class A & B repair, and Sprague Class B repair.	January 1, 2011	July 1, 2012
METR 2.20	2. A. (9): Corrected the word "or" with "of" 3. A. (8): Corrected the word "or" with "of"	January 1, 2011	July 1, 2012
METR 2.24	5. A. (5): Added a reference to METR 2.20 - Meter Header Inspection when checking for corroded bolts on banded regulators when replacing large volume diaphragm meters	January 1, 2011	July 1, 2012
ODOR 2.03	3. D.: Revised the calibration interval for odorometer to annual not to exceed 12 months from annual not to exceed 15 months. Manufacturer's calibrations are good for 1 year.	January 1, 2012	July 1, 2012
PMRK 0	Inserted Replacement Stickers as PMRK 3.01 2.	October 1, 2011	July 1, 2012
PMRK 3.01	1.: Updated the sticker information on the 3 styles of stocked COTT markers. New sticker has the 800 755 5000 Ameren Illinois phone number. 2.: Added Stock Number for replacement sticker for the COTT pipeline marker.	January 1, 2011	July 1, 2012
POLY 0	Added Reference 15 - Performance Pipe Butt Fusion New Brochure April 2012 to Forms and Reference Materials	October 1, 2011	July 1, 2012
POLY 2.01	2. A. Table: Deleted the 1000 ft coil of 4" PE2406/2798 pipe. Storeroom will stock the 40 ft stick and 600 ft coil pipe. 2. A. Added Note 3 below table of PE 2406/2708 pipe. "PE2406/2708 risers are the same SDR as the pipe." 2. B.: Added Notes below table of PE 3408/4710 pipe. "PE3408/4710 services, 1" CTS and 2" IPS require a SDR 7.0 riser." "Use SDR 7.0 with Design Temperature of 120° F to calculate maximum design pressure for 1" CTS and 2" IPS PE 3408/4710 service line pipe." 3. B.: Added Notes below Design Temperature table. "120°F temperature due to service line riser exposure to sun." "73°F temperature used for buried gas PE pipe with no above ground exposure."	May 1, 2010	July 1, 2012
POLY 2.04	1. C.: New item: "Butt fusion is not allowed when connecting two pipe sections with a wall thickness difference that exceeds one SDR value (SDR 7.0 vs SDR 11.0) or two pipe	October 1, 2011	July 1, 2012

sections of different densities (PE2406/2708 vs PE3408/4710)

POLY 2.06	2. D.: Added Note that the 1" CTS PE3408 Stab coupling is sized for SDR 11.5 pipe and is not compatible with the 1" PE3408/4710 service riser pigtail which is SDR 7.0. Electro-fusion is the only means of connecting the service pipe to the riser pigtail.	October 1, 2011	July 1, 2012
POLY 4	Added Reference 15 - Performance Pipe Butt Fusion New Brochure April 2012	January 1, 2011	July 1, 2012
PTRL 1	2. Table: Deleted "and Critical Area Patrols" from heading of 3rd column in Frequency Table to make consistent with PTRL 2.01. Critical Area Patrols applies only to distribution pipelines.	March 1, 2010	July 1, 2012
PTST 0	Added PTST 2.03 3. Safety	April 1, 2012	July 1, 2012
PTST 1	3. A.: Added "This is a combination leak and strength test." to the testing of mains and service with MAOP of 60 psig or less. 3. B.: Added "This is a combination leak and strength test." to the testing of mains and service with MAOP above 60 psig and below 100 psig. 3. C.(2): Inserted statement "Separate leak and strength tests are required if 1.5 times the design MAOP test pressure equals or exceeds 20% SMYS of the pipe." Inserted to match language in Part 192.507 3. C.(3): Revised wording to clarify "When a leak test is performed separately from a strength test, the leak test shall be at a minimum test pressure of 100 psig for minimum of 1 hour or for the duration specified in PTST 2.01 whichever is longer." 7. B. Table: Correct Weld-End Insulator from Weld-In	April 1, 2012	July 1, 2012
PTST 2.03	Hydrostatic Pressure Testing procedures have been significantly expanded from the January 1, 2011 version. There are too many revisions to list. Expanded the Environment Protection Requirement section and added a Safety section. Prior to performing any hydrostatic testing this entire section should be reviewed with those performing the test.	January 1, 2011	July 1, 2012
PURG 2.01	1. B.: Inserted a new item "Gas Engineering or Gas Operations and Engineering will provide detailed purging plans prior to blow-down or purging operations on transmission or high pressure distribution mains." 3. D.: Inserted a new item "Blow-down valves should be turned to fully open position as quickly as possible to mini-	January 1, 2012	July 1, 2012

mize possible erosive damage to the valve which could occur attempting to pass a high volume of gas through a partially opened valve."

REGS 2.01	<p>1.: Minor word changes only in E., F., and G.</p> <p>2. D.(3): Added vent screens should be in place on vent lines.</p> <p>2. E.: Clarified above grade piping is checked for atmospheric corrosion and risers are to be checked for disbanded coating.</p> <p>2. F. (1)(a)&(b): New: When checking for leakage, this section identifies what piping is considered station piping when: (a) pressure control station is located within a fenced area and (b) pressure control station is not located within a fenced area. Follow procedures in LEAK 2.09 - Walking Survey when checking for leakage.</p> <p>2. F. (2): References LEAK 2.04 and LEAK 2.05 for leak classification and reporting.</p> <p>2. F. (4): Any below grade leak found during an inspection shall be documented on a Gas Leak Field Case Report.</p> <p>2. F. (5): All above grade leaks identified during an inspection can be collectively documented on one Leak Case Field Report for the station. All above grade leaks must be reported even if they are repaired at the time of the inspection.</p>	January 1, 2012	July 1, 2012
RNST 2.01	<p>4. A.: Added sentence to reinstating requirements when main is temporarily disconnected but not disturbed. "When reconnected, tie-in joints shall be leak tested with leak detection fluid with main under normal operating pressure."</p> <p>4. B.: Revised requirements when temporarily disconnected main is moved within the trench. Main shall be visually inspected to make sure that all joints are sound and no damage has been done to pipe. Main does not have to be pressure tested prior to reconnection. When it is reconnected the tie-in joints shall be leak tested with leak detection fluid with main under normal operating pressure.</p> <p>4. C.(1): Revised requirements when temporarily disconnected main is lifted out of the trench but is being returned to the same trench. Main shall be visually inspected to make sure that all joints are sound and no damage has been done to pipe. Main does not have to be pressure tested prior to reconnection. When it is reconnected the tie-in joints shall be leak tested with leak detection fluid with main under normal operating pressure.</p> <p>4. C.(2): Added requirement for a temporarily disconnected main that is lifted from the trench and reconnected in a different location. This main shall be pressure tested in the same manner as new lines in their final location. The pipe shall be visually inspected to make sure all joints are sound</p>	April 1, 2012	July 1, 2012

and no damage has been done to the pipe. When it is re-connected the tie-in joints shall be leak tested with leak detection fluid with main under normal operating pressure.

4. D.(3): New sentence added to requirements when mains are cut into sections: "Connections to the undisturbed sections of main shall be leak tested with leak detection fluid with the main under normal operating pressure.

SERV 3.01	1/2" CTS Service with flex riser: Minor revision to wording under Installation. Standardized PE designation PE2406/2708 and PE3408/4710 to match POLY 2.01. Modified wording the range of MAOP for PE2406/2708 and PE3408/4710	January 1, 2011	July 1, 2012
	Material List Tables: Expanded description for the risers to include PE3408/4710, SDR 7.0. Same riser is used for both PE2406/2708 and PE3408/4710 service lines.		
SERV 3.02	1/2" CTS Service with rigid riser: Minor revision to wording under Installation. Standardized PE designation PE2406/2708 and PE3408/4710 to match POLY 2.01. Modified wording the range of MAOP for PE2406/2708 and PE3408/4710	January 1, 2011	July 1, 2012
	Material List Tables: Expanded description for the risers to include PE3408/4710, SDR 7.0. Same riser is used for both PE2406/2708 and PE 3408/4710 service lines.		
SERV 3.03	1" CTS Service with flex riser: Minor revision to wording under Installation. Standardized PE designation PE 2406/2708 and PE 3408/4710 to match POLY 2.01. Modified wording the range of MAOP for PE 2406/2708 and PE3408/4710	January 1, 2011	July 1, 2012
	3.: Added new line: PE3408/4710 service line shall require a PE3408 riser that is SDR 7.0, Stock Number 19 72 139.		
	4.: Added new line: PE2406/2708 riser shall not be used on a PE 3408/4710 service.		
	5. Inserted new line: Caution: Electrofusion coupling is the ONLY approved means of connecting PE3408/4710 service line, SDR 11.5, with the PE3408/4710 riser, SDR 7.0. Butt fusion is not allowed when connecting two pipe sections with a wall thickness difference that exceeds one SDR value.		
	Material List Tables: Expanded description for the PE2406/2708 service riser to include PE2406/2708, SDR 11.5		
	Expanded description for the PE3408/4710 service riser to include PE3408/4710 SDR 7.0		
SERV 3.04	1" CTS Service with rigid riser: Minor revision to wording under Installation. Standardized PE designation PE 2406/2708 and PE 3408/4710 to match POLY 2.01. Modified wording the range of MAOP for PE 2406/2708 and PE3408/4710	January 1, 2011	July 1, 2012

3.: Added new line: PE3408/4710 service line shall require a PE3408 riser that is SDR 7.0, Stock Number 19 72 140. 4.: Added new line: PE2406/2708 riser shall not be used on a PE 3408/4710 service. 5. Inserted new line: Caution: Electrofusion coupling is the ONLY approved means of connecting PE3408/4710 service line, SDR 11.5, with the PE3408/4710 riser, SDR 7.0. Butt fusion is not allowed when connecting two pipe sections with a wall thickness difference that exceeds one SDR value.

Material List Tables: Expanded description for the PE2406/2708 service riser to include PE2406/2708, SDR 11.5 Expanded description for the PE3408/4710 service riser to include PE3408/4710 SDR 7.0

SERV 3.05	2" IPS Service: Minor revision to wording under Installation. Standardized PE designation PE 2406/2708 and PE 3408/4710 to match POLY 2.01. Modified wording the range of MAOP for PE 2406/2708 and PE3408/4710	January 1, 2011	July 1, 2012
--------------	---	--------------------	-----------------

3.: Added new line: PE3408/4710 service line shall require a PE3408 riser that is SDR 7.0, Stock Number 19 72 154.

4.: Added new line: PE2406/2708 riser shall not be used on a PE 3408/4710 service.

5. Inserted new line: Caution: Electrofusion coupling is the ONLY approved means of connecting PE3408/4710 service line, SDR 11.5, with the PE3408/4710 riser, SDR 7.0. Butt fusion is not allowed when connecting two pipe sections with a wall thickness difference that exceeds one SDR value.

Material List Tables: Expanded description for the PE2406/2708 service riser to include PE2406/2708, SDR 11.0

Expanded description for the PE3408/4710 service riser to include PE3408/4710 SDR 7.0

Added 6 new material tables for 2" PE3408/4710 service. Initial Standard did not include PE3408/4710 service line.

TURN 2.05	7. B.: Expanded information on Flammable Vapor Ignition Resistant (FVIR) hot water heaters. Conventional residential 50 gallons or smaller water heaters manufactured after July 1, 2003 had to be FVIR. Power vented residential water heaters 50 gallon and smaller manufactured after July 1, 2006 had to be FVIR. Finally all remaining residential water heaters manufactured after July 1, 2007 had to be FVIR. Residential FVIR water heaters installed in a garage do not have to be raised 18 inches off the floor.	January 1, 2011	July 1, 2012
--------------	--	--------------------	-----------------

7. F.: New: Added an example of the FVIR label that is attached to the water heater. This is the only visible way of verifying the water heater is FVIR.

	7. G.: New: Added an example of the label that is on non-FVIR water heaters.		
TURN 2.14	6. E.(2): Inserted new item for Changing of Meter Valves "On-The-Fly". "The operating pressure range of the service should be verified prior to changing the meter valve. Contact Gas Supervisor when or if there is a question on the operating pressure." This safety precaution should verify that the current operating pressure should not exceed that listed in the table for the various size valves.	January 1, 2011	July 1, 2012
VALV 1	<p>3. A.(1): Clarification that transmission line must have "sectionalizing block" valves spaced to meet the requirements for each Class location. These sectionalizing block valves are classified as Emergency Valves.</p> <p>3. A.(2): New: "Each section of transmission main between the sectionalizing block valve must have an emergency blow-down valve(s) with enough capacity to allow the line to be blown down as rapidly as practical." Generally, engineering practice is to size blow-down valves so that the section can be blown down in 30 minutes or less. This is not the case in all situations but is a general guideline.</p> <p>3. A.(3): New: "Each staffed compressor station with greater than a total of 1000 horsepower shall have emergency valve(s) and emergency blow-down valve(s) that shut off flow into the station." Requirement in Part 192.167.</p> <p>3. C.: Added reference to VALV 2.01 for installation of emergency valve used to control a regulator station.</p> <p>3. D.: New: "All emergency valves and emergency blow-down valves are to be entered in Ameren Illinois' electronic mapping system. System maps will distinguish these valves as Emergency Valves along with their respective Valve ID#,"</p> <p>3. E.: New: "All emergency valves shall be entered in Gas Compliance System with the same Valve ID # as that shown in the electronic mapping or on gas system maps</p>	January 1, 2011	July 1, 2012
VALV 2.02	<p>2. B.: Added requirement to "Verify valve ID on tag/label is correct and readable. Replace or schedule for replacement if needed."</p> <p>Made a distinction between below ground and above ground valves for leakage inspection.</p> <p>2. H.: "Below ground valves shall be checked for leakage with an approved gas detection instrument which reads percent gas-in-air on the LEL or Gas scale. Valve should have a final leakage check at the conclusion of the inspection."</p>	January 1, 2012	July 1, 2012

2. I.: "Above ground valves shall be checked for leakage with either a leak detection instrument or leak detection fluid at the conclusion of the valve inspection."

4. D.: Revision to language "Gas Supervisor should review the inspection sheets and other maintenance work listed in the GCS Valve Tracking Module "Other Work" tab. Added: Maintenance work that can be reported in Valve Tracking includes: replacement of valve number tags, miscellaneous work, mechanical maintenance, lubricate valve, new insulator needed, new gasket needed, data correction, clear vegetation, clear valve box,

Clean internal (flush), clean external, bond wire. And align valve box."

VALV 2.05	Correction of effective date on Page 2. Should be January 1, 2011 not 2010.	June 1, 2010	January 1, 2011
WELD 1	<p>1. C.: Added the O&M section references to the individual nondestructive testing procedures.</p> <p>6. B.(1): Added some clarification in the inspection and test of welds on pipeline that operates at or above 20% SMYS.</p> <p>"Welds that are visually inspected and approved by a qualified welding inspector need not be nondestructively tested if: (a) the pipe's nominal diameter is less than 6 inches or (b) the pipeline is to be operated at a pressure that produces a hoop stress of less than 40% SMYS and the welds are so limited in number that nondestructive testing is impractical."</p> <p>6. C.: New "The acceptability of a weld that is nondestructively tested or visually inspected is determined according to the standards in Section 9 of API Standard 1104. However, if a girth weld is unacceptable under those standards for a reason other than a crack, and if Appendix A to API 1104 applies to the weld, the acceptability of the weld may be further determined under that appendix. Contact Ameren Illinois Gas Training Center if assistance is needed to determine the acceptability of the weld."</p> <p>7. D.: New under Nondestructive Testing: "Welds on pipelines requiring nondestructive test will be tested in accordance with one of the approved methods contained in this section: WELD 2.06 - Radiographic Examination, WELD 2.07 - Magnetic Particle Inspection, and WELD 2.08 - Liquid Penetration Inspection."</p> <p>7. F.: Added a clarification to the situation where welder is isolated from the principal welding activity. If the weld meets the requirements in section 6. a sample of the welder's work for each day must be nondestructively tested.</p> <p>7. G.: Added the requirement "The actual radiographic film is to be stored in a manner such that it can be interpreted for</p>	January 1, 2012	July 1, 2012

at least 3 years. Gas Operations and Services - Engineering will file/store the film."

8. C.: Clarification under Repair or Removal of Defects: "The repair segment must be inspected in the same manner that the defect was found to ensure its acceptability."

8. E.: Minor, capitalized Heat Affected Zone

WELD 2.02	5. C. (2)(a): Correction under single qualification. Test 1 for the welder is two 1-1/4" butt welds on pipe less than 0.188 wall thickness. The original version was in error because it include less than or equal to 0.188 wall.	January 1, 2012	July 1, 2012
WELD 2.03	8. O.(1): Clarification in Welding Requirements under Pre-heating of Welds. Pyrometers can be either direct reading or infrared. 8. S.(3): Revised preheat temperatures to be consistent throughout the document. Preheat for stripper passes from a minimum of 200 degrees F to a maximum of 500 degrees F. 8. T.(2): Revised preheat temperatures to be consistent throughout the document. Preheat for back welding from a minimum of 200 degrees F to a maximum of 500 degrees F. 8. X.(8): Revised preheat temperatures to be consistent throughout the document. Preheat for weld repairs from a minimum of 200 degrees F to a maximum of 500 degrees F. The pyrometer can be either direct reading or infrared.	January 1, 2012	July 1, 2012

Supersedes: April 1, 2012

CHANGE SUMMARY

April 1, 2012

Change Summary April 1, 2012

Docu- ment	Change Summary	Previ- ous Docu- ment Dated	Current Docu- ment Dated
APPR 2.04	<p>3. F.: Change Covered Task Description for Course 0431 in Third Step Gas Technical Services Apprentice training to match the match same course in the Storage Field Apprentice training.</p> <p>0431 - Pneumatic Loaded Pressure Limiting/Relief Device-Inspect, Testing, Preventive & Corrective Maintenance</p>	Janu- ary 1, 2011	April 1, 2012
BORE 2.01	<p>3. E.: In Boring Site Evaluation inserted additional items to check for as evidence of subsurface facilities: cisterns, septic tanks, leach field piping, and sewer lateral cleanouts</p> <p>4. D. (3): Expanded sanitary system items that land owners are responsible for locating prior to boring operations: Now reads: Sanitary/septic system including drain tiles, leach fields, and tanks.</p> <p>4. D. (4): Added "Potable water wells and private water lines." to the list of items land owners should locate.</p> <p>4. L. Added reference to BORE 2.04 3. H. for sewer listening device requirements when locating and marking sewer lines and laterals prior to boring.</p>	Janu- ary 1, 2011	April 1, 2012
BORE 2.03	<p>3. A.: Expanded language on steel pipe coating by adding the "coating shall meet requirements contained in CORR 2.03" along with a coating inspection in accordance with CORR 2.15.</p> <p>3. C.: Clarified welded joint coating requirements for pipe being pulled back through a bore hole to make them consistent with CORR 2.03: Transmission and high pressure distribution pipe 2 inch and larger should be coated with liquid epoxy and covered with sacrificial hot wrap tape. Transmission, high pressure distribution pipe smaller than 2 inch and all sizes of distribution pipe can be coated with either liquid epoxy & sacrificial hot wrap or two layers of hot wrap.</p> <p>3. K.: Deleted: Coating requirements for transmission pipe and distribution pipe 2 inch and larger in diameter are in CORR 2.03 since it is covered in 3. C.</p>	Janu- ary 1, 2012	April 1, 2012
BORE 2.04	<p>1. B.: Added "services" along with PE mains that could be mistakenly installed through sewer lines.</p> <p>6.: Updated the Example Letter that is sent annually to local plumbers, city sewer departments and operators of sewer cleaning businesses advising them that boring, for the installation of a gas main and/or service, can enter a sewer line on some rare occasions, potentially causing a sewer problem.</p>	Janu- ary 1, 2012	April 1, 2012

UNCONTROLLED IF PRINTED

7.: Removed sample of door hanger since it was not the one currently is use. Current door hanger is in process of being updated with Ameren Illinois logo and single phone number 1-800-755-5000. Replaced with information on the door hanger, stock code number and Ameren Illinois phone number.

CNTS 1	<p>5. D. (9): New added to records to review for the System Review: "Inactive Services (Services inactive for 10 or more consecutive years) See SERV 2.05".</p> <p>7. B.: Revised: "The Gas Supervisor and/or Gas Engineer is responsible for completing the applicable portions of the system review report for their Operating Center(s). Removed Gas Supt from being responsible. 7. C.: New added: "Gas Operations and Services Supervisors (Corrosion Control, Pipeline Integrity, Tech Services) who have responsibilities for facilities within the Operating Center and Division should complete those sections of the system review and forward a copy to the appropriate Gas Superintendent for inclusion with his system reviews.</p> <p>7. D.: The Gas Superintendent is responsible for ensuring system review report for each Operating Center in the Division has been completed. The individual Operating Center reports can be submitted and do not have to be consolidated into a Division report. The completed report(s) shall be forwarded to Gas Compliance (PWN-427) upon completion.</p>	October 1, 2011	April 1, 2012
CNTS 4	<p>Form 01 - System Review has been updated: Replaced Operating Center for Division Added "Inactive Services" (Inactive for 10 or more yrs)</p>	October 1, 2011	April 1, 2012
CORR 0	<p>New CORR 2.03 6. - Trent #2A Wax Tape Application Procedures</p>	October 1, 2011	April 1, 2012
CORR 2.03	<p>1. A. (2)(a): In coatings for steel pipe installed by directional boring, added "high pressure distribution pipe 2" and larger to the same coating requirements as transmission pipe 2" and larger. Pipe shall be dual coated with initial layer of FBE and second layer of an abrasive resistant coating.</p> <p>Revised wording for coating on girth welds. Girth welds shall be coated with liquid epoxy and covered with sacrificial hot wrap. Tape is to be wrapped toward the pull head.</p> <p>1. A. (2) (b): Revised girth weld coating requirements on distribution pipe 2" and larger to include either: liquid epoxy and sacrificial hot wrap or two layers of hot wrap.</p> <p>Added the direction of wrap which is toward the pull head.</p> <p>A. (2)(c): Added coating requirements for all steel pipe smaller than 2" that is installed by directional drilling. Pipe shall be coated with fusion bonded epoxy (FBE), approximately 14 mils thick. Girth welds shall be coated with an approved hot or cold</p>	October 1, 2011	April 1, 2012

wrap or with liquid epoxy and sacrificial wrap. Tape shall be wrapped toward the pull head.

5. C.: Clarification: Cold applied wax tape can have a "mesh" outer wrap to protect the tape during backfilling. Glas-Wrap is a product name for the "mesh" wrap.

6. A. thru I.: New product added: Trent #2A Wax Tape. Bullet points A. thru I. are the application procedures for this wax tape.

7. A. (4): Added approved spray paint that can be applied primarily to gas facilities that are inspected annually. The approved spray paint can be used to touch-up small defects and bolts until a total repaint is necessary. Sherman-Williams Acrylic Modified Enamel - Meter Gray, Stock No. 30 51 579.

CORR 2.09	2. A.(8): Added "Dry Film Thickness Indicator" to required tools for applying Protal 7200 epoxy coating.	January 1, 2011	April 1, 2012
CORR 2.11	2. F.: Removed "(380 microns)" equivalent to the 15 mils	January 1, 2011	April 1, 2012
CORR 2.15	2. B.: Revised Inspection Voltage for Coating Inspection. Replaced the Coating Thickness vs Test Voltage Table with a condensed version based on Pipe Diameter. Inspection Voltage Table is divided into 2 tables: Standard FBE Coating and FBE Coating with Abrasive Resistant Layer. Added a Note: "For average thickness more than 2 mils thicker or thinner than indicated in the table above contact the Superintendent of Corrosion Control for proper testing voltages." 6. B.: Revisions on coating repairs: Reduced size of defect to 1/16" from 1/2" diameter on epoxy coated pipe that requires repair. Added "approved field applied liquid epoxy" for an approved epoxy coating repair method in addition to 1 complete wrap of an approved tape. 6. C.: Reduced size of defect to 1/16" from 1/2" diameter on Fusion Bonded Epoxy (FBE) coated pipe that requires repair. Added "approved field applied liquid epoxy" for an approved epoxy coating repair method in addition to the hot melt patch stick. 6. D.: Added "defects on coal tar coated pipe" should be repaired with full encirclement of an approved tape. This is same repair method as for defects in polyethylene coated pipe.	January 1, 2011	April 1, 2012
CORR 2.18	2. B.: Removed graph of "Potential vs Time" under -850 mV Polarized Potential under Cathodic Protection Criteria.	January 1, 2011	April 1, 2012

CORR 2.19	<p>4.: Added "as near to" and "as" in the first sentence. Clarifies that when measuring P/S at a major foreign pipeline crossing, the reading should be taken "as near" to directly over the actual crossing "as" possible. This allows flexibility in cases where the crossing is not readily accessible due surface conditions such as under pavement or water.</p> <p>5. C.: Corrected format by adding "C."</p>	Janu- ary 1, 2011	April 1, 2012
CORR 2.20	<p>5. D.: Corrected formatting by replacing "E." with "D."</p>	Janu- ary 1, 2011	April 1, 2012
CORR 2.21	<p>9. B.(2): Corrected Surface Area formula for calculating square feet of surface area.</p> <p>9. B. Schematic Notes: Typical Current Application at a residential meter set: Revised "Notes: 1." Removed the requirement that the interrupter "on cycle" does not have to be "3 times" the "off cycle". Added "(usually time on is longer than time off)</p>	Janu- ary 1, 2011	April 1, 2012
CORR 2.23	<p>2.: Updated the Stock Number for the 6" x 6" Insulator Square. Stock Number is 25 59 128 replaces the former IP stock number.</p>	Janu- ary 1, 2011	April 1 2012
CORR 2.24	<p>2.: Revised "When to Test" when checking for stray currents. Added "when rectifier installations are discovered near Ameren facilities" to the list of locations where low potential readings may indicate stray currents.</p> <p>3. A.: Added a clarification when performing test, potentials should be taken along the Ameren pipeline at 5 feet to 10 feet intervals which constitutes a "close interval survey".</p>	Janu- ary 1, 2011	April 1, 2012
CORR 2.25	<p>3. H. (2)(c): Added Stock Number for Over Voltage Protector</p>	Janu- ary 1, 2011	April 1, 2012
CORR 2.27	<p>6. B. (8): Revision to Point designation for the input taps to Point C from Points D & E on the typical rectifier circuit drawing in Troubleshooting Procedures</p> <p>6. B. (19): Correction made, changed "not" to "no". Now reads: "If DC voltage is present at the rectifier output terminals, but no current is flowing, there is an open in one of the external DC leads."</p> <p>8. B. (2): In Troubleshooting Tips, revised "If maximum DC output amps at rated DC volts is half output" there are checks listed that should be made. This is a revision from; If maximum DC output voltage at rated DC current is half output."</p> <p>8. C.: Revised Typical Rectifier Circuit drawing by adding a fuse between Points D and F.</p>	Janu- ary 1, 2011	April 1, 2012

8. D.: Added a second Rectifier Circuit Diagram.

CORR 2.28	2. B. (3): Deleted the Note below Table 1 that addressed wall thicknesses for pipe diameters not listed in table.	January 1, 2011	April 1, 2012
CORR 2.29	<p>1. B. (1)(a) & (1)(b): Major revision to Construction Order Review Process for projects prepared by the Belleville and Peoria Design Centers that have an impact on steel gas facilities. Revisions detail the involvement with Corrosion Control personnel during "Preconstruction - Proposed Work" and "Preconstruction - Final Design" processes.</p> <p>1. B. (1)(c): Revision made to the "Post Construction - As Builds" now include a table listing Corrosion Technician/Engineer responsible for Corrosion Control within each Division and Operating Area.</p> <p>1. C. thru 1. E. of the January 1, 2011 O&M have been deleted. Procedures by legacy companies have been deleted since project design will be performed by either the Design Centers in Belleville & Peoria or Gas Engineering.</p> <p>1. B. (2): Clarified Gas Engineering Work as "working designed outside of DDC process". Gas Engineering Work would typically be performed by Gas Operations and Services- Engineering or Division based Gas Engineer' 2. A. (7): Revision made to the instruction for Tracking Repair Orders on the CP Deficiency Tracking and Completed Orders SharePoint Site. Instructions now state: "Entering in the completion date removes the test point from this view but the re-read must be entered into CTS before entering the completion date in Share Point for the order. When the weekly update is done, the completed order is moved to the Completed Orders list.</p>	January 1, 2011	April 1, 2012
CORR 2.30	2. G. (5): Inserted New item when Buried Pipe Examination should be completed: "Retirement of a gas main or service - the form should be filled out for the main remaining in service after the retirement. If there is bare metal exposed on the steel main or if a steel service off of the steel main is retired, a pipe-to-soil potential shall be taken on the main remaining in service or on the steel service stub."	October 1, 2011	April 1, 2012
CORR 3.13	Added a second drawing showing test lead connections to the pipe adjacent to the insulated flanges as an alternate to connecting test leads to the flanges	February 1, 2010	April 1, 2012
CORR 3.15	<p>2. B.(1): Added the word "typically". " A 20' x 500' easement is typically required for the rectifier installation</p> <p>3.: Typical Rectifier Installation with Linear SPL (SOCK) Anode System has been deleted from Standard Design.</p> <p>3.: is now Rectifier Ground Bed Anode Installation</p>	January 1, 2011	April 1, 2012

- 3. A.: Added a Note below the drawing; "Overall canister length is 7 feet"
- 3. B.(3): Increased the recommended depth of anode hole to 10 feet from 9 feet.
- 3. C.: In the Material List for Stock No. 49 22 404, added to the anode package description "total length of package is 84" (7 feet)".
- 4. B.: In Rectifier Ground Bed Header Lead Connection now specifies a #4 & strand CP cable. This is a change from a #2 cable.

**DAMG
1**

- 3. E.: Deleted "When practical use white paint, flags or stakes to outline proposed excavation."
- 4. A.(6): New procedure added for personnel standing by on a difficult to locate gas facility. If the gas facility is exposed by the excavator, gas personnel should obtain and record measurements that can be used for future locating. Service line measurements should be recorded on the Service Transaction Card/Sheet or Service Record Card. Measurements taken on mains should be submitted to the appropriate group for recording on electronic gas system maps.

If the gas facility is PE pipe, gas personnel should check for the presence of a tracer wire. If tracer wire is in good condition, gas personnel should report it to their gas supervisor for follow-up to see if wire had possibly been cut and could be repaired.

January 1, 2012 April 1, 2012

**EMER
2.02**

- 3. D.: Updated contact information for Gas Technical Services personnel. During cold weather electrical outage dispatcher may need to contact GTS prior to restoring electrical service. Gerry Turner is initial contact with the other GTS supervisors as alternate contacts for their respective divisions.

January 1, 2011 April 1, 2012

**EMER
2.08**

- 1. B.: Added language that the Supervising Engineer of Distribution Integrity Management Program (DIMP) be involved in determining what actions should be taken as a result of failed material analysis.
- 2. F.: Updated the Failed Gas Material Tag and added the Stock Code number for the tag.
- 2. G. (4): Inserted a new item under actions Gas Compliance takes after being notified of failed or defective material: "Notify the Supervising Engineer of the Distribution Integrity Management Program of the failure and results of the pipeline."
- 2. G. (5): Deleted "and other identified gas operating personnel". Gas Coordinators will be notified and they will distribute the information to the appropriate operating personnel.

January 1, 2011 April 1, 2012

FORW

- 5.: Gerry Turner's name and phone numbers replaced Vern Maas in the Contacts

October 1, 2011 April 1, 2012

LEAK 2.01	1. B.: Deleted this item - "An indoor odor complaint should be responded to immediately." 1. A. states response to all leak and odor complaints in a priority manner.	October 1, 2011	April 1, 2012
LEAK 2.04	10.: Updated Ameren Illinois Leak Classification Guidelines card. Deleted classification for an Above Grade leak with Wall to Wall Paving since this is not an applicable classification	October 1, 2011	April 1, 2012
LEAK 2.07	2. A. (9)(f): Revised wording of an item to inspect for on meter set during Transmission Survey. "Corroded bolts on banded regulators. (Rockwell 8012, Lancaster Model 61, Universal Model 61)"	October 1, 2011	April 1, 2012
	2. A. (9)(g): Deleted requirement for notifying Gas Supervisor of banded regulators. Banded regulators with corroded bolts are to be reported as indicated in (f).		
	2. B. (7)(f): Revised wording of an item to inspect for on meter set during Distribution Survey. "Corroded bolts on banded regulators. (Rockwell 8012, Lancaster Model 61, Universal Model 61)"		
	2. B. (7)(g): Deleted requirement for notifying Gas Supervisor of banded regulators. Banded regulators with corroded bolts are to be reported as indicated in (f).		
	2. C. (12)(h): Revised wording of an item to inspect for on meter set during Business District Survey. "Corroded bolts on banded regulators. (Rockwell 8012, Lancaster Model 61, Universal Model 61)"		
	2. C. (12)(i): Deleted requirement for notifying Gas Supervisor of banded regulators. Banded regulators with corroded bolts are to be reported as indicated in (h).		
	2. E. (8)(h): Revised wording of an item to inspect for on meter set during Inside Meter Survey. "Corroded bolts on banded regulators. (Rockwell 8012, Lancaster Model 61, Universal Model 61)"		
	2. E. (8)(i): Deleted requirement for notifying Gas Supervisor of banded regulators. Banded regulators with corroded bolts are to be reported as indicated in (h).		
LEAK 2.08	2.: Added "Portable" to Flame Ionization Instrument to distinguish between the hand-held and mobile FI instruments.	October 1, 2011	April 1, 2012
	2. E.: Expanded language for inspecting and calibrating an FI unit by stating inspection and calibration shall be performed in accordance with manufacturer's operating manual. See LEAK 4 which has the various manufacturers' operating manuals		
	2. F.: Revised language to state "Follow the manufacturer's operating manual instructions for the FI unit being used for start-up procedures, required maintenance such as filters, daily operational checks and operating instructions.		

- 3. I.: Added to Gas Detection Instruments, "Follow the instrument's operating/instruction manual for calibration procedures, daily operational check, instrument inspection and maintenance, and operating instructions. See LEAK 4."
- 4. F.: Added to Combustible Gas Indicator instruments, "Follow the instrument's operating/instruction manual for calibration procedures, daily operational check, instrument inspection and maintenance, and operating instructions. See LEAK 4."
- 6. D.: Expanded language for inspecting and calibrating an FI unit by stating inspection and calibration shall be performed in accordance with manufacturer's operating manual. See LEAK 4 which has the various manufacturers' operating manuals
- 6. E.: Revised language to state "Follow the manufacturer's operating manual instructions for the FI unit being used for start-up procedures, required maintenance such as filters, daily operational checks and operating instructions.
- 6. F.: Deleted "Filters in the sampling tubes mounted on the front of the vehicle should be checked daily and replaced weekly when being used continuously for leak survey." This would be included in manufacturer's instructions.
- 7. B.: Added daily checks and maintenance for the Remote Methane Leak Detector (RMLD) be in accordance with manufacturer's operating manual.
- 8. F.: Added daily checks and maintenance for the Optical Methane Detector (OMD) be in accordance with manufacturer's operating manual.

<u>LEAK</u> <u>2.09</u>	1. G.: Inserted new: "In agricultural areas, leak survey should be performed when the height or density of crops will not hinder the surveyor in walking the approximate location of the gas line or the ability to detect leakage."	January 1, 2012	April 1, 2012
<u>LEAK</u> <u>4</u>	Form 05 updated, removed Send to Gas Compliance Specialists since the information can be entered into GCS by local operations	January 1, 2012	April 1, 2012
<u>MAIN</u> <u>1</u>	3. A.: Removed "A depth of 30 inches is recommended for distribution and high pressure distribution mains." from below the minimum depth table.	January 1, 2012	April 1, 2012
METR 0	Title change in METR 2.14 7. Atmospheric Corrosion Inspection Follow-up METR 4: Added Reference 05 - Fisher CS800 Series Instruction and Parts Manual	January 1, 2012	April 1, 2012
METR 2.04	4. C.: Updated the Periodic Testing requirements for a ultrasonic meter. Ultrasonic meter must be interrogated twice a calendar year, not to exceed 7-1/2 months. The pressure and tem-	January 1, 2011	April 1, 2012

perature transducers shall be calibrated at the same time as the meter is interrogated.

METR 2.14	2. B.: Revised: "Supervisor Gas Metering will establish the correctors to be inspected each calendar year and have OAS orders created."	January 1, 2011	April 1, 2012
	2. C.: New added: "The Gas Technical Services Supervisor is responsible for scheduling the annual inspection of electronic correctors."		
	5. B.: Added "F." behind $\pm 1^\circ$		
	6. C.(1): Expanded instructions for Battery Maintenance when main battery has low reading. "If the voltage is at or below 5.50 volts for the 9 volt replacement packs and 4.3 volts for the 6 volt receptacle packs, replace the battery pack or the D-cell batteries."		
	6. D. (2): New added in the Follow-up Action: "Proper notification of potential billing adjustments shall be communicated to CAD by the GTS Supervisor."		
	6. E.: New added Atmospheric Corrosion Inspections;		
	6. E.(1): New: Atmospheric Corrosion (Y/N)		
	6. E.(2): New: Disbonded Coating (Y/N)		
	6. E.(3): New: Needs Painting (Y/N)		
	7.: New: Atmospheric Corrosion Inspection Follow-up 7. A.: New: Gas metering facilities that have any of the corrosion control inspection activities marked (Y) for YES shall be documented in the Gas Compliance System for tracking and scheduling of any follow-up actions that are required.		
	7. B.: After initial review by the immediate Gas Supervisor, the appropriate information shall be sent to the Superintendent Corrosion Control, (Mail Code D-47), for final review and data entry into GCS.		
	7. C.: The corrective action work required will follow the procedures identified in the Corrosion Control section (CORR) of the Gas Operating and Maintenance Plan.		
	8. A.: New in Records: The electronic corrector inspections shall be completed in OAS.		
	8. C.: New in Records: The completed form shall be reviewed by the GTS supervisor and forwarded to IL Metering.		
METR 3.01	Correction on Roots 5 / 5.5 M 175 and on Note 3. American 5.5M. Original had 5.3M	January 1, 2012	April 1, 2012
METR 3.03	2.: Added a Stock Number for the 3/4"x 1" American 1813C, 1/4" orifice plus added (4) footnote that addresses inlet pressure greater than 48 psig and required relief valve.	January 1, 2012	April 1, 2012

Added (4) footnote to 1" x 1" American 1813C, 1/4" orifice for inlet pressure greater than 48 psig and required relief valve.

Added 1-1/4" American 1813C-HC, 1/4" orifice to the approved regulators for 7" w.c. delivery.

Replaced the 2" Fisher S203's with 2" Fisher CS803-IT regulators. Note the change in orifice sizes: 1/4" orifice is now 3/8" x 1/4", the 3/4" orifice has been replaced by a 5/8" orifice, and the 1".

Revised Note 3. To reflect the Main and Monitor springs for the Fisher 803-IT

Added Note 4. That addresses the relief valve size and spring setting required for operating pressures greater than 48 psig for the American 1813C and 1813C-HC regulators.

METR 3.04	<p>2.: Added a Stock Number for 3/4" x 1" American 1813C, 1/4" orifice for delivery pressure of 2 psig.</p> <p>Added 1-1/4" American 1813C, 1/4" orifice to the approved 2 psig delivery pressure regulators.</p> <p>Replaced the 2" Fisher S203H regulators with 2" Fisher CS823-IT regulators. Note the change in orifice sizes: 1/4" orifice is now 3/8" x 1/4" and the 3/4" orifice has been replaced by a 5/8" orifice.</p> <p>Note 5. Revised to reflect Main and Monitor springs for the Fisher CS823-IT regulators.</p>	Janu- ary 1, 2012	April 1, 2012
METR 3.05	<p>2.: New added 2" Fisher CS823-IT, 1/2" orifice and 2" Fisher CS823-IT, 3/4" orifice regulators to the approved 5 psig delivery pressure regulators. Provided capacity information.</p> <p>Changed the note designation to (2) for the 2" Fisher 299H, 1/2" orifice with inlet pressure of 60 psig.</p> <p>Replaced Note 3. with Main and Monitor spring specifications for the 2" Fisher CS823-IT.</p>	Janu- ary 1, 2011	April 1, 2012
METR 3.06	<p>2.: Inserted 1-1/4" Fisher CS400IR, 1/4" orifice as an approved alternate regulator for 7" w.c. delivery. Capacity information is included.</p> <p>Added Note 6. with Main spring specification, and instructions not to exceed 54 psig MAOP due to limited internal relief capacity.</p> <p>3.: Inserted 1-1/4" Fisher CS400IR, 1/4" orifice as an approved alternate regulator for 2 psig. delivery. Capacity information is included.</p> <p>Added Note 6. with Main spring specification and set point information.</p>	Janu- ary 1, 2012	April 1, 2012

METR 3.07	Meter Set Design Standards: Added Maximum Emergency Pressure (MEP) for 7" w.c., and 2 psig delivery pressures.	January 1, 2012	April 1, 2012
thru METR 3.14	Maximum Emergency Pressure is 2 psig downstream of meter set for 7" w.c. delivery pressure. Maximum Emergency Pressure is 6 psig downstream of meter set for 2 psig delivery pressure.		
METR 3.16	Revised 15C Compact Meter Set, 7" w.c., to reflect new Fisher CS803-IT regulator. Revised Material List to reflect new regulator and deleted a nipple and elbow formerly used in vent. Installation 2.: Added - Maximum Emergency Pressure (MEP) is 2 psig downstream of meter set	April 1, 2010	April 1, 2012
METR 3.17	Revised 15C Compact Meter Set, 2 psig, to reflect new Fisher CS823-IT regulator. Revised Material List to reflect new regulator and deleted a nipple and elbow formerly used in vent. Installation 2.: Added - Maximum Emergency Pressure (MEP) is 6 psig downstream of meter set	April 1, 2010	April 1, 2012
METR 3.18	Revised 15C/3M Meter, 7" w.c., to reflect new Fisher CS803-IT regulator. Revised Material List to reflect new regulator and deleted a nipple and elbow formerly used in vent. Installation 2.: Added - Maximum Emergency Pressure (MEP) is 2 psig downstream of meter set	April 1, 2010	April 1, 2012
METR 3.19	Revised 15C/3M Meter Set, 2 psig, to reflect new Fisher CS823-IT regulator. Revised Material List to reflect new regulator and deleted a nipple and elbow formerly used in vent. Installation 2.: Added - Maximum Emergency Pressure (MEP) is 6 psig downstream of meter set	April 1, 2010	April 1, 2012
METR 3.20	Installation inserted 2. Maximum Emergency Pressure is 10 psig downstream of meter set for 5 psig delivery pressure.	April 1, 2010	April 1, 2012
METR 3.21	Revised 5M/7M, 7" w.c., to reflect new Fisher CS803-IT regulator. Revised Material List to reflect new regulator and deleted a nipple and elbow formerly used in vent. Installation 2.: Added - Maximum Emergency Pressure (MEP) is 2 psig downstream of meter set	April 1, 2010	April 1, 2012
METR 3.22	Revised 5M/7M Meter Set, 2 psig, to reflect new Fisher CS823-IT regulator. Revised Material List to reflect new regulator and deleted a nipple and elbow formerly used in vent. Installation 2.: Added - Maximum Emergency Pressure (MEP) is 6 psig downstream of meter set	April 1, 2010	April 1, 2012

METR 3.23	Maximum Emergency Pressure is 10 psig downstream of meter set for 5 psig delivery pressure.	April 1, 2010	April 1 2012
METR 4	Added Reference 05 - Fisher CS800 Series Instruction and Parts Manual	Janu- ary 1, 2011	April 1, 2012
PMRK 3.02	1.: Updated Carsonite pipeline marker sticker that has the 1-800-755-5000 phone number. Added a table for the Replacement Sticker with Stock Number.	Janu- ary 1, 2011	April 1, 2012
POLY 2.02	2. B.: Added "Inspect the pipe for damage" to the sentence "clean the area where the squeeze is to be made."	May 1, 2010	April 1, 2012
POLY 3.02	4.: Stock Code 19 22 351 originally assigned to the Innogaz 2"IPS x 1 1/4"IPS has been combined with Stock Code 19 22 248 which was originally assigned to the Friatec reducer coupling. Currently, only the Innogaz reducer coupling is being purchased and stocked under 19 22 248.	Janu- ary 1, 2012	April 1, 2012
PTRL 2.01	2. B. Table: Removed "Critical Area Patrols" from column heading.	Janu- ary 1, 2012	April 1, 2012
PTST 0	In PTST 2.04 added 4. Utilizing Compressed Gas Cylinder	Octo- ber 1, 2011	April 1, 2012
PTST 1	3. A.: Added "PE and Steel" in front of distribution main. 3. E.: Inserted procedures for required testing of farm tap piping. 3. E. (1): Testing procedures for farm taps with a single pressure reduction. 3. E. (2): Testing procedures for farm taps with two stage pressure reduction. 3. E. (3): Regulator(s) and relief valve shall be removed during pressure test. 3. E. (4): Following the pressure test, the regulator(s) and relief valve connections shall be soap tested at normal operating pressure. 4. D.: New: "PE pipe shall not be hydrostatically pressure tested. 7. B.: Added two additional items to the Pretested Appurtenances: Kerotest & PSI Weld-in Insulators and Kerotest Rotary Meter Loops.	Janu- ary 1, 2012	April 1, 2012

PTST 2.04	<p>4: New item inserted: Utilizing Compressed Gas Cylinder 4. A.: An adjustable regulator with gauges for upstream and downstream pressures is required for pressure testing applications.</p> <p>4. B.: Regulator, valves, gauges, hoses, and fittings designed and rated for the intended application and pressure shall be used. 5. C.: Added under Tube Trailer Requirements: "If nitrogen is used, initial cooling may occur causing the pressure to rise. If Nitrogen from a liquid transport is used, ensure only vaporized nitrogen is introduced in the pipe."</p>	January 1, 2011	April 1, 2012
REPR 1	<p>1. L.: Additional wording added to emphasize importance of contacting corrosion control personnel when the repair of steel pipe involves installing a section of PE pipe. Corrosion control personnel must ensure the cathodic protection of the affected pipeline segment is being met, maintained, and is adequate.</p> <p>2. F.: Added "Corrosion and Steel Damage Evaluation shall be completed by the appropriate and qualified individual. See CORR 2.31" when there is a leak repair is a result of corrosion.</p> <p>2. G. New item added "Depending on the condition of the pipe, pipe coating and extent of the corrosion, Corrosion Control personnel should determine if further investigation and testing is needed to ensure adequate cathodic protection is being maintained."</p> <p>4. C. (1): In Non-Leaking Pipe Defects added a sentence "See Approved Repair Methods tables as to when deposition welding can be used."</p> <p>4. H.: Welded Full Encirclement Split Sleeve section has been revised. Previous references to the 1/4" vent holes have been moved to the WELD 2.04 which contains installation instructions.</p> <p>4. H. (3): New items that address preparing the pipe for the installation of the full encirclement sleeve: cleaning the pipe and removing the coating. If there is severe corrosion present, Gas Supervisor should be contacted to determine if split sleeve is appropriate. Gas Supervisor may need to consult with Gas Engineering and/or Corrosion Control personnel.</p> <p>4. H. (5): Added "Welding of the full encirclement sleeve shall be in accordance with manufacturer's instructions and WELD 2.04.</p> <p>8. A.: Under Service Line Repairs added "Compression couplings can be used for Make Safe repairs on distribution service."</p>	January 1, 2012	April 1, 2012
RNST 0	<p>RNST 2.01: Inserted new: RNST 2.01 3. Reconnection of Temporarily Disconnected Farm Tap Services</p>	January 1, 2012	April 1, 2012

RNST 2.01	<p>3.: Inserted a new item "Reconnection of Temporarily Disconnected Farm Tap Services"</p> <p>3. A.: New: "When possible it is recommended that only the regulator head be removed, leaving the regulator body connected to the farm tap piping. Utilizing this method will not require testing the service line prior to replacing the regulator because the service line has not been disconnected from the gas source."</p> <p>3. B. (1) & (2): New: Provides the testing requirements for existing single stage and two-stage farm taps if the regulator(s) have been removed from the farm tap piping. Single stage farm taps require testing of the service line at 90 psig. Two-stage farm taps require testing of the piping between the two regulators to be tested at 1.5 times the inlet MAOP, PTST 1 and PTST 2.01. The service line from the outlet of the second regulator is to be tested at 90 psig.</p> <p>3. B. (3): New: "Regulators and relief valves shall be removed during the pressure test."</p> <p>3. C: New: "Regulator and relief valve connections shall be soap tested at normal operating pressure once service has been reinstated."</p>	January 1, 2012	April 1, 2012
SERV 1	<p>8. G.: Delete the word "General" from the first sentence. Inserted references to Service Standards, SERV 3.01, 3.02, 3.03 and 3.04, to be followed when installing either a flex riser or a rigid riser. 9. C.: New inserted: "Service line being pressure tested shall be disconnected from the meter set or customer piping while the line is under test and until the test pressure has been released."</p>	January 1, 2012	April 1, 2012
SERV 2.03	<p>4.: Testing of farm tap piping section was rearranged and wording revised.</p> <p>4. A.: Revised wording to simply state that farm tap piping shall be tested in accordance with PTST 1 which specifies procedures for farm tap piping.</p> <p>4. C.: Revised to specify all connections between the inlet riser and outlet riser shall be soap tested at operating pressure after regulator(s) and relief valve are installed.</p>	January 1, 2011	April 1, 2012
STLP 1	<p>10. Buried Pipe Examination</p> <p>11. Corrosion and Steel Damage Evaluation</p> <p>These items were listed on the October 1, 2011 O&M update but were inadvertently left off the January 1, 2012 O&M update.</p>	January 1, 2012	April 1, 2012
VALV 2.01	<p>4. C. (1): Added "Any work or equipment change that increases station capacity is considered a rebuild." Clarification on what constitutes a rebuild for pre - March 31, 1971 stations.</p>	January 1, 2011	April 1, 2012

4. C. (3)(c): Added "with same or equivalent as long as station capacity does not increase" to distinguish between maintenance work and station rebuild.

4. C. (3)(i): Added "as long as station capacity does not increase" to distinguish between maintenance work and station rebuild.

WELD 0	Added Reference 47 under WELD 4	January 1, 2012	April 1, 2012
WELD 2.04	<p>1. B.: Removed the word "petroleum" from in front of gas. Maintenance welding is any welding performed on pipeline or pressure piping system that contains gas or any liquid under static or flowing conditions.</p> <p>6. D. (2): Insert new item that addresses utilizing the vent holes in the full encirclement sleeves for venting of gas during repair. An appropriate weld fitting should be welded over the vent hole. The vent stack would be connected to the weld fitting. Following completion of repair, a steel plug/cap would be installed in the weld fitting and welded to prevent removal.</p> <p>6. D. (12): Added "The sleeve shall be coated with an approved coating. See CORR 2.03"</p>	January 1, 2012	April 1, 2012
WELD 2.09	<p>3. A.: Added personnel operating the thickness gauge shall be thoroughly familiar with manufacturer's instructions in the operation, application, and calibration of the instrument.</p> <p>3. B: Deleted the sentence about personnel using the ultrasonic wall thickness instrument having to demonstrate their proficiency to authorized Ameren Representative.</p>	January 1, 2012	April 1, 2012
WELD 4	Added Reference 47: ENE - Ameren-ISW-02 Thin Wall, GMAW welding procedure specification and supporting welding procedure qualification report. (Wire, in-service welding procedure)	January 1, 2012	April 1, 2012

Supersedes: January 1, 2012

CHANGE SUMMARY

January 1, 2012

Change Summary January 1, 2012

Docu- ment	Change Summary	Previ- ous Docu- ment Dated	Current Docu- ment Dated
BORE 2.02	<p>2. H.: Inserted "and where applicable exposed" so that the sentence reads: Underground utilities shall be located, marked, and where applicable exposed prior to proceeding with boring operations.</p> <p>3. A. (2): Added under Conventional Rod Boring: All marked buried facilities crossing the proposed bore path or are within the 18" tolerance zone should be exposed or verified not to be in conflict with boring and back reaming operations. Pot holes should be of such depth to ensure the buried facilities will not be damaged by boring and back reaming operations.</p> <p>3. A. (3): Clarified an in-depth job briefing covers all of the subjects on the Job Briefing Form with a reference to EXCV 4 which has a copy of the form.</p> <p>4. A. (1) - (3): Revised by using essentially the same language as used under 3. Conventional Rod Boring - A. Prior to beginning pneumatic piercing tool operations: Ensure proper job site protection, expose or verify buried facilities crossing or are within 18" of bore path are not in conflict, and conduct in-depth job briefing.</p> <p>4. A. (3): Clarified an in-depth job briefing covers all of the subjects on the Job Briefing Form with a reference to EXCV 4 which has a copy of the form.</p> <p>4. M. (4): Added a 4th item that workers should check while the piercing tool is in operation: Observe the pot holes as the piercing tool passes the pot hole(s).</p> <p>5. A. (1) - (5): Revise to use consistent language for "Prior to beginning operation" as used under Pneumatic Piercing Tool and Conventional Rod Boring operation.</p> <p>5. A. (1): Revised wording to clarify that the drilling supervisor should visually inspect the planned drill path to ensure all known buried utilities and substructures that cross or are within the 18" tolerance zone have been identified, exposed, or verified not to be in conflict with the boring or back reaming operations.</p> <p>5. A. (2): Inserted a new item: If sewer line, main or laterals, are not exposed or their depth are not verified, Gas Supervisor should refer to BORE 2.04 for available options. BORE 2.04 is Boring Across or Near Sewer Lines.</p> <p>5. A. (4): Inserted a new item: Ensure proper job site protection and required traffic control is in place.</p>	Janu- ary 1, 2011	Janu- ary 1, 2012

UNCONTROLLED IF PRINTED

5. A. (5): Inserted a new item: Gas Supervisor, crew leader, or foreman should conduct in in-depth job briefing covering all of the subjects on the Job Briefing Form with entire crew.

5. L.: Changed "Test holes can be used" to "Pot Holes should be used".

5. AA.: Inserted "Pot holes should be used to observe the back reamer as it passes to ensure there is no damage to exposed utilities and other structures."

5. EE - 5. GG.: Moved the following items from BORE 2.03 4. I. thru K. Items address disposal of drilling mud and spoils associated with directional boring.

5. EE.: Dispose excess drilling mud in compliance with local ordinances, regulations, and environmentally sound practices.

5. FF.: Biodegradable additives for producing drilling mud are available.

5. GG.: Spoils and drilling fluids are not permitted to be disposed of into storm, sanitary, or other drainage systems.

BORE 2.03

1. E.: Added "Installing pipe should be planned so that back-reaming and pull in for a leg can be completed on the same day."

Janu- ary 1, 2011	Janu- ary 1, 2012
-------------------------	-------------------------

2. H.: Added "breakaway device" as an option to a weak link that can be used when pulling PE pipe through bore hole.

2. J.: Deleted reference to table number for the Maximum Load Tension.

2. K.: Inserted new item: Shear pins that do not exceed the maximum load tension of the pipe being pulled should be installed in the breakaway device."

2. S. - X.: These items were originally under BORE 2.03 4. PE and Steel Pipe. ICC requested they be put under the separate PE Pipe and Steel Pipe sections.

2. S.: "If possible, the pipe and back reamer should be observed as they pass through the pot holes"

2. T.: "It is recommended that an additional length of pipe that is 1% of the length of pull or 10 feet, whichever is greater, be pulled through the entrance pit" Added reference to REPR 1 if damage has occurred to pipe.

2. U.: "The annular region between the pipe and the bore-hole should be filled with drilling mud....."

2. V.:" Drilling mud in this annular region should not be removed after installation, but permitted to solidify...."

2. W.: "Pipe should be pulled into the hole before the drilling mud sets up."

2. X.: "An additional pipe length, sufficient for joining the next segment, should be pulled into the entrance pit."

UNCONTROLLED IF PRINTED

2.: Maximum Allowable Load Tension (ATL) table: Updated with revised Maximum Allowable Load Tension that can imposed on MDPE and HDPE pipe as it is being pulled through the bore hole or plow trench. Maximum tension was calculated using Performance Pipe technical references. The maximum pull length of pipe has been deleted from the new table.

3. C.: Inserted new item: "Weld joints will be coated with liquid epoxy and covered with a sacrificial hot wrap tape or two layers of hot wrap tape. Tape shall be applied toward the pulling head of the pipe. A sacrificial piece of tape may be applied to the lead edge to help prevent any rollback of the tape."

3. E. - J.: These items were originally under BORE 2.03 4. PE and Steel Pipe. ICC requested they be put under the separate PE Pipe and Steel Pipe sections.

3. E.: "If possible, the pipe and back reamer should be observed as they pass through the pot holes"

3. F.: "It is recommended that an additional length of pipe that is 1% of the length of pull or 10 feet, whichever is greater, be pulled through the entrance pit" Added "depending on nature of damage, contact Gas Operations and Services engineering and/or corrosion control personnel to determine extent of investigation and procedures to utilize. Added reference to REPR 1.

3. G.: "The annular region between the pipe and the bore-hole should be filled with drilling mud....."

3. H.: " Drilling mud in this annular region should not be removed after installation, but permitted to solidify...."

3. I.: " Drilling mud in this annular region should not be removed after installation, but permitted to solidify...."

3. J.: "An additional pipe length, sufficient for joining the next segment, should be pulled into the entrance pit."

BORE 2.04

2. C.: Revised to "Consider obtaining maps and drawings of sewer system from the city or other entity. Maps can provide location and approximate original installation depth" ICC pointed out the depth on these maps may not be accurate today due to changes in surface configuration. Maps should provide a good indication of location.

Janu- ary 1, 2011	Janu- ary 1, 2012
-------------------------	-------------------------

2. F.: Revised by adding "Regardless of which step is taken to identify potential conflict with sewer line the only way to verify location and depth of sewer main or lateral is by physically exposing the line. If location of the line is known, excavate a sufficient depth below the proposed bore path to verify the sewer line is deep enough that it will not be damaged by the drill head or back reamer."

2. F. (1): Revised to "Access available outside and inside clean-outs and measure depth of the sewer line lateral. Use of steel tape or similar item and a pipe locator may assist in determining location of sewer lateral. Worker should avoid direct

contact with contents of the sewer line by using rubber/neoprene gloves, protective eye wear, and coveralls." ICC pointed out that locators should not be used to determine depth of sewer line.

2. F. (3): Added a sentence when obtaining depth of sewer line by measuring at manholes. "On gravity flow sewer mains, it is reasonable to assume sewer line has a constant grade between manholes. The depth to the top of pipe below the surface can be determined based on that fact. The same is not true for forced sewer systems."

2. F. (4): Combine two bullet points with regards to estimating approximate depth of sewer base on where it exits the structure. Drawings that represent typical sewer installation can be found at the end of this section.

2. F. (5): Repeated that sewer lateral depth must be verified by exposing or excavating a sufficient depth below the proposed bore path to ensure the lateral will not be damaged by the drill head and/or back reamer.

2. G.: Inserted new item concerning forced sewer lines. "Forced sewer system mains and laterals must be physically exposed or pot holes excavated to a sufficient depth below, below proposed bore path to ensure the sewer line will not be damaged by drill head or back reamer."

2. H.(3): Inserted " Use of sewer listening device as described below in 3. H." to the options that can be used when location of sewer lines and laterals cannot be positively identified.

3. D.: Revised to "Every effort should be made to maintain a separation of 1 foot between buried utilities and structures upon final installation of the gas main and/or service. Added reference to MAIN 1 or SERV 1 which describe measures that can be taken when separation is less than 1 foot.

<u>CONS</u> <u>0</u>	Corrected "affective date" from January 1, 2010 to January 1, 2011	January 1, 2010	January 1, 2011
<u>CONS</u> <u>1</u>	5. C.: Quality Assurance forms are to be sent to the Superintendent Gas Quality Assurance.	October 1, 2011	January 1, 2012
<u>DAMG</u> <u>0</u>	DAMG 1 revised to 7.: Excavating Near a Transmission, High Pressure Distribution, or 8" and Large Main 8.: Emergency Locate Requests Near Gas Transmission, High Pressure Distribution, or 8" and Larger Main 9.: Facility Location Information 10.: QA Process	January 1, 2011	January 1, 2012

UNCONTROLLED IF PRINTED

DAMG
1

- 4. A.: Deleted "Normal" since all JULIE Requests are handled in same manner.
- 4. A. (1): Revised to provide more detail in how JULIE reviews Requests and determines when a Dig Request Notice should be sent to Ameren Illinois requesting their facilities to be located and marked.
- 4. A. (2): Revised to provide more detail on how Ameren Illinois reviews JULIE Dig Request Notices to determine which facilities need to be located and marked.
- 4. B. (1): Revised - JULIE transmits Emergency Locate Requests directly to Ameren Illinois. Following a quick review, the Emergency Ticket can either be cleared or transmitted to the appropriate locating contractor.
- 4. C. (2): Clarified that paint or flags will be used to mark an excavation when no facility is present. Marking an excavation is one of the options for providing a response when Ameren Illinois does not have buried facilities present.
- 5. F.: Added an item for providing Damage Prevention information to excavator who is not calling JULIE prior to digging. When Ameren Illinois becomes aware of such contractor the contractor will be contacted, information provided and their name will be added to the list of known excavators.
- 7.: The entire section has been replaced with new procedures that describe actions now being performed under Ameren Illinois Damage Prevention's Watch & Protect program for excavations conducted within 15 feet of all gas transmission or high pressure distribution mains, or an 8" or larger gas main. Procedures outline the duties of the qualified personnel who monitor such excavations.
- 8.: The Emergency Locate Request Near Transmission Mains has now been expanded to also include all high pressure distribution mains and all mains 8" and larger.
- 9.: The original bullet point "9." has been deleted and those items have been incorporated into bullet point "7".
- Former 10. now is 9.: Revised to state that Operating Divisions and Business Unit is responsible for ensuring that "as-built" information is being submitted in a timely fashion to those individuals or groups responsible for maintaining the electronic gas system maps for their respective areas of responsibility. The Divisions or Business Units are not responsible for maintaining the maps since mapping is in process of being centralized.
- 10.: New section added that describes the Damage Prevention group Quality Assurance process for monitoring the performance of the locating company(s).

October 1,
2011

January 1,
2012

EXCV
2.03

- 2. B.: Revised to make consistent with EXCV 2.04 6.D. Excavation/Soils Checklist is required each day an excavation is left open and workers are entering the excavation. Clarified a

January 1,
2011

January 1,
2012

checklist is required when workers are entering the excavation. A daily checklist is not required for excavations left open and workers are not entering the excavation.

3. F. (2): Revised wording to a ladder that is labeled as meeting OSHA requirements. OSHA does not approve items.

GLOS

Added the following definitions:

Clean Construction or Demolition Debris (CCDD)

Pipeline Maintenance Welding

Qualified Welder

Qualified Welding Procedures

Uncontaminated Soil

Welder

October 1, 2011

January 1, 2012

INCD
0

Inserted new item: INCD 1 4. Service Interruption/Curtailment Notification which moved other items down one number

Changed INCD 1 7. To Reporting Matrix from Incident Reporting Matrix

INCD 4: Updated Potential Incident Report Form

January 1, 2011

January 1, 2012

INCD
1

2. A. (3): Revised: Deleted the "cost of lost gas" from: Estimated property damage exceeding \$25,000, including loss to Ameren Illinois and/or others.

2. A. (4)(e): Removed "Gas service interruption to more than 500 customer" from "Significant Event" that is reported in same manner as a Natural Gas Incident.

3. A. (1): Clarified when courtesy notification to the ICC as a result of "Fire and Police Emergency Response to a release of natural gas by moving items originally listed separately as 3. A. (3), 3. A. (4) and 3. A. (5) to a subset of 3. A. (1). This is meant to eliminate reporting every time the fire or police respond or are on the scene of a gas event.

3. A. (1) (a): Release of natural gas from Ameren Illinois facility that would result in evacuation of more than one residential customer.

3. A. (1) (b): Evacuation of multiple occupancy buildings such as restaurant, store, apartment, school, church, hospital, nursing home, factory, etc.

3. A. (1) (c): Closure of major road, highway, railroad, etc.

4.: Inserted a new item: Service Interruption/Curtailment Notification that lists events that are reported to IEMA and ICC.

4. A.: Gas service is interrupted to more than 500 customers or

4. B.: Supply or pressure problems cause the Company to curtail firm load to more than 50 customers.

October 1, 2011

January 1, 2012

6.: Updated by removing Tom Stassi from the Gas Compliance Contact List.

7.: Changed name to Reporting Matrix since it addresses more than a Natural Gas Incident.

7. Matrix Table: Items rearranged to match PHMSA's listings. Added a new item "Unintentional estimated gas loss of 3,000 MCF or more" Table also includes IEMA notification events.

<u>INCD</u> <u>4</u>	Form 03 - Potential Incident Report Form updated. The Reporting Matrix was renamed and rearranged to match the Reporting Matrix in INCD 1	January 1, 2011	January 1, 2012
<u>LEAK</u> <u>0</u>	Added LEAK 2.05 4. - Mechanical Fitting Leak. Was missed when October 1, 2011 revision were issued. LEAK 4: Added Reference 13 - 46 Hawk Manual	October 1, 2011	January 1, 2012
<u>LEAK</u> <u>2.09</u>	<p>1. A.: Added "laser diode based gas detection instrument" as an instrument that can be used for Walking Leak Survey. This is due to the Southern Cross 46 Hawk instrument that is now available.</p> <p>1. D.: Added a list of items that should be sampled when present along the route of the gas main and/or service: man-holes, catch basins, electric and telephone duct openings, and water meter boxes.</p> <p>1. G.: Added "laser diode based gas detection instrument's intake should be as close to ground surface as practical"</p> <p>1. G. (3): Inserted "The instrument's intake probe should be moved slowly from side to side as the surveyor walks along the general location of the gas line."</p> <p>1. H. (1): Inserted "The instrument's intake probe should be moved slowly from side to side as the surveyor walks along the general location of the gas line." When surveying service lines.</p> <p>1. I. (2): Added to surveying regulator stations, farm taps, outside meter sets; "If the instrument is equipped with probe stiffener, the stiffener can be used to extend the probe, if necessary, to sweep over the above ground piping."</p> <p>1. L. (1) (a): Added a statement "If the surveyor is using the Southern Cross 46 Hawk, a CGI is not necessary. The 46 Hawk can be used to classify leak since it will quantify and pinpoint below ground leaks." This is in reference to actions to be taken when the FI or Gas Detection Instrument indicates a possible Class 1 below ground leak.</p> <p>1. M.(1) (a): Revised list of adverse conditions that should be taken into consideration in determining if weather or conditions are suitable for a walking leak survey. Adverse weather conditions include: steady rain, standing water, heavy frost layer, or ice covering the ground surface.</p>	October 1, 2011	January 1, 2012

1. M. (1) (b): Added if the area to be leak surveyed is covered by one or more of the conditions listed in (a), a walking survey should not be performed. Survey could be moved to other areas not experiencing the conditions such as an area covered by a hard surface.

1. M. (1) (c): Added steady wind speeds of approximately 25 mph or greater may result in an inaccurate survey. When continuous, high wind condition exists, surveyor should be moved to an area that is shielded by buildings or geographic features.

1. M. (1) (d): Added when leak surveying over frozen ground, the surveyor should perform the survey in the same manner as if the gas line was under hard surface.

1. M. (2): Added "Snow cover has little effect on gas migration unless there is a frost cap or heavy frost under the snow."

LEAK
4

Added Reference 13 - 46 Hawk Manual

January 1, 2011 January 1, 2012

Correcting a printing error that had Mechanical Fitting Leak Data printed on back of Leak Survey Daily Report

Form 04 - Leak Survey Daily Report Form

Form 05 - Mechanical Fitting Leak Data Form

MAIN
1

3. B.: Added a requirement for recording locations on our electronic gas system maps where minimum cover could not be obtained when installing a gas main and additional protective measures had to be installed.

October 1, 2011 January 1, 2012

8. A.: Deleted the field tile exemption for the 12" clearance with gas transmission lines. The 12" clearance applies to all underground utilities and structures.

8. B.: Clarified the 12" clearance is for both vertical and horizontal directions from high pressure distribution and distribution mains.

8. C.: Inserted an item that provides some options for providing protection to a main if minimum cover cannot be achieved. Options include: installing a shield such as a sleeve, Tuff-N-Buff, rubber matting, fiberglass or PVC shield, or a casing pipe installed around or along the main. Gas Engineering may specify an alternative protection method.

8. F.: Added "steam pipes" as an example of a heat source to protect PE pipe from either by sufficient clearance or insulation.

11. C.: Revised backfill material requirements by increasing the minimum cover over the pipe from 3" to 12" of clean construction material, granular material equal to or less than 1/4" in size, or sand before excavated material containing larger material is placed in the excavation.

11. D.: Added description of acceptable excavated material that can be placed in an excavation after the initial cover is

placed. The excavated material should be free of rocks larger than 2", construction debris, concrete/asphalt chunks, brush, skids, or other material that could damage the pipe or coating.

11. E.: Added "If suitable material is not available to initially cover the pipe, a rock shield such as Tuff-N-Nuff or a rigid sleeve can be installed around the main, may be used in lieu of material listed in "C".

METR 0	<p>Added:</p> <p>METR 2.14 7. Corrosion Control Inspection Follow Up</p> <p>METR 2.19 7. Corrosion Control Inspection Follow Up</p> <p>METR 2.25 - Ultrasonic Meter Testing</p> <p>METR 3.03, METR 3.04 - Updated sizing tables with American 1813C regulator capacities</p> <p>METR 3.07 thru METR 3.14 - Updated by replacing Fisher HSR with American 1813C regulator.</p> <p>METR 4:</p> <p>Updated Form 01 - Electronic Corrector Inspection Form (January 1, 2012)</p> <p>Added:</p> <p>Form 04 - Ultrasonic Gas Flow Meter Inspection Form, Rev 1</p> <p>Added:</p> <p>Reference 02 - American 1813C Tech Bulletin</p> <p>Reference 03 - American 1813C Operating Instruction Manual</p> <p>Reference 04 - American 1813C Repair Parts</p>	Janu- ary 1, 2011	Janu- ary 1, 2012
METR 2.11	<p>5. B. (8): Revised to provide manufacturer specific instructions on replacing diaphragm meter indexes.</p> <p>6. C.: Inserted new item requiring contractor to provide an electronic copy of programming (marriage) and MRB (divorce) files for all meters where applicable.</p> <p>6. H.: Added procedures that will be followed by Ameren Illinois for sample testing meters repaired by contractor.</p>	Janu- ary 1, 2011	Janu- ary 1, 2012
METR 2.16	<p>3. B.: Added that additional copies of the completed Gas Meter Data Sheet should be sent to End User Transportation (EUT) for gas transmission customer and Customer Accounts (CAD) when there are potential billing adjustments.</p> <p>4. C. (1) (c): Changed Corrector Factor to Corrector Information in the Installation Information to match the form.</p>	Octo- ber 1, 2011	Janu- ary 1, 2012
METR 2.19	<p>3. D.: Added three corrosion control inspection items, atmospheric corrosion, disbonded coating, and needs paint when performing pressure factor verification.</p>	April 1, 2010	Janu- ary 1, 2012

UNCONTROLLED IF PRINTED

	7.: Added Corrosion Control Inspection Follow-up procedures and reporting requirements. Items have been added to the spreadsheet used when verifying pressure factors		
METR 2.25	Completely new section for Ultrasonic Meter Testing		January 1, 2012
METR 3.01	1. B.: Added Ameren Illinois Metering as another group to contact for selection of meters larger than 7M175 and delivery pressure greater than 5 psig. 3.: Added a note (4) to the American AC 250 that an alternate meter option is the Sensus R275 AccuWave.	January 1, 2011	January 1, 2012
METR 3.02	1. B.: Added Ameren Illinois Metering as another group to contact for selection of meters larger than 7M175 and delivery pressure greater than 5 psig. 3.: Table: Added the Rockwell R275 meter to the meter capacity table.	January 1, 2011	January 1, 2012
METR 3.03	Updated Regulator Sizing capacities for 7" w.c. Delivery Pressure. Replaced American 1813C for Fisher HSR and removed Fisher S303 no longer available	January 1, 2011	January 1, 2012
METR 3.04	Updated Regulator Sizing capacities for 2 psig Delivery Pressure. Replaced American 1813C for Fisher HSR	January 1, 2011	January 1, 2012
METR 3.06	Updated by removing American 1813C from the Alternate Approved list.	January 1, 2011	January 1, 2012
METR 3.07	Updated Standard with American 1813C regulators	April 1, 2010	January 1, 2012
METR 3.08	Updated Standard with American 1813C regulators	April 1, 2010	January 1, 2012
METR 3.09	Updated Standard with American 1813C regulators	April 1, 2010	January 1, 2012
METR 3.10	Updated Standard with American 1813C regulators	April 1, 2010	January 1, 2012
METR 3.11	Updated Standard with American 1813C regulators	April 1, 2010	January 1, 2012

UNCONTROLLED IF PRINTED

METR 3.12	Updated Standard with American 1813C regulators	April 1, 2010	Janu- ary 1, 2012
METR 3.13	Updated Standard with American 1813C regulators	April 1, 2010	Janu- ary 1, 2012
METR 3.14	Updated Standard with American 1813C regulators	April 1, 2010	Janu- ary 1, 2012
METR 4	Updated Form 01 - Electronic Corrector Inspection Form (January 01, 2012) By adding corrosion inspection items, pressure valve - found and as left position, CAD notification, and Supervisor review Added the following: Form 04 - Ultrasonic Gas Flow Meter Inspection Form, Rev 1 Reference 02 - American 1813C Tech Bulletin Reference 03 - American 1813C Operating Instructions Manual Reference 04 - American 1813C Repair Parts	Janu- ary 1, 2011	Janu- ary 1, 2012
ODOR 2.03	3. H.: Added "readily detectable" to clarify which odorant intensity reading has acceptable range of 0.1% up to 0.8% gas in air.	Janu- ary 1, 2011	Janu- ary 1, 2012
OQAL 0	Revised title of OQAL 1 13. To OQ Review Added OQAL 4 - Forms and Reference Materials Added Form 01 - Ameren Illinois Contractor Hiring Checklist	Janu- ary 1, 2011	Janu- ary 1, 2012
OQAL 1	12. D.: Added new section: Hiring Requirements for Contractors Qualified Under the Ameren OQ Plan. Provides requirements for hiring contractors who have to be qualified under Ameren's OQ Plan since the contractor either does not have an OQ Plan or has not been OQ'd by a third party.	Janu- ary 1, 2011	Janu- ary 1, 2012
OQAL 4	New section that contains: Form 01 - Ameren Illinois Contractor Hiring Checklist		Janu- ary 1, 2012
PMRK 1	2.: This section has been revised to better clarify what locations within Class 1/Class 2 versus Class 3/Class 4 locations should be identified with pipeline markers/signs	Octo- ber 1, 2011	Janu- ary 1, 2012

PMRK 3.04	1. B.: Deleted statement that signs are made of polyethylene material.	October 1, 2011	January 1, 2012
POLY 3.02	2.: Corrected Stock Number for Central Plastic 3"IPS x 2"IPS HVTT 5.: Corrected Stock Number for Central Plastic 1" IPS End Cap	October 1, 2011	January 1, 2012
PRES 4	Reprint of Form 1 - Operational Checklist to correct bullet point symbols	January 1, 2011	January 1, 2011
PTRL 2.01	3. A. & C.: Inserted "Exposed transmission pipeline segment(s)" to list of items to be on look-out for and document during patrol. Deleted reference to "previously reported". 3. E.: Deleted since it referred to "critical area" patrol which now only applies to distribution mains. 4. A.: Revised Processing Data: Gas Supervisor will notify both Gas Operations and Services - Pipeline Integrity group and Gas Engineering if patrol indicates a possible change in class location or HCA, exposed transmission line, or any deficiencies that might affect serviceability of the transmission main.	October 1, 2011	January 1, 2012
PTRL 2.02	1.: Deleted reference to transmission mains from critical area patrol. Critical area patrol only applies to distribution mains. 2. E.: Added a new critical area for distribution mains located within 100 feet of blasting operation 3. A. & B.: Deleted reference to transmission mains. 4. (2): Deleted since it had reference to PTRL 2.01 Transmission Patrols 6. B.: Deleted reference to transmission mains.	October 1, 2011	January 1, 2012
PTST 1	1. C.: Inserted a new item: All nondestructive testing and/or repairs shall be completed before a pipeline segment is subjected to any leak or strength testing. Final tie-in welds will be non-destructive tested as required prior to pressurizing of the pipeline segment. 1. D.: Inserted a new item to clarify that by-pass installed utilizing fittings on existing pipe and steel or PE pipe shall be pressure tested in the same manner as new pipeline segment. This does not apply to by-pass connected between tapping and stopping equipment which would be checked for leaks at the operating pressure. 3. C.: Revised the language for pressure testing mains with MAOP less than 30% SMYS and at or above 100 psig. Pressure testing these mains can be performed in a couple of manners: 1) a single combination leak/strength test at 1.5 times the MAOP or 2) leak test at a minimum of 100 psig	October 1, 2011	January 1, 2012

UNCONTROLLED IF PRINTED

for 1 hour or the duration specified in PTST 2.01 followed by a strength test at 1.5 times the MAOP for a minimum of 1 hour.

3. D.: Deleted

3. E. Table: Corrected Yield Strength on Grade B pipe to 35,000 PSI and changed PSIG to PSI on X-42 and X-52 pipe

6. A.: Revised language for testing components attached to existing pipeline require testing at pressure of 1.5 times the planned MAOP with a minimum duration of 10 minutes or the minimum duration shown in PTST for the size of fitting being used.

6. B.: Added for components installed on systems with MAOP over 100 psig, Gas Operations and Services - Engineering or Gas Engineering will specify not only the test pressure but also the minimum test duration.

PURG 2.01	8. A.: Revised to limit use of vacuum purge/air mover to only distribution pressure systems and on pipes with nominal diameter of 6" and smaller	October 1, 2011	January 1, 2012
QUAL 0	Forms and Reference Materials: Added Form 17 - Steel Welding	January 1, 2011	January 1, 2012
QUAL 4	All of the Quality Assurance forms have been updated with additional items to be checked during inspections. Added Form 17 - Steel Welding	January 1, 2011	January 1, 2012
REGS 2.01	1. G.: Inserted a new item that addresses Gas Control involvement in Operational Inspections on regulator stations equipped with SCADA equipment and/or electronic pressure recorder. Individual performing operational inspection should contact Gas Control prior to and after completion of inspection. Any changes in alarm settings must be submitted to Gas Control by the Gas Operations and Services - Technical Services Supervisor.	October 1, 2012	January 1, 2012
REPR 0	Inserted: REPR 2.01 4. Compression Joints on Steel Tees and Valves Added: WELD 3.05 - Welded Strapping For Compression Joints	January 1, 2011	January 1, 2012
REPR 1	3. B. (2): Added "Tapered screw plug is an approved repair method for small, non-corrosion leaks in steel main operating at 60 psig or less. There was not room in the table below to list tapered screw plug. Refer to REPR 1 4. D."	October 1, 2011	January 1, 2012
REPR 2.01	1. D.: Added these procedures outline approved methods for repairing leaking compression couplings on both mains and services and compression joints on tees and valves installed	January 1, 2011	January 1, 2012

UNCONTROLLED IF PRINTED

on mains. Procedures include strapping joints where pull out is detected and leak is eliminated.

4.: Inserted new section on Compression Joints on Steel Tees and Valves. Section outlines procedures for repairing leaking compression joints.

6. E.: Added a records requirement to record location of repaired compression couplings that have not been encapsulated.

6. F.: Added a records requirement to record location of strapped compression joint tees and valves

REPR 2.02	Corrected "effective date" on page 2 that was missed when initially issued.	January 1, 2011	January 1, 2011
REPR 3.05	Added a new Standard Design section on Welded Strapping For Compression Joints.		January 1, 2012
SAFT 1	Corrected "effective date" on document from October 1 2010 to October 1 2011	June 1, 2010	October 1, 2011
SERV 1	<p>2. Section on Depth has been significantly rewritten to include more detailed available options if minimum depth of 18" cannot be achieved.</p> <p>2. B.: Added that specify available options to include: relocation of service to different location, insertion in a metallic pipe, install concrete pad above service line, or other engineering designed means of protection. Location where minimum depth cannot be achieved and protective measures are utilized should be recorded on Gas Service Transaction Card/Sheet.</p> <p>2. C.: Formerly 2. A. which stated service lines shall be installed at a depth which will protect them for excessive external loading and local activities. Expanded the list of activities to now include loaded truck traffic and material storage in addition to the existing language of gardening and farming operations.</p> <p>3. A.: Added "sand" in addition to "well-compacted soil" as a means of providing proper support of service line.</p> <p>3. B.: Added "screened" to the ¼" or less size granular material used to support pipe installed in or across a previously excavated area or unstable soil.</p> <p>3. C.: Added to specify a minimum layer approximately 6" thick of clean construction material, granular material ¼" or less in size, or sand should be placed over the service line before excavated material containing rock, gravel, or cinders is placed in the excavation.</p>	October 1, 2011	January 1, 2012

3. D.: Added to specify excavated material used for backfill must be free of rock larger than 2", construction debris, concrete/asphalt chunks, brush, skids, or other debris that could damage the pipe or its coating.

3. E.: Added options for protecting the pipe if suitable material is not available to cover the pipe. Available options are: rock shield such as Tuff-N-Nuff, or rigid sleeve. Gas engineering may specify other means or material.

4. A.: Clarified that the clearance between the gas service line and buried electric lines or steam pipes is 12" in both the vertical and horizontal direction.

4. A. (1): Added to provide means to shield or sleeve the pipe if the 12" clearance cannot be achieved.

4. A. (2): Added to require recording on Gas Service Transaction Card/Sheet there is reduced clearance between the buried electric or steam line.

4. B.: Added that minimum clearance between service line and other buried utilities, water, sewer, telephone, or CATV is 6".

5. C. (1): Expanded locations to avoid in setting a gas meter to include within 12" of a vent or air intake in addition to the first floor window.

5. C. (2): Added "AC unit" to the list of potential ignition sources that require the meter sets to be more than 3 feet away.

5. E.: Expanding language regarding protecting plastic service lines from shearing action or backfill settlement. The service lines shall be protected by compacting sand or soil backfill under, around, and over the service line connection to main, farm tap, or service riser. Protective sleeve shall be installed over the service line connection to service tee. See Standard Designs in SERV 3 section.

6. F.: Replaced "consideration should be given to installing property line valve on 2" and larger service line" with "A property line valve should be installed on all service lines 2" and larger, where possible.

SERV
2.02

1. B.: Revised service lines in which EFV's are to be installed.

1. B. (1): Individual or branch residential service lines with up to a combined 4 individual meters.

1. B. (2): Individual commercial customer service line with total connected load of 1000 CFH or less.

1. B. (3): Inlet pressure, maximum flow, service size and length are compatible with the EFV sizing tables.

1. D.(1) & (2): Added what constitutes a Replaced Service.

1. D. (1): Replacement of service tee and service line from the gas main to or through the service riser.

January 1,
2011

January 1,
2012

- 1. D. (2): Replacement of the service line from the existing tee to or through the service riser.
- 2. C.: Added "commercial farm taps for single customer with total connected load of 1000 CFH or less" where a steel EFV is installed on outlet of the high pressure distribution service tee and another EFV on the outlet riser of the farm tap for distribution service.
- 3. D.: Expanded tables to include the 2 approved manufactures of PE EFV's, UMAC and Perfection.
- 3. E.: Expanded tables to include the 2 approved manufacturers of the steel EFV's. UMAC and Perfection.

STLP 0	Inserted: STLP 1 2: General.	October 1, 2011	January 1, 2012
STLP 1	<p>1.: Moved original B. and C. to new section 2.</p> <p>2.: Inserted a new section "General" that includes references to construction requirements in MAIN 1 and SERV 1 along with reference to STLP 2.01 for steel pipe stock codes.</p> <p>2. A.: Added new item to address marking of steel pipe. "Steel pipe, coated or bare, shall have indelible ink identification markings or stamping that clearly identifies the pipe specifications. If the identification markings have faded or are no longer readable the steel pipe shall not be installed."</p>	January 1, 2011	January 1, 2012
STLP 2.01	5.: In Note at bottom of Stock Code table added "Yield strength shown in table is minimum strength. Multi-stenciled pipe will indicate a range of yield strengths. Pipe shall be inspected prior to use to ensure it meets yield strength requirements for its planned MAOP."	January 1, 2011	January 1, 2012
TAPS 2.04	1.: Corrected by replacing "Mueller" with "T. D. Williamson"	January 1, 2011	January 1, 2012
VALV 2.02	<p>1. B.: Inserted "Communication with Gas Control, prior to and after, when any inspection and/or maintenance work is scheduled to be performed on any valve that is monitored through the SCADA system and/or operated by Gas Control."</p> <p>3. C.: Following maintenance of a valve monitored by Gas Control verify with Gas Control that valve operation has returned to normal.</p>	October 1, 2011	January 1, 2012
WELD	The Welding Section has been changed completely. All of the January 1, 2011 sections have been deleted and replaced with completely new procedures.	January 1, 2011	January 1, 2012

WELD 0	Totally new Table of Contents	January 1, 2011	January 1, 2012
WELD 1	Revised significantly with too many changes to list	January 1, 2011	January 1, 2012
WELD 2.01	New section: Safe Welding Practices		January 1, 2012
WELD 2.02	New section: Welder Performance Qualifications		January 1, 2012
WELD 2.03	New section: Construction of Pipelines and Pipe Systems		January 1, 2012
WELD 2.04	New section: Maintenance Welding		January 1, 2012
WELD 2.05	New section: Visual Inspection		January 1, 2012
WELD 2.06	New section: Radiographic Examination		January 1, 2012
WELD 2.07	New section: Magnetic Particle Inspection		January 1, 2012
WELD 2.08	New section: Liquid Penetrant Inspection		January 1, 2012
WELD 2.09	New section: Ultrasonic Wall Thickness Examination		January 1, 2012
WELD 2.10	New section: Arc Burn Removal		January 1, 2012
WELD 3.01	New Standard: Post - Heat Treatment		January 1, 2012

WELD 3.02	New Standard: Useful Welding Information	January 1, 2012
WELD 4	New forms: Form 01 - Ultrasonic Thickness Record Form 02 - Daily Radiographic Report Form 03 - Ameren Welder Certification Card Reference Material: All of the Qualifying Welding Procedures are now contained in the Reference Materials section. These were originally WELD 2.04 through WELD 2.49 in the January 1, 2011 O&M. Qualifying procedures have been updated through review by EN Engineering.	January 1, 2012
WELD	Delete the following: WELD 2.01 - Welder Qualifications WELD 2.02 - Production Welding WELD 2.03 Inspection and Repair of Production Welds WELD 2.04 thru Weld 2.49 - WPQR's which are now in Reference Materials section.	January 1, 2011

Supersedes: October 1, 2011