

09-41857

0198100008  
LP town Gas  
Champaign  
SR/tech



July 8, 2009

Mr. Greg Dunn  
Illinois EPA  
1021 North Grand Avenue East  
Springfield, Illinois 62794-9276

**SUBJECT: Addendum to On-Site Remedial Action Plan  
AmerenIP Former MGP Site  
Champaign, Illinois**

Dear Mr. Dunn:

On behalf of AmerenIP, PSC Industrial Outsourcing, LP (PSC) is submitting the attached addendum to the On-Site *Remedial Action Plan* for the former manufactured gas plant site in Champaign, Illinois. The addendum presents finalized details regarding the proposed ISCO treatment as requested by the IEPA in their approval letter dated December 22, 2008. A pilot study will be conducted in July 2009 to determine the feasibility of the ISCO approach prior to implementing it on the remediation site. Upon receiving sufficient data from the pilot study and approval from the IEPA, ISCO will be used to treat deep impacted soil on site.

If you have any questions or require additional details, please contact me by phone at (618) 281-1575 or e-mail me at [psazama@pscnow.com](mailto:psazama@pscnow.com).

Sincerely,

**PSC Industrial Outsourcing, LP**  
Peter T. Sazama, PG  
Senior Project Manager

ORIGINAL

RECEIVED

JUL 09 2009

IEPA/BOL

RELEASABLE

JUL 09 2009

REVIEWER MD

## 1.0 ISCO PILOT TEST

A pilot test will be conducted to determine the feasibility of treating site contaminants with an in-situ chemical oxidation (ISCO) approach. The ISCO technology selected for the test is alkaline activated persulfate (AAP). This method involves activation of the sodium persulfate oxidant ( $\text{Na}_2\text{S}_2\text{O}_8$ ) by adjusting the pH of the aquifer to alkaline conditions (typically greater than pH of 10.5). The activation of persulfate in this manner results in the formation of oxidant species (including sulfate radicals [ $\text{SO}_4^{\cdot-}$ ]), which are capable of destroying the target contaminants in-situ.

The proposed target area encompasses approximately 900 square feet in the vicinity of borings B-501, B-502, and UTB-27. Treatment will be conducted at depths of 10 to 25 feet below surface grade (bsg) depth interval.

The mass of oxidant to be injected in the pilot test area was designed based on an assumed contaminant mass of up to 2,000 pounds (LBs).

### 1.1 OXIDANT BATCHING PROCESS

The sodium persulfate oxidant will be delivered to the site in a dry granular form, which will be diluted with water into a concentrated oxidant batch. Approximately 20,000 LBs of sodium persulfate oxidant (FMC Klotzur) will be prepared for injection.

The concentrated oxidant solution will then be blended together with sodium hydroxide (NaOH, delivered to the site as 50% solution in 55-gallon drums). Approximately 13,000 LBs of NaOH will be used to adjust the shallow/perched aquifer pH to the required alkaline activation range.

The final injection solution volume will be approximately 13,000 gallons, containing 190 g/L sodium persulfate, and 120 g/L of NaOH.

The oxidant batching system consists of the following major equipment:

- Bag dump station and feed system for batching dry chemical.
- 1,100 gallon cone bottom tank with integrated tank/mixer stand.
- Tank mounted industrial grade mixer.
- NaOH pump and mixing system.
- Secondary containment unit.

RELEASABLE

JUL 09 2009

REVIEWER MD

Refer to **Figure 1** for a process and instrumentation diagram (P&ID) of the batching equipment.

## 1.2 ISCO INJECTION

As discussed in the previous section, a total of up to 20,000 LBs of sodium persulfate, along with 13,000 LBs of NaOH will be injected.

The oxidant will be injected at 18 injection well locations. Depending upon the treatment interval, the volume injected into each location will be approximately 720 gallons of solution. The oxidant injection rate was assumed to be approximately 1 to 2 gpm per well depending on the hydraulic conductivity of the area surrounding the injection wells.

The oxidant injection system consists of the following major equipment:

- Chemically compatible dual-diaphragm injection pump.
- Distribution manifold piping system designed to connect up to ten injection wells at a time. The manifold system includes flow meters, pressure gauges, and sample ports for monitoring the injection process.
- 1,500-gallon polyethylene tank for the injection solution.
- Secondary containment unit.

Refer to **Figure 1** for the P&ID of the injection equipment.

## 1.3 ISCO PROCESS MONITORING

During the ISCO injections, the following parameters will be monitored:

- Total oxidant/reagent volumes injected per well,
- Injection flow rates and wellhead pressures,
- Water levels at available observation wells (if any available),
- Concentrations of oxidant/reagents (field kit methods, e.g., persulfate using a CHEMetrics CHEMets® Kit), and
- Periodic field water quality parameters (ORP, pH, dissolved oxygen (DO), temperature, and conductivity) at selected wells, and in-situ oxidant concentrations. This will be conducted on an as-needed basis to evaluate oxidant distribution in the subsurface.

## 1.4 ISCO IN-SITU SOIL MIXING

In-situ soil mixing will be performed on the excavation floor soils. The intent of the ISCO soil mixing is to expedite the oxidant treatment reaction on the excavation floor. The chemical oxidant will be placed in the bottom of the excavation prior to backfilling using a low flow diaphragm pump and mixed into the bottom soil to aid in contaminant mass reduction. The

chemical oxidant will be applied at a rate no greater than 1/2-gallon per square foot. The mixing of the oxidant and soil will be performed using the excavator.

## **1.5 SOIL SAMPLING**

Post-injection monitoring will be conducted approximately four weeks after the pilot test application. Since the monitoring will be done beneath the tent structure, the timeline for monitoring will be determined when the first excavation phase is completed and the tent is moved to the phase II location. The monitoring will consist of excavating the perimeter of the pilot study area to a depth of approximately 25 feet. The monitoring will use both visual and analytical analyses to verify how the treatment has worked.

Soil samples will be collected at depths of 10 to 15 feet bgs and 20 to 25 feet bgs.

## **1.6 GROUNDWATER SAMPLING**

A baseline groundwater sampling event and three post-ISCO performance monitoring events will be conducted as part of the pilot test. Post-injection monitoring will be conducted at approximately 1, 2, and 3 to 4 weeks following the pilot test application.



Groundwater samples will be collected from selected ISCO injection wells to assess the oxidant concentration and pH trends before and after the pilot injection. Sampling will be conducted using standard low-flow sampling techniques using a YSI 600 XL (or similar) water quality meter equipped with a flow-through cell. Measurements will consist of the following parameters:

- ORP,
- pH,
- Temperature,
- Conductivity,
- DO, and
- Depth to water.

In addition, field analyses for sodium persulfate concentrations using a CHEMetrics CHEMets® Kit will be performed.

The level of contaminant destruction within the pilot test area will be evaluated at a later date (minimum of 3 to 4 weeks) by collecting groundwater samples from the treated soil intervals.

**LEGEND**

- SP -- SAMPLE PORT
- P -- PRESSURE GAUGE
- FM -- FLOW METER/TOTALIZER
- DD -- DRY DISCONNECT
- SM -- STATIC MIXER
- PR -- PRESSURE RELIEF VALVE
- FT -- FLOW TOTALIZER
- T -- TEMPERATURE GAUGE
-  -- BALL VALVE
-  -- CHECK VALVE

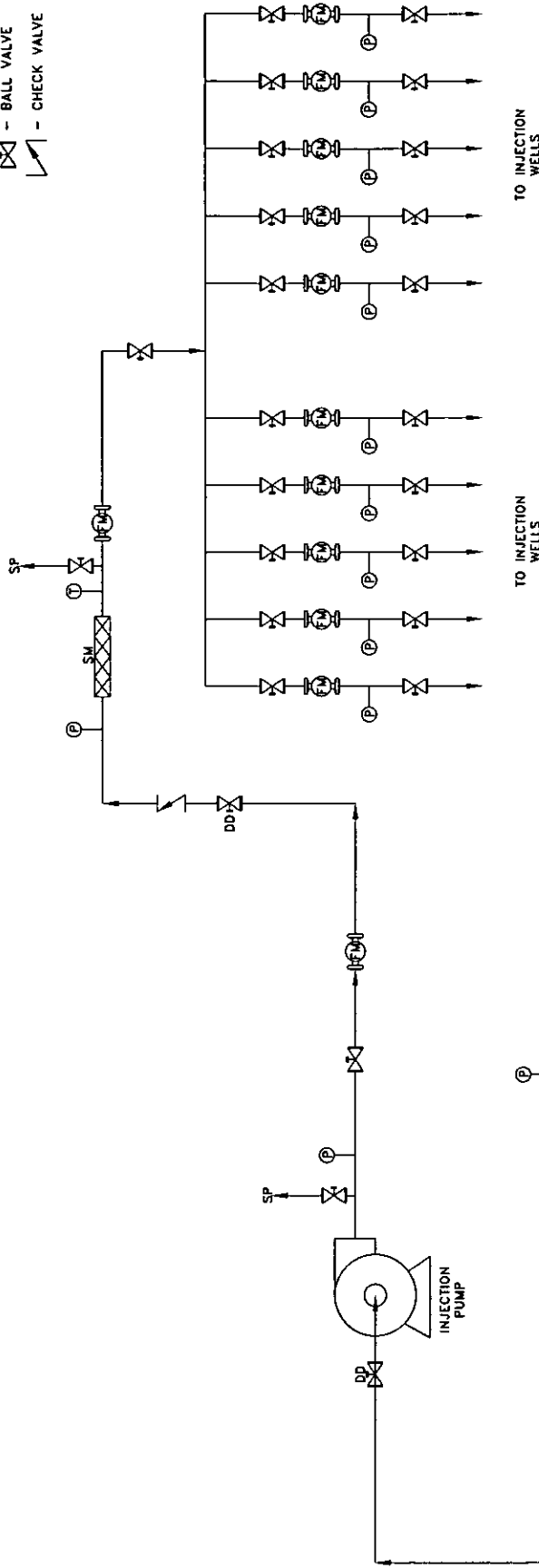



**XDD**  
STRATEGIC ENVIRONMENTAL SOLUTIONS

**TITLE: P&ID PUMP AND MANIFOLD**  
**SKID LAYOUT**  
 CHAMPAIGN MGP FACILITY  
 CHAMPAIGN, ILLINOIS

DRAWN BY: DKR  
 CHECKER BY: SC  
 PROJ. MGMT. APPROVAL: SC

SCALE: NOT TO SCALE	DATE: JUNE 19, 2009
PROJECT NO.: 09003	CLIENT: PSC
DRAWN BY: DKR	CHECKER BY: SC
PROJ. MGMT. APPROVAL: SC	

FIGURE 1

3

REV: